



samtec

THE
CATALOG
2021

A DIFFERENT BREED OF CAT

INNOVATIVE TECHNOLOGIES • SUDDEN SERVICE®

Founded in 1976, Samtec is much more than just another connector company. We put people first, along with a commitment to **exceptional service**, **quality products** and **innovative technologies** that take the industry further faster. This is enabled by our unique, **fully integrated business model**, which allows for true **collaboration and innovation** without the limits of traditional business models.

We believe that taking care of our customers and our employees is paramount in how we approach our business, and this belief is deeply ingrained throughout Samtec worldwide.

INNOVATIVE TECHNOLOGIES

From standard cataloged products to unique high-performance design, Samtec's **SOLUTION BLOCKS** are designed to support any interconnectivity need, regardless of application, performance requirements or environment.

Silicon-to-Silicon



HIGH-SPEED BOARD-TO-BOARD

HIGH-SPEED CABLE

OPTICS

RF

Core Board-to-Board



MICRO/RUGGED

FLEXIBLE STACKING

SUDDEN SERVICE®

Samtec is the service leader in the industry, offering unmatched technical support, free product samples and access to online resources, and innovative online tools to help streamline the design process.



HIGH-SPEED BOARD-TO-BOARD

OPEN-PIN-FIELD ARRAYS | GROUND PLANE STRIPS | EDGE CARDS | ULTRA-MICRO | BACKPLANE

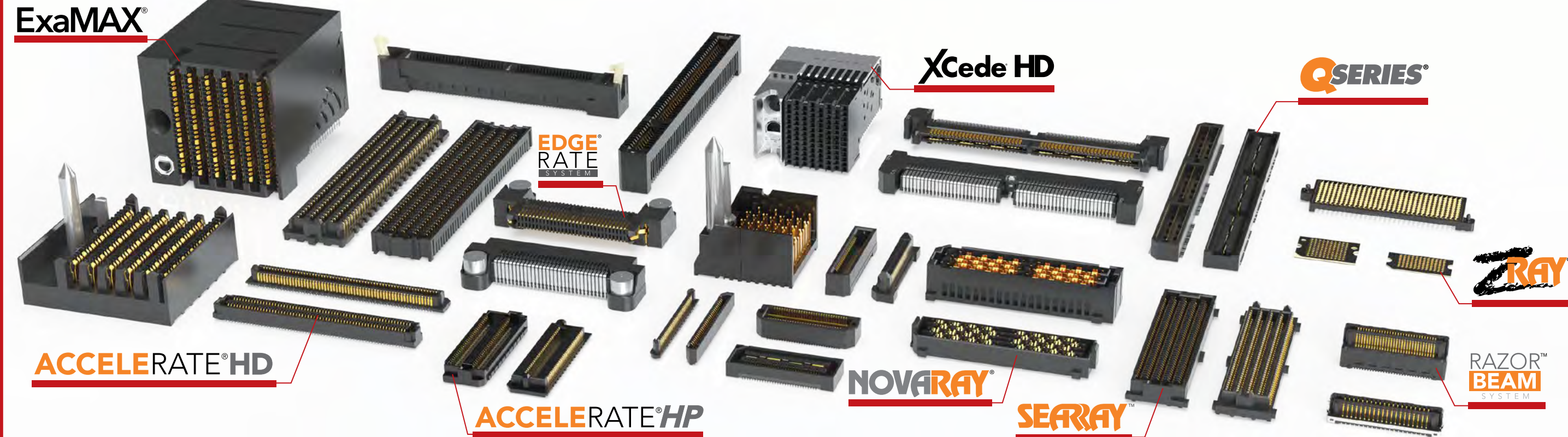

HIGH-SPEED CABLES

FLYOVER[®] | MID-BOARD & PANEL | BACKPLANE | MICRO COAX & TWINAX

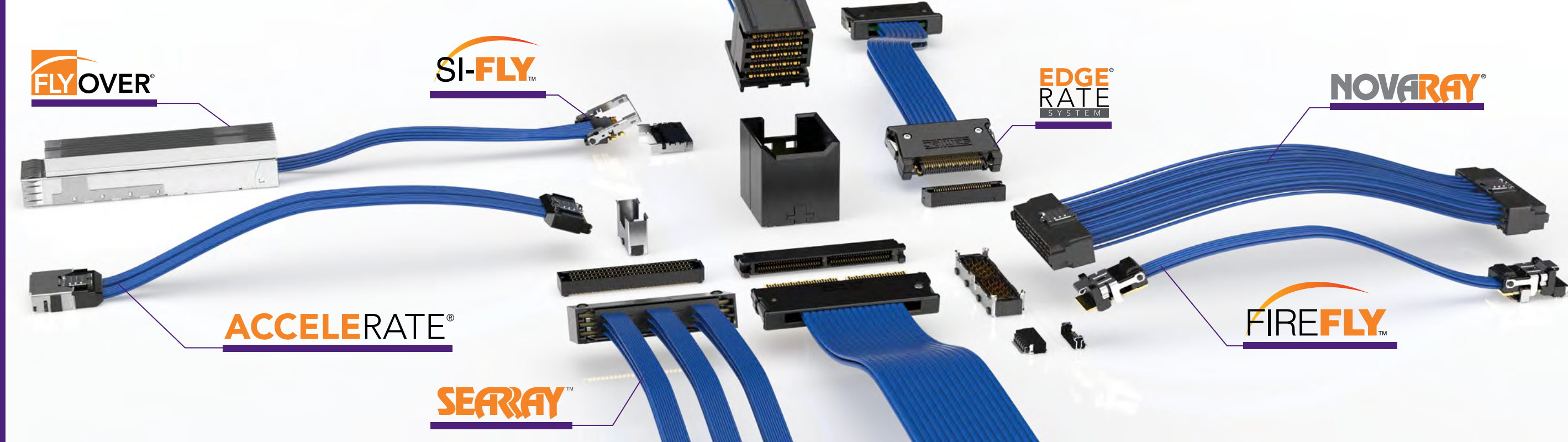

MICRO/RUGGED

RUGGED MICRO SYSTEMS | BLADE POWER | MICRO DISCRETE WIRE | MICRO SEALED I/O

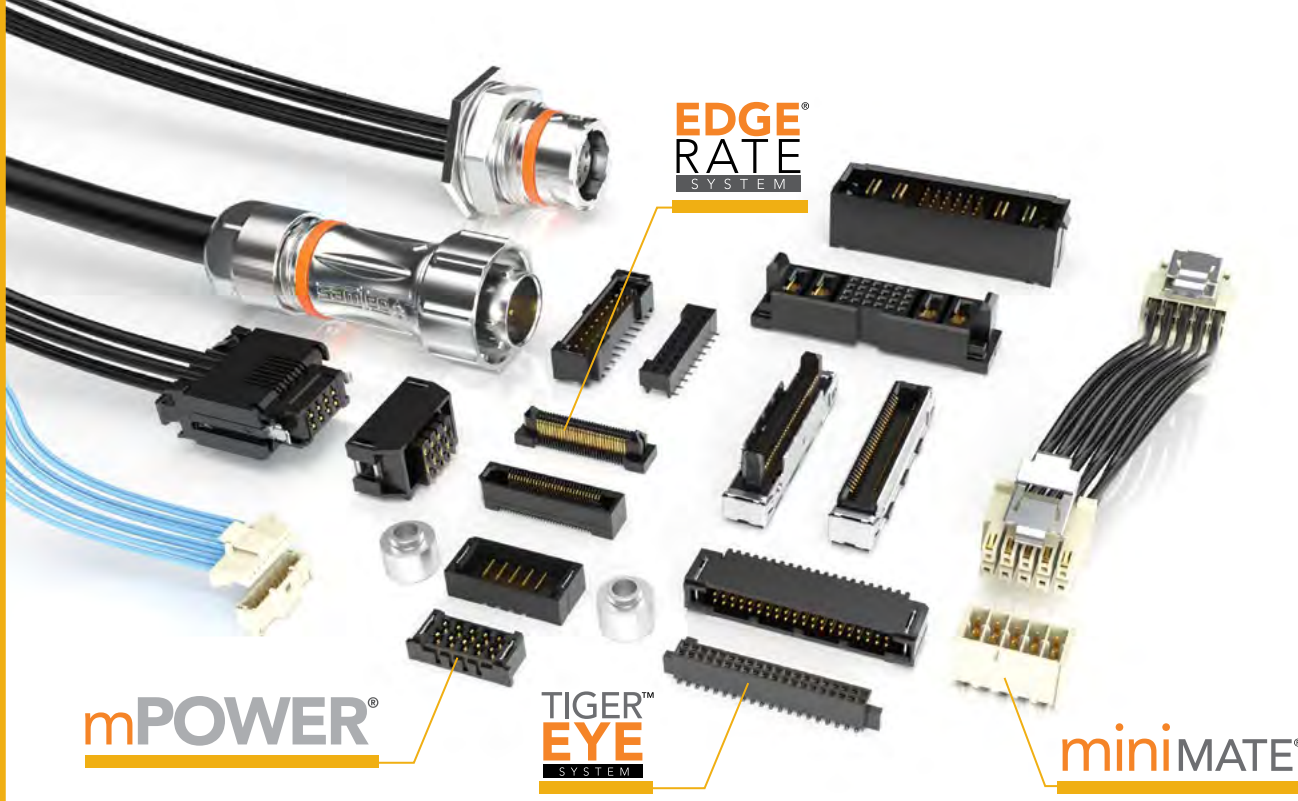

FLEXIBLE STACKING

LOW PROFILE | PASS-THROUGH | ONE-PIECE | SKYSCRAPERS | SHROUDED HEADERS | IDC SYSTEMS

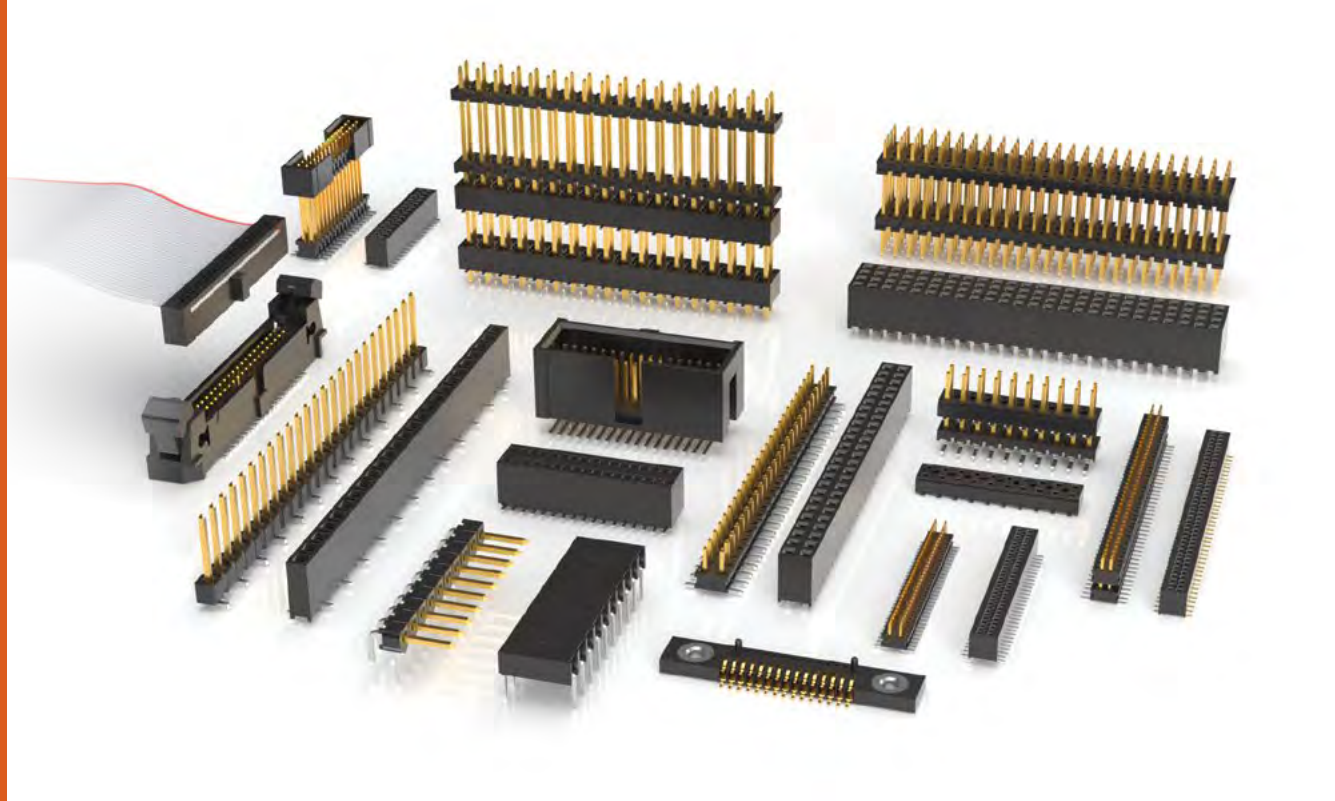

OPTICS

MICRO FLYOVER SYSTEM[™] | EXTENDED TEMP | PCI EXPRESS[®]-OVER-FIBER



RF

PRECISION RF | 50 Ω SOLUTIONS | 75 Ω SOLUTIONS | ORIGINAL SOLUTIONS



QUICK REFERENCE

Company, Product & Service Overview	2-7
Integration Leads to Innovation	8-9
Sudden Service®	10-11
Online Tools	12-13
Express Modifications & Engineered Customs	14
Rugged Features & Options	228
Industry Standards	308-309

HIGH-SPEED BOARD-TO-BOARD

High-Speed/High-Density Arrays

NovaRay® Extreme Density/Speed Arrays	16-17
AcceleRate® HP High-Performance Arrays	18-19
AcceleRate® HD Slim Body Arrays	20-21
SEARAY™ High-Density Arrays	22-25
SEARAY™ 0.80 mm Pitch Arrays	26-27
LP Array™ Low-Profile Arrays	28-29

High-Speed Compression Interposers

Z-Ray® Ultra-Low Profile Compression Interposers	32-35
Low-Profile Compression Interposers	36

High-Speed Mezzanine

Q Strip® Ground Plane Strips	38-41
Q2™ & Q Rate® Ground Plane Strips	42-44
High-Speed Signal & Power Combinations	45
Q Series® Right-Angle & Edge Mount Strips	46-47
Edge Rate® Contact Strips	48-54

Ultra Micro Interconnects

Razor Beam™ Hermaphroditic Strips	56-58
Micro Blade & Beam Strips	59-61

High-Speed Edge Card Connectors

0.60, 0.80 & 1.00 mm Pitch Edge Rate® Edge Cards	64-71
Micro & Mini Edge Cards	72-79
PCI Express® Edge Cards	80-83

High-Speed Backplane

ExaMAX® High-Speed Backplane	86-89
ExaMAX® Backplane Flyover® Cable Systems	90-91
XCede® HD High-Density Backplane	92-94

HIGH-SPEED CABLE

High-Speed Cables

Flyover® Technology	96
Micro Coax & Twinax Cable Specifications	97
Flyover® QSFP Cable Systems	98-101
NovaRay® Extreme Speed/Density Flyover®	102-103
AcceleRate® Slim Flyover® System	104-105
Si-Fly™ Low-Profile Cable System	106-107
FireFly™ Copper Micro Flyover System™	108-110
Micro Edge Card Flyover® Systems	111-112
Micro Coax & Twinax Cables	113-121

High-Speed I/O

Eye Speed® HD & Eye Speed® I/O Systems	122-123
MSA Transceiver Interfaces & Cages (SFP+)	124
Universal Serial Bus (USB) Interfaces	125-126

Evaluation & Development Kits	310-311
Testing (SET, ELP, DQT)	312-313
High-Speed Channel Performance Metric	316
General Specifications	317
Index by Brand	318
RF Product Index	319
Index by Series	320-321

OPTICS

Optical Systems

FireFly™ Optical Micro Flyover System™	128-132
Optical Patch Cable & Adaptor	133
Optical Evaluation & Development Kits	134

PRECISION RF

RF Systems

50 Ω Precision RF (18 GHz to 110 GHz)	138-151
Bulls Eye® Test Point Systems	152-154
50 Ω and 75 Ω Solutions (3 GHz to 12 GHz)	156-168
Original RF Solutions	169
Custom RF Solutions	170

MICRO/RUGGED

Tiger Eye™/Rugged

1.00 mm Pitch Micro Mate™ Systems	172-177
0.80 mm Pitch Tiger Eye™ Systems	178-181
.050" Pitch Tiger Eye™ Systems	182-189
2.00 mm Pitch Tiger Eye™ Systems	190-194

Power & Sealed I/O

mPOWER® Ultra Micro Power Systems	196-199
PowerStrip™/20/30/40 Systems	200-207
EXTreme Ten60Power™ & LPHPower™	208-211
Mini Mate® & Power Mate® Systems	212-217
Power Headers & Sockets	218-219
Bayonet Circular AccliMate™ IP68 Systems	220-223
Mini Push-Pull AccliMate™ IP67 Systems	224
Threaded Circular AccliMate™ IP68 Systems	225
Rectangular AccliMate™ IP68 Systems	226-227

FLEXIBLE STACKING

Board Stacking

Flexible Stacking	230-233
One-Piece Interfaces	234-235
0.50 mm, 0.635 mm, 0.80 mm Pitch Blade & Beam	236-241
0.80 mm & 1.00 mm Pitch Pin & Socket	242-246
.050" Pitch Strips	247-258
2.00 mm Pitch Headers & Stackers	259-266
2.00 mm Pitch Sockets & PC/104-Plus™	267-272
.025" (0.64 mm) SQ Post Headers, Stackers	273-283
.025" (0.64 mm) SQ Post Sockets & PC/104™	284-291

IDC/Flat Cable Systems

FFC Jumpers & Interfaces	294-295
.100" Pitch IDC Systems	296-299
2.00 mm Pitch Tiger Eye™ IDC Systems	300-303
.050" Pitch Tiger Eye™ IDC Systems	304-307

INTEGRATION LEADS TO

Samtec's integrated approach provides high-level design and development of advanced interconnect systems and **TECHNOLOGIES**, along with industry-leading expertise that allows us to offer effective strategies and support for **optimizing the entire signal channel of high-performance systems.**



INNOVATION

Samtec is structured like no other company in the interconnect industry. We work in a fully integrated capacity that enables true collaboration and results in uniquely innovative **PRODUCTS** because **our technology teams are not limited by the boundaries of traditional business units.**

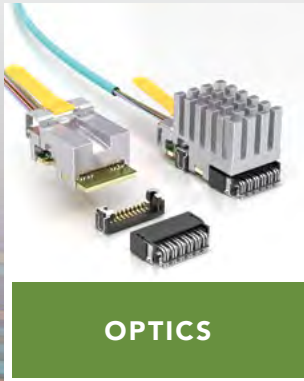

OPTICS



HIGH-SPEED CABLES



PRECISION RF



HIGH-SPEED / HIGH-DENSITY
BOARD-TO-BOARD



MICRO RUGGED / POWER

SUDDEN SERVICE®

Samtec's Sudden Service® provides unmatched global service, free access to data and industry leading tools, along with engineering support, to help you design, develop, test and deliver the best solution for any complex application.

GLOBAL OPERATIONS & SUPPORT NETWORK



MANUFACTURING
7 Global Manufacturing Locations



SUPPORT CENTERS
11 Global Support Locations



SALES LOCATIONS
125+ Regional Sales Representatives

AWARD-WINNING SERVICE

#1 in Bishop's Customer Survey of the Electronic Connector Industry.



Samtec has been consistently rated as the #1 connector company in North America, Europe and Asia. This is the highest overall rating in the Bishop & Associates' U.S., Europe and Asia Customer Surveys of the Electronic Connector Industry.

UNMATCHED LEAD-TIMES

Innovative Programs & Systems Enable Deliveries in Days, Not Weeks.

Reserve™

SHIPS TOMORROW



This new designation allows customers to **quickly and easily identify availability of over 200,000 of Samtec's most popular connectors and cables - guaranteed to ship in 1-day.**

Look for the **Reserve** badge throughout samtec.com to quickly determine if your part number is eligible, along with current availability, quantity breaks and pricing. Hundreds of part numbers are being added daily!

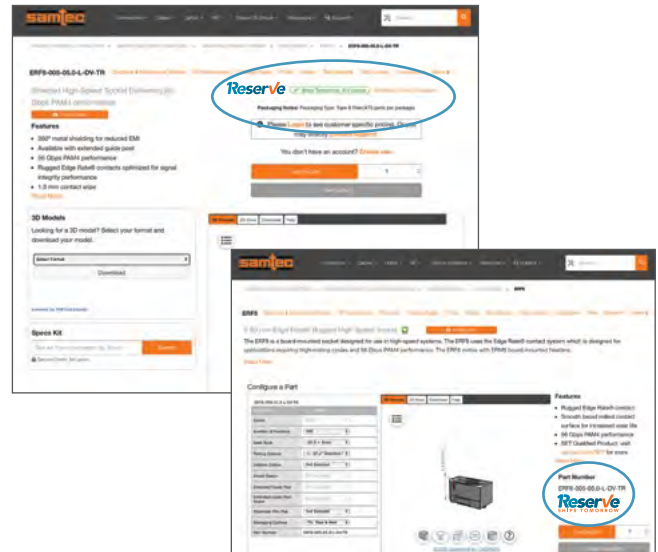

Free product samples, shipped in 24-hours or less have been a cornerstone of Samtec Sudden Service® since the company was founded. Visit samtec.com to quickly request your sample.

An innovative shipping program that **bridges the gap between manufacturing facilities and customers**, allowing for manufacturing flexibility without increased costs, and with even faster lead-times. Contact ecustomerservice@samtec.com to learn more.

24/7 WORLDWIDE ACCESS

Samtec is the Electronics Industry's Service & Technology Leader.

Technical Support

Signal Integrity Group: sig@samtec.com

Application Support Group: asg@samtec.com

Interconnect Processing Group: ipg@samtec.com

Supply Chain Support

MySamtec™ Real-Time Account Access: account.samtec.com

Personal Account Managers & CSRs: ecustomerservice@samtec.com

Upfront, Aggressive 24-Hour Quotes: pricing@samtec.com



Online Tools

FIND, DESIGN & VALIDATE YOUR SOLUTION

Samtec has developed innovative search, design, and validation tools to help customers quickly and easily find the right solution. Whether you prefer to search by product name or characteristics, browse through pictures, or build an assembly by entering physical specifications, Samtec offers a tool to make your search easier than ever.



Picture Search
VISUALLY FIND YOUR SOLUTION

Browse through a highlight reel of Samtec's most popular products to find the ideal solution for your application, view specifications, check availability, order samples and more. To find your solution, visit samtec.com/picturesearch.



Cable Builder
HIGH-SPEED ASSEMBLIES DESIGNED IN MINUTES

Input specific options to quickly build a complete high-speed cable assembly, view specs, prints, 3D models and instantly request samples and quotes. Visit samtec.com/cablebuilder.

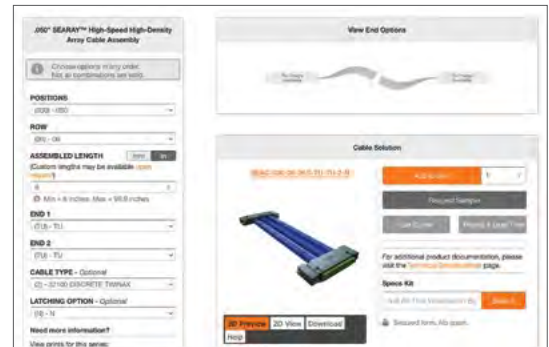

Solutionator
DESIGN IN A MINUTE

Quickly build mated connector sets using a wide variety of user-defined search parameters and filters, view specs and order samples all with one online design tool. Visit samtec.com/solutionator to start building.



Simulator
SIMULATE IN A MINUTE

Innovative design tool blends data to project performance in a user-defined system, providing insertion loss, crosstalk, eye diagrams, sample requests and more. Visit samtec.com/simulator.

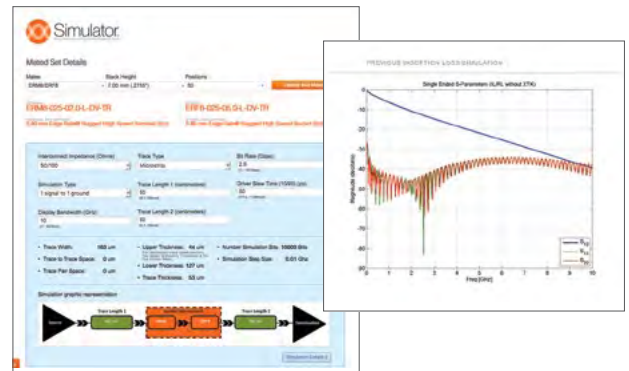

Samtec is committed to the continuous evolution of our award-winning website, providing customers with innovative design tools, technical resources and support needed to make **finding, designing and ordering** the right product as easy and streamlined as possible.



Downloads

3D MODELS, SPECS, PRINTS & MORE

Samtec's extensive library of downloadable resources is unmatched in the industry. From 3D Models and Test Reports, Interconnect Symbols and Footprints, Product Videos, Design Guides, Specifications and so much more – Samtec offers immediate and unlimited access to all the documentation you need to select the right solution for your application. Visit samtec.com to start exploring.

3D Models

Quickly configure, preview and download models in more than 150 different formats, including AutoCad, Solid Edge, Inventor and many more.

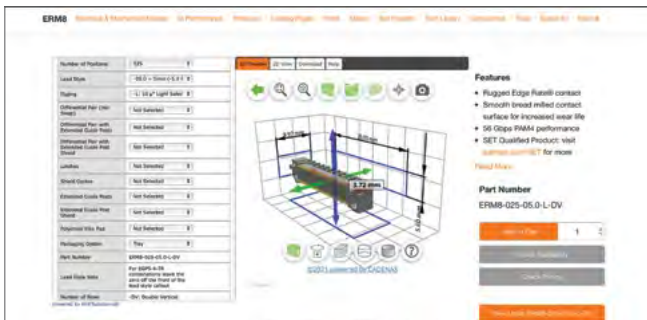

Test Reports

Samtec provides immediate access to a variety of testing and qualification reports for our products, including high-speed characterization, thermal, frequency and time domain, Extended Life Product™, Severe Environment Testing, and others.

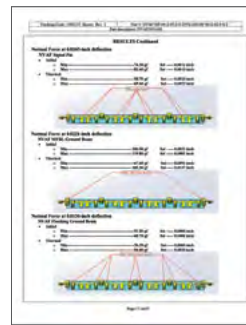

PCB Footprint / eCAD Models

Instantly view, download and design with over 200,000 ready-to-use eCAD models.

These detailed models have been formatted to work with leading schematic captures and include accurate assembly, silkscreen and 3D features.



Technical Library

Samtec's online Technical Library contains a wealth of resources, including Prints & Specifications, White Papers, Application Notes, Test Reports, Product Videos, Design Guides, Processing Information and much more.

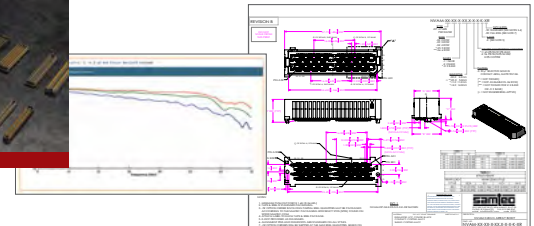
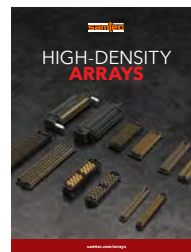

MODIFIED & CUSTOM SOLUTIONS

INDUSTRY-LEADING SUPPORT & EXPERTISE

Visit samtec.com/custom for details.

- Full engineering, design and prototype support
- Design, simulation and processing assistance
- Dedicated Application Specific Product engineers and technicians
- Industry-leading Customer Service
- Quotes and samples turned around in 24 hours
- Flexible, quick-turn in-house manufacturing
- Customer specific testing - AS9102 FAIs available
- ITAR compliant with U.S. based manufacturing
- Contact the Application Specific Products Group at asp@samtec.com to discuss your application

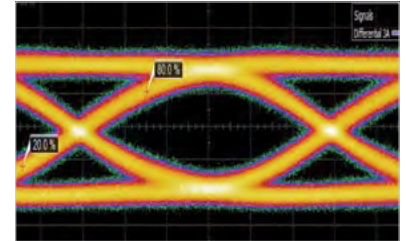
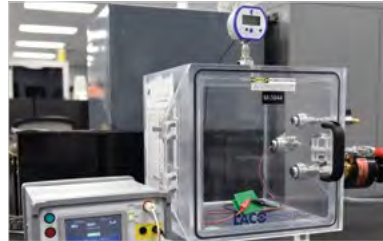

EXPRESS MODIFICATIONS & ENGINEERED CUSTOMS

- Up to 50 μ " Gold and Tin Lead plating available
- Polarized positions
- Modified stack heights, latching and screw downs
- Modified contacts, bodies, stamping, plating, wiring, molding and much more
- Ruggedizing features including strain relief, plastic housings, screw downs, latches, locks, etc.
- Mix-and-match cable end options for application specific requirements
- Many non-cataloged cable standards available, including 75 Ω micro coax & high-density twinax solutions
- Solutions for Optics in extreme environments (in development): Samtec MIL-coat protected, salt-fog impenetrable, mitigation for tin whiskers, fungal resistant, extreme shock and vibration, full support for liquid immersion cooling

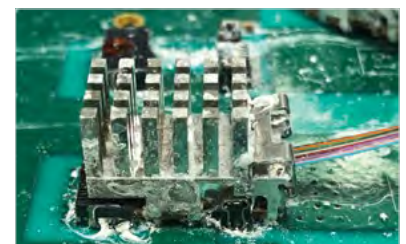
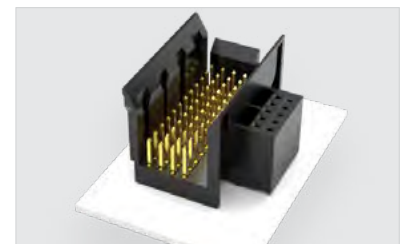
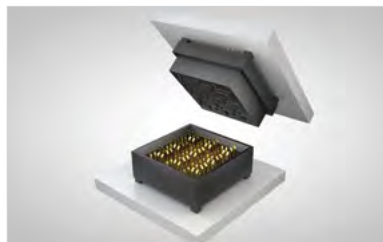

HIGH-SPEED HIGH-DENSITY ARRAYS

EXTREME DENSITY • HIGH-PERFORMANCE • MAXIMUM DESIGN FLEXIBILITY

16-17

NOVARAY® EXTREME DENSITY & PERFORMANCE ARRAYS (NVAM, NVAF)



NOVARAY®

18-19

0.635 mm PITCH ACCELERATE® HP HIGH-PERFORMANCE ARRAYS (APM6, APF6)

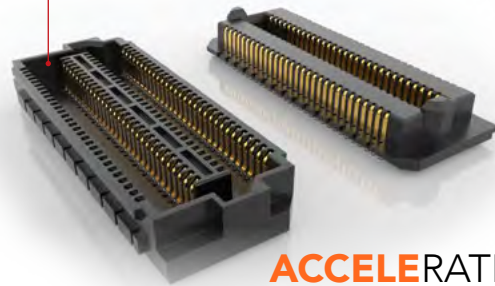

ACCELERATE®HP

20-21

0.635 mm PITCH ACCELERATE® HD HIGH-DENSITY ARRAYS (ADM6, ADF6)

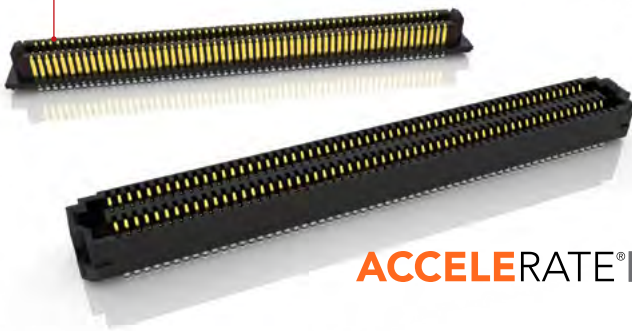

ACCELERATE®HD

22-25

1.27 mm PITCH SEARAY™ OPEN-PIN-FIELD ARRAYS (SEAF, SEAM)



SEARAY™

26-27

SEARAY™ 0.80 mm PITCH OPEN-PIN-FIELD ARRAYS (SEAM8, SEAF8)



SEARAY™.8mm

28-29

1.27 mm PITCH LP ARRAY™ LOW-PROFILE ARRAYS (LPAM, LPAF)

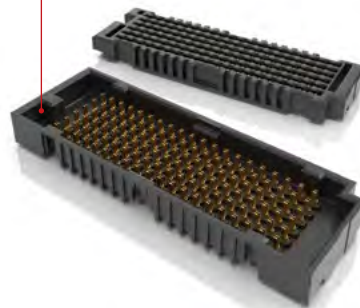

LPARRAY™



EXTREME PERFORMANCE HIGH-DENSITY ARRAYS

(0.80 mm) .0315" x (1.80 mm) .071" PITCH



FEATURES & BENEFITS

- 112 Gbps PAM4 per channel
- 112 fully shielded differential pairs per square inch
- 4.0 Tbps aggregate data rate - 9 IEEE, 400 G channels
- Extremely low crosstalk to 40 GHz+
- Incredibly tight impedance control
- Minimal variance in data rate as stack height increases
- 40% less space vs traditional arrays with the same data throughput

NRZ	PAM4
56 Gbps	112 Gbps



High-speed mezzanine connector and cable in one product family



BGA attach to board for greater density and optimized trace breakout region



Guaranteed two points of contact to ensure a more reliable connection

KEY SPECIFICATIONS

STACK HEIGHTS	TOTAL PAIRS	INSULATOR MATERIAL	CONTACT MATERIAL	PLATING	CURRENT RATING	WORKING VOLTAGE	LEAD-FREE SOLDERABLE
7 mm & 10 mm	Up to 32 pairs	Black LCP	Copper Alloy	Au or Sn over 50 μ" (1.27 μm) Ni	2.1 A per pin (signal) 9.6 A per pin (ground)	200 VAC	Yes

0.80 mm x 1.80 mm PITCH • EXTREME PERFORMANCE ARRAYS

SERIES	STYLE	NO. OF ROWS	NO. OF BANKS	LEAD STYLE	PLATING OPTION	SOLDER TYPE	K	"X"R
NVAM Terminal	-DP = 4 pairs per wafer	-02	-1 = 1 Bank	-02.0 = (2 mm) .0787" (NVAM only)	-S = 30 μm (0.76 μm) Gold on contact area, Matte Tin on solder tail	-2 = Lead-Free Solder Charge	-K = (3.50 mm) .138" DIA Polyimide film Pick & Place Pad	-TR = Tape & Reel
NVAF Socket		-03	-2 = 2 Banks	-05.0 = (5 mm) .1969"				-FR = Full Reel Tape & Reel (must order maximum quantity per reel; contact Samtec for quantity breaks)
		-04						

NVAM
Board Mates:
NVAF

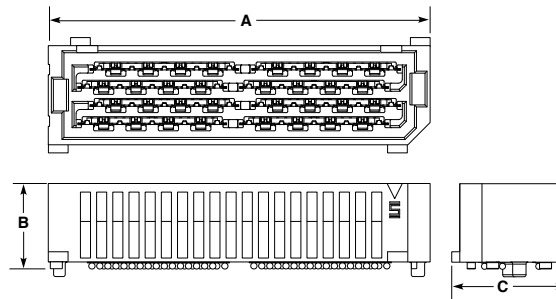

PRELIMINARY

NO. OF BANKS	A	LEAD STYLE	B	NO. OF ROWS	C
-1	(21.75) .856	-02.0	(5.46) .215	-02	(7.80) .307
-2	(37.75) 1.486	-05.0	(8.46) .333	-03	(9.60) .378
				-03	(11.40) .449

View complete specifications at: samtec.com?NVAM

NVAF
Board Mates:
NVAM

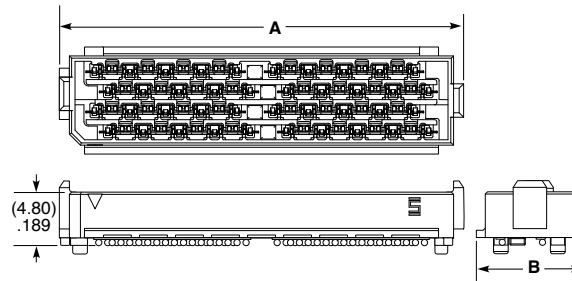
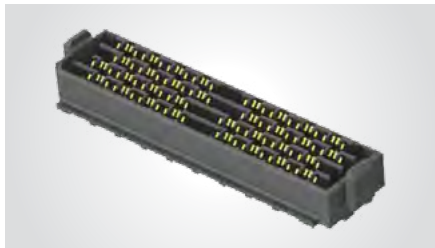

PRELIMINARY

NO. OF BANKS	A
-1	(20.25) .797
-2	(36.25) 1.427

NO. OF ROWS	B
-02	(6.00) .236
-03	(7.80) .307
-03	(9.60) .378

MATED HEIGHTS*		
NVAF LEAD STYLE	NVAM LEAD STYLE	
	-02.0	-05.0
-05.0	(7.00) .276	(10.00) .394

AGGREGATE DATA RATE (NRZ)					
448 Gbps	672 Gbps	896 Gbps	1344 Gbps	1792 Gbps	
1 Bank			2 Bank		
2 Row	3 Row	4 Row	2 Row	3 Row	4 Row
8 Pairs	12 Pairs	16 Pairs	24 Pairs	32 Pairs	

*Processing conditions will affect mated height.

Notes:
Some sizes, styles and options are non-standard, non-returnable

View complete specifications at: samtec.com?NVAF

HIGH-PERFORMANCE ARRAY SYSTEM

(0.635 mm) .025" PITCH

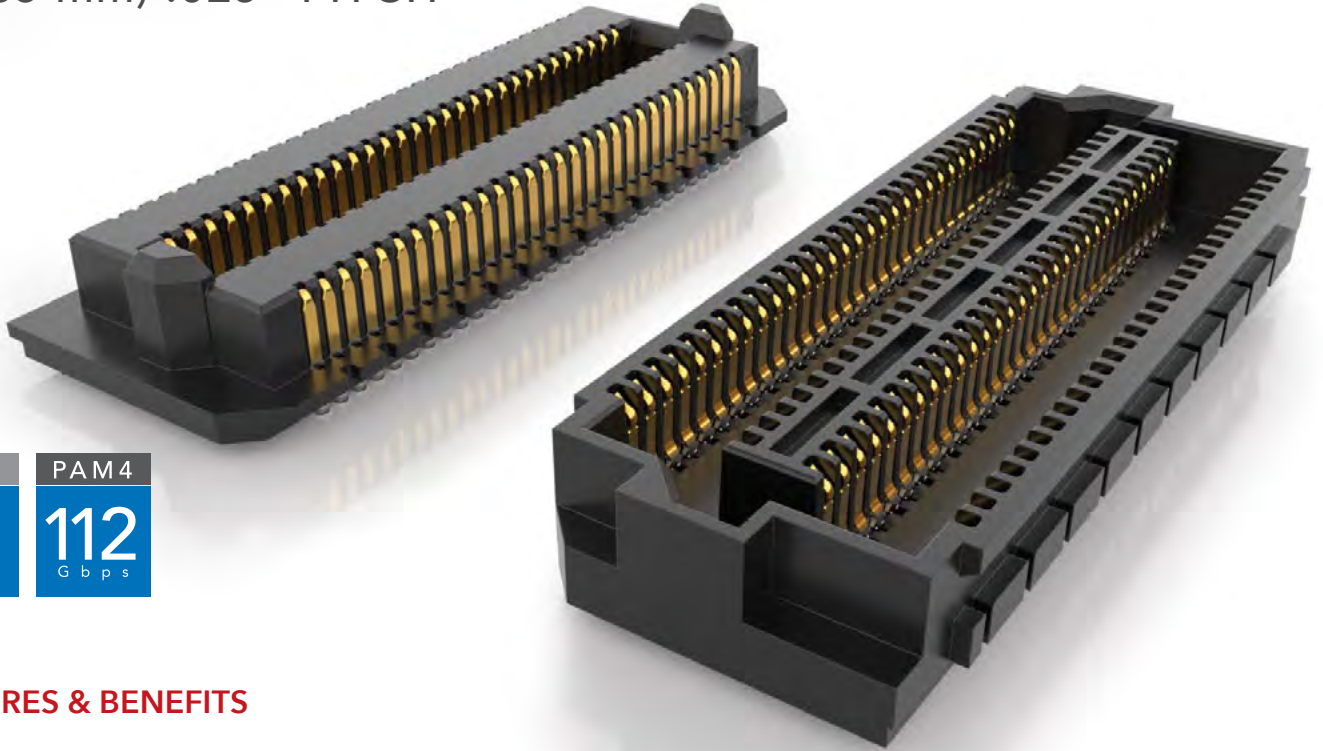

NRZ	PAM4
56 Gbps	112 Gbps

FEATURES & BENEFITS

- Flexible open-pin-field and cost optimized, extreme performance solution
- Low-profile 5 mm stack height and up to 10 mm
- 0.635 mm pitch
- Four row design with up to 400 total pins; roadmap to 1,000+ pins
- Data rate capable of PCIe[®] Gen 5 and 100 GbE
- In Development: Cable assembly designs, 6, 8 and 10 rows, additional position counts



Solder ball technology for simplified processing

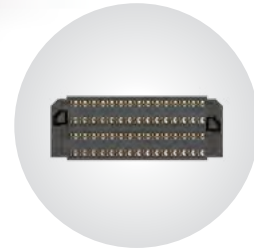

APF6 Sereis; 120 pins (actual size show)

KEY SPECIFICATIONS

STACK HEIGHTS	TOTAL PINS	INSULATOR MATERIAL	CONTACT MATERIAL	PLATING	OPERATING TEMP RANGE	LEAD-FREE SOLDERABLE
5 mm - 10 mm	40 - 400	Black LCP	Copper Alloy	Au or Sn over 50 μ" (1.27 μm) Ni	-55 °C to +125 °C	Yes

(0.635 mm) .025" PITCH • 112 Gbps PAM4 OPEN-PIN-FIELD ARRAYS

SERIES	NO. OF POSITIONS	LEAD STYLE	PLATING OPTION	NO. OF ROWS	SOLDER TYPE	OPTION
APM6 Terminal	-020, -060, -100 (per row)	-01.5 = 1.5 mm (APM6 only)	-L = 10 μ " (0.25 μ m) Gold on contact area, Matte Tin on tail	-04 = Four Rows	-2 = Lead-Free Solder Balls	(Leave blank for no alignment pin) -A = Alignment Pin
APF6 Socket		-06.5 = 6.5 mm (APM6 only) 03.50 = 3.5 mm (APF6 only)	-S = 30 μ " (0.76 μ m) Gold on contact area, Matte Tin on tail			

APM6
Board Mates:
APF6

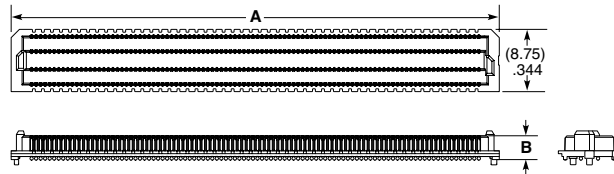
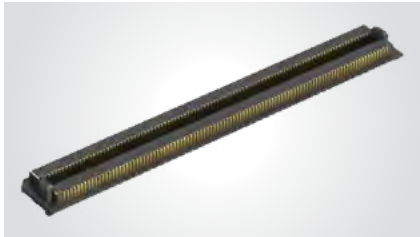

NO. OF POSITIONS PER ROW	A	LEAD STYLE	B
-020	(17.82) .701	-01.5	(3.33) .131
-060	(43.22) 1.701	-06.5	(8.33) .328
-100	(68.62) 2.701		

PRELIMINARY

View complete specifications at: samtec.com?APM6

MATED HEIGHTS *		
APF6 LEAD STYLE	APM6 LEAD STYLE	
	-01.5	06.5
-03.5	(5.00 mm) .197"	(10.00 mm) .394"

* Processing conditions will affect mated height.

APF6
Board Mates:
APM6

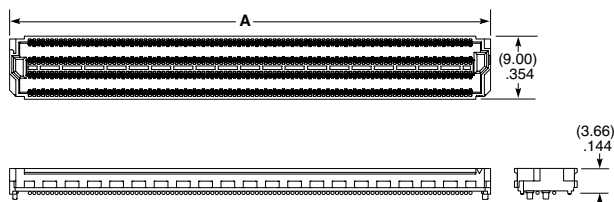

NO. OF POSITIONS PER ROW	A
-020	(17.82) .701
-060	(43.22) 1.701
-100	(68.62) 2.701

PRELIMINARY

View complete specifications at: samtec.com?APF6

Notes:
Some sizes, styles and options are non-standard, non-returnable

ACCELERATE[®] HD

HIGH-DENSITY SLIM BODY ARRAYS

(0.635 mm) .025" PITCH

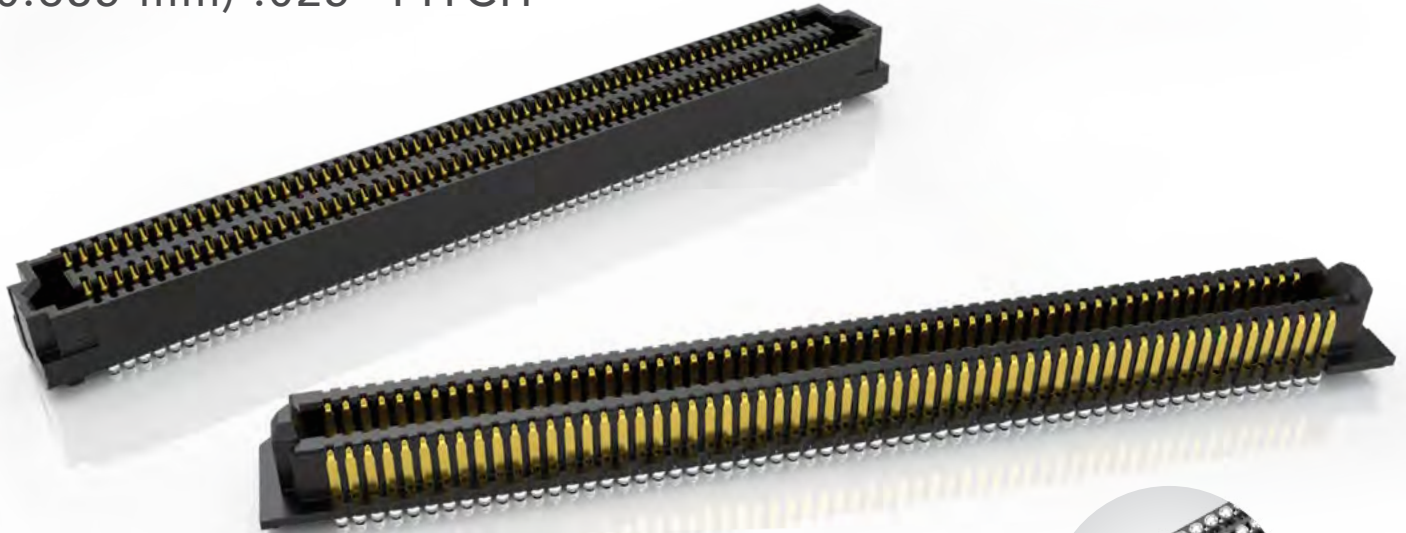

FEATURES & BENEFITS

- Up to 240 positions in 4-row design (400 positions in development)
- Low-profile 5 mm stack heights
- Slim 5 mm width body design
- Edge Rate[®] contact system optimized for signal integrity performance
- Open-pin-field for grounding and routing flexibility
- Right-angle (ADF6-RA) and other stack heights in development
- PCIe[®] 5.0 capable
- Compatible with mPower[®] (UMPT/UMPS) for a power signal solution

PAM 4
56
G b p s



Solder ball technology
for simplified processing

HIGHER DENSITY THAN PREVIOUS GENERATION STRIPS

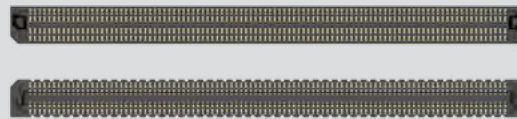

Actual Size Shown
(68.22 mm x 5.00 mm)

ADM6/ADF6 Series (400 total positions)

KEY SPECIFICATIONS

PITCH	TOTAL POSITIONS	INSULATOR MATERIAL	CONTACT MATERIAL	PLATING	OPERATING TEMP RANGE	CURRENT RATING	WORKING VOLTAGE	LEAD-FREE SOLDERABLE
(0.635 mm) .025"	40 - 240	Black LCP	Copper Alloy	Au or Sn over 50 μ " (1.27 μ m) Ni	-55 °C to +125 °C	1.34 A per pin (4 pins powered)	Testing now	Yes

(0.635 mm) .025" PITCH • SLIM BODY OPEN-PIN-FIELD ARRAYS

SERIES	NO. OF POSITIONS	LEAD STYLE	PLATING OPTION	NO. OF ROWS	SOLDER TYPE	OPTION	"X" R
ADM6 Terminal	-10, -20, -30, -40, -50, -60 (per row)	-01.5 = 1.5 mm (ADM6 only)	-L = 10 μ" (0.25 μm) Gold on contact area, Matte Tin on tail	-04 = Four Rows	-2 = Lead-Free Solder Ball	(Leave blank for no alignment pin)	-TR = Tape & Reel
ADF6 Socket		-03.50 = 3.5 mm (ADF6 only)				-A = Alignment Pin	-FR = Full Reel Tape & Reel (must order max. quantity per reel; contact Samtec for quantity breaks)

ADM6

Board Mates:
ADF6

Standoffs:
JSO

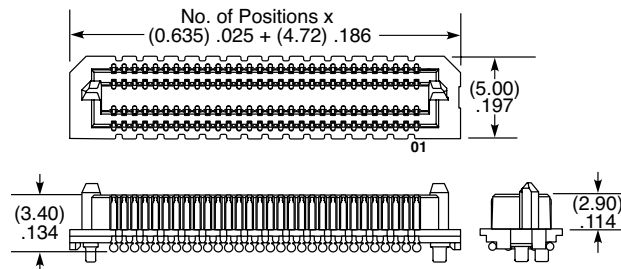

View complete specifications at: samtec.com?ADM6

MATED HEIGHTS *	
ADF6 LEAD STYLE	ADM6 LEAD STYLE
-03.5	-01.5
	(5 mm) .197"

* Processing conditions will affect mated height.

ADF6

Board Mates:
ADM6

Standoffs:
JSO

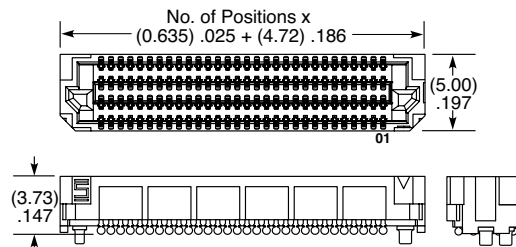

Notes:

Some sizes, styles and options are non-standard, non-returnable

View complete specifications at: samtec.com?ADF6

SEARAY™

HIGH-DENSITY OPEN-PIN-FIELD ARRAYS

(1.27 mm) .050" PITCH

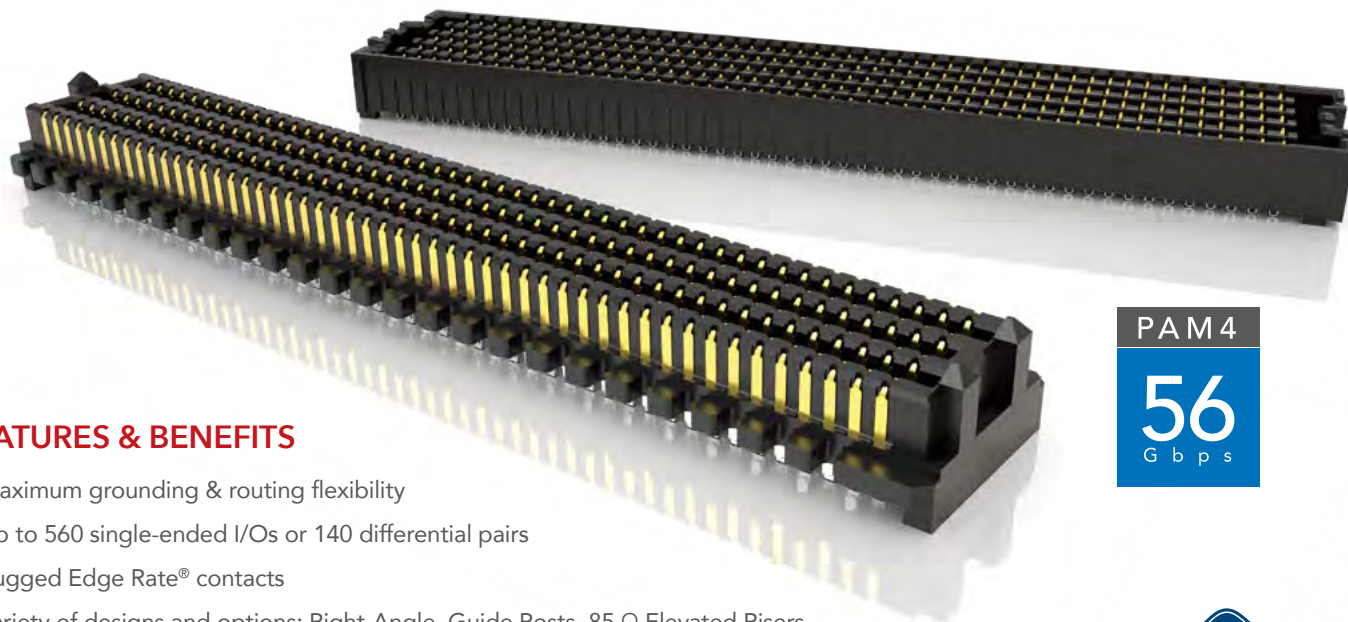

FEATURES & BENEFITS

- Maximum grounding & routing flexibility
- Up to 560 single-ended I/Os or 140 differential pairs
- Rugged Edge Rate® contacts
- Variety of designs and options: Right-Angle, Guide Posts, 85 Ω Elevated Risers, 85 Ω Tuned, Press-Fit and Press-Fit Right-Angle, Guide Post Field Termination Kits
- Compatible with UMPT/UMPS for power/signal flexibility
- Cable mates (SEAC Series) and Jack Screw Standoffs (JSO Series) also available
- Standards: VITA 47, VITA 57.1 FMC, VITA 57.4 FMC+, VITA 74 VNX, PISMO™ 2
- Supports high-speed protocols such as Ethernet, PCI Express®, Fibre Channel & InfiniBand

PAM 4
56
Gbps

EDGE
RATE
CONTACT

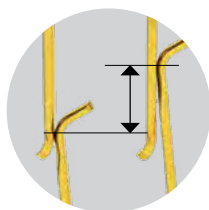

(1.12 mm) .044"
Nominal Wipe



Solder Charges



Power / Signal
Applications

MAXIMUM GROUNDING & ROUTING FLEXIBILITY

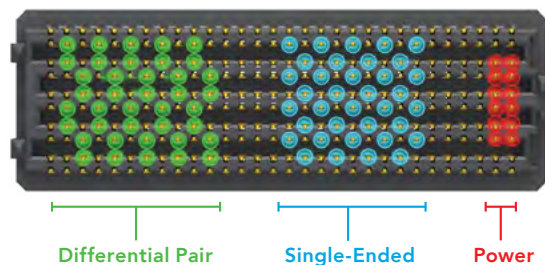

KEY SPECIFICATIONS

PITCH	STACK HEIGHTS	TOTAL PINS	INSULATOR MATERIAL	CONTACT MATERIAL	PLATING	OPERATING TEMP RANGE	CURRENT RATING	WORKING VOLTAGE	LEAD-FREE SOLDERABLE
1.27 mm x 1.27 mm	7 mm - 18.5 mm	40 - 560	Black LCP	Copper Alloy	Au or Sn over 50 μ" (1.27 μm) Ni	-55 °C to +125 °C	2.7 A per pin (10 adjacent pins powered) 7 mm stack height	240 VAC	Yes

Note: Some lengths, styles and options are non-standard, non-returnable

samtec.com/SEARAY

Unless otherwise approved in writing by Samtec, all parts and components are designed and built according to Samtec's specifications which are subject to change without notice.

(1.27 mm) .050" PITCH • SEAM/SEAF SERIES

SERIES	POSITIONS PER ROW	LEAD STYLE	PLATING OPTION	NO. OF ROWS	SOLDER TYPE	A	K	"X" R
SEAM Terminal	-10, -15, -20, -30, -40, -50	Specify LEAD STYLE from chart	-L = 10 μ" (0.25 μm) Gold on contact area, Matte Tin on solder tail	-04	-1 = Tin/Lead Alloy Solder Charge	-A = Alignment Pin	-K Polyimide Film Pick & Place Pad	-TR = Tape & Reel
SEAF Socket	SEAM & SEAF: -10 only available in -04 Row SEAM: -15 only available in -04 Row with -02.0 Lead Style, and -10 Row with any Lead Style; SEAF: -15 only available in -04 or -10 Row with -5.0 Lead Style		-S = 30 μ" (0.76 μm) Gold on contact area, Matte Tin on solder tail	-05 -06 -08 -10 SEAM: -04, -05 & -06 (Rows not available with -06.5 Lead Style)	-2 = Lead-Free Solder Charge			

SEAM

Board Mates:
SEAF, SEAFP
Standoffs:
JSO

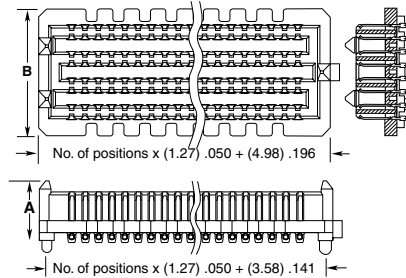
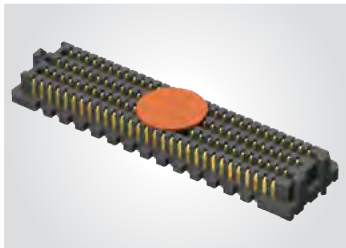

LEAD STYLE	A	NO. OF ROWS	B
-02.0	(4.60) .181	-04	(7.06) .278
-03.0	(5.59) .220	-05, -06	(9.60) .378
-03.5	(6.10) .240	-08	(12.14) .478
-06.5	(9.14) .360	-10	(14.68) .578
-07.0	(9.60) .378		
-09.0	(11.60) .457		
-11.0	(13.60) .535		

ALSO AVAILABLE
See website for 14 row option.

View complete specifications at: samtec.com?SEAM

SEAF

Board Mates:
SEAM, SEAMP,
SEAR, SEAMI
Cable Mates:
SEAC
Standoffs:
JSO

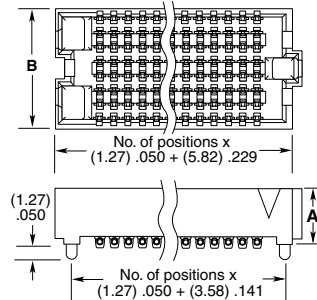
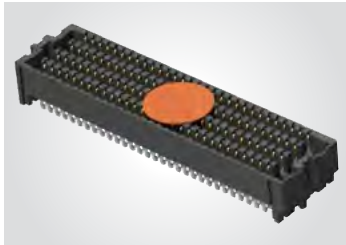

LEAD STYLE	A	NO. OF ROWS	B
-05.0	(5.05) .199	-04	(5.66) .223
-06.0	(6.05) .238	-05, -06	(8.20) .323
-06.5	(6.55) .258	-08	(10.74) .423
-07.5	(7.54) .297	-10	(13.28) .523

View complete specifications at: samtec.com?SEAF

MATED HEIGHTS				
SEAM LEAD STYLE	SEAF LEAD STYLE			
	-05.0	-06.0	-06.5	-07.5
-02.0	7 mm	8 mm	8.5 mm	9.5 mm
-03.0	8 mm	9 mm	9.5 mm	10.5 mm
-03.5	8.5 mm	9.5 mm	10 mm	11 mm
-06.5	11.5 mm	12.5 mm	13 mm	14 mm
-07.0	12 mm	13 mm	13.5 mm	14.5 mm
-09.0	14 mm	15 mm	15.5 mm	16.5 mm
-11.0	16 mm	17 mm	17.5 mm	18.5 mm

STANDARDS
VITA 47
VITA 57.1 FMC
VITA 57.4 FMC+
VITA 74 VNX
PISMO™2
Visit www.samtec.com/standards for more information.

Notes:
IPC-A-610F and
IPC J-STD-001F Class 3 solder joint.

(1.27 mm) .050" PITCH • RIGHT-ANGLE & GUIDE POST

SERIES	POSITIONS PER ROW	01	PLATING OPTION	NO. OF ROWS	SOLDER TYPE	RA	OPTIONS	"X"R
SEAM Right-Angle Terminal	-20		-L = 10 μ" (0.25 μm) Gold on contact area, Matte Tin on solder tail	-04	-1 = Tin/Lead Alloy Solder Charge		-GP = Guide Post/Hole	-TR = Tape & Reel
	-30			-06			-K = Polyimide Film Pick & Place Pad	-FR = Full Reel Tape & Reel (must order max. quantity per reel; contact Samtec for quantity breaks)
	-40			-08				
SEAF Right-Angle Socket	-50		-S = 30 μ" (0.76 μm) Gold on contact area, Matte Tin on solder tail	-10	-2 = Lead-Free Solder Charge		-LP Latch Post (Available with SEAF in -06 Row with 30 positions only; Required for mating to SEAC)	
				-08 & -10 Row options require fixturing to process				

SEAM-RA

Board Mates:
SEAF, SEAF-RA, SEAFP

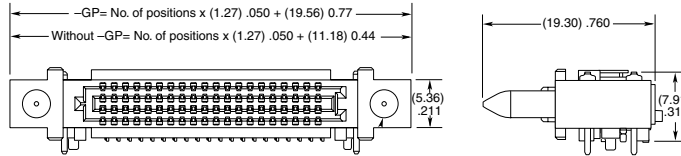

SEAF-RA

Board Mates:
SEAM, SEAFP

Cable Mates:
SEAC

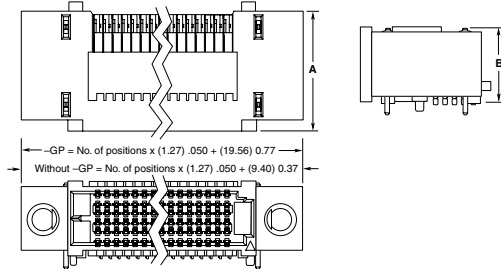

NO. PINS PER ROW	A	B
-04	(13.77) .542	(7.91) .311
-06	(16.31) .642	(10.45) .411
-08	(18.85) .742	(12.99) .511
-10	(21.39) .842	(15.53) .611

View complete specifications at: samtec.com?SEAM-RA & samtec.com?SEAF-RA

SERIES	POSITIONS PER ROW	02.0	PLATING OPTION	NO. OF ROWS	SOLDER TYPE	A	GP	K	"X"R
SEAM Terminal with Guide post	-20, -30, -40, -50		-L = 10 μ" (0.25 μm) Gold on contact area, Matte Tin on solder tail	-04	-1 = Tin/Lead Alloy Solder Charge				-TR = Tape & Reel
				-06					-FR = Full Reel Tape & Reel (must order max. quantity per reel; contact Samtec for quantity breaks)
				-08					
SEAM-GP Board Mates: SEAF-RA-GP			-S = 30 μ" (0.76 μm) Gold on contact area, Matte Tin on solder tail	-10	-2 = Lead-Free Solder Charge				

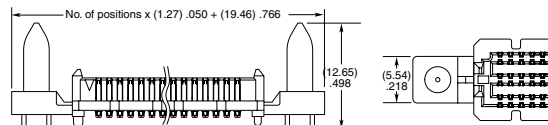
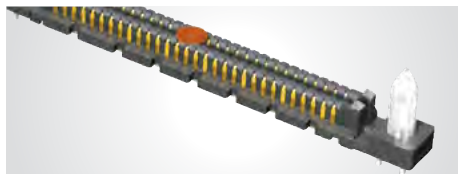

View complete specifications at: samtec.com?SEAM

Note: Some lengths, styles and options are non-standard, non-returnable

(1.27 mm) .050" PITCH • PRESS-FIT & 85 Ω OPEN-PIN-FIELD ARRAYS

SERIES	POSITIONS PER ROW	LEAD STYLE	PLATING OPTION	NO. OF ROWS	OPTION	PACKAGING										
SEAMP Terminal	-10, -20, -30, -40, -50	-02.0 (SEAMP only)	-L = 10 μ" (0.25 μm) Gold on contact area, Matte Tin on tail	-04, -06, -08, -10	-GP Guide Post (SEAMP only)	-TR = Tape & Reel										
SEAFP Socket		-05.0 (SEAFP only)	-S = 30 μ" (0.76 μm) Gold on contact area, Matte Tin on tail	SEAFP: -04 & -06 Rows only		-FR = Full Reel Tape & Reel (must order max. quantity per reel; contact Samtec for quantity breaks)										
SEAMP Board Mates: SEAF, SEAF-RA-GP, SEAFP					<table border="1"> <thead> <tr> <th>NO. OF ROWS</th> <th>A</th> </tr> </thead> <tbody> <tr> <td>-04</td> <td>(7.06) .278</td> </tr> <tr> <td>-06</td> <td>(9.60) .378</td> </tr> <tr> <td>-08</td> <td>(12.14) .478</td> </tr> <tr> <td>-10</td> <td>(14.68) .578</td> </tr> </tbody> </table>	NO. OF ROWS	A	-04	(7.06) .278	-06	(9.60) .378	-08	(12.14) .478	-10	(14.68) .578	
NO. OF ROWS	A															
-04	(7.06) .278															
-06	(9.60) .378															
-08	(12.14) .478															
-10	(14.68) .578															

SERIES	POSITIONS PER ROW	LEAD STYLE	NO. OF ROWS	OPTION	PACKAGING							
SEAFP Board Mates: SEAM, SEAM-RA					<table border="1"> <thead> <tr> <th>NO. OF ROWS</th> <th>A</th> </tr> </thead> <tbody> <tr> <td>-04</td> <td>(5.61) .221</td> </tr> <tr> <td>-06</td> <td>(8.15) .321</td> </tr> </tbody> </table>	NO. OF ROWS	A	-04	(5.61) .221	-06	(8.15) .321	
NO. OF ROWS	A											
-04	(5.61) .221											
-06	(8.15) .321											
Cable Mates: SEAC												

View complete specifications at: samtec.com?SEAMP & samtec.com?SEAFP. Visit samtec.com?SEAFP-RA for right-angle socket.

SERIES	POSITIONS PER ROW	LEAD STYLE	NO. OF ROWS	085															
SEAR 85 Ω Tuned Riser	-40, -50	-10.0 = 20 mm Mated Height -20.0 = 30 mm Mated Height -30.0 = 40 mm Mated Height	-06, -08, -10																
SEAR Board Mates: SEAF				<table border="1"> <thead> <tr> <th>POSITIONS PER ROW</th> <th>A</th> </tr> </thead> <tbody> <tr> <td>-40</td> <td>(71.42) 2.812</td> </tr> <tr> <td>-50</td> <td>(84.12) 3.312</td> </tr> </tbody> </table> <table border="1"> <thead> <tr> <th>NO. OF ROWS</th> <th>B</th> </tr> </thead> <tbody> <tr> <td>-06</td> <td>(11.43) .450</td> </tr> <tr> <td>-08</td> <td>(13.97) .550</td> </tr> <tr> <td>-10</td> <td>(16.51) .650</td> </tr> </tbody> </table>	POSITIONS PER ROW	A	-40	(71.42) 2.812	-50	(84.12) 3.312	NO. OF ROWS	B	-06	(11.43) .450	-08	(13.97) .550	-10	(16.51) .650	
POSITIONS PER ROW	A																		
-40	(71.42) 2.812																		
-50	(84.12) 3.312																		
NO. OF ROWS	B																		
-06	(11.43) .450																		
-08	(13.97) .550																		
-10	(16.51) .650																		

SERIES	POSITIONS PER ROW	11.0	PLATING OPTION	NO. OF ROWS	SOLDER TYPE	A	K	"X"R						
SEAMI 85 Ω Tuned Terminal	-40 -50		-L = 10 μ" (0.25 μm) Gold on contact area, Matte Tin on solder tail	-08 -10	-1 = Tin/Lead Alloy SolderCharge			-TR = Tape & Reel						
SEAMI Board Mates: SEAF			-S = 30 μ" (0.76 μm) Gold on contact area, Matte Tin on solder tail		-2 = Lead-Free Solder Charge			-FR = Full Reel Tape & Reel (must order max. quantity per reel; contact Samtec for quantity breaks)						
Note: Some lengths, styles and options are non-standard, non-returnable								<table border="1"> <thead> <tr> <th>NO. OF ROWS</th> <th>A</th> </tr> </thead> <tbody> <tr> <td>-08</td> <td>(13.41) .528</td> </tr> <tr> <td>-10</td> <td>(15.95) .628</td> </tr> </tbody> </table>	NO. OF ROWS	A	-08	(13.41) .528	-10	(15.95) .628
NO. OF ROWS	A													
-08	(13.41) .528													
-10	(15.95) .628													

View complete specifications at: samtec.com?SEAR & samtec.com?SEAMI.

SEARAYTM.8mm

ULTRA HIGH-DENSITY, HIGH-SPEED OPEN-PIN-FIELD ARRAYS

(0.80 mm) .0315" PITCH

NRZ	PAM4
28 Gbps	56 Gbps

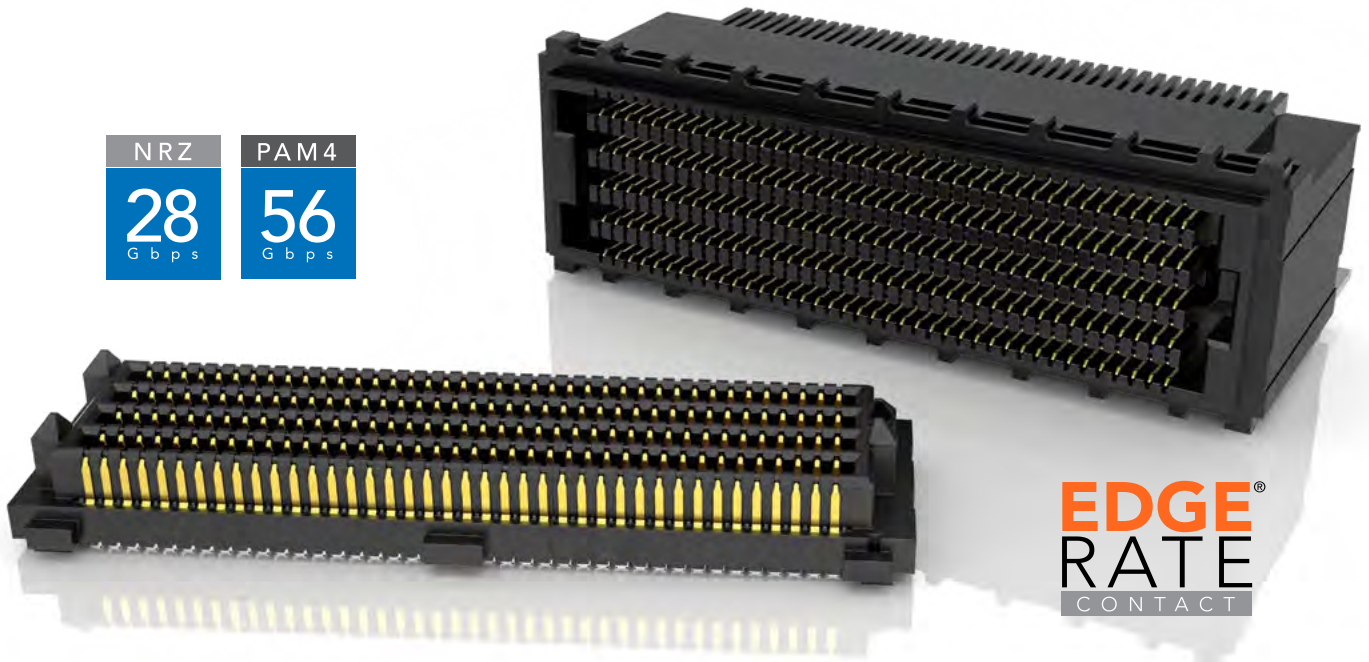

EDGE[®]
RATE
CONTACT

FEATURES & BENEFITS

- 0.80 mm (.0315") pitch grid
- 50% board space savings versus .050" (1.27 mm) pitch arrays
- Performance up to 28 Gbps NRZ/56 Gbps PAM4
- Rugged Edge Rate[®] contact system
- Up to 720 I/Os
- 7 mm and 10 mm stack heights
- Solder charge terminations for ease of processing
- Lower insertion/withdrawal forces

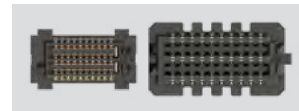

0.80 mm pitch vs. 1.27 mm pitch
(actual size shown; 60 pins)

MAXIMUM GROUNDING & ROUTING FLEXIBILITY

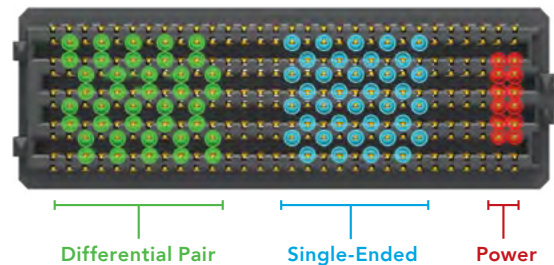

KEY SPECIFICATIONS

PITCH	STACK HEIGHTS	TOTAL PINS	INSULATOR MATERIAL	CONTACT MATERIAL	PLATING	CURRENT RATING	LEAD-FREE SOLDERABLE
0.80 mm	7 mm & 10 mm	up to 720 I/Os	Black LCP	Copper Alloy	Au or Sn over 50 μ" (1.27 μm) Ni	1.3 A per pin (10 adjacent pins powered)	Yes

(0.80 mm) .0315" PITCH • ULTRA HIGH-DENSITY ARRAYS

SERIES	NO. PINS PER ROW	LEAD STYLE	PLATING OPTION	NO. OF ROWS	SOLDER TYPE	OPTION	K	"X"R
SEAM8 Terminal	-10, -20, -30, -40, -50	-S02.0 = 2 mm Body Height (SEAM8 only)	-L = 10 μ" (0.25 μm) Gold on contact area, Matte Tin on solder tail	-04 -06 -08 -10	-2 = Lead-Free Solder Crimp	-GP = Guide Post (-S02.0 lead style only) (Mates with SEAF8-RA-GP)	Leave blank for SEAM8 -K = Polyimide film Pick & Place Pad	Tape & Reel is standard. Leave blank for Tape & Reel. -FR = Full Reel Tape & Reel (must order max. quantity per reel; contact Samtec for quantity breaks)
SEAF8 Socket		-S05.0 = 5 mm Body Height (SEAM8 only)	-S = 30 μ" (0.76 μm) Gold on contact area, Matte Tin on solder tail					

SEAM8
Board Mates:
SEAF8
Cable Mates:
ESCA
Standoffs:
JSO

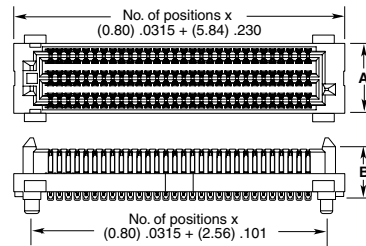
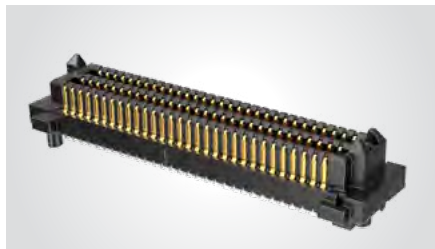

NO. OF ROWS	A
-04	(4.30) .169
-06	(6.30) .248
-08	(8.30) .327
-10	(10.30) .406

LEAD STYLE	B
-S02.0	(4.54) .179
-S05.0	(7.54) .297

SEAF8
Board Mates:
SEAM8
Cable Mates:
ESCA
Standoffs:
JSO

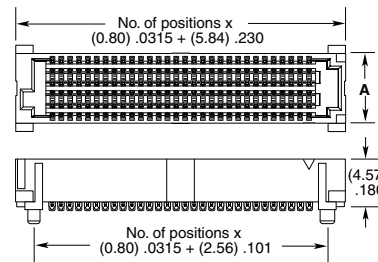

MATED HEIGHTS*		
SEAF8 LEAD STYLE	SEAM8 LEAD STYLE	
	-S02.0	-S05.0
-05.0	(7.00) .276	(10.00) .394

*Processing conditions will affect mated height.

View complete specifications at: samtec.com?SEAF8

SEAF8	NO. PINS PER ROW	1	PLATING OPTION	NO. OF ROWS	SOLDER TYPE	RA	OPTION	"X"R
	-20, -30, -40, -50		-L = 10 μ" (0.25 μm) Gold on contact area, Matte Tin on solder tail	-08 -10	-2 = Lead-Free Solder Crimp		-GP = Guide Post Holes	Tape & Reel is standard. Leave blank for Tape & Reel. -FR = Full Reel Tape & Reel (must order max. quantity per reel; contact Samtec for quantity breaks)
			-S = 30 μ" (0.76 μm) Gold on contact area, Matte Tin on solder tail					

PRELIMINARY

SEAF8-RA
(Right-angle)
Board Mates:
SEAM8
Cable Mates:
ESCA



NO. PINS PER ROW	C	D
-20	(29.62) 1.166	(24.12) .950
-30	(37.62) 1.481	(32.12) 1.265
-40	(45.62) 1.796	(40.12) 1.580
-50	(53.62) 2.111	(48.12) 1.894

NO. OF ROWS	A	B
-08	(16.48) .649	(11.46) .451
-10	(18.48) .728	(13.46) .530

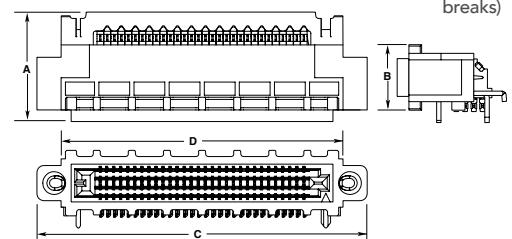

Notes:
Some sizes, styles and options are non-standard, non-returnable

View complete specifications at: samtec.com?SEAF8-RA

LPARRAY™

LOW-PROFILE OPEN-PIN-FIELD ARRAYS

(1.27 mm) .050" PITCH



FEATURES & BENEFITS

- 4 mm, 4.5 mm, 5 mm stack heights
- Up to 400 I/Os
- 4, 6 and 8 row designs
- .050" (1.27 mm) pitch
- Dual beam contact system
- Solder crimp termination for ease of processing
- Board stacking standoffs available to assist unmating and reduce risk for component damage on board



LPAM Series; 120 pins
(actual size shown)

MAXIMUM GROUNDING & ROUTING FLEXIBILITY

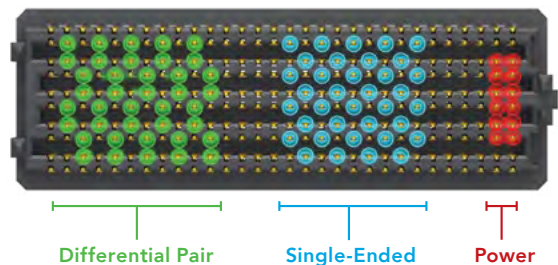

KEY SPECIFICATIONS

PITCH	TOTAL PINS	INSULATOR MATERIAL	CONTACT MATERIAL	PLATING	CURRENT RATING	WORKING VOLTAGE	LEAD-FREE SOLDERABLE
1.27 mm x 1.27 mm	Up to 400 I/Os	Black LCP	Copper Alloy	Au or Sn over 50 μ" (1.27 μm) Ni	2.2 A per pin (8 adjacent pins powered)	250 VAC	YES

(1.27 mm) .050" PITCH • LOW-PROFILE OPEN-PIN-FIELD ARRAYS

SERIES	NO. PINS PER ROW	LEAD STYLE	PLATING OPTION	NO. OF ROWS	SOLDER TYPE	K	"X"R
LPAM Terminal	-10, -20, -30, -40,	-01.0 = (1.0 mm) .039" (LPAM only)	-L = 10 μ" (0.25 μm) Gold on contact area, Matte Tin on solder tail	-04 -06 -08	-1 = Tin/Lead Alloy Solder Crimp		-K = Polyimide film Pick & Place Pad
LPAF Socket	-50 (-08 rows only)	-01.5 = (1.5 mm) .060" (LPAM only)	-S = 30 μ" (0.76 μm) Gold on contact area, Matt Tin on solder tail		-2 = Lead-Free Solder Crimp		-TR =Tape & Reel
		-03.0 = (3.0 mm) .118" (LPAF only)					-FR =Full Reel Tape & Reel (must order max. quantity per reel; contact Samtec for quantity breaks)
		-03.5 = (3.5 mm) .138" (LPAF only)					

LPAM

Board Mates:

LPAF

Standoffs:

JSO, SO

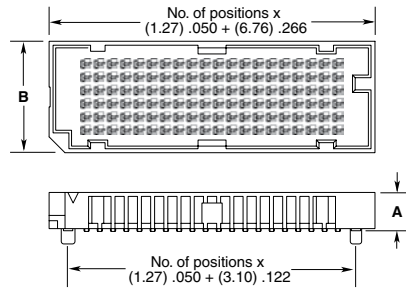
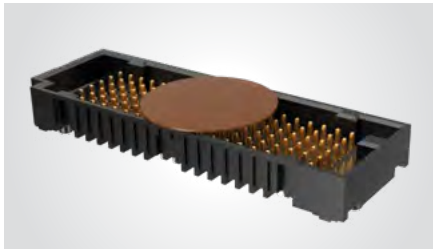

NO. OF ROWS	B
-04	(8.18) .322
-06	(10.72) .422
-08	(13.26) .522

LEAD STYLE	A
-01.0	(3.68) .145
-01.5	(4.19) .165

View complete specifications at: samtec.com?LPAM

LPAF

Board Mates:

LPAM

Standoffs:

JSO, SO

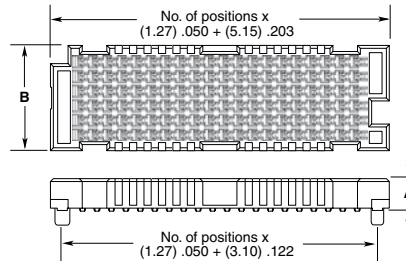
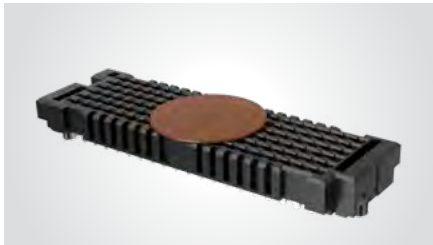

NO. OF ROWS	B
-04	(6.71) .264
-06	(9.25) .364
-08	(11.79) .464

LEAD STYLE	A
-03.0	(2.79) .110
-03.5	(3.30) .130

MATED HEIGHTS*

LPAM LEAD STYLE	LPAF LEAD STYLE	
	-03.0	-03.5
-01.0	(4.00) .157	(4.50) .177
-01.5	(4.50) .177	(5.00) .197

*Processing conditions will affect mated height.

Notes:

Some sizes, styles and options are non-standard, non-returnable

View complete specifications at: samtec.com?LPAF

JACK SCREW STANDOFF

JSO SERIES



SPECIFICATIONS

Material:
Stainless Steel
Locking Compound:
Nylon

JSO

**BOARD
STACKER**

LEAD STYLE

**PLATING
OPTION**

Specify
BOARD STACKER
from chart

-01
= Press-In
(-0415, -0515, -0715, -0815 only)

-03
= Male Thread
(-0815, -1015, -1115, -1615 only)

-L
= Locking compound
(Not available with -01 lead style,
Required for -03 lead style)

BOARD STACKER	A	B	BOARD STACK HEIGHT
-0415	(4.15) .163	(2.50) .098	4 mm
-0515	(5.15) .203	(3.50) .138	5 mm
-0715	(7.15) .281	(5.50) .217	7 mm
-0815	(8.15) .321	(6.50) .256	8 mm
-1015	(10.15) .400	(8.50) .335	10 mm
-1115	(11.15) .439	(9.50) .374	11 mm
-1615	(16.15) .636	(14.50) .571	16 mm

ALSO AVAILABLE

MOQ Required

Other heights
Locking compound removed

Notes:
Standoffs are designed,
0.15 mm longer than
connector stack heights to
allow for processing variables.

Some sizes, styles and
options are non-standard,
non-returnable.

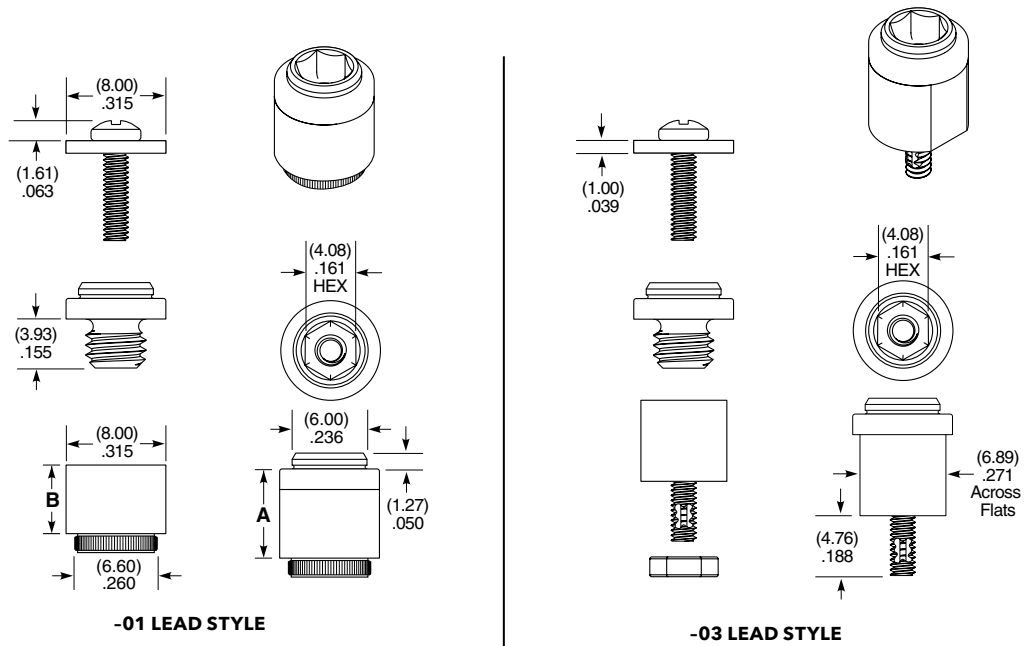

-01 LEAD STYLE

-03 LEAD STYLE

Components are to be packaged in separate bags unassembled.

APPLICATION

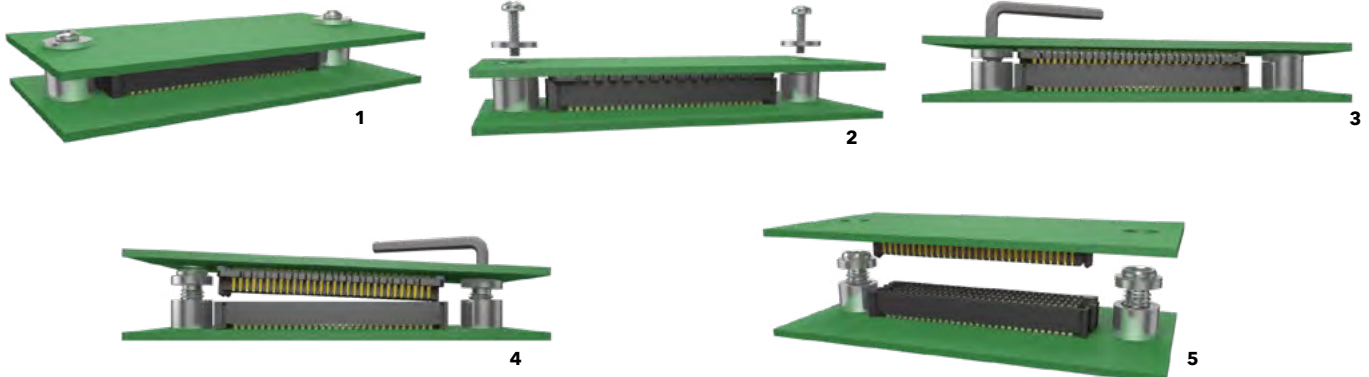

HIGH-SPEED COMPRESSION INTERPOSERS

HIGH DENSITY • ULTRA-LOW PROFILE • HIGHLY CUSTOMIZABLE

32-33

0.80 mm PITCH Z-RAY® HIGH-SPEED
COMPRESSION INTERPOSERS (ZA8, ZA8H)

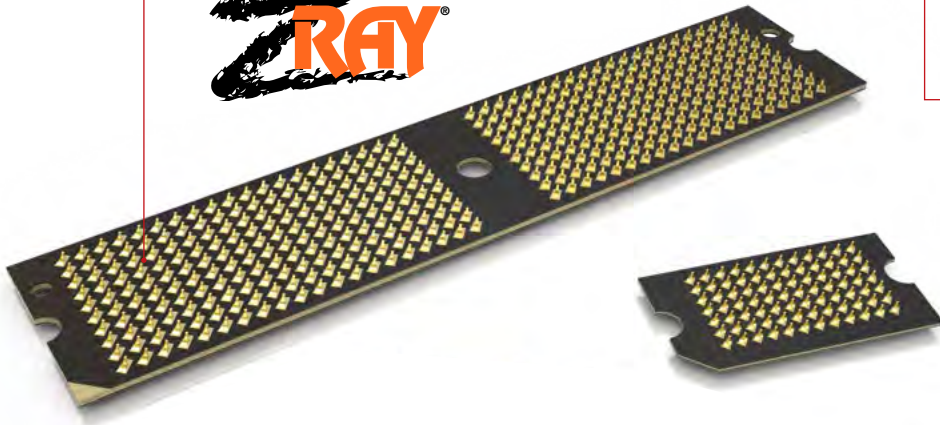

34

1.00 mm PITCH Z-RAY® HIGH-SPEED
COMPRESSION INTERPOSERS (ZA1)



35

Z-RAY® COMPRESSION HARDWARE
(ZD, ZSO, ZHSI)

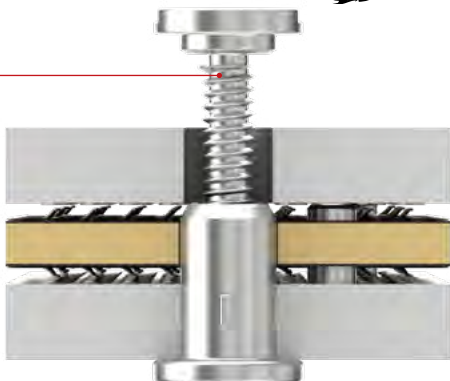

36

1.00 mm PITCH LOW-PROFILE
COMPRESSION INTERPOSERS (GMI)

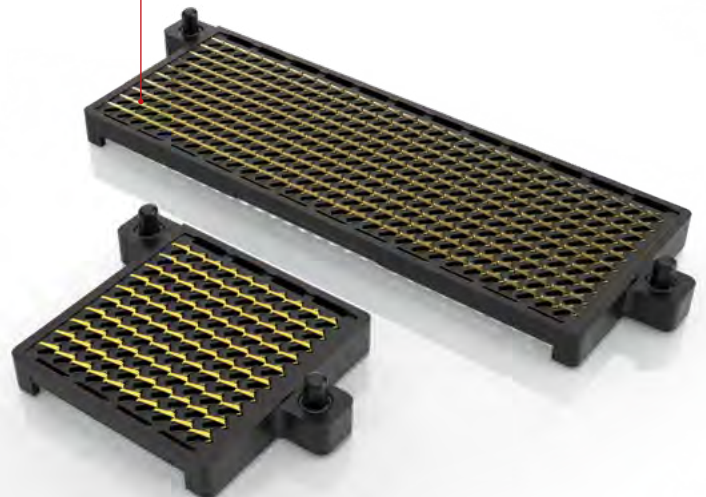



HIGH-SPEED COMPRESSION INTERPOSER

(0.80 mm) .0315" AND (1.00 mm) .0394" PITCH

FEATURES & BENEFITS

- Dual compression contacts or single compression with solder balls
- BeCu Micro-formed contacts
- Performance up to 14 Gbps (ZAX Series) and 56 Gbps (ZA8H Series)
- Low-profile body height for a short signal path
- Highly customizable solutions
- Visit samtec.com?ZRDP for ultra-low profile Z-Ray® cable assembly

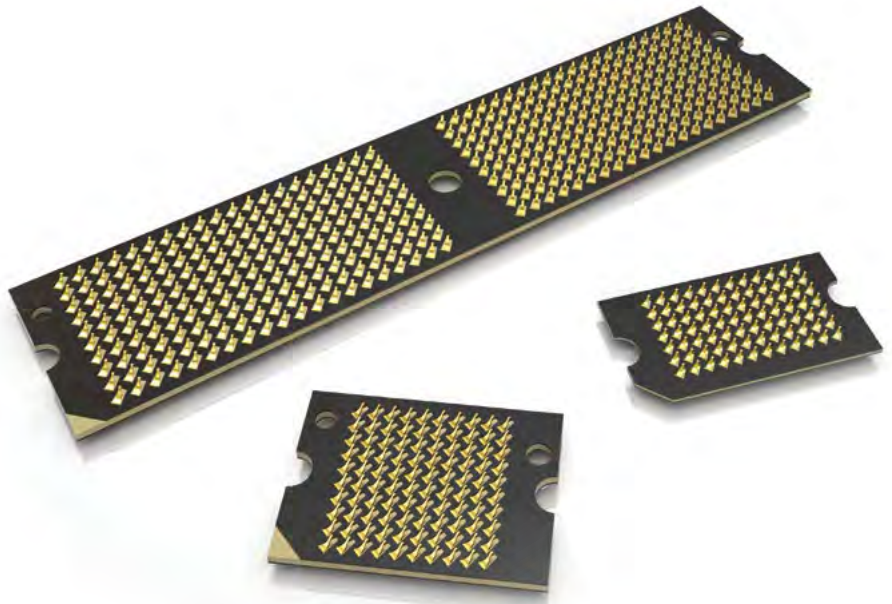

Solder Ball Option

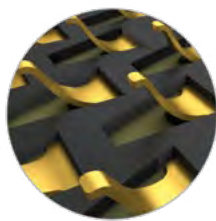

BeCu Compression Contacts

Design & Construction

- One-piece design assembled into rugged low profile FR4 substrate under high pressure and temperature
- Built standard with a 1 mm board-to-board thickness
- Contacts are designed using BeCu foils that have been formed into the "beam" structure

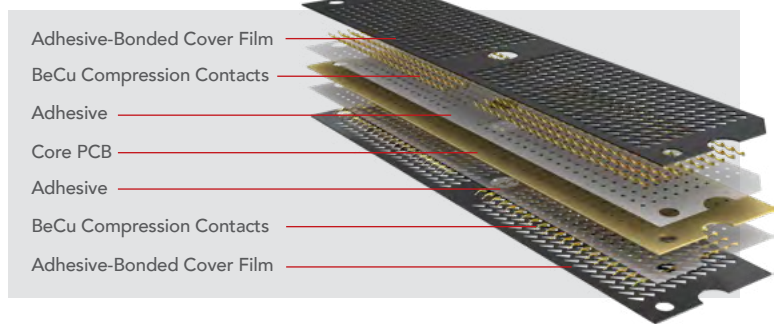

PERFORMANCE SPECIFICATIONS

		Single Compression w/ Solder Balls		Dual Compression		
Series		ZA8	ZA1	ZA8	ZA1	ZA8H
Pitch		0.80 mm	1.00 mm	0.80 mm	1.00 mm	0.80 mm
Max Row		25	20	50	58	50
Max Column		25	20	50	58	50
Thickness	Kapton Core	N/A	N/A	0.33 mm	0.33 mm	0.33 mm
	FR4 Core	1.00 to 3 mm	1.00 to 3 mm	0.5 to 3 mm	0.5 to 3 mm	N/A
Thickness Tolerance	Kapton Core	N/A	N/A	±5%	±5%	±5%
	FR4 Core	±10%	±10%	±10%	±10%	N/A
Deflection / Normal Force per Pin		0.20 mm / 30g				
Operating Temperature		-55°C to +105°C (Single Cycle only above 85°C)				

(0.80 mm) .0315" PITCH • HIGH-SPEED COMPRESSION INTERPOSER

ZA8	POSITIONS PER ROW	TERMINATION	HEIGHT	PLATING OPTION	NO. OF ROWS	SOLDER TYPE
	-10, -20, -30, -40	-1 = Single Compression with Solder Balls (-10 & -20 positions only) -2 = Dual Compression (-10, -20, -30 & -40 positions only)	-1.00 = (1.00 mm) .040" Height	-Z = 6 μ" (0.15 μm) Gold in contact area	-10 = Ten Rows	(Termination -1 only) -1 = Lead -2 = Lead-Free

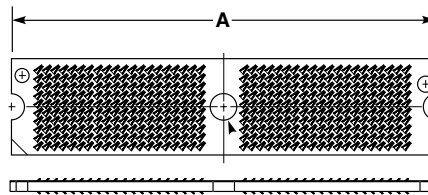
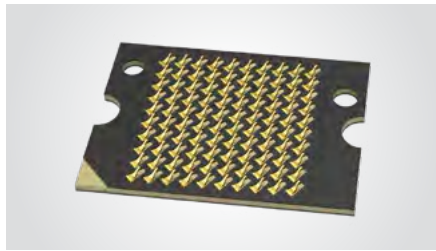

POSITIONS PER ROW	A	B
-10	(12.50) .492	(9.35) .368
-20	(20.50) .807	(17.35) .683
-30	(31.70) 1.248	N/A
-40	(39.70) 1.563	N/A

40 X 20 DUAL COMPRESSION

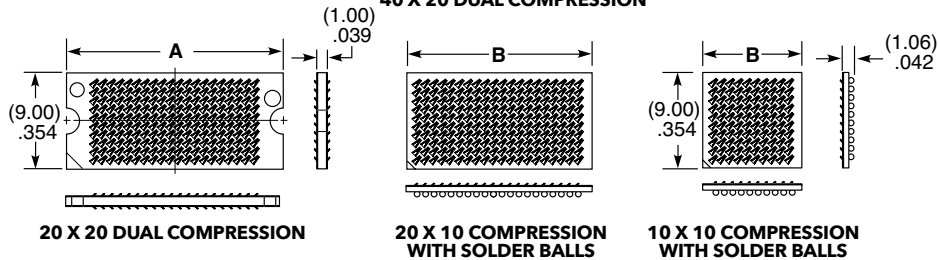

NRZ
14
Gbps

View complete specifications at: samtec.com?ZA8

ZA8H	NO. OF POSITIONS	HEIGHT	PLATING OPTION	NO. OF ROWS
	-06, -12, -24 (See Chart Below For Number of Pairs)	-0.33 = (0.33 mm) .013" Height	-Z = 6 μ" (0.15 μm) Gold in contact over 40 μ" to 100 μ" (1.02 μm - 2.54 μm) Nickel	-04 = Four Rows -07 = Seven Rows

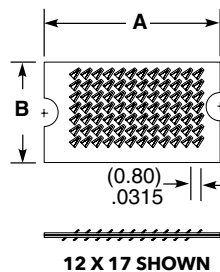
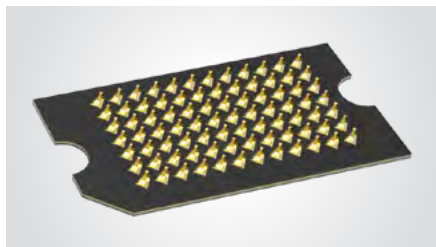

NO. OF POSITIONS	A
-06	(7.80) .307
-12	(12.60) .496
-24	(22.20) .874

NO. OF ROWS	B
-04	(4.70) .185
-07	(7.10) .280

NRZ
56
Gbps

12 X 17 SHOWN

View complete specifications at: samtec.com?ZA8H

Notes:
Some sizes, styles and options are non-standard, non-returnable

ZA1	POSITIONS PER ROW	TERMINATION	HEIGHT	PLATING OPTION	NO. OF ROWS	SOLDER TYPE
	-10, -20, -30, -40	<p>-1 = Single Compression with Solder Balls (-10 & -20 positions only)</p> <p>-2 = Dual Compression (-10, -20, -30 & -40 positions only)</p>	<p>-1.00 = (1.00 mm) .040" Height</p>	<p>-Z = 6 μ" (0.15 μm) Gold in contact area</p>	<p>-10 = Ten Rows</p>	<p>(Termination -1 only)</p> <p>-1 = Lead</p> <p>-2 = Lead-Free</p>

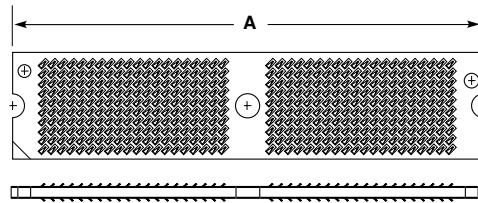
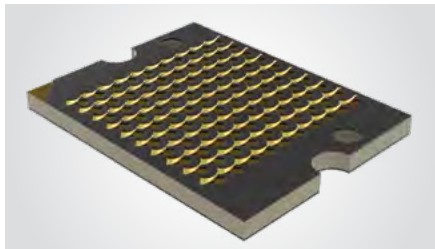

40 X 10 DUAL COMPRESSION

POSITIONS PER ROW	A	B
-10	(14.30) .563	(11.40) .449
-20	(24.30) .957	(21.40) .843
-30	(38.30) 1.508	N/A
-40	(48.30) 1.902	N/A

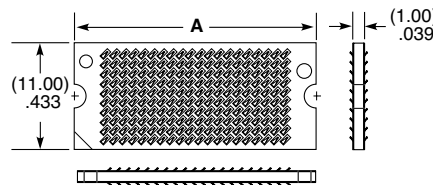
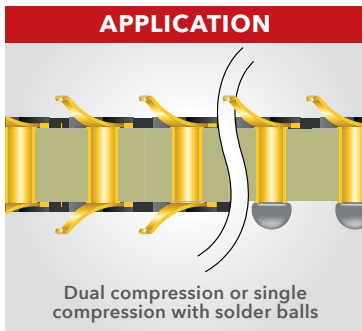

20 X 10 DUAL COMPRESSION

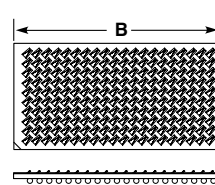

20 X 10 COMPRESSION WITH SOLDER BALLS

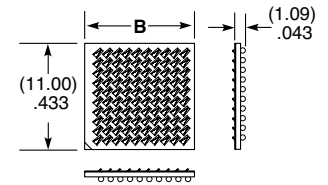

10 X 10 COMPRESSION WITH SOLDER BALLS

View complete specifications at: samtec.com?ZA1

Ultimate Design Flexibility

- Configurations for any application, complete with detailed footprints
- Customer-specific stack heights, pin counts, insulator shapes and plating thicknesses
- Customizable in X-Y-Z axes
- Quick-turn customization with minimal NRE and tooling charges
- Various compression and alignment configurations

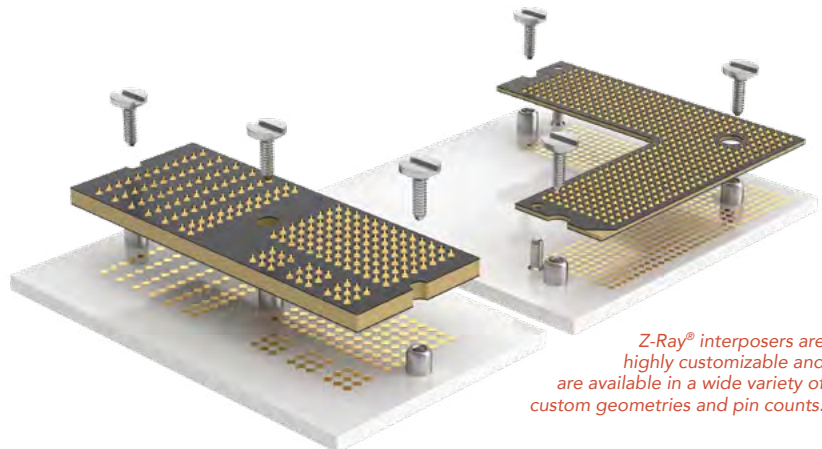

Z-Ray® interposers are highly customizable and are available in a wide variety of custom geometries and pin counts.

PRESS-FIT ALIGNMENT HARDWARE

ZSO

STACK HEIGHT

01

-0100
= 1.00 mm (.0394")

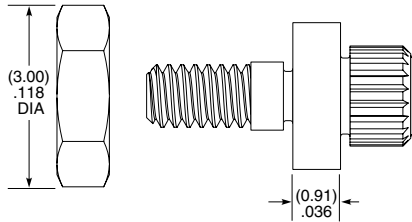
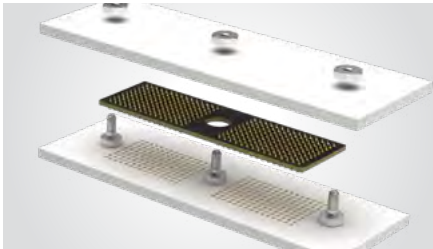

View complete specifications at: samtec.com?ZSO

ZD

DIAMETER

LENGTH

-1.00
= 1.00 mm (.0394")

-03.7
= 03.7 mm (.146")

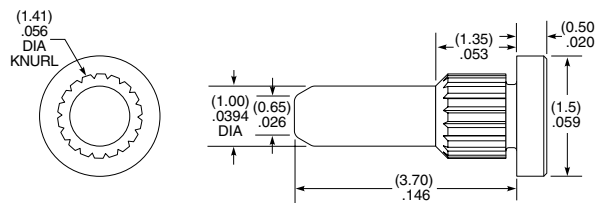
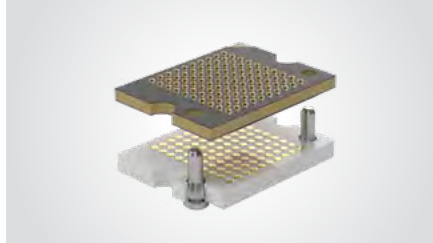

View complete specifications at: samtec.com?ZD

ZHSI

STACK HEIGHT

HEAD SPECIFICATION

Specify STACK HEIGHT from chart below

-01
= Slot Head

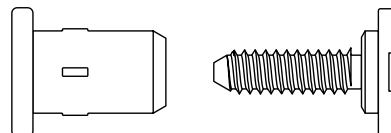
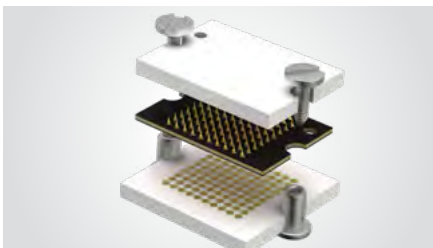

STACK HEIGHT	PCB 1 THICKNESS	PCB 2 THICKNESS	INTERPOSER HEIGHT
-01	(1.57) 0.062	(1.57) 0.062	(1.00) 0.039
-02	(2.36) 0.093	(1.57) 0.062	(1.00) 0.039
-02	(2.36) 0.093	(2.36) 0.065	(1.00) 0.039
-02	(3.18) 0.125	(1.57) 0.062	(1.00) 0.039
-03	(3.18) 0.125	(2.36) 0.093	(1.00) 0.039

Notes:

Some sizes, styles and options are non-standard, non-returnable

View complete specifications at: samtec.com?ZHSI

PAM 4

56
G b p s

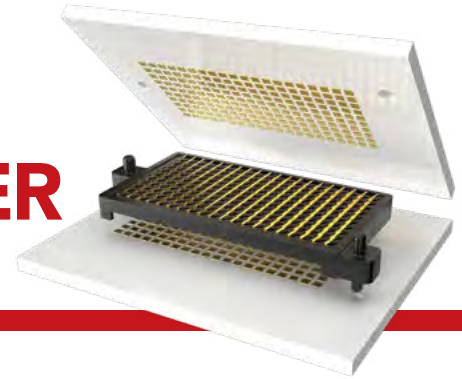

LOW-PROFILE COMPRESSION INTERPOSER

(1.00 mm) .0394" PITCH • GMI SERIES

SPECIFICATIONS

Insulator Material:
Black LCP
Contact Material:
Copper Alloy
Plating:
Au or 50 μ" (1.27 μm) Ni
Current Rating:
.89 A per pin
(10 pins powered)

GMI

**POSITIONS
PER ROW**

-10, -20, -30

STYLE

-2
= Dual
Compression

**BOARD
SPACING**

-1.27
= (1.27 mm) .050"
Board Space

**PLATING
OPTION**

-G
= 10 μ"
(0.25 μm)
Gold on
contact area

ROWS

-10
= Ten Rows

PROCESSING

Lead-Free Solderable:
Yes
SMT Lead Complanarity:
(0.05 mm) .002" (10-20)*
(0.08 mm) .003" (30)*
*(.004" stencil solution
may be available;
contact ipg@samtec.com)

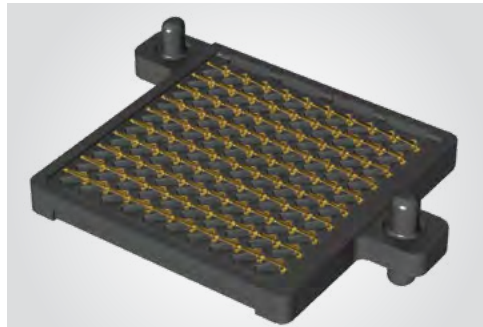

GMI Series is an ideal low-cost solution
for board stacking, module-to-board or
LGA interface

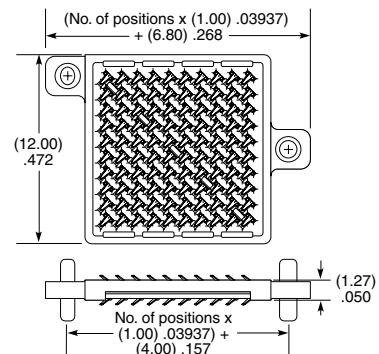

10 X 10

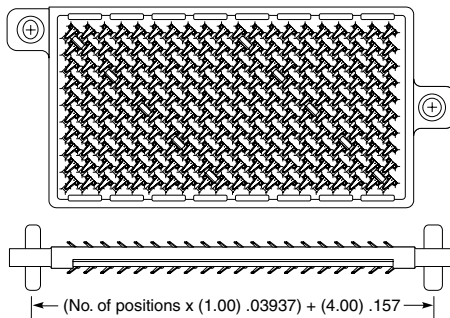

20 X 10

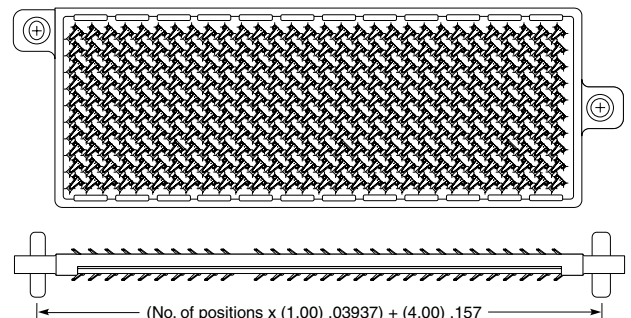

30 X 10

Notes:
Some lengths, styles and options
are non-standard, non-returnable

HIGH-SPEED MEZZANINE SYSTEMS

25+ Gbps PERFORMANCE • INTEGRAL GROUND PLANE • EDGE RATE® CONTACTS

39-41 **Q STRIP® INTEGRAL GROUND PLANE INTERCONNECTS**
 0.50 mm (.0197") Pitch (QTH, QSH)
 0.80 mm (.0315") Pitch (QTE, QSE)
 0.635 mm (.025") Pitch (QTS, QSS)



42-43 **Q2™ RUGGED INTEGRAL GROUND PLANE INTERCONNECTS**
 0.635 mm (.025") Pitch (QMS, QFS)
 0.635 mm (.025") Pitch Shielded (QMSS, QFSS)

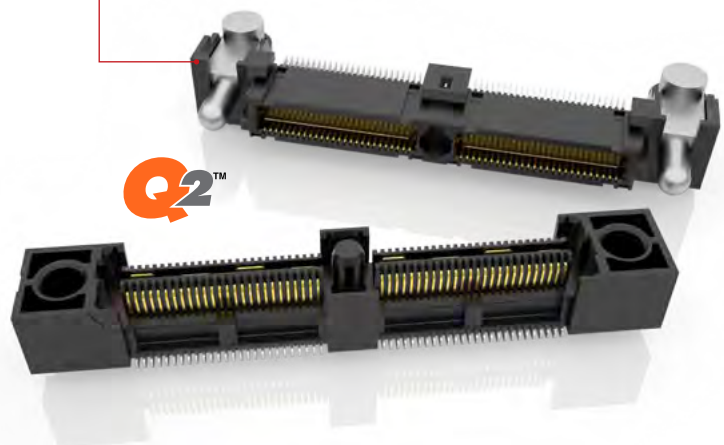

44 **Q RATE® SLIM BODY INTEGRAL GROUND PLANE INTERCONNECTS**
 0.80 mm (.0315") Pitch (QRM8, QRF8)

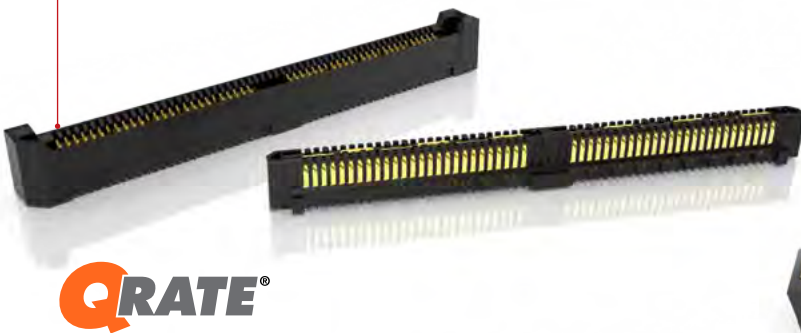

49-54 **EDGE RATE® RUGGED HIGH-SPEED INTERCONNECTS**
 0.50 mm (.0197") Pitch (ERM5, ERF5)
 0.635 mm (.025") Pitch (ERM6, ERF6)
 0.80 mm (.0315") Pitch (ERM8, ERF8)

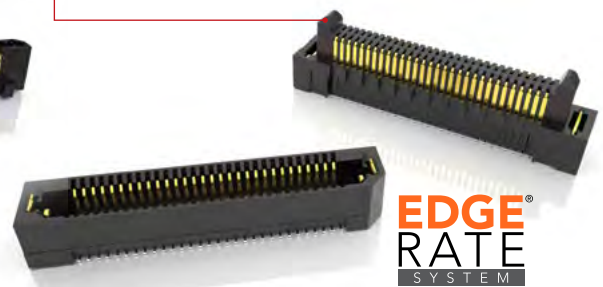



HIGH-SPEED GROUND PLANE MEZZANINE CONNECTORS



NRZ
25
Gbps

NRZ
28
Gbps



FEATURES & BENEFITS

- Designed for high-speed board-to-board applications where signal integrity is essential
- Q Strip® low-profile connectors on 0.50 mm, 0.635 mm and 0.80 mm pitches
- Q Rate® slim connectors with Edge Rate® contacts on 0.80 mm pitch with a 1.20 mm contact wipe
- Q2™ rugged connectors on 0.635 mm pitch with increased insertion depth for rugged applications
- Right-angle, edge mount, EMI shielding, power and RF options
- Differential pair and single-ended routing



Differential Pairs
Reduce Noise

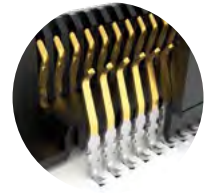

Rugged Edge Rate®
Contact System



Power, Retention
& RF Options



Precision Board
Stacking Standoffs

INTEGRAL GROUND / POWER PLANE

- Surface mount ground plane between two signal rows improves electrical performance
- Significantly reduces row-to-row crosstalk
- Integral metal plane for power to 25 Amps





(0.50 mm) .0197" PITCH • QTH/QSH SERIES

QTH
Board Mates:
QSH

QSH
Board Mates:
QTH

QTH/QSH
Cable Mates:
HQCD, HQDP

Standoffs:
SO

QTH	PINS PER ROW NO. OF PAIRS	LEAD STYLE	PLATING OPTION	TYPE	A	OTHER OPTIONS
-----	---------------------------	------------	----------------	------	---	---------------

-030, -060, -090
(60 total pins per bank = -D)

-020, -040, -060
(20 pairs per bank = -D-DP)

Specify LEAD STYLE from chart

-F
= Gold flash on contact, Matte Tin on tail

-L
= 10 μ" (0.25 μm) Gold on contact, Matte Tin on tail

-C
= 50 μ" (1.27 mm) Electro-Polished Selective Gold on contact, Matte Tin on tail (passes 10 year MFG testing)

-D
= Single-Ended

-D-DP
= Differential Pair (-01 only)

-K
= (7.00 mm) .275" DIA Polyimide film Pick & Place Pad (N/A with -05 & -07 lead style)

-L
= Latching Option (-01 lead style only) (N/A on -060 (-D-DP) & -090)

-TR
= Tape & Reel

-FR
= Full Reel Tape & Reel (must order max. quantity per reel; contact Samtec for quantity breaks)

SPECIFICATIONS

Insulator Material: Liquid Crystal Polymer
Contact Material: Phosphor Bronze
Plating: Au or Sn over 50 μ" (1.27 μm) Ni
Current Rating: Contact: 2 A per pin (2 pins powered) Ground Plane: 25 A per ground plane (1 ground plane powered)
Operating Temp Range: -55 °C to +125 °C
Voltage Rating: 175 VAC (5 mm Stack Height)
Max Cycles: 100

QTH LEAD STYLE	A	HEIGHT WITH QSH*
-01	(4.27) .168	(5.00) .197
-02	(7.26) .286	(8.00) .315
-03	(10.27) .404	(11.00) .433
-04	(15.25) .600	(16.00) .630
-05	(18.26) .718	(19.00) .748
-07	(24.24) .954	(25.00) .984
-09	(13.26) .522	(14.00) .551

*Processing conditions will affect mated height. See SO Series for board space tolerances.

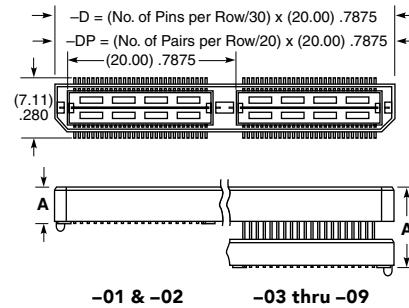

PROCESSING

Lead-Free Solderable: Yes
SMT Lead Coplanarity: (0.10 mm) .004" max (030-060) (0.15 mm) .006" max (090)*
*(.004" stencil solution may be available; contact IPG@samtec.com)
Board Stacking: For applications requiring more than two connectors contact ipg@samtec.com

STANDARDS

PISMO™ 1: Visit samtec.com/standards for more information.



Note: Some lengths, styles and options are non-standard, non-returnable.

View complete specifications at: samtec.com?QTH

QSH	PINS PER ROW NO. OF PAIRS	01	PLATING OPTION	TYPE	A	OTHER OPTIONS
-----	---------------------------	----	----------------	------	---	---------------

-030, -060, -090
(60 total pins per bank = -D)

-020, -040, -060
(20 pairs per bank = -D-DP)

-F
= Gold flash on contact, Matte Tin on tail

-L
= 10 μ" (0.25 μm) Gold on contact, Matte Tin on tail

-C
= 50 μ" (1.27 mm) Electro-Polished Selective Gold on contact, Matte Tin on tail (passes 10 year MFG testing)

-D
= Single-Ended

-D-DP
= Differential Pair (-01 only)

-K
= (8.25 mm) .325" DIA Polyimide film Pick & Place Pad

-L
= Latching Option (-01 lead style only) (N/A on -060 (-D-DP) & -090)

-TR
= Tape & Reel

-FR
= Full Reel Tape & Reel (must order max. quantity per reel; contact Samtec for quantity breaks)

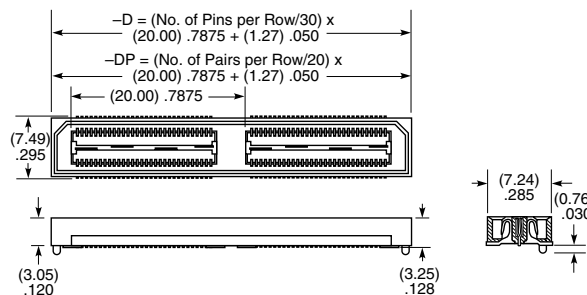

View complete specifications at: samtec.com?QSH

See pg 46-47 for Right-Angle & Edge Mount options.



QTE
Board Mates:
QSE

QSE
Board Mates:
QTE

QTE/QSE
Cable Mates:
EQCD, EQDP
Standoffs:
SO

QTE	PINS PER ROW NO. OF PAIRS	LEAD STYLE	PLATING OPTION	TYPE	A	OTHER OPTIONS
	-020, -040, -060 (40 total pins per bank = -D)	Specify LEAD STYLE from Chart	-F = Gold flash on contact, Matte Tin on tail	-D = Single-Ended		-K = (7.00 mm) .275" DIA Polyimide film Pick & Place Pad
	-014, -028, -042 (14 pairs per bank = -D-DP)		-L = 10 μ" (0.25 μm) Gold on contact, Matte Tin on tail	-D-DP = Differential Pair (-01 only)		-L = Latching Option (N/A on -042 & -060 positions)
			-C = 50 μ" (1.27 mm) Electro-Polished Selective Gold on contact, Matte Tin on tail (passes 10 year MFG testing)			-TR = Tape & Reel (N/A -05 & -07 Lead Style)

SPECIFICATIONS

Insulator Material: Liquid Crystal Polymer
Contact Material: Phosphor Bronze
Plating: Au or Sn over 50 μ" (1.27 μm) Ni
Current Rating: Contact: 2 A per pin (2 pins powered)
Ground Plane: 23 A per ground plane (1 ground plane powered)
Operating Temp Range: -55 °C to +125 °C
Voltage Rating: 225 VAC when mated & 5 mm Stack Height
Max Cycles: 100

QTE LEAD STYLE	A	HEIGHT WITH QSE*
-01	(4.27) .168	(5.00) .197
-02	(7.26) .286	(8.00) .315
-03	(10.27) .404	(11.00) .433
-04	(15.25) .600	(16.00) .630
-05	(18.26) .718	(19.00) .748
-07	(24.24) .954	(25.00) .984
-09	(13.26) .522	(14.00) .551

*Processing conditions will affect mated height. See SO Series for board space tolerances.

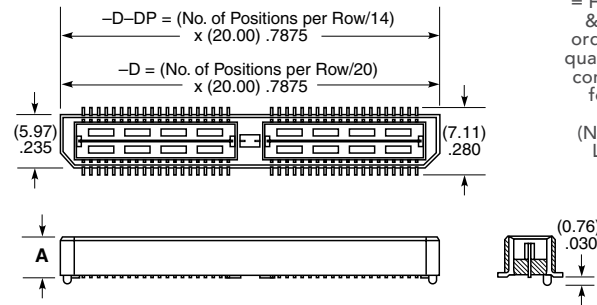

View complete specifications at: samtec.com?QTE

PROCESSING

Lead-Free Solderable: Yes
SMT Lead Coplanarity: (0.10 mm) .004" max (020-060)
Board Stacking: For applications requiring more than two connectors contact ipg@samtec.com



QSE	PINS PER ROW NO. OF PAIRS	01	PLATING OPTION	TYPE	A	OTHER OPTIONS
	-020, -040, -060 (40 total pins per bank = -D)		-F = Gold flash on contact, Matte Tin on tail	-D = Single-Ended		-GP = Guide Post (-020 only)
	-014, -028, -042 (14 pairs per bank = -D-DP)		-L = 10 μ" (0.25 μm) Gold on contact, Matte Tin on tail	-D-DP = Differential Pair (-01 only)		-K = (8.25 mm) .325" DIA Polyimide Film Pick & Place Pad
			-C = 50 μ" (1.27 mm) Electro-Polished Selective Gold on contact, Matte Tin on tail (passes 10 year MFG testing)			-L = Latching Option (N/A on -042 & -060 positions)

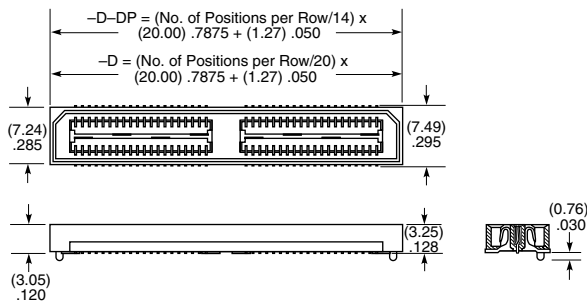

Note: Some lengths, styles and options are non-standard, non-returnable.

View complete specifications at: samtec.com?QSE



(0.635 mm) .025" PITCH • QTS/QSS SERIES

QTS
Board Mates:
QSS

QSS
Board Mates:
QTS

QTS/QSS
Cable Mates:
SQCD

Standoffs:
SO



QTS	NO. OF POSITIONS PER ROW	LEAD STYLE	PLATING OPTION	D	A	OTHER OPTIONS
	-025, -050, -075 (50 total positions per bank)	Specify LEAD STYLE from Chart	-F = Gold flash on contact, Matte Tin on tail -L = 10 μm (0.25 μm) Gold on contact, Matte Tin on tail -C = 50 μm (1.27 mm) Electro-Polished Selective Gold on contact, Matte Tin on tail (passes 10 year MFG testing)			-K = (7.00 mm) .275" DIA Polyimide film Pick & Place Pad -TR = Tape & Reel -FR = Full Reel Tape & Reel (must order maximum quantity per reel; contact Samtec for quantity breaks)

SPECIFICATIONS

Insulator Material:
Liquid Crystal Polymer
Contact Material:
Phosphor Bronze
Plating:
Au or Sn over 50 μm (1.27 μm) Ni
Current Rating:
Contact:
1.8 A per pin (2 pins powered)
Ground Plane:
23.1 A per ground plane (1 ground plane powered)
Operating Temp Range:
-55 °C to +125 °C
Voltage Rating:
285 VAC
Max Cycles:
100

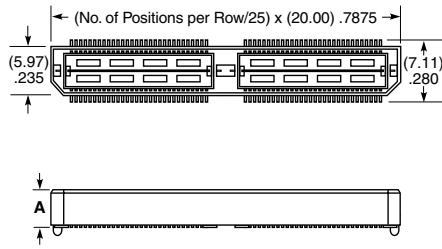

QTS LEAD STYLE	A	MATED HEIGHT WITH QSS
-01	(4.27) .168	(5.00) .197
-02	(7.26) .286	(8.00) .315

*Processing conditions will affect mated height. See SO Series for board space tolerances.

View complete specifications at: samtec.com?QTS

PROCESSING

Lead-Free Solderable:
Yes
QTS SMT Lead Coplanarity:
(0.10 mm) .004" max (025-075)
QSS SMT Lead Coplanarity:
(0.10 mm) .004" max (025-050)
(0.15 mm) .006" max (075)*
*(.004" stencil solution may be available; contact ipg@samtec.com)
Board Stacking:
For applications requiring more than two connectors contact ipg@samtec.com



QSS	NO. OF POSITIONS PER ROW	01	PLATING OPTION	D	A	OTHER OPTIONS
	-025, -050, -075 (50 total positions per bank)		-F = Gold flash on contact, Matte Tin on tail -L = 10 μm (0.25 μm) Gold on contact, Matte Tin on tail -C = 50 μm (1.27 mm) Electro-Polished Selective Gold on contact, Matte Tin on tail (passes 10 year MFG testing)			-GP = Guide Holes for mating with QTS-RA -K = (8.25 mm) .325" DIA Polyimide Film Pick & Place Pad -TR = Tape & Reel -FR = Full Reel Tape & Reel (must order maximum quantity per reel; contact Samtec for quantity breaks)

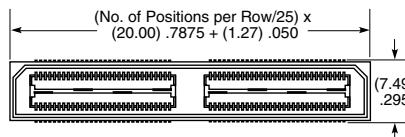
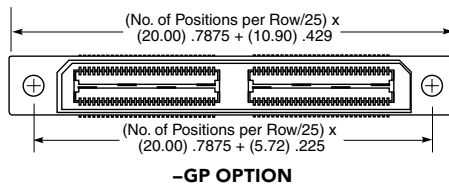

See pg 46-47 for Right-Angle & Edge Mount options.

View complete specifications at: samtec.com?QSS



Note:
Some lengths, styles and options are non-standard, non-returnable.



NRZ
25
Gbps

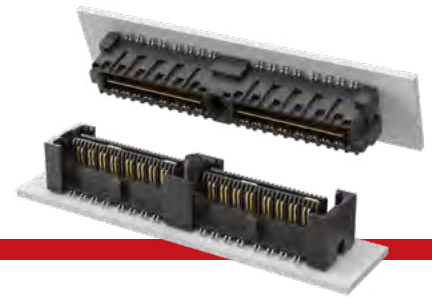

(0.635 mm) .025" PITCH • QMS/QFS SERIES

QMS
Board Mates:
QFS

QFS
Board Mates:
QMS

QMS/QFS
Cable Mates:
6QCD

Standoffs:
SO, JSOM

QMS	PINS PER ROW NO. OF PAIRS	LEAD STYLE	PLATING OPTION	TYPE	A	OTHER OPTION
-----	---------------------------	------------	----------------	------	---	--------------

	-026, -052, -078 (52 total pins per bank = -D)	Specify LEAD STYLE from Chart	-L = 10 μm (0.25 μm) gold on contact, Matte Tin on tail (-05.75 & -06.75 Lead Style Only)	-D = Single-Ended		-K = (5.50 mm) .217" DIA Polyimide film Pick & Place Pad
	-016, -032, -048 (16 pairs per bank = -D-DP)		-SL = 10 μm (0.25 μm) gold on contact, Matte Tin on tail (-09.75 Lead Style Only)	-D-DP = Differential Pair		
	(-078 & -048 N/A with -09.75 Lead Style)					

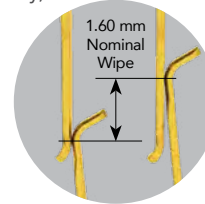

PACKAGING OPTION
Tape & Reel Options (-TR & -FR) available. Visit series web page and view engineering prints for complete specifications.

MATED HEIGHT*			
QMS LEAD STYLE	A	QFS LEAD STYLE	
		-4.25	-6.25
-05.75	(5.38) .212	10 mm	12 mm
-06.75	(6.35) .250	11 mm	13 mm
-09.75	(9.35) .368	14 mm	16 mm

*Processing conditions will affect mated height. See SO Series for board space tolerances.

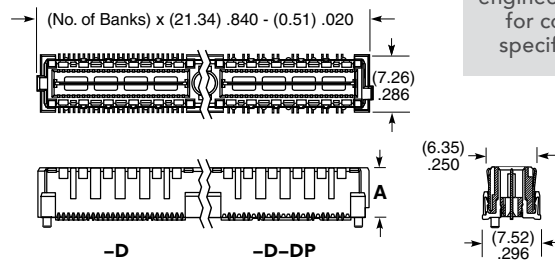

SPECIFICATIONS

Insulator Material: Liquid Crystal Polymer
Contact & Ground Plane Material: Phosphor Bronze
Plating: Au over 50 μm (1.27 μm) Ni (Tin on Ground Plane Tail)
Current Rating: Contact: 2.6 A per pin (2 pins powered)
Ground Plane: 15.7 A per ground plane (1 ground plane powered)
Operating Temp Range: -55 °C to +125 °C
Voltage Rating: 300 VAC when mated

PROCESSING

Lead-Free Solderable: Yes
QMS SMT Lead Coplanarity: (0.10 mm) .004" max (026-052) (0.15 mm) .006" max (078)*
*(.004" stencil solution may be available; contact IPG@samtec.com)
QFS SMT Lead Coplanarity: (0.10 mm) .004" max (026-078)
Board Stacking: For applications requiring more than two connectors contact ipg@samtec.com

STANDARDS

SUMIT™
PCI/104-Express™
PCI/104-Express™ OneBank
Visit samtec.com/standards for more information, including mated heights and complete part numbers.

View complete specifications at: samtec.com?QMS

QFS	PINS PER ROW NO. OF PAIRS	LEAD STYLE	PLATING OPTION	TYPE	A	OTHER OPTION
-----	---------------------------	------------	----------------	------	---	--------------

	-026, -052, -078 (52 total pins per bank = -D)	Specify LEAD STYLE from Chart	-L = 10 μm (0.25 μm) gold on contact, Matte Tin on tail (-04.25 Lead Style only)	-D = Single-Ended		-GP = Guide Holes (-04.25 Lead Style only)
	-016, -032, -048 (16 pairs per bank = -D-DP)		-SL = 10 μm (0.25 μm) gold on contact, Matte Tin on tail (-06.25 Lead Style only)	-D-DP = Differential Pair (-04.25 Lead Style only)		

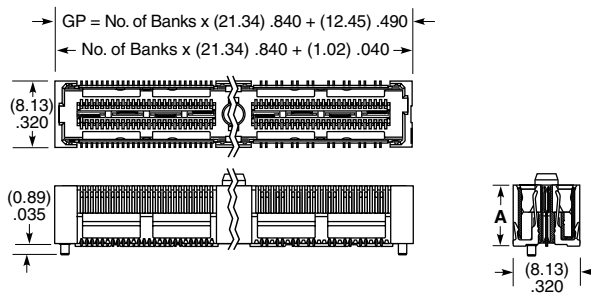

LEAD STYLE	A
-04.25	(7.44) .299
-06.25	(9.42) .371

PACKAGING OPTION
Tape & Reel Options (-TR & -FR) available. Visit series web page and view engineering prints for complete specifications.

Note: Some lengths, styles and options are non-standard, non-returnable.

View complete specifications at: samtec.com?QFS

See pg 46-47 for Right-Angle & Edge Mount options.



NRZ

14
Gbps

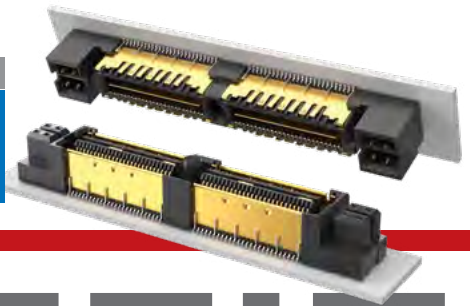

(0.635 mm) .025" PITCH • QMSS/QFSS SERIES

QMSS
Board Mates:
QFSS

QFSS
Board Mates:
QMSS

QMSS/QFSS
Standoffs:
SO

SPECIFICATIONS

Insulator Material:
Liquid Crystal Polymer
Terminal, Ground Plane & Shield Material:
Phosphor Bronze
Plating:
Au over 50 μ" (1.27 μm) Ni (Tin on Ground Plane Tail)
Operating Temp Range:
-55 °C to +125 °C
Voltage Rating:
300 VAC when mated

PROCESSING

Lead-Free Solderable:
Yes
SMT Lead Coplanarity:
(0.10 mm) .004" max (026-078)
Board Stacking:
For applications requiring more than two connectors contact ipg@samtec.com

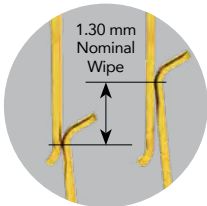

QMSS	PINS PER ROW NO. OF PAIRS	06.75	PLATING OPTION	TYPE	A	OTHER OPTION
------	---------------------------	-------	----------------	------	---	--------------

-026, -052, -078
(52 total pins per bank / 40 signals + 12 grounds to shield = -D)

-016, -032, -048
(16 pairs per bank = -D-DP)

-L
= 10 μ" (0.25 μm) gold on contact, Matte Tin on tail

-D
= Single-Ended

-D-DP
= Differential Pair

-K
= (5.50 mm) .217" DIA Polyimide film Pick & Place Pad (N/A with -PC4)

-PC4
= 4 Power Pins/End (N/A with -A)

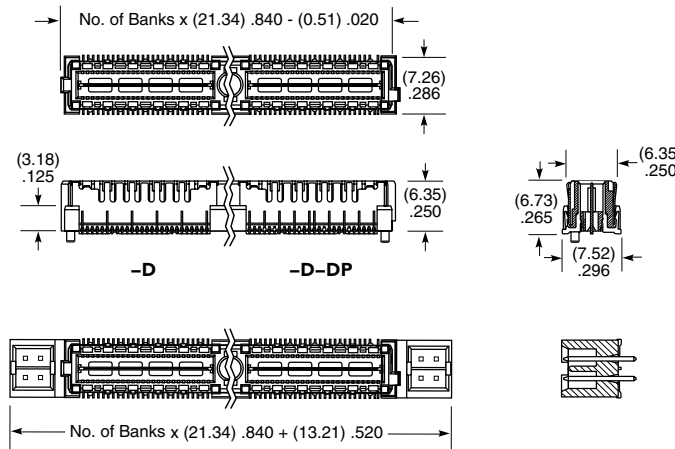

PACKAGING OPTION

Tape & Reel Options (-TR & -FR) available. Visit series web page and view engineering prints for complete specifications.

View complete specifications at: samtec.com?QMSS

QFSS	PINS PER ROW NO. OF PAIRS	04.25	PLATING OPTION	TYPE	A	OTHER OPTION
------	---------------------------	-------	----------------	------	---	--------------

-026, -052, -078
(52 total pins per bank / 40 signals + 12 grounds to shield = -D)

-016, -032, -048
(16 pairs per bank = -D-DP)

-L
= 10 μ" (0.25 μm) gold on contact, Matte Tin on tail

-D
= Single-Ended

-D-DP
= Differential Pair

-PC4
= 4 Power Pins/End (N/A with -A)

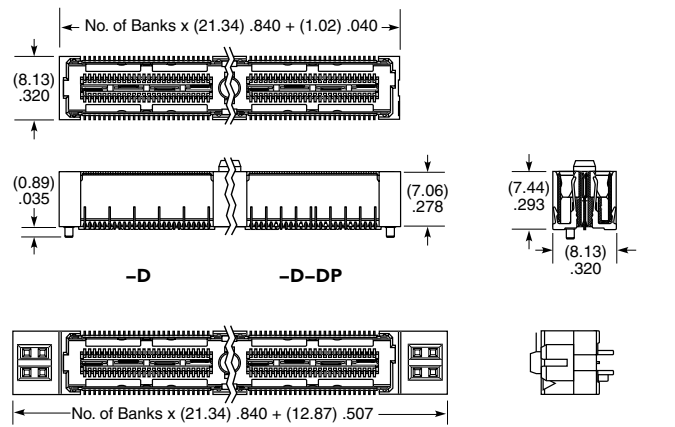

PACKAGING OPTION

Tape & Reel Options (-TR & -FR) available. Visit series web page and view engineering prints for complete specifications.

Note:
Some lengths, styles and options are non-standard, non-returnable.

View complete specifications at: samtec.com?QFSS



(0.80 mm) .0315" PITCH • QRM8/QRF8 SERIES

QRM8
Board Mates:
QRF8

QRF8
Board Mates:
QRM8

QRM8/QRF8
Cable Mates:
EQRD

SPECIFICATIONS

Insulator Material:
Black LCP
QRM8 Terminal Material:
Phosphor Bronze
QRF8 Contact Material:
BeCu
Ground Plane Material:
Phosphor Bronze
Plating:
Au or Sn over
50 μm (1.27 μm) Ni
Current Rating:
Contact:
2.2 A per pin (2 pins powered)
Ground:
8.5 A per ground plane
(1 ground plane powered)
Operating Temp Range:
-55 °C to +125 °C
Voltage Rating:
215 VAC
Max Cycles:
100

QRM8	PINS PER ROW NO. OF PINS	LEAD STYLE	PLATING OPTION	TYPE	A	OTHER OPTIONS
------	--------------------------	------------	----------------	------	---	---------------

-026, -052, -078 (52 total pins per bank = -D)	-02.0 = 2 mm Body Height (N/A -054 & -078 Positions)	-L = 10 μm (0.25 μm) Gold on contact, Matte Tin on tail	-D = Single-Ended	-GP = Guide Post		
-018, -036, -054 (18 pairs per bank = -D-DP)	-05.0 = 5 mm Body Height	-D-DP = Differential Pair		-K = (5.00 mm) .197" DIA Polyimide Film Pick & Place Pad		
	-07.0 = 7 mm Body Height			-TR = Tape & Reel (-018, -026, -036, -052 only)		
				-FR = Full Reel Tape & Reel (must order maximum quantity per reel; contact Samtec for quantity breaks) (-018, -026, -036, -052 only)		

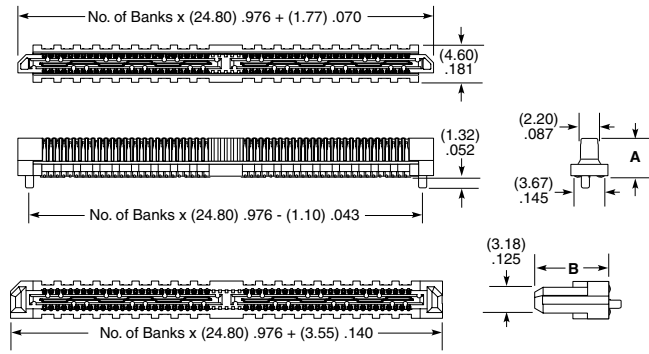

LEAD STYLE	A	B
-02	(4.81) .189	(6.12) .241
-05	(7.81) .307	(9.12) .359
-07	(9.78) .385	(11.12) .438

-GP OPTION

View complete specifications at: samtec.com?QRM8

PROCESSING

Lead-Free Solderable:
Yes
SMT Lead Coplanarity:
(0.10 mm) .004" max (-018-026)
(0.15 mm) .006" max (-036-078)*
*(.004" stencil solution may be available; contact IPG@samtec.com)
Board Stacking:
For applications requiring more than two connectors contact ipg@samtec.com

QRF8	PINS PER ROW NO. OF PAIRS	LEAD STYLE	PLATING OPTION	TYPE	A	OTHER OPTIONS
------	---------------------------	------------	----------------	------	---	---------------

-026, -052, -078 (52 total pins per bank = -D)	-05.0 = 5 mm Body Height	-L = 10 μm (0.25 μm) Gold on contact, Matte Tin on tail	-D = Single-Ended	-GP = Guide Post		
-018, -036, -054 (18 pairs per bank = -D-DP)	-07.0 = 7 mm Body Height	-D-DP = Differential Pair		-K = (5.00 mm) .197" DIA Polyimide Film Pick & Place Pad		
				-TR = Tape & Reel (-018, -026, -036, -052 only)		
				-FR = Full Reel Tape & Reel (must order max. quantity per reel; contact Samtec for quantity breaks) (-018, -026, -036, -052 only)		

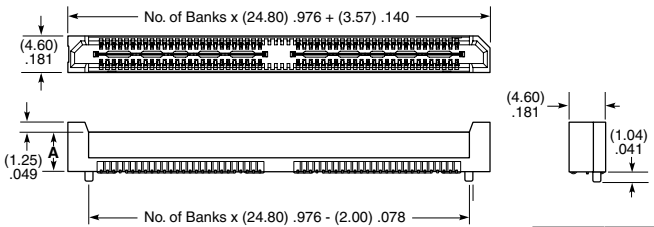

LEAD STYLE	A
-05	(5.01) .197
-07	(7.01) .276

-GP OPTION

View complete specifications at: samtec.com?QRF8

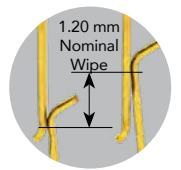

Note:
Some lengths, styles and options are non-standard, non-returnable.

MATED HEIGHT*			
QRF8 LEAD STYLE	QRM8 LEAD STYLE		
	-02.0	-05.0	-07.0
-05	(7.00) .276	(10.00) .394	(12.00) .472
-07	(9.00) .354	(12.00) .472	(14.00) .551

*Processing conditions will affect mated height. See SO Series for board space tolerances.



HIGH-SPEED SIGNAL & POWER COMBINATIONS

Q2™ Rugged Signal/Power

- Integral power/ground plane rated for up to 15.7 amps
- Optional integral power pins rated at 4 amps
- Wide variety of standard high-speed mating cable assemblies
- Combination signal/power cable assemblies
- 0.635 mm pitch with choice of stack heights
- Rugged contact system with increased insertion depth
- See QMS/QFS Series



Integral Power /
Ground Plane



Maximum
Insertion Depth

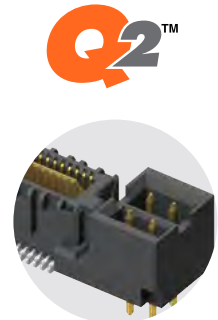

Optional Power Pins



Q Strip® High-Speed Signal/Power

- Integral power/ground plane rated for up to 25 amps
- Wide variety of standard high-speed mating cables
- Low profile (5 mm) to elevated (25 mm) stack heights
- Choice of pitches: QTH/QSH Series (0.50 mm pitch), QTS/QSS Series (0.635 mm pitch), and QTE/QSE Series (0.80 mm pitch)

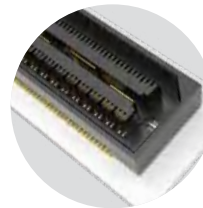

Single-Ended or
Differential Pair

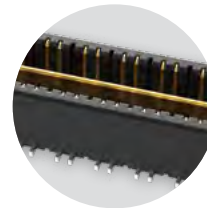

Surface Mount or
Through-Hole Power
Planes



Low Profile to
Elevated Stack
Heights



Q Rate® Slim Body High-Speed Signal/Power

- Widely accepted industry standard power/ground plane rated for up to 8.5 amps
- Signal Integrity optimized Edge Rate® contact is robust when “zippered” during unmating
- Slim 4.60 mm body width on 0.80 mm pitch
- 7 mm to 14 mm stack heights
- See QRM8/QRF8 Series

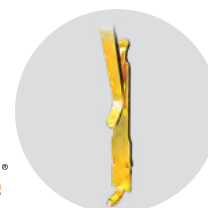

Edge Rate®
Contact System



Integral Power /
Ground Plane





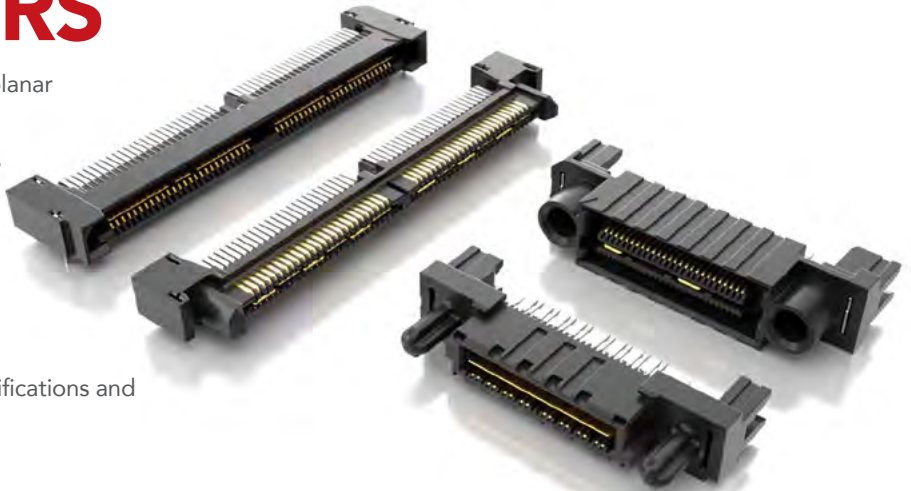

RIGHT-ANGLE & EDGE MOUNT HIGH-SPEED GROUND PLANE CONNECTORS

- Right-Angle and Edge Mount designs for coplanar and perpendicular mating
- Q Strip® Right-Angle High-Speed Connectors on 0.50 mm & 0.635 mm pitches
- Q2™ Right-Angle & Edge Mount Rugged High-Speed Connectors on 0.635 mm pitch
- Q Rate™ Right-Angle Slim Body High-Speed Connectors on 0.80 mm pitch
- Visit samtec.com/QSeries for complete specifications and ordering information





Q STRIP® HIGH-SPEED GROUND PLANE CONNECTORS

(0.50 mm) .0197" PITCH RIGHT-ANGLE GROUND PLANE HEADERS & SOCKETS

 QTH-RA Board Mates: QSH	SERIES	PINS PER ROW NO. OF PAIRS	01	PLATING	TYPE	RA	OTHER OPTION
	QTH Header	-030, -060, -090 -D = (60 total pins per bank)		-F = Gold Flash on contact, Matte Tin on tails	-D = Single-Ended		-PGP = Plastic Guide Post (QTH only)
 QSH-RA Board Mates: QTH	QSH Socket	-020, -040, -060 -D-DP = (20 pairs per bank)		-L = 10 μ" (0.25 μm) Gold contact, Matte Tin on tails	-D-DP = Differential Pair		-GP = Guide Post Holes (QSH only)
							-K = Polyimide film Pick & Place Pad

View complete specifications at: samtec.com?QTH-RA or samtec.com?QSH-RA

(0.635 mm) .025" PITCH RIGHT-ANGLE GROUND PLANE HEADER

 QTS-RA Board Mates: QSS	SERIES	POSITIONS PER ROW	01	PLATING	D	RA	WT	OTHER OPTION
	QTS Header	-025, -050, -075 (50 total Positions per bank)		-F = Gold Flash on Signal Pins and Ground Plane, Matte Tin on tails			-WT = Weld Tab (N/A with -025 Positions)	-SP = Solder Pin (QTS only)
 QSS-RA Board Mates: QTS Cable Mates: SQCD	QSS Socket			-L = 10 μ" (0.25 μm) Gold on Signal Pins and Ground Plane, Matte Tin on tails				

Note:
Some lengths, styles and options are non-standard, non-returnable.

View complete specifications at: samtec.com?QTS-RA or samtec.com?QSS-RA

Q2™ HIGH-SPEED GROUND PLANE CONNECTORS

(0.635 mm) .025" PITCH RIGHT-ANGLE GROUND PLANE HEADERS & SOCKETS

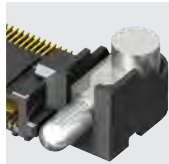

QMS-RA
Board Mates:
QFS



QFS-RA
Board Mates:
QMS

SERIES	PINS PER ROW NO. OF PAIRS	01	PLATING	TYPE	RA	MG	OTHER OPTION
QMS Header	-026, -052, -078 -D = (52 total pins per bank)		-SL = 10 μ" (0.25 μm) Gold on Signal Pins and Ground Plane, Matte Tin on tails	-D = Single-Ended -D-DP = Differential Pair		-MG = Metal Guide Post (QMS only)	-K = Polyimide film Pick & Place Pad -TR = Tape & Reel (-016, -026, -032 & -052 only) -FR = Full Reel Tape & Reel (must order max. quantity per reel; contact Samtec for quantity breaks) (-016, -026, -032 & -052 only)
QFS Socket	-016, -032, -048 -D-DP = (16 pairs per bank)						

View complete specifications at: samtec.com?QMS-RA or samtec.com?QFS-RA

(0.635 mm) .025" PITCH EDGE MOUNT GROUND PLANE HEADERS & SOCKETS



QMS-EM
Board Mates:
QFS



QFS-EM
Board Mates:
QMS

SERIES	POSITIONS PER ROW	01	PLATING	D	EM2	END OPTION	OTHER OPTION
QMS Header	-026, -052, -078		-SL = 10 μ" (0.25 μm) Gold on Signal Pins and Ground Plane, Matte Tin on tails			-PC4 = 4 Power Pins per end (QMS only)	-TR = Tape & Reel (-026 & -052 only) -FR = Full Reel Tape & Reel (must order max. quantity per reel; contact Samtec for quantity breaks) (-026 & -052 only)
QFS Socket							

View complete specifications at: samtec.com?QMS-EM or samtec.com?QFS-EM

Q RATE® SLIM BODY HIGH-SPEED GROUND PLANE CONNECTORS

(0.80 mm) .0315" PITCH RIGHT-ANGLE SLIM BODY GROUND PLANE HEADERS & SOCKETS

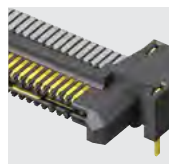

QRM8-RA
Board Mates:
QRF8
(-GP Required)

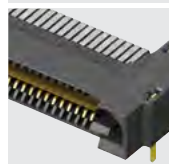

QRF8-RA
Board Mates:
QRM8
(-GP Required)

SERIES	POSITIONS PER ROW	01	PLATING	RA	GP	OPTION
QRM8 Header	-026, -052, -078 (52 total positions per bank)		-L = 10 μ" (0.25 μm) Gold contact, Matte Tin on tails		-GP = Guide Post (Requires -GP on mating connector)	-K = (7.00 mm) .275" DIA Polyimide film Pick & Place Pad (-052 only) -TR = Tape & Reel (-026, -052 only) -FR = Full Reel Tape & Reel (must order max. quantity per reel; contact Samtec for quantity breaks) (-026 & -052 only)
QRF8 Socket						

Note:
Some lengths, styles and options
are non-standard, non-returnable.

View complete specifications at: samtec.com?QRM8-RA or samtec.com?QRF8-RA

RUGGED HIGH-SPEED STRIPS



NRZ	PAM4
28 Gbps	56 Gbps

FEATURES & BENEFITS

Edge Rate® rugged high-speed connector strips are designed for high speed, high cycle applications, and enabled by Samtec's signal integrity-optimized Edge Rate® contact system.

- Choice of 0.50 mm, 0.635 mm or 0.80 mm pitch
- 0.50 mm pitch system offers up to 40% PCB space savings vs. 0.80 mm pitch
- 0.635 mm pitch system with extremely slim 2.5 mm body width
- Rugged latching, locking and 360° shielding
- Up to 1.5 mm contact wipe; robust when "zippered" during unmating
- Compatible with UMPT/UMPS for power/signal flexibility

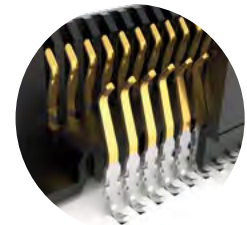

Signal integrity-optimized Edge Rate® contact system reduces broadside coupling

EDGE RATE® STACK HEIGHT FLEXIBILITY

(actual size in mm)

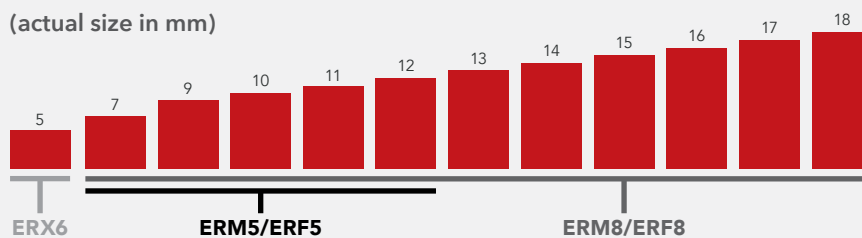

Sockets shown actual size with 40 total positions

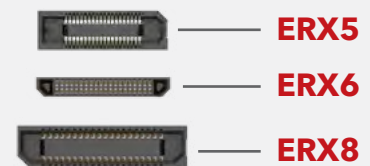

KEY SPECIFICATIONS

SERIES	PITCH	STACK HEIGHTS	TOTAL PINS / PAIRS	INSULATOR MATERIAL	TERMINAL MATERIAL	PLATING	OPERATING TEMP RANGE	LEAD-FREE SOLDERABLE
ERM5 / ERF5	0.50 mm	7-12 mm	20-150	Black LCP	Phosphor Bronze or BeCu (ERM5), BeCu (ERF5)	Au or Sn over 50 μm (1.27 μm) Ni	-55 °C to +125 °C	Yes
ERM6 / ERF6	0.635 mm	5 mm	20-120		Copper Alloy			
ERM8 / ERF8	0.80 mm	7-18 mm	10-200		Phosphor Bronze or BeCu (ERM8), BeCu (ERF8)			

(0.50 mm) .0197" PITCH • RUGGED HIGH-SPEED STRIPS

SERIES	POSITIONS PER ROW	LEAD STYLE	PLATING OPTION	DV	PICK & PLACE PAD	"X"R
ERM5 Header	-010, -020, -030, -040, -050, -060, -070, -075	-02.0 = 2 mm Body Height (ERM5 only)	-L = 10 μ" (0.25 μm) Gold on contact, Matte Tin on Tail		(required in callout)	-TR = Tape & Reel
		-04.0 = 4 mm Body Height (ERM5 only)			-K = (3.50 mm) .138" DIA Polyimide Film Pick & Place Pad (ERM5 -04.0 -05.0 and Lead Style only)	-FR = Full Reel Tape & Reel (must order maximum quantity per reel; contact Samtec for quantity breaks)
ERF5 Socket		-05.0 = 5 mm Body Height			= (6.00 mm) .236" DIA Polyimide Film Pick & Place Pad (ERF5 only)	
		-07.0 = 7 mm Body Height (ERF5 only & Available up to 50 Pos. only)			-P = Plastic Pick & Place Pad (ERM5 -02.0 Lead Style only; ERM5 -010 Positions and ERF5 Not Available)	

ERM5
Board Mates:
ERF5

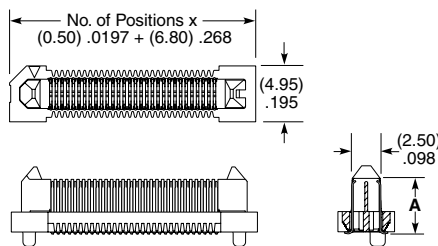
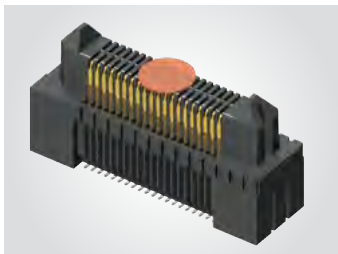

LEAD STYLE	A (ERM5)	B (ERF5)
-02.0	(4.84) .191	N/A
-04.0	(6.84) .269	N/A
-05.0	(7.84) .309	(4.91) .193
-07.0	N/A	(6.91) .272

ERF5
Board Mates:
ERM5

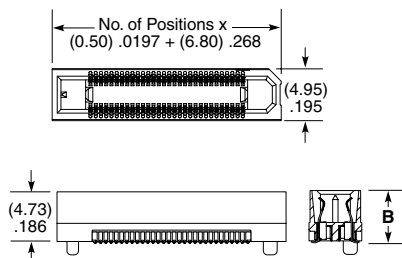

MATED HEIGHT*		
ERM5 LEAD STYLE	ERF5 LEAD STYLE	
	-05.0	-07.0
-02.0	(7.00) .276	(9.00) .354
-04.0	(9.00) .354	(11.00) .433
-05.0	(10.00) .394	(12.00) .472

*Processing conditions will affect mated height.

View complete specifications at: samtec.com?ERM5 or samtec.com?ERF5

ERF5	POSITIONS PER ROW	01	PLATING OPTION	D	RA	"X"R
------	-------------------	----	----------------	---	----	------

Right-Angle
Socket

-010, -020, -030,
-040, -050

-L
= 10 μ" (0.25 μm) Gold on contact, Matte Tin on tail

-TR
= Tape & Reel

ERF5-RA
Board Mates:
ERM5

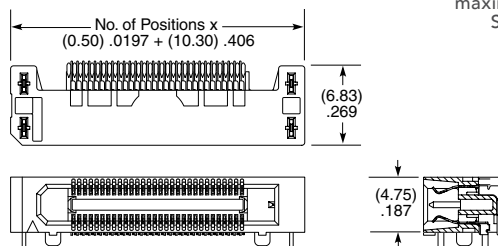

-FR
= Full Reel Tape & Reel (must order maximum quantity per reel; contact Samtec for quantity breaks)

Note:
Some lengths, styles and options are non-standard, non-returnable.

View complete specifications at: samtec.com?ERF5-RA

(0.635 mm) .025" PITCH • RUGGED HIGH-SPEED HEADERS & SOCKETS

ERM6 - **POSITIONS PER ROW** - **01.5** - **PLATING OPTION** - **DV** - **A** - **OPTION** - **K** - **"X"R**

**-010, -020, -030,
-040, -050, -060**
(Standard Sizes)

-L
= 10 μ" (0.25 μm)
Gold on contact,
Matte Tin on tail

(Leave Blank for
No Weld Tab Pin)

-WT
= Weld Tab

-TR
= Tape & Reel

-FR
= Full Reel Tape & Reel
(must order maximum quantity
per reel; contact Samtec for
quantity breaks)

ERM6
Board Mates:
ERF6

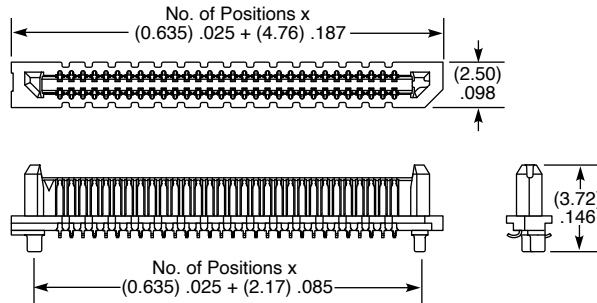
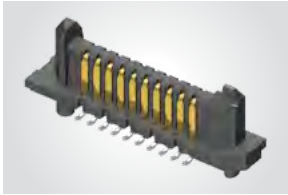

MATED HEIGHT*

ERF6 LEAD STYLE	ERM6 LEAD STYLE
-03.5	(5.00) .197

*Processing conditions will affect mated height.

View complete specifications at: samtec.com?ERM6

ERF6 - **POSITIONS PER ROW** - **03.5** - **PLATING OPTION** - **DV** - **A** - **OPTION** - **K** - **"X"R**

**-010, -020, -030,
-040, -050, -060**
(Standard Sizes)

-L
= 10 μ" (0.25 μm)
Gold on contact,
Matte Tin on tail

(Leave Blank for
No Weld Tab Pin)

-WT
= Weld Tab

-TR
= Tape & Reel

-FR
= Full Reel Tape & Reel
(must order maximum quantity
per reel; contact Samtec for
quantity breaks)

ERF6
Board Mates:
ERM6

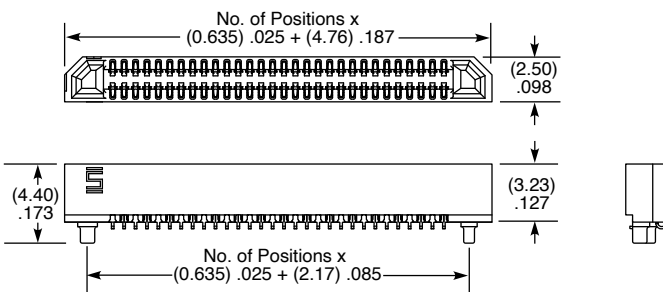

MATED HEIGHT*

ERF6 LEAD STYLE	ERM6 LEAD STYLE
-03.5	(5.00) .197

*Processing conditions will affect mated height.

View complete specifications at: samtec.com?ERF6

Notes:

Kapton pad and tape & reel packaging are standard.
Some lengths, styles and options are non-standard, non-returnable.

(0.80 mm) .0315" PITCH • RUGGED HIGH-SPEED HEADERS & SOCKETS

TYPE	POSITIONS PER ROW	LEAD STYLE	PLATING OPTION	DV	OPTIONS	"X"R
------	-------------------	------------	----------------	----	---------	------

ERM8
= Header
ERF8
= Socket

-050, -010, -011, -013, -020, -025, -030, -035, -040, -049, -050, -060, -070, -075, -100

(100 Position Only Available with ERM8-09.0 & ERF8-05.0 Lead Styles; -L or -EPG N/A)

SPECIFY LEAD STYLE FROM CHART

-L
= 10 μ" (0.25 μm) Gold on contact, Matte Tin on tail
-S
= 30 μ" (0.76 μm) Gold on contact, Matte Tin on tail

-DS
= Differential Pair (ERM8 -05.0 Lead Style with -010, -013, -025, -049 Positions only)
-L
= Latching (ERM8-05.0 & -09.0 Lead Styles only & -EGP Option N/A) (ERF8-05.0 Lead Style only and -L to -EGP Option N/A)

-TR
= Tape & Reel
-FR
= Full Reel Tape & Reel (must order maximum quantity per reel; contact Samtec for quantity breaks)

-EGP
= Extended Guide Post (ERM8-05.0 & ERF8-07.0 Lead Style Only & -L Option N/A)
-DSP
= Differential Pair with Extended Guide Post (ERM8 -05.0 Lead Style with -013 and -025 Positions only)

-K
= Polyimide Film Pick & Place Pad (-02.0 Lead Style N/A)
-P
= Pick & Place Pad (ERM8 and -02.0 & -05.0 Lead Styles only)

ERM8
Board Mates:
ERF8
ERM8
Cable Mates:
ERCD, ERDP

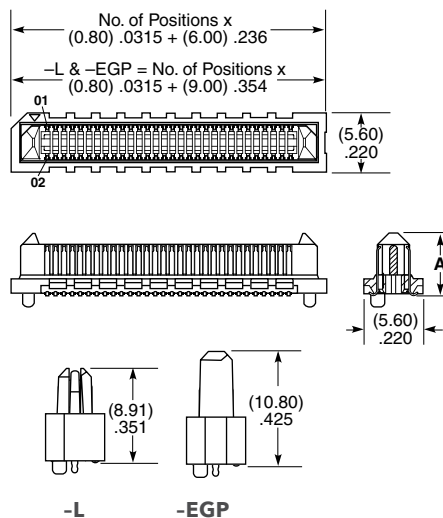

View complete specifications at: samtec.com?ERM8

LEAD STYLE	A (ERM8)	B (ERF8)
-02.0	(5.97) .235	N/A
-05.0	(8.91) .351	(5.10) .200
-07.0	N/A	(7.00) .276
-08.0	(11.91) .469	N/A
-09.0	(12.91) .508	(9.00) .354

ERF8
Board Mates:
ERM8
ERF8
Cable Mates:
ERCD, ERDP

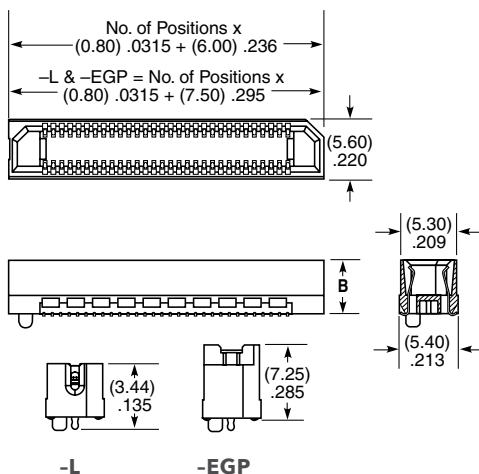
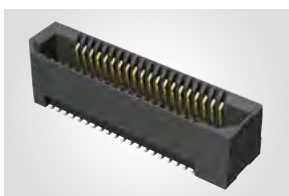

View complete specifications at: samtec.com?ERF8

ERM8 LEAD STYLE	MATED HEIGHT*		
	ERF8 LEAD STYLE		
	-05.0	-07.0	-09.0
-02.0	(7.00) .276	(9.00) .354	(11.00) .433
-05.0	(10.00) .394	(12.00) .472	(14.00) .551
-08.0	(13.00) .512	(15.00) .591	(17.00) .669
-09.0	(14.00) .551	(16.00) .629	(18.00) .709

*Processing conditions will affect mated height.

Note:
Some lengths, styles and options are non-standard, non-returnable.

See pg 52-53 for Right-Angle & Edge Mount options, pg 54 for Shielded options.

(0.80 mm) .0315" PITCH • RIGHT-ANGLE & EDGE MOUNT HIGH-SPEED HEADERS

ERM8	POSITIONS PER ROW	01	PLATING OPTION	D	RA	OPTIONS	"X"R
Right-Angle Terminal	-010, -013, -020, -025, -030, -040, -049, -050, -060, -070, -075		-L = 10 μm (0.25 μm) Gold on contact area, Matte Tin on tail			-K = (6.00 mm) .236" DIA Polyimide Film Pick & Place Pad -L = Latching -DS = Differential Pair (-013, -025 Position only) (Hot Swap)	-TR = Tape & Reel -FR = Full Reel Tape & Reel (must order maximum quantity per reel; contact Samtec for quantity breaks)

ERM8-RA
Board Mates: ERF8
Cable Mates: ERCD

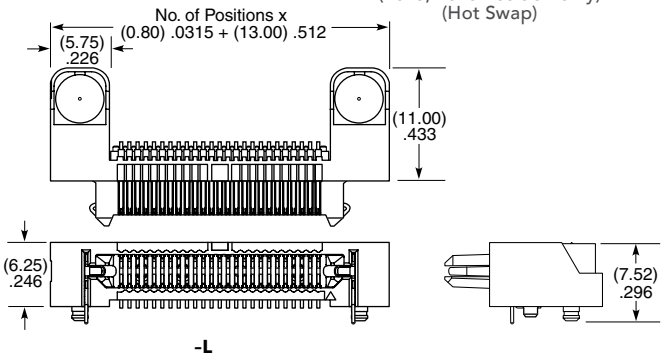
View complete specifications at: samtec.com?ERM8-RA

ERM8	POSITIONS PER ROW	01	PLATING OPTION	D	EM2	OPTIONS	"X"R
Edge Mount Terminal	-010, -013, -020, -025, -030, -040, -049, -050, -060, -070, -075		-L = 10 μm (0.25 μm) Gold on contact area, Matte Tin on tail		= (1.60 mm) .062" Thick PCB	-L = Latching (Mates to ERF8 Lead Style -05.0 or -RA Only) -DS = Differential Pair (-013 & -025 Position only) (Hot Swap) -EGPS = Extended Guide Post Shield (-010, -020, -025, -030 Position Only) -DSS = Differential Pair + Extended Guide Post Shield (-025 Position Only) (Hot Swap)	-TR = Tape & Reel -FR = Full Reel Tape & Reel (must order maximum quantity per reel; contact Samtec for quantity breaks)

ERM8-EM
Board Mates: ERF8
Cable Mates: ERCD

View complete specifications at: samtec.com?ERM8-EM

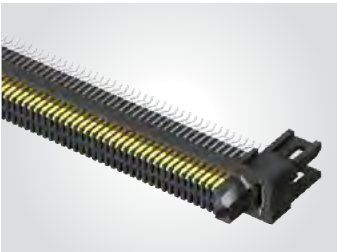
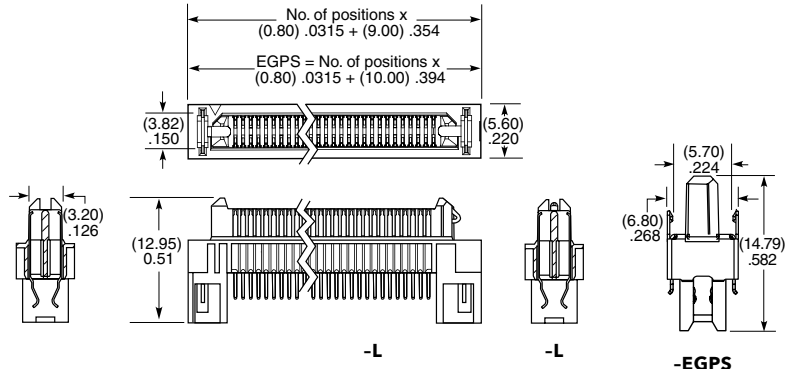
Note:
Some lengths, styles and options are non-standard, non-returnable.

(0.80 mm) .0315" PITCH • RIGHT-ANGLE & EDGE MOUNT HIGH-SPEED SOCKETS

ERF8	POSITIONS PER ROW	01	PLATING OPTION	D	RA	OPTIONS	"X"R
------	-------------------	----	----------------	---	----	---------	------

Right-Angle Socket

-010, -013, -020,
-025, -030, -040,
-049, -050, -060,
-070, -075

-L
= 10 μ" (0.25 μm)
Gold on contact area, Matte Tin on tail

-L
= Latching
(N/A with -EGP Option)

-EGP
= Extended Guide Post
(N/A with -L Option)

-TR
= Tape & Reel

-FR
= Full Reel Tape & Reel (must order maximum quantity per reel; contact Samtec for quantity breaks)

ERF8-RA
Board Mates:
ERM8
Cable Mates:
ERCD, ERDP

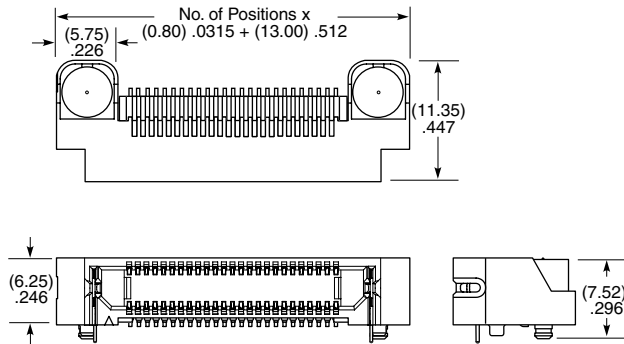

View complete specifications at: samtec.com?ERF8-RA

ERF8	POSITIONS PER ROW	01	PLATING OPTION	D	EM2	OPTIONS	"X"R
------	-------------------	----	----------------	---	-----	---------	------

Edge Mount Socket

-010, -013,
-020, -025,
-030, -040,
-049, -050,
-060, -070,
-075

-L
= 10 μ" (0.25 μm)
Gold on contact area, Matte Tin on tail

= (1.60 mm) .062" Thick PCB

-EGPS
= Extended Guide Post Shield
(-010, -020, -025, -030 Pos. only)

-TR
= Tape & Reel

-FR
= Full Reel Tape & Reel (must order maximum quantity per reel; contact Samtec for quantity breaks)

ERF8-EM
Board Mates:
ERM8

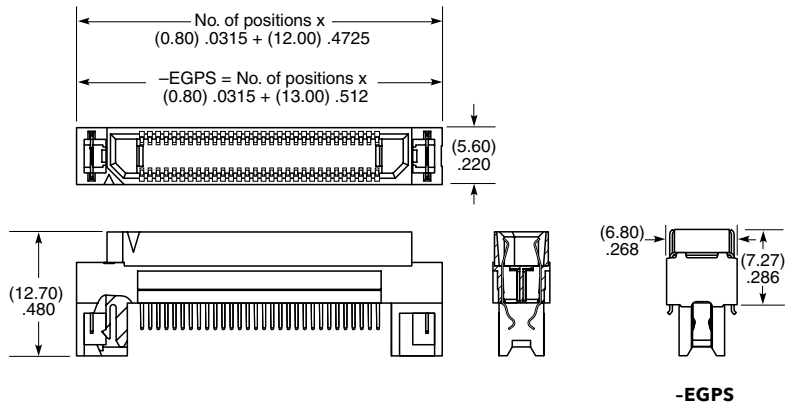

View complete specifications at: samtec.com?ERF8-EM

Note:
Some lengths, styles and options are non-standard, non-returnable.

(0.80 mm) .0315" PITCH • SHIELDED HIGH-SPEED HEADERS & SOCKETS

TYPE	POSITIONS PER ROW	LEAD STYLE	PLATING OPTION	DV	OPTIONS	"X"R
ERM8 = Shielded Terminal	-010, -020, -025, -030	-02.0 = 2 mm (ERM8 with -S only)	-L = 10 μ" (0.25 μm) Gold on contact, Matte Tin on tail		-S = Shield (Lead Styles: ERM8 -02.0 only; ERF8 -05.0 only)	-TR = Tape & Reel
ERF8 = Shielded Socket		-05.0 = 5 mm (ERF8 with -S & ERM8 with -EGPS & -DSS only)	-S = 30 μ" (0.76 μm) Gold on contact, Matte Tin on tail		-EGPS = Extended Guide Post Shield (Lead Styles: ERM8 -05.0 & -09.0 only; ERF8 -07.0 only)	-FR = Full Reel Tape & Reel (must order maximum quantity per reel; contact Samtec for quantity breaks)
		-07.0 = 7 mm (ERF8 with -EGPS only)			-DSS = Differential Pair with Extended Guide Post Shield (ERM8 only, with -05.0 & -09.0 Lead Styles, -10 & -025 Pos. only)	
		-09.0 = 9 mm (ERM8 with -EGPS & -DSS only)			-K = Polyimide Film Pick & Place Pad (-02.0 Lead Style N/A)	
					-P = Pick & Place Pad (ERM8 -02.0 & -05.0 Lead Styles only)	

ERM8-S

Board Mates:

See "Mated Height" Chart

(Note: ERF8-S does not mate with ERM8-EGPS)

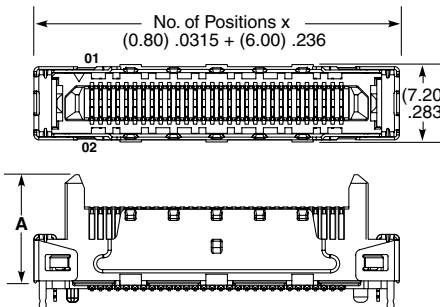
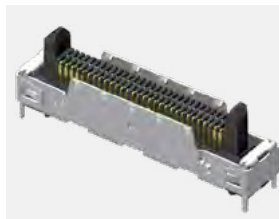

LEAD STYLE	A	B
-05.0	(9.87) .389	(10.81) .425
-09.0	(13.87) .546	(14.81) .583

-S OPTION

-EGPS OR -DSS OPTION

View complete specifications at: samtec.com?ERM8

ERF8-S

Board Mates:

See "Mated Height" Chart

(Note: ERM8-EGPS does not mate with ERF8-S)

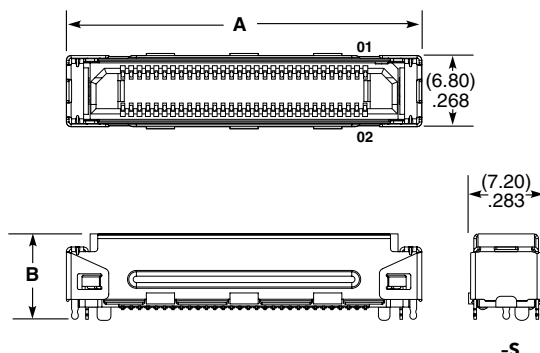

LEAD STYLE	B (-S)	B (-EGPS)
-05.0	(5.90) .232	N/A
-07.0	N/A	(7.42) .292

POSITIONS PER ROW	A
-010	(18.00) .71
-020	(26.00) 1.02
-025	(30.00) 1.18
-030	(34.00) 1.34

-S

View complete specifications at: samtec.com?ERF8

Note:

Some lengths, styles and options are non-standard, non-returnable.

ULTRA MICRO INTERCONNECTS

SPACE SAVING DESIGNS • RUGGED HERMAPHRODITIC • ULTRA FINE PITCH

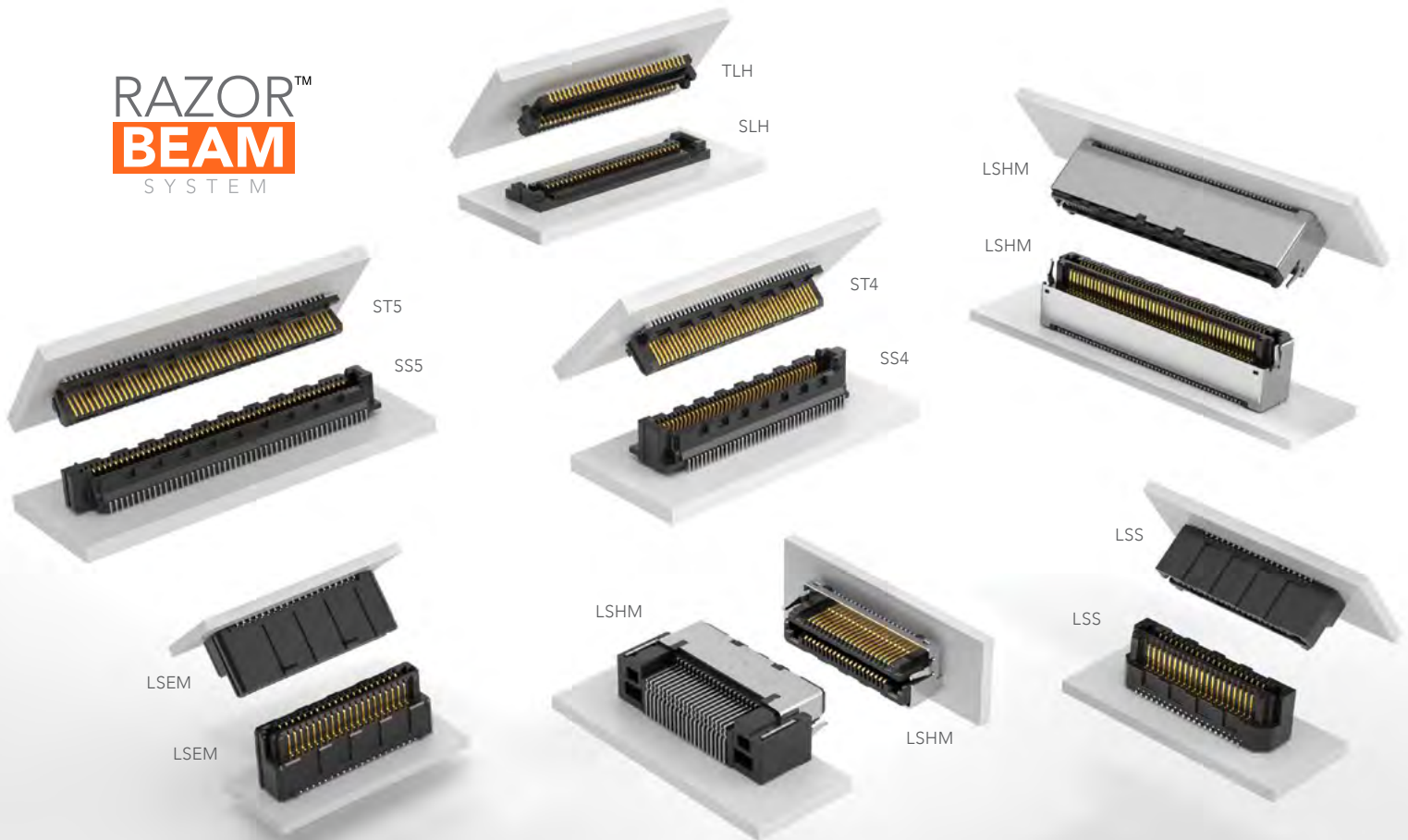

56-58

RAZOR BEAM™

0.50 mm Pitch Hermaphroditic Connectors (LSHM)	56-57
0.635 mm Pitch Hermaphroditic Connectors (LSS)	58
0.80 mm Pitch Hermaphroditic Connectors (LSEM)	58

59-61

MICRO BLADE & BEAM STRIPS

0.40 mm Pitch Low-Profile Strips (ST4, SS4)	59
0.50 mm Pitch Low-Profile Strips (ST5, SS5, SLH, TLH)	60-61

FINE PITCH SELF MATING CONNECTORS

(0.50 mm) .0197" PITCH

FEATURES & BENEFITS

- Ten stack height options from 5.00 mm to 12.00 mm
- 0.50 mm, 0.635 mm or 0.80 mm pitches
- Audible click when mated
- Mating and unmating forces approximately 4-6x greater than typical micro pitch connectors
- Self-mating system reduces inventory cost
- Parallel, perpendicular and coplanar systems
- Shield option
- Lubricated option

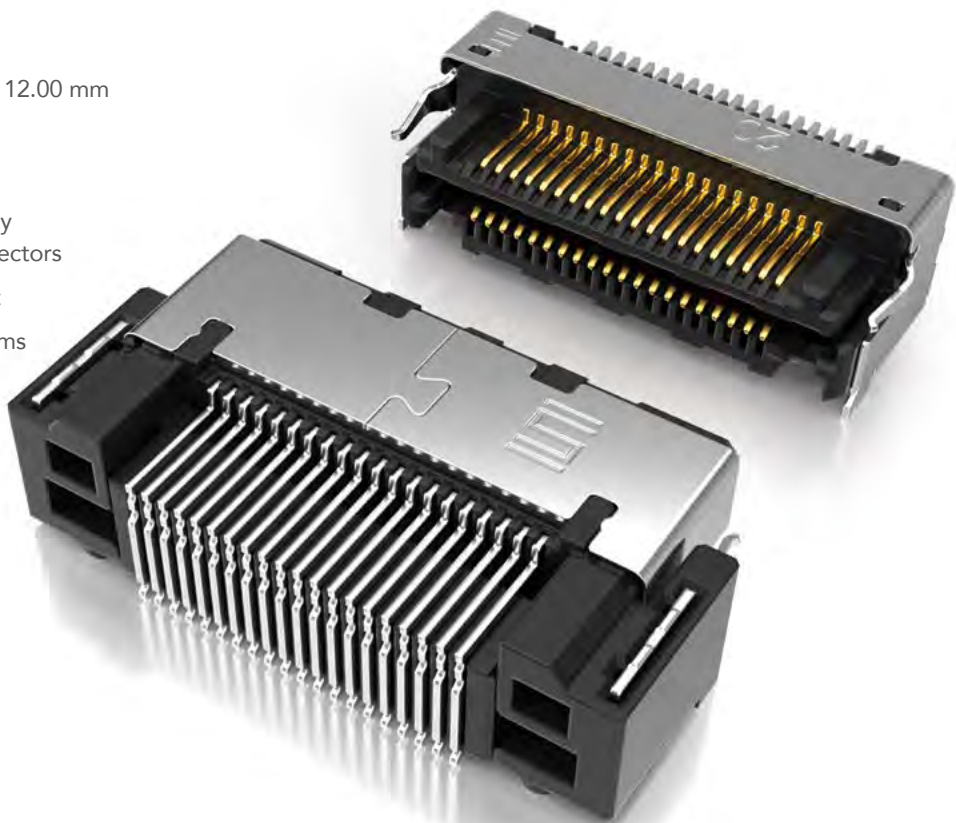

ACTUAL SIZE SHOWN SLIM BODY DESIGNS (40 total positions each)

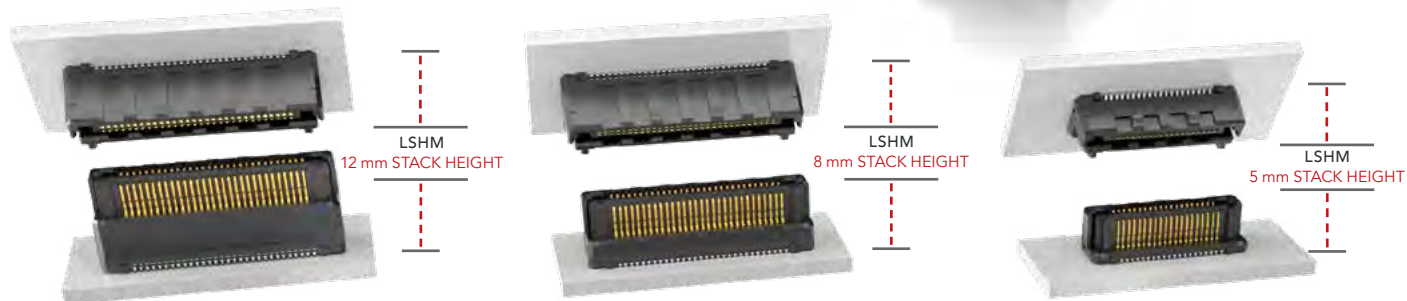

KEY SPECIFICATIONS

INSULATOR MATERIAL	CONTACT MATERIAL	PLATING	OPERATING TEMP RANGE	CURRENT RATING	SMT COPLANARITY	LEAD-FREE SOLDERABLE
Black LCP	Phosphor Bronze	Au or Sn over 50 μ" (1.27 μm) Ni	-55 °C to +125 °C	LSHM: 2.0 A per pin LSS: 1.7 A per pin LSEM: 1.8 A per pin	(0.10 mm) .004" max	Yes

(0.50 mm) .0197" PITCH • RUGGED HERMAPHRODITIC CONNECTORS

LSHM	1	NO. PINS PER ROW	LEAD STYLE	PLATING OPTION	TAIL OPTION	A	SHIELD OPTION	K	"X"R
		05, 10, 20, 30, 40, 50	(Vertical) Specify LEAD STYLE from chart (Right-angle) -01 = Standard (Right-angle) -L1 = Lubricated	-F = Gold flash on contact, Matte Tin on tail -L = 10 μ" (0.25 μm) Gold on contact, Matte Tin on tail	-DV = Vertical -DH = Right-angle (Lead style -01 & -L1 only) -RH = Reverse Right-angle (Lead style -01 & -L1 only)		-S = With Shield -N = Without Shield	-K = (3.50 mm) .138" DIA Polyimide film Pick & Place Pad	-TR = Tape & Reel -FR = Full Reel Tape & Reel (must order maximum quantity per reel; contact Samtec for quantity breaks)

LSHM

Board Mates:
LSHM
Cable Mates:
HLCD

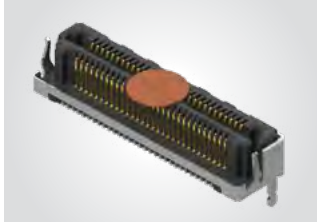

LEAD STYLE (STANDARD)	LEAD STYLE (LUBRICATED)	A	B
-02.5	-L2.5	(3.95) .156	(1.00) .039
-03.0	-L3.0	(4.45) .175	(1.50) .059
-04.0	-L4.0	(5.45) .215	(2.50) .098
-06.0	-L6.0	(7.45) .293	(4.50) .177

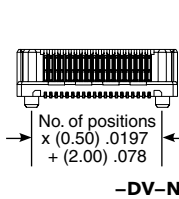
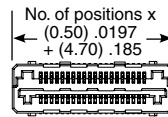

-DV-N

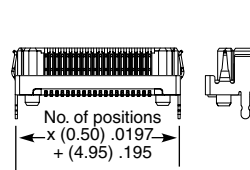
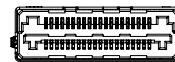

-DV-S

LEAD STYLE	MATED HEIGHT *
-02.5 & -02.5	(5.00) .196
-02.5 & -03.0	(5.50) .217
-03.0 & -03.0	(6.00) .236
-02.5 & -04.0	(6.50) .256
-03.0 & -04.0	(7.00) .276
-04.0 & -04.0	(8.00) .315
-02.5 & -06.0	(8.50) .335
-03.0 & -06.0	(9.00) .354
-04.0 & -06.0	(10.00) .394
-06.0 & -06.0	(12.00) .472

*Processing conditions will affect mated height.

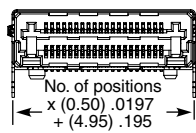
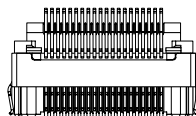

-DH-S

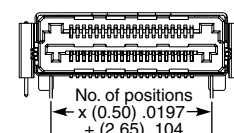
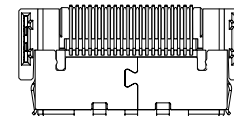
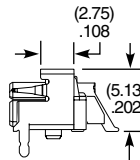

-RH-S

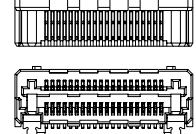
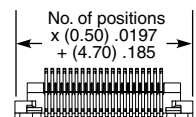
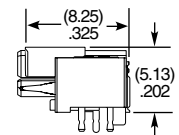

-DH-N

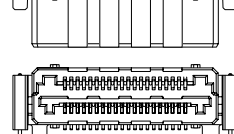
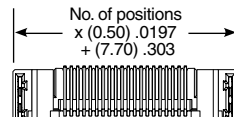
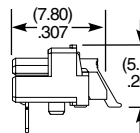

-RH-N

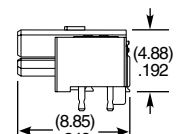

Note:
Some lengths, styles and options are non-standard, non-returnable.

View complete specifications at: samtec.com?LSHM

(0.635 mm) .025" PITCH • RUGGED HERMAPHRODITIC CONNECTORS

LSS - **1** **NO. PINS PER ROW** - **LEAD STYLE** - **PLATING OPTION** - **DV** - **A** - **OPTION**

10, 20, 30, 40, 50

Specify **LEAD STYLE** from chart

-F
= Gold flash on contact, Matte Tin on tail

-L
= 10 μ" (0.25 μm) Gold on contact, Matte Tin on tail

-K
= (3.50 mm) .138" DIA Polyimide film Pick & Place Pad

-TR
= Tape & Reel

-FR
= Full Reel Tape & Reel (must order maximum quantity per reel; contact Samtec for quantity breaks)

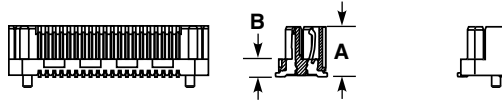
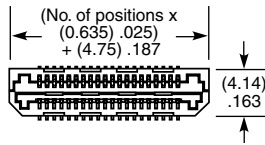
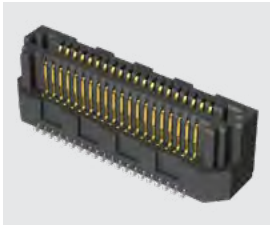

LEAD STYLE	A	B
-01	(4.45) .1752	(1.59) .0628
-02	(7.45) .2933	(4.59) .1808
-03	(5.45) .2146	(2.59) .1021

LEAD STYLE	MATED HEIGHT *
-01 & -01	(6.00) .236
-01 & -03	(7.00) .276
-03 & -03	(8.00) .315
-01 & -02	(9.00) .354
-02 & -03	(10.00) .394
-02 & -02	(12.00) .472

*Processing conditions will affect mated height.

View complete specifications at: samtec.com?LSS

(0.80 mm) .0315" PITCH • RUGGED HERMAPHRODITIC CONNECTORS

LSEM - **1** **NO. PINS PER ROW** - **LEAD STYLE** - **PLATING OPTION** - **TAIL OPTION** - **A** - **N** - **K** - **"X"R**

10, 20, 30, 40, 50

Specify **LEAD STYLE** from chart

-F
= Gold flash on contact, Matte Tin on tail

-L
= 10 μ" (0.25 μm) Gold on contact, Matte Tin on tail

-DV
= Vertical

-DH
= Right-angle (Lead style -01 only)

-K
= (3.50 mm) .138" DIA Polyimide film Pick & Place Pad

-TR
= Tape & Reel

-FR
= Full Reel Tape & Reel (must order maximum quantity per reel; contact Samtec for quantity breaks)

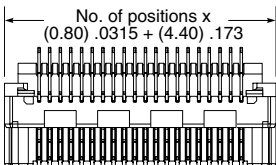

LEAD STYLE	A	B
-01 (-DH only)	N/A	NA
-03.0	(4.45) .175	(1.50) .059
-04.0	(5.45) .215	(2.50) .098
-06.0	(7.45) .293	(4.50) .177

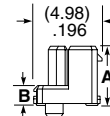
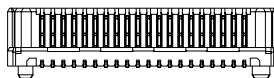
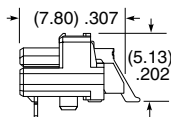
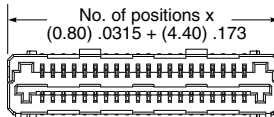

LEAD STYLE	MATED HEIGHT *
-03.0 & -03.0	(6.00) .236
-03.0 & -04.0	(7.00) .276
-04.0 & -04.0	(8.00) .315
-03.0 & -06.0	(9.00) .354
-04.0 & -06.0	(10.00) .394
-06.0 & -06.0	(12.00) .472

*Processing conditions will affect mated height.

Note: Some lengths, styles and options are non-standard, non-returnable.

-DH

-DV

View complete specifications at: samtec.com?LSEM

MICRO BLADE & BEAM SOCKET & HEADER

28
Gbps

(0.40 mm) .0158" PITCH • SS4/ST4 SERIES



SS4
Mates:
ST4

ST4
Mates:
SS4

SPECIFICATIONS

Insulator Material:
Black LCP
Contact Material:
Phosphor Bronze
Plating:
Au or Sn over
50 μ" (1.27 μm) Ni
Operating Temp Range:
-55 °C to +125 °C
Current Rating:
1.6 A per pin
(2 pins powered)

PROCESSING

Lead-Free Solderable:
Yes
SMT Lead Coplanarity:
(0.10 mm) .004" max

SS4	POSITIONS PER ROW	LEAD STYLE	PLATING OPTION	D	K	"X"R
-----	-------------------	------------	----------------	---	---	------

-10, -20,
-30, -40, -50

-3.00
= 3.00 mm

-L
= 10 μ"
(0.25 μm)
Gold on contact,
Matte Tin on tail

(Required in callout)

-K
= (3.50 mm)
.138" DIA
Polyimide
Film
Pick &
Place Pad

(Required in callout)

-TR
= Tape & Reel

-FR
= Full Reel
Tape & Reel
(must order max.
quantity per reel;
contact Samtec for
quantity breaks)

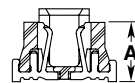
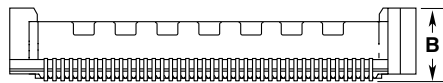
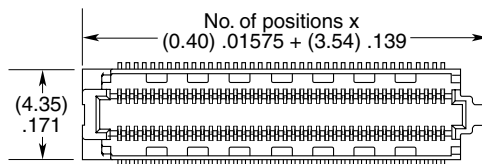

LEAD STYLE	A	B
-3.00	(2.85) .112	(3.50) .138
-3.50	(3.35) .132	(4.00) .157

ST4	POSITIONS PER ROW	LEAD STYLE	PLATING OPTION	D	P	"X"R
-----	-------------------	------------	----------------	---	---	------

-10, -20,
-30, -40, -50

-1.00
= 1.00 mm

-1.50
= 1.50 mm

-2.50
= 2.50 mm

-L
= 10 μ"
(0.25 μm)
Gold on contact,
Matte Tin on tail

(Required in callout)

-P
= Pick &
Place Pad

(Required in callout)

-TR
= Tape & Reel

-FR
= Full Reel
Tape & Reel
(must order max.
quantity per reel;
contact Samtec for
quantity breaks)

MATED HEIGHT *

ST4 LEAD STYLE	SS4 LEAD STYLE	
	-3.00	-3.50
-1.00	(4.00 mm) .157"	(4.50 mm) .177"
-1.50	(4.50 mm) .177"	(5.00 mm) .197"
-2.50	(5.50 mm) .217"	(6.00 mm) .236"

*Processing conditions will affect mated height.

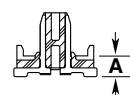
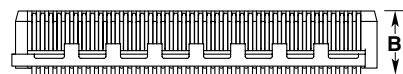
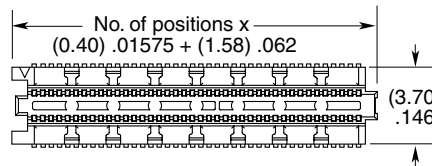

LEAD STYLE	A	B
-1.00	(1.00) .039	(3.08) .121
-1.50	(1.50) .059	(3.58) .141
-2.50	(2.50) .098	(4.58) .180

Note:
Some lengths, styles and options are non-standard, non-returnable.

MICRO BLADE & BEAM SOCKET & HEADER

(0.50 mm) .0197" PITCH • SS5/ST5 SERIES

PAM 4

56
Gbps

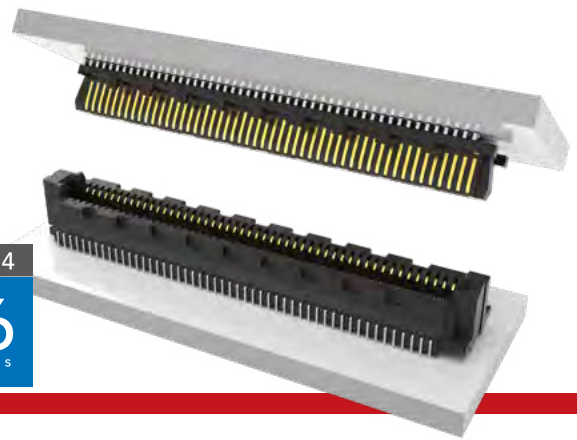

SS5
Mates:
ST5

ST5
Mates:
SS5

SPECIFICATIONS

Insulator Material:
Black LCP
Contact Material:
Phosphor Bronze
Plating:
Au or Sn over
50 μ" (1.27 μm) Ni
Operating Temp Range:
-55 °C to +125 °C
Current Rating:
1.6 A per pin
(2 pins powered)

PROCESSING

Lead-Free Solderable:
Yes
SMT Lead Coplanarity:
(0.10 mm) .004" max

SS5	NO. OF POSITIONS	LEAD STYLE	PLATING OPTION	D	K	"X"R
	-10, -15, -20, -30, -40, -50, -60, -70, -80 (Per Row)	-3.00 = 3.00 mm -3.50 = 3.50 mm	-L = 10 μ" (0.25 μm) Gold on contact, Matte Tin on tail		(Required in callout) -K = (3.50 mm) .138" DIA Polyimide Film Pick & Place Pad	(Required in callout) -TR = Tape & Reel -FR = Full Reel Tape & Reel (must order max. quantity per reel; contact Samtec for quantity breaks)

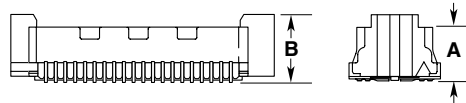
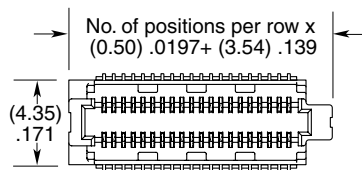

LEAD STYLE	A	B
-3.00	(2.85) .112	(3.50) .138
-3.50	(3.35) .132	(4.00) .157

MATED HEIGHT *

ST5 LEAD STYLE	SS5 LEAD STYLE	
-1.00	(4.00 mm) .157"	(4.50 mm) .177"
-1.50	(4.50 mm) .177"	(5.00 mm) .197"

*Processing conditions will affect mated height.

ST5	NO. OF POSITIONS	LEAD STYLE	PLATING OPTION	D	P	"X"R
	-10, -15, -20, -30, -40, -50, -60, -70, -80 (Per Row)	-1.00 = 1.00 mm -1.50 = 1.50 mm	-L = 10 μ" (0.25 μm) Gold on contact, Matte Tin on tail		(Required in callout) -P = Pick & Place Pad	(Required in callout) -TR = Tape & Reel -FR = Full Reel Tape & Reel (must order max. quantity per reel; contact Samtec for quantity breaks)

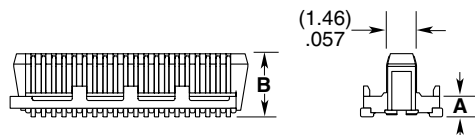
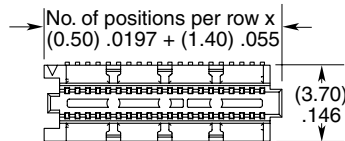

LEAD STYLE	A	B
-1.00	(1.00) .039	(3.08) .121
-1.50	(1.50) .059	(3.58) .141

ALSO AVAILABLE

Other lead styles
(MOQ Required)

Note:
Some lengths, styles and options are non-standard, non-returnable.

ULTRA-LOW PROFILE HEADER & SOCKET

(0.50 mm) .0197" PITCH • SLH/TLH SERIES

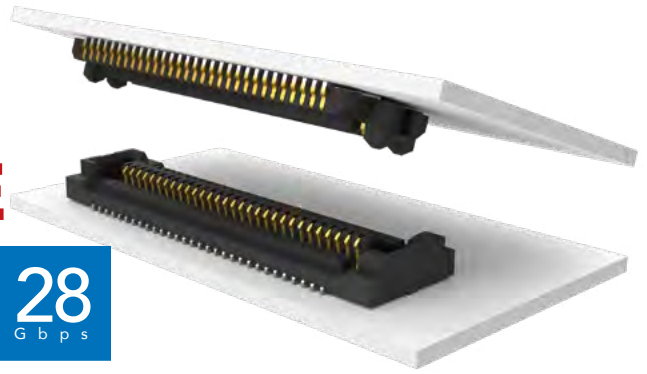

SLH
Mates:
TLH

TLH
Mates:
SLH

SLH	NO. OF POSITIONS	LEAD STYLE	PLATING OPTION	D	OPTION	OPTION
	-010, -020, -030 (Per Row)	-1.50 =1.50 mm	-G = 10 μm (0.25 μm) Gold in contact, Gold flash on tail		-A = Alignment Pin	-K = (3.00 mm) .118" DIA Polyimide Film Pick & Place Pad

SPECIFICATIONS

Insulator Material:
Black Liquid Crystal Polymer
Contact Material:
Copper Alloy
Plating:
Au over 50 μm (1.27 μm) Ni
Current Rating:
2.1 A per pin
(2 pins powered)
Operating Temp Range:
-55 °C to +125 °C

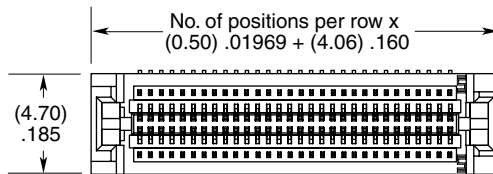

PROCESSING

Lead-Free Solderable:
Yes
SMT Lead Coplanarity:
(0.10 mm) .004" max
Board Stacking:
For applications requiring two
or more connectors per board,
contact ipg@samtec.com

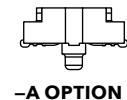
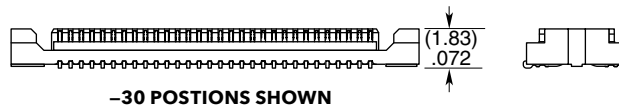

-A OPTION

TLH	NO. OF POSITIONS	LEAD STYLE	PLATING OPTION	D	OPTION	OPTION
	-010, -020, -030 (Per Row)	-0.50 =0.50 mm	-G = 10 μm (0.25 μm) Gold in contact, Gold flash on tail		-A = Alignment Pin	-K = (3.00 mm) .118" DIA Polyimide Film Pick & Place Pad

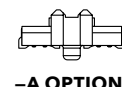
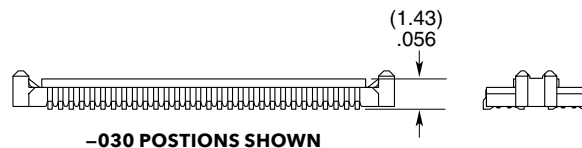
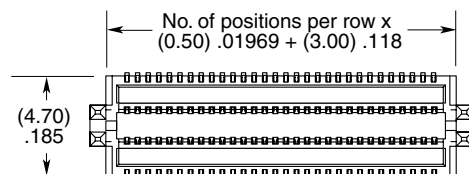

-A OPTION

Note:
Some lengths, styles and
options are non-standard,
non-returnable.

PRECISION BOARD STACKING STANDOFF



SO SERIES

SPECIFICATIONS

Material:
Aluminum
Locking Compound:
Nylon

SO

**BOARD
STACKER**

Specify
BOARD STACKER
from chart

**LEAD
STYLE**

-01
= Female Thread/Press-In
(-0515 thru -0865 only)

-02
= Male/Male Thread
(-0515 and
-1115 thru -2515 only)

-03
= Male/Female Thread
(-0815 thru -2515 only)

-05
= Female/Female Thread
(-1524 thru -2515 only)

**THREAD
STYLE**

-01
= #4-40
Thread

-02
= M3 x 0.5
Thread

01

L

-L
= -02 & -03
Lead Style
thread locking
compound
(Leave blank for
-01 Lead Style)

INDUSTRY STANDARD SOLUTIONS

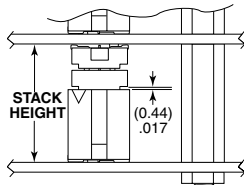

Requires Standoff
SO-1524-03-01-01-L or
JSOM-1524-02 for 15.24 mm
or SO-2215-02-01-01-L
for 22 mm board spacing.
Connectors designed to not
fully seat when mated.

For more information on the JSOM,
visit samtec.com?JSOM

INDUSTRY STANDARD	INTERCONNECTS			
	TERMINAL	SOCKET	BANKS	STACK HEIGHT
SUMIT™	ASP-129637-01	ASP-129646-01	1	15.24 mm
PCI/104-Express™	ASP-129637-03	ASP-129646-03	3	15.24 mm
PCI/104-Express™	ASP-129637-13	ASP-129646-22	1	15.24 mm
PCI/104-Express™	ASP-142781-01	ASP-129646-01	1	22 mm
PCI/104-Express™	ASP-142781-02	ASP-129646-02	2	22 mm
PCI/104-Express™	ASP-142781-03	ASP-129646-03	3	22 mm

BOARD STACKER	A	BOARD STACK HEIGHT
-0515	(5.15) .203	5 mm
-0715	(7.15) .282	7 mm
-0815	(8.15) .321	8 mm
-0865	(8.65) .341	8.5 mm
-1115	(11.15) .439	11 mm
-1215	(12.15) .478	12 mm
-1524	(15.24) .600	15.09 mm
-1615	(16.15) .636	16 mm
-1890	(18.90) .744	18.75 mm
-1915	(19.15) .754	19 mm
-2515	(25.15) .990	25 mm

ALSO AVAILABLE

MOQ Required

Other heights
Stainless Steel
Locking compound removed
Other materials and threading
No Hardware

Notes:
Standoffs are designed,
0.15 mm longer than
connector stack heights to
allow for processing variables.

Some sizes, styles and
options are non-standard,
non-returnable.

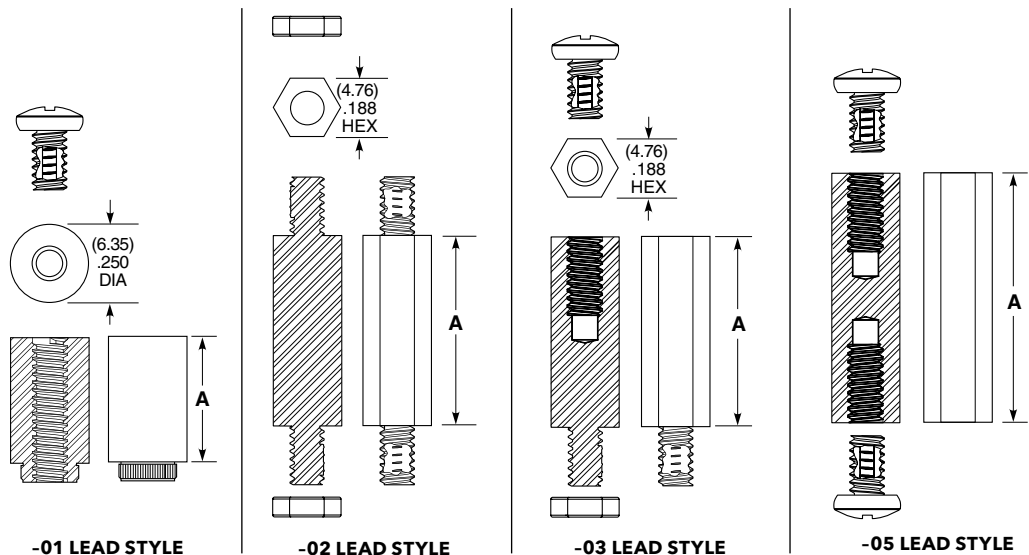

Components are to be packaged in separate bags unassembled.

HIGH-SPEED EDGE CARD SYSTEMS

SPEEDS TO 56 Gbps • RUGGED EDGE RATE® CONTACTS • VARIETY OF OPTIONS

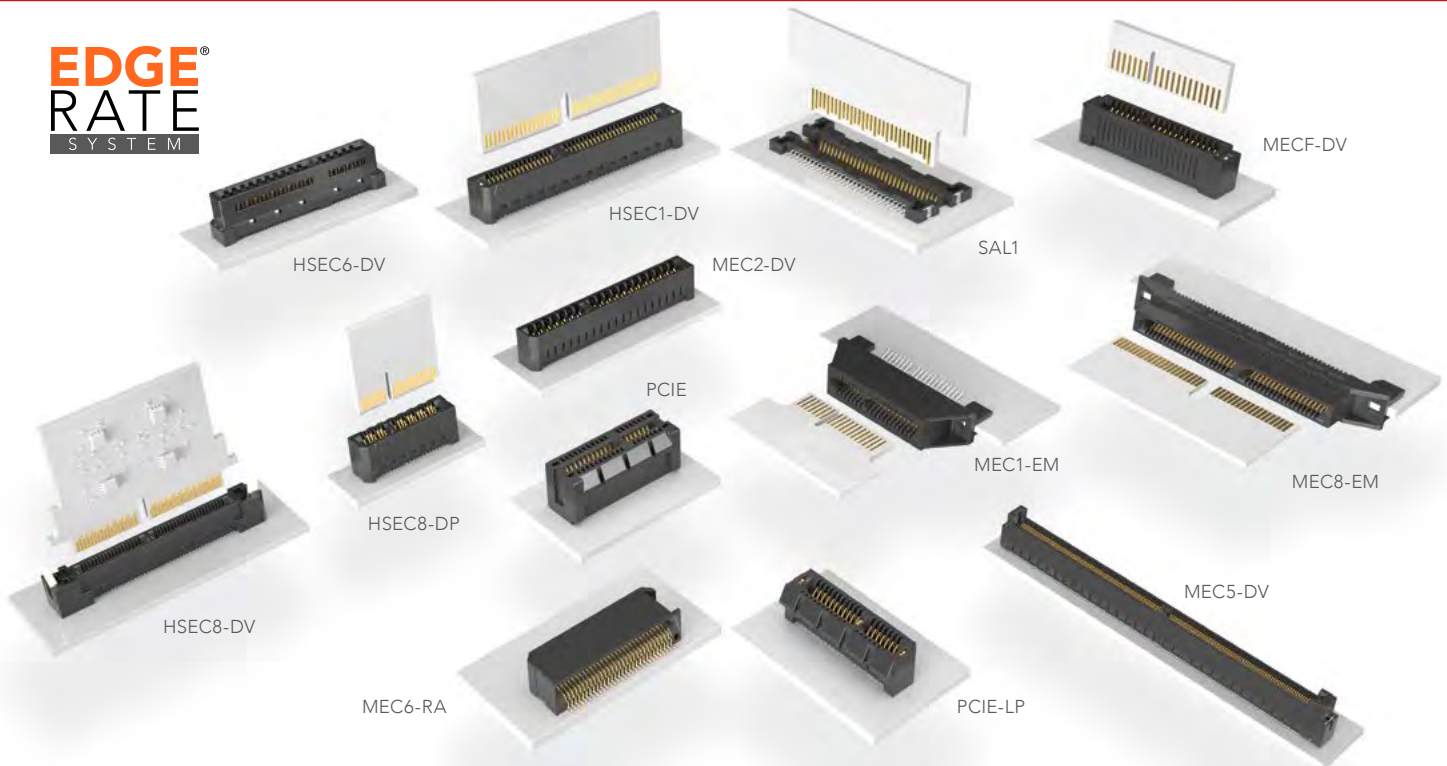

64-71

HIGH-SPEED EDGE CARD INTERCONNECTS

0.60 mm Pitch Edge Rate® Socket (HSEC6)	65
0.80 mm Pitch Rugged Edge Card Socket (HSEC8)	66
0.80 mm Pitch Edge Rate® Socket (HSEC8)	67-70
1.00 mm Pitch Edge Rate® Socket (HSEC1)	71

72-79

MICRO/MINI EDGE CARD INTERCONNECTS

0.50 mm Pitch Micro Socket (MEC5)	73
0.635 mm Pitch Micro Socket (MEC6)	74
0.80 mm Pitch Micro Edge Socket (MEC8)	75-76
1.00 mm Pitch Mini Edge Card Socket (MEC1)	77-78
1.27 mm Pitch Mini Edge Card Socket (MECF)	79
2.00 mm Pitch Mini Edge Card Socket (MEC2)	79

80-83

PCI EXPRESS® INTERCONNECTS

PCI Express® & Low-Profile PCI Express® Sockets (PCIE)	81
PCI Express® 4.0 & 5.0 Sockets (PCIE-G4 & PCIE-G5)	82
1.00 mm Pitch High-Speed Through Board Socket (SAL1)	83

HIGH-SPEED EDGE CARD SYSTEMS

0.60 mm, 0.80 mm and 1.00 mm PITCH

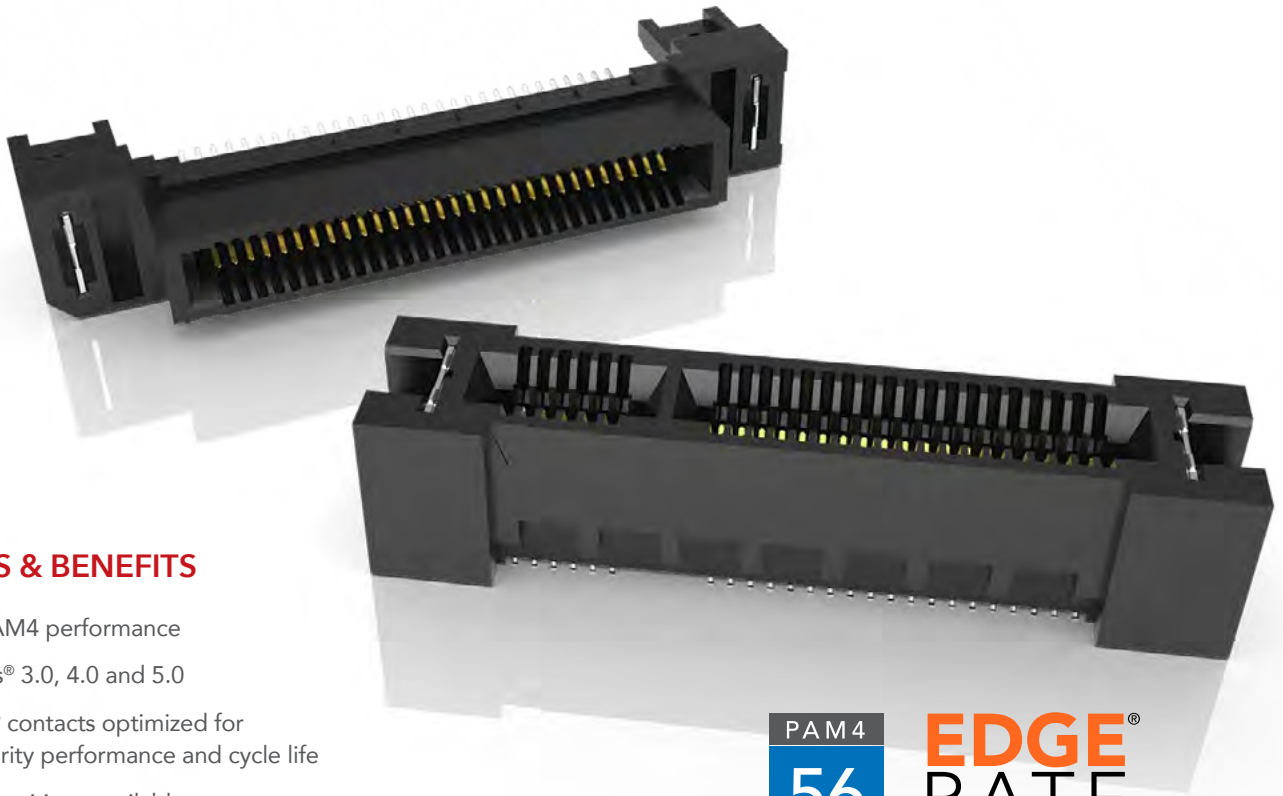

FEATURES & BENEFITS

- 56 Gbps PAM4 performance
- PCI Express® 3.0, 4.0 and 5.0
- Edge Rate® contacts optimized for signal integrity performance and cycle life
- Up to 200 positions available
- Vertical, right-angle, edge mount, pass-through orientations
- Power/signal combo, press-fit tails, rugged weld tabs, locks and latches
- Mating cable assemblies available

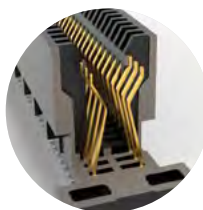
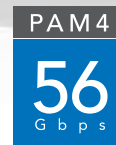

Rugged tucked beam technology (HTEC8)



Differential pair for increased speed (HSEC8-DP)



Custom designs allow for misalignment in the X-Y axes (HSEC1)

KEY SPECIFICATIONS

SERIES	PITCH	TOTAL POSITIONS	INSULATOR MATERIAL	CONTACT MATERIAL	OPERATING TEMP RANGE	CURRENT RATING	VOLTAGE RATING	LEAD-FREE SOLDERABLE
HSEC6	0.60 mm	56-168	Black LCP	Copper Alloy	-55 °C to +125 °C	0.8 A (12 pins)	300 VAC	Yes
HTEC8	0.80 mm	40-200	Black LCP	Copper Alloy	-55 °C to +125 °C	3.0 A (2 pins)	215 VAC	Yes
HSEC8	0.80 mm	18-200	Black LCP	BeCu	-55 °C to +125 °C	2.8 A (2 pins)	240 VAC	Yes
HSEC1	1.00 mm	20-140	Black LCP	Phosphor Bronze	-55 °C to +125 °C	2.2 A (2 pins)	215 VAC	Yes

(0.60 mm) .024" PITCH • VERTICAL EDGE CARD SOCKET

HSEC6	POSITIONS PER ROW	CARD THICKNESS	PLATING OPTION	DV	SHIELD OPTION	WT	"X" R
	-028, -042, -070, -084	-01 = (1.60 mm) .062" thick card	-L = 10 μ" (0.25 μm) Gold on contact area, Matte Tin on tail -S = 30 μ" (0.76 μm) Gold on contact area, Matte Tin on tail		Leave blank for no shield -S = Shield	-WT = Middle Weld tab (not available with -028 positions)	-TR = Tape & Reel -FR = Full Reel Tape & Reel (must order max. quantity per reel; contact Samtec for quantity breaks)

PRELIMINARY

HSEC6
Card Mates:
(1.60 mm)
.062" card

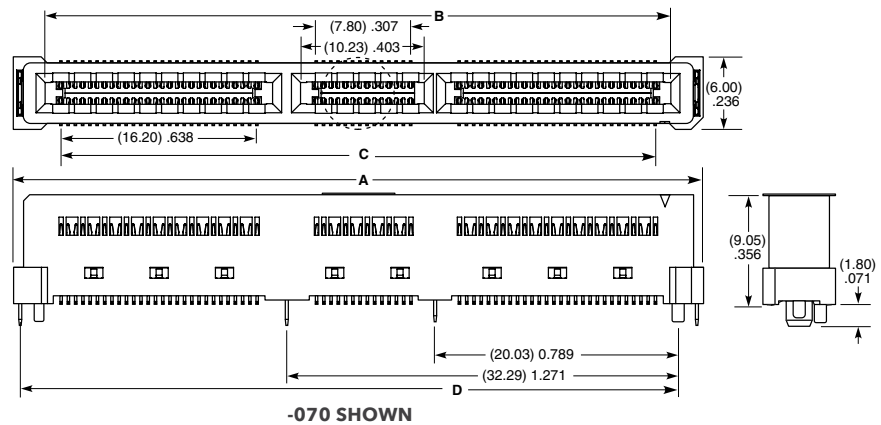
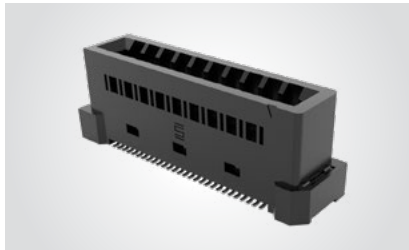

STANDARDS

SFF-TA-1002
Visit www.samtec.com/standards for more information.

HIGH-SPEED PAIRS	SFF-TA-1002	POSITIONS PER ROW	A	B	C	D
x4, 8 DP's	1C	-028	(23.88) .940	(18.62) .733	(16.20) .638	(21.18) .834
x8, 16 DP's	2C	-042	(35.60) 1.402	(30.61) 1.205	(28.01) 1.103	(32.90) 2.295
x16, 32 DP's	4C	-070	(57.02) 2.245	(51.72) 2.036	(49.12) 1.934	(54.32) 2.139
	4C+	-084	(69.17) 2.723	(63.92) 2.516	(61.32) 2.414	(66.52) 2.619

Note:
Polyimide film pick & place pad is standard.

Some sizes, styles and options are non-standard, non-returnable

View complete specifications at: samtec.com?HSEC6-DV

(0.80 mm) .0315" PITCH • RUGGED HIGH-SPEED EDGE CARD SOCKET

HTEC8	1	POSITIONS PER ROW	01	PLATING OPTION	DV	OPTION	OTHER OPTIONS
		20, 30, 40, 50, 60, 80, 100		-L = 10 μ" (0.25 μm) Gold on contact area, Matte Tin on tail -S = 30 μ" (0.76 μm) Gold on contact area, Matte Tin on tail		Leave blank for no alignment pin -A = Alignment Pin -WT = Weld Tab (-A option required)	-K = (7.00 mm) .276" DIA Polyimide Pick & Place Pad -TR = Tape & Reel (20 thru 60 positions only) (Leave blank for tray) -FR = Full Reel Tape & Reel (must order max. quantity per reel; contact Samtec for quantity breaks) (20 thru 60 positions only) (Leave blank for tray)

HTEC8
Card Mates:
(1.60 mm) .062" thick card

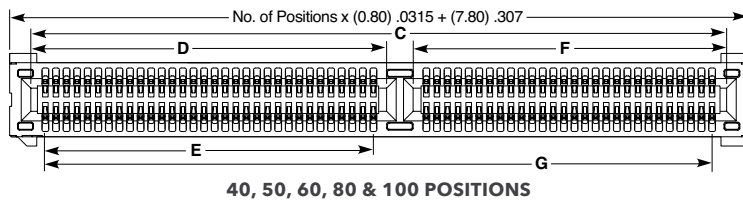

POSITIONS PER ROW	C	D	E	F	G
40	(36.60) 1.440	(18.90) .744	(16.80) .661	(15.70) .618	(34.40) 1.354
50	(44.60) 1.756	(22.90) .902	(20.80) .819	(19.70) .776	(42.40) 1.669
60	(52.60) 2.071	(26.90) 1.059	(24.80) .976	(23.70) .933	(50.40) 1.984
80	(68.60) 2.701	(26.90) 1.059	(24.80) .976	(39.70) 1.563	(66.40) 2.614
100	(84.60) 3.331	(26.90) 1.059	(24.80) .976	(55.70) 2.193	(82.40) 3.244

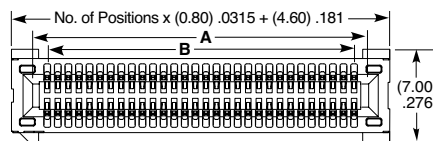

POSITIONS PER ROW	A	B
20	(17.40) .685	(15.20) 5.98
30	(25.40) 1.000	(23.20) .913

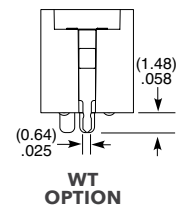
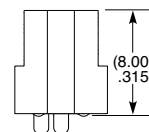
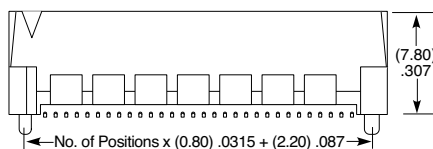

Note:
Some sizes, styles and options are non-standard, non-returnable.

View complete specifications at: samtec.com?HTEC8

(0.80 mm) .0315" PITCH • VERTICAL EDGE CARD SOCKET

HSEC8	- 1	POSITIONS PER ROW	CARD THICKNESS	PLATING OPTION	DV	A	OTHER OPTIONS
--------------	------------	--------------------------	-----------------------	-----------------------	-----------	----------	----------------------

09, 10, 13, 20, 25, 30, 37, 40, 49, 50, 60, 70, 80, 100
(13, 25, 49 only available with -L or -L2 option; 09 only available with -L2 option; 37 only available with -L option)

-01
= (1.60 mm) .062" thick card

-03
= (2.36 mm) .093" thick card

-L
= 10 μ" (0.25 μm) Gold on contact area, Matte Tin on tail

-S
= 30 μ" (0.76 μm) Gold on contact area, Matte Tin on tail

-K
= Polyimide Pick & Place Pad

-BL
= Board Locks; -01 card only (Weld tab standard)

-L
= Latching Option; -01 card only (13, 25, 37, 49 only) (Weld tab standard)

-L2
= ECDP Latching; -01 card only (09, 13, 25, 49 only) (For use with ECDP) (Weld tab standard)

-WT
= Weld tab

-TR
= Tape & Reel (09 - 70 only)

-FR
= Full Reel Tape & Reel (must order max. quantities per reel; contact Samtec for quantity breaks) (09-70 only)

HSEC8-DV

Card Mates:
(1.60 mm) .062" card
(2.36 mm) .093" card
HSC8

Cable Mates:
ECDP

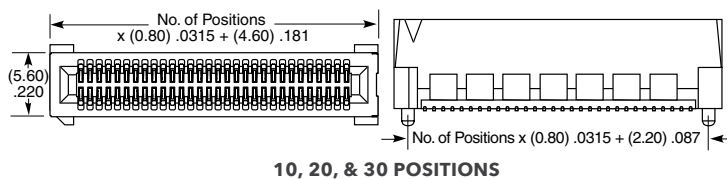
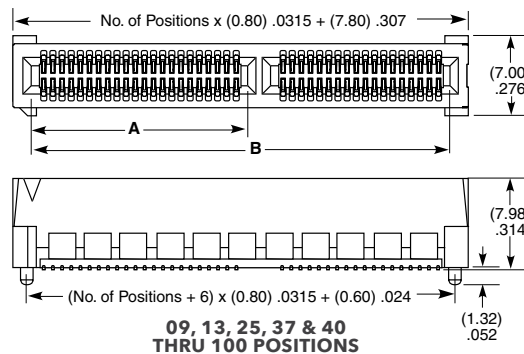

OTHER SOLUTIONS

For complete edge card system with cards and sockets, visit samtec.com?RU8.

For a card to mate with an HSEC8 socket, visit samtec.com?HSC8



POSITIONS PER ROW	A	B	CABLE	CONNECTOR
09*†	(4.50) .177	(11.80) .465	ECDP-04	HSEC8-109-L2
13*†	(6.10) .240	(15.00) .591	ECDP-08	HSEC8-113-L2
25*†	(6.10) .240	(24.60) .969	ECDP-16	HSEC8-125-L2
37†	(18.10) .713	(34.20) 1.346	ECDP-32	HSEC8-149-L2
40	(18.90) .744	(36.60) 1.441		
49*†	(22.90) .902	(43.80) 1.724		
50	(22.90) .902	(44.60) 1.756		
60	(26.90) 1.059	(52.60) 2.071		
70†	(26.90) 1.059	(60.60) 2.386		
80†	(26.90) 1.059	(68.60) 2.701		
100†	(26.90) 1.059	(84.60) 3.331		

Positions where no dimensions are given do not have keying feature.

* Mates with ECDP Series
† Available with -01 Card Only

Note:
Some sizes, styles and options are non-standard, non-returnable.

View complete specifications at: samtec.com?HSEC8-DV

(0.80 mm) .0315" PITCH • RIGHT-ANGLE & EDGE MOUNT SOCKET

HSEC8	1	POSITIONS PER ROW	CARD THICKNESS	PLATING OPTION	RA	OTHER OPTIONS	"X"R
--------------	----------	--------------------------	-----------------------	-----------------------	-----------	----------------------	-------------

09, 10, 13, 20,
25, 30, 40, 49,
50, 60

-01
= (1.60 mm) .062"
thick card

-L
= 10 μ" (0.25 μm)
Gold on contact area,
Matte Tin on tail

-S
= 30 μ" (0.76 μm)
Gold on contact area,
Matte Tin on tail

-BL
= Board Locks (09, 13,
25, 40, 49, 50, 60 only)

-L2
= ECDP Latching
(09, 13, 25, 49 only)

Leave blank for
Tray Packaging

-TR
= Tape & Reel

-FR
= Full Reel
Tape & Reel Packaging
(must order max.
quantity per reel;
contact Samtec for
quantity breaks)

HSEC8-RA

Card Mates:
(1.60 mm) .062"
thick card,
HSC8

Cable Mates:
ECDP



POSITIONS PER ROW	A	B	C
40	(43.80) 1.724	(18.90) .744	(36.60) 1.441
50	(51.80) 2.039	(22.90) .902	(44.60) 1.756
60	(59.80) 2.354	(26.90) 1.059	(52.60) 2.071
40-BL	(51.30) 2.020	(18.90) .744	(36.60) 1.441
50-BL	(59.30) 2.335	(22.90) .902	(44.60) 1.756
60-BL	(67.30) 2.650	(26.90) 1.059	(52.60) 2.071

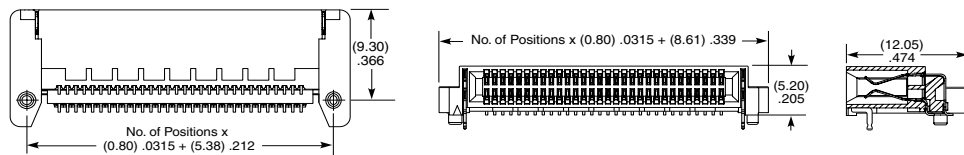
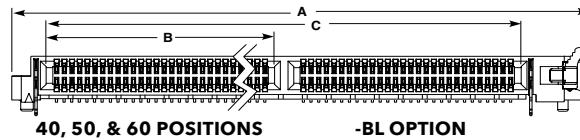

View complete specifications at: samtec.com?HSEC8-RA

HSEC8	1	POSITIONS PER ROW	01	PLATING OPTION	D	EM2
--------------	----------	--------------------------	-----------	-----------------------	----------	------------

10, 20, 30, 40,
50, 60

-L
= 10 μ" (0.25 μm)
Gold on contact area,
Matte Tin on tail

-S
= 30 μ" (0.76 μm)
Gold on contact area,
Matte Tin on tail

-EM2
=(1.60 mm) .062"
thick PCB

HSEC8-EM

Card Mates:
(1.60 mm) .062"
thick card,
HSC8

Cable Mates:
ECDP

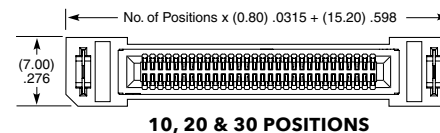
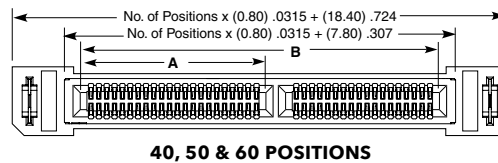

POSITIONS PER ROW	A	B
40	(18.90) .744	(36.60) 1.441
50	(22.90) .902	(44.60) 1.756
60	(26.90) 1.059	(52.60) 2.071

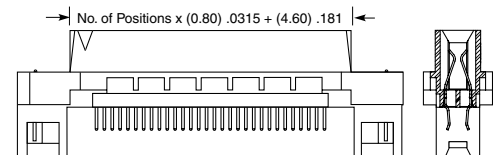

Note:
Some sizes, styles and
options are non-standard,
non-returnable.

View complete specifications at: samtec.com?HSEC8-EM

(0.80 mm) .0315" PITCH • PASS-THROUGH & POWER COMBO

HSEC8	1	POSITIONS PER ROW	CARD THICKNESS	PLATING OPTION	DV	A	PE	OTHER OPTIONS
--------------	----------	--------------------------	-----------------------	-----------------------	-----------	----------	-----------	----------------------

10, 13, 20

-01
= (1.60 mm) .062" thick card

-L
= 10 μ" (0.25 μm)
Gold on contact area, Matte Tin on tail

-S
= 30 μ" (0.76 μm)
Gold on contact area, Matte Tin on tail

-K
= (5.50 mm) .217" DIA
Polyimide Film Pick & Place Pad

-TR
=Tape & Reel Packaging

-FR
= Full Reel Tape & Reel Packaging (Must order max. quantities per reel. Contact Samtec for parts per reel)

HSEC8-PE

Card Mates:
(1.60 mm) .062" thick card, HSC8

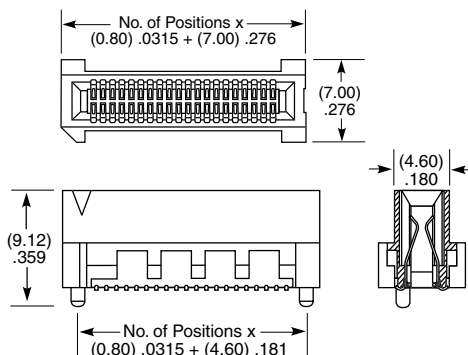

View complete specifications at: samtec.com?HSEC8-DV

HSEC8	1	SIGNAL POSITIONS	CARD THICKNESS	PLATING OPTION	PV	POWER POSITIONS	POWER TAIL	OTHER OPTION
--------------	----------	-------------------------	-----------------------	-----------------------	-----------	------------------------	-------------------	---------------------

20, 30, 40
(Signal positions per row)

-01
= (1.60 mm) .062" thick card

-L
= 10 μ" (0.25 μm)
Gold on contact area, Matte Tin on tail

-S
= 30 μ" (0.76 μm)
Gold on contact area, Matte Tin on tail

-2, -4
(Total, 2 per power bank)

-1
= Use with (1.60 mm) .062" Thick PCB

-2
= Use with (2.36 mm) .093" Thick PCB

-WT
= Weld Tab

HSEC8-PV

Card Mates:
(1.60 mm) .062" thick card

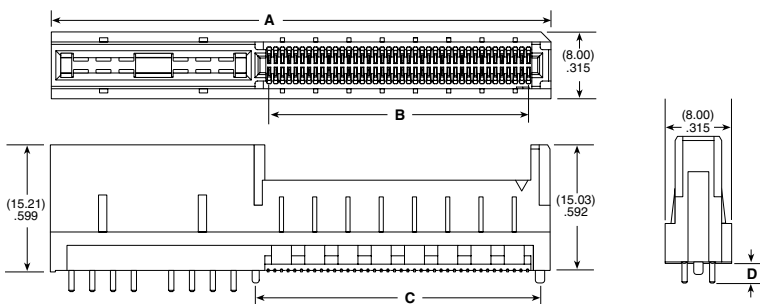

SIGNAL POSITIONS	POWER POSITIONS						POWER TAIL	D
	A (-2)	B (-2)	C (-2)	A (-4)	B (-4)	C (-4)		
20	(32.10) 1.264	(15.20) .598	(18.20) .717	(44.10) 1.736	(15.20) .598	(18.20) .717	-1	(2.35) .093
30	(40.10) 1.579	(23.20) .913	(26.20) 1.031	(52.10) 2.051	(23.20) .913	(26.20) 1.031	-2	(3.13) .123
40	(48.10) 1.894	(31.20) 1.228	(34.20) 1.346	(60.10) 2.366	(31.20) 1.228	(34.20) 1.346		

Note:
Some sizes, styles and options are non-standard, non-returnable.

View complete specifications at: samtec.com?HSEC8-PV

0.80 mm (.0315") PITCH • DIFFERENTIAL PAIR EDGE CARD

HSEC8	1	NUMBER OF PAIRS	01	PLATING OPTION	DP	A	OPTION	K	"X"R
		08, 12, 16, 20, 32, 56 (Total Pairs)		-L = 10 μ" (0.25 μm) Gold on contact area, Matte Tin on tail			Leave blank for weld tab -WT = Weld Tab	-K = (6.25 mm) .246" DIA Polyimide Film Pick & Place Pad	Leave blank for Tape & Reel -FR = Full Reel Tape & Reel (must order max. quantity per reel; contact Samtec for quantity breaks)

HSEC8-DP
Card Mates:
(1.60 mm) .062"
thick card

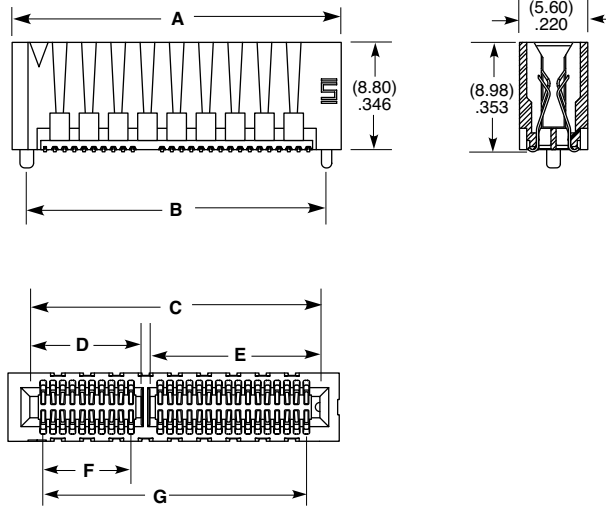

NUMBER OF PAIRS	A	B	C	D	E	F	G
08	(17.40) .685	(15.00) .591	(14.20) .559	(4.34) .171	(9.14) .360	(2.40) .094	(12.00) .472
12	(22.20) .874	(19.80) .780	(19.00) .748	(6.74) .265	(11.54) .454	(4.80) .189	(16.80) .661
16	(27.00) 1.063	(24.60) .969	(23.80) .937	(9.14) .360	(13.94) .549	(7.20) .283	(21.60) .850
20	(31.80) 1.252	(29.40) 1.157	(28.60) 1.126	(11.54) .454	(16.34) .643	(9.60) .378	(26.40) 1.039
32	(46.20) 1.819	(43.80) 1.724	(43.00) 1.693	(18.74) .738	(23.54) .927	(16.80) .661	(40.80) 1.606
56	(75.00) 2.953	(72.60) 2.858	(71.80) 2.827	(33.14) 1.305	(37.94) 1.494	(31.20) 1.228	(69.60) 2.740

Note:
Some sizes, styles and
options are non-standard,
non-returnable.

View complete specifications at: samtec.com?HSEC8-DP

1.00 mm (.0394") PITCH • VERTICAL HIGH-SPEED EDGE CARD

HSEC1	POSITIONS PER ROW	CARD THICKNESS	PLATING OPTION	DV	OPTION	OTHER OPTIONS
	-010, -020, -030, -040, -050, -060, -070	-01 =(1.60 mm) .062" thick card	-L = 10 μ" (0.25 μm) Gold on contact area, Matte Tin on tail -S = 30 μ" (0.76 μm) Gold on contact area, Matte Tin on tail		-A or -WT required in callout -A =Alignment Pin (Not available with -WT) -WT =Weld tab (Not available with -A)	-K =(7.01 mm) .276" DIA Polyimide Film Pick & Place Pad -TR =Tape & Reel (Required for 10-60 positions) -FR = Full Reel Tape & Reel (must order max. quantity per reel; contact Samtec for quantity breaks) (Required for 10-60 positions)

HSEC1-DV
Card Mates:
(1.60 mm) .062"
thick card

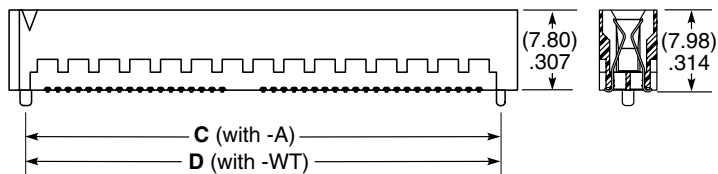
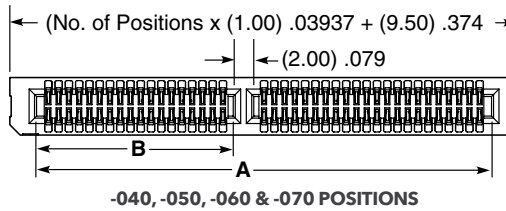
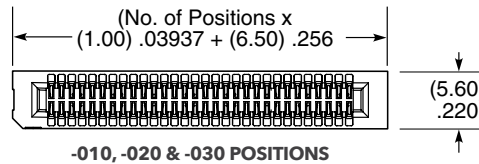
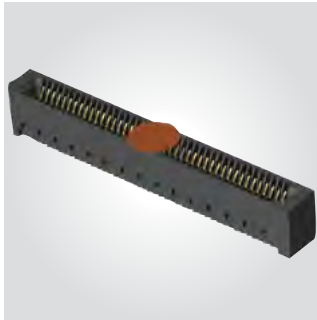

POSITIONS PER ROW	A	B	C (with -A)	D (with -WT)
-010	(11.30) .445	N/A	(13.25) .522	(14.50) .571
-020	(21.30) .839	N/A	(23.25) .915	(24.50) .965
-030	(31.30) 1.232	N/A	(33.25) 1.309	(34.50) 1.358
-040	(44.30) 1.744	(19.15) .754	(46.25) 1.821	(47.50) 1.870
-050	(54.30) 2.138	(24.15) .951	(56.25) 2.215	(57.50) 2.264
-060	(64.30) 2.531	(29.15) 1.148	(66.25) 2.608	(67.50) 2.657
-070	(74.30) 2.925	(34.15) 1.344	(76.25) 3.002	(77.50) 3.051

Note:
Some sizes, styles and
options are non-standard,
non-returnable.

View complete specifications at: samtec.com?HSEC1-DV

MICRO EDGE CARD SYSTEMS

0.50 mm, 0.635 mm, 0.80 mm, 1.00 mm, 1.27 mm, 2.00 mm PITCH

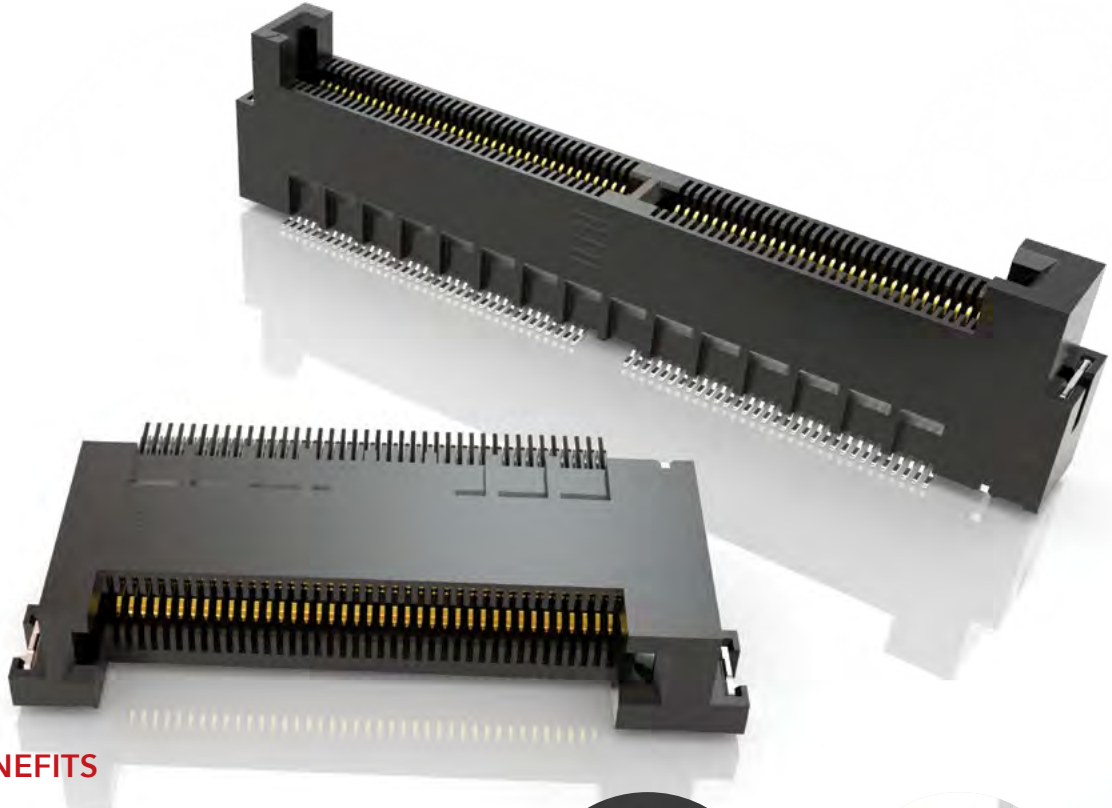

FEATURES & BENEFITS

- Up to 56 Gbps PAM4
- PCI Express® 4.0 (MEC5 Series)
- Solutions for .062" (1.60 mm), and .093" (2.36 mm) thick cards
- Choice of pitch: 0.50 mm, 0.635 mm, 0.80 mm, 1.00 mm, 1.27 mm, 2.00 mm
- Vertical, right-angle, edge mount
- Available in surface mount and through-hole

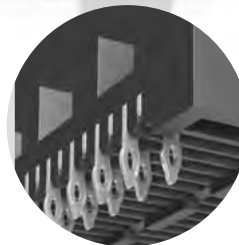

Staggered press-fit tails
(MEC8-VP)



Justification beam ensures
card and body are flushed
(MEC5)

KEY SPECIFICATIONS

SERIES	PITCH	TOTAL POSITIONS	INSULATOR MATERIAL	CONTACT MATERIAL	OPERATING TEMP RANGE	CURRENT RATING	VOLTAGE RATING	LEAD-FREE SOLDERABLE
MEC5	0.50 mm	60-200	Black LCP	Phosphor Bronze	-55 °C to +125 °C	1.5 A (2 pins)	125 VAC	Yes
MEC6	0.635 mm	20-140	Black LCP	Phosphor Bronze	-55 °C to +125 °C	2.4 A (2 pins)	195 VAC	Yes
MEC8	0.80 mm	20-140	Black LCP	Phosphor Bronze	-55 °C to +125 °C	1.8 A (4 pins)	185 VAC	Yes
MEC1	1.00 mm	20-140	Black LCP	Phosphor Bronze	-55 °C to +125 °C	2.2 A (2 pins)	250 VAC	Yes
MECF	1.27 mm	10-100	Black/Natural LCP	BeCu	-55 °C to +125 °C	3.5 A (2 pins)	280 VAC	Yes
MEC2	2.00 mm	10-100	Black/Natural LCP	BeCu	-55 °C to +125 °C	3.5 A (2 pins)	238 VAC	Yes

(0.50 mm) .0197" PITCH • MICRO EDGE CARD SOCKET

MEC5	POSITIONS PER ROW	01	PLATING OPTION	TAIL OPTION	WELD TAB OPTION	OTHER OPTION	"X"R
	-030, -040, -050, -060, -070, -080 (-RA & -DV) -090, -100 (-DV only)		-L =10 μ" (0.25 μm) Gold on contact, Matte Tin on tail	-DV Vertical -RA Right-angle	-W1 = Weld Tab Through-hole (Required for -DV option) -W2 = Weld Tab Surface Mount (Not available for -DV)	-K = Polyimide Pick & Place Pad (Required for -DV) (Not available in -RA)	Leave blank for Tray Packaging -TR = Tape & Reel -FR = Full Reel Tape & Reel (must order max. quantity per reel; contact Samtec for quantity breaks)

MEC5-DV

Card Mates:
(1.60 mm) .062" thick card with standard board tolerance

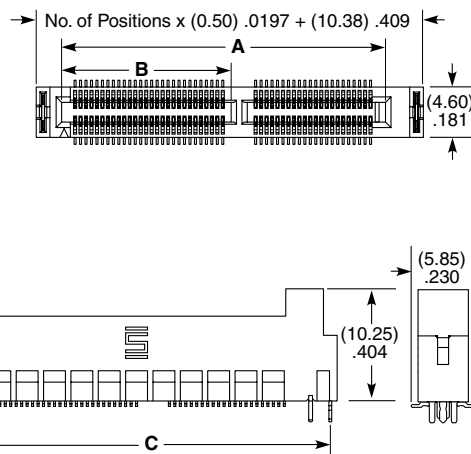
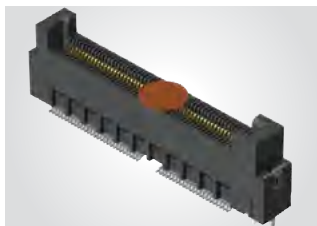

POSITIONS PER ROW	A	B	C
-030	(17.10) .673	N/A	(21.63) .852
-040	(22.10) .870	N/A	(26.63) 1.048
-050	(29.60) 1.165	(15.48) .609	(34.13) 1.344
-060	(34.60) 1.362	(17.98) .708	(39.13) 1.541
-070	(39.60) 1.559	(20.48) .806	(44.13) 1.737
-080	(44.60) 1.756	(22.98) .905	(49.13) 1.934
-090	(49.60) 1.953	(25.48) 1.003	(54.13) 2.131
-100	(54.60) 2.150	(27.98) 1.102	(59.13) 2.328

Note: Polarization rib is not present on -030 & -040 positions

View complete specifications at: samtec.com?MEC5-DV

MEC5-RA

Card Mates:
(1.60 mm) .062" thick card with standard board tolerance

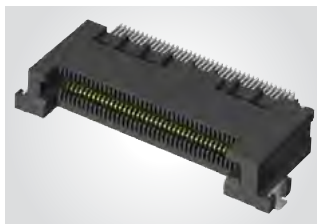

POSITIONS PER ROW	A	B	C	D
-30	(23.38) .920	(17.10) .673	N/A	(18.16) .715
-40	(28.38) 1.117	(22.10) .870	N/A	(23.16) .912
-50	(35.88) 1.413	(29.60) 1.165	(15.44) .608	(30.66) 1.207
-60	(40.88) 1.609	(34.60) 1.362	(17.94) .706	(35.66) 1.404
-70	(45.88) 1.806	(39.60) 1.559	(20.44) .805	(40.66) 1.601
-80	(50.88) 2.003	(44.60) 1.756	(22.94) .903	(45.66) 1.798

Note: Polarization rib is not present on -030 & -040 positions

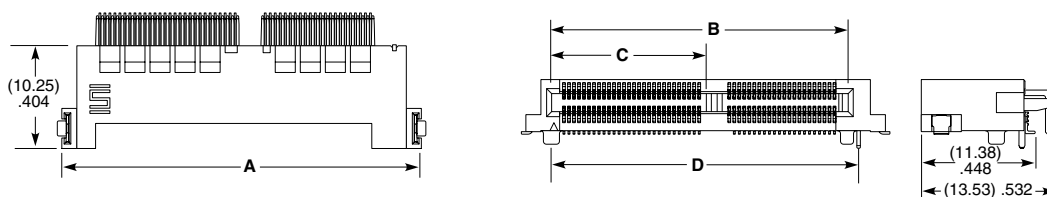

Note:
Some sizes, styles and options are non-standard, non-returnable.

View complete specifications at: samtec.com?MEC5-RA

(0.635 mm) .025" PITCH • VERTICAL AND RIGHT-ANGLE EDGE CARD SOCKET

MEC6 - **1** POSITIONS PER ROW - **02** PLATING OPTION - **DV** - **A** - **OPTION** - **"X"R**

10, 20, 30, 40,
50, 60, 70

-L
= 10 μ" (0.25 μm)
Gold on contact,
Matte Tin on tail

-K
= (5.50 mm) 2.17" DIA
Polyimide Pick
& Place Pad

Leave blank
for Tray Packaging

-TR
= Tape & Reel

-FR
= Full Reel
Tape & Reel
(must order max.
quantity per reel;
contact Samtec for
quantity breaks)

MEC6-DV

Card Mates:
(1.60 mm) .062"
thick card



POSITIONS PER ROW	A	B
50	(21.06) .829	(36.49) 1.437
60	(24.87) .979	(42.84) 1.687
70	(28.68) 1.129	(49.19) 1.937

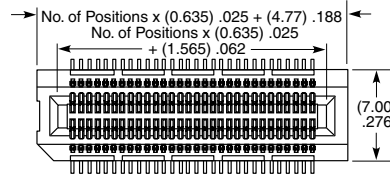

10, 20, 30 & 40 POSITIONS

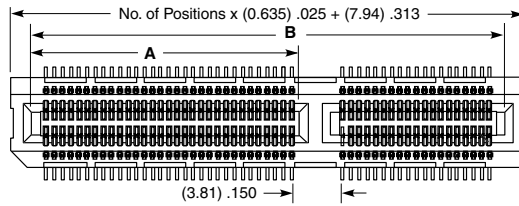

50, 60 & 70 POSITIONS

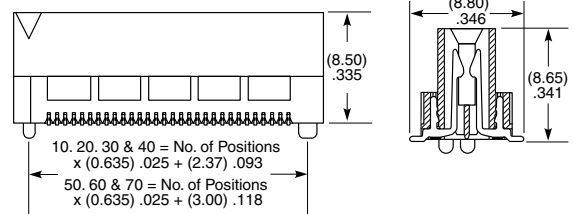

View complete specifications at: samtec.com?MEC6-DV

MEC6 - **1** POSITIONS PER ROW - **02** PLATING OPTION - **D** - **TAIL** - **OPTIONS**

10, 20, 30,
40, 50

-L
= 10 μ" (0.25 μm)
Gold on contact,
Matte Tin on tail

-RA1
= Right angle

-TR
= Tape & Reel

-FR
= Full Reel Tape & Reel
(must order max. quantity
per reel; contact Samtec
for quantity breaks)

MEC6-RA

Card Mates:
(1.60 mm) .062"
thick card

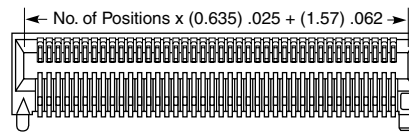

10, 20, 30 & 40 POSITIONS

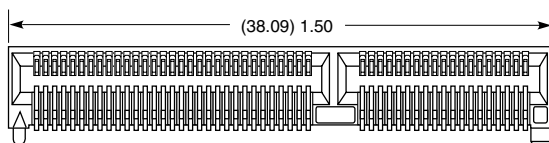

50 POSITIONS

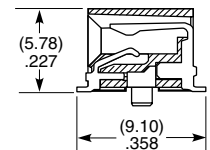
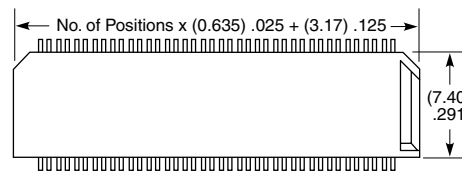

Note:
Some sizes, styles and
options are non-standard,
non-returnable.

View complete specifications at: samtec.com?MEC6-RA

(0.80 mm) .0315" PITCH • VERTICAL AND PRESS-FIT EDGE CARD SOCKET

MEC8 - **1** **POSITIONS PER ROW** - **02** - **PLATING OPTION** - **DV** - **OTHER OPTIONS** - **"X"R**

10, 20, 30, 40,
50, 60, 70

-L
= 10 μ" (0.25 μm)
Gold on contact,
Matte Tin on tail

-A
= Alignment Pin

-K
= (5.50 mm) 2.17" DIA
Polyimide Pick
& Place Pad

Leave blank for
Tray Packaging

-TR
= Tape & Reel

-FR
= Full Reel
Tape & Reel
(must order max.
quantity per reel;
contact Samtec for
quantity breaks)

MEC8-DV

Card Mates:
(1.60 mm) .062"
thick card



POSITIONS PER ROW	A	B
40	(18.90) .744	(36.60) 1.441
50	(22.90) .902	(44.60) 1.756
60	(26.90) 1.059	(52.60) 2.071
70	(30.90) 1.217	(60.60) 2.386

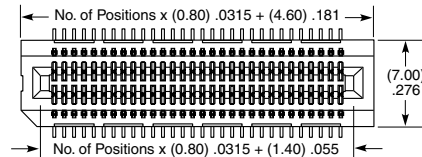

10, 20, & 30 POSITIONS

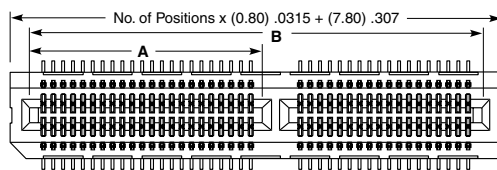

40, 50, 60 & 70 POSITIONS

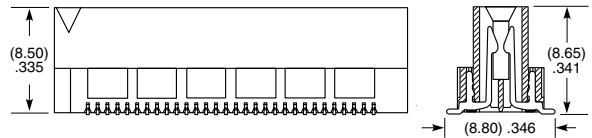

View complete specifications at: samtec.com?MEC8-DV

MEC8 - **1** **POSITIONS PER ROW** - **CARD THICKNESS** - **PLATING OPTION** - **TAIL**

10, 20, 30, 40

-02
= (1.60 mm) .062"
thick card

-L
= 10 μ" (0.25 μm)
Gold on contact,
Matte Tin on tail

-VP
= Press-fit

MEC8-VP

Card Mates:
(1.60 mm) .062"
thick card

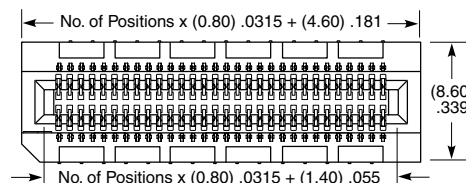
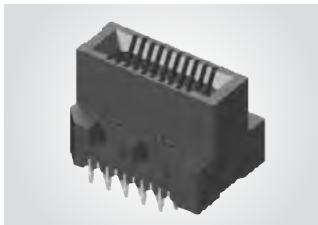

10, 20 & 30 POSITIONS

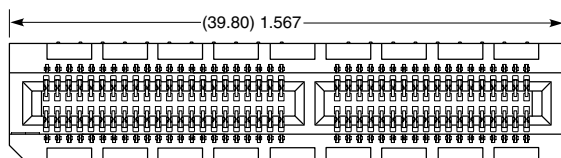

40 POSITIONS

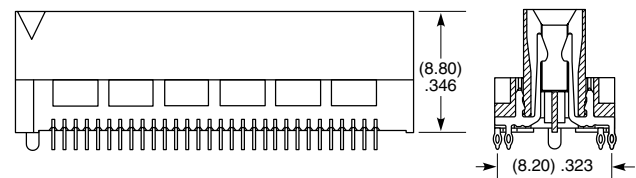

Note:
Some sizes, styles and
options are non-standard,
non-returnable.

View complete specifications at: samtec.com?MEC8-VP

(0.80 mm) .0315" PITCH • RIGHT-ANGLE/EDGE MOUNT EDGE CARD SOCKET

MEC8 - **1** POSITIONS PER ROW - **02** - **PLATING OPTION** - **D** - **RA1** - **"X"R**

10, 13, 20, 25, 30, 37, 40, 49, 50

-L
= 10 μ" (0.25 μm)
Gold on contact,
Matte Tin on tail

Leave blank for Tray Packaging

-TR
= Tape & Reel

-FR
= Full Reel
Tape & Reel
(must order max. quantity per reel; contact Samtec for quantity breaks)

MEC8-RA1

Card Mates:
(1.60 mm) .062" thick card

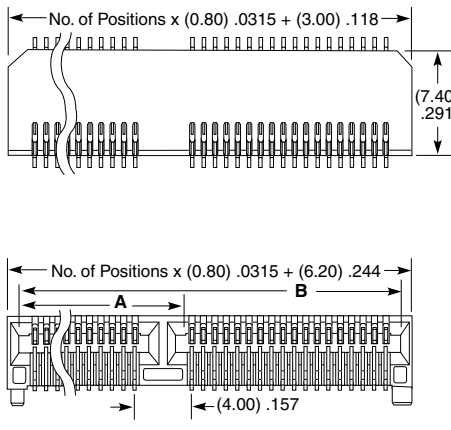
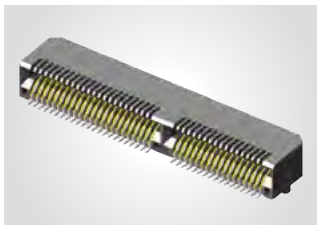

POSITIONS PER ROW	A	B
13	(6.10) .240	(15.00) .591
25		(24.60) .969
37	(18.10) .713	(34.20) 1.346
40	(18.90) .744	(36.60) 1.441
49	(22.90) .902	(43.80) 1.724
50		(44.60) 1.756

View complete specifications at: samtec.com?MEC8-RA

MEC8 - **1** POSITIONS PER ROW - **02** - **PLATING OPTION** - **D** - **EM2**

10, 20, 30, 40, 50, 60, 70

-L
= 10 μ" (0.25 μm)
Gold on contact,
Matte Tin on tail

MEC8-EM

Card Mates:
(1.60 mm) .062" thick card

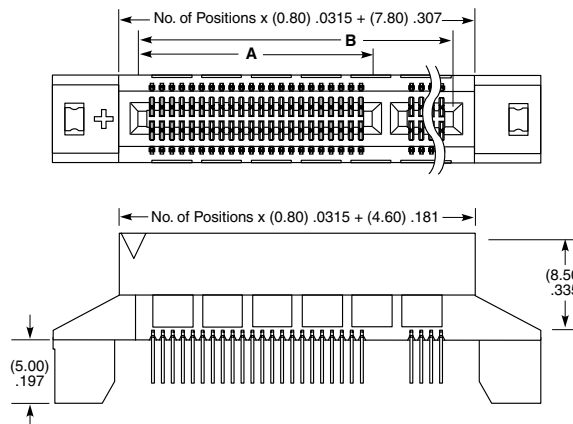
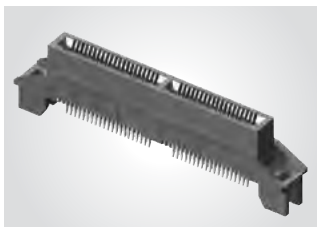

POSITIONS PER ROW	A	B
40	(18.90) .744	(36.60) 1.441
50	(22.90) .902	(44.60) 1.756
60	(26.90) 1.059	(52.60) 2.071
70	(30.90) 1.217	(60.60) 2.386

Note:
Some sizes, styles and options are non-standard, non-returnable.

View complete specifications at: samtec.com?MEC8-EM

(1.00 mm) .0394" PITCH • MINI EDGE CARD SOCKET

MEC1	1	POSITIONS PER ROW	02	PLATING OPTION	D	NP	OTHER OPTIONS
-------------	----------	--------------------------	-----------	-----------------------	----------	-----------	----------------------

05, 08, 20, 30, 40,
50, 60, 70

-F
= Gold flash on contact, Matte Tin on tail

-L
= 10 μ" (0.25 μm) Gold on contact, Matte Tin on tail

-NP
= No Polarization (05, 08, 20 & 30 positions only)

Leave blank for polarization

-A
= Alignment Pin metal or plastic at Samtec discretion

-K
= (7.87 mm) .310" DIA Polyimide film Pick & Place Pad

-TR
= Tape & Reel (05-60 only)

-FR
= Full Reel Tape & Reel (must order max. quantity per reel; contact Samtec for quantity breaks) (05-60 only)

MEC1

Card Mates:
(1.60 mm) .062" thick card

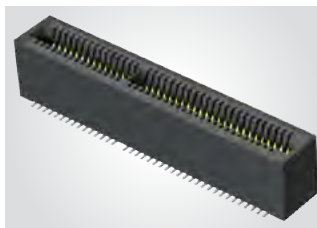

POSITIONS PER ROW	POLARIZED POSITIONS (No Contact)
05	3, 4
08	5, 6
20	15, 16
30	21, 22
40	31, 32
50	41, 42
60	31, 32, 63 & 64
70	53, 54, 115 & 116

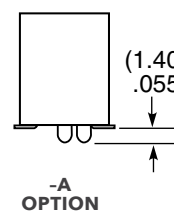
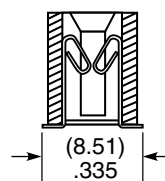
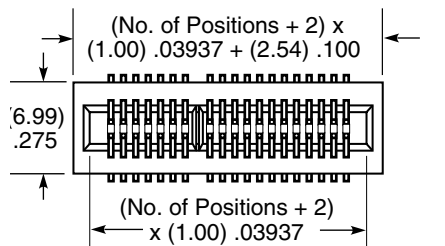

Note:
Some sizes, styles and options are non-standard, non-returnable.

View complete specifications at: samtec.com?MEC1

(1.00 mm) .0394" PITCH • RIGHT-ANGLE/EDGE MOUNT EDGE CARD SOCKET

MEC1	1	POSITIONS PER ROW	02	PLATING OPTION	D	RA1	NP	SL	"X"R
		05, 08, 20, 30, 40, 50, 60, 70		-F = Gold Flash on contact, Matte Tin on tail -L = 10 μ" (0.25 μm) Gold on contact, Matte Tin on tail			-NP = No Polarization (8 positions only) Leave blank for polarization		Leave blank for tubes -TR = Tape & Reel (not available with 70 positions) -FR = Full Reel Tape & Reel (must order max. quantity per reel; contact Samtec for quantity breaks) (not available with 70 positions)

MEC1-RA

Card Mates:
(1.60 mm) .062" thick card

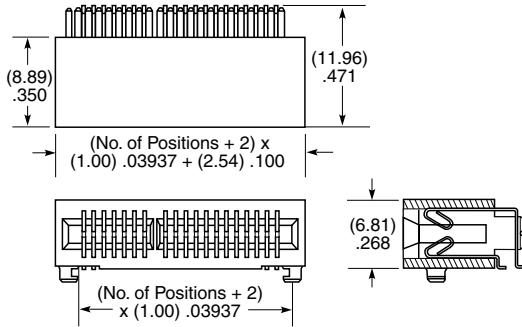
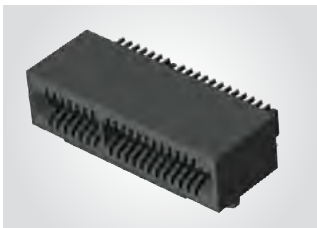

POSITIONS PER ROW	POLARIZED POSITIONS (No Contact)
05	3, 4
08	5, 6
20	15, 16
30	21, 22
40	31, 32
50	41, 42
60	31, 32, 63 & 64
70	53, 54, 115 & 116

View complete specifications at: samtec.com?MEC1-RA

MEC1	1	POSITIONS PER ROW	02	PLATING OPTION	D	EM2	NP	"X"R
		05, 08, 20, 30, 40, 50, 60, 70		-F = Gold Flash on contact, Matte Tin on tail -L = 10 μ" (0.25 μm) Gold on contact, Matte Tin on tail			-NP = No Polarization (8 positions only) Leave blank for polarization	Leave blank for Tray Packaging -TR = Tape & Reel (not available with 60 & 70 positions) -FR = Full Reel Tape & Reel (must order max. quantity per reel; contact Samtec for quantity breaks) (not available with 60 & 70 positions)

MEC1-EM

Card Mates:
(1.60 mm) .062" thick card

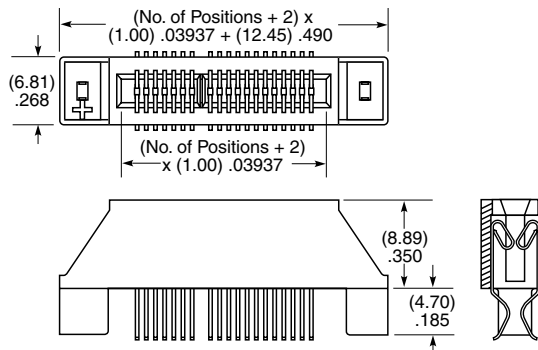
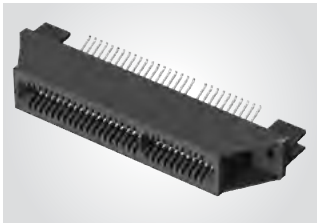

POSITIONS PER ROW	POLARIZED POSITIONS (No Contact)
05	3, 4
08	5, 6
20	15, 16
30	21, 22
40	31, 32
50	41, 42
60	31, 32, 63 & 64
70	53, 54, 115 & 116

Note:
Some sizes, styles and options are non-standard, non-returnable.

View complete specifications at: samtec.com?MEC1-EM

(1.27 mm) .050" PITCH • MINI EDGE CARD SOCKET

MECF	POSITIONS PER ROW	CARD THICKNESS	PLATING OPTION	DV	OPTION	"X"R
	-05, -08, -20, -30, -40, -50	-01 = (1.60 mm) .062" thick card -02 = (2.36 mm) .093" thick card	-L =10 μ" (0.25 μm) Gold on contact, Matte Tin on tail		-WT = Weld Tabs (Standard on -02 card thickness, optional on -01 card thickness) -K Polyimide film pick & place pad (-"X"R only)	Leave blank for tubes -TR = Tape & Reel -FR = Full ReelTape & Reel (must order max. quantity per reel; contact Samtec for quantity breaks)

MECF

Card Mates:
(1.60 mm) .062"
thick card
(2.36 mm) .093"
thick card

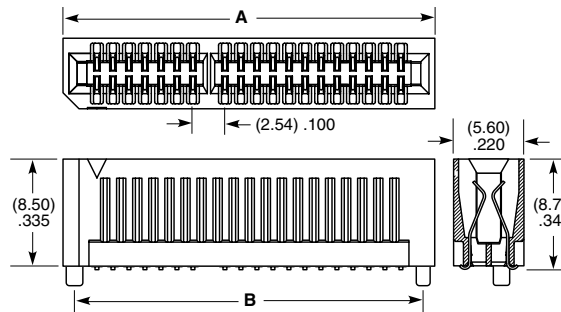

POSITIONS PER ROW	A	B
-05	(10.46) .412	(8.64) .340
-08	(14.27) .562	(12.45) .490
-20	(29.51) 1.162	(27.69) 1.090
-30	(42.21) 1.662	(40.39) 1.590
-40	(54.91) 2.162	(53.09) 2.090
-50	(67.61) 2.662	(65.79) 2.590

POSITIONS PER ROW	POLARIZED POSITIONS (No Contact)
-05	3, 4
-08	5, 6
-20	15, 16
-30	21, 22
-40	31, 32
-50	41, 42

View complete specifications at: samtec.com?MECF-DV

(2.00 mm) .0787" PITCH • MINI EDGE CARD SOCKET

MEC2	POSITIONS PER ROW	CARD THICKNESS	PLATING OPTION	TAIL OPTION	OPTION	"X"R
	-05, -08, -20, -30, -40, -50	-01 = (1.60 mm) .062" thick card -02 = (2.36 mm) .093" thick card (-DV option only)	-L =10 μ" (0.25 μm) Gold on contact, Matte Tin on tail	-DV Vertical Surface Mount -TH1 Through-hole	-WT = Weld Tabs (standard on -02 card, optional on -01 card) -K Polyimide film pick & place pad (-"X"R & -DV only)	Leave blank for tubes -TR = Tape & Reel (05 thru 30 positions only) (Not available with -TH1) -FR = Full Reel Tape & Reel (must order max. quantity per reel; contact Samtec for quantity breaks) (05 thru 30 positions only) (Not available with -TH1)

MEC2-DV

Card Mates:
(1.60 mm) .062"
thick card
(2.36 mm) .093"
thick card

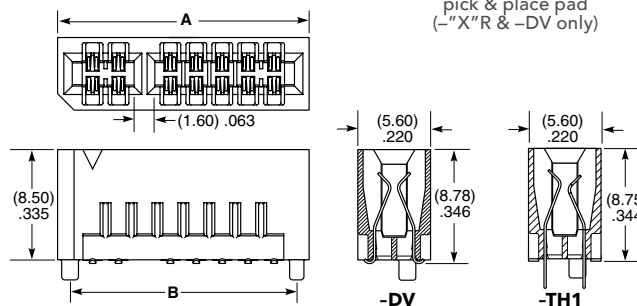

MEC2-TH

Card Mates:
(1.60 mm) .062"
thick card



POSITIONS PER ROW	A	B	POSITIONS PER ROW	POLARIZED POSITIONS (No Contact)
-05	(13.40) .528	(11.50) .453	-05	3, 4
-08	(19.40) .764	(17.50) .689	-08	5, 6
-20	(43.40) 1.709	(41.50) 1.634	-20	15, 16
-30	(63.40) 2.496	(61.50) 2.421	-30	21, 22
-40	(83.40) 3.283	(81.50) 3.209	-40	31, 32
-50	(103.40) 4.071	(101.50) 3.996	-50	41, 42

Note:
Some sizes, styles and
options are non-standard,
non-returnable.

View complete specifications at: samtec.com?MEC2-DV & samtec.com?MEC2-TH



PCI EXPRESS® EDGE CARD SOCKETS

(1.00 mm) .0394" PITCH

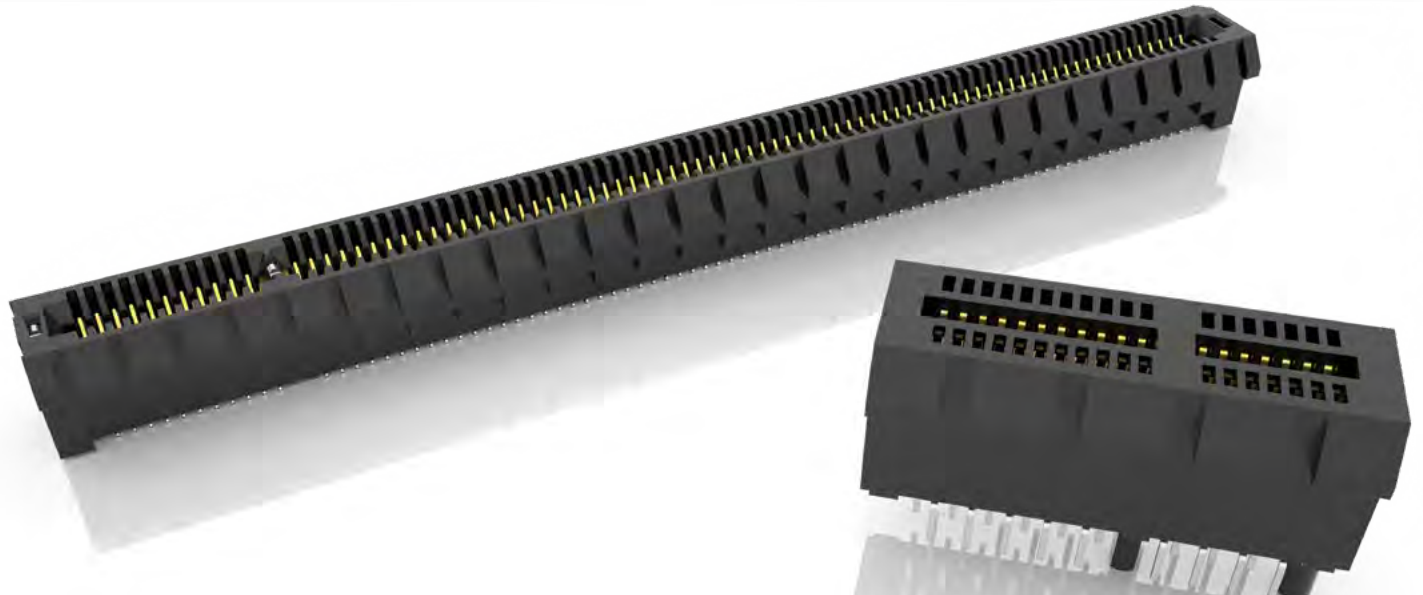

FEATURES & BENEFITS

- 1.00 mm pitch
- Supports 1, 4, 8 and 16 PCI Express® links
- PCIe® 3.0 Solution (PCI-E)
- PCIe® 4.0 Solution with low-profile design for space savings (PCI-E-LP)
- PCIe® 4.0 with slim body design (PCI-E-G4)
- PCIe® 5.0 Solution with differential pair signaling (PCI-E-G5)
- Vertical, right-angle and edge mount
- Mates with .062" (1.60 mm) thick cards
- Alignment pin and weld tab options

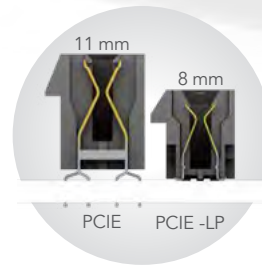

PCI-E® 3.0 & 4.0
Edge Card
connectors



PCI-E® 4.0 slim body
socket with Edge Rate®
contacts (PCI-E-G4)

KEY SPECIFICATIONS

SERIES	TOTAL PINS (LANES)	INSULATOR MATERIAL	CONTACT MATERIAL	OPERATING TEMP RANGE	CURRENT RATING	VOLTAGE RATING	PCI-E® COMPATIBILITY
PCI-E	36 (x1), 64 (x4), 98 (x8), 164 (x16)	-TH = Black Nylon -EMS2 & -TH = LCP	Phosphor Bronze	-55 °C to +125 °C	2.4 A (2 pins)	215 VAC	3.0
PCI-E-LP	36 (x1), 64 (x4), 98 (x8), 164 (x16)	LCP	Phosphor Bronze	-55 °C to +125 °C	2.1 A (2 pins)	215 VAC	4.0
PCI-E-G4	36 (x1), 64 (x4), 98 (x8), 164 (x16)	LCP	Copper Alloy	-55 °C to +125 °C	2.2 A (2 pins)	300 VAC	4.0
PCI-E-G5	36 (x1), 64 (x4), 98 (x8), 164 (x16)	LCP	Copper Alloy	-55 °C to +125 °C	3.2 A (2 pins)	235 VAC	5.0

(1.00 mm) .0394" PITCH • PCI EXPRESS® CARD SOCKETS

PCIE - **NUMBER OF POSITIONS** - **02** - **PLATING OPTION** - **D** - **TAIL OPTION**

**-036, -064,
-098, -164**

-F
= Gold flash on contact,
Tin on tail

-EMS2
= Edge Mount

-TH
= Through-hole

-RA
= Right-angle

PCIE

Card Mates:
(1.60 mm)
.062" card
Cable Mates:
PCIEC



POSITIONS	A
-036 (x1)	(25.00) .984
-064 (x4)	(39.00) 1.535
-098 (x8)	(56.00) 2.205
-164 (x16)	(89.00) 3.504

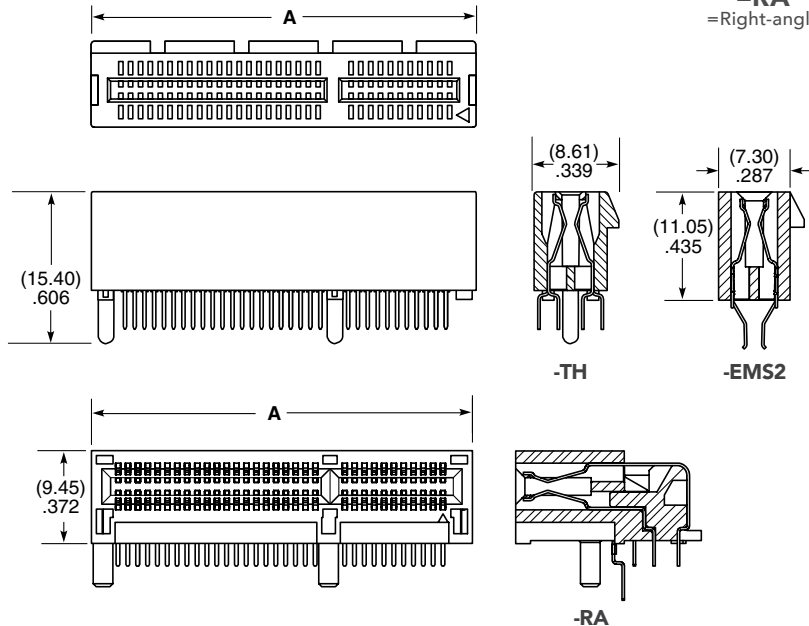

View complete specifications at: samtec.com?PCIE

PCIE - **LP** - **NUMBER OF LANES** - **01** - **PLATING OPTION** - **DV** - **A** - **OPTION** - **PACKAGING**

**-01, -04,
-08, -16**

-F
= Gold Flash on
contact, Matte
Tin on tail

-S
= 30 μ" (0.75 μm)
Gold on contact,
Matte Tin on tail

-WT
= Weld Tab

-K
= Polyimide film
Pick & Place Pad

(For -16 lanes
only leave blank for
Tray Packaging)

-TR
= Tape & Reel
(Available with
-01, -04, -08
lanes only)

-FR
= Full Reel
Tape & Reel
(must order max.
quantity per reel;
contact Samtec for
quantity breaks)
(Available with -01,
-04, -08 lanes only)

PCIE-LP

Card Mates:
(1.60 mm)
.062" card
Cable Mates:
PCIEC

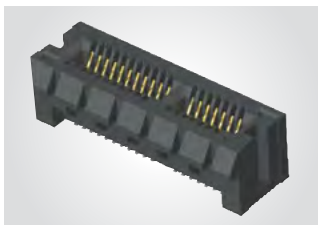

PCI-SIG®, PCI Express® and the PCIe® design marks are registered trademarks and/or service marks of PCI-SIG.

Note:
Some lengths, styles and options are non-standard, non-returnable.

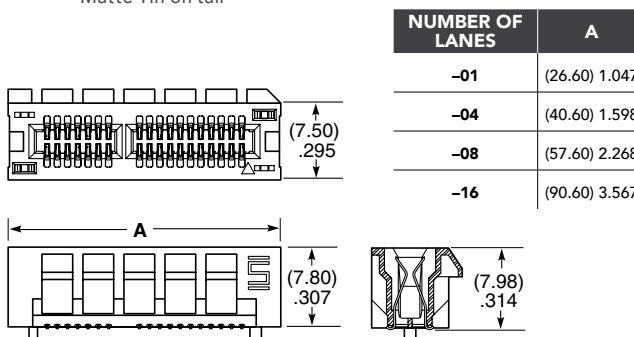

NUMBER OF LANES	A
-01	(26.60) 1.047
-04	(40.60) 1.598
-08	(57.60) 2.268
-16	(90.60) 3.567

View complete specifications at: samtec.com?PCIE-LP

(1.00 mm) .0394" PITCH • PCI EXPRESS® 4.0 SOCKET

PCIE	G4	NUMBER OF LANES	01	PLATING OPTION	DV	OPTION 1	OPTION 2	PACKAGING
		-01, -04, -08, -16		-F = Gold flash on contact, Matte Tin on tail -S = 30 μ" (0.76 μm) Gold on contact, Matte Tin on tail		-A = Alignment Pin (Not available with -WT) -WT = Weld Tab (Not available with -A)	-K = (7.00 mm) .275" DIA Polyimide Pick & Place Pad	(For -16 lanes only leave blank for Tray Packaging) -TR = Tape & Reel (Available with -01, -04, -08 lanes only) -FR = Full Reel Tape & Reel (must order maximum quantity per reel; contact Samtec for quantity breaks) (Available with -01, -04, -08 lanes only)

PCIE-G4
Card Mates:
(1.60 mm)
.062" card

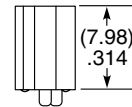
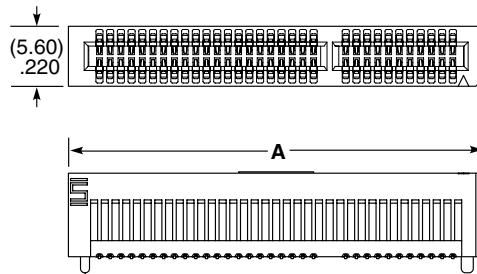

NUMBER OF LANES	A
-01	(26.70) 1.051
-04	(40.70) 1.602
-08	(57.70) 2.272
-16	(90.70) 3.571

View complete specifications at: samtec.com?PCIE-G4

(1.00 mm) .0394" PITCH • PCI EXPRESS® 5.0 SOCKET

PCIE	G5	NUMBER OF LANES	01	PLATING OPTION	DP	A	OPTION
		-01, -04, -08, -16		-F = Gold flash on contact, Matte Tin on tail -S = 30 μ" (0.76 μm) Gold on contact, Matte Tin on tail			-WT = Weld Tab

PCIE-G5
Card Mates:
(1.60 mm)
.062" card

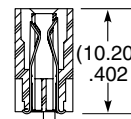
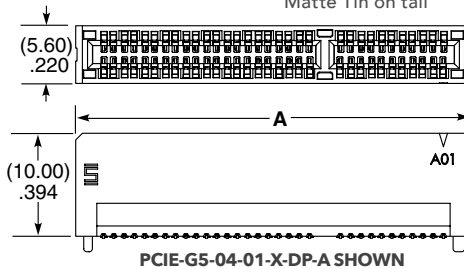

NUMBER OF LANES	A	B (with -WT)
-01	(24.40) .961	(26.70) 1.051
-04	(38.40) 1.512	(40.70) 1.602
-08	(55.40) 2.181	(57.70) 2.272
-16	(88.40) 3.480	(90.70) 3.571

PCIE-G5-04-01-X-DP-A SHOWN

PRELIMINARY

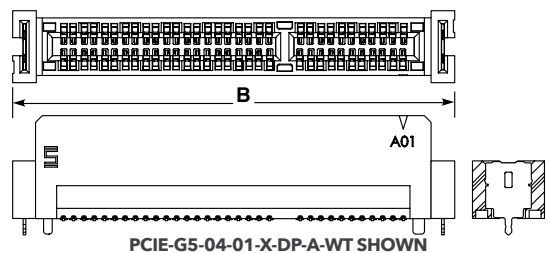

PCIE-G5-04-01-X-DP-A-WT SHOWN

PCI-SIG®, PCI Express® and the PCIe® design marks are registered trademarks and/or service marks of PCI-SIG.

Note:
Some lengths, styles and options are non-standard, non-returnable.

View complete specifications at: samtec.com?PCIE-G5

HIGH-SPEED THROUGH BOARD SOCKET

(1.00 mm) .0394" PITCH • SAL1 SERIES

14
Gbps



SAL1

Card Mates:

(1.60 mm) .062" or
(2.36 mm) .093" card

SPECIFICATIONS

Insulator Material:

Black LCP

Contact Material:

BeCu

Plating:

Au or Sn over 50 μ" (1.27 μm) Ni

Operating Temp Range:

-55 °C to +125 °C

Current Rating:

2.9 A per pin
(2 adjacent pins powered)

PROCESSING

Lead-Free Solderable:

Yes

SMT Lead Coplanarity:

(0.10 mm) .004" max

SAL1	-	1	NO. OF POSITIONS	-	01	PLATING OPTION	-	S	-	A	OPTION
			-20, -27, -30, -40			-S = 30 μ" (0.76 μm) Gold on contact, Matte tin on tail					-TR = Tape & Reel -FR = Full Reel Tape & Reel (must order maximum quantity per reel; contact Samtec for quantity breaks)

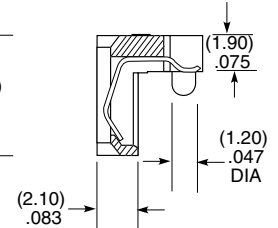
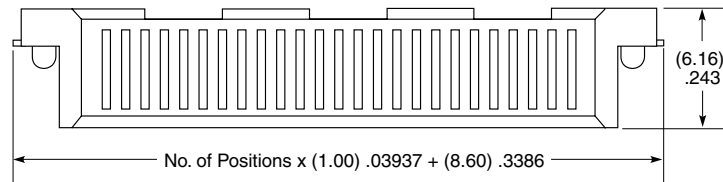
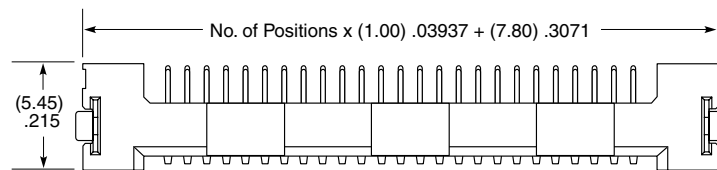

OTHER SOLUTION

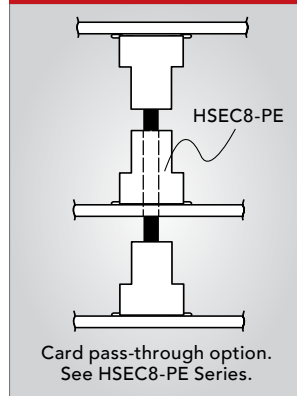

APPLICATIONS

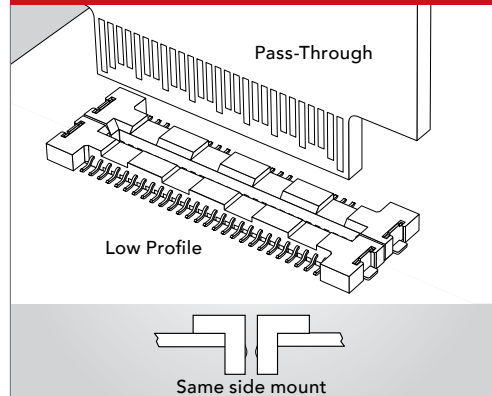

Notes:

While optimized for 50 Ω applications, this connector with alternative signal/ground patterns may also perform well in certain 75 Ω applications..

Some lengths, styles and options are non-standard, non-returnable.

View complete specifications at: samtec.com?SAL1

EDGE CARD REFERENCE GUIDE

	MEC5	HSEC6	MEC6	MEC8	HSEC8	HSEC8-DP	HTEC8
METROLOGY							
Pitch	0.50 mm	0.60 mm	0.635 mm	0.80 mm			
Total Pin Counts	60-300	56, 84, 140, 168	20-140		18-200	16, 24, 32, 40, 64, 112	40-200
Linear Density (circuits/mm)	3.30	2.35, 2.36, 2.46, 2.42	2.67	2.19	2.28		
Card Thickness	.062"		.062"		.062" & .093"	.062"	
Orientations Available	V, RA	V	V, RA	V, RA, EM, PF	V, RA, EM, PT	V	
MECHANICAL PERFORMANCE							
Average Normal Force per Circuit (GRF)	50	96	100		60	38	
Wipe (mm)	1.10	1.20	2.00	2.10	2.00	2.48	1.91
Mating/Unmating Force per Circuit (GRF)	30/25	46	50/30		40/20		TBD
ELECTRICAL PERFORMANCE (LOW FREQUENCY)							
Current Carrying Capacity (Amps)	1.5 (2 pins)	0.8 (12 pins)	2.4 (2 pins)	1.8 (4 pins)	2.8 (2 pins)	2.7 (2 pins)	3.0 (2 pins)
Working Voltage (VAC)	125	300	195	185	240	235	215
PCIe® Compatibility	4.0	5.0	2.0	2.0	4.0	5.0	4.0
ELECTRICAL PERFORMANCE (HIGH FREQUENCY)							
Designed to be Impedance Matched	Yes	Yes	No			Yes	No
Channel Performance Metric (Gbps)	56 PAM4		14	25	28	56 PAM4	28
Characteristic Impedance (Single-Ended, 30 ps rise time, Ohms)	42-55	85	46-58	41-56	43-58	Differential Pair	
ENVIRONMENTAL PERFORMANCE							
Durability (Cycles)	100	25	100	1,000			100
MFG Tested	No		Yes			No	

Au is the only interface finish available. Recommended operating environment is a controlled environment.

	SAL1	MEC1	HSEC1	PCIE-LP	PCIE	MECF	MEC2
METROLOGY							
Pitch	1.00 mm				1.27 mm	2.00 mm	
Total Pin Counts	20, 27, 30, 40	20-140	20-140	36 (x1), 64 (x4), 98 (x8), 164 (x16)		10-100	10-100
Linear Density (circuits/mm)	1.96	1.88	1.76	1.84		1.48	0.97
Card Thickness	Variable	.062"			.062" & .093"		
Orientations Available	PT	V, RA, EM	V		V, RA, EM	V	
MECHANICAL PERFORMANCE							
Average Normal Force per Circuit (GRF)	80	60		75	55	70	
Wipe (mm)	1.50	2.95	2.00	2.70	3.50	3.00	
Mating/Unmating Force per Circuit (GRF)	40/30	40/20		30/15		45/20	
ELECTRICAL PERFORMANCE (LOW FREQUENCY)							
Current Carrying Capacity (Amps)	2.9 (2 pins)	2.2 (2 pins)		2.1 (2 pins)	2.4 (2 pins)	3.5 (2 pins)	
Working Voltage (VAC)	215	250	215	215		280	238
PCIe® Compatibility	2.0	2.0	4.0	4.0	3.0	2.0	2.0
ELECTRICAL PERFORMANCE (HIGH FREQUENCY)							
Designed to be Impedance Matched	No			No			No
Channel Performance Metric (Gbps)	14		28	28	14	25	14
Characteristic Impedance (Single-Ended, 30 ps rise time, Ohms)	43-70	33-57	45-55	Differential Pair		43-70	43-58
ENVIRONMENTAL PERFORMANCE							
Durability (Cycles)	100	500	1,000	100			100
MFG Tested	No		Yes	No	Yes	No	

Au is the only interface finish available. Recommended operating environment is a controlled environment.

All products are tested to a standard amplitude and frequency; this parameter gives an average resistance change as a result of that standardized test.

HIGH-SPEED BACKPLANE SYSTEMS

HIGH-DENSITY • DESIGN FLEXIBILITY • HIGH RELIABILITY

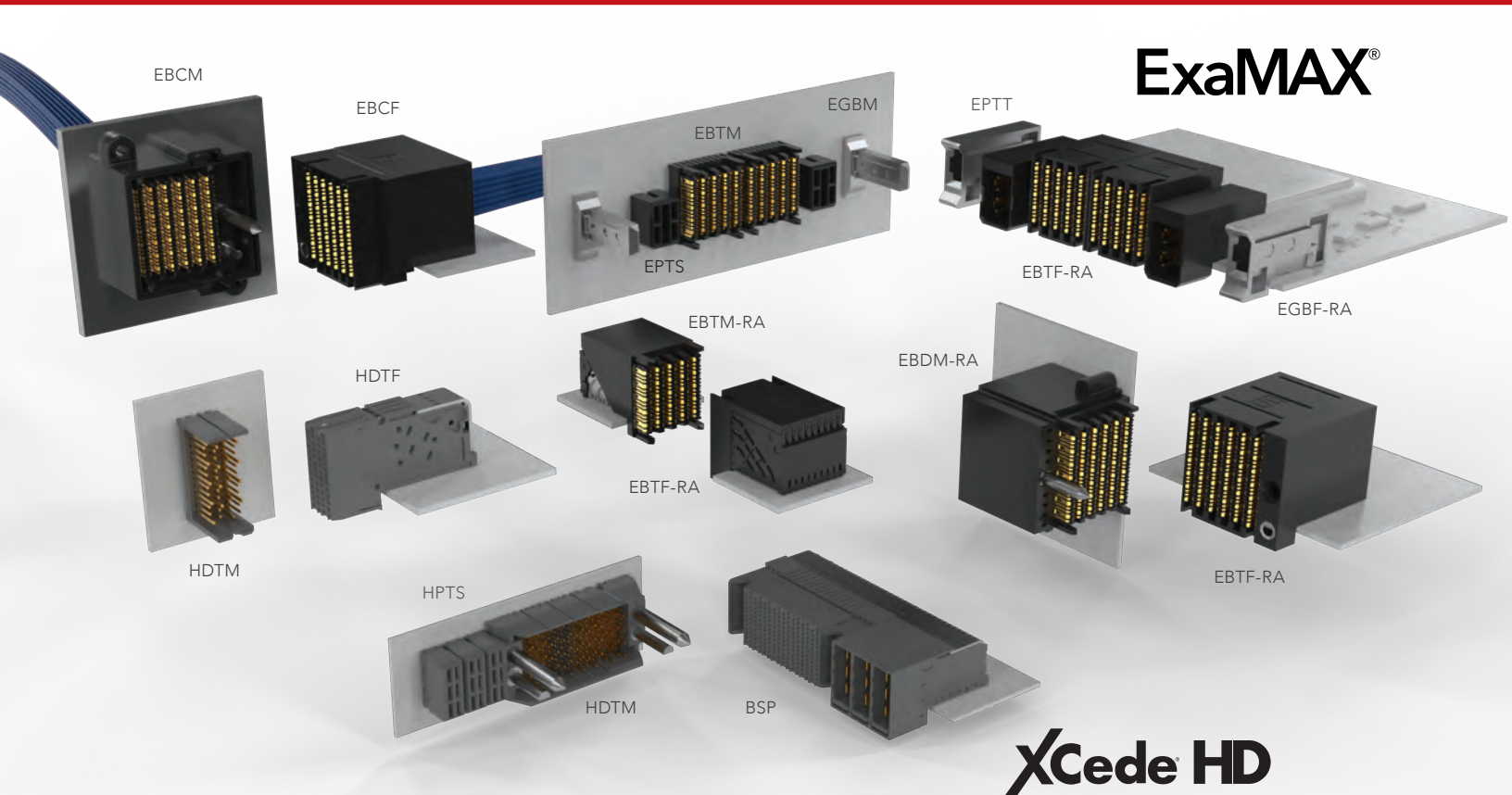

86-91

ExaMAX®

ExaMAX® Vertical & Right-Angle Headers (EBTM)	87
ExaMAX® Right-Angle Receptacles (EBTF-RA)	88
ExaMAX® Direct-Mate Orthogonal Headers (EBDM-RA)	88
Power Modules for ExaMAX® (EPTT, EPTS)	89
Guidance Modules for ExaMAX® (EGBM, EGBF)	89
ExaMAX® Cable Systems (EBCM, EBCF, EBCB, EBCL)	90-91

92-94

XCede® HD

XCede® HD Backplane Headers & Receptacles (HDTM, HDTF)	92-94
XCede® HD Power Modules (HPTS)	94

ExaMAX[®]

HIGH-SPEED BACKPLANE CONNECTOR & CABLE SYSTEMS

(2.00 mm) .0787" PITCH

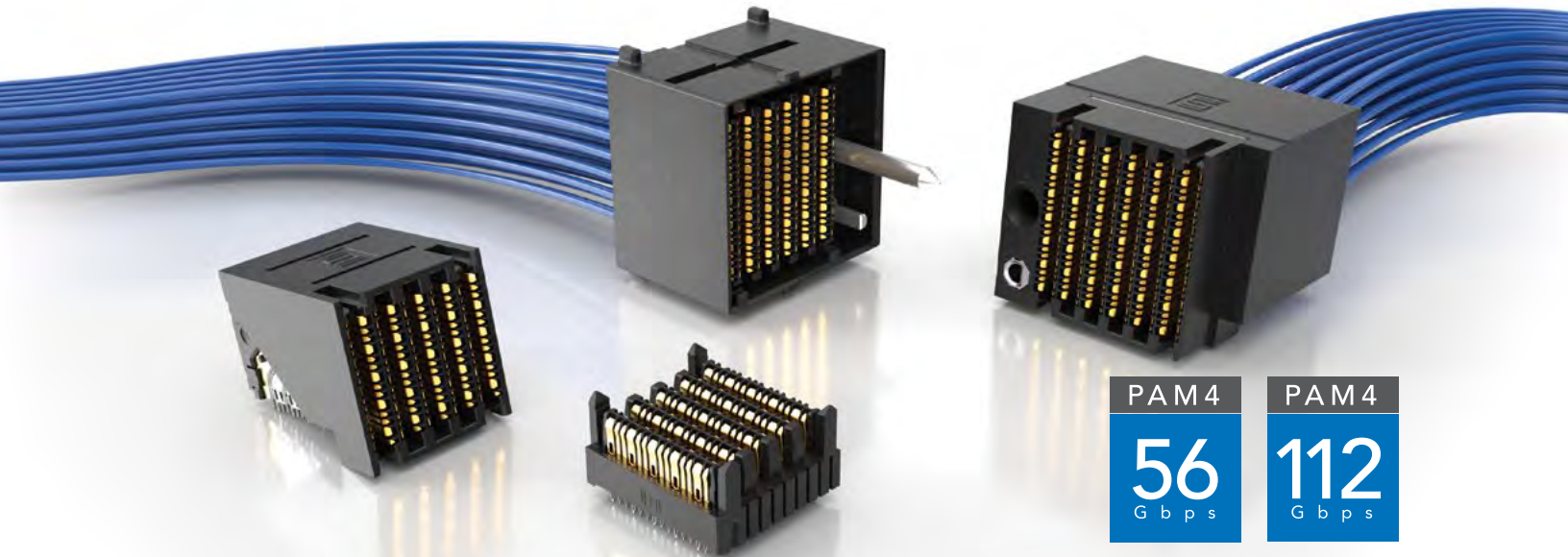

FEATURES & BENEFITS

ExaMAX[®] High-Speed Backplane System

- Meets a variety of industry specifications
- Exceeds OIF CEI-28G-LR specification for 28 Gbps standards
- 24 - 72 pair designs (4 and 6 pairs; 6, 8, 10 and 12 columns)
- Wafer design increases isolation for reduced crosstalk
- Press-fit tails provide a reliable electrical connection

ExaMAX[®] High-Speed Backplane Cable Assemblies

- 30 & 34 AWG Eye Speed[®] Ultra Low Skew Twinax Cable offers improved signal integrity, increased flexibility and routability
- Highly customizable with modular flexibility
- Reduce costs due to lower layer counts
- Multiple end options available



Staggered Differential Pair Design

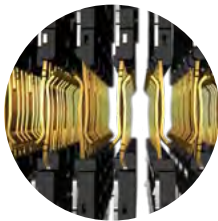

Two Reliable Points of Contact at All Times

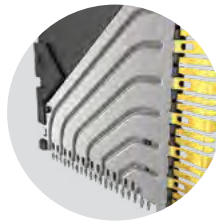

Wafer Design Reduces Crosstalk



Traditional, Coplanar and Direct Mate Orthogonal



Intermateable with all ExaMAX[®] Connectors

KEY SPECIFICATIONS

PITCH	INSULATOR MATERIAL	CONTACT MATERIAL	PLATING	OPERATING TEMP RANGE	CURRENT RATING
2.00 mm	LCP Zinc Alloy (EGBX Series only)	Copper Alloy	Sn over 50 μ " (1.27 μ m) Ni	-55 °C to +105 °C	4.2 A per pin

samtec.com/ExaMAX

Unless otherwise approved in writing by Samtec, all parts and components are designed and built according to Samtec's specifications which are subject to change without notice.

(2.00 mm) .0787" PITCH • VERTICAL & RIGHT-ANGLE HEADERS

EBTM	NO. OF PAIRS PER COLUMN	COLUMNS	COLUMN PITCH	PLATING	ORIENTATION	1	GUIDANCE	KEYING
	-4 = 4 Pairs	-06, -08, -10, -12 (-12 column only available in -6 pairs)	-2.0 = (2.0 mm) .0787"	-S = 30 μm (0.76 μm) Gold on contact area, Matte Tin on tail	-VT = Vertical		(Leave Blank for no Guidance)	(Only available with -L or -R Guidance) (Leave Blank for no Keying)
	-6 = 6 Pairs				-RA = Right-Angle		-L = Left Guidance	
							-R = Right Guidance	-A thru -H = Position of flat on Key (See Table)

EBTM-VT
Board Mates:
EBTF-RA

Cable Mates:
EBCF

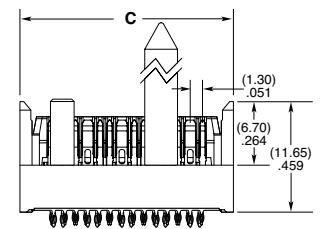
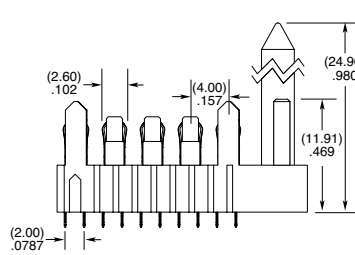
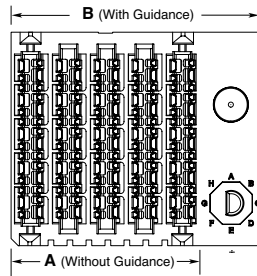
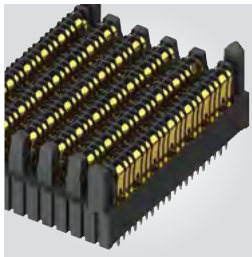

KEYING (-VT)								
-L / -R	-A	-B	-C	-D	-E	-F	-G	-H

COLUMNS	A	B
-06	(11.90) .469	(18.35) .722
-08	(15.90) .626	(22.35) .880
-10	(19.90) .783	(26.35) 1.037
-12	(23.90) .941	(30.35) 1.195

NO. OF PAIRS PER COLUMN	C
-4	(22.50) .886
-6	(29.70) 1.169

View complete specifications at: samtec.com?EBTM

EBTM-RA
Board Mates:
EBTF-RA

Cable Mates:
EBCF

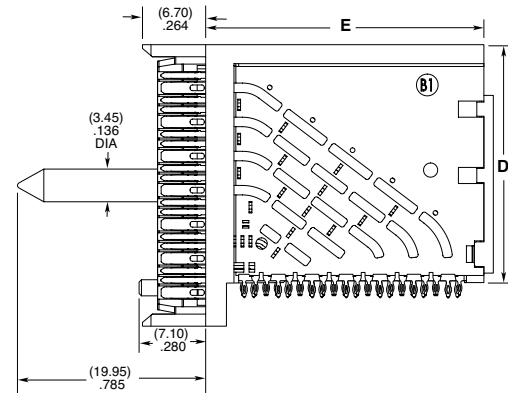
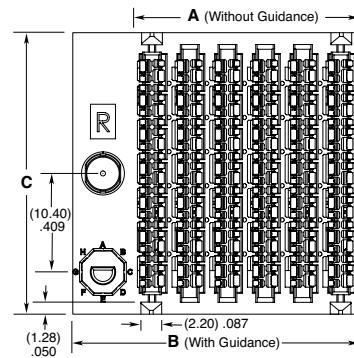

KEYING (-RA)								
-L / -R	-A	-B	-C	-D	-E	-F	-G	-H

COLUMNS	A	B
-06	(11.90) .469	(18.35) .722
-08	(15.90) .626	(22.35) .880
-10	(19.90) .783	(26.35) 1.037
-12	(23.90) .941	(30.35) 1.195

NO. OF PAIRS PER COLUMN	C	D	E
-4	(22.50) .886	(17.90) .705	(23.30) .917
-6	(29.70) 1.169	(25.10) .988	(30.50) 1.201

View complete specifications at: samtec.com?EBTM-RA

Notes:
Some lengths, styles and options are non-standard, non-returnable.
ExaMAX[®] is a registered trademark of AFCL.

(2.00 mm) .0787" PITCH • RIGHT-ANGLE SOCKET & DIRECT-MATE ORTHOGONAL

EBTF	NO. OF PAIRS PER COLUMN	COLUMNS	COLUMN PITCH	PLATING	RA	1	GUIDANCE	KEYING
	-4 = 4 Pairs -6 = 6 Pairs	-06, -08, -10, -12 (-12 column only available in -6 pairs)	-2.0 = (2.0 mm) .0787"	-S = 30 μm (0.76 μm) Gold on contact area, Matte Tin on tails			(Leave Blank for no Guidance) -L = Left Guidance -R = Right Guidance	(Only with -L or -R Guidance; Leave Blank for no Keying) -A thru -H = Position of Flat on Key (See Table)

EBTF-RA
Board Mates:
EBTM,
EBDM-RA

Cable Mates:
EBCM

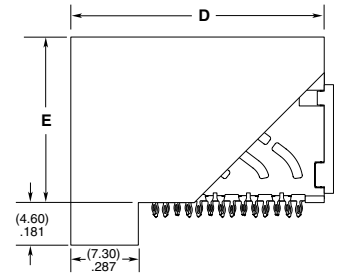
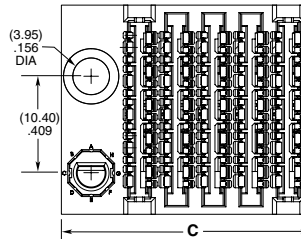
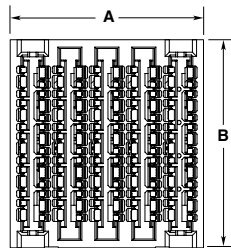

KEYING (-RA)								
-L / -R	-A	-B	-C	-D	-E	-F	-G	-H

NO. OF COLUMNS	A	C
-06	(12.90) .508	(18.85) .742
-08	(16.90) .665	(22.85) .900
-10	(20.90) .823	(26.85) 1.057
-12	(24.90) .980	(30.85) 1.215

NO. OF PAIRS PER COLUMN	B	D	E
-4	(22.50) .886	(28.40) 1.118	(17.90) .705
-6	(29.70) 1.169	(35.60) 1.402	(25.10) .988

View complete specifications at: samtec.com?EBTF-RA

EBDM	PAIRS	COLUMNS	2.0	PLATING	RA	1	GUIDANCE	SCREW MOUNT
------	-------	---------	-----	---------	----	---	----------	-------------

-6
= 6 Pairs

-06, -08,
-10, -12

-S
= 30 μm (0.76 μm) Gold on contact area, Matte Tin on tails

(Leave Blank for no Pin)

(Leave Blank for no Screw Mount)

-G
= Guide Pin

-S
= Screw Mount

EBDM-RA
Board Mates:
EBTF-RA

Cable Mates:
EBCF

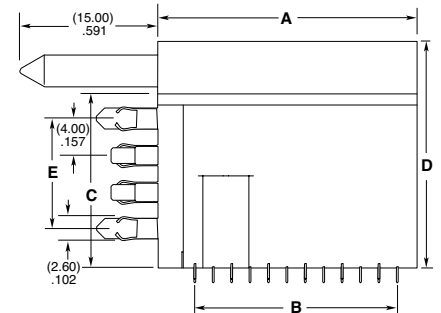
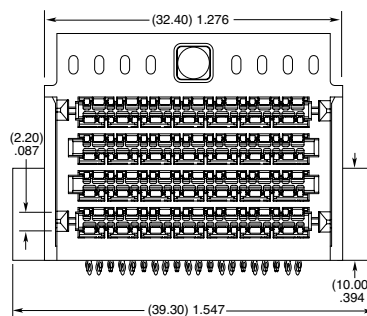
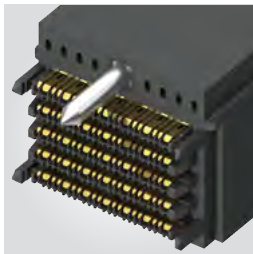

COLUMNS	A	B	C (without -G)	D (with -G)	E
-06	(16.15) .636	(10.00) .394	(15.00) .591	(20.65) .813	(8.00) .315
-08	(20.15) .793	(14.00) .551	(19.00) .748	(24.65) .970	(12.00) .472
-10	(24.15) .951	(18.00) .709	(23.00) .906	(28.65) 1.128	(16.00) .630
-12	(28.15) 1.108	(22.00) .866	(27.00) 1.063	(32.65) 1.285	(20.00) .787

Notes:
Some lengths, styles and options are non-standard, non-returnable.

ExaMAX[®] is a registered trademark of AFCL.

View complete specifications at: samtec.com?EBDM-RA

ExaMAX[®] POWER MODULES

(2.00 mm) .0787" PITCH TERMINAL POWER MODULES



EPTT
Mates with:
EPTS

EPTT	POSITIONS PER ROW	PLATING	HEIGHT	D	ORIENTATION
	-2 = 4 Positions	-P = Palladium with flash Gold on contacts, Matte Tin on tails	-11.5 = (11.50 mm) .453"		-RA = Right-Angle

(2.00 mm) .0787" PITCH SOCKET POWER MODULES



EPTS
Mates with:
EPTT

EPTS	POSITIONS PER ROW	PLATING	D	ORIENTATION	PIN STAGING
	-2 = 4 Positions	-P = Palladium with flash Gold on contacts, Matte Tin on tails		-VT = Vertical -RA = Right-Angle	-01 thru -06 (-RA available with -04 only. Visit website for dimensions.)

View complete specifications at: samtec.com?EPTT & samtec.com?EPTS

ExaMAX[®] GUIDE MODULES

TERMINAL GUIDE MODULES



EGBM
Mates with:
EGBF

EGBM	ORIENTATION	THREADING	LENGTH	CARD SPACING
	-VT = Vertical -RA = Right-Angle	Leave Blank for -RA -1 = External -2 = Internal (25.3 Length only)	Leave Blank for -RA -18.3 = 18.30 mm (.720") -25.3 = 25.30 mm (.996")	-20 = 20 mm (.787")

SOCKET GUIDE MODULES



EGBF
Mates with:
EGBM

EGBF	ORIENTATION	CARD SPACING
	-RA = Right-Angle	-20 = 20 mm (.787")

View complete specifications at: samtec.com?EGBM & samtec.com?EGBF

Notes:
Some lengths, styles and options are non-standard, non-returnable.

ExaMAX[®] is a registered trademark of AFCI.

(2.00 mm) .0787" PITCH • BACKPLANE CABLES

EBCM	GAUGE/ SIG. MAP	PAIRS PER COLUMN	COLUMNS	END 1 PIN	END 1 GUIDE	END 1 KEY	CABLE LENGTH	END 2 PIN	END 2 GUIDE	END 2 KEY
Cable Header	-1 = 34 AWG/Tx to Rx Sig. Map -2 = 30 AWG/Tx to Rx Sig. Map -3 = 34 AWG/1:1 Sig. Map -4 = 30 AWG/1:1 Sig. Map	-4 = 4 Pairs -6 = 6 Pairs	-4, -6, -8, -10, -12, -14, -16	-1 = Standard	-L = Left Guidance -R = Right Guidance	-A thru -H = Position of Flat on Key (See Table) -N = No Key	-"XX" = Length in Inches 06" (152.4 mm) minimum	-1 = Standard	-L = Left Guidance -R = Right Guidance	-A thru -H = Position of Flat on Key (See Table) -N = No Key

NO. OF COLUMNS	A
-4	(17.45) .687
-6	(21.45) .845
-8	(25.45) 1.002
-10	(29.45) 1.159
-12	(33.45) 1.317
-14	(37.45) 1.474
-16	(41.45) 1.632

PAIRS PER COLUMN	B
-4	(24.80) .976
-6	(32.00) 1.260

EBCM
Mates with:
EBCF, EBTf, EBCB

END 1: -L-G SHOWN END 2

View complete specifications at: samtec.com?EBCM

EBCF	GAUGE/ SIG. MAP	PAIRS / COLUMN	COLUMNS	END 1	END 1 PIN	CABLE LENGTH	END 2 OPTION	END 2 PIN	END 2 GUIDE	END 2 KEY
Cable Socket	-1 = 34 AWG/Tx to Rx Sig. Map -2 = 30 AWG/Tx to Rx Sig. Map -3 = 34 AWG/1:1 Sig. Map -4 = 30 AWG/1:1 Sig. Map	-4 = 4 Pairs -6 = 6 Pairs	-4, -6, -8, -10, -12, -14, -16	-V = Vertical Latch	-1 = Standard	-"XX" = Length in Inches 06" (152.4 mm) minimum	-V = Vertical Latch -R = Right- Angle	-1 = Standard	(-R End Only) -L = Left Guidance -R = Right Guidance	(Leave Blank for no Key; -R End Only) -A thru -H = Position of Flat on Key (See Table)

NO. OF COLUMNS	A	C	E
-4	(10.60) .417	(14.85) .585	(19.15) .754
-6	(14.60) .575	(18.85) .742	(23.15) .911
-8	(18.60) .732	(22.85) .900	(27.15) 1.069
-10	(22.60) .890	(26.85) 1.057	(31.15) 1.226
-12	(26.60) 1.047	(30.85) 1.530	(35.15) 1.699
-14	(30.60) 1.205	(34.85) 1.372	(39.15) 1.541
-16	(34.60) 1.362	(38.85) 1.530	(43.15) 1.699

PAIRS PER COLUMN	B	D
-4	(23.00) .906	(22.70) .894
-6	(30.20) 1.189	(29.90) 1.177

KEYING

	-A	-B	-C	-D	-E	-F	-G	-H
-L / -R								

EBCF
Mates with:
EBCM, EBTm, EBCL

END 1: -V SHOWN END 2: -L-G SHOWN

View complete specifications at: samtec.com?EBCF

Notes:
Some lengths, styles and options are non-standard, non-returnable.
ExaMAX[®] is a registered trademark of AFCl.

PANEL RETENTION BRACKETS & LATCHING SHROUDS

EBCB	NO. OF PAIRS	NO. OF COLUMNS	NO. OF BANKS	MOUNTING OPTION
------	--------------	----------------	--------------	-----------------

Panel Retention Bracket

-4
= 4 Pairs

-6
= 6 Pairs

-04, -06, -08, -10, -12, -14, -16
(-04, -06 only available with -1-S)

-1, -2, -4
(-2 & -4 banks available with -08, -10, -12, -14, -16 columns only)

(Leave Blank for Standard)
-S
= Side Lugs (-1 Bank Only)

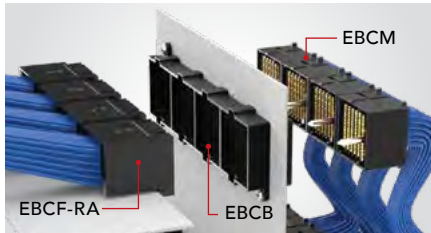

EBCM Cable Assembly Locks into EBCB Retention Bracket

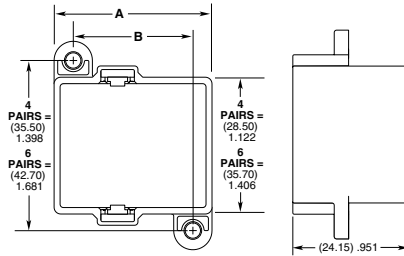

EBCB-X-XX-1 SHOWN

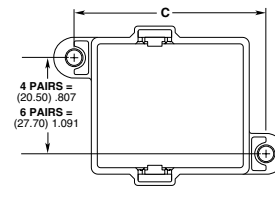

EBCB-X-XX-1-S SHOWN

NO. OF COLUMNS	C
-04	(27.95) 1.100
-06	(31.95) 1.258
-08	(35.95) 1.415
-10	(39.95) 1.573
-12	(43.95) 1.730
-14	(47.95) 1.888
-16	(51.95) 2.045

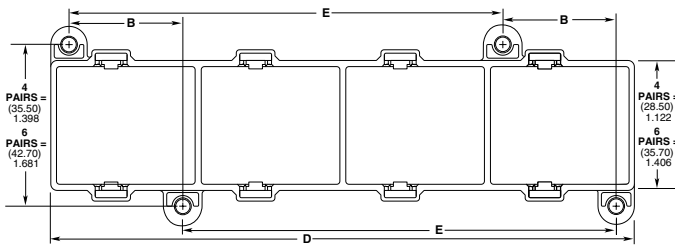

EBCB-X-XX-4 SHOWN

NO. OF COLUMNS	A		B		D 4 Bank	E 4 Bank
	1 Bank	2 Bank	1 or 4 Bank	2 Bank		
-04	(20.95) .825	N/A	N/A	N/A	N/A	N/A
-06	(24.95) .982	N/A	N/A	N/A	N/A	N/A
-08	(28.95) 1.140	(56.65) 2.230	(20.95) .825	(48.65) 1.915	(112.05) 4.411	(83.10) 3.272
-10	(32.95) 1.297	(64.65) 2.545	(24.95) .982	(56.65) 2.230	(128.05) 5.041	(95.10) 3.744
-12	(36.95) 1.455	(72.65) 2.860	(28.95) 1.140	(64.65) 2.545	(144.05) 5.671	(107.10) 4.217
-14	(40.95) 1.612	(80.65) 3.175	(32.95) 1.297	(72.65) 2.860	(160.05) 6.301	(119.10) 4.689
-16	(44.95) 1.770	(88.65) 3.490	(36.95) 1.455	(80.65) 3.175	(176.05) 6.931	(131.10) .5161

View complete specifications at: samtec.com?EBCB

EBCL	NO. OF PAIRS	NO. OF COLUMNS
------	--------------	----------------

Vertical Latching Shroud

-4, -6

-06, -08, -10, -12
(-12 column only available in -6 pairs)

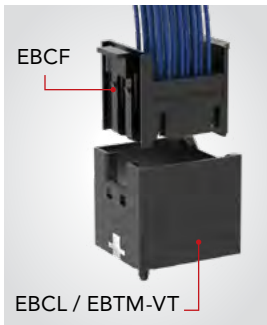

NO. OF COLUMNS	A	B
-06	(22.40) .882	(18.66) .734
-08	(26.40) 1.039	(22.66) .892
-10	(30.40) 1.197	(26.66) 1.050
-12	(34.40) 1.354	(30.66) 1.207

NO. OF PAIRS	C	D	E
-4	(26.20) 1.031	(11.45) .451	(21.50) .846
-6	(33.40) 1.315	(15.05) .593	(28.70) 1.130

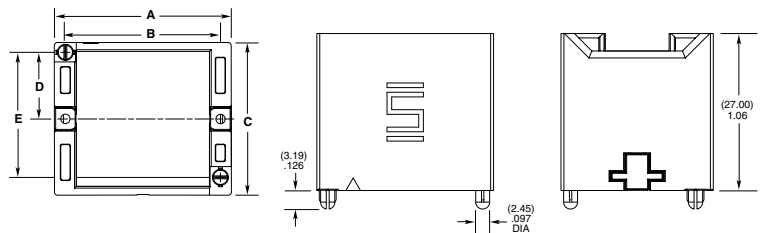

Notes:
Some lengths, styles and options are non-standard, non-returnable.

View complete specifications at: samtec.com?EBCL

ExaMAX® is a registered trademark of AFCI.

XCede[®] HD

HIGH-DENSITY BACKPLANE HEADERS & SOCKETS

(1.80 mm) .071" PITCH

16
Gbps

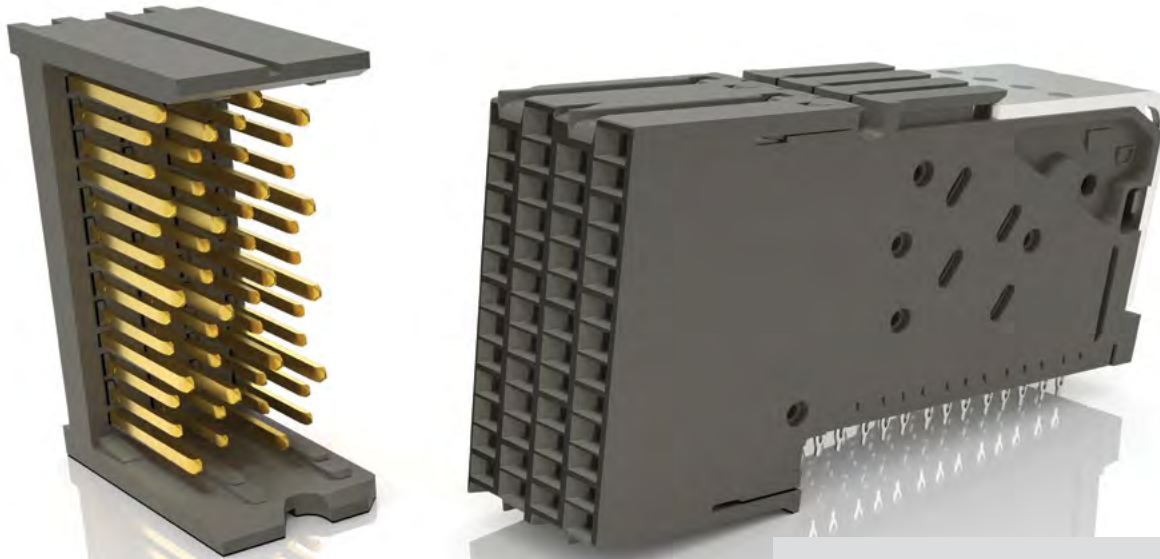

FEATURES & BENEFITS

- Small form factor and modular design provides significant space-savings and flexibility
- High-performance system
- Up to 84 differential pairs per linear inch
- 3, 4 and 6-pair designs on 4, 6 and 8 columns
- Integrated power, guidance, keying and end walls available
- 85 Ω and 100 Ω options
- Combine any configuration of modules to create one integrated receptacle (BSP Series); corresponding terminal modules are individually mounted to the backplane
- Press-fit extraction and insertion tool options; please visit samtec.com/tooling for details

MODULAR DESIGN

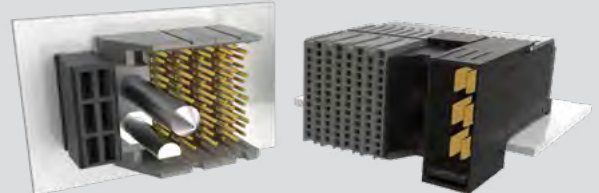

Signal, Power & Keying / Guidance options can be customized in any configuration

HIGH-DENSITY, SMALL FORM FACTOR



XCede[®] HD
Up to 84 pairs per linear inch



Traditional Backplane
Up to 76 pairs per linear inch

(Both shown with six 4-pair, 8 column receptacles)

KEY SPECIFICATIONS

PITCH	INSULATOR MATERIAL	CONTACT MATERIAL	PLATING	OPERATING TEMP RANGE
1.80 mm	LCP	Phosphor Bronze (HDTM Series) Copper Alloy (HDTF & HPTS Series)	Au or Sn over 50 μ" (1.27 μm) Ni	-40 °C to + 105 °C (HDTX Series)

samtec.com/XCedeHD

Unless otherwise approved in writing by Samtec, all parts and components are designed and built according to Samtec's specifications which are subject to change without notice.

(1.80 mm) .071" PITCH • HIGH-DENSITY BACKPLANE HEADER

HDTM	PAIRS	NO. OF COLUMNS	TAIL SIZE	S	VT	SIDE WALLS	GUIDANCE	STAGE COMBO	KEYING
	-3, -4, -6 = Pairs Per Column	-04, -06, -08	-1 = (.4495 mm) .0177" Drill -2 = (.5511 mm) .0217" Drill			-0 = Open (No Walls) -1 = Left -2 = Right -4 = Left Polarizing (-4 Pairs N/A) -5 = Right Polarizing (-4 Pairs N/A)	-4 or -5 Polarizing Only; Leave Blank for No Guidance -L = Left Side Guide Pin -R = Right Side Guide Pin	-1 = 3 mm Wipe Signal / 4 mm Wipe Ground -2 = 2 mm Wipe Signal / 4 mm Wipe Ground -3 = 3 mm Wipe Signal / 3 mm Wipe Ground -4 = 2 mm Wipe Signal / 3 mm Wipe Ground -5 = 2 mm Wipe Signal / 2 mm Wipe Ground	-4 or -5 Polarizing Only; Leave Blank for No Keying -A thru -H = Position of Flat on Key (See Table)

HDTM Board Mates:
HDTF, BSP
(See HDTF for more information.)

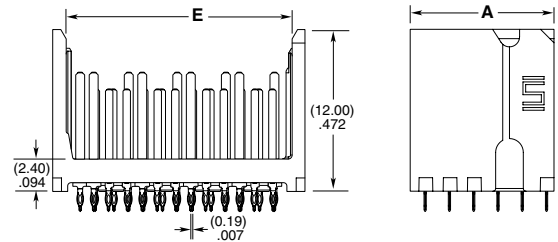
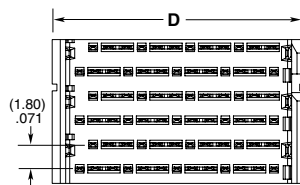
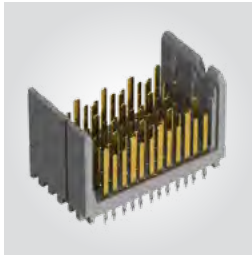

HDTM-4-06-1-S-VT-0-1 SHOWN

NO. OF COLUMNS	A			C	
	No Walls	Left Wall	Right Wall	Left Polarize	Right Polarize
-04	(7.06) .278	(8.20) .322	(8.06) .317	N/A	N/A
-06	(10.66) .420	(11.80) .465	(11.66) .459	(17.14) .675	(16.65) .656
-08	(14.26) .561	(15.40) .606	(15.26) .600	(20.74) .817	(20.25) .797

PAIRS PER COLUMN	D	E
	Standard Wall	
-03	(15.10) .594	(13.15) .518
-04	(18.70) .736	(16.75) .659
-06	(25.90) 1.020	(23.95) .943

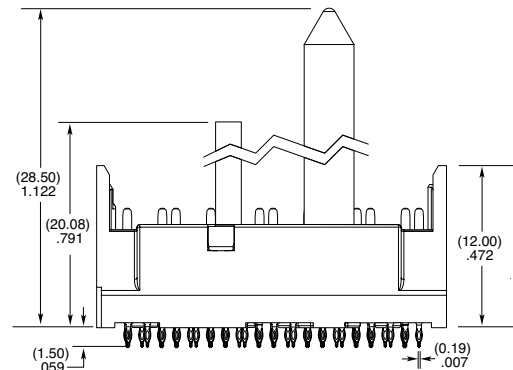
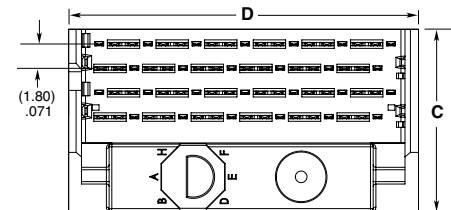

HDTM-6-04-X-X-VT-4-L-X-A SHOWN

KEYING								
-L / -R	-A	-B	-C	-D	-E	-F	-G	-H

View complete specifications at: samtec.com?HDTM

Notes:
Some lengths, styles and options are non-standard, non-returnable.
XCede® is a registered trademark of Amphenol.

(1.80 mm) .071" PITCH • HIGH-DENSITY BACKPLANE RECEPTACLE

HDTF	PAIRS PER COLUMN	NO. OF COLUMNS	PLATING	RA	WAFERS	IMPEDANCE
	-3, -4, -6	-04, -06, -08	-S = 30 μ" (0.76 μm) Gold on Contact Area, Matte Tin on Tail		-LC = Standard -HS = High-Speed	-100 = 100 Ω -085 = 85 Ω

HDTF
Board Mates:
HDTM

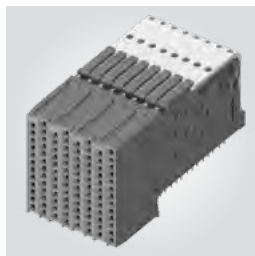

NO. OF COLUMNS	A
-04	(7.2) .28
-06	(10.8) .42
-08	(14.4) .57

PAIRS PER COLUMN	B	C	D
-3	(12.8) .50	(26.0) 1.02	(9.8) .386
-4	(16.4) .64	(29.4) 1.16	(13.5) .53
-6	(23.6) .93	(36.6) 1.44	(20.7) .81

ALSO AVAILABLE

Power and keying/
guidance modules
also are available
but require a single
customizable BSP
product. Contact
HSBP@samtec.com.

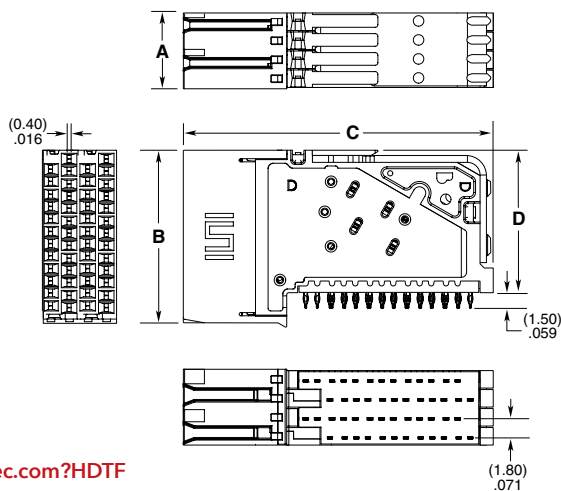

View complete specifications at: samtec.com?HDTF

(3.20 mm) .126" PITCH • HIGH-DENSITY BACKPLANE POWER MODULE

HPTS	BODY HEIGHT	PLATING	D	ORIENTATION
------	-------------	---------	---	-------------

Based on Pair Count of Signal Modules (HDTF Series).

- 3 = For use with 3 pair HDTF Series
- 4 = For use with 4 pair HDTF Series
- 6 = For use with 6 pair HDTF Series

-S
= 30 μ" (0.76 μm) Gold on Contact Area,
Matte Tin on Tail

-VT
= Vertical

HPTS
Mates with:
BSP
(See HDTF
for more
information.)

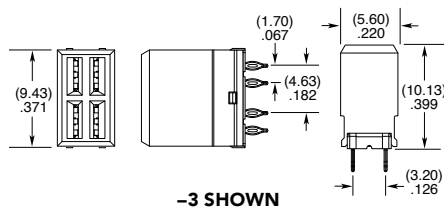

-3 SHOWN

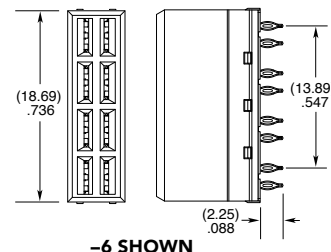

-6 SHOWN

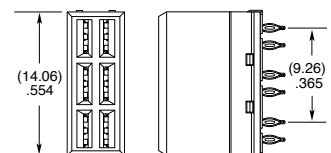

-4 SHOWN

View complete specifications at: samtec.com?HPTS

Notes:
Some lengths, styles and options are non-standard, non-returnable.
XCede[®] is a registered trademark of Amphenol.

HIGH-SPEED CABLE & I/O SYSTEMS

UP TO 112 Gbps PAM4 • FLYOVER® TECHNOLOGY • ULTRA LOW SKEW TWINAX • MICRO COAX CABLE

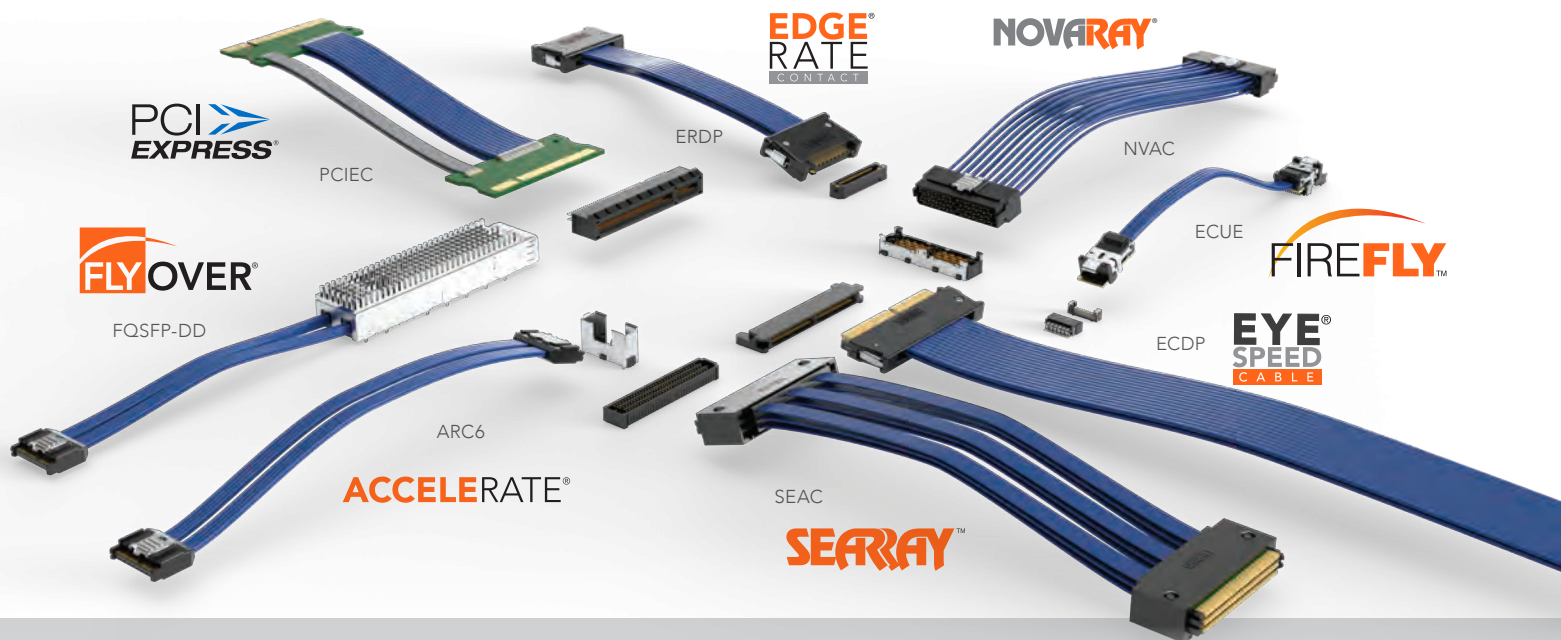

98-110

FLYOVER® SYSTEMS

Flyover® QSFP Cable Systems (FQSFP, FQSFP-DD)	98-101
NovaRay® Extreme Density & Performance Systems (NVAC, NVAM-C)	102-103
AcceleRate® Slim Cable Systems (ARC6, ARF6)	104-105
Si-Fly™ Low-Profile, High-Density Cable System (CPC, CPI)	106-107
Copper FireFly™ Cable Systems (ECUE, PCUE, UEC5, UCC8)	108-110

111-121

COAX & TWINAX

Edge Card Cables (FEDP, FCDP, ECDP)	111-112
Twinax Cable Systems (HQDP, EQDP, ERDP)	113-114
Razor Beam™ Hermaphroditic Coax Cable System (HLCD)	115
Coax Cables (HQCD, EQCD, ERCD)	116-117
SEARAY™ & SEARAY™ 0.80 mm Cables (SEAC, ESCA)	118-119
PCI Express® System (PCIIEC)	120
Cost-Effective Cable System (FCF8, FCS8)	121

122-126

HIGH-SPEED I/O

Eye Speed® Cable Systems (HDLSP, HDI6, EPLSP, ERI8-RA)	122-123
SFP+ Passive Jumpers (SFPE, MECT)	124
USB 2.0 (USB, USBR)	125-126



FLYOVER® TECHNOLOGY

Samtec Flyover® technology breaks the constraints of traditional signaling substrate and hardware offerings by routing signals via ultra low skew twinax cable versus through lossy PCB. This results in a cost-effective, high-performance and heat efficient answer to the challenges of 56 Gbps bandwidths and beyond.

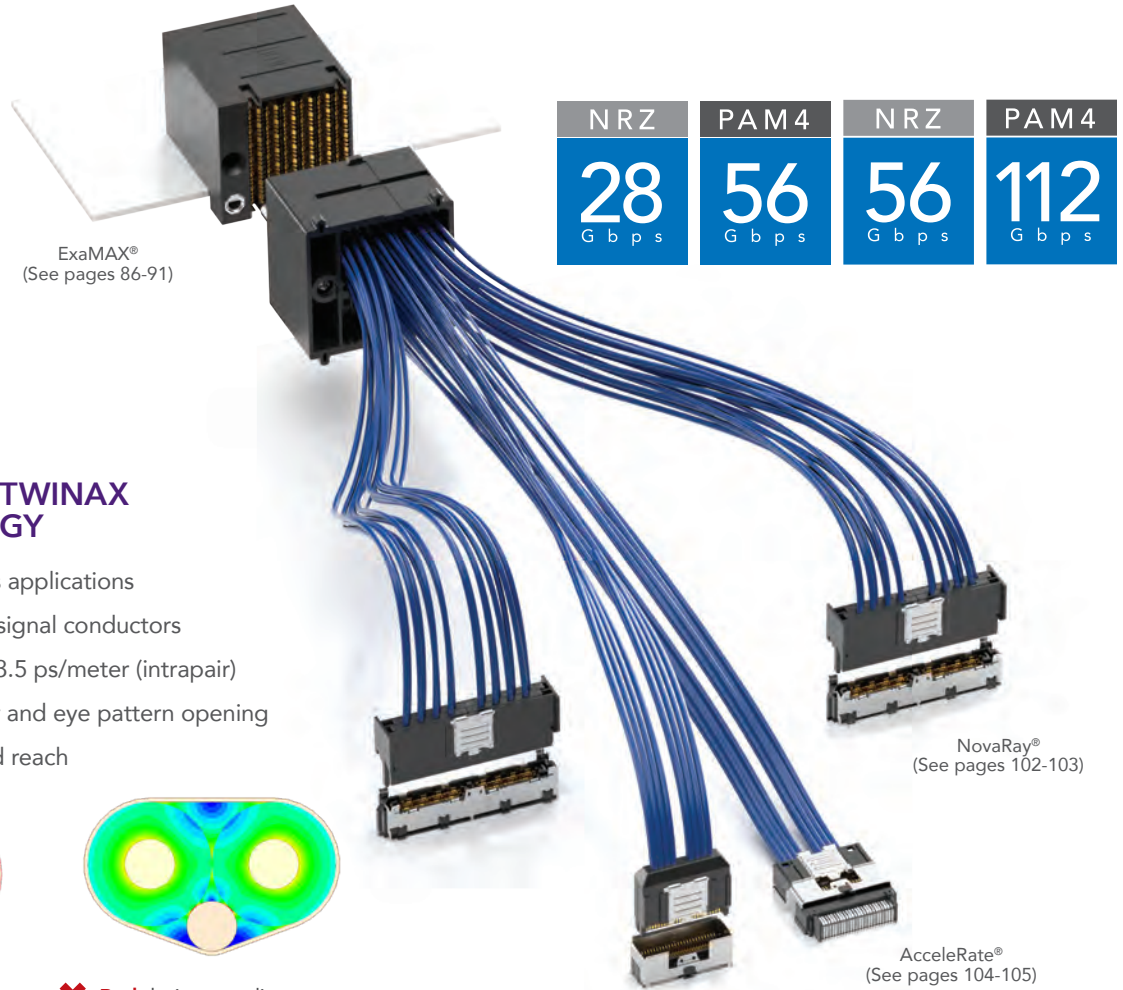

ULTRA LOW SKEW TWINAX CABLE TECHNOLOGY

- Ideal for 28 – 112+ Gbps applications
- Tight coupling between signal conductors
- Ultra low skew twinax < 3.5 ps/meter (intrapair)
- Improved signal integrity and eye pattern opening
- Increased bandwidth and reach

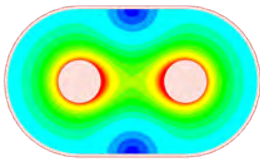

✓ **Good** design coupling with Samtec's co-extruded ultra low skew twinax

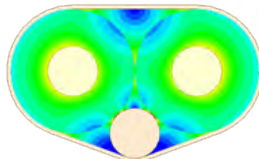

✗ **Bad** design coupling with individually extruded conductors & drain wire

PERFORMANCE & COST ADVANTAGES

- 28 - 56 Gbps NRZ and beyond
- Simplified board layout
- Less expensive PCB materials, fewer PCB layers
- Eliminates expensive re-timers

SUPPORT

Fully integrated Technology Centers for full system optimization from Silicon-to-Silicon, including Samtec's High-Speed Cable Group.

THERMAL IMPROVEMENT

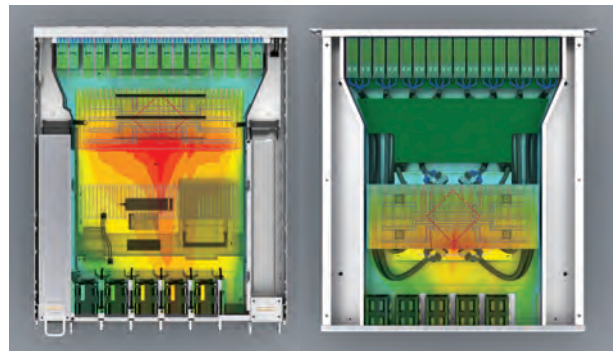

Standard Network Switch vs. Samtec Flyover® Technology

CABLE SPECIFICATIONS



ULTRA LOW SKEW TWINAX CABLE

Samtec's proprietary co-extruded Eye Speed® twinax cable technology eliminates the performance limitations and inconsistencies of individually extruded dielectric twinax cabling; improving signal integrity, bandwidth and reach for high-performance system architectures.

- Micro cellular dielectric extrusion
- Critical dimensions measured at every dielectric spool
- Inline laser and CAPAC devices for capacitance monitoring and diameter control
- In-process stats summary sheet for Cpk acceptance

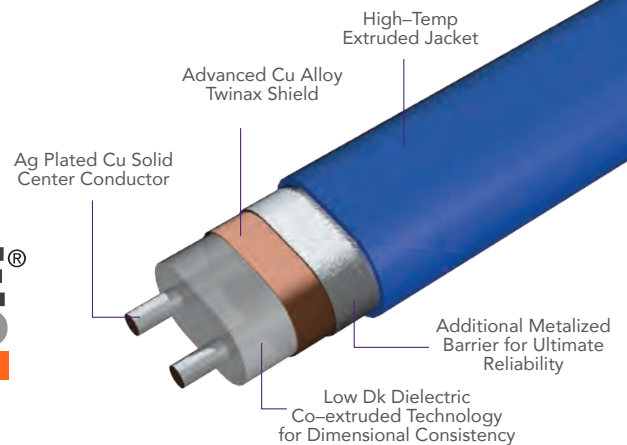

NOMINAL PERFORMANCE SPECIFICATIONS			28 AWG	30 AWG	32 AWG	34 AWG	36 AWG
14 GHz (28G NRZ/56G PAM4)	0.25 m	IL (dB)	-1.0	-1.2	-1.5	-1.8	-2.2
	1.00 m		-4.1	-4.7	-5.9	-7.5	-8.9
28 GHz (56G NRZ/112G PAM4)	0.25 m		-1.5	-1.8	-2.2	-2.7	-3.2
	1.00 m		-6.1	-7.1	-8.7	-10.9	-13.0
Density / Flexibility			Good	Good	Better	Best	Best

Eye Speed® Ultra Low Skew Twinax Cable is available in engineered impedance configurations of 85 Ω, 92 Ω and 100 Ω.

MICRO COAX CABLE

- Foaming introduces air voids for signal to travel faster
- Solid extrusion of foamed dielectric provides a constant and more durable construction
- Lighter weight and smaller size with higher bandwidth capabilities at longer lengths
- 26 - 38 AWG cable available
- Choice of signal conductor, shield and FEP dielectric to meet performance and cost specifications

Individual Serve, Taped or Braided Shield for Excellent Signal Integrity

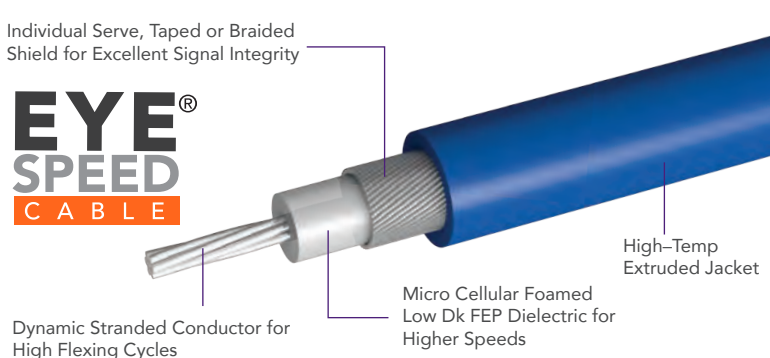

NOMINAL PERFORMANCE SPECIFICATIONS			30 AWG	32 AWG	34 AWG	36 AWG	38 AWG
5 GHz (10 Gbps)	0.25 m	IL (dB)	-0.9	-1.0	-1.3	-2.2	-2.6
	1.00 m		-3.4	-3.3	-6.0	-6.9	-8.5
10 GHz (20 Gbps)	0.25 m		-1.4	-1.6	-2.2	-3.5	-4.0
	1.00 m		-5.1	-5.5	-9.0	-10.7	-12.7
Density / Flexibility			Good	Better	Better	Best	Best

Eye Speed® Micro Coax Cable is available in engineered impedance configurations of 50 Ω and 75 Ω.

FLYOVER® QSFP CABLE ASSEMBLIES

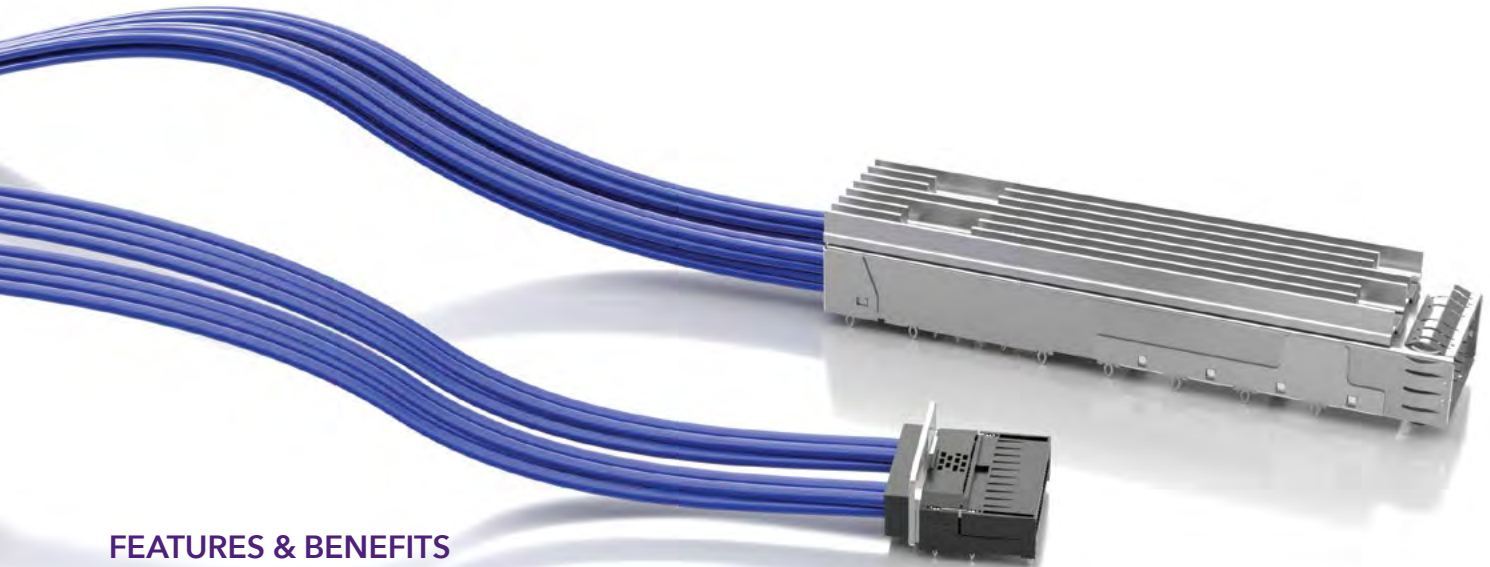

FEATURES & BENEFITS

QSFP28 and QSFP-DD systems utilize Samtec Flyover® technology to route data above lossy PCB, simplifying board layout and extending signal reach. The modular design enables optimized systems that improve heat management, increase signal integrity performance, build in scalability for future upgrades and reduces costs by creating a multifunction board.

NRZ	PAM4
56 Gbps	112 Gbps

FLYOVER® QSFP28 SYSTEM

- 4 Channels (x4 bidirectional, 8 differential pairs)
- ~100 Gbps 28G NRZ aggregate
(~200 Gbps 56G PAM4; 400 Gbps 112G PAM4)
- Compatible with all MSA QSFP pluggables
- Heat dissipation: ~3.5 W/cable
- Eye Speed® 30 or 34 AWG twinax cable
- Multiple end 2 options for design flexibility
- Evaluation Kits available (REF-205303-X.XX-XX and REF-200471-X.XX-XX), visit samtec.com/kits

FLYOVER® QSFP DOUBLE DENSITY

- 8 Channels (x8 bidirectional, 16 differential pairs)
- ~200 Gbps 28G NRZ aggregate
(~400 Gbps 56G PAM4; 800 Gbps 112G PAM4)
- Belly-to-belly mating for maximum density
- Backward compatible with QSFP modules
- Heat dissipation: ~7+ W/cable
- Variety of end 2 options
- Evaluation Kits available (REF-205605-X.XX-XX and REF-203423-X.XX-XX), visit samtec.com/kits



Localized press-fit control and power contacts eliminate the need for a secondary cable and connector



High-speed contacts directly soldered to Eye Speed® ultra low skew twinax



Increases panel density and optimizes airflow

Roadmap: Flyover® QSFP-DD 800G

Samtec is developing Flyover® solutions for 800G including:

- Single to multiple ganged ports
- Belly-to-belly and mezzanine stack configurations
- Contact HDR@samtec.com for more information.

FLYOVER® QSFP28 CABLE ASSEMBLY

FQSFP	LEAD STYLE	CABLE LENGTH	PLATING	CONTACT TYPE	END OPTION
-------	------------	--------------	---------	--------------	------------

-01
= 10 Low-Speed,
8 Pairs High-Speed

-"XX.X"
= Length in inches
04.0" (101.6 mm)
minimum

-L
= 10 μ" (0.25 μm)
Gold over
50 μ" (1.27 μm)
Ni on contact area,
Matte Tin on tail

-PF
= Press-fit

-3
= ECUE
-4
= ARC6-8

FQSFP

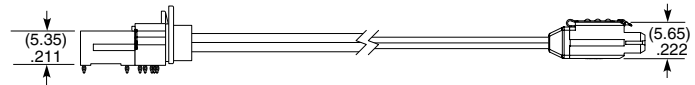
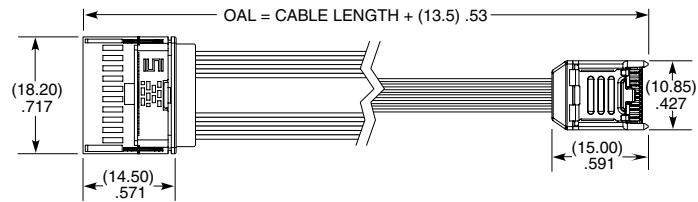

FQSFP-01-XX.X-L-PF-4 SHOWN

QSFP	CAGE OPTION	NO. OF PORTS	EMI PANEL OPTION	OPTION	FLYOVER
------	-------------	--------------	------------------	--------	---------

-1
= Single Stack

-1
= One Port

-S
= Spring
Fingers

(Leave blank for no Light Pipe)

(Leave blank for no flyover)

-2
= Two Ports

-LP
= Light Pipe
(1 & 4 ports only)

-F
= Flyover

-4
= Four Ports

-N
= No heat sink closed top
(Not available with -LP)

QSFP

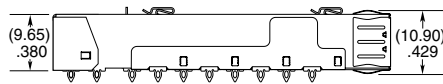
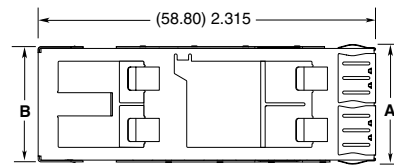
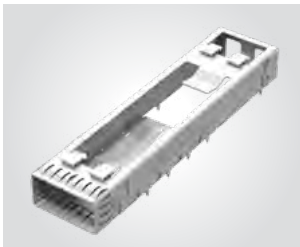

QSFP-1-1-S-F SHOWN

NO. OF PORTS	A	B	C
-1	(20.62) .812	(19.85) .781	(19.00) .748
-2	(39.62) 1.560	(38.85) 1.530	(38.00) 1.496
-4	(77.62) 3.056	(76.85) 3.026	(76.00) 2.992

HEAT SINKS		LIGHT PIPES	
PART NUMBER	HEAT SINK HEIGHT	PART NUMBER	NO. OF PORTS
HS-QSFP-P1-01	(4.20 mm) .165"	LP-FQSFP-1	1 pipe
HS-QSFP-P1-02	(6.50 mm) .256"	LP-FQSFP-2	2 pipes
HS-QSFP-P1-03	(13.50 mm) .531"	LP-FQSFP-4	4 pipes
HS-QSFP-P1-04	(1.50 mm) .059"		

View complete specifications at samtec.com?LP-FQSFP

For Light Pipe, add -LP to the end of part number.
View complete specifications at samtec.com?HS-QSFP

View complete specifications at: samtec.com?FQSFP & samtec.com?QSFP

Notes:
Some sizes, styles and options are non-standard, non-returnable.

FLYOVER® QSFP DOUBLE DENSITY

FQSFP	DD	LEAD STYLE	FOOTPRINT	CABLE LENGTH	END 2 OPTION
		-01 = 20 Low-Speed, 16 Pairs High-Speed	-A = Primary -B = Secondary (Belly-to-Belly only)	-"XX.X" = Length in inches 04.0" (101.6 mm) minimum	-3 = ARC6-16 Additional end options such as NovaRay® available; contact HDR@samtec.com

FQSFP-DD

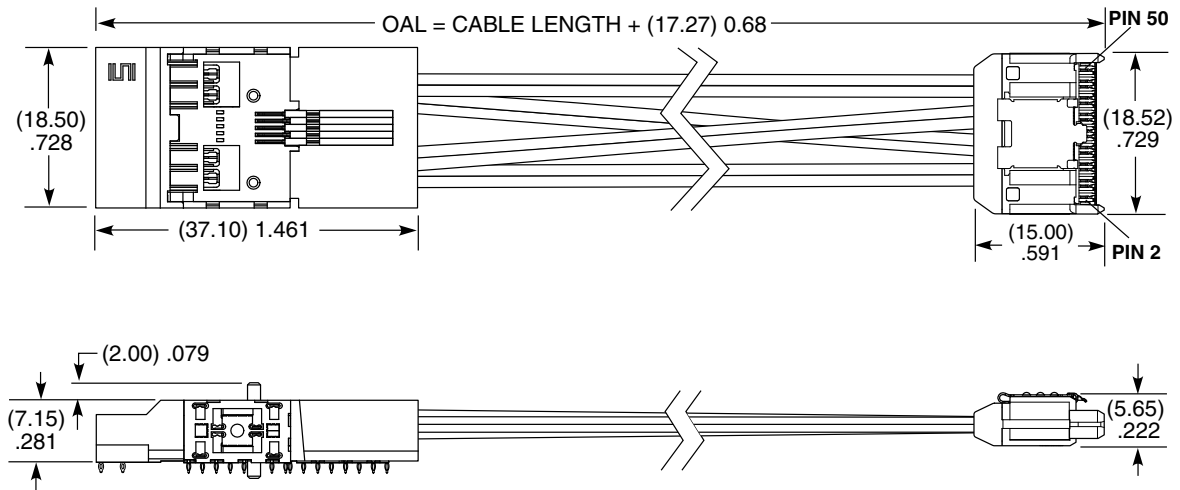

FQSFP-DD-01-X-XX.X-3 SHOWN

TOOLING

Press-fit: CAT-PT-FQSFP-DD-01

Note:
Some sizes, styles and options are non-standard, non-returnable.

View complete specifications at: samtec.com?FQSFP-DD

CAGE & HEAT SINK FOR QSFP-DD

QSFP	DD	STACK	NO. OF PORTS	EMI PANEL OPTION	FLYOVER
		-1 =Single Stack	-1 = One Port -3 = Three Ports	-S = Spring Fingers	-F = Flyover

QSFP-DD

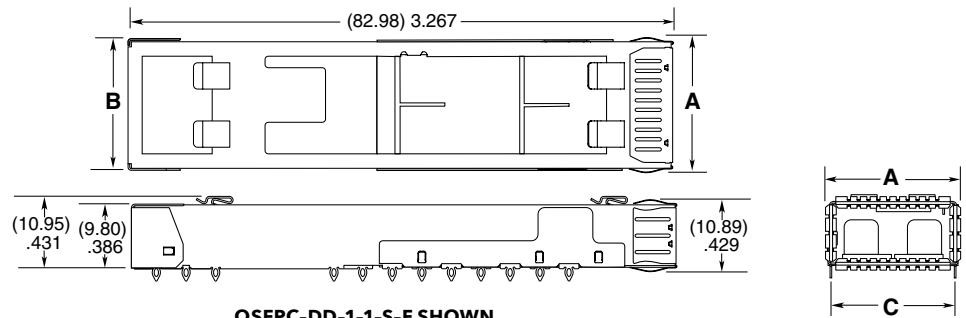
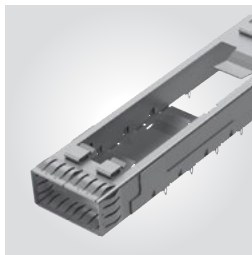

QSFP-DD-1-1-S-F SHOWN

TOOLING

Press-fit: CAT-PT-QSFP-DD-02

NO OF PORTS	A	B	C
-1	(20.62) .812	(19.87) .782	(19.00) .748
-3	(58.62) 2.308	(57.87) 2.278	(57.00) 2.244

View complete specifications at: samtec.com?QSFP-DD

HS-QSFP	DD	HEAT SINK STYLE	HEAT SINK HEIGHT
----------------	-----------	------------------------	-------------------------

-P1
= Pin (Aluminum)

-1
= (4.20 mm) .165" height

-2
= (6.50 mm) .256" height

-3
= (13.50 mm) .531" height

HS-QSFP-DD

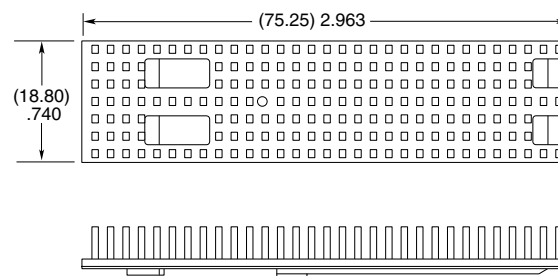

HS-QSFP-DD-P1-2 SHOWN

HEAT SINK HEIGHT	A
-1	(4.20) .165
-2	(6.50) .256
-3	(13.50) .531

Note:
Some sizes, styles and options are non-standard, non-returnable.

View complete specifications at: samtec.com?HS-QSFP-DD

NOVARAY[®]

EXTREME HIGH-SPEED, HIGH-DENSITY CABLE

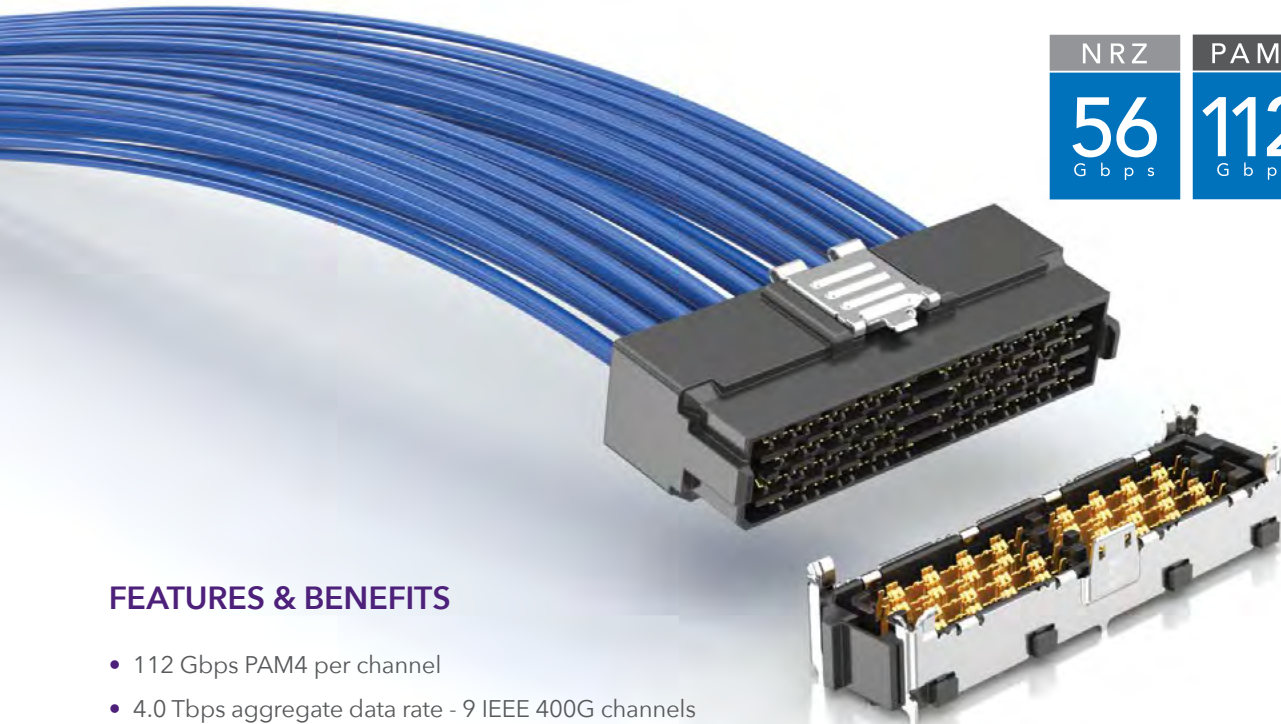

NRZ	PAM4
56 Gbps	112 Gbps

FEATURES & BENEFITS

- 112 Gbps PAM4 per channel
- 4.0 Tbps aggregate data rate - 9 IEEE 400G channels
- Innovative, fully shielded differential pair design enables extremely low crosstalk (to 40 GHz) and tight impedance control
- 112 differential pairs per square inch
- 34 AWG ultra-low skew twinax cable
- 92 Ω solution addresses both 85 Ω and 100 Ω applications
- Industry leading aggregate data rate density - 2x the data rate in 60% of the space
- 8 to 32 differential pairs; up to 72+ pairs in development
- Panel I/O solution in development



Two reliable points of contact guaranteed

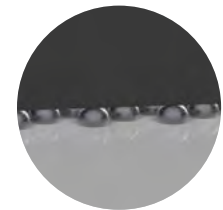

BGA attach for density and optimized trace breakout region

Aggregate Data Rate (NRZ)						
448 Gbps	672 Gbps	896 Gbps		1344 Gbps	1792 Gbps	4032 Gbps*
1 Bank			2 Bank			3 Bank*
2 Row	3 Row	4 Row	2 Row	3 Row	4 Row	6 Row*
8 Pairs	12 Pairs	16 Pairs		24 Pairs	32 Pairs	72 Pairs*
*In development						

EXTREME DENSITY & PERFORMANCE SYSTEM

NVAC	STYLE	CABLE STYLE	NO. OF ROWS	NO. OF BANKS	CABLE LENGTH	01	PIN OUT	OPTION
------	-------	-------------	-------------	--------------	--------------	----	---------	--------

-DP
= 4 pairs
per wafer

-1
= 34 AWG,
100 Ω Cable

-3
= 34 AWG,
92 Ω Cable

-02
= 2 Rows

-03
= 3 Rows

-04
= 4 Rows

-1
= 1 Bank

-2
= 2 Banks

-"XX.X"
= Length in inches
(152.4 mm) 06.0"
minimum

-1
= Pin A01
to Pin AN

-L
= Latch

NVAC
Board Mates:
NVAM-C



NO. OF BANKS	C
-1	(20.25) .797
-2	(36.25) 1.427

ROWS	A	B
-02	(4.40) .173	(7.30) .287
-03	(6.20) .244	(9.10) .358
-04	(8.00) .315	(10.90) .429

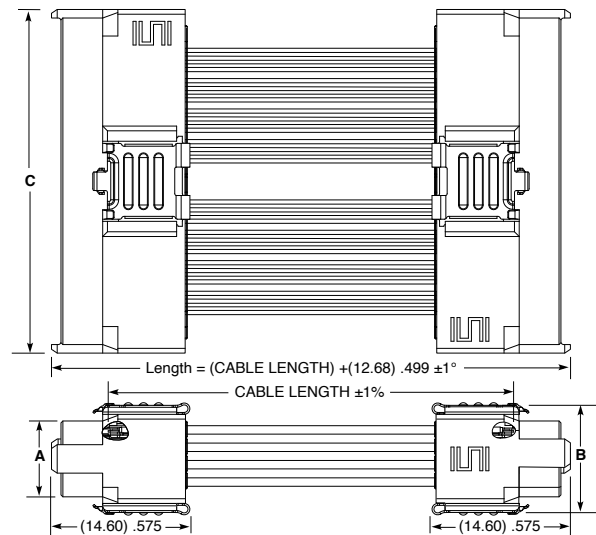

PRELIMINARY

Notes:
Cable lengths longer than
40.00" (1 meter) are not
supported with S.I. test data.

View complete specifications at: samtec.com?NVAC

NVAM	STYLE	NO. OF ROWS	NO. OF BANKS	02.0	PLATING OPTIONS	SOLDER TYPE	C
------	-------	-------------	--------------	------	-----------------	-------------	---

-DP
= 4 pairs
per wafer

-02
= 2 Rows

-03
= 3 Rows

-04
= 4 Rows

-1
= 1 Bank

-2
= 2 Banks

-S
= 30 μm (0.76 μm)
Gold on contact area,
Matte Tin on solder tail

-2
= Lead-Free
Solder Charge

NVAM-C
Cable Mates:
NVAC

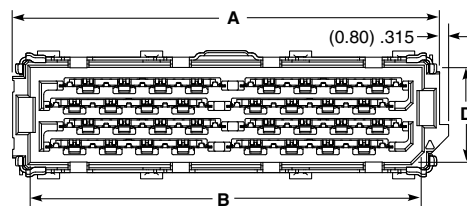

NO. OF BANKS	A	B	C
-1	(21.75) .856	(18.65) .734	(20.25) .797
-2	(37.75) 1.486	(34.65) 1.364	(36.25) 1.427

NO. OF ROWS	D	E	F
-02	(4.80) .189	(5.25) .207	(7.70) .303
-03	(6.60) .260	(7.05) .278	(9.50) .374
-04	(8.40) .331	(8.85) .348	(11.30) .445

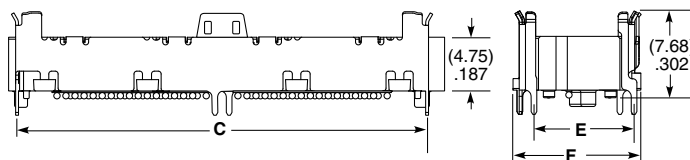

PRELIMINARY

Note:
Some sizes, styles and
options are non-standard,
non-returnable.

View complete specifications at: samtec.com?NVAM-C

ACCELERATE[®]

SLIM, DIRECT ATTACH CABLE ASSEMBLIES

(0.635 mm) .025" PITCH



NRZ	PAM4
28 Gbps	56 Gbps

FEATURES & BENEFITS

- Slimmest cable assembly in the industry - 7.6 mm width
- High-density 2-row design
- 8 and 16 differential pair configurations (24 pair in development)
- 34 AWG, 100 Ω Eye Speed[®] ultra low skew twinax cable
- Mating board level socket (ARF6 Series) features standard rugged weld tabs for increased stability on the PCB
- Rugged metal latching and shielding
- Supports 56 Gbps PAM4 (28 Gbps NRZ) applications
- Utilizes Samtec's Flyover[®] Technology to simplify board layout and extend signal reach

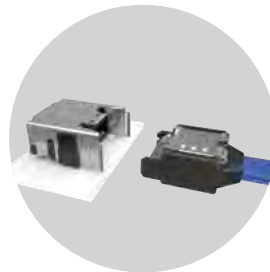

Right-angle available.
Visit [samtec.com?ARF6-RA](https://www.samtec.com?ARF6-RA)
for specifications.



Two rows of high-density
contacts directly
soldered to the cable

KEY SPECIFICATIONS

PITCH	CABLE	SIGNAL ROUTING	INSULATOR MATERIAL	CONTACT MATERIAL	PLATING	OPERATING TEMP RANGE
(0.635 mm) .025"	34 AWG Eye Speed [®] ultra low skew twinax	100 Ω Differential	Black LCP	Copper Alloy	Au or Sn over 50 μ " (1.27 μ m) Ni	-40 °C to +125 °C

(0.635 mm) .025" • SLIM CABLE & SOCKET

ARC6	NO OF PAIRS	CABLE LENGTH	END 1	END 2	WIRING OPTION	CABLE TYPE
	-08 -16 -24	-"XX.X" = Length in Inches 03.0" (76.2 mm) minimum	-LU = Latch Up	-LU = Latch Up -LD = Latch Down	-2 = Pin 1 to Pin 2 (End 2 -LD option only) -3 = Pin 1 to Pin N-1 (End 2 -LU option only)	-1 = 34 AWG 100 Ω Eye Speed®

ARC6
Board Mates:
ARF6

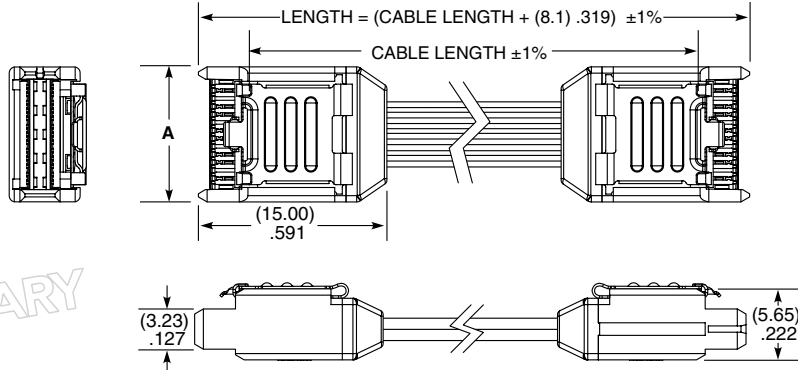

ARC6-08-XX.X-LU-LU-3-1 SHOWN

Notes:
Cable lengths longer than 40.00" (1 meter) are not supported with S.I. test data.

NO. OF PAIRS	A	N	N-1
-08	(10.90) .429	26	25
-16	(18.52) .729	50	49
-24	(26.14) 1.029	74	73

View complete specifications at: samtec.com?ARC6

ARF6	NO. OF PAIRS	PLATING	ROW	A	K	"X"R
	-08 -16 -24	-S = 30 μ" (0.76 μm) Gold on contact area, Matte Tin on tail	-D = Double Row	-A = Alignment Pin	-K = Polyimide film Pick & Place Pad	-TR = Tape & Reel -FR = Full Reel Tape & Reel (must order maximum quantity per reel; contact Samtec for quantity breaks)

ARF6
Cable Mates:
ARC6

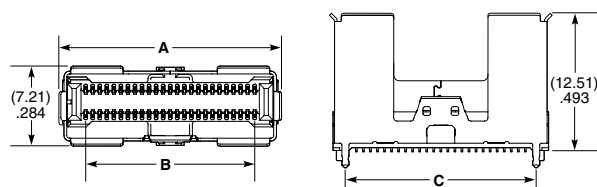
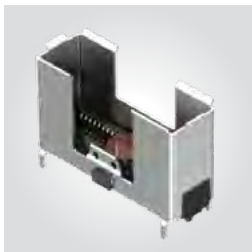

ARF6-16-L-D-A SHOWN

NO. OF PAIRS	A	B	C
-08	(12.46) .491	(7.62) .300	(9.59) .378
-16	(20.08) .791	(15.24) .600	(17.21) .678
-24	(27.70) 1.091	(22.86) .900	(24.83) .978

Notes:
Tape & Reel packaging and K-Dot are standard.

Some sizes, styles and options are non-standard, non-returnable.

View complete specifications at: samtec.com?ARF6



112 Gbps PAM4, LOW-PROFILE HIGH-DENSITY CABLE SYSTEM

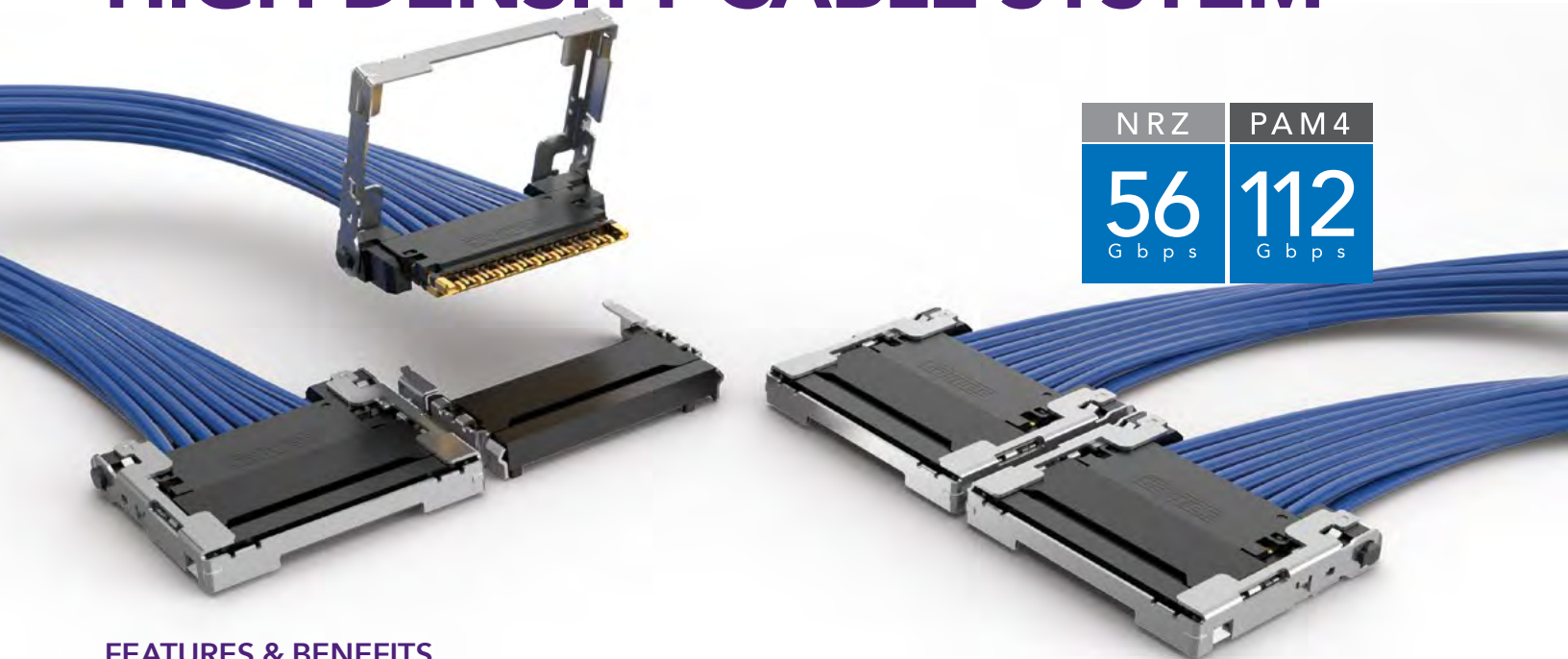

NRZ	PAM4
56 Gbps	112 Gbps

FEATURES & BENEFITS

- Ultra-high density configuration adjacent to the IC package
- Up to 16 pairs in an incredibly low 3.4 mm profile
- An extremely low profile allows Si-Fly™ connectors to reside under heat sinks or other cooling hardware
- Co-packaged interconnect option eludes the BGA and routes signals from the silicon package through a long-reach cable, supporting 5x the signal reach of traditional PCB solutions
- Extreme channel performance enabling 25.6 TB aggregate with a path to 51.2 TB
- 112 Gbps PAM4 per lane

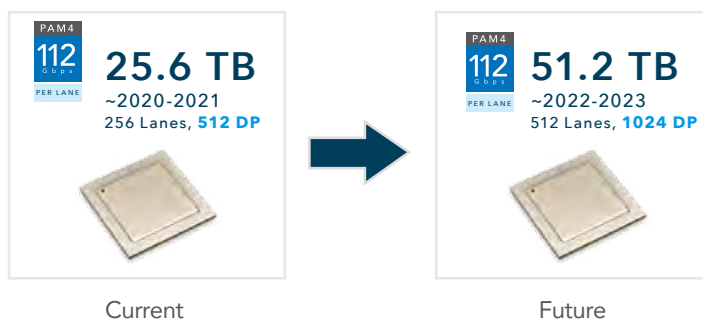

Roadmap:
Co-packaged interconnect configuration for advanced 112G+ data rate requirements



In development: Rugged latching configuration provides a secure connection directly adjacent to the IC package for increased signal integrity performance

KEY SPECIFICATIONS

CABLE	SIGNAL ROUTING	INSULATOR MATERIAL	CONTACT MATERIAL	PLATING
34 AWG ultra low skew twinax	92 Ω	Black LCP	Copper Alloy	Au or Sn over 50 μ" (1.27 μm) Ni

0.6 mm CO-PACKAGED CABLE & INTERCONNECT

CPC	STYLE	CABLE STYLE	CABLE LENGTH	END 2	WIRING OPTION
	-01 = 8 Pairs	-1 = 34 AWG ultra low skew twinax cable	-"XX.X" = Wire Length in Inches 06.0" (152.4 mm) minimum	-02 = CPC to CPC	-1 = Pin 1 to Pin 16 -2 = Pin 1 to Pin 1

CPC

Board Mates:
CPI



PRELIMINARY

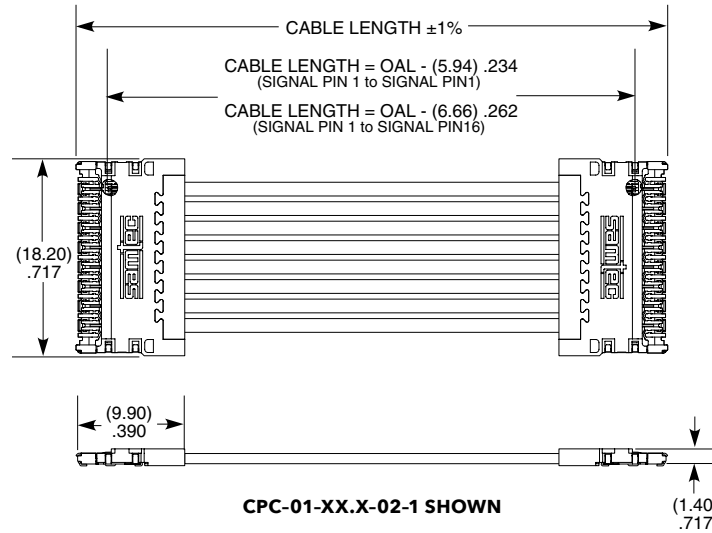

Notes:

Latching configuration not shown. Currently in development.

Cable lengths longer than 40.00" (1 meter) are not supported with S.I. test data.

View complete specifications at: samtec.com?CPC

CPI	NO OF POSITIONS	LEAD STYLE	ROW	PLATING OPTION	RA	SOLDER TYPE	WELD TAB
	-025 (Per Row) (8 Differential Pairs)	-01 = Surface Mount -02 = Overhang Mount	-1 = 1 Row -2 = 2 Row	-H = 30 μ " (0.76 μ m) Gold on contact area, Tin on tail		-2 = Lead-Free Solder Ball	-1 = Surface Mount

CPI

Cable Mates:
CPC



PRELIMINARY

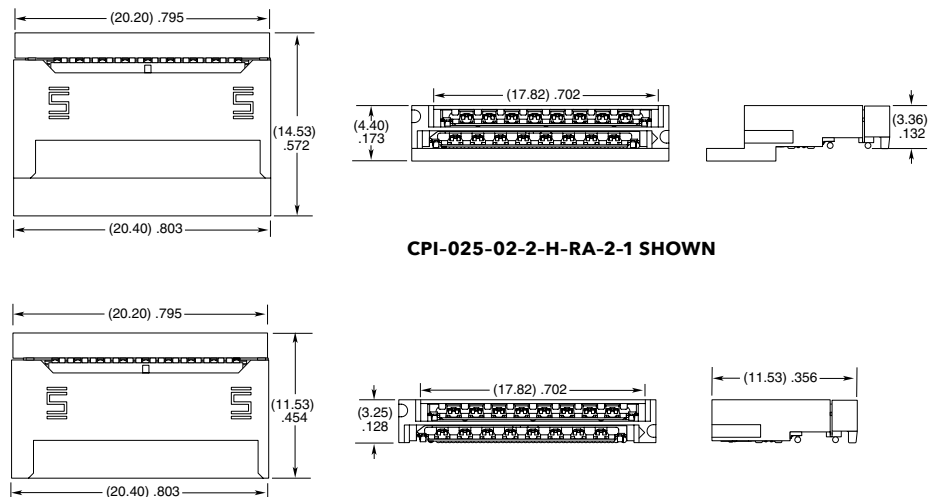

Note:

Some lengths, styles and options are non-standard, non-returnable.

View complete specifications at: samtec.com?CPI



HIGH-DENSITY COPPER FLYOVER[®] SYSTEM



FEATURES & BENEFITS

- Pin compatible with optical FireFly™ using the same connector system
- Data connection is taken "off board" for easier routing
- Low-cost solution for seamless integration of new and existing designs
- Low-profile housing for space savings
- x4 bidirectional or x12 unidirectional
- Variety of end 2 termination options

14 G b p s	x4 Bidirectional ECUE x12 Unidirectional ECUE
PAM 4	
56 G b p s	x4 Bidirectional ECUE-2



Standard Copper (ECUE)

- 14 Gbps
- 100 Ω, 34 AWG or 36 AWG Eye Speed[®] twinax cable



Optimized Copper (ECUE-2)

- 28 Gbps card design
- 100 Ω, 34 AWG Eye Speed[®] ultra low skew twinax cable
- Optimized for use with connector UEC5-2



PCI Express[®]-Over-FireFly[™] Copper (PCUE)

- PCIe[®] 4.0
- 100 Ω, 34 AWG Eye Speed[®] ultra low skew twinax cable
- Optimized for use with connector UEC5-2

LOW-PROFILE MICRO FLYOVER® CABLE

SERIES	NO OF PAIRS	ASSEMBLY LENGTH	CABLE TYPE	END 2 OPTION	WIRING OPTION	DATA RATE	OPTION
ECUE = Rugged FireFly™ Cable Assembly	-08 = Eight Pair (-T2 & -T3 cable only) -12 = Twelve Pair (-T1 cable only)	-"XXX" = Assembly Length in Centimeters (007 cm to 999 cm)	-T1 = 36 AWG twinax (-12 pairs only) -T2 = 34 AWG twinax (-08 pairs only) -T3 = 34 AWG ultra low skew twinax (-08 pairs only)	-FF = FireFly™ (Mates with UEC5/UCC8)	-01 = Pin A1 to Pin A19 -02 = Pin A1 to Pin B1 -B4 = Pin A1 to Pin B19 (-08 pair only)	-1 = 14 Gbps (-T1 or -T2 only) -2 = 28 Gbps (-T3 only)	Leave blank for standard FireFly™ -D1 = Decoupling Capacitors (only available with -02 & -B4 wire options)

ECUE
Board Mates:
UEC5, UCC8

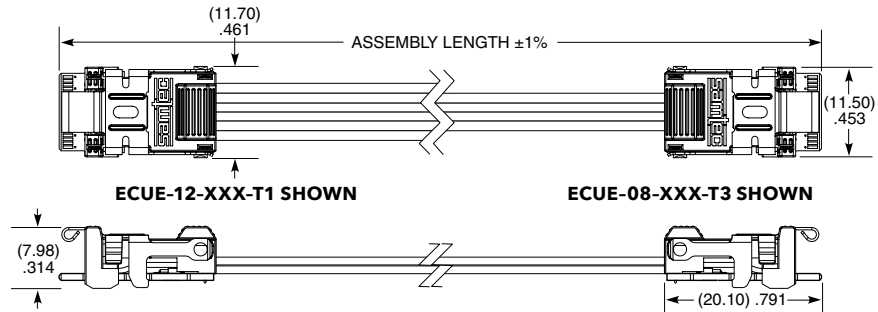
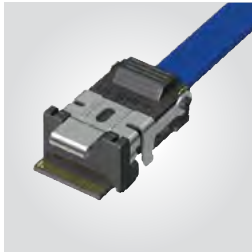

Notes:
All FireFly™ designs, specifications and components are preliminary and subject to change without notice.

Cable lengths longer than 150 cm (59.06") are not supported with S.I. test data.

View complete specifications at: samtec.com?ECUE

SERIES	SPEED	NO. OF CHANNELS	CABLE LENGTH	END 2
PCUE = PCIe®-over-FireFly™ Copper Flyover®	-G4 = Gen 4 Speed	-04 = 8 pairs	-"XXX" = Overall Length in Centimeters (010 cm to 999 cm)	-FF = FireFly™ (Mates with UEC5/UCC8)

PCUE
Board Mates:
UEC5, UCC8

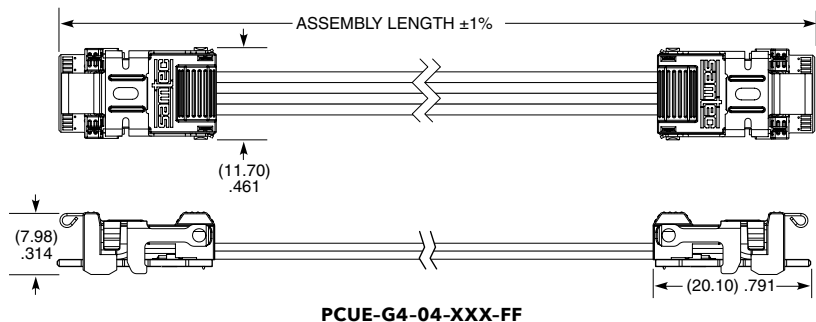

Notes:
Supports PCIe® sideband signals

Two additional low speed channels compatible with PCUO or custom usage

Decoupling capacitors in-line with signals on PCB.

PCI-SIG®, PCI Express® and the PCIe® design marks are registered trademarks and/or service marks of PCI-SIG.

Some sizes, styles and options are non-standard, non-returnable.

View complete specifications at: samtec.com?PCUE

RUGGED MICRO FLYOVER® SOCKET SYSTEM

UEC5	NO. OF POSITIONS	DATA RATE	PLATING OPTION	D	RA	WELD TAB	OPTION	PACKAGING
	-019 (Per Row)	-1 = Up to 16 Gbps -2 = 28 Gbps+	-H = 30 μ" (0.76 μm) Gold on contact, Gold flash on tail (-1 Data Rate only) -H = 30 μ" (0.76 μm) Gold on contact, Matte Tin on tail (-2 Data Rate only)			-1 = Through-hole -2 = Surface Mount (Data Rate -1 only)	Leave blank for -2 Data Rate -A = Alignment Pin (Available with Data Rate -1 only)	Leave blank for Tape & Reel -FR = Full Reel Tape & Reel (must order max. quantity per reel; contact Samtec for quantity breaks)

UEC5

Board Mates:

ECUE, ECUO, PCUO, PCUE, ETUO

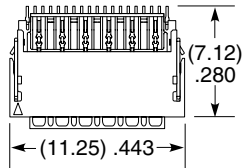

UEC5-019-2-X-D-RA-1

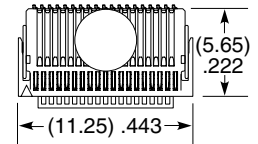
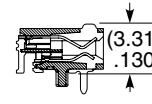
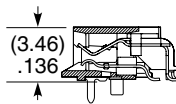

UEC5-019-1-X-D-RA-1-A

Note:

PCB footprints are not interchangeable for -1 and -2 data rate versions.

View complete specifications at: samtec.com?UEC5-1 & samtec.com?UEC5-2

UCC8	NO. OF POSITIONS	1	PLATING OPTION	S	WELD TAB	A	PACKAGING
------	------------------	---	----------------	---	----------	---	-----------

-010

-H
= 30 μ" (0.76 μm)
Gold on contact,
Gold flash on tail

-1
= Through-hole

Leave blank for Tape & Reel

-FR
= Full Reel Tape & Reel
(must order max. quantity per reel; contact Samtec for quantity breaks)

UCC8

Board Mates:

ECUE, ECUO, PCUO, PCUE, ETUO

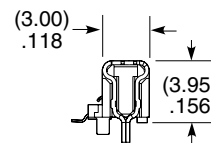
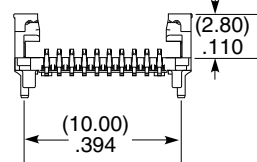
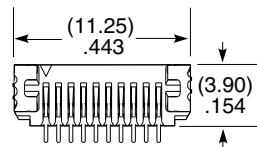

Note:

Some sizes, styles and options are non-standard, non-returnable.

View complete specifications at: samtec.com?UCC8

HIGH-SPEED EDGE CARD CABLE & SOCKET

(0.50 mm) .0197" PITCH • FEDP/FCDP SERIES

16
Gbps

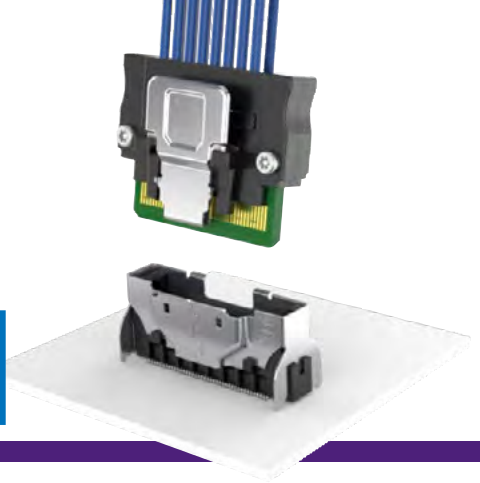

FEDP

Mates:
FCDP-DV, FCDP-RA

SPECIFICATIONS

Cable:
34 AWG Eye Speed®
ultra low skew twinax

Signal Routing:
100 Ω

Operating Temp Range:
-40 °C to +125 °C

Current Rating:
1.3 A per pin
(2 pins powered)



FEDP	NO. OF PAIRS	CABLE LENGTH	END 1	END 2	CABLE TYPE
------	--------------	--------------	-------	-------	------------

-16	-"XX.X" = Length in Inches 06.0" (152.4 mm) minimum	-LU = Latch Up	-LU = Latch Up	-LD = Latch Down	-1 = 34 AWG 100 Ω Eye Speed®
-----	--	-------------------	-------------------	---------------------	---------------------------------------

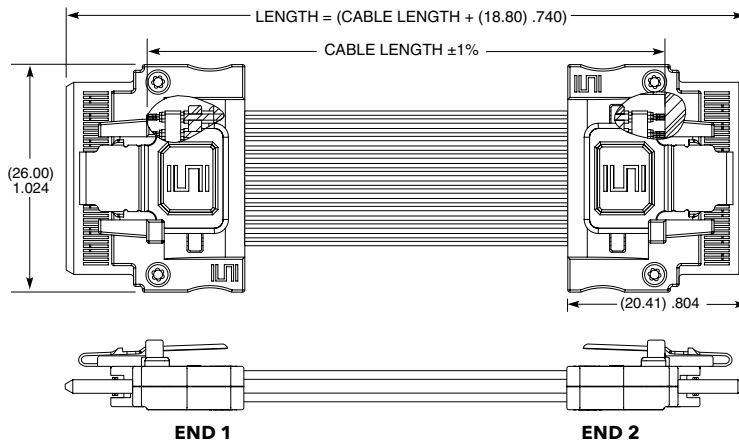

FEDP-16-XX.X-LU-LU-1 SHOWN

Note:
For speeds up to 28G NRZ/56G PAM4, FEDP must be paired with FQSFP and FQSFP-DD. Contact hdr@samtec.com for more information.

Some sizes, styles and options are non-standard, non-returnable.

FCDP

Mates:
FEDP

SPECIFICATIONS

Insulator Material:
Black LCP

Contact Material:
Copper Alloy

Plating:
Au or Sn over
50 μ" (1.27 μm) Ni

Shield Material:
Copper Alloy

Current Rating:
1.3 A per pin
(2 pins powered)

FCDP	NO. OF PAIRS	01	PLATING OPTION	ROW	OPTION
------	--------------	----	----------------	-----	--------

-16	-L = 10 μ" (0.25 μm) Gold on contact, Matte Tin on tail	-DV = Double Vertical	-S = 30 μ" (0.76 μm) Gold on contact, Matte Tin on tail (Not available with -RA)	-RA = Right-angle	(-DV only) -S1 = Latch opposite pin 1 -S2 = Latch toward pin 1
-----	--	--------------------------	--	----------------------	--

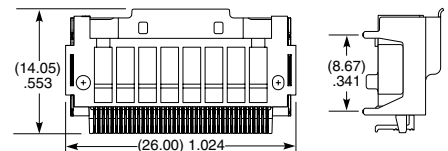
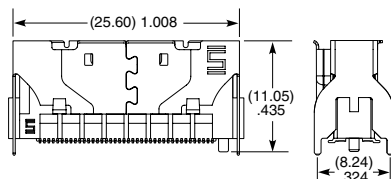
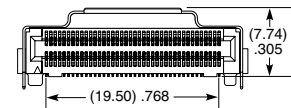
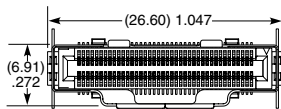

FCDP-16-01-X-DV-S1 SHOWN

FCDP-16-01-L-RA SHOWN

Note:
Some sizes, styles and options are non-standard, non-returnable.

TWINAX EDGE CARD CABLE ASSEMBLY

(0.80 mm) .0315" PITCH • ECDP SERIES

14
Gbps



ECDP

Mates:
HSEC8 (-L2 option),
HSEC8 (-BL option)

SPECIFICATIONS

Cable:
30 AWG twinax cable
Plating:
Edge Card = ENIG,
3-10 microinches
Operating Temp Range:
-25 °C to +105 °C
Current Rating:
2.3 A per pin
(2 adjacent pins powered)
Impedance:
100 Ω Differential
Bend Radius:
(3.18 mm) .125"
Pinout Map:
See web address below

ECDP	NO. OF PAIRS	WIRE LENGTH	END 1	END 2	WIRING OPTION	CABLE TYPE
	-04, -08, -16, -32	-"XX.XX" = Wire Length in Inches (95.3 mm) 03.75" minimum	-L1 = Double Vertical with latches -B1 = Board lock, No housing	-L1 = Double Vertical with latches (Wiring option -3 & -4 only) -L2 = Double Vertical with latches (Wiring option -1 & -2 only) -B1 = Board lock, No housing (Wiring option -3 & -4 only) -B2 = Board lock, No housing (Wiring option -1 & -2 only)	-1 = Pin 1 to Pin 1 -2 = Pin 1 to Pin 2 -3 = Pin 1 to Pin N-1 -4 = Pin 1 to Pin N	-3 = 100 Ω Eye Speed [®]

NO. OF PAIRS	A
-04	(20.85) .821
-08	(24.05) .947
-16	(33.66) 1.325
-32	(52.86) 2.081

CABLE	CONNECTOR
ECDP-04	HSEC8-109-XX
ECDP-08	HSEC8-113-XX
ECDP-16	HSEC8-125-XX
ECDP-32	HSEC8-149-XX

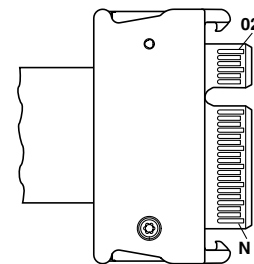
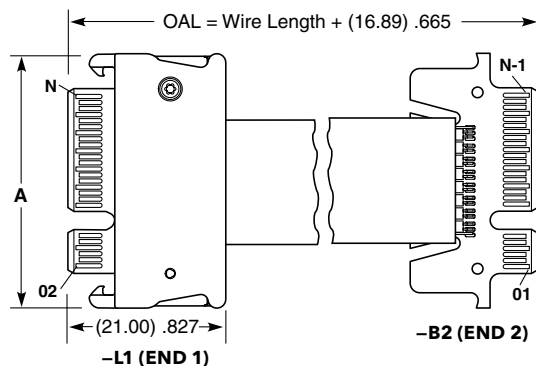

Notes:

Cable lengths longer than 40.00" (1 meter) are not supported with S.I. test data.

Design your full cable assembly with Samtec's High-Speed Cable Builder at www.samtec.com/cablebuilder

Some lengths, styles and options are non-standard, non-returnable.

*Same pinout for -B1 end 2 and -L1 end 2.



Q PAIRS® TWINAX CABLE ASSEMBLIES

14
Gbps



(0.50 mm) .0197" & (0.80 mm) .0315" PITCH • HQDP/EQDP SERIES

EQDP

Mates:
QTE-DP, QSE-DP

HQDP

Mates:
QTH-DP, QSH-DP

SPECIFICATIONS

Cable:
30 AWG twinax ribbon
Signal Routing:
100 Ω Differential
Cable Bending Radius:
(3.18 mm) 1/8" min
Plating:
Au over 50 μ" (1.27 μm) Ni
Current Rating:
EQDP = 500 mA per pin
HQDP = 400 mA per pin
(6 adjacent pins powered)
Propagation Delay:
4.67 nsec/meter
Operating Temp Range:
-25 °C to +105 °C
Skew (pair-to-pair):
<10 ps/ft
Skew (within a pair):
<5 ps/ft
EMI Performance:
FCC Class A

SERIES	NO. OF PAIRS	WIRE LENGTH	END NO. 1	END NO. 2	WIRING OPTION	SCREW OPTION
HQDP = (0.50 mm) .0197" pitch	-020, -040, -060 (20 pairs per bank) HQDP Series	-"XX.XX" = Wire Length in Inches (43.7 mm) 01.72" minimum	Specify END ASSEMBLIES from chart		-5 = Pin 1 to Pin 1	Leave blank for no Screw Option
EQDP = (0.80 mm) .0315" pitch	-014, -028, -042 (14 pairs per bank) EQDP Series	-6 = Pin 1 to Pin 2			-F = End No. 1	
					-7 = Pin 1 to Second Last Pin	-S = End No. 2
					-8 = Pin 1 to Last Pin	-B = Both Ends

END	SURFACE MOUNT
TTR	Terminal, Top, Notch Right
TTL	Terminal, Top, Notch Left
TBR	Terminal, Bottom, Notch Right
TBL	Terminal, Bottom, Notch Left
STR	Socket, Top, Notch Right
STL	Socket, Top, Notch Left
SBR	Socket, Bottom, Notch Right
SBL	Socket, Bottom, Notch Left

END	EDGE MOUNT
TEU	Terminal, Edge, Notch Up
TED	Terminal, Edge, Notch Down
SEU	Socket, Edge, Notch Up
SED	Socket, Edge, Notch Down

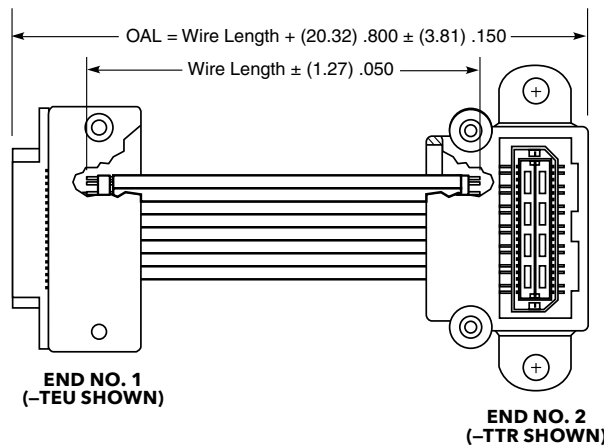
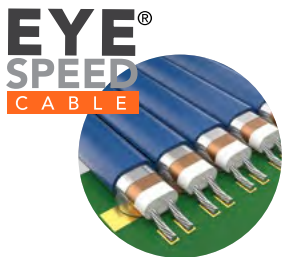

WIRING REQUIREMENTS	
WIRING OPTION	END OPTIONS
5 or 6	TTR, TBL, STL, SBR, TEU, SED to TTR, TBL, STL, SBR, TED, SEU or TTL, TBR, STR, SBL, TED, SEU to TTL, TBR, STR, SBL, TEU, SED
7 or 8	TTR, TBL, STL, SBR, TEU, SED to TTL, TBR, STR, SBL, TEU, SED or TTL, TBR, STR, SBL, TED, SEU to TTR, TBL, STL, SBR, TED, SEU

Notes:
Cable lengths longer than
40.00" (1 meter) are not
supported with S.I. test data.

Design your full cable
assembly with Samtec's
High-Speed Cable Builder at
www.samtec.com/cablebuilder

This Series is non-standard,
non-returnable.

EDGE RATE® TWINAX CABLE ASSEMBLIES

14
Gbps

(0.80 mm) .0315" PITCH • ERDP SERIES



ERDP

Mates:
ERF8 (-L), ERM8 (-L)
(Mating connectors require latching option -L)

SPECIFICATIONS

Cable:
30 AWG twinax ribbon cable
Signal Routing:
100 Ω Differential
Plating:
Au over 50 μ" (1.27 μm) Ni
Operating Temp Range:
-25 °C to +105 °C

ERDP	NO. POSITIONS PER ROW	WIRE LENGTH	END NO. 1	END NO. 2	WIRING OPTION	LATCH
------	-----------------------	-------------	-----------	-----------	---------------	-------

-013
= 8 Pair
-025
= 16 Pair
-049
= 32 Pair

-"XX.XX"
= Wire Length in Inches (43.7 mm) 01.72" minimum

-TTR
= Terminal, Top Right

-TTL
= Terminal, Top Left

-TBR
= Terminal, Bottom Right

-TBL
= Terminal, Bottom Left

-STR
= Socket, Top Right

-STL
= Socket, Top Left

-SBR
= Socket, Bottom Right

-SBL
= Socket, Bottom Left

-TEU
= Terminal, Edge Mount Up

-TED
= Terminal, Edge Mount Down

-5
= Pin 1 to Pin 1

-6
= Pin 1 to Pin 2

-7
= Pin 1 to Pin N-1

-8
= Pin 1 to Pin N

Specify LATCH from chart (Required callout)

POSITIONS PER ROW	A
-013	(25.86) 1.018
-025	(34.67) 1.365
-049	(53.85) 2.120

END TO END	B
DV to DV	(23.47) .924
DV to Edge Mount (-TEX)	(26.69) 1.051
Edge Mount (-TEX)	(29.92) 1.178

**EYE
SPEED
CABLE**

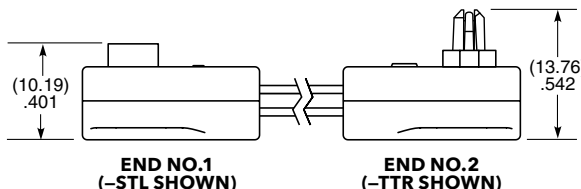
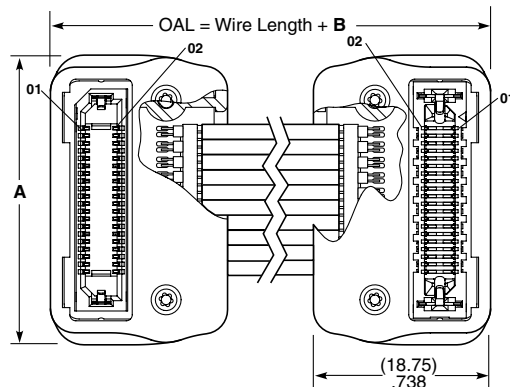
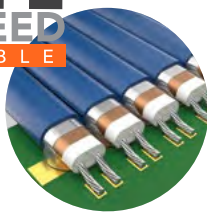

Notes:
Cable lengths longer than 40.00" (1 meter) are not supported with S.I. test data.

Design your full cable assembly with Samtec's High-Speed Cable Builder at www.samtec.com/cablebuilder

Some lengths, styles and options are non-standard, non-returnable.

LATCH	ASSEMBLY
† -L	End No. 1 Standard Latch, End No. 2 Squeeze Latch
◆ -R	End No. 1 Squeeze Latch, End No. 1 Standard Latch
-D	Both Ends Standard Latch
-N	No Housing Both Ends Standard Latch
* -B	Both Ends Squeeze Latch
◆ -F	End No. 1 Screw Option, End No. 2 Friction Latch
† -S	End No. 1 Friction Latch, End No. 2 Screw Option
* -C	Both Ends Screw Option
* -G	End No. 1 Screw Option, End No. 2 Squeeze Latch
* -T	End No. 1 Squeeze Latch, End No. 2 Screw Option

* -B, -C, -G & -T option only available with -TEX on both ends.
† -L & -S option only available with -TEX on second end.
◆ -R & -F option only available with -TEX on first end.

HIGH-SPEED HERMAPHRODITIC CABLE

(0.50 mm) .0197" PITCH • HLCD SERIES



HLCD
Mates:
 LSHM

SPECIFICATIONS

Cable:
 38 AWG 50 Ω coax cable
Signal Routing:
 50 Ω Single-Ended
Plating:
 Au over 50 μ" (1.27 μm) Ni
Operating Temp Range:
 -25 °C to +105 °C
Current Rating:
 0.9 A per pin
 (2 pins powered)

HLCD	POSITIONS PER ROW	WIRE LENGTH	END NO. 1	END 1 OPTION	END NO. 2	END 2 OPTION	WIRING OPTION
	-20, -30, -40, -50 (Standard sizes)	-"XX.XX" = Wire Length in Inches (43.7 mm) 01.72" minimum	-TR = Vertical, Top Right	Leave blank for no screw down. Screw down not available for -TD, -TH, -BD & -BH options.	-TR = Vertical, Top Right	Leave blank for no screw down. Screw down not available for -TD -TH, -BD & -BH options.	-1 = Pin 1 to Pin 1
			-TL = Vertical, Top Left		-TL = Vertical, Top Left		-2 = Pin 1 to Pin 2
			-BR = Vertical, Bottom Right	S = Screw down in PCB	-BR = Vertical, Bottom Right	S = Screw down in PCB	-3 = Pin 1 to Pin N-1
			-BL = Vertical, Bottom Left		-BL = Vertical, Bottom Left		-4 = Pin 1 to Pin N
			-TD = Right- angle, Top		-TD = Right- angle, Top		
			-TH = Reversed Right- angle, Top		-TH = Reversed Right- angle, Top		
			-BD = Right- angle, Bottom		-BD = Right- angle, Bottom		
			-BH = Reversed Right- angle, Bottom		-BH = Reversed Right- angle, Bottom		

END TO END	A
Vertical to Vertical	(21.84) .860
Vertical to Right-angle	(25.35) .998
Vertical to Reversed Right-angle	
Right-angle to Right-angle	
Right-angle to Reversed Right-angle	(28.85) 1.136
Reversed Right-angle to Reversed Right-angle	

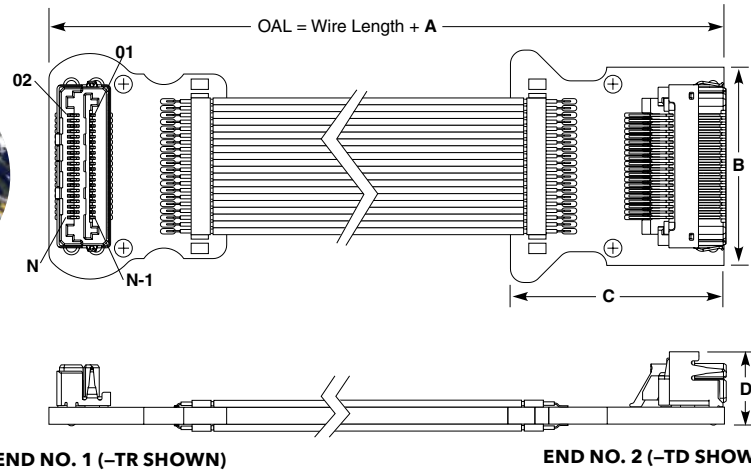
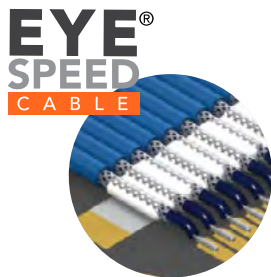

POSITIONS PER ROW	B	
	XR, XL	XH, XD
-20	(22.23) .875	(18.42) .725
-30	(24.77) .975	(26.04) 1.025
-40	(32.39) 1.275	(33.66) 1.325
-50	(40.01) 1.575	(41.28) 1.625

END OPTION	C	D
XL, XR	(16.51) .650	(6.02) .237
XD	(20.02) .788	(6.71) .264
XH		

Notes:
 Cable lengths longer than 40.00" (1 meter) are not supported with S.I. test data.
 Design your full cable assembly with Samtec's High-Speed Cable Builder at www.samtec.com/cablebuilder
 Some lengths, styles and options are non-standard, non-returnable.



Q STRIP® COAX CABLE ASSEMBLIES

14
Gbps

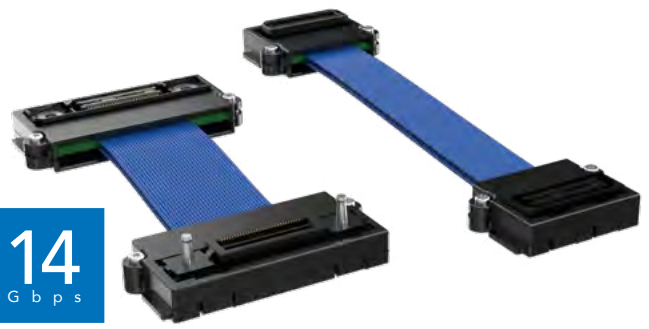

(0.50 mm) .0197" & (0.80 mm) .0315" PITCH • HQCD/EQCD SERIES

HQCD
Mates:
QTH, QSH

EQCD
Mates:
QTE, QSE

SPECIFICATIONS

Cable:
38 AWG micro coax ribbon
Signal Routing:
50 Ω Single-Ended
Overall Length:
(95.3 mm) 03.75" to
(1 m) 40" standard
Cable Flexing Life:
>10,000 cycles
Cable Bending Radius:
<2.5mm
Plating:
Au over 50 μ" (1.27 μm) Ni
Current Rating:
EQCD = 500 mA per pin
HQCD = 300 mA per pin
(6 adjacent pins powered)
Cable Propagation Delay:
4.79 nsec/meter
Operating Temp Range:
-25 °C to +105 °C
Unmating Force (-RT1 option):
-RT1 option increases
unmating force up to 50%

SERIES	NO. OF POSITIONS PER ROW	WIRE LENGTH	END NO. 1	END NO. 2	WIRING OPTION	END OPTIONS
HQCD = (0.50 mm) .0197" pitch	-030, -060, -090 (HQCD Series)	-"XX.XX" = Wire Length in Inches (43.7 mm) 01.72" minimum	Specify END ASSEMBLIES from chart		-1 = Pin 1 to Pin 1 -2 = Pin 1 to Pin 2 -3 = Pin 1 to Second to Last Pin -4 = Pin 1 to Last Pin	Leave blank for no Screw Mount & Retention End Option -F = Screw Mount End No. 1 only (Not available with XPX options) -S = Screw Mount End No. 2 only -B = Screw Mount Both Ends (Not available with XPX options)
EQCD = (0.80 mm) .0315" pitch	-020, -040, -060 (EQCD Series)					-1 = End No. 1 Screw Mount. End No. 2 Retention Pin or Socket -2 = End No. 1 Retention Pin or Socket. End No. 2 Screw Mount Option

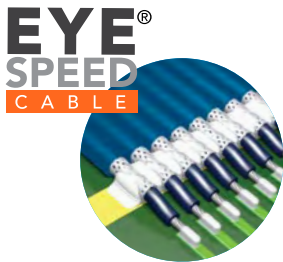
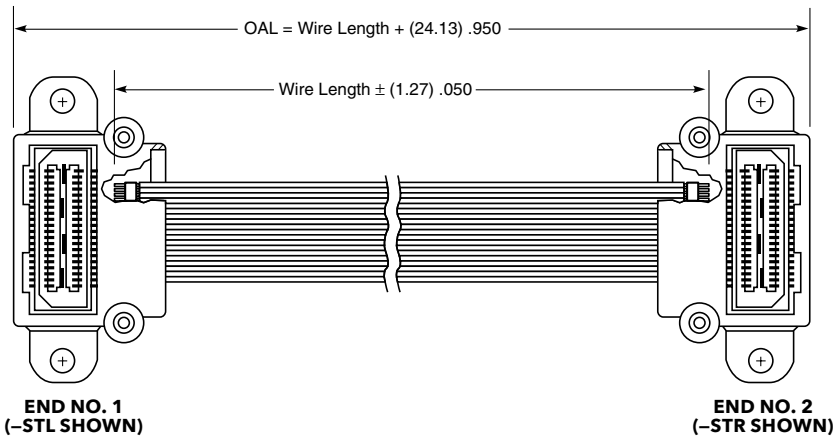

Notes:
Cable lengths longer than
40.00" (1 meter) are not
supported with S.I. test data.

Design your full cable
assembly with Samtec's
High-Speed Cable Builder at
www.samtec.com/cablebuilder

This Series is non-standard,
non-returnable.

END1 ONLY	PANEL MOUNT
TPU	Terminal, Panel Mount, Notch Up
TPD	Terminal, Panel Mount, Notch Down
SPU	Socket, Panel Mount, Notch Up
SPD	Socket, Panel Mount, Notch Down

END 1 or END 2	SURFACE MOUNT
TTR	Terminal, Top Mount, Notch Right
TTL	Terminal, Top Mount, Notch Left
TBR	Terminal, Bottom Mount, Notch Right
TBL	Terminal, Bottom Mount, Notch Left
STR	Socket, Top Mount, Notch Right
STL	Socket, Top Mount, Notch Left
SBR	Socket, Bottom Mount, Notch Right
SBL	Socket, Bottom Mount, Notch Left

EDGE RATE® CABLE ASSEMBLIES

14
Gbps

(0.80 mm) .0315" PITCH • ERCD SERIES



ERCD

Mates:

ERF8 (-L), ERM8 (-L)

(Mating connectors require latching option -L)

SPECIFICATIONS

Cable:

34 AWG coax ribbon cable

Signal Routing:

50 Ω Single-Ended

Plating:

Au over 50 μ" (1.27 μm) Ni

Operating Temp Range:

-25 °C to +105 °C

Current Rating:

1.3 A per pin
(2 pins powered)

OTHER SOLUTIONS

Q Rate® Cable Assemblies that mate to the QRF8, QRM8 Series.

For coax cable, visit the EQRD series located at www.samtec.com?EQRD



For twinax cable, visit the EQRP series located at www.samtec.com?EQRP

ERCD	NO. POSITIONS PER ROW	WIRE LENGTH	END NO. 1	END NO. 2	WIRING OPTION	LATCH
------	-----------------------	-------------	-----------	-----------	---------------	-------

-010, -013,
-020, -025,
-030, -040,
-050, -060

-“XX.XX”
= Wire Length
in Inches
(43.7 mm)
01.72”
minimum

-TTR
= Terminal,
Top Right

-TTL
= Terminal,
Top Left

-TBR
= Terminal,
Bottom Right

-TBL
= Terminal,
Bottom Left

-STR
= Socket,
Top Right

-STL
= Socket,
Top Left

-SBR
= Socket,
Bottom Right

-SBL
= Socket,
Bottom Left

-TEU
= Terminal,
Edge Mount Up

-TED
= Terminal,
Edge Mount Down

-1
= Pin 1 to
Pin 1

-2
= Pin 1 to
Pin 2

-3
= Pin 1 to Pin
N -1

-4
= Pin 1 to
Pin N

Specify
LATCH
from
chart
(Required
callout)

POSITIONS PER ROW	A
-010	(22.66) .892
-013	(25.06) .987
-020	(30.66) 1.207
-025	(34.65) 1.364
-030	(38.66) 1.522
-040	(46.66) 1.837
-050	(54.66) 2.152
-060	(62.66) 2.467

END TO END	B
DV to DV	(23.47) .924
DV to Edge Mount (-TEX)	(26.69) 1.051
Edge Mount (-TEX)	(29.92) 1.178

LATCH	ASSEMBLY
† -L	End No. 1 Standard Latch, End No. 2 Squeeze Latch
◆ -R	End No. 1 Squeeze Latch, End No. 2 Standard Latch
-D	Both Ends Standard Latch
-N	No Housing Both Ends Standard Latch
* -B	Both Ends Squeeze Latch
-F	End No. 1 Screw Option, End No. 2 Friction Latch
-S	End No. 1 Friction Latch, End No. 2 Squeeze Option
-C	Both Ends Screw Option
† -G	End No. 1 Screw Option, End No. 2 Squeeze Latch
◆ -T	End No. 1 Squeeze Latch, End No. 2 Screw Option

* -B option only available with
-TEX on both ends.
† -L & -S option only available with
-TEX on second end.
◆ -R & -T option only available with
-TEX on first end.

**EYE
SPEED**
CABLE

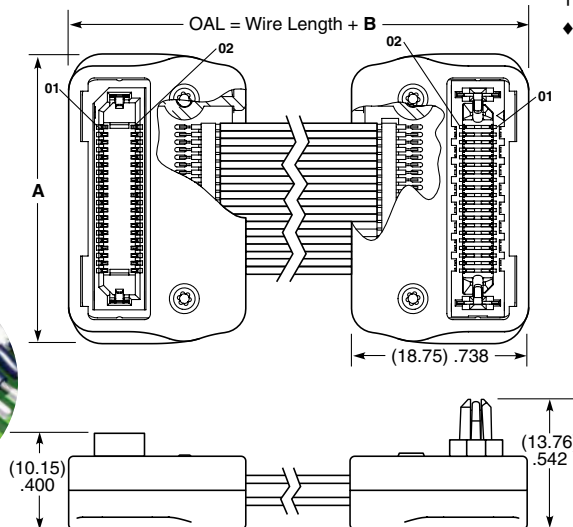

Notes:

Cable lengths longer than 40.00" (1 meter) are not supported with S.I. test data.

Design your full cable assembly with Samtec's High-Speed Cable Builder at www.samtec.com/cablebuilder

Some lengths, styles and options are non-standard, non-returnable.



HIGH-SPEED HIGH-DENSITY JUMPER

(1.27 mm) .050" PITCH • SEAC SERIES

14
Gbps



SEAC-N

Mates:
SE AFC, SE AF,
SE AF-RA, SE AFF

SEAC with latch posts

Mates:
SE AFC, SE AF-LP,
SE AF-RA-LP

SPECIFICATIONS

Cable:
36 AWG 50 Ω coax, or
32 AWG 100 Ω twinax
Signal Routing:
50 Ω Single-Ended, or
100 Ω Differential Pair
Plating:
Au over 50 μ" (1.27 μm) Ni
Operating Temp Range:
-40 °C to +125 °C (coax)
-25 °C to +105 °C (twinax)



SEAC	NO. OF POSITIONS PER ROW	NO. OF ROWS	CABLE LENGTH	TU	TU	CABLE TYPE	LATCH OPTION
	-020 (-04, -06, -08 & -10 row only)	-04, -06, -08, -10	- "XX.X" = Cable Length in Inches (152.4 mm) 06.0" minimum			Leave Blank for 36 AWG 50 Ω coax -2 = 32 AWG 100 Ω twinax	Leave Blank for latch post -N = No Latch
	-030 (-04, -06 & -08 row only)						
	-040 (-04 & -06 row only)						
	-050 (-04 row only)						

SIGNAL ROUTING

Product has some lines dedicated to ground.
For single-ended and differential pair signal/ground assignments see signal routing information on the assembly print at the web address above.
Design your High-Speed Cable with Samtec's High-Speed Cable Solutionator® at www.samtec.com/hdr

POSITIONS PER ROW	A	B	C
-020	(30.38) 1.196	(33.53) 1.320	(48.26) 1.900
-030	(43.08) 1.696	(46.23) 1.820	(60.96) 2.400
-040	(55.78) 2.196	(58.93) 2.320	(73.66) 2.900
-050	(68.48) 2.696	(71.63) 2.820	(86.36) 3.400

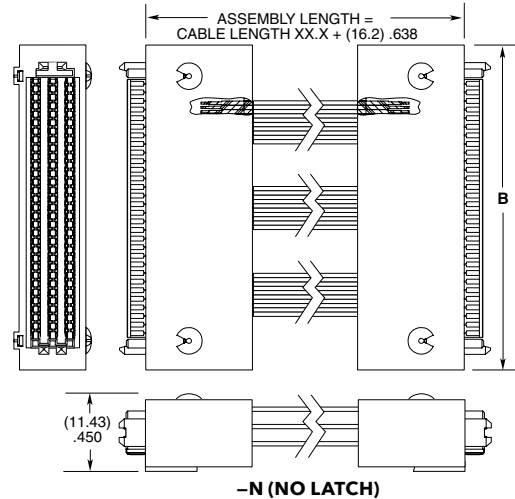

OTHER SOLUTIONS

Other end options
Mixed SEAC end types
300 positions or greater

Notes:
Mixed latch styles not available

Cable lengths longer than 40.00" (1 meter) are not supported with S.I. test data.

Design your full cable assembly with Samtec's High-Speed Cable Builder at www.samtec.com/cablebuilder

PCIe® 2.0 & 3.0 capable

PCI-SIG®, PCI Express® and the PCIe® design marks are registered trademarks and/or service marks of PCI-SIG.

Some lengths, styles and options are non-standard, non-returnable.

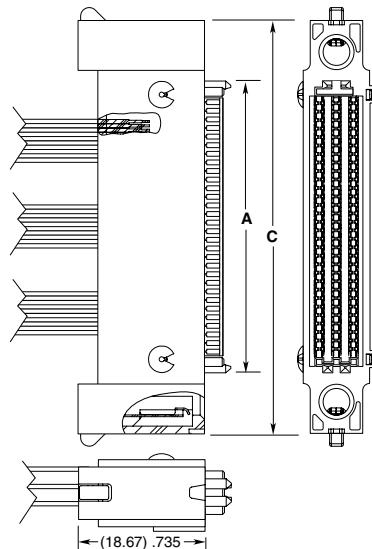

LATCH POST

SEARAY™ .8 mm CABLE ASSEMBLY

(0.80 mm) .0315" Pitch High-Speed Cable in 8 to 10 rows that mates with the SEAM8/SEAF8 Series.

For more information on the ESCA Series, visit samtec.com?ESCA

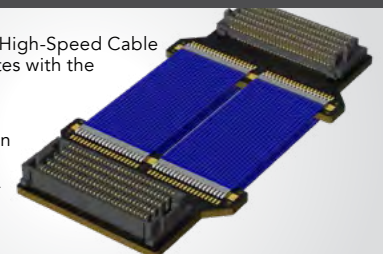

SEARAY™ MICRO COAX CABLE ASSEMBLY

(0.80 mm) .0315" PITCH • ESCA SERIES

14
Gbps



ESCA
Mates:
SEAM8, SEAF8

ESCA	NO. OF PINS PER ROW	NO. OF ROWS	CABLE LENGTH	END 1	END 2
------	---------------------	-------------	--------------	-------	-------

-20, -30

-08
= Eight Rows

-10
= Ten Rows

-"XX.X"
= Overall Length in Inches
(50.8 mm) 02.0"
minimum

-1
= SEAM8 without Screw Down

-2
= SEAM8 with Screw Down

-3
= SEAF8 without Screw Down

-4
= SEAF8 with Screw Down

SPECIFICATIONS

Cable:
34 AWG micro ribbon coax cable
Signal Routing:
50 Ω Single-Ended
Plating:
Au over 50 μ" (1.27 μm) Ni
Operating Temp Range:
-25 °C to +105 °C

NO. PINS PER ROW	A	B	C
-20	(23.65) .931	(28.73) 1.131	(35.20) 1.386
-30	(31.65) 1.246	(36.73) 1.446	(43.20) 1.701

SIGNAL MAPPING

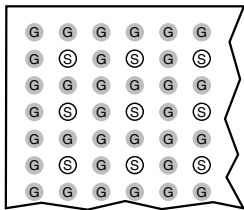

For complete signal mapping, see www.samtec.com?ESCA. For other alternative mapping options, contact hdr@samtec.com.

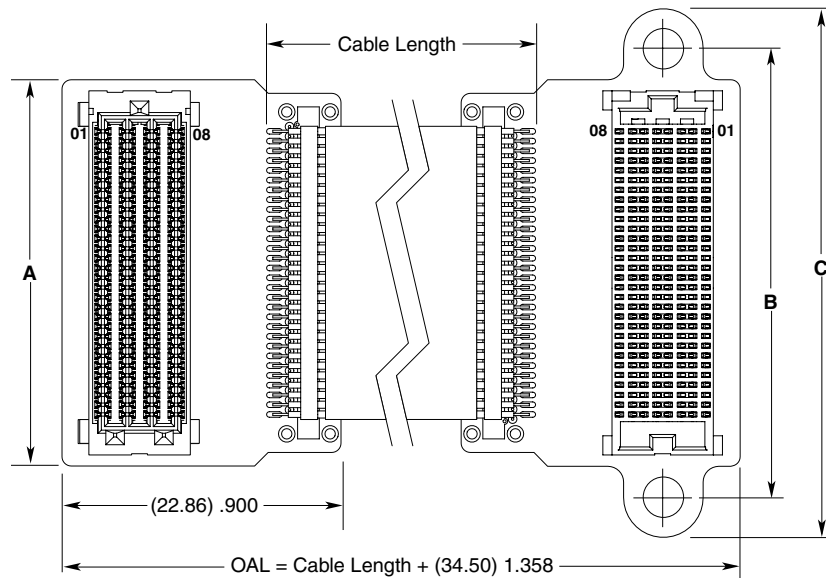

Notes:
Cable lengths longer than 40.00" (1 meter) are not supported with S.I. test data.

Design your full cable assembly with Samtec's High-Speed Cable Builder at www.samtec.com/cablebuilder

Some lengths, styles and options are non-standard, non-returnable.

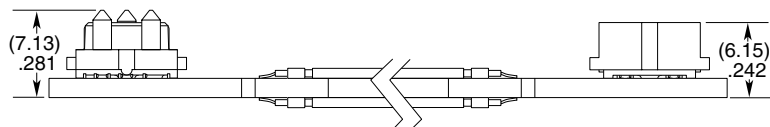

ESCA-30-08-XX.XX-1-4 SHOWN

PCI EXPRESS® JUMPERS

(1.00 mm) .0394" PITCH • PCIEC SERIES

14
Gbps

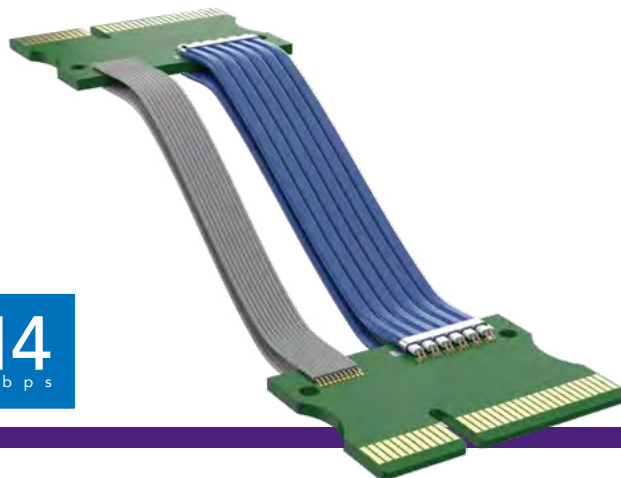

PCIEC

Mates:
PCIE, PCIE-LP

SPECIFICATIONS

Cable:
Eye Speed® 30 AWG twinax or
Eye Speed® 32 AWG twinax;
30 AWG insulated ribbon

Operating Temp:
-25 °C to +105 °C

Contact:
Phosphor Bronze

Plating:
Au or Sn over 50 μ" Ni

Performance:
Supports PCIe® Gen 2 & 3

Bend Radius:
(3.18 mm) .125"

-EM Connector:
Black Nylon

Card Insertion Depth:
(8.00 mm) .315"

PCIEC	NO. OF POSITIONS	WIRE LENGTH	END NO. 1	END NO. 2	CABLE OPTION	IMPEDANCE
	-036 (x1), -064 (x4), -098 (x8), -164 (x16)	-"XXXX" = Wire Length in millimeters 0050 mm minimum	-EC = Edge Card	-EC = PCIe® Edge Card -EM = PCIe® Edge Mount Connector	Specify CABLE OPTION from chart	Leave blank for 100 Ω -85 = 85 Ω

CABLE OPTION	IMPEDANCE	
	85 Ω	100 Ω
BLANK	32 AWG TAPED SHIELD	NOT AVAILABLE*
-C (No Power Lines)	NOT TOOLED*	30 AWG TAPED SHIELD
-CP (With Power Lines)	NOT TOOLED*	30 AWG TAPED SHIELD
-P (With Power Lines)	32 AWG TAPED SHIELD	NOT AVAILABLE*

* Contact hdr@samtec.com for information

APPLICATIONS

Loop back Extender (From one PCIe® slot to another PCIe® slot)
Ser-Des Physical Extender (From one PCIe® slot to another PCIe® Ser-Des)
Physical Extender for easy troubleshooting of PCIe® card debug and analysis
(PCIe® slot to Emulator or Analyzer)

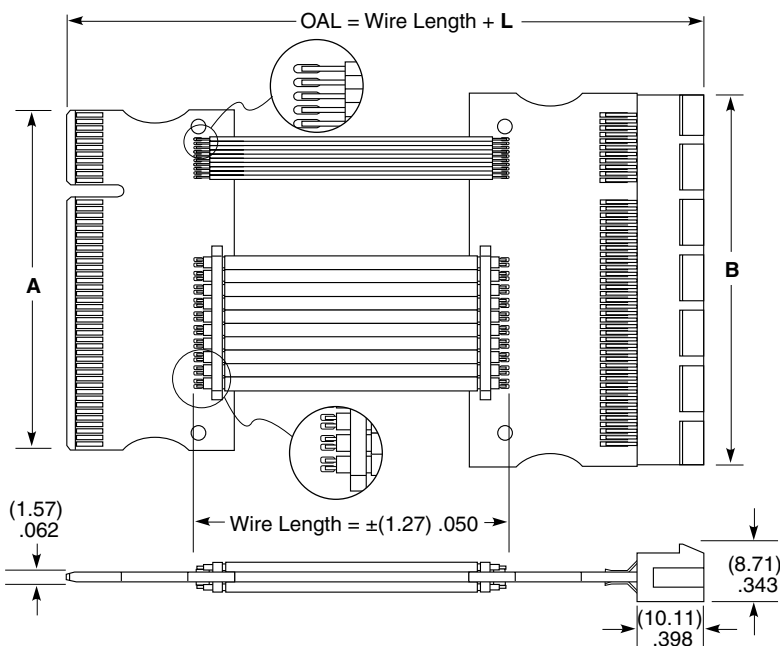

END TO END	L
-EC to -EC	(39.6) 1.56
-EC to -EM	(49.6) 1.95

NO. OF POSITIONS	A	B
-036 (x1)	(20.30) .800	(25.40) 1.00
-064 (x4)	(34.30) 1.35	(39.40) 1.55
-098 (x8)	(51.30) 2.02	(56.40) 2.22
-164 (x16)	(84.30) 3.32	(89.40) 3.52

Notes:
Cable lengths longer than
40.00" (1 meter) are not
supported with S.I. test data.

Design your full cable
assembly with Samtec's
High-Speed Cable Builder at
www.samtec.com/cablebuilder

PCI-SIG®, PCI Express® and
the PCIe® design marks are
registered trademarks and/or
service marks of PCI-SIG

This Series is non-standard,
non-returnable.

HIGH-SPEED COST EFFECTIVE COAX CABLE

(0.80 mm) .0315" PITCH • FCF8/FCS8 SERIES



FCF8

Mates:
FCS8



SPECIFICATIONS

Cable:
38 AWG coax
Overmold:
Nylon
Terminal Material:
Phosphor Bronze
Contact Plating:
Au or Sn over
50 μ " (1.27 μ m) Ni
Operating Temp Range:
-25 °C to +105 °C
Current Rating:
1.8 A per pin
(1 pin powered)

Notes:
Design your full cable assembly with Samtec's High-Speed Cable Builder at www.samtec.com/cablebuilder

Cable lengths longer than 40.00" (1 meter) are not supported with S.I. test data.

Some lengths, styles and options are non-standard, non-returnable.

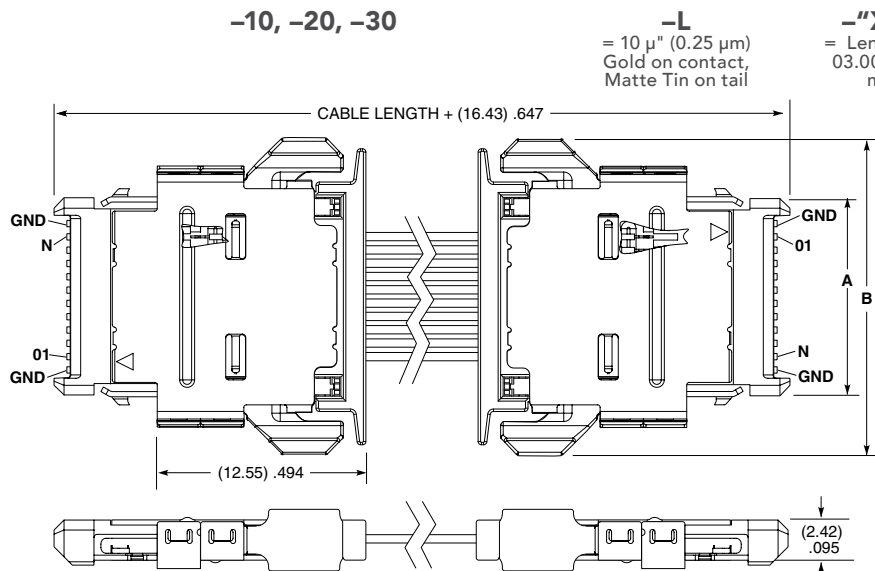

NO. OF POSITIONS	A	B
-10	(11.85) .467	(19.00) .748
-20	(19.85) .781	(27.00) 1.063
-30	(27.85) 1.096	(35.00) 1.378

ALSO AVAILABLE

Other sizes and lengths (MOQ Required)

FCS8

Mates:
FCF8



SPECIFICATIONS

Insulator Material:
Black LCP
Contact Material:
BeCu
Contact Plating:
Au or Sn over
50 μ " (1.27 μ m) Ni
Shield:
Nickel Plated Phosphor Bronze
Operating Temp Range:
-55 °C to +125 °C
Current Rating:
1.8 A per pin
(1 pin powered)

PROCESSING

Lead-Free Solderable:

Yes

SMT Lead Coplanarity:

(0.15 mm) .006" max*
*(.004" stencil solution may be available; contact IPG@samtec.com)

Note:

Some sizes, styles and options are non-standard, non-returnable.

-10, -20, -30

-L
= 10 μ " (0.25 μ m)
Gold on contact,
Matte Tin on tail

-TR
= Tape & Reel

-FR
= Full Reel
Tape & Reel
(must order max. quantity per reel; contact Samtec for contact quantity breaks)

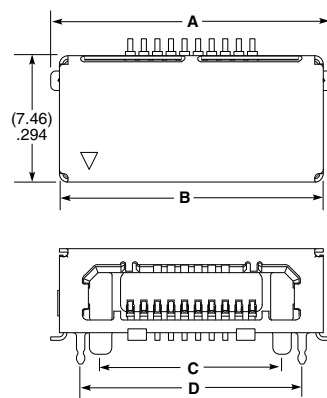

NO. OF POSITIONS	A	B	C	D
-10	(16.59) .653	(15.56) .613	(10.70) .421	(13.06) .514
-20	(24.59) .968	(23.56) .928	(18.70) .736	(21.06) .829
-30	(32.59) 1.283	(31.56) 1.243	(26.70) 1.051	(29.06) 1.144

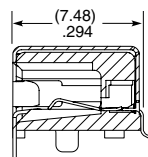

HIGH-DENSITY HIGH-SPEED I/O SYSTEM

(0.635 mm) .025" PITCH • HDLSP/HDI6/HDC SERIES



HDLSP

Mates:
HDI6

SERIES	NO. OF POSITIONS	LENGTH
--------	------------------	--------

SPECIFICATIONS

Cable:
32 AWG low skew pair cable
Insulator Material:
LCP
Terminal Material:
Phosphor Bronze
Jacket Material:
PVC
Insulator:
Dielectric
Conductors:
Copper
Braid:
Tinned Copper
Covers:
Diecast Zinc Alloy
Current Rating:
1.5 A per pin
(4 adjacent pins powered)

HDLSP
= High-density Low Skew Pair Cable

-035
(Per Row)
= 12 Pairs per side

-"XXXX"
= Length in millimeters
-1000, -2000
(Standard lengths)

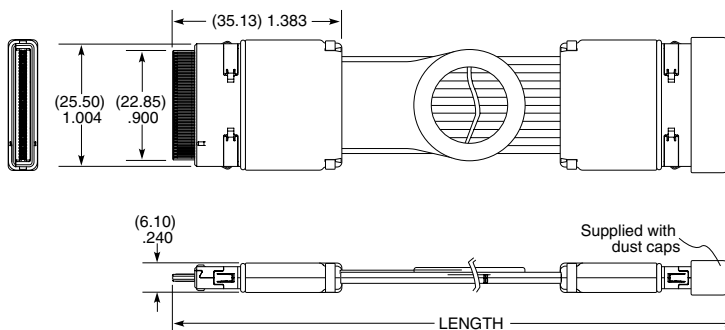

Note:
Some lengths, styles and options are non-standard, non-returnable.

HDI6

Mates:
HDLSP

HDI6	NO. OF POSITIONS	01	RA	"X"R	SERIES	NO. OF POSITIONS	01
------	------------------	----	----	------	--------	------------------	----

SPECIFICATIONS

Insulator Material:
Black LCP
Terminal Material:
Phosphor Bronze
Plating:
Au or Sn over 50 μm (1.27 μm) Ni
Current Rating:
1.5 A per pin
(4 adjacent pins powered)
Operating Temp Range:
-25 °C to +105 °C
Voltage Rating:
150 VAC

-035
(Per Row)

-TR
= Tape & Reel

HDC
= Cage

-035
= Number of positions

-FR
= Full Reel Tape & Reel (must order max. quantity per reel; contact Samtec for quantity breaks)

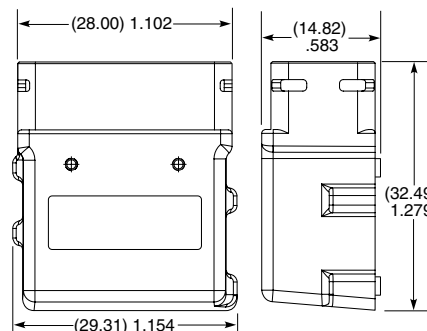
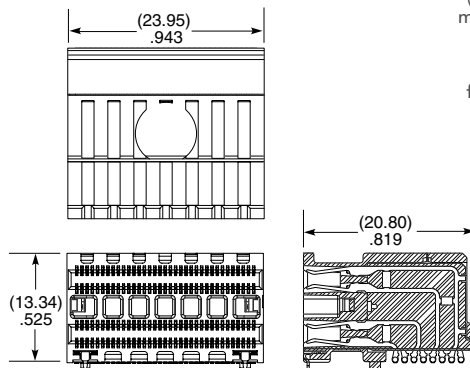

Notes:
For HT3.1 see www.samtec.com/ht3 and specify part number ASP-149117-01

Some lengths, styles and options are non-standard, non-returnable.

RUGGED LATCHING HIGH-SPEED SYSTEM



(0.80 mm) .0315" PITCH • EPLSP/ERI8/ERC SERIES

EPLSP

Mates:
ERI8

SPECIFICATIONS

Cable:
32 AWG Low Skew Pair/
28 AWG Power
Bend Radius:
(25.40 mm) 1.00"
Signal Routing:
100 Ω Differential
Pinout Map:
1:1 Map Standard
(See web address below
for additional information)
Operating Temp Range:
-20 °C to +105 °C
Current Rating:
1.7 A per pin
(2 pins powered)

Note:
This Series is non-standard,
non-returnable.

SERIES	NO. OF POSITIONS	LENGTH
--------	------------------	--------

EPLSP
= Eye Speed® I/O Cable

-019
= 9 Pairs, 5 Power, 19 positions

-"XXXX"
= Length in millimeters
-1000, -2000, -3000
(Standard lengths)

-031
= 17 Pairs, 5 Power, 31 positions

NO. OF POSITIONS	A
-019	(23.85) .939
-031	(32.95) 1.30

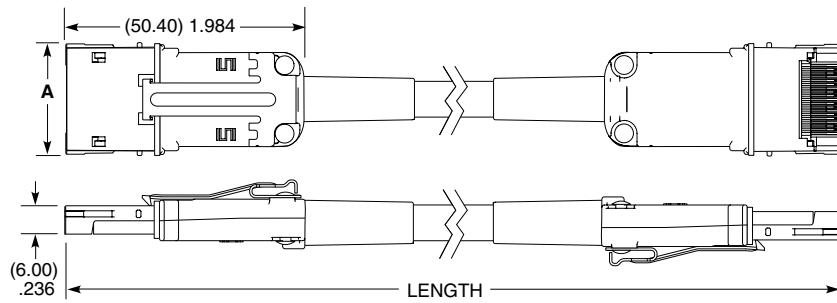

ERI8

Mates:
EPLSP

SPECIFICATIONS

Insulator Material:
Black LCP
Terminal Material:
BeCu
Plating:
Au or Sn over
50 μ" (1.27 μm) Ni
Current Rating:
1.7 A per pin
(2 pins powered)
Voltage Rating:
225 VAC/320 VDC
Operating Temp Range:
-55 °C to +125 °C



PROCESSING

Lead-Free Solderable:
Yes
SMT Lead Coplanarity:
(0.10 mm) .004" max

Notes:
Active equalization
reference design for
Eye Speed® I/O system
see www.samtec.com?EPLSP

Some lengths, styles and
options are non-standard,
non-returnable.

ERI8	NO. OF POSITIONS	PLATING OPTION	D	RA	OTHER OPTION	SERIES	NO. OF POSITIONS	01	OPTION
------	------------------	----------------	---	----	--------------	--------	------------------	----	--------

-019
= 9 Pairs,
5 Power,
19 positions

-S
= 30 μ"
(0.76 μm)
Gold on
contact,
Matte Tin
on tail

-TR
= Tape
& Reel

-FR
= Full Reel
Tape &
Reel
(must
order
max.
quantity
per reel;
contact
Samtec
for
quantity
breaks)

ERC
= Cage

**-019,
-031**
= Number of
Positions

-01
= Without
Gasket

-02
= With
Gasket

NO. OF POSITIONS	A
-019	(19.08) .751
-031	(28.68) 1.13

NO. OF POSITIONS	A
-019	(30.55) 1.203
-031	(40.15) 1.58

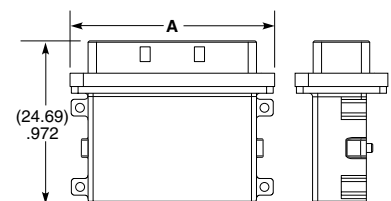
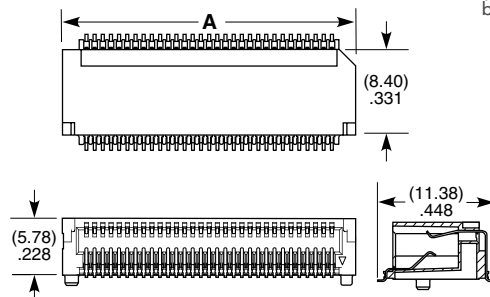

SFP & SFP+ CABLE & TRANSCEIVER

(0.80 mm) .0315" PITCH • SFPE/MECT SERIES

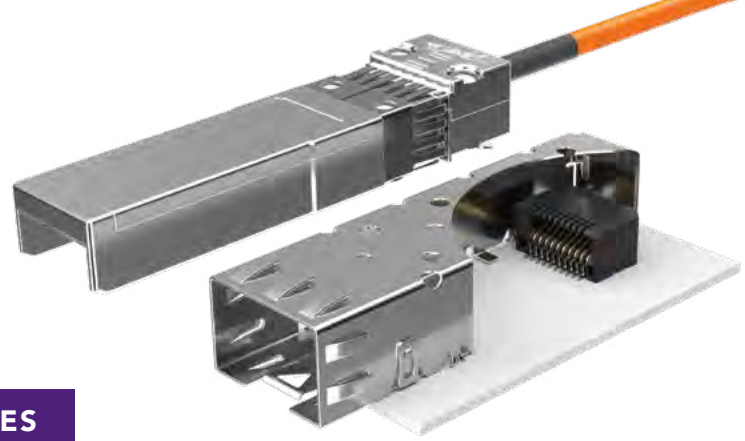

SFPE
Mates:
MECT, SFPC

SPECIFICATIONS

Impedance:
100 Ω
Signal Routing:
Differential

SFPE	NO. OF PAIRS	CABLE LENGTH	EQUALIZATION	WIRE GAUGE
	-010 = 2 Pairs	-XXXX = Length in millimeters -1000, -2000, -3000 (Standard lengths)	-NE = Non Equalized	-32 = 32 AWG

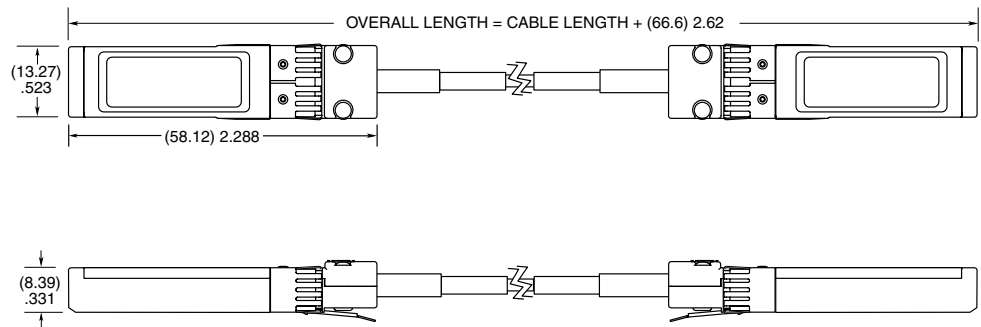

MECT
Mates:
SFP, SFP+, XFP or
XENPAK transceivers

SPECIFICATIONS

Insulator Material:
Black LCP
Contact Material:
Phosphor Bronze
Plating:
Sn or Au over
100 μ" (2.54 μm) Ni
Operating Temp Range:
-55 °C to +125 °C
Current Rating:
2 A per pin
(6 pins powered)
Voltage Rating:
265 VAC

MECT	1	POSITIONS PER ROW	CARD THICKNESS	PLATING OPTION	D	RA1	OTHER OPTION
		10, 15, 35	-01 = (1 mm) .039" thick board	-M = 15 μ" (0.38 μm) Gold on contact, Matte Tin on tail			-TR = Tape & Reel -FR = Full Reel Tape & Reel (must order max. quantity per reel; contact Samtec for quantity breaks)

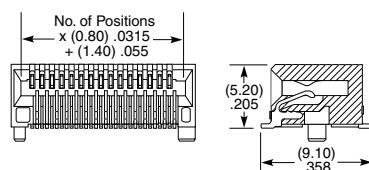
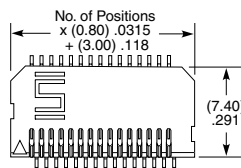

15 POSITIONS SHOWN

PROCESSING

Lead-Free Solderable:
Yes
SMT Lead Coplanarity:
(0.10 mm) .004" max

Note:
Some sizes, styles and
options are non-standard,
non-returnable.

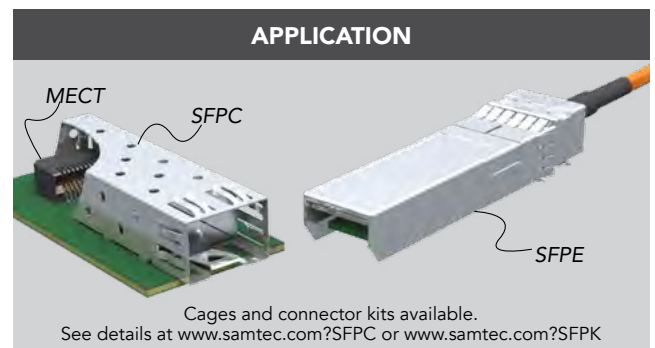

STANDARD & RUGGED USB 2.0

USB-A/USBR-A/USB-AM SERIES



SPECIFICATIONS

Insulator Material:

High Temperature Thermoplastic

Contact Material:

Phosphor Bronze

Plating:

Gold on Contacts, Nickel on Shell, Tin on Tails

Operating Temp Range:

-50 °C to +85 °C

Voltage Rating:

30 VAC

Cycles:

1500 (max tested)

Packaging:

Packaged and shipped in Bulk Packaging Trays; Trays suitable for automation available

Lead-Free Solderable:

-TH & -VU=Yes

(Wave Solder only)

TID Numbers (USB-A):

USB-A-D-X-X-TH (61001199)

USB-A-S-X-X-TH (61001180)

USB-A-S-X-X-SM2 (61001152)

TID Number (USB-AM):

USB-AM-S-X-X-SM (61001154)

SERIES	A	SHELL TYPE	PLATING	COLOR	TERMINATION
--------	---	------------	---------	-------	-------------

USB = Standard Connector		-S = Single	-F = Gold Flash on Mating Area, Tin on Tails	-B = Black (USB only)	-TH = Through-hole
USBR = Increased Retention Connector (Complies with Class 1, DIV II minimum withdrawal requirement of 15N.)		-D = Double (-TH option only)	-S = 30 μ" (0.76 μm) Gold on Mating Area, Tin on Tails	-W = White (USB only)	-SM2 = Surface Mount (USB only)
				-O = Orange (USBR only)	-VU = Upright, Through-hole

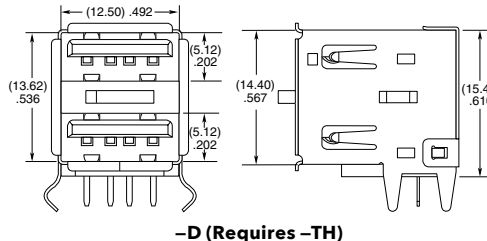
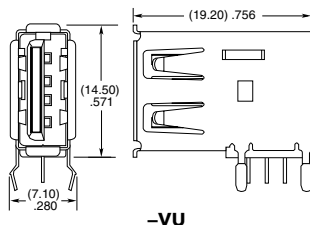
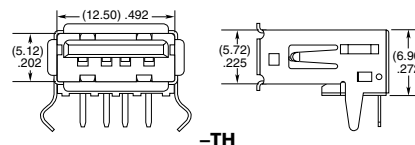
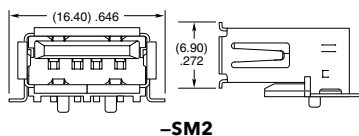

USB	TYPE	SHELL TYPE	PLATING	COLOR	TERMINATION
-----	------	------------	---------	-------	-------------

	-AM = A Type (Plug)	-S = Single	-F = Gold Flash on Mating Area, Tin on Tails	-B = Black	-TH = Through-hole
			-S = 30 μ" (0.76 μm) Gold on Mating Area, Tin on Tails	-W = White	-SM1 = Surface Mount

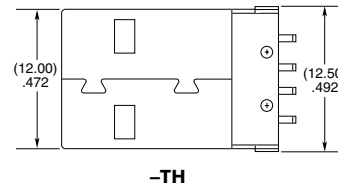
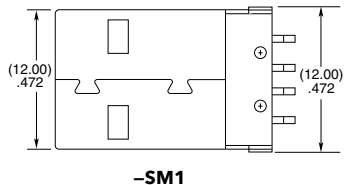
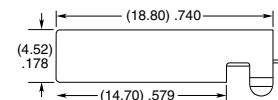
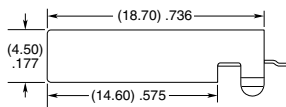

STANDARD & RUGGED USB 2.0

USB-B/USBR-B SERIES

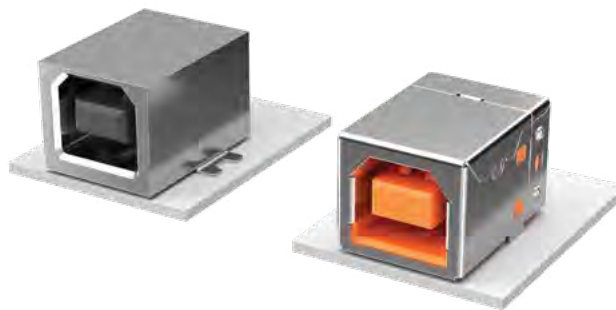

SPECIFICATIONS

Insulator Material:

High Temperature Thermoplastic

Contact Material:

Phosphor Bronze

Plating:

Gold on Contacts, Nickel on Shell, Tin on Tails

Operating Temp Range:

-50 °C to +85 °C

Voltage Rating:

30 VAC

Cycles:

1500 (maximum number of cycles tested)

Packaging:

Packaged and shipped in Bulk Packaging Trays; Trays suitable for automation are available upon request.

Lead-Free Solderable:

USB-SM=Yes

USB-TH= Yes

(Wave Solder only)

USBR=Yes (Wave Solder only)

TID Number:

USB-B-S-X-TH (61001155)

SERIES	B	S	PLATING	COLOR	TERMINATION	OTHER OPTION
USB = Standard Connector			-F = Gold Flash on Mating Area, Tin on Tails	-B = Black (USB only)	-TH = Through-hole	-TR = Tape and Reel (-SM only)
USBR = Increased Retention Connector (Complies with Class 1, DIV II minimum withdrawal requirement of 15N)			-S = 30 μ" (0.76 μm) Gold on Mating Area, Tin on Tails	-W = White (USB only)	-SM = Surface Mount (USB only)	-FR = Full Reel Tape & Reel (must order maximum quantity per reel; contact Samtec for quantity breaks) (-SM only)
				-O = Orange (USBR only)	-VT = Vertical Top Entry	

MATING / UNMATING FORCE (100 CYCLES)		
SERIES	MATING	UNMATING
USB	5.3 (23.59 N)	6.1 (27.15 N)
USBR	11.8 (52.51 N)	11.5 (51.18 N)

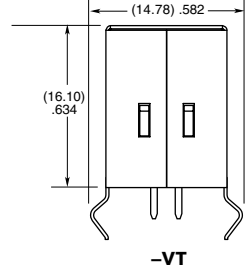
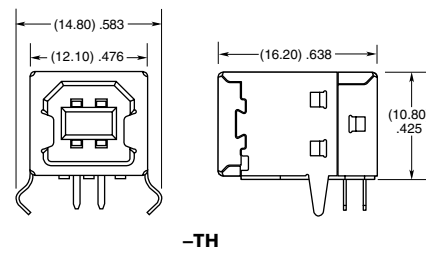
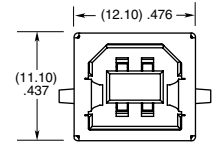
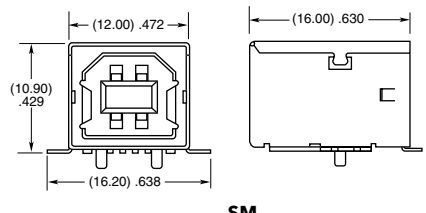

OPTICS

FUTURE PROOF • HIGH PERFORMANCE • PCI EXPRESS® • END OPTION FLEXIBILITY

129

FIREFLY™ MICRO FLYOVER SYSTEM™ (ECUO)

FIREFLY™



130

FIREFLY™ EXTENDED TEMPERATURE MICRO FLYOVER SYSTEM™ (ETUO)

FIREFLY™



131

PCI EXPRESS®-OVER-FIBER FIREFLY™ SYSTEM (PCUO)

PCI EXPRESS®

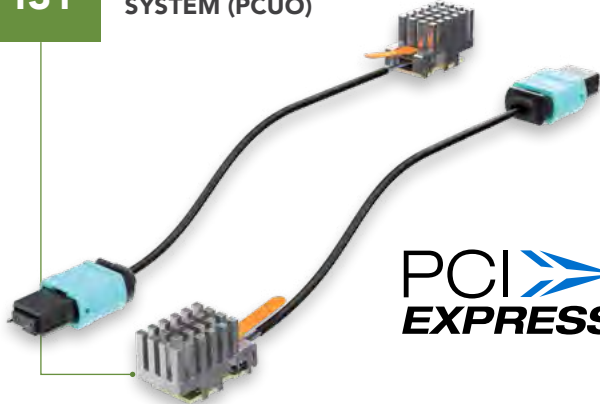

132

PCI EXPRESS®-OVER-FIBER FIREFLY™ ADAPTOR CARD (PCOA)

PCI EXPRESS®

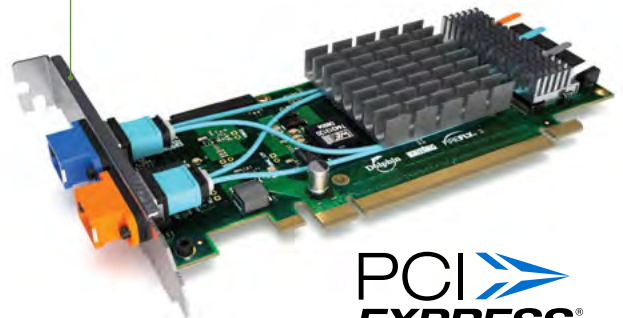

133

OPTICAL PATCH CABLE & ADAPTOR (FOPC, OPA)

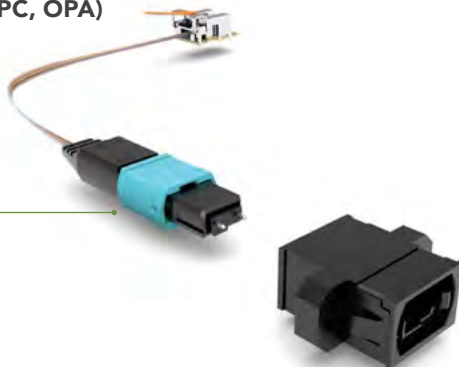

134

FIREFLY™ EVALUATION & DEVELOPMENT KITS



FIREFLY™ MICRO FLYOVER SYSTEM™



FEATURES & BENEFITS

- Data connection taken “off board” simplifies board layout
- Industry leading miniature footprint allows for higher density close to data source
- Performance up to 28 Gbps per lane with a path to 56 Gbps PAM4 via optical cable for greater reach
- Simple assembly process with easy insertion/removal and trace routing, no through-holes
- Interchangeability of copper and optical using the same two-piece surface mount connector
- PCI Express®-Over-Fiber (PCUO) supports PCIe® protocol for low latency, power savings and guaranteed transmission; 3.0 and 4.0 solutions
- -40 °C to +85 °C extended temperature system for military, aerospace and industrial applications
- Flexible end options include MTP®, MT, MXC®, U-SDI interface, MT38999, VITA 66.X and other common interfaces
- Variety of integral heat sinks for conduction and convection cooling



Micro two-piece connector system



PCI Express®-Over-Fiber Adaptor Card

PRODUCT ROADMAP

Advanced Optics

Samtec is focused on bringing to market 112 Gbps PAM4 solutions that are scalable, manufacturable and cost-efficient.

Extreme Environments

Sealed for salt fog, blowing sand and dust, jet fuel exposure, etc. for exposed Military applications

Immersion Cooling

Capable of immersion for liquid cooled systems.



PCI-SIG®, PCI Express® and the PCIe® design marks are registered trademarks and/or service marks of PCI-SIG.

samtec.com/FireFly

Unless otherwise approved in writing by Samtec, all parts and components are designed and built according to Samtec's specifications which are subject to change without notice.



OPTICAL MICRO FLYOVER SYSTEM™

ECUO	WIDTH	DATA RATE	CABLE LENGTH	0	HEAT SINK	1	FIBER TYPE	END 2 OPTIONS
	-B04 = 4 Tx + 4 Rx -T12 = 12 Tx -R12 = 12 Rx -Y12 = 12 Tx + 12 Rx -U12 = 12 Channel AOC (Unidirectional)	-14 = 14 Gbps per lane -16 = 16.1 Gbps per lane (N/A -B04) -25 = 25.7 Gbps per lane (-B04 only) -28 = 28.1 Gbps per lane (-B04 only)	-"XXX" = Overall Length in Centimeters		-1 = Flat -2 = Pin-fin (-14 & -16 only) -3 = Flat with groove -4 = PCIe® Pin-fin (-14 & -16 only) -5 = 1.75 cm tall Pin-fin (-B04 only)		-4 = Aqua loose tube with Boot -5 = Jacketed ribbon with boot -6 = Jacketed ribbon -7 = Black loose tube with boot -8 = Black loose tube	(Leave blank for -U12) -Y12 requires -2X end option 12 Fibers -01 = MTP® Male -02 = MTP® Female -07 = MXC® Internal Plug -0E = MPO Plus®, Male, bayonet 24 Fibers -21 = MTP® Male -22 = MTP® Female -27 = MXC® Internal Plug -2E = MPO Plus®, Male, bayonet

ECUO
Mates with:
UEC5, UCC8, OPA

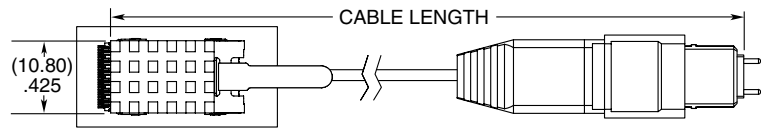

FEATURES

- Supports data center and HPC protocols, including: Ethernet, InfiniBand™, Fibre Channel
- Customizable optical connectors
- Integrated coupling capacitors
- Standard temperature range 0 °C to +70 °C
- Evaluation & Development boards available

Class 1 LASER PRODUCT
per IEC 60825-1 Ed. 3 (2014)

TOOLING

Insertion Tool: CAT-IN-ECUO-02

Notes:
MTP® is a registered trademark of US Conec Ltd.

All FireFly™ designs, specifications and components are preliminary and subject to change without notice.

Some lengths, styles and options are non-standard, non-returnable.

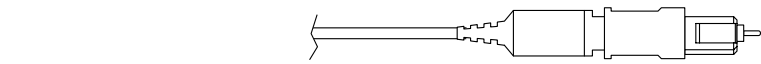

-01 (MTP® MALE SHOWN)

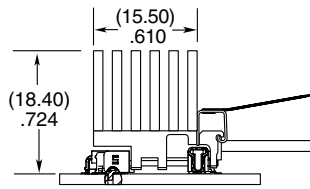

-2 PIN-FIN HEAT SINK



-07 (MXC® INTERNAL PLUG SHOWN)

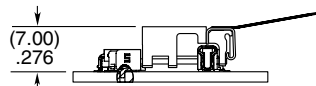

-1 FLAT HEAT SINK

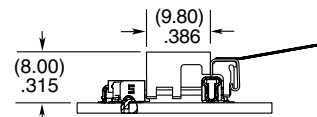

-3 FLAT WITH GROOVE HEAT SINK (MULTI-ROW CONFIGURATION)

View complete specifications at: samtec.com?ECUO

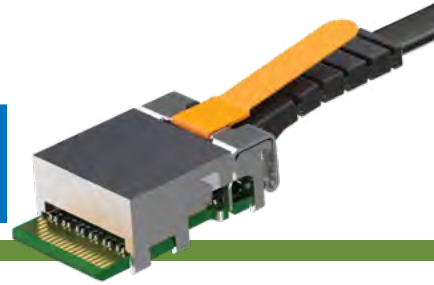

EXTENDED TEMP OPTICAL MICRO FLYOVER SYSTEM™

ETUO	WIDTH	DATA RATE	CABLE LENGTH	0	HEAT SINK	1	FIBER TYPE	END 2 OPTIONS
	-B04 = 4 Tx + 4 Rx -T12 = 12 Tx -R12 = 12 Rx -Y12 = 12 Tx + 12 Rx -U12 = 12 Channel AOC (Unidirectional)	-10 = 10.3125 Gbps -25 = 25.7 Gbps (-B04 only)	-"XXX" = Overall Length in Centimeters		-1 = Flat -2 = Pin-fin -3 = Flat with groove -4 = PCIe® Pin-fin (-10 only) -5 = 1.75 cm tall Pin-fin (-B04 only)		-5 = Jacketed ribbon with Boot -6 = Jacketed ribbon -7 = Black loose tube with boot -8 = Black loose tube	(Leave blank for -U12) -Y12 requires -2X end option 12 Fibers -01 = MTP® Male -02 = MTP® Female -07 = MXC® Internal Plug -0A = VITA 66.X Ready -0C = MT38999 Male -0E = MPO Plus®, Male, bayonet 24 Fibers -21 = MTP® Male -22 = MTP® Female -27 = MXC® Internal Plug -2A = VITA 66.X Ready -2C = MT38999 Male -2E = MPO Plus®, Male, bayonet

ETUO
Mates with:
UEC5, UCC8,
OPA

FEATURES

- Optimized for SWaP
- Extended temperature range from -40 °C to +85 °C
- Demonstrated error free transmission during applied external vibrations and shock test, to methods specified in MIL-STD-810G
- Micro rugged board level connector system with positive latching, weld tabs and loading guides for secure connection
- Pigtailed cable for maximum link budget
- Customizable optical connectors
- Integrated coupling capacitors
- Integral heat sink provides optimal cooling for thermal operating conditions
- Evaluation and Development boards available

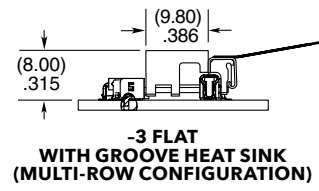
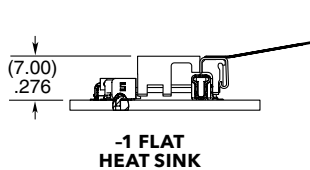
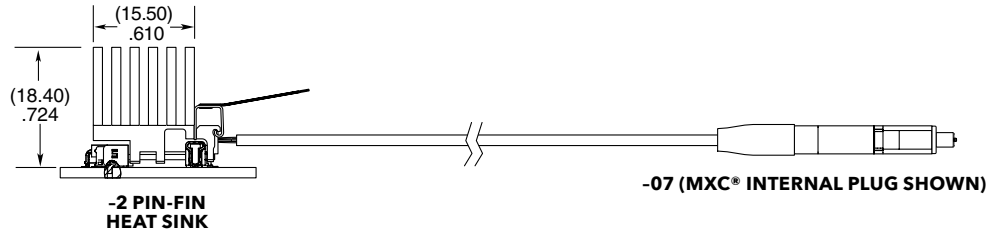

Class 1 LASER PRODUCT
per IEC 60825-1 Ed. 3 (2014)

View complete specifications at: samtec.com?ETUO

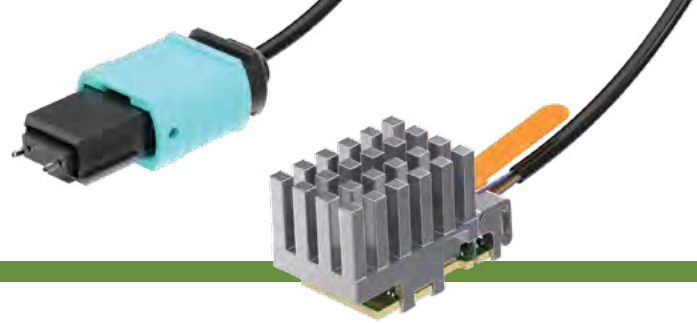

PCIe®-OVER-FIBER FLYOVER®

PCUO	WIDTH	SPEED	CABLE LENGTH	0	HEAT SINK	1	FIBER TYPE	END 2 OPTIONS
	-04 = x4 Lanes -08 = x8 Lanes	-G3 = Gen 3 -G4 = Gen 4	-"XXX" = Overall Length in Centimeters		-1 = Flat -4 = PCIe® Pin-fin		-7 = Black loose tube with boot -8 = Black loose tube	(-08 width requires -2X end option) -01/-21 = MTP® Male -02/-22 = MTP® Female -0A/-2A = VITA 66.X Ready -0C/-2C = MT38999 Male

PCUO
Mates with:
UEC5, UCC8,
OPA

FEATURES

- PCIe® 4.0 x4, scalable to x8 and x16 widths
- Duplex auxiliary signals allow both transparent and non-transparent bridging
- High-performance signal quality with BER better than 1E-12
- Enables links up to 100 m
- Allows nontraditional FPGA/ASIC end points
- Standard temperature range 0 °C to +70 °C

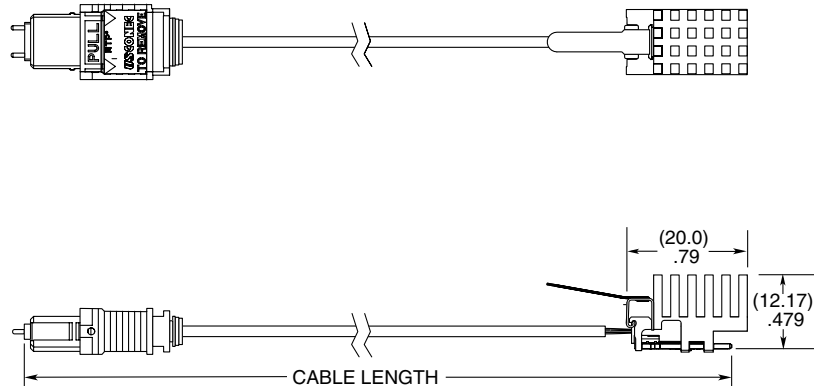

PCUO-04-G3-XXX-0-4-1-8 SHOWN

Class 1 LASER PRODUCT
per IEC 60825-1 Ed. 3 (2014)

View complete specifications at: samtec.com?PCUO



PCI EXPRESS
4.0 SOLUTIONS



PCIe®-OVER-FIBER ADAPTOR CARD

PCOA

SPEED

WIDTH

CONFIGURATION

- G3**
= Gen 3
- G4**
= Gen 4

- S4**
= Single x4
- D4**
= Dual x4
- Q4**
= Quad x4
- S8**
= Single x8
- D8**
= Dual x8
- 16**
= Single x16

-0A
= Transparent Bridge Host
(For non-transparent bridging support, contact Samtec)

FEATURES

- Uses PCUO FireFly™ optical cable for clear signal transmissions with increased reach and cost optimization
- PCIe® x16 edge card connector
- Scalable configurations for cost optimized performance
- Transparent or non-transparent bridging for system flexibility and multi-processor support
- Reconfigurable host or target operation
- Ideal for high-performance and applications requiring robust data transmission

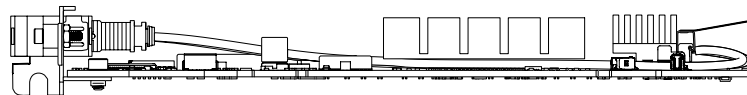
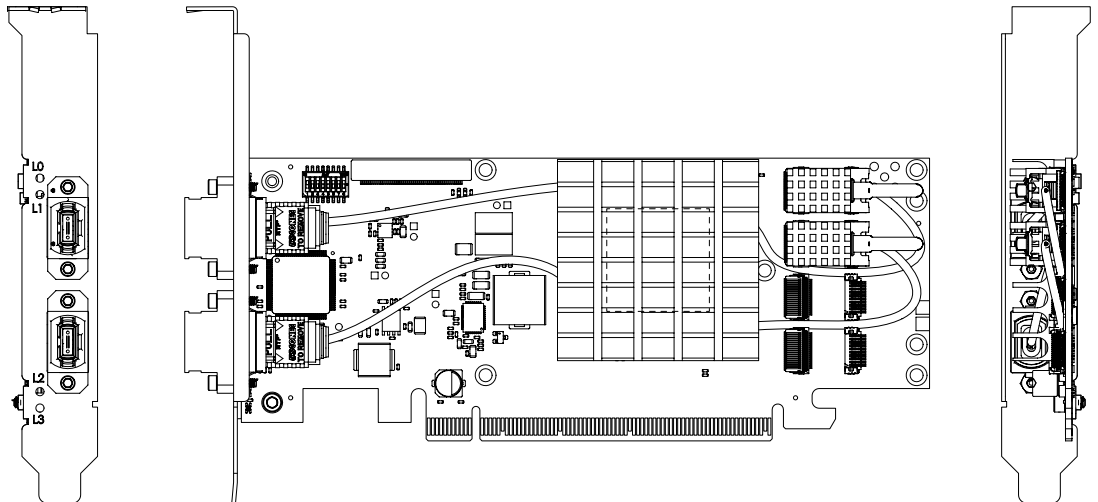

PCOA-G3-D4-0A SHOWN

Class 1 LASER PRODUCT
per IEC 60825-1 Ed. 3 (2014)
Gen 3 only (Gen 4 in testing)

Notes:
Some lengths, styles and options are non-standard, non-returnable.
PCI-SIG®, PCI Express® and the PCIe® design marks are registered trademarks and/or service marks of PCI-SIG.

View complete specifications at: samtec.com?PCOA

OPTICAL PATCH CABLE AND ADAPTOR

FOPC	END 1	END 2	CABLE LENGTH	FIBERS	CONSTRUCTION
	-01 = MTP Male	-01 = MTP Male	-003 = 3 Meters	-12, -24	-01 = 3 mm Round Jacket
	-02 = MTP Female	-02 = MTP Female	-010 = 10 Meters		
			-100 = 100 Meters (Other lengths available as custom parts)		

OVERALL LENGTH = CABLE LENGTH ±5%

-01-01-XXX-12-01

-02-02-XXX-24-01

12 FIBER

24 FIBER

SPECIFICATIONS

Compliant Specifications:
TIA-604-5-D (FOCIS 5)
TIA-568-C.3
IEC-61754-7-1

View complete specifications at: samtec.com?FOPC

OPA	PORTS	KEY	FLANGE
	-S = Single	-1 = Opposed	-F = Full
	-D = Double	-2 = Aligned	

-S

-D

-1

-2

SPECIFICATIONS

Compliant Specifications:
TIA-604-5-D (FOCIS 5)
IEC-61754-7

Recommended Panel Thickness:
(1.75 mm) .069"
(The OPA can be installed with any panel thickness but mounting hardware is needed for any thickness that is not (1.75 mm) .069". Contact the Optics Group at FireFly@samtec.com for questions about panel thickness and mounting hardware.)

View complete specifications at: samtec.com?OPA

Notes:
Some lengths, styles and options are non-standard, non-returnable



EVALUATION & DEVELOPMENT KITS

From concept and prototype to development and production, Samtec-designed and Partner-designed kits and boards featuring FireFly™ Micro Flyover System™ simplify design and reduce time to market. For more information, please visit samtec.com/kits or contact KitsAndBoards@samtec.com.

28 Gbps FireFly™ Evaluation Kit

Samtec's 28 Gbps FireFly™ Evaluation Kit offers an easy-to-use platform for testing and real-time evaluation of the FireFly™ Micro Flyover System™. The kit supports copper or optical FireFly™ in x4 or x12 configurations. (Samtec P/N: REF-209623-01)

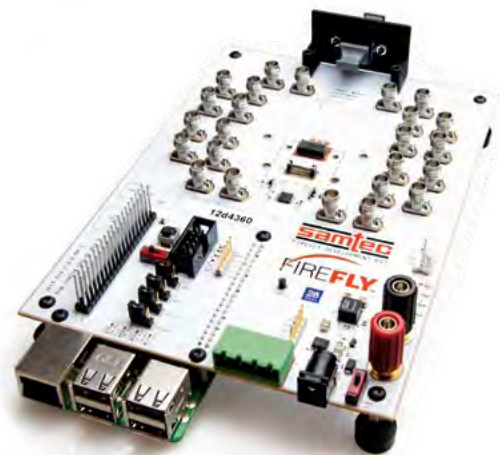

14 Gbps FireFly™ FMC Development Kit

Samtec's 14 Gbps FireFly™ FMC Development Kit is VITA 57.1 electrically compliant and provides up to 140 Gbps full-duplex bandwidth over 10 channels from an FPGA to an industry-standard multi-mode fiber optic cable. (Samtec P/N: REF-193429-01)



25/28 Gbps FireFly™ FMC+ Development Kit

Samtec's 25/28 Gbps FireFly™ FMC+ Module is VITA 57.4 electrically compliant and provides up to 400/448 Gbps full-duplex bandwidth over 16 channels from an FPGA to an industry-standard multi-mode fiber optic cable. (Samtec P/N: REF-200772-XXX-XX-01)



25 Gbps FireFly™ FMC+ Development Kit (In development)

Samtec's 25 Gbps FireFly™ FMC+ Module is VITA 57.4 electrically compliant and provides up to 300 Gbps full-duplex bandwidth over 12 channels from an FPGA to an industry-standard multi-mode fiber optic cable.

ECUE Flyover® SI Evaluation Kit

Samtec's ECUE Evaluation Kit routes eight high-speed differential pairs via UEC5-2/UCC8 series mating connectors, user-selected twinax cable lengths and 2.4 mm RF connectors. (Samtec P/N: REF-201830-XX)



RF SOLUTIONS

50 Ω & 75 Ω • PRECISION • 12G-SDI • NON-MAGNETIC • ORIGINAL SOLUTIONS

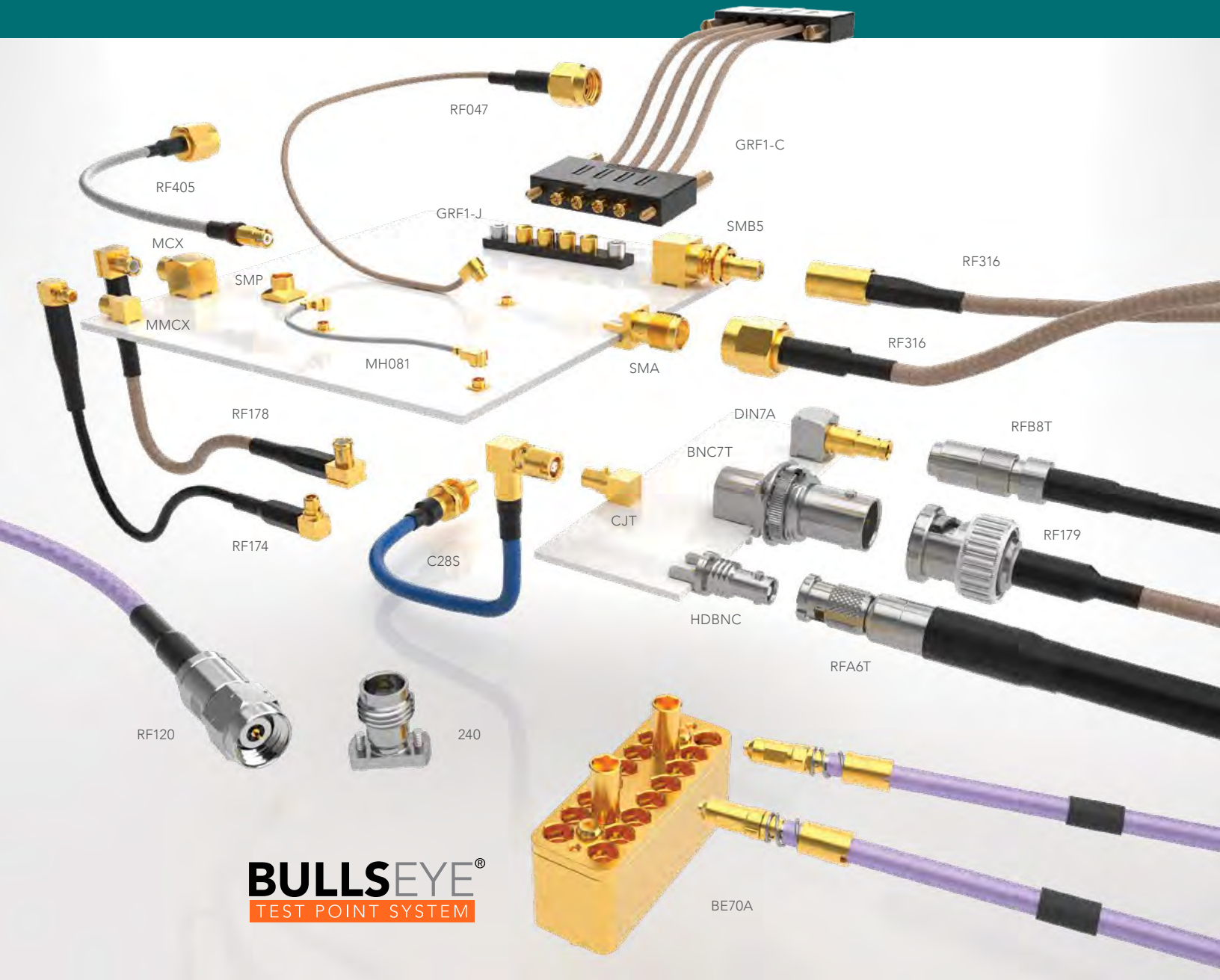

BULLSEYE[®]
TEST POINT SYSTEM

136-170

RF SOLUTIONS

50 Ω High-Frequency Precision RF (18 GHz to 110 GHz)	138-151
Bulls Eye [®] Test Assemblies (70 GHz).....	152-154
Ultra-Small Form Factor Waveguide Technology	155
50 Ω & 75 Ω Solutions (3 GHz to 12 GHz).....	156-168
Original RF Solutions.....	169
Custom RF Solutions.....	170

COMPLETE RF INTERCONNECT SOLUTIONS

50 Ω & 75 Ω • PRECISION • 12G-SDI • NON-MAGNETIC • ORIGINAL SOLUTIONS

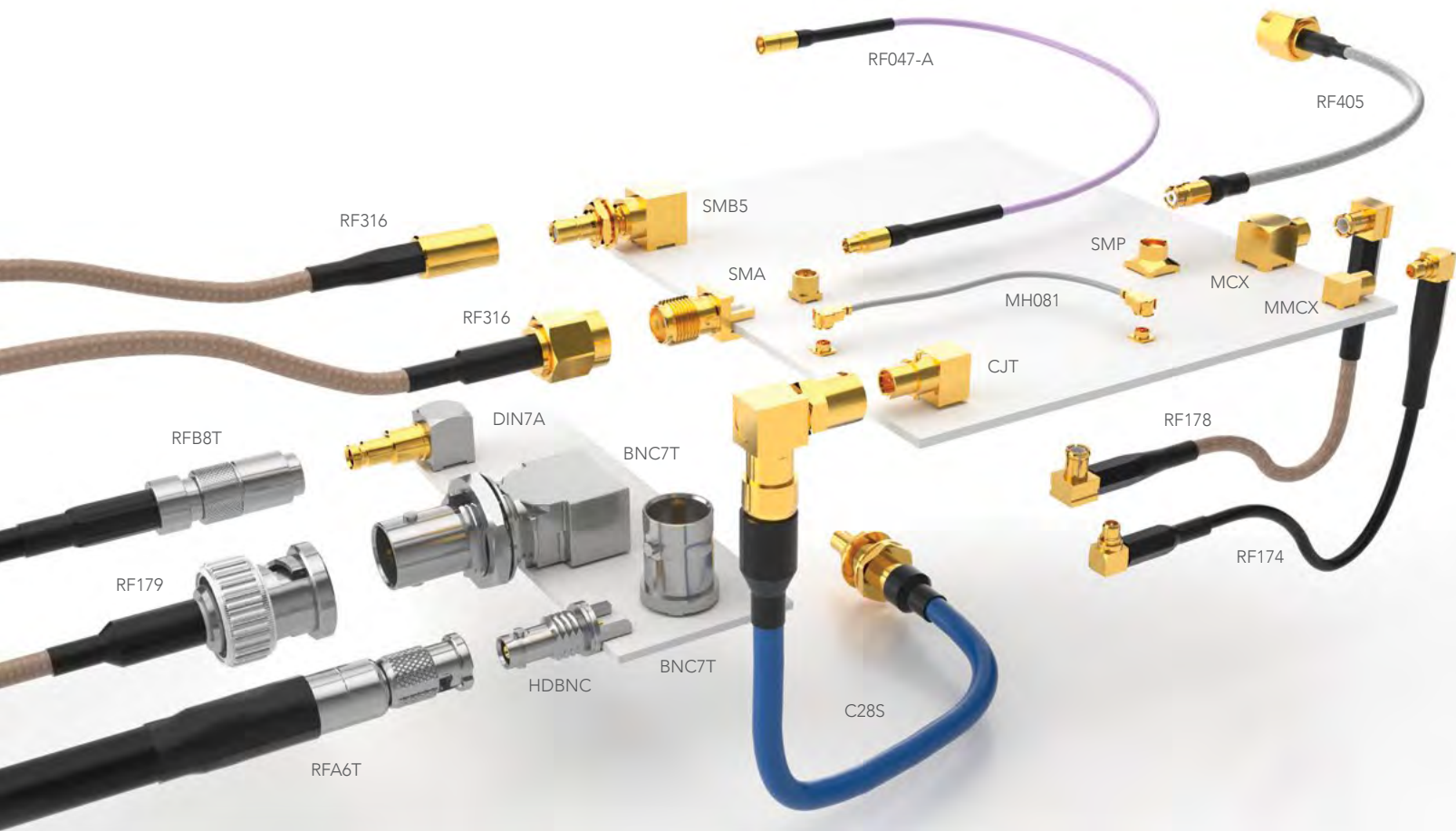

FULL LINE RF CABLE ASSEMBLIES & CONNECTORS

As a manufacturer of a broad line of electronic interconnects, Samtec offers full RF solution capabilities. In addition to high-frequency precision RF and high-performance test systems, Samtec's full line includes:

- Micro High-Frequency U.FL and W.FL
- 50 Ω and 75 Ω cable assemblies, cable connectors and board level interconnects
- Ganged and high isolation cable systems
- 100 Ω shielded twisted pair cable assemblies
- Micro-mini interconnects
- Non-magnetic RF solutions
- High-frequency, precision (18 GHz to 110 GHz)

Samtec is the service leader in the industry with the resources and willingness to provide technical support for launch optimization, simulation and test & measurement. Visit [samtec.com/RF](https://www.samtec.com/RF) for additional information.

50 Ω RF CABLES & CONNECTORS

- High-frequency cables: semi-flexible, solid, foamed or air enhanced dielectric
- Variety of straight and right-angle jacks, plugs and bulkhead jacks
- Double-shielded RG 316 cable
- Micro high-frequency U.FL/W.FL assemblies
- Wide variety of industry standard cables with mix & match cable connectors
- Precision interconnects supporting frequencies from 18 to 110 GHz



Precision Interconnects

NON-MAGNETIC RF SOLUTIONS

- Truly non-magnetic RF solutions; 100% inspected for magnetic permeability
- Nearly all Samtec interconnects can be ordered as non-magnetic
- Supported by Samtec's quick-turn lead times and unmatched service
- Ideal for medical imaging, advanced driver assistance systems, hand held devices, etc.
- Contact RFGroup@samtec.com



75 Ω RF CABLES & CONNECTORS

- Wide variety of industry standard cables with mix & match cable connectors
- Low-Profile BNC with Pick & Place capability, optimized for high volume manufacturing
- RFB8T Series (with Belden 1855A cable)
- Wide variety of terminations: BNC, HD-BNC™, DIN 1.0/2.3, SMB
- Straight and right-angle, die cast options
- 12G-SDI optimized 75 Ω interconnects

HD-BNC™ is a trademark of Amphenol.



Low-Profile BNC with Pick & Place Capability

12G-SDI BROADCAST VIDEO SOLUTIONS

- Samtec has the largest variety of 12G-SDI optimized products
- Analysis and launch optimization: RFGroup@samtec.com
- 75 Ω BNC, HD-BNC™ and DIN 1.0/2.3
- Right-angle, vertical, edge mount, low-profile and standard or tall through-hole
- For additional details, please visit: samtec.com/12gsdi



12G-SDI Broadcast Video

SAMTEC ORIGINAL SOLUTIONS

- High vibration and 75 Ω MMCX
- Ganged micro-miniature high-performance RF cable assemblies with rugged contacts
- Circular RF shielded twisted pair system
- IsoRate® cost-efficient high-performance isolated signal systems
- Machined U.FL to 500 cycles



Ganged Micro Scale Isolated Signal Systems

PRECISION RF

MICROWAVE / MILLIMETER WAVE CABLE ASSEMBLIES & INTERCONNECTS

The Samtec RF product line includes 18 to 110 GHz High-Frequency, Precision RF solutions for microwave and mmWave applications, including full cable assemblies, cable connectors and board level interconnects. Our focus is on delivering high-quality RF products that meet precision and performance expectations, blended with industry-leading system-level signal integrity expertise.

Vertical Integration

=

Full System Support

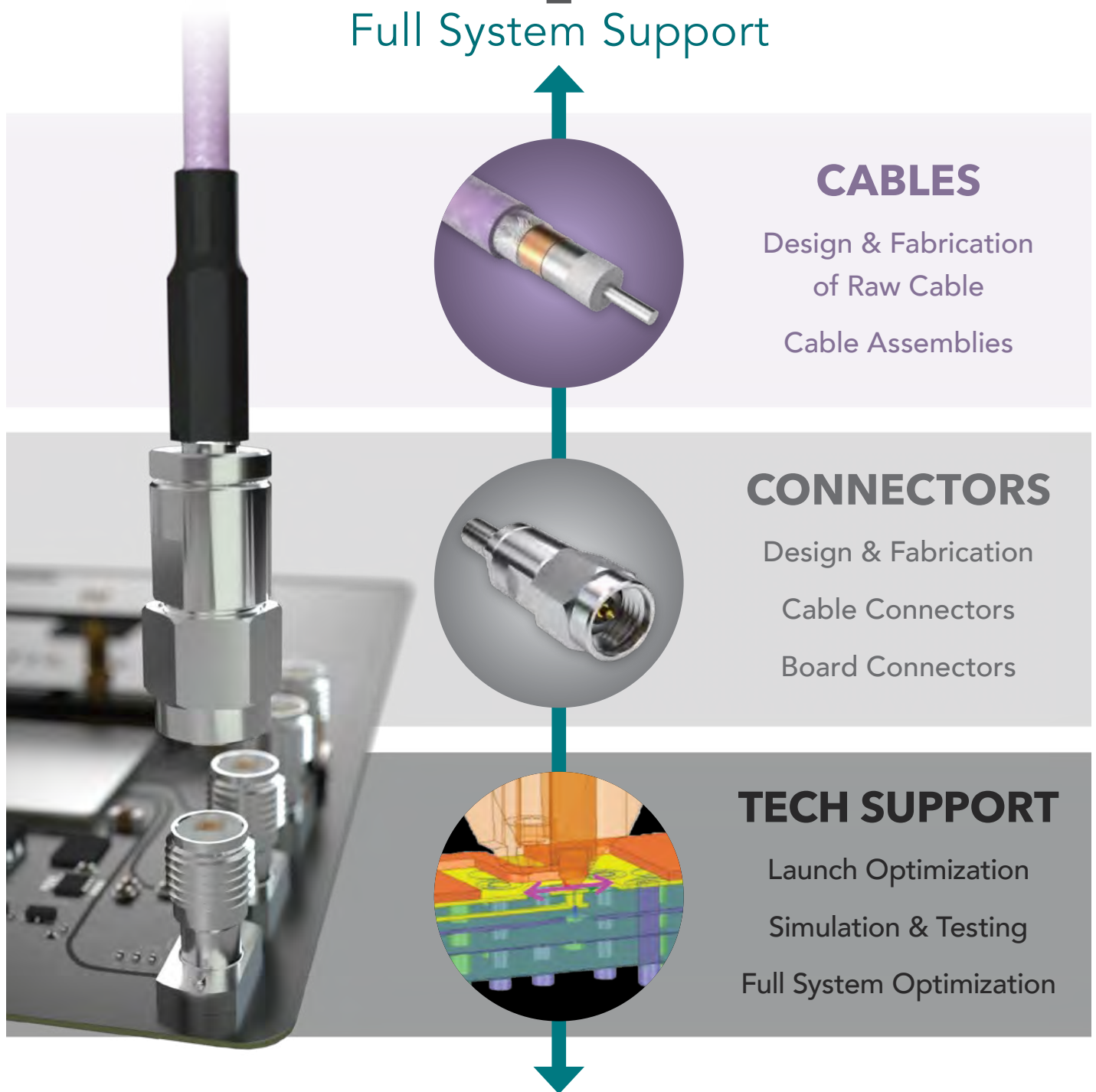

CABLES

Design & Fabrication
of Raw Cable

Cable Assemblies

CONNECTORS

Design & Fabrication

Cable Connectors

Board Connectors

TECH SUPPORT

Launch Optimization

Simulation & Testing

Full System Optimization

50 Ω μWAVE/mmWAVE CABLES



STANDARD OFF-THE-SHELF ASSEMBLIES

TYPE	MWC-2550-01	MWC-2350-01	MWC-2350CU-01	MWC-19550-FCU-01	RG 405 (.086")	RG 402 (.141")	.047 Low-Loss Flexible	.085 Low-Loss Flexible	.086 Low-Loss Flexible	.178 Low-Loss Flexible	.277 Low-Loss Flexible	
ELECTRICAL												
Max. Frequency (GHz)	40	35	50	45	20	20	65	50	65	27	18	
Max. Insertion Loss (dB/m)	1 GHz	0.79	0.72	0.68	0.43	0.72	0.40	1.21	0.69	0.65	0.27	0.17
	26 GHz	3.80 @ 20 GHz	3.71 @ 20 GHz	4.27	2.78	4.26 @ 20 GHz	2.30 @ 20 GHz	7.43	4.28	3.90	1.23 @ 18 GHz	0.79 @ 18 GHz
	40 GHz	–	–	5.59	3.66	–	–	9.68	5.59	5.06	–	–
	50 GHz	–	–	6.46	–	–	–	11.14	6.47	5.81	–	–
Propagation Delay (ns/m)	4.76	4.72	4.76	4.12	4.79	4.79	4.76	4.75	4.20	4.17	4.02	
Velocity of Propagation	70%			81%	70%	70%			80%		83%	
Capacitance (pF/m)	96.80	95.45	97.80	82.39	104.97	98.07	95.00	88.2	83.37	82.00		
CONSTRUCTION												
Center Conductor	Solid Silver Plated Copper											
Dielectric	FEP			Foam Fluoropolymer	PTFE		PFA	Solid PTFE	Foam Fluoropolymer	PTFE Tape		
Shield	1) Ag Plated Cu 2) Ag Plated Cu		1) Ag Plated Cu 2) Cu Tape 3) Ag Plated Cu	1) Ag Plated Cu 2) Ag Plated Cu	Tinned Cu		1) Ag Plated Cu 2) Ag Plated Cu	Spiral Strip Ag Plated Cu	1) Ag Plated Cu 2) Ag Plated Cu	1) Flat Ag Plated Cu 2) Al Polyester 3) Round Ag Plated Cu		
Jacket	FEP				–	–	FEP					
MECHANICAL												
Operating Temp	-40° C to 200° C		-65° C to 125° C	-65° C to 150° C	-40° C to 125° C	-40° C to 125° C	-65° C to 150° C	-55° C to 200° C	-65° C to 150° C	-55° C to 200° C		
Min. Bend Radius	9.00 mm	12.00 mm	6.00 mm	12.50 mm	6.00 mm	10.90 mm	5.00 mm	13.20 mm	8.90 mm	24.80 mm	38.10 mm	
Connector Options	SMA, SMP	3.50 mm	2.92 mm, 2.40 mm, SMPM	2.92 mm, 2.40 mm	SMA, SMP	SMA	1.35 mm, 1.85 mm, 2.40 mm, 2.92 mm, SMPM	2.92 mm, 2.40 mm	1.85 mm, 2.40 mm, 2.92 mm, SMPM	SMA, TNCA, N Type	SMA, TNCA, N Type	
PART NUMBER												
Series	RF25S	RF23S	RF23C	RF120	RF405	RF402	RF047-A	RF085	RF086	RF180	RF280	

*Shown at ~1/2 scale. ** Shown at 1/3 scale.

1.00 mm TO 110 GHz

1.00 mm Cable Connectors PRF10



CONNECTORS FOR INDUSTRY STANDARD CABLES	
PRF10-J-C-VP-047D-SS	.047, semi-rigid
PRF10-P-C-VP-047D-SS	.047, semi-rigid

J-C = Cable Jack
P-C = Cable Plug
VP = Plating (75 μ" Gold center contact, passivated outer contact)
SS = Straight, Solder Clamp

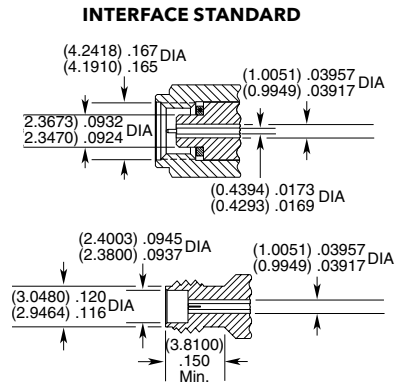

1.35 mm TO 90 GHz

1.35 mm Cable Assemblies RF047-A



SERIES	END 1 CONNECTOR	END 2 CONNECTOR	OVERALL LENGTH
--------	-----------------	-----------------	----------------

RF047-A
= (1.2 mm) .047" overshield DIA
29 AWG millimeter wave cable

-13SJ
= 1.35 mm Straight Jack

-13SP
= 1.35 mm Straight Plug

-"XXXX"
= Overall Length in millimeters

-0100 (0100 mm) 3.94" minimum

PRELIMINARY

ALSO AVAILABLE

1.85 mm, 2.40 mm, 2.92 mm, SMPM = RF047-A

VSWR

Contact Samtec

1.35 mm Cable Connectors PRF13



CONNECTORS FOR INDUSTRY STANDARD CABLES	
PRF13-P-C-VP-047A-SS	.047 Temp-Flex, low loss flexible, 29 AWG
PRF13-J-C-VP-047A-BS	.047 Temp-Flex, low loss flexible, 29 AWG

P-C = Cable Plug
J-C = Cable Jack
VP = Plating (75 μ" Gold center contact, passivated outer contact)
SS = Straight, Solder Clamp
BS = Bulkhead, Solder Clamp

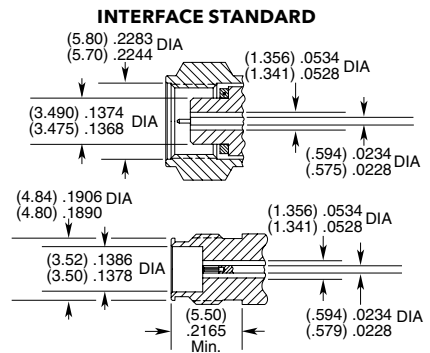

PRELIMINARY

1.35 mm Board Connectors 135

Cable Mates:
RF047-A



135	GENDER	TYPE	PLATING	ORIENTATION	TERMINATION	OPTION
-----	--------	------	---------	-------------	-------------	--------

-J
= Jack

-P
= PCB Mount

-VP
= Plating (75 μ" gold center contact, passivated outer contact)

-ST
= Straight

-CM
= Compression Mount

-1
= Without screws

-CMM
= Compression Mount Microstrip

-2
= With screws

PRELIMINARY

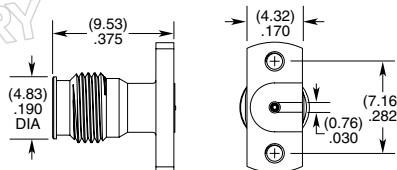

1.85 mm TO 65 GHz

1.85 mm Cable Assemblies

RF047-A, RF086



VSWR

RF047-A: 1.40 max.
RF086: 1.40 max.

SERIES	END 1 CONNECTOR	END 2 CONNECTOR	OVERALL LENGTH
RF047-A = (1.2 mm) .047" overshield DIA 29 AWG millimeter wave cable RF086 = (2.18 mm) .086" overshield DIA 23 AWG millimeter wave cable	-18SJ = 1.85 mm Straight Jack -18SP = 1.85 mm Straight Plug		-“XXXX” = Overall Length in millimeters -0100 (0100 mm) 3.94" minimum
ALSO AVAILABLE			
2.40 mm, SMPM, 2.92 mm = RF086			
1.35 mm, 2.40 mm, SMPM, 2.92 mm = RF047-A			

1.85 mm Cable Connectors

PRF18



CONNECTORS FOR INDUSTRY STANDARD CABLES	
PRF18-J-C-EP-047D-SS	.047, semi-rigid
PRF18-P-C-EP-047D-SS	.047, semi-rigid
PRF18-J-C-EP-086-SS	.086 Temp-Flex, low loss flexible
PRF18-P-C-EP-086-SS	.086 Temp-Flex, low loss flexible
PRF18-J-C-EE-405-SD	RG 405, .085, semi-rigid
PRF18-J-C-EP-085-BS	Harbour SS405, flexible alternative to RG 405
PRF18-P-C-EE-085-SD	Harbour SS405, flexible alternative to RG 405
PRF18-P-C-EP-085-SS	Harbour SS405, flexible alternative to RG 405
PRF18-P-C-EP-047A-SS	.047 Temp-Flex, low loss flexible, 29 AWG
PRF18-J-C-EP-047A-SS	.047 Temp-Flex, low loss flexible, 29 AWG

P-C = Cable Plug
 J-C = Cable Jack
 EE = Plating (50 μ" gold center contact, & outer contact)
 EP = Plating (50 μ" gold center contact, passivated outer contact)
 SS = Straight, Solder Clamp
 SD = Straight, Direct Solder
 BS = Bulkhead, Solder Clamp

INTERFACE STANDARD

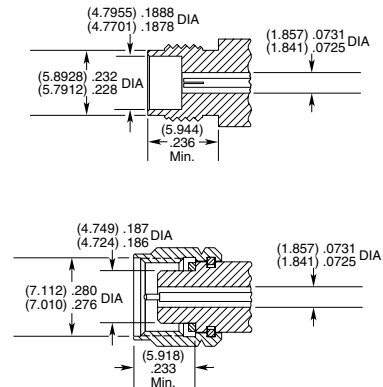

1.85 mm Board Connectors

185

Cable Mates:
RF047-A, RF086



185	GENDER	TYPE	PLATING	ORIENTATION	TERMINATION	OPTION
	-J = Jack	-P = PCB Mount	-EP = 50 μ" (1.27 μm) Gold center contact, Passivated outer contact	-ST = Straight	-CM = Compression Mount Stripline -CMM = Compression Mount Microstrip	-1 = Without Screws -2 = With Screws

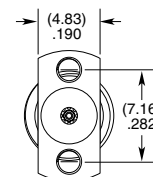
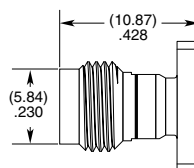

2.40 mm TO 50 GHz

2.40 mm Cable Assemblies

RF047-A, RF085, RF086, RF23C, RF120



VSWR

RF047-A: 1.35 max.
RF086: 1.40 max.
RF085: 1.40 max.
RF23C: 1.40 max.
RF120: 1.40 max.

SERIES

RF047-A (1.2 mm) .047" overshield DIA 29 AWG millimeter wave cable
RF086 = (2.18 mm) .086" overshield DIA 23 AWG millimeter wave cable
RF085 = (2.16 mm) .085" overshield DIA 24 AWG millimeter wave cable
RF23C = MWC-2350CU-01 millimeter wave cable with copper foil shield
RF120 = MWC-19550-FCU-01 19 AWG millimeter wave cable

END 1 CONNECTOR

-24SJ
= 2.40 mm Straight Jack
-24SP
= 2.40 mm Straight Plug

END 2 CONNECTOR

ALSO AVAILABLE

1.35 mm, 1.85 mm, 2.92 mm, SMPM = RF047-A
 1.85 mm, 2.92 mm, SMPM = RF086
 2.92 mm = RF085
 2.92 mm, SMPM = RF23C
 2.92 mm = RF120

OVERALL LENGTH

-“XXXX”
= Overall Length in millimeters
 -0100 (100 mm) 3.94" minimum (RF047-A, RF085, RF086, RF120)
 -0152 (0152 mm) 5.984" minimum (RF23C)

2.40 mm Cable Connectors

PRF24



CONNECTORS FOR INDUSTRY STANDARD CABLES

PRF24-J-C-EP-085-SS	Harbour SS405, flexible alternative to RG 405
PRF24-J-C-EP-405-BS	RG 405, .085, semi-rigid
PRF24-P-C-EE-085-SD	Harbour SS405, flexible alternative to RG 405
PRF24-P-C-EP-120A-SS	Semflex HP120, low loss flexible
PRF24-J-C-EP-160-SS	Semflex HP160, low loss flexible
PRF24-P-C-EP-160-SS	Semflex HP160, low loss flexible
PRF24-J-C-EP-140B-SS	IW 1401, low loss flexible
PRF24-P-C-EP-140B-SS	IW 1401, low loss flexible
PRF24-J-C-EP-150B-SS	IW 1501, low loss flexible
PRF24-P-C-EP-150-SS	Dynawave DF150, low loss flexible
PRR24-J-C-EP-086-SS	.086 Temp-flex, low loss flexible
PRF24-P-C-EP-086-SS	.086 Temp-flex, low loss flexible

P-C = Cable Plug
 J-C = Cable Jack
 EE = Plating (50 μ" gold center contact & outer contact)
 EP = Plating (50 μ" gold center contact, passivated outer contact)
 SS = Straight, Solder Clamp
 SD = Straight, Direct Solder
 BS = Bulkhead, Solder Clamp

INTERFACE STANDARD

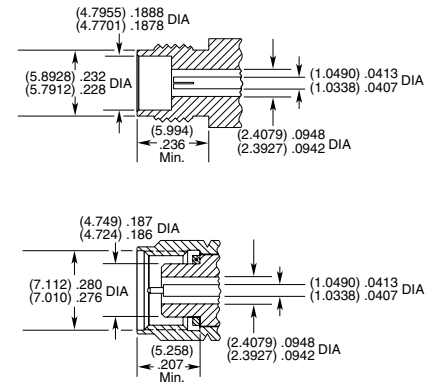

2.40 mm Board Connectors

240

Cable Mates:

RF047-A, RF086, RF085, RF23C, RF120



240

GENDER

-J
= Jack

TYPE

-P
= PCB Mount

PLATING

-EP
= 50 μ"
(1.27 μm) Gold center contact, Passivated outer contact

ORIENTATION

-ST
= Straight

TERMINATION

-CM
= Compression Mount Stripline
-CMM
= Compression Mount Microstrip

OPTION

-1
= without Screws
-2
= With Screws

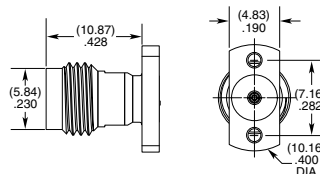

-CM SHOWN

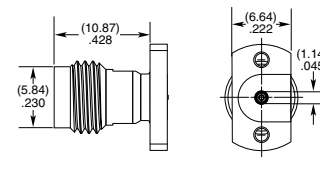

-CMM SHOWN

2.92 mm TO 40 GHz

2.92 mm Cable Assemblies

RF047-A, RF086, RF085, RF23C, RF120



VSWR

RF047-A: 1.35 max.
RF086: 1.40 max.
RF085: 1.40 max.
RF23C: 1.40 max.
RF120: 1.40 max.

SERIES	END 1 CONNECTOR	END 2 CONNECTOR	OVERALL LENGTH
RF047-A = (1.2 mm) .047" overshield DIA 29 AWG millimeter wave cable	-92SJ = 2.92 mm Straight Jack		- "XXXX" = Overall Length in millimeters -0100 (100 mm) 3.94" minimum (RF047-A, RF085, RF086, RF120) -0152 (0152 mm) 5.984" minimum (RF23C)
RF086 = (2.18 mm) .086" overshield DIA 23 AWG millimeter wave cable	-92SP = 2.92 mm Straight Plug		
RF085 = (2.16 mm) .085" overshield DIA 24 AWG millimeter wave cable	ALSO AVAILABLE 1.35 mm, 1.85 mm, 2.40 mm, SMPM = RF047-A 1.85 mm, 2.40 mm, SMPM = RF086 2.40 mm = RF085 2.40 mm, SMPM = RF23C 2.40 mm = RF120		
RF23C = MWC-2350CU-01 millimeter wave cable with copper foil shield			
RF120 = MWC-19550-FCU-01 19 AWG millimeter wave cable			

2.92 mm Cable Connectors

PRF92



CONNECTORS FOR INDUSTRY STANDARD CABLES	
PRF92-P-C-EE-405-SD	RG 405, .085, semi-rigid
PRF92-P-C-EE-085A-SD	.085, semi-rigid, 23AWG
PRF92-P-C-EP-160-SS	Semflex HP160, low loss flexible
PRF92-P-C-EP-150B-SS	IW 1501, low loss flexible
PRF92-P-C-EP-142-SS	Harbour LL142, low loss flexible
PRF92-J-C-EP-085-SS	Harbour SS405, flexible alternative to RG 405
PRF92-J-C-EP-085-BS	Harbour SS405, flexible alternative to RG 405
PRF92-P-C-EP-085-SS	Harbour SS405, flexible alternative to RG 405
PRF92-P-C-EE-402-SD	RG 402, .141, semi-rigid
PRF92-P-C-EP-190-SS	Semflex HP190, low loss flexible
PRF92-J-C-EP-160-SS	Semflex HP160, low loss flexible
PRF92-P-C-EP-120A-SS	Semflex HP120, low loss flexible
PRF92-P-C-EP-140-SS	Dynawave DF140, low loss flexible
PRF92-P-C-EP-047D-SS	.047, semi-rigid
PRF92-J-C-EP-047D-SS	.047, semi-rigid
PRF92-P-C-EP-150-SS	Dynawave DF150, low loss flexible
PRF92-P-C-EE-118-SD	Haverhill HC35004, .118, semi-rigid
PRF92-J-C-EP-402-SS	RG 402, .141, semi-rigid
PRF92-J-C-EP-047D-4S	.047, semi-rigid
PRF92-J-C-EP-405-4S	RG 405, .085, semi-rigid
PRF92-P-C-EE-405-SD	RG 405, .085, semi-rigid
PRF92-P-C-EP-086-SS	.086 Temp-Flex, low loss flexible
PRF92-P-C-EP-200-SS	Times Max Gain 200, low loss flexible

INTERFACE STANDARD

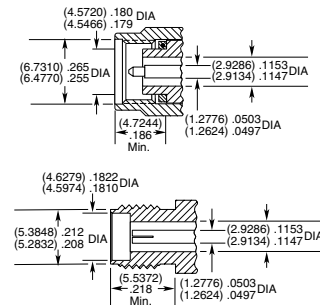

P-C = Cable Plug
 J-P = Cable Jack
 EE = Plating (50 μ" Gold center contact & outer contact)
 EP = Plating (50 μ" Gold center contact, passivated outer contact)
 SS = Straight, Solder Clamp
 SD = Straight, Direct Solder
 BS = Bulkhead, Solder Clamp
 4S = 4-hole flange, Solder Clamp

2.92 mm Board Connectors

Cable Mates:
 RF047-A, RF085, RF086, RF23C, RF120



292	GENDER	TYPE	PLATING	ORIENTATION	TERMINATION
	-J = Jack	-P = PCB Mount	-HP = 30 μ" (0.76 μm) Gold center contact, Passivated outer contact	-ST = Straight	-CM2 = Compression Mount

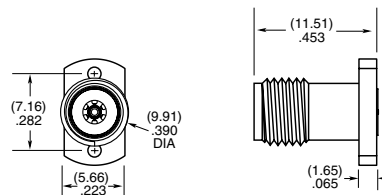

3.50 mm TO 34 GHz

3.50 mm Cable Assemblies RF23S



VSWR

RF23S: 1.30 max

SERIES

RF23S
= MWC-2350-01 microwave cable with 23 AWG solid FEP Dielectric

END 1 CONNECTOR

-35SJP
= 3.50 mm Straight Jack
-35SPP
= 3.50 mm Straight Plug

END 2 CONNECTOR

OVERALL LENGTH

-"XXXX"
= Overall Length in millimeters
-0100 (100 mm) 3.94" min.

3.50 mm Cable Connectors PRF35



CONNECTORS FOR INDUSTRY STANDARD CABLES

PRF35-P-C-EP-405-SS	RG 405, .085, semi-rigid
PRF35-J-C-EP-402-SS	RG 402, .141, semi-rigid
PRF35-J-C-EP-402-BS	RG 402, .141, semi-rigid
PRF35-P-C-EP-402-SS	RG 402, .141, semi-rigid
PRF35-P-C-EP-120A-SS	Semflex HP120, low loss flexible
PRF35-J-C-EP-160-SS	Semflex HP160, low loss flexible
PRF35-P-C-EP-160-SS	Semflex HP160, low loss flexible

P-C = Cable Plug
J-C = Cable Jack
EP = Plating (50 μ" Gold center contact, passivated outer contact)
SS = Straight, Solder Clamp
BS = Bulkhead, Solder Clamp

INTERFACE STANDARD

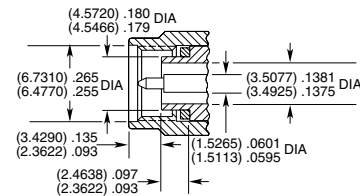
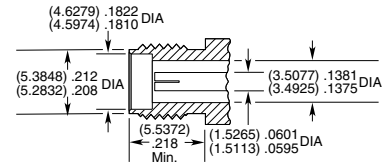

SSMA TO 34 GHz

SSMA Cable Connectors PRFS1



CONNECTORS FOR INDUSTRY STANDARD CABLES

PRFS1-J-C-EE-405-BD	RG 405, .085, semi-rigid
PRFS1-P-C-EE-405-SD	RG 405, .085, semi-rigid
PRFS1-P-C-EP-141A-SS	Harbour SS402, flexible alternative to RG 402

P-C = Cable Plug
J-C = Cable Jack
EE = Plating (50 μ" Gold center contact & outer contact)
EP = Plating (50 μ" Gold center contact, passivated outer contact)
SS = Straight, Solder Clamp
SD = Straight, Direct Solder
BD = Bulkhead, Direct Solder

INTERFACE STANDARD

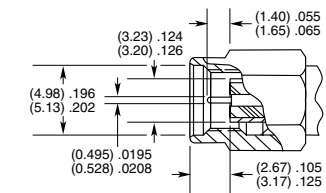
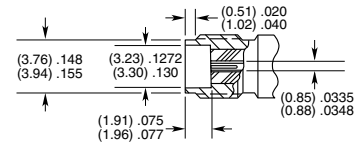

SMA TO 18 GHz

SMA Cable Assemblies

RF25S, RF402, RF405, RF180, RF280



VSWR

RF25S: 1.60 max.
RF402: 1.50 max.
RF405: 1.35 max.
RF180: 1.35 max.
RF280: 1.35 max.

Additional connector options available.
Contact RFGroup@samtec.com

SERIES	END 1 CONNECTOR	END 2 CONNECTOR	OVERALL LENGTH
RF25S = MWC-2550-01 microwave cable with 25 AWG solid FEP dielectric RF402 = RG 402 (.141") 19 AWG semi-flexible microwave cable RF405 = RG 405 (.086") 24 AWG semi-flexible microwave cable RF180 = (4.52 mm) .178" overshield DIA, 16 AWG microwave cable RF280 = (7 mm) .277" overshield DIA, 11 AWG microwave cable	-01SP1* = SMA Straight Plug -01RP1* = SMA Right-angle Plug (RF25S not available) -01BJ1* = SMA Bulkhead Jack (RF402 & RF405 not available)	-"XXXX" = Overall Length in millimeters -0100 (100 mm) 3.94" minimum	

*Remove last "1" from end connector when specifying RF180 & RF280.

ALSO AVAILABLE

SMP = RF25S, RF405

TNCA, N Type = RF180

TNCA, N Type = RF280

SMA Cable Connectors

PRF01



CONNECTORS FOR INDUSTRY STANDARD CABLES	
PRF01-P-C-EP-120B-SS	IW 1201, low loss flexible
PRF01-P-C-EP-120-SS	Harbour LL120, low loss flexible
PRF01-P-C-EP-142-SS	Harbour LL142, low loss flexible
PRF01-P-C-EP-190-SS	Semflex HP190, low loss flexible
PRF01-P-C-EP-335-SS	Harbour LL335, low loss flexible
PRF01-P-C-EP-290-SS	Semflex LA290, low loss flexible
PRF01-P-C-EP-142A-SS	Harbour SB142, low loss flexible
PRF01-P-C-EP-142-RS	Harbour LL142, low loss flexible
PRF01-P-C-EP-190-RS	Semflex HP190, low loss flexible
PRF01-J-C-EP-142-SS	Harbour LL142, low loss flexible
PRF01-P-C-EP-141A-SS	Harbour SS402, flexible alternative to RG 402
PRF01-P-C-EP-160-RS	Semflex HP160, low loss flexible
PRF01-P-C-EP-305-SS	Semflex HP305, low loss flexible
PRF01-P-C-EP-335A-SS	Harbour LL335i, low loss flexible
PRF01-P-C-EE-402-SD	RG 402, .141, semi-rigid
PRF01-P-C-EP-150-SS	Dynawave DF150, low loss flexible
PRF01-J-C-EE-405-SD	RG 405, .085, semi-rigid
PRF01-P-C-EE-047D-SD	.047, semi-rigid
PRF01-J-C-EE-047D-4D	.047, semi-rigid
PRF01-J-C-EE-047D-SD	.047, semi-rigid
PRF01-P-C-EP-160-SS	Semflex HP160, low loss flexible
PRF01-P-C-EE-405-SD	RG 405, .085, semi-rigid
PRF01-P-C-EP-200-SS	Times Max Gain 200, low loss flexible

INTERFACE STANDARD

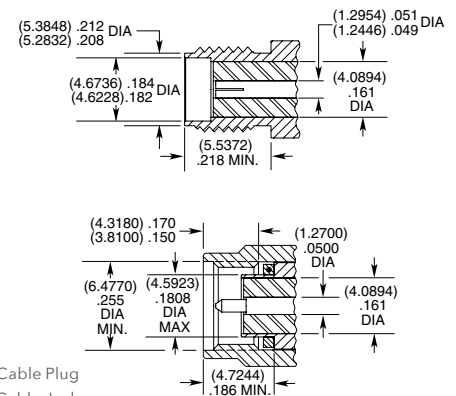

SMA Board Connectors

SMA-TH, SMA-SM, SMA-MT, SMA-EM

Cable Mates:
RF25S, RF402, RF405, RF180, RF280



SMA	GENDER	TYPE	PLATING	ORIENTATION	TERMINATION
	-J = Jack	-P = PCB Mount	-H = 30 μ" (0.76 μm) Gold center contact, 3 μ" (0.08 μm) Gold outer contact -GF = 10 μ" (0.25 μm) Gold center contact, 3 μ" (0.08 μm) Gold outer contact (-SM1 only)	-ST = Straight -RA = Right-angle	-TH1 = Through-hole -SM1 = Surface Mount (-GF-RA only) -EM1 = Edge Mount (-ST only) -EM3 = Drop-in Edge Mount (-ST only) -MT1 = Mixed Technology (-ST only)

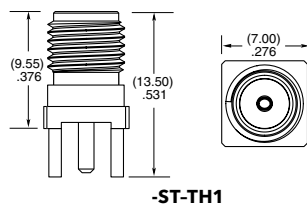

SMMP TO 65 GHz

SMMP Cable Assemblies

RF047-A, RF086, RF23C



VSWR

RF047-A: 1.40 max.
RF086: 1.40 max.
RF23C: 1.40 max.

SERIES	END 1 CONNECTOR	END 2 CONNECTOR	OVERALL LENGTH
RF047-A = (1.2 mm) .047" overshield DIA 29 AWG millimeter cable RF086 = (2.18 mm) .086" overshield DIA 23 AWG millimeter cable RF23C = MWC-2350CU-01 millimeter wave cable with copper foil shield	-M0SP = SMMP Straight Plug, Full Detent -M0SJ = SMMP Straight Jack		-"XXXX" = Overall Length in millimeters -0100 (0100 mm) 3.94" minimum (RF047-A, RF086) -0152 (0152 mm) 5.984" minimum (RF23C)
ALSO AVAILABLE			
1.85 mm, 2.40 mm, 2.92 mm = RF086 1.35 mm, 1.85 mm, 2.40 mm, 2.92 mm = RF047-A 2.40 mm, 2.92 mm = RF23C			

SMMP Cable Connectors

PRFM0



CONNECTORS FOR INDUSTRY STANDARD CABLES	
PRFM0-J-C-EE-047A-BD	.047 Temp-Flex, low loss flexible, 29 AWG
PRFM0-J-C-EE-085-BD	Harbour SS405, flexible alternative to RG 405
PRFM0-J-C-EE-047A-RD	.047 Temp-Flex, low loss flexible, 29 AWG
PRFM0-J-C-EE-086-SD	.086 Temp-Flex, low loss flexible
PRFM0-J-C-EE-047B-SD	.047 Temp-Flex, low loss flexible, 28 AWG
PRFM0-P-C-HG-047A-SD	.047 Temp-Flex, low loss flexible, 29 AWG
PRFM0-J-C-HG-047A-SD	.047 Temp-Flex, low loss flexible, 29 AWG

INTERFACE STANDARD (CATCHERS MITT)

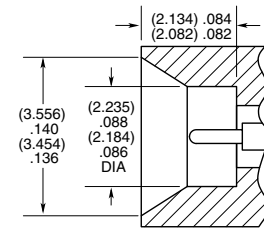

P-C = Cable Plug
J-C = Cable Jack
EE = Plating (50 μ" Gold center contact, & outer contact)
HG = Plating (30 μ" Gold center contact, 10 μ" Gold outer contact)
SD = Straight, Direct Solder
BD = Bulkhead, Direct Solder
RD = Right-angle, Direct Solder

SMMP Board Connectors

SMPM-SM, SMPM-TH, SMPM-RA

Cable Mates:
RF047-A, RF086, RF23C



SMMP	GENDER	TYPE	PLATING	ORIENTATION	TERMINATION	1
	-PF = Full Detent -PS = Smooth Bore -PC = Catchers Mitt (-ST-TH only)	-P = PCB Mount	-HG = 30 μ" (0.76 μm) Gold center contact, 10 μ" (0.25 μm) Gold outer contact (-ST only) -HF = 30 μ" (0.76 μm) Gold center contact, 3 μ" (0.08 μm) Gold outer contact (-RA only) -EE = 50 μ" (1.27 μm) Gold center contact and outer body (-SM only)	-ST = Straight -RA = Right-angle (-TH required)	-EM = Drop-in Edge Mount (-ST only) -TH = Through-hole -SM = Surface Mount (-ST only)	
	<p style="text-align: center;">-ST-SM-1</p>		<p style="text-align: center;">-ST-EM-1</p>	<p style="text-align: center;">-ST-TH-1</p>	<p style="text-align: center;">-RA-TH-1</p>	

SMMP TO 65 GHz

SMMP Bullet Adaptor PRFIA

Mates With:
SMMP, GPPB

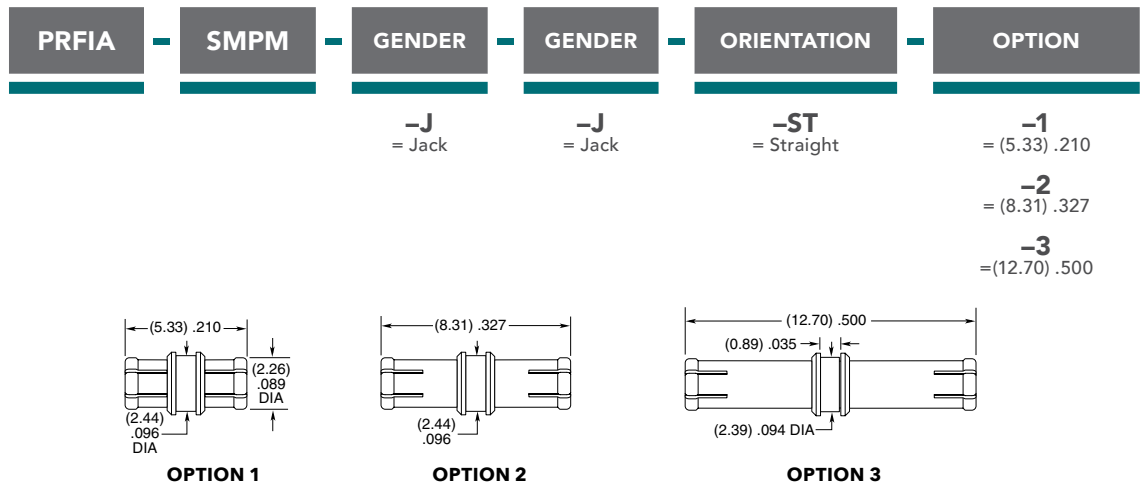

GANGED SMMP SOLUTIONS

BOARD-TO-BOARD GANGED, MULTI-POSITION SMMP BLOCKS

Series: GPPB
Mates with: PRFIA

FEATURES

- High-density, space-saving design
- 8.33 mm (.328") pitch (3.56 mm (.140") pitch in development)
- Push-on interface with varying retention forces
- Bullet adaptors enable blind mate applications accommodating axial and radial misalignment
- Board height options: 5.33 mm (.210"), 8.31 mm (.327"), 12.70 mm (.500")

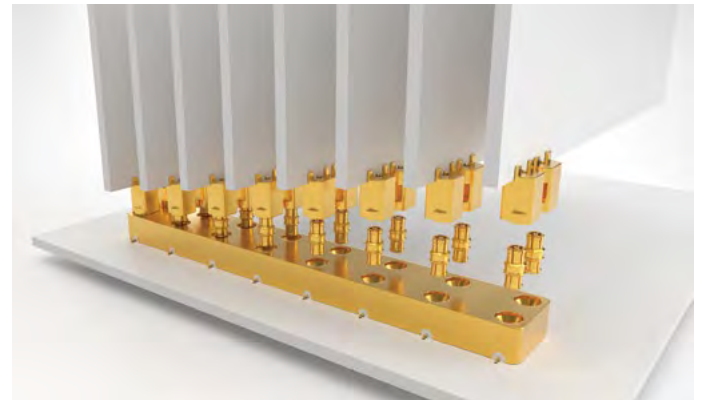

CABLE-TO-BOARD GANGED, MULTI-POSITION SMMP CABLE ASSEMBLY

Cable Assembly: GC47
Board Mate: GPPC

FEATURES

- High-density, space-saving design
- Pitch: 3.56 mm (.140")
- Push-on interface for quick installation
- .047 low-loss flexible microwave/millimeter wave cable

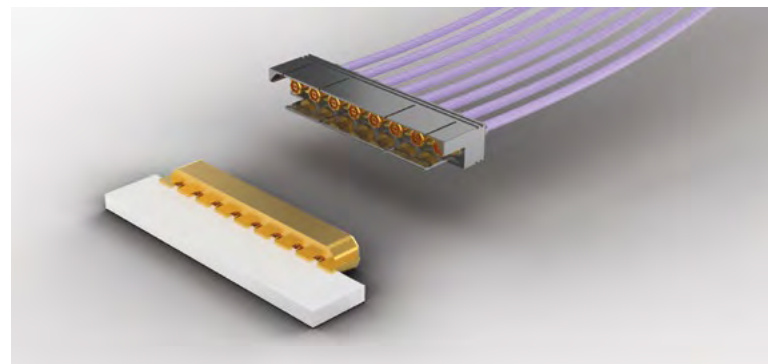

Applications include: 5G wireless, mmWave, military/defense, telecom, radar, test & measurement, applications that are space limited and require high operating frequency

SMP TO 40 GHz

SMP Cable Assemblies

RF25S, RF405



VSWR

RF25S: Contact Samtec
RF405: Contact Samtec

SERIES	END 1 CONNECTOR	END 2 CONNECTOR	OVERALL LENGTH
RF25S = MWC-2550-01 microwave cable with 25 AWG solid FEP dielectric RF405 = RG 405 (.086") 24 AWG semi-flexible microwave cable	-00SJ7 = SMP Straight Jack -00RJ7 = SMP Right-angle Jack		-"XXXX" = Overall Length in millimeters -0100 (100 mm) 3.94" minimum
ALSO AVAILABLE			
SMA = RF25S			
SMA = RF405			

SMP Cable Connectors

PRF00



CONNECTORS FOR INDUSTRY STANDARD CABLES	
PRF00-J-C-EE-047A-RD	.047 Temp-Flex, low loss flexible, 29 AWG
PRF00-J-C-EE-085A-SD	.085, semi-rigid, 23 AWG
PRF00-PF-C-KK-047D-BD	.047, semi-rigid

J-C = Cable Jack
 EE = Plating (50 μ" Gold center contact & outer contact)
 KK = Plating (100 μ" Gold over Nickel center contact, passivated outer contact)
 BD = Bulkhead, Direct Solder
 SD = Straight, Direct Solder
 RD = Right-angle, Direct Solder

INTERFACE STANDARD (FULL DETENT)

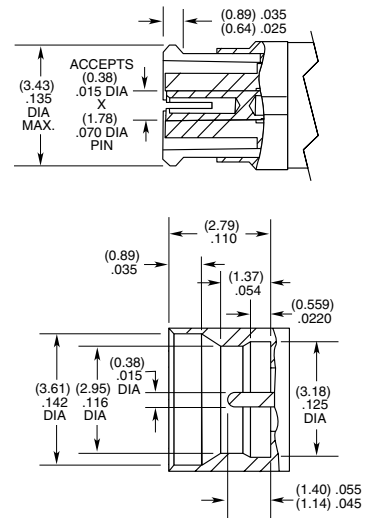

SMP TO 40 GHz

SMP Board Connectors SMP-TH, SMP-EM

Cable Mates:
RF405, RF255



SMP	GENDER	TYPE	PLATING	ORIENTATION	TERMINATION
	-PF = Plug, Full Detent -PL = Plug, Limited Detent -PS = Plug, Smooth Bore -PC = Plug, Catcher's Mitt	-P = PCB Mount	-GF = 10 μ " (0.25 μ m) Gold center contact, Gold Flash outer contact (-TH2 only) -HH = 30 μ " (0.76 μ m) Gold center and outer contact (-EM3)	-ST = Straight	-TH2 = Through-hole -EM3 = Drop-in Edge Mount (Not available with -PC)

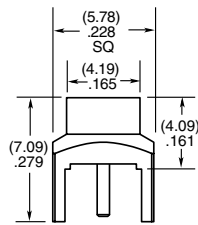

-PF/-PL/-PS-TH2

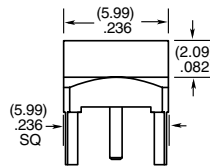

-PC-TH2

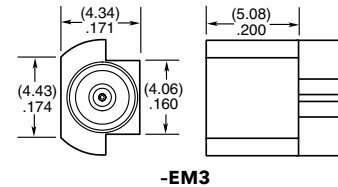

-EM3

SMP Bullet Adaptor SMP-B



SMP	J	TYPE	PLATING	ORIENTATION	BULLET LENGTH
		-B = Bullet Adaptor	-GF = 10 μ " (0.25 μ m) Gold center contact, Gold Flash outer contact	-ST = Straight	-0645 = 6.45 mm (.254") -1450 = 14.50 mm (.571")

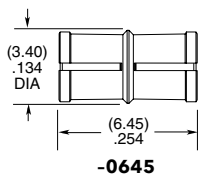

-0645

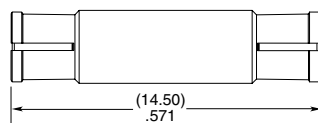

-1450

APPLICATION

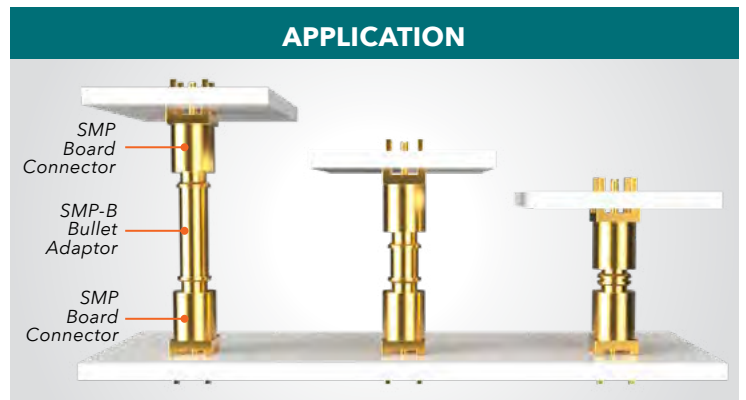

Compensates for axial & radial misalignment

N TYPE TO 18 GHz

N Type Cable Assemblies

RF180, RF280



VSWR

RF180: 1.35 max.
RF280: 1.35 max.

SERIES	END 1 CONNECTOR	END 2 CONNECTOR	OVERALL LENGTH
RF180 = (4.52 mm) .178" overshield DIA, 16 AWG microwave cable RF280 = (7 mm) .277" overshield DIA, 11 AWG microwave cable	-06SP = N Type Straight Plug -06RP = N Type Right-angle Plug -06BJ = N Type Straight Bulkhead Jack		-"XXXX" = Overall length in millimeters -0100 (100 mm) 3.94" minimum

ALSO AVAILABLE

SMA, TNCA = RF180
SMA, TNCA = RF280

PRELIMINARY

N Type Cable Connectors

PRF06



CONNECTORS FOR INDUSTRY STANDARD CABLES	
PRF06-P-C-EP-142-SS	Harbour LL142, low loss flexible
PRF06-P-C-EP-190-SS	Semflex HP190, low loss flexible
PRF06-P-C-EP-335-SS	Harbour LL335, low loss flexible
PRF06-P-C-EP-290-SS	Semflex LA290, low loss flexible
PRF06-P-C-EP-142A-SS	Harbour SB142, low loss flexible
PRF06-P-C-EP-305-SS	Semflex HP305, low loss flexible
PRF06-P-C-EP-335-RS	Harbour LL335, low loss flexible
PRF06-J-C-EP-142-BS	Harbour LL142, low loss flexible
PRF06-J-C-EP-190-BS	Semflex HP190, low loss flexible
PRF06-P-C-EP-120A-SS	Semflex HP120, low loss flexible
PRF06-J-C-EP-402-4S	RG 402, .141, semi-rigid
PRF06-P-C-EP-142-RS	Harbour LL142, low loss flexible
PRF06-P-C-EP-190-RS	Semflex HP190, low loss flexible
PRF06-J-C-EP-290-BS	Semflex LA290, low loss flexible
PRF06-P-C-EP-141A-SS	Harbour SS402, flexible alternative to RG 402
PRF06-J-C-EP-335-BS	Harbour LL335, low loss flexible
PRF06-P-C-EP-335A-SS	Harbour LL335i, low loss flexible
PRF06-P-C-EP-290-RS	Semflex LA290, low loss flexible
PRF06-P-C-EP-300A-SS	Times Max Gain 300, low loss flexible
PRF06-P-C-EP-335A-RS	Harbour LL335i, low loss flexible
PRF06-P-C-EP-160B-SS	ATM CF-210, low loss flexible
PRF06-P-C-EP-270A-RS	Dynawave DF218, low loss flexible

P-C = Cable Plug
J-C = Cable Jack
EP = Plating (50 μm" Gold center contact, passivated outer contact)
SS = Straight, Solder Clamp
RS = Right-angle, Solder Clamp
BS = Bulkhead, Solder Clamp
4S = 4-hole Flange, Solder Clamp

INTERFACE STANDARD

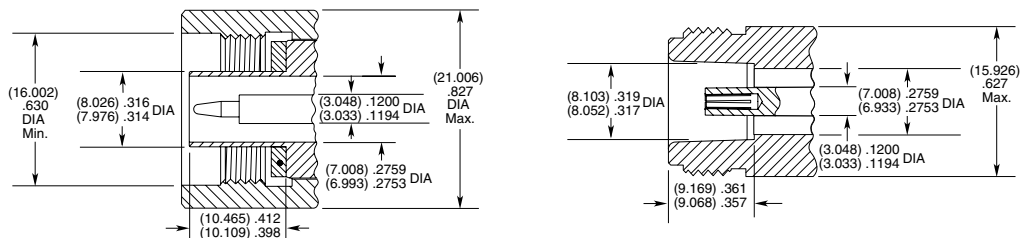

TNCA TO 18 GHz

TNCA Cable Assemblies

RF180, RF280



VSWR

RF180: 1.35 max.
RF280: 1.35 max.

SERIES	END 1 CONNECTOR	END 2 CONNECTOR	OVERALL LENGTH
--------	-----------------	-----------------	----------------

RF180
= (4.52 mm) .178" overshield DIA,
16 AWG microwave cable

RF280
= (7 mm) .277" overshield DIA,
11 AWG microwave cable

-04SP
= TNCA Straight Plug

-04RP
= TNCA Right-angle Plug

-04BJ
= TNCA Straight Bulkhead Jack

-"XXXX"
= Overall length in millimeters

-0100 (100 mm) 3.94"
minimum

ALSO AVAILABLE

SMA, N Type = RF180
SMA, N Type = RF280

PRELIMINARY

TNCA Cable Connectors

PRF04



CONNECTORS FOR INDUSTRY STANDARD CABLES	
PRF04-P-C-EP-142-RS	Harbour LL142, low loss flexible
PRF04-J-C-EP-142-BS	Harbour LL142, low loss flexible
PRF04-P-C-EP-142-SS	Harbour LL142, low loss flexible
PRF04-P-C-EP-335-SS	Harbour LL335, low loss flexible
PRF04-P-C-EP-290-SS	Semflex LA290, low loss flexible
PRF04-J-C-EP-190-BS	Semflex HP190, low loss flexible
PRF04-P-C-EP-190-RS	Semflex HP190, low loss flexible
PRF04-P-C-EP-190-SS	Semflex HP190, low loss flexible
PRF04-P-C-EP-335A-RS	Harbour LL335i, low loss flexible
PRF04-J-C-EP-335A-BS	Harbour LL335i, low loss flexible
PRF04-P-C-EP-300A-SS	Times Max Gain 300, low loss flexible
PRF04-P-C-EP-200-SS	Times Max Gain 200, low loss flexible

P-C = Cable Plug
J-C = Cable Jack
EP = Plating (50 μ" Gold center contact, passivated outer contact)
SS = Straight, Solder Clamp
RS = Right-angle, Solder Clamp
BS = Bulkhead, Solder Clamp

INTERFACE STANDARD

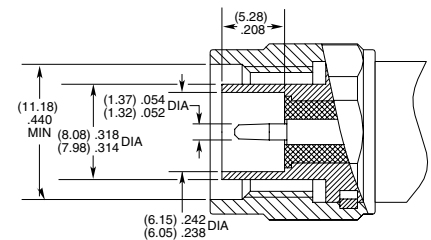
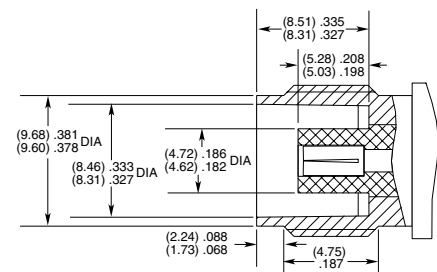

HIGH-PERFORMANCE TEST ASSEMBLIES TO 70 GHz

FEATURES & BENEFITS

The high-density array designs and advanced cabling solutions within Samtec's Bulls Eye® product family support test and measurement applications to 70 GHz.

- Compression interface to the board provides easy on/off and eliminates soldering costs
- High-density, space-saving design
- Enables smaller evaluation boards and shorter trace lengths
- Installation: while the attach process for each series is similar, each have unique specifications that need to be observed



Traditional with SMAs

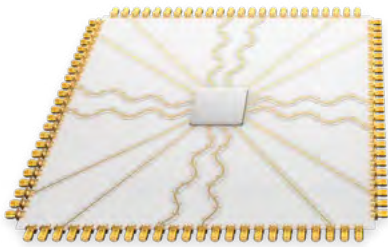

Bulls Eye®



HIGH-DENSITY & SPACE-SAVING

Enables smaller evaluation boards and shorter trace lengths.

PRODUCT FAMILY CROSS REFERENCE GUIDE

ASSEMBLY	70 GHz	50 GHz	40 GHz	20 GHz	
End 2 Connectors	1.85 mm	2.40 mm (50 GHz)	2.92 mm (40 GHz)	2.92 mm (2 Row)	2.92 mm (4 Row)
Samtec Series	BE70A	BE40A		BDRA	BQRA
Cable Type	.086	MWC-2350CU-01		MWC-2350-01	
Cable Management	Yes				
PCB Transmission	Microstrip or Stripline			Stripline	
Design	Spring-Loaded Contact; 360° Grounding 	Pogo-Pin for Signal & Ground 	Fixed-Pin for Signal; Elastomer & Block for Ground 		
No. of Positions	2x 3, 4, 6, 8, 10, 12, 14, 16			2x 12	20
Impedance	50 Ω				
FPGA Development Kit	Xilinx® Zynq® UltraScale™ RFSoc ZCU1275			Xilinx® Virtex® UltraScale™ FPGA VCU110	

70 GHz ASSEMBLIES

BE70A	TRANSMISSION TYPE	END 2	PHASE MATCHING	2	POSITIONS PER ROW	OVERALL LENGTH
	-S = Stripline	-18SJ = 1.85 mm Straight Jack	-2 = 2.0 Pico-second		-03, -04, -06, -08, -10, -12, -14, -16	- "XXXX" = Overall length in millimeters
	-M = Microstrip	-18SP = 1.85 mm Straight Plug	-5 = 5.0 Pico-second			-0152 (0152 mm) 5.984" to -9999 (9999 mm) 393.7"
			-N = No Phase Matching			

BE70A
End 2 Connectors:
1.85 mm (70 GHz)

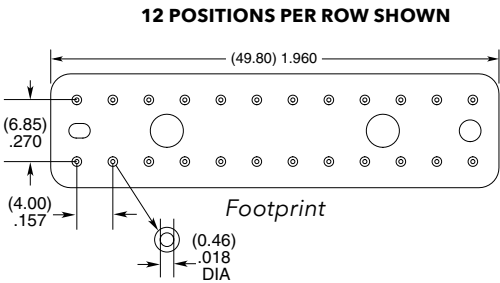

BE70A, 2 X 4 FOOTPRINT, 12-INCH CABLE

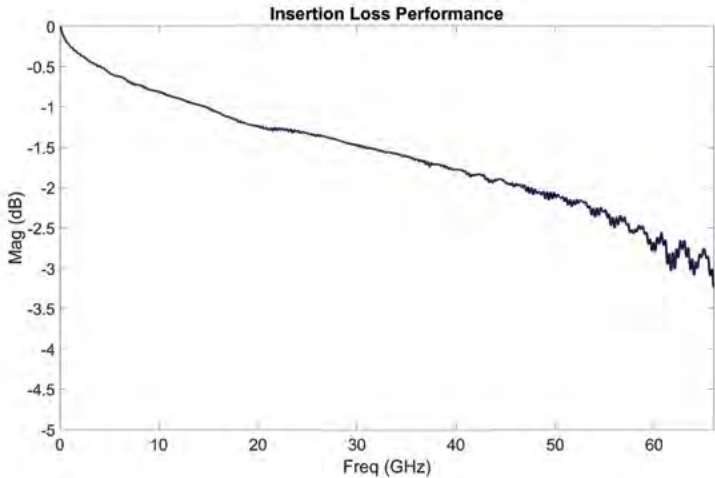

~3 dB LOSS: BREAKOUT REGION + BE70A

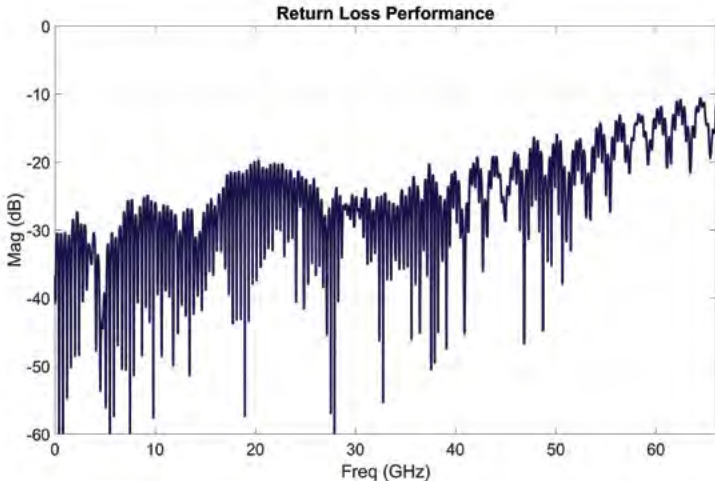

MEASURED: 1.975 mm STRIPLINE + BREAKOUT REGION + BE70A

50 GHz & 40 GHz ASSEMBLIES

BE40A	TRANSMISSION TYPE	END 2	PHASE MATCHING	2	POSITIONS PER ROW	OVERALL LENGTH
	-S = Stripline -M = Microstrip	-92SJ = 40 GHz, 2.92 mm Straight Plug -24SJ = 50 GHz, 2.40 mm Straight Jack -92SP = 40 GHz, 2.92 mm Straight Plug -24SP = 50 GHz, 2.40 mm Straight Plug	-2 = 2.0 Pico-second -5 = 5.0 Pico-second -N = No Phase Matching		-03, -04, -06, -08, -10, -12, -14, -16	- "XXXX" = Overall length in millimeters -0152 (0152 mm) 5.984" to -9999 (9999 mm) 393.7"

BE40A

End 2 Connectors:
2.40 mm (50 GHz)
2.92 mm (40 GHz)

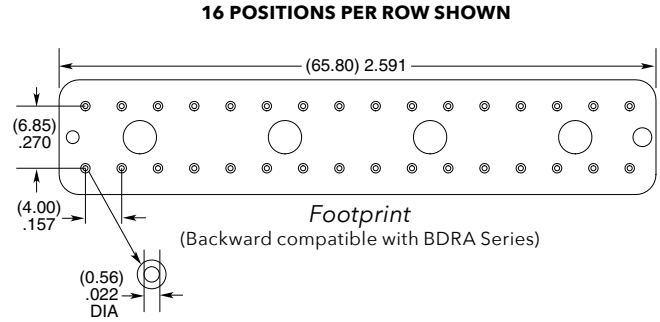

20 GHz ASSEMBLIES

BDRA	END 2	PHASE MATCHING	12	OVERALL LENGTH
	-92SJP = 2.92 mm Straight Jack -92SPP = 2.92 mm Straight Plug	-2 = 2.0 Pico-second -5 = 5.0 Pico-second -10 = 10.0 Pico-second	-12 = Number of phase matched pairs	- "XXXX" = Overall length in millimeters -0100 (100 mm) 3.94" to -9999 (9999 mm) 393.7"

BDRA

End 2 Connectors:
2.92 mm

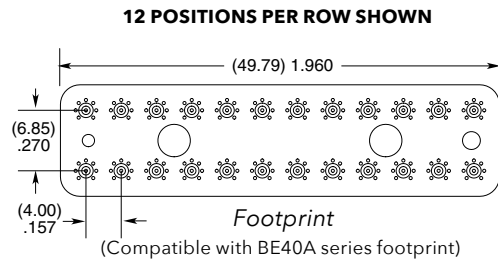
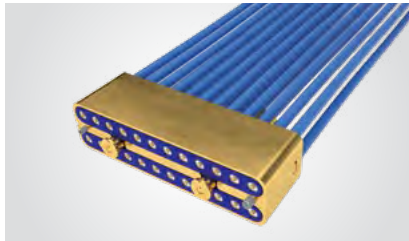

BQRA	END 2	PHASE MATCHING	10	OVERALL LENGTH
	-92SJP = 2.92 mm Straight Jack -92SPP = 2.92 mm Straight Plug	-2 = 2.0 Pico-second -5 = 5.0 Pico-second -10 = 10.0 Pico-second	-10 = Number of phase matched pairs	- "XXXX" = Overall length in millimeters -0100 (100 mm) 3.94" to -9999 (9999 mm) 393.7"

BQRA

End 2 Connectors:
2.92 mm

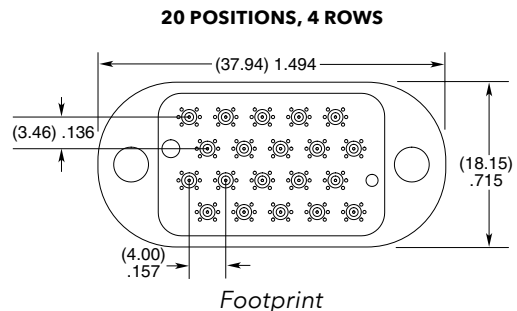

NEXT GENERATION WAVEGUIDE TECHNOLOGY

ULTRA SMALL FORM FACTOR • LOW LOSS DIELECTRIC • FLEXIBLE CABLE

To support the demands of next generation systems, Samtec is developing innovative interconnect solutions such as our new mmWave technology, which enables a high-frequency, ultra-small form factor, and highly flexible waveguide design.

Samtec High-Frequency Micro Waveguides offer high-performance at a lower overall cost than traditional metallic waveguides. Products currently in testing:

- Threaded Termination Cable and mating PCB Launch Right-Angle Connector
- In Development: Push-Pull Style Mini Termination Cable and mating PCB Launch Right-Angle Connector
- Roadmap: Low Loss Dielectric Push-Pull Mini Termination Cable and Vertical PCB Launch Connector
- Adaptors to traditional waveguide interfaces also available

Contact RFGroup@samtec.com for additional details.

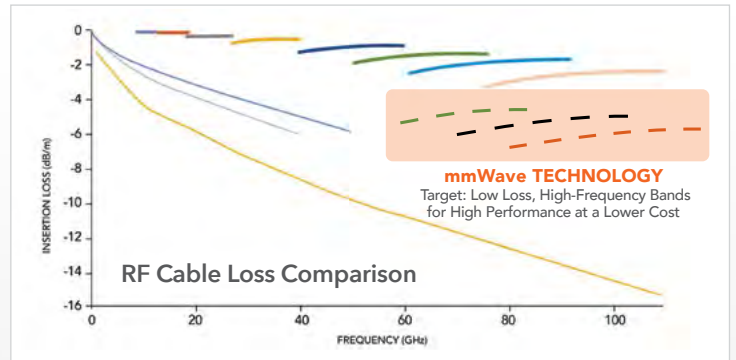

STANDARD LOW LOSS MICROWAVE CABLE

- Samtec
- Competitor 1
- Competitor 2

EXISTING RIGID WAVEGUIDE TECHNOLOGY

- WR90
- WR42
- WR19
- WR12
- WR62
- WR28
- WR15
- WR10

Flexible Cable Construction



Low Loss Dielectric
(Target: 8 dB/meter)

Stripline Routing



Push-Pull Mini Termination Cable & PCB Launch Right-Angle Connector
(In Development)

Ultra-Small Form Factor

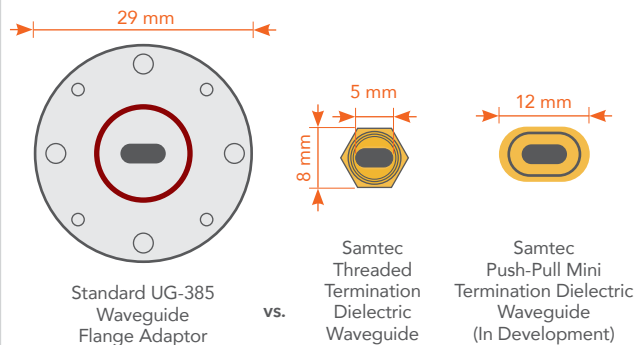

LOW-FREQUENCY CABLES

STANDARD OFF-THE-SHELF ASSEMBLIES

TYPE		50 Ω CABLES						75 Ω CABLES						100 Ω CABLES
		RG 178	CTB-2650F-01	RG 174	RG 316	RG 316 DS	RG 58	RG 179	BELDEN 1855A	BELDEN 1694A	BELDEN 4855R	BELDEN 4694R	RG 6	TPS-28100-RF
ELECTRICAL														
Impedance	Ω	50 ± 2		50 ± 5	50 ± 2	50 ± 3		75 ± 3						100 ± 5
Insertion Loss (dB/m)	100 MHz	0.50	0.68	0.40	0.30	1.4 @ 2 GHz	0.20	0.30	0.12	0.07	0.12	0.06	0.07	-----
	1 GHz	1.70	2.37	1.40	1.25	1.6 @ 3 GHz	0.80	0.80	0.37	0.21	0.36	0.19	0.21	-----
	6 GHz	5.90	6.53	4.40	4.25	2.2 @ 5 GHz	5.40	3.60	0.97	0.59	0.91	0.51	0.59	-----
Propagation Delay	nS/m	4.83	4.17	5.06	4.83	-----	5.05	4.83	4.12	4.06		3.92	4.03	-----
Current Rating	Amps	3	3	5	5	-----	-----	3	5	-----	4.70	16	-----	-----
Capacitance	pF/m	96	85.6	101	96	95.8	102	64	55.7	53.14	53.40	52.20	53.14	38
CONSTRUCTION														
Center Conductor	Material	Silver Plated Copper Clad Steel	Silver Plated Copper	Bare Copper	Silver and Copper Plated Steel	Silver Plated Copper Clad Steel	Tinned Copper	Silver Plated Copper	Bare Copper		Silver Plated Copper		Bare Copper	Silver Plated Copper
	AWG	30	26	26	26	26	20	30	23	18	23	18	18	28
Dielectric	Material	PTFE	Foamed FEP	KLPE	PTFE	FEP	Solid Polyethylene	PTFE	FHDPE	FHDPE	PE (Foam)		FHDPE	FEP
Shield	Material	Silver Plated Copper		Tinned Copper	Silver Plated Copper		Tinned Copper	Silver Plated Copper	1. Al Foil-Polyester Tape-Al Foil 2. Tinned Copper	1. Bonded Al Foil 2. Al Wire	1. Al Foil-Polyester Tape-Al Foil 2. Tinned Copper		Silver Plated Copper	
Jacket	Material	FEP		PVC	FEP		PVC	FEP	PVC	PVC	PVC		PVC	PVC
	Temp Rating	-50 °C to +165 °C	-40 °C to +200 °C	-20 °C to +80 °C	-55 °C to +165 °C	-----	-50 °C to +90 °C	-50 °C to +165 °C	-30 °C to +75 °C	-30 °C to +75 °C	-30 °C to +75 °C	-20 °C to +75 °C	-30 °C to +75 °C	-20 °C to +105 °C
MECHANICAL														
Bend Radius	Min	10.2 mm	3.175 mm	25.4 mm	12.7 mm	12.8 mm	48.3 mm	10.2 mm	38.1 mm	69.85 mm	41 mm	70 mm	69.85 mm	19.05 mm
Connector Options		MMCX, MCX, SMA, SMB, BNC, TNC, N Type	IsoRate®	MMCX, MMCXV, MCX, SMA, SMB, BNC, TNC, N Type, Ganged		MMCX, MCX, SMA, BNC, TNC	SMA, TNC, N Type	MCX, MMCX7, SMB, BNC, DIN 1.0/2.3, Ganged	HD-BNC™, DIN 1.0/2.3	BNC, HD-BNC™, DIN 1.0/2.3	HD-BNC™, DIN 1.0/2.3	BNC, HD-BNC™, DIN 1.0/2.3		CJT
PART NUMBER														
Series		RF178	IJ5C	RF174	RF316, IJ5C, IJ5H, GRF1-C, GRF1H-C	RS316	RF058	RF179, GRF7-C, GRF7H-C	RFB8T	RFB6T	RFC8T	RFC6T	RFA6T	C28S

50 Ω MICRO HIGH FREQUENCY RF CABLES TO 6 GHz

MHF Cable Assemblies MH081, MH113



SPECIFICATIONS

Outer Contact Material:
Au plated Phosphor Bronze
Center Contact Material:
Au plated Phosphor Bronze (MHX)
Au plated BeCu (SMA)
Insulator Material:
PBT (MHX)
PTFE (SMA)
Operating Temperature:
-40 °C to +90 °C
Voltage Rating:
170 V max
Dielectric Withstanding Voltage:
200 Vrms

0.81 mm Cable:

Capacitance:
100 pF/meter
Max Attenuation (cable only):
3.1 dB @ 1 GHz
Conductor Size:
36 AWG, (0.81 mm) .032" dia.
Conductor Material:
Silver Plated Copper
Conductor Resistance:
1.40 Ωv/meter max
Insulator Diameter:
(0.4 mm) .016"
Insulator Material: FEP
Shield Material:
Silver Plated Copper
Jacket Material: PFA
Jacket Diameter:
(0.81 mm) .032" dia.
Bend Radius: 5.0 mm
Jacket Temp Rating:
-40 °C to +90 °C

1.13 mm Cable:

Capacitance:
95 pF/meter
Max Attenuation (cable only):
2 dB @ 1 GHz
Conductor Size:
32 AWG, (1.13 mm) .045" dia.
Conductor Material:
Silver Plated Copper
Conductor Resistance:
0.60 Ωv/meter max
Insulator Diameter:
(0.66 mm) .026"
Insulator Material:
FEP
Shield Material:
Tinned Copper
Jacket Material:
FEP
Jacket Diameter:
(1.13 mm) .045" dia
Bend Radius:
6.8 mm
Jacket Temp Rating:
-40 °C to +90 °C

SERIES	END 1 CONNECTOR	END 2 CONNECTOR	OVERALL LENGTH
--------	-----------------	-----------------	----------------

MH081
= 0.81 mm Cable
MH113
= 1.13 mm Cable

Specify END OPTIONS from chart

-0030
= 1.18" (30 mm)
-0050
= 1.97" (50 mm)
-0100
= 3.94" (100 mm)
-0150
= 5.91" (150 mm)
-0300
= 11.81" (300 mm)

APPLICATION

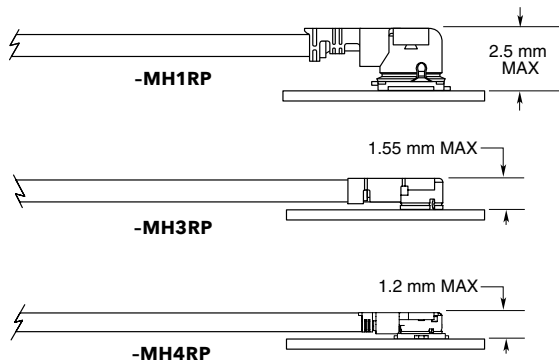

EXTRACTION TOOLS

MH1RP = RSP-122893-01
MH3RP = RSP-122893-02
MH4RP = RSP-122893-03

MATING SOLUTIONS

MH1RP end mates with RSP-122811-01 (Cycles: 30 max.)

MH3RP end mates with RSP-122811-02

MH4RP end mates with RSP-122811-03



END OPTIONS

<p>-MH1RP = MHF1 Type Plug (3.9 μ" (0.1 μm) Gold on Center Contact, 1.9 μ" (0.05 μm) Gold on Shell)</p>	
<p>-MH3RP = MHF3 Type Plug (3.9 μ" (0.1 μm) Gold on Center Contact, 1.9 μ" (0.05 μm) Gold on Shell) (MH081 only)</p>	
<p>-MH4RP = MHF4 Type Plug (10 μ" (0.25 μm) Gold on Center Contact, 1.9 μ" (0.05 μm) Gold on Shell) (MH4RP is not available with MH1RP & MH3RP) (MH081 only)</p>	
<p>-01BJ1 = SMA Straight Bulkhead Jack (MH081 only) -01BJ2 = SMA Straight Bulkhead Jack, Reversed Polarity -01SB1 = SMA Straight Jack, Sealed Bulkhead -01SR1 = SMA Straight Jack, Sealed Bulkhead, Reversed Polarity (30 μ" (0.76 μm) Gold on Center Contact, Gold Flash on Shell)</p>	
<p>-SING = Single Ended (End 2 callout)</p>	
<p>XXXXXX = Stripped & Tinned (End 2 callout)</p>	

STRIPPED & TINNED (Dimensions in mm)

CALLOUT	A	B	C
-303030	3.0	3.0	3.0
-303040	3.0	3.0	4.0
-403030	4.0	3.0	3.0
-403040	4.0	3.0	4.0
-404040	4.0	4.0	4.0

Both center conductor and braid shield are stripped, only the centerconductor is tinned.

50 Ω SMA TO 6 GHz

SMA Cable Assemblies

RF174, RF178, RF316, RS316, RF058



SERIES	END 1 CONNECTOR	END 2 CONNECTOR	OVERALL LENGTH
RF174 = RG 174 Cable	-01SP1 = SMA Straight Plug		-“XXXX” = Overall Length in millimeters
RF178 = RG 178 Cable (-01BJ1 & -01BR1 only)	-01RP1 = SMA Right-angle Plug		-0100 (100 mm) 3.94" minimum
RF316 = RG 316 Cable, Single Braid Shield	-01BJ1 = SMA Straight Bulkhead Jack		
RS316 = RG 316 Cable, Double Shield (-01SP1 & -01BJ1 only)	-01SB1 = Straight Bulkhead Jack, Sealed		
RF058 = RG 58 Cable, (-01SP1, -01BJ1 & 01SB1 only)	-01SR1 = Straight Bulkhead Jack, Sealed, Reversed Polarity		
	-01BR1 = Straight Bulkhead Jack, Sealed, Reversed Polarity		
	-01PN1 = 4-Hole Panel Mount Jack		

ALSO AVAILABLE

50 Ω: MCX, MMCX, SMB, BNC, TNC, N Type = RF174, RF178, RF316

50 Ω: MCX, MMCX, BNC, TNC = RS316

50 Ω: TNC = RF058

SMA Cable Connectors

SMA-CA



Supplied with pins, washers, nuts and ferrules. See website for dimensions.

SMA	GENDER	TYPE	PLATING	ORIENTATION	TERMINATION
	-J = Jack	-C = Cable -C4 = Cable 4-Mounting Screws (-PN1 only)	-H = 30 μ" (0.76 μm) Gold center contact, 3 μ" (0.08 μm) Gold outer contact (N/A with -BH1S)	-ST = Straight	-BH1 = Bulkhead RG 174 / 316 Cable -BH2 = Bulkhead RG 178 Cable -BR1 = Bulkhead RG 174 / 316, Reversed Polarity -BR2 = Bulkhead RG 178 Cable, Reversed Polarity
			-HF = 30 μ" (0.76 μm) Gold center contact, 3 μ" (0.08 μm) Gold outer contact (-BH1S only)		-BH1S = Bulkhead RG 316 Cable, Double Shield -B10 = Bulkhead RG 58 Cable -PN1 = 4-Hole Panel Mount RG 174 / 316 Cable -S10 = Sealed Bulkhead RG 58 Cable

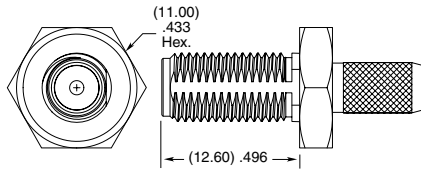

-S10, -B10



SMA Board Connectors

See page 145 for Board Connectors

SMA	GENDER	TYPE	PLATING	ORIENTATION	TERMINATION
	-P = Plug	-C = Cable	-H = 30 μ" (0.76 μm) Gold center contact, 3 μ" (0.08 μm) Gold outer contact (-CA1, -C10 only)	-ST = Straight -RA = Right-angle	-CA1 = RG 174 / 316 Cable -C10 = RG 58 Cable (-ST only) -CA1S = RG 316 Double Shielded Cable (-ST only)
			-HF = 30 μ" (0.76 μm) Gold center contact, 3 μ" (0.08 μm) Gold outer contact (-CA1S only)		

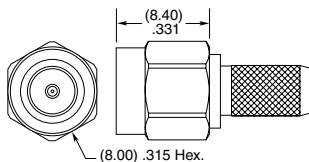

-ST-C10

Supplied with pins, washers, nuts and ferrules. See website for dimensions.

50 Ω MCX TO 6 GHz

MCX Cable Assemblies

RF174, RF178, RF316, RS316



SERIES	END 1 CONNECTOR	END 2 CONNECTOR	OVERALL LENGTH
RF174 = RG 174 Cable	-02SJ1 = MCX Straight Jack		-“XXXX” = Overall Length in millimeters
RF178 = RG 178 Cable	-02RP1 = MCX Right-angle Plug (RS316 not available)		-0100 (100 mm) 3.94" minimum
RF316 = RG 316 Cable, Single Braid Shield	-02SP1 = MCX Straight Plug		
RS316 = RG 316 Cable, Double Shielded			

ALSO AVAILABLE

50 Ω: MMCX, SMA, SMB, BNC, TNC,

N Type = RF174, RF178, RF316

50 Ω: MMCX, SMA, BNC, TNC = RS316

MCX Cable Connectors

MCX-CA



CONNECTORS FOR INDUSTRY STANDARD CABLES	
MCX-J-C-H-ST-CA1	RG 174/316 Cable
MCX-J-C-H-ST-CA2	RG 178 Cable
MCX-J-C-HF-ST-CA1S	RG 316 Double Shielded Cable
MCX-P-C-H-ST-CA1	RG 174/316 Cable
MCX-P-C-H-ST-CA2	RG 178 Cable
MCX-P-C-HF-ST-CA1S	RG 316 Double Shielded Cable
MCX-P-C-H-RA-CA1	RG 174/316 Cable
MCX-P-C-H-RA-CA2	RG 178 Cable

P-C = Cable Plug

J-C = Cable Jack

H or HF = Plating (30 μ" Gold center contact, 3 μ" Gold outer contact)

ST = Straight

RA = Right-angle

Supplied with pins and ferrules. See website for dimensions.

TYPE (-RA)	A	B
-P-CA1	(7.78) .306	(9.50) .374
-P-CA2	(8.58) .338	(10.00) .394

TYPE (-ST)	E	F
-J-CA1	(4.50) .177	(15.50) .610
-J-CA2	(4.78) .188	(15.00) .591
-J-CA1S	(4.50) .177	(15.50) .610

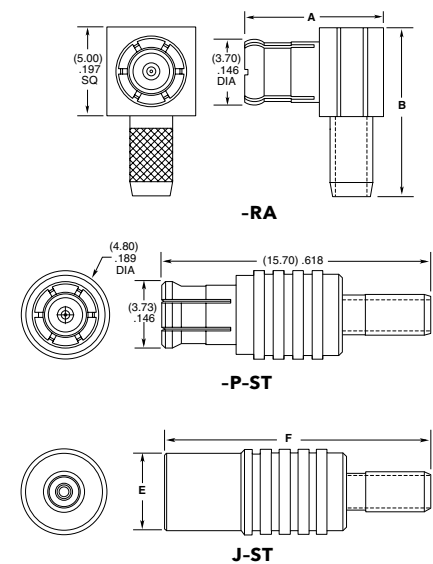

MCX Board Connectors

MCX-TH, MCX-SM, MCX-EM, MCX-MT

Cable Mates:
RF174, RF178, RF316, RS316, GRF1H-C, IJ5H



MCX	GENDER	TYPE	PLATING	ORIENTATION	TERMINATION
	-J = Jack	-P = PCB Mount	-H = 30 μ" (0.76 μm) Gold center contact, 3 μ" (0.08 μm) Gold outer contact	-ST = Straight	-TH1 = Through-hole (-ST plug not available)
	-P = Plug			-RA = Right-angle	-TH2 = Elevated Through-hole (-ST plug only)
					-SM1 = Surface Mount (Jack only)
					-EM1 = Edge Mount (-ST Jack only)
					-MT1 = Mixed Technology (-ST Jack only)

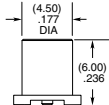
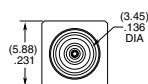

-ST-SM1 (Jack)

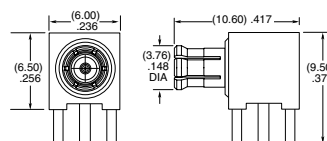

-RA-TH1 (Plug)

50 Ω MMCX TO 6 GHz

MMCX Cable Assemblies

RF174, RF178, RF316, RS316



SERIES	END 1 CONNECTOR	END 2 CONNECTOR	OVERALL LENGTH
RF174 = RG 174 Cable	-03SP1 = MMCX Straight Jack		-“XXXX” = Overall Length in millimeters -0100 (100 mm) 3.94" minimum
RF178 = RG 178 Cable (-03SP1 & -03RP1 only)	-03RP1 = MMCX Right-angle Plug		
RF316 = RG 316 Cable, Single Braid Shield	-V3SP1 = MMCXV Straight Plug, High Vibration		
RS316 = RG 316 Cable, Double Shielded (-03SP1 only)	-V3RP1 = MMCXV Right-angle Plug, High Vibration		
		-V3SJ1 = MMCXV Straight Jack, High Vibration	

ALSO AVAILABLE

50 Ω: MCX, SMA, SMB, BNC, TNC,
N Type = RF174, RF178, RF316
50 Ω: MCX, SMA, BNC, TNC = RS316

MMCX Cable Connectors

MMCX-CA



CONNECTORS FOR INDUSTRY STANDARD CABLES	
MMCX-P-C-H-ST-CA1	RG 174/316 Cable
MMCX-P-C-H-ST-CA2	RG 178 Cable
MMCX-P-C-HF-ST-CA1S	RG 316 Double Shielded Cable
MMCX-P-C-H-RA-CA1	RG 174/316 Cable
MMCX-P-C-H-RA-CA2	RG 178 Cable

P-C = Cable Plug
H or HF = Plating (30 μ" Gold center contact,
3 μ" Gold outer contact)
ST = Straight
RA = Right-angle

Supplied with pins and ferrules.
See website for dimensions.

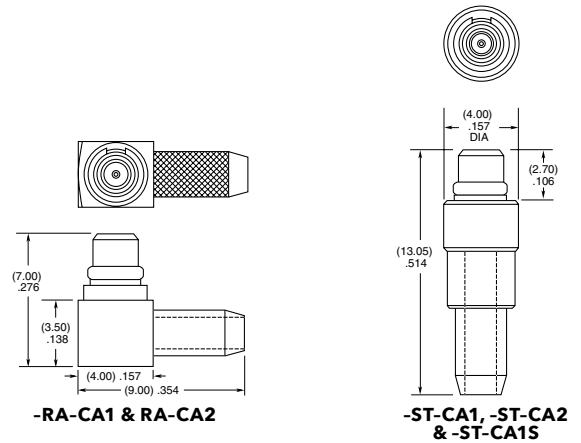

MMCX Board Connectors

MMCX-SM, MMCX-TH, MMCX-MT, MMCX-EM

Cable Mates:
RF174, RF178, RF316, RS316, GRF1H-C, IJ5H



MMCX	GENDER	TYPE	PLATING	ORIENTATION	TERMINATION
	-J = Jack	-P = PCB Mount	-H = 30 μ" (0.76 μm) Gold center contact, 3 μ" (0.08 μm) Gold outer contact	-ST = Straight -RA = Right-angle	-TH1 = Through-hole -MT1 = Mixed Technology (-ST only) -SM1 = Surface Mount (-RA plug not available) -EM1 = Edge Mount (-ST only)
	-P = Plug				

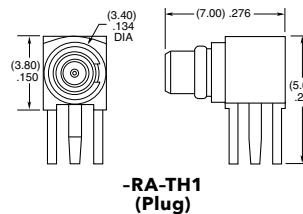
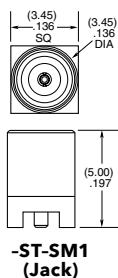

50 Ω TNC TO 6 GHz

TNC Cable Assemblies

RF174, RF178, RF316, RS316, RF058



SERIES	END 1 CONNECTOR	END 2 CONNECTOR	OVERALL LENGTH
RF174 = RG 174 Cable	-05SP3 = TNC Straight Plug (RF058 not available)		-“XXXX” = Overall Length in millimeters
RF178 = RG 178 Cable	-05BJ3 = TNC Straight Bulkhead Jack (RS316 & RF058 not available)		-0100 (100 mm) 3.94” minimum
RF316 = RG 316 Cable, Single Braid Shield	-05SR3 = TNC Straight Plug, Reversed Polarity (RF058 only)		
RS316 = RG 316 Cable, Double Shielded			
RF058 = RG 58 Cable			

ALSO AVAILABLE

50 Ω: MCX, MMCX, SMA, SMB, BNC,
N Type = RF174, RF178, RF316

50 Ω: MCX, MMCX, SMA, BNC = RS316

50 Ω: SMA, N Type = RF058

TNC Cable Connectors

TNC-CA



Supplied with pins, washers, nuts and ferrules. See website for dimensions.

CONNECTORS FOR INDUSTRY STANDARD CABLES	
TNC-P-C-GN-ST-CA1	RG 174/316 Cable
TNC-P-C-GN-ST-CA2	RG 178 Cable
TNC-P-C-GN-SR-C10	RG 58 Cable
TNC-J-C-GN-ST-BH1	RG 174/316 Cable, Bulkhead
TNC-J-C-GN-ST-BH2	RG 178 Cable, Bulkhead

P-C = Cable Plug
J-C = Cable Jack
GN = Plating (10 μm Gold on contact, Nickel on body)
ST = Straight
SR = Straight Reverse Polarity

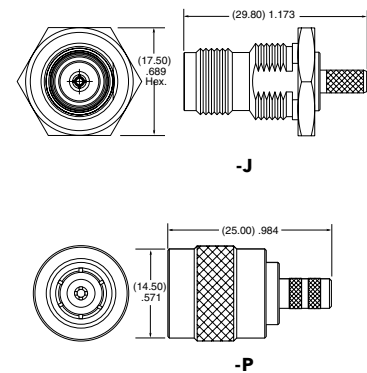

TNC Board Connectors

TNC-TH

Cable Mates:
RF174, RF178, RF316, RS316, RF058, GRF1H-C



TNC	GENDER	TYPE	PLATING	ORIENTATION	TERMINATION
	-J = Jack	-P = PCB Mount	-H = 30 μm (0.76 μm) Gold center contact, Nickel on shell	-RA = Right-angle	-TH1 = Through-hole

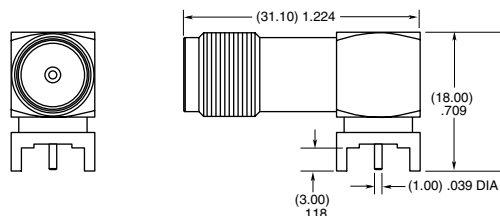

50 Ω BNC TO 4 GHz

BNC Cable Assemblies RF174, RF178, RF316, RS316



SERIES	END 1 CONNECTOR	END 2 CONNECTOR	OVERALL LENGTH
RF174 = RG 174 Cable	-04SP3 = BNC Straight Plug (RS316 not available)	-04BJ2 = BNC Bulkhead Jack	-"XXXX" = Overall Length in millimeters -0100 (100 mm) 3.94" minimum
RF178 = RG 178 Cable			
RF316 = RG 316 Cable, Single Braid Shield			
RS316 = RG 316 Cable, Double Shielded			
ALSO AVAILABLE			
50 Ω: MCX, MMCX, SMA, SMB, TNC, N Type = RF174, RF178, RF316			
50 Ω: MCX, MMCX, SMA, TNC = RS 316			

BNC Cable Connectors BNC5-CA



Supplied with pins, washers, nuts, gaskets and ferrules. See website for dimensions.

CONNECTORS FOR INDUSTRY STANDARD CABLES	
BNC5-P-C-GN-ST-CA1	RG 174/316 Cable
BNC5-P-C-GN-ST-CA2	RG 178 Cable
BNC5-J-C-GN-ST-BH1	RG 174/316 Cable, Bulkhead
BNC5-J-C-GN-ST-BH2	RG 178 Cable, Bulkhead
BNC5-J-C-GN-ST-BH1S	RG 316 Double Shielded Cable, Bulkhead

P-C = Cable Plug
J-C = Cable Jack
GN = Plating (10 μ" Gold on contact, Nickel on body)
ST = Straight

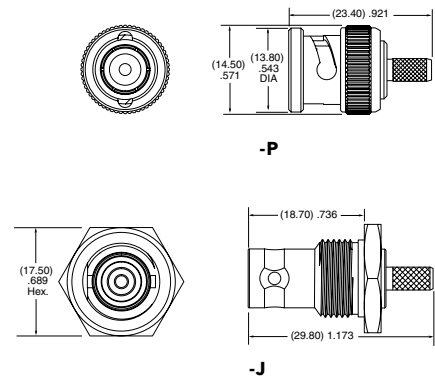

50 Ω SMB TO 4 GHz

SMB Cable Assemblies

RF174, RF178, RF316



SERIES	END 1 CONNECTOR	END 2 CONNECTOR	OVERALL LENGTH
RF174 = RG 174 Cable	-07SP1 = SMB Straight Plug		-“XXXX” = Overall Length in millimeters -0100 (100 mm) 3.94" minimum
RF178 = RG 178 Cable	-07RP1 = SMB Right-angle Plug		
RF316 = RG 316 Cable, Single Braid Shield	-07BJ1 = SMB Bulkhead Jack		
	-07BJ2 = SMB Bulkhead Jack (RF178 only)		

ALSO AVAILABLE

50 Ω: MCX, MMCX, SMA, BNC, TNC,
N Type = RF174, RF178, RF316

SMB Cable Connectors

SMB5-CA



CONNECTORS FOR INDUSTRY STANDARD CABLES	
SMB5-P-C-H-ST-CA1	RG 174/316 Cable
SMB5-P-C-H-RA-CA1	RG 174/316 Cable
SMB5-J-C-H-ST-CA2	RG 178 Cable
SMB5-J-C-H-ST-BH1	RG 316 Cable, Bulkhead

P-C = Cable Plug
J-C = Cable Jack
H = Plating (30 μ" Gold center contact,
3 μ" Gold on outer contact)
ST = Straight
RA = Right-angle

Supplied with pins, washers, nuts and ferrules. See website for dimensions.

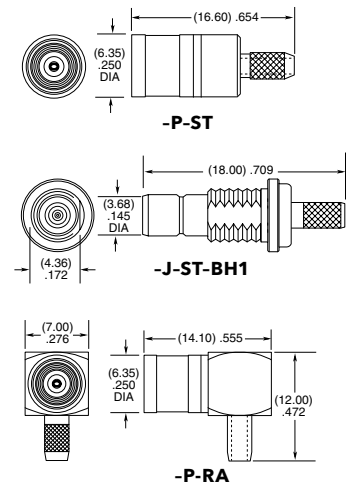

SMB Board Connectors

SMB5-TH

Cable Mates:
RF174, RF178, RF316,
GRF1H-C, IJ5H

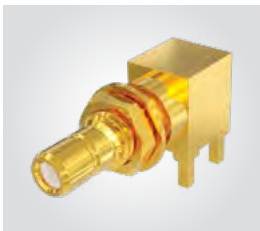

SMB5	GENDER	TYPE	PLATING	ORIENTATION	TERMINATION
	-J = Jack	-P = PCB Mount	-H = 30 μ" (0.76 μm) Gold center contact, 3 μ" (0.08 μm) Gold outer contact	-RA = Right-angle	-TH1 = Through-hole

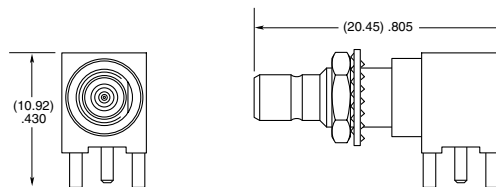



75 Ω BNC TO 12 GHz

BNC Cable Assemblies

RFC6T, RFA6T, RFB6T, RF179



SERIES	END 1 CONNECTOR	END 2 CONNECTOR	OVERALL LENGTH
RFC6T* = 12G-SDI, Belden 4694R Cable	-74SP3 = 75 Ω BNC Straight Plug		-“XXXX” = Overall Length in millimeters -0300 (300 mm) 11.81" minimum (RFA6T, RFB6T, RFC6T) -0100 (100 mm) 3.94" minimum (RF179)
RFA6T = RG 6 Cable	-D4SP3 = 75 Ω BNC Die Cast Straight Plug		
RFB6T = Belden 1694A Cable	-74BJ3 = 75 Ω BNC Bulkhead Jack (RF179 only)		
RF179 = RG 179 Cable	-74RP3 = 75 Ω BNC Right-angle Plug (RFA6T, RFB6T, RFC6T only)		

ALSO AVAILABLE

75 Ω: DIN 1.0/2.3, HD-BNC™ = RFA6T, RFB6T, RFC6T

75 Ω: DIN 1.0/2.3, SMB, MCX, MMCX = RF179

*Designed to meet SMPTE 2082 12G-SDI specifications.

BNC Cable Connectors

BNC7T-CA



Supplied with pins, washers, nuts, gaskets and ferrules. See website for dimensions.

CONNECTORS FOR INDUSTRY STANDARD CABLES	
BNC7T-P-C-GN-ST-CA3	Machined, RG 179 Cable
BNC7T-P-C-GN-RA-CA3	Machined, RG 179 Cable
BNC7T-P-C-GN-ST-CA6	*Machined, RG 6, Belden 1694A or Belden 4694R Cable
BNC7T-P-C-GN-RA-CA6	*Machined, RG 6, Belden 1694A or Belden 4694R Cable
BNC7T-J-C-GN-ST-BH3	Machined, Bulkhead, RG 179 Cable
BNC7T-P-C-GN-ST-CA3D	Die Cast, RG 179 Cable
BNC7T-P-C-GN-ST-CA6D	Die Cast, RG 179 Cable

P-C = Cable Plug
J-C = Cable Jack
GN = Plating (10 μ" Gold on contact, Nickel on outer contact and shell)
ST = Straight
RA = Right-angle

*Designed to meet SMPTE 2082 12G-SDI specifications.

DIE CAST

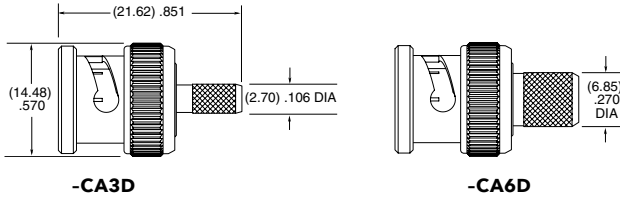

MACHINED

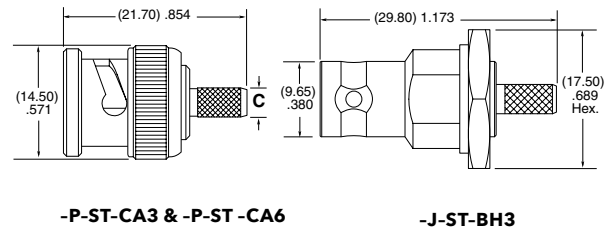

TERMINATION	C (DIA)
-CA3	(2.70) .106
-CA6	(6.85) .207

Note:
Additional plating options available on Cable Assemblies, Cable Connectors and Board Connectors. Contact RFGGroup@samtec.com

75 Ω DIE CAST BNC TO 12 GHz

BNC Board Connectors
BNC7T-TH, BNC7T-BH,
BNC7T-BM, BNC7T-EM

Cable Mates:
RF179, RFA6T, RFB6T,
RFC6T, GRF7H-C



BNC7T	GENDER	TYPE	PLATING	ORIENTATION	TERMINATION
	-J = Jack	-P = PCB Mount	-GN = 10 μ" (0.25 μm) Gold contact, 100 μ" (2.54 μm) Nickel Shell	-ST = Straight -RA = Right-angle Bulkhead/Panel Mount	-TH2D = Tall Through-hole Die Cast (-ST only) -BH2D* = Low-Profile Die Cast Bulkhead Through-hole (-RA only) -BM1D* = Low-Profile Die Cast Bulkhead Mixed Technology for (1.60 mm) .062" PCB (-RA only) -BM2D* = Low-Profile Die Cast Bulkhead Mixed Technology for (3.18 mm) .125" PCB (-RA only) -EM1D* = Edge Mount Die Cast Bulkhead/Panel Mount for (1.60 mm) .062" PCB (-ST only) -EM2D* = Edge Mount Die Cast Bulkhead/Panel Mount for (2.40 mm) .093" PCB (-ST only)

Notes:
Contact RFGroup@samtec.com for 12G-SDI PCB mount launch characteristics.

Designed to meet SMPTE 2082 12G-SDI specifications.

Additional plating options available on Board Connectors. Contact RFGroup@samtec.com

75 Ω MACHINED BNC TO 12 GHz

BNC Board Connectors
BNC7T-TH, BNC7T-BH,
BNC7T-EM

Cable Mates:
RF179, RFA6T, RFB6T,
RFC6T, GRF7H-C



BNC7T	GENDER	TYPE	PLATING	ORIENTATION	TERMINATION
	-J = Jack	-P = PCB Mount	-GN = 10 μ" (0.25 μm) Gold contact, 100 μ" (2.54 μm) Nickel Shell	-ST = Straight -RA = Right-angle Bulkhead/Panel Mount	-TH1 = Standard Through-hole (-ST only) -BH1* = Standard Bulkhead Through-hole (-RA only) -EM1* = Edge Mount Bulkhead/Panel Mount for (1.60 mm) .062" PCB (-ST only) -EM2* = Edge Mount Bulkhead/Panel Mount for (2.40 mm) .093" PCB (-ST only)

Notes:
Contact RFGroup@samtec.com for 12G-SDI PCB mount launch characteristics.

Designed to meet SMPTE 2082 12G-SDI specifications.

Additional plating options available on Board Connectors. Contact RFGroup@samtec.com

*Lock washers & knurled nuts supplied with bulkhead/panel mount options

75 Ω DIN 1.0/2.3 TO 12 GHz

DIN Cable Assemblies

RFA6T, RFB6T, RF179, RFB8T, RFC6T, RFC8T



SERIES	END 1 CONNECTOR	END 2 CONNECTOR	OVERALL LENGTH
RFC6T* = 12G-SDI, Belden 4694R Cable RFC8T* = 12G-SDI, Belden 4855R Cable RFA6T = RG 6 Cable RFB6T = Belden 1694A Cable RF179 = RG 179 Cable RFB8T = Belden 1855A Cable	-78SP4 = 75 Ω DIN Straight Plug	ALSO AVAILABLE 75 Ω: HD-BNC™, BNC = RFB6T, RFA6T, RFC6T 75 Ω: BNC, SMB, MCX, MMCX = RF179 75 Ω: HD-BNC™ = RFB8T, RFC8T	-“XXXX” = Overall length in millimeters -0100 (100 mm) 3.94" minimum (RF179) -0300 (300 mm) 11.81" minimum (RFA6T, RFB6T, RFB8T, RFC6T, RFC8T)

*Designed to meet SMPTE 2082 12G-SDI specifications.

DIN Cable Connectors

DIN7A-CA



CONNECTORS FOR INDUSTRY STANDARD CABLES	
DIN7A-PP-C-GF-ST-CA3	RG 179
DIN7A-PP-C-GF-ST-CA6	*RG 6, Belden 1694A or Belden 4694R Cable
DIN7A-PP-C-GF-ST-CA8	*Belden 1855A or Belden 4855R Cable

*Designed to meet SMPTE 2082 12G-SDI specifications.

PP-C = Push Pull Plug Cable
 GF = Plating (10 μ" Gold on center contact, Flash Gold on outer contact, Nickel on Shell)
 ST = Straight

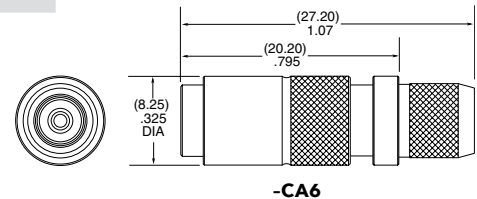

-CA6

Supplied with pins and ferrules. See website for dimensions

DIN Board Connectors

DIN7A-TH, DIN7A-BH

Cable Mates:
 RFA6T, RFB6T, RF179, RFB8T, RFC6T, RFC8T, GRF7H-C



Notes:
 Contact RFGroup@samtec.com for 12G-SDI PCB mount launch characteristics.

Designed to meet SMPTE 2082 12G-SDI specifications.

Additional plating options available on Cable Assemblies, Cable Connectors and Board Connectors. Contact RFGroup@samtec.com

DIN7A	GENDER	TYPE	PLATING	ORIENTATION	TERMINATION
	-J = Jack	-P = PCB Mount	-GF = 10 μ" (0.25 μm) Gold center contact, 3 μ" (0.08 μm) Gold outer contact, (100 μ" (2.54 μm) Nickel body -RA only)	-ST = Straight (-TH1 only) -RA = Right-angle (-BH1 only)	-TH1 = Through-hole (-ST only) -BH1 = Bulkhead Through-hole (-RA only)

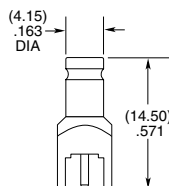
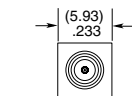

-ST-TH1

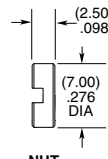
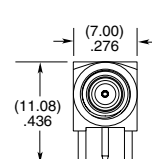

NUT

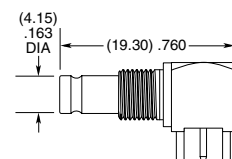

-RA-BH1

ORIGINAL RF SOLUTIONS

SHIELDED TWISTED PAIR SYSTEM

- 100 Ω differential pair
- 28 AWG shielded twisted pair cable assembly
- High reliability BeCu contacts
- 1/4-turn bayonet lock

GANGED MICRO-MINI SYSTEMS

- 50 Ω & 75 Ω board stacking and cable assemblies
- High performance rugged contacts
- Variety of End 2 connectors (GRF1H-C, GRF7H-C Series)

ISORATE® SYSTEMS

- 50 Ω board stacking and cable assemblies
- Isolated signal systems for 90 percent performance of traditional RF at 50 percent of the cost

MINI & MICRO-MINI INTERCONNECTS

- 75 Ω impedance (MMCX7, MCX7 Series)
- Higher extraction forces (MMCXV Series)
- Not intermateable with standard MMCX, MCX

HIGH-CYCLE U.FL CABLE PLUG

- 500 cycle U.FL compatible plug (HMHF1)
- .047" DIA flexible cable (RF047 Series)

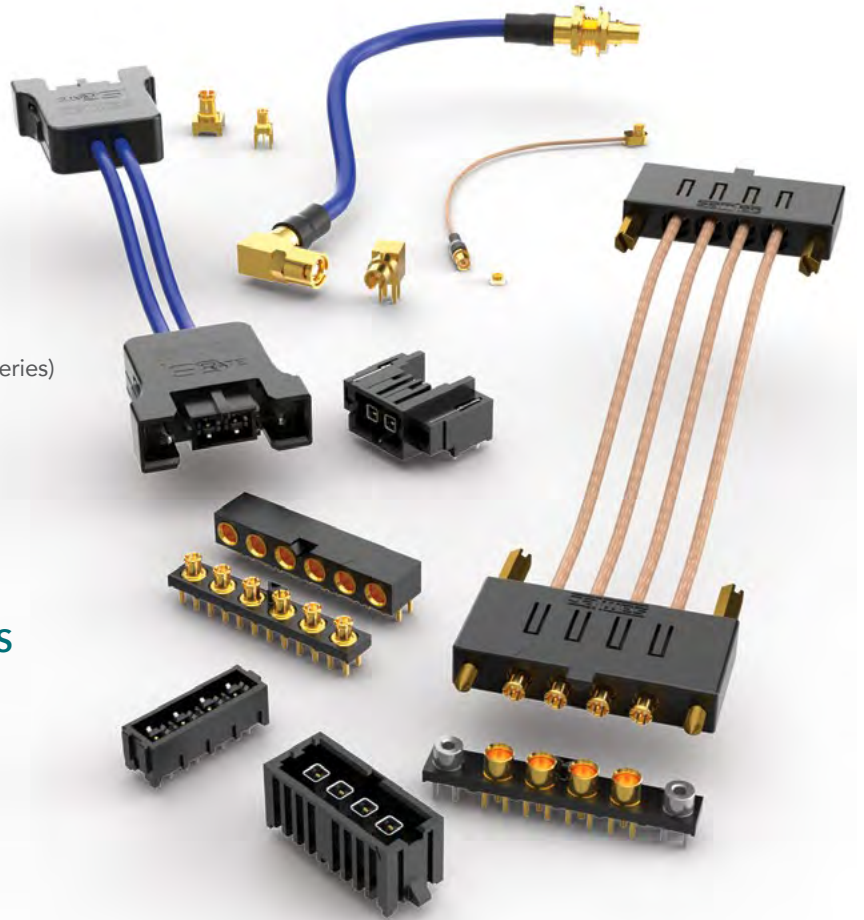

CABLE SOLUTIONS

SERIES	C28S/CJT	GRF1-C/GRF7-C	GRF1H-C/GRF7H-C	RF047	IJ5C/IJ5H
Application	Shielded Twisted Pair	50 Ω & 75 Ω Micro-Mini Ganged	50 & 75 Ω Micro-Mini Hybrid Ganged	50 Ω .047 DIA flexible cable	50 Ω IsoRate®
URL	samtec.com?C28S samtec.com?CJT	samtec.com?GRF1 samtec.com?GRF7-C	samtec.com?GRF1H-C samtec.com?GRF7H-C	samtec.com?RF047	samtec.com?IJ5C samtec.com?IJ5H

BOARD-TO-BOARD SOLUTIONS

SERIES	GRF1-P/GRF1-J	GRF7-P/GRF7-J	MMCX7	MCX7	MMCXV	IJ5/IP5
Application	50 Ω Micro-Mini Ganged	75 Ω Micro-Mini Ganged	75 Ω Mini and Micro-Mini Interconnects		High-Vibration Micro-Mini	50 Ω IsoRate®
URL	samtec.com?GRF1-P samtec.com?GRF1-J	samtec.com?GRF7-P samtec.com?GRF7-J	samtec.com?MMCX7-TH samtec.com?MMCX7-CA	samtec.com?MCX7-SM samtec.com?MCX7-TH samtec.com?MCX7-CA	samtec.com?MMCXV-TH samtec.com?MMCXV-EM samtec.com?MMCXV-CA	samtec.com?IP5 samtec.com?IJ5

CUSTOM RF APPLICATION SPECIFIC SOLUTIONS

EXTREME FLEXIBILITY • QUICK-TURN MODIFICATIONS • CUSTOM DESIGNS

Samtec's fully vertically integrated business model enables the flexibility to quickly and efficiently identify and/or develop innovative, application-specific interconnect solutions to meet a variety of demands in digital/analog systems. Contact RFGroup@samtec.com to discuss your application.

CUSTOMIZED CABLE ASSEMBLIES • EXTREME FLEXIBILITY

- Mix & Match solutions for any application
- Choose any cable connector
- Choose any standard cable



QUICK-TURN MODIFICATIONS & CUSTOMS • STANDARDS & NEW DESIGNS

- Termination types
- Custom tail lengths / designs
- Right-angle height adjustment
- Heat-shrink tubing
- High-frequency applications
- Pick & Place machine designs
- Alternate platings
- Custom labels
- Test & Measurement solutions



TECHNICAL SUPPORT • FULL SYSTEM DESIGN & DEVELOPMENT

- Launch design
- Prototyping
- Fabrication
- Simulations
- Launch optimization support
- Full system test & measurement

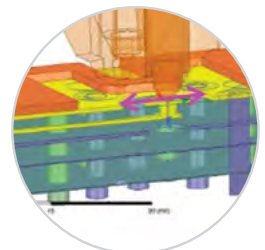
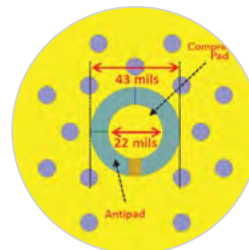
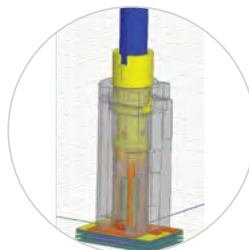

RUGGED TIGER EYE™ & MICRO MATE™ SYSTEMS

HIGH-RELIABILITY • MULTI-FINGER BeCu CONTACT • HIGH MATING CYCLES



172-177

1.00 mm PITCH MICRO MATE™ SYSTEMS

Socket Cable Assemblies/Components (S1SS(T), S1SD(T), T1M, ISS1, ISD1, CC09)	172-175
Single Row Terminal Cable Assemblies/Components (T1SS(T), T1PS(T), IST1, ISP1, TC37)	176
Double Row Terminal Cable Assemblies/Components (T1SD(T), T1PD(T), IDT1, IDP1, TC37)	177

178-181

0.80 mm PITCH TIGER EYE™ SYSTEMS

Micro Pitch Sockets & Terminals (SEM, SEMS, TEM, TEMS)	178-180
Socket Cable Assemblies/Components (SESDT, ISDE, CC396)	181

182-189

.050" (1.27 mm) PITCH TIGER EYE™ SYSTEMS

Standard Pitch Sockets & Terminals (SFM, TFM)	182-184
Cost-Effective Tiger Eye™ Lite Sockets & Terminals (SFC, TFC)	185
Socket Cable Assemblies/Components (SFSS(T), SFSD(T), ISDF, CC03)	186-187
Quad Row Strips (MOLC, FOLC)	188
Flexible Pin Count Tiger Eye™ Sockets (SFMC)	189

190-194

2.00 mm PITCH TIGER EYE™ SYSTEMS

2.00 mm Pitch Sockets & Terminals (S2M, T2M)	190-191
2.00 mm Pitch Cable Assemblies/Components (S2SD(T), T2SD(T), ISD2, CC81)	192-193
2.00 mm Pitch Flex Stack & IDC Cable Socket (SMM)	194

MICROMATE™

RUGGED MICRO CABLE SYSTEMS

(1.00 mm) .0394" PITCH

MAX
3.3
Amps

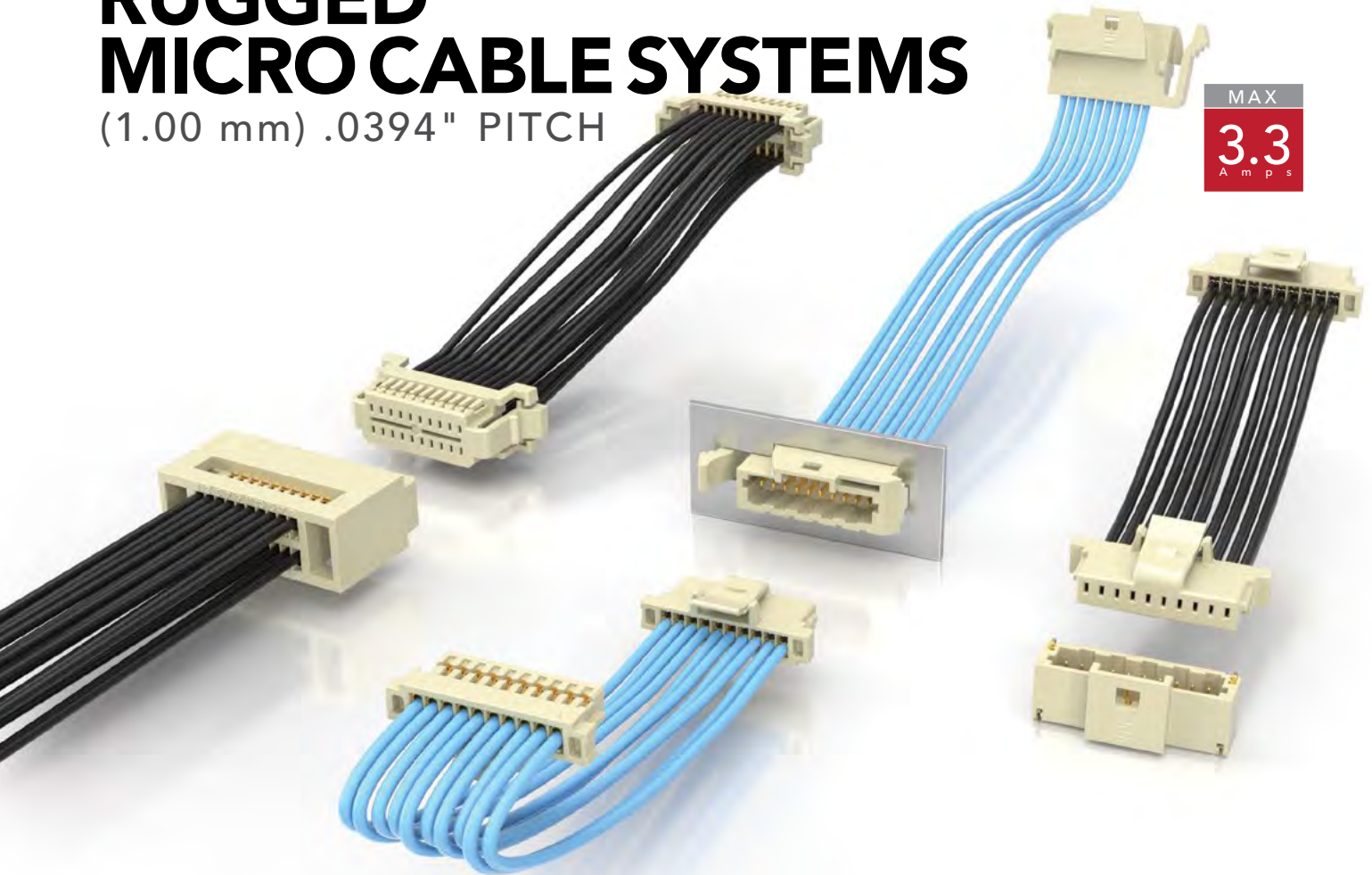

FEATURES & BENEFITS

- Cable-to-cable, panel-to-board and cable-to-board applications
- Extremely small form factors
- 28 and 30 AWG wire options in PVC or Teflon®
- Rugged positive latching for increased retention
- Socket or terminal, single or double row assemblies
- Vertical and right-angle mating headers

Dupont™ Teflon® is a registered trademark of the E.I. du Pont de Nemours and Company or its affiliates.



Dual leaf contact system for a reliable connection

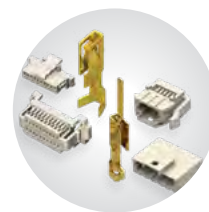

Components and tooling available:
samtec.com/tooling

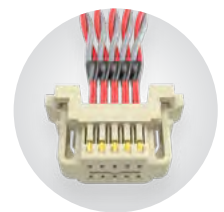

Custom solutions available contact:
asp@samtec.com

KEY SPECIFICATIONS (S1SX(T), T1SX(T) & T1PX(T))

PITCH	INSULATOR MATERIAL	CONTACT MATERIAL	PLATING	OPERATING TEMP RANGE	CURRENT RATING	VOLTAGE RATING
1.00 mm	Black LCP (S1SS(T) without latch) Natural Nylon (S1SS(T) with Latch, S1SD(T), T1XD(T)) Nylon, Light Green (T1XS(T))	Phosphor Bronze	Au or Sn over 50 μ" (1.27 μm) Ni	-10 °C to +85 °C (PVC) -40 °C to +125 °C (Teflon®)	3.3 A per pin (1 pin powered) (Max.)	250 VAC/ 353 VDC

samtec.com/MicroMate

Unless otherwise approved in writing by Samtec, all parts and components are designed and built according to Samtec's specifications which are subject to change without notice.

(1.00 mm) .0394" PITCH • DISCRETE WIRE TERMINAL STRIP

SERIES	NO. OF POSITIONS	PLATING OPTION	ROW OPTION	LATCH	OPTIONS	"X"R
T1M	-02, -03, -05, -07, -10, -15, -20	-F = 3 μ" (0.07 μm) Gold on contact, Matte Tin on tail	-SH = Single Row Horizontal -SV = Single Row Vertical	(Required in callout) -L = Positive Latch	-K = (4.00 mm) .157" DIA Polyimide Film Pick & Place Pad (-SH only) -P = Pick & Place Pad (-SV only)	(Leave blank for Tape & Reel) -FR = Full Reel Tape & Reel (must order max. quantity per reel; contact Samtec for quantity breaks)

T1M-SH/SV Cable Mates: S1SS(T), S1SD(T)

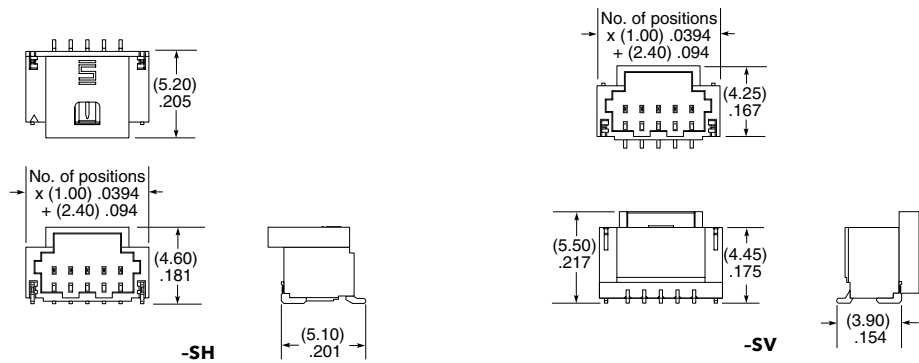
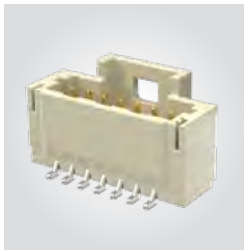

View complete specifications at: samtec.com?T1M

SERIES	NO. OF POSITIONS	PLATING OPTION	ROW OPTION	OPTION	"X"R
T1M	-02, -03, -04, -05, -10, -15, -20 (Per Row)	-GF = 3 μ" (0.07 μm) Gold contact and tail	-DH = Double Row Horizontal -DV = Double Row Vertical	-K = (4.00 mm) .157" DIA Polyimide Film Pick & Place Pad (-DV only)	(Leave blank for Tape & Reel) -FR = Full Reel Tape & Reel (must order max. quantity per reel; contact Samtec for quantity breaks)

T1M-DH/DV Cable Mates: S1SS(T), S1SD(T)

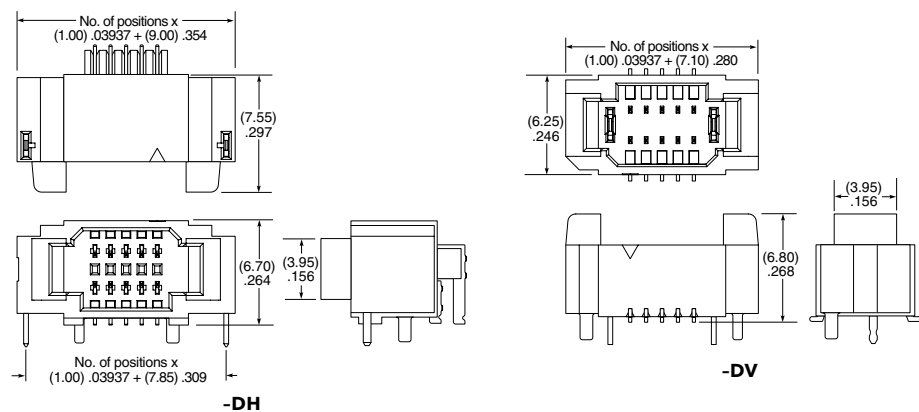
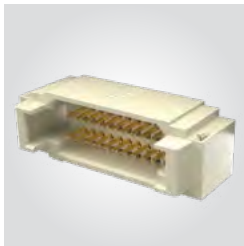

Note:
Some lengths, styles and
options are non-standard,
non-returnable.

View complete specifications at: samtec.com?T1M

(1.00 mm) .0394" PITCH • SINGLE ROW DISCRETE WIRE SOCKET



SERIES	PINS PER ROW	WIRE GAUGE	PLATING OPTION	ASSEMBLED LENGTH	OPTION
S1SS = Single Row PVC Cable	-02, -03, -05, -07, -10 -15, -20 (Standard sizes)	-28 = 28 AWG -28C = 28 AWG Color Coded Cable (S1SS only) -30 = 30 AWG -30C = 30 AWG Color Coded Cable (S1SS only)	-GF = 3 μm (0.07 μm) Gold on contact and tail	-"XX.XX" = Assembled Length in Inches (45.72 mm) 01.80" min.	(Required Callout) -L = Single Ended With Latch -L1 = Double Ended Latch down, straight (Pin 1 to Pin 1) -L3 = Double Ended Latch up, straight (Pin 1 to Pin N) -S = Single Ended No Latch -D-NUS = Double Ended No Latch, "N" up, straight -D-NDS = Double Ended No Latch, "N" down, straight

S1SS(T)

Board Mates:

T1M

Cable Mates:

T1SS(T), T1PS(T)

SPECIFICATIONS

Insulator Material:

Nylon, White (with latch)
Black, LCP (without latch)

Contact Material:

Phosphor Bronze

Plating:

Au over 50 μm (1.27 μm) Ni

Operating Temp Range (S1SS(T)/T1M):

-10 °C to +85 °C (PVC)

-40 °C to +125 °C (Teflon®)

Current Rating (28 AWG):

2.7 A per pin (1 pin powered)

Voltage Rating:

250 VAC/353 VDC

Wire:

28 or 30 AWG

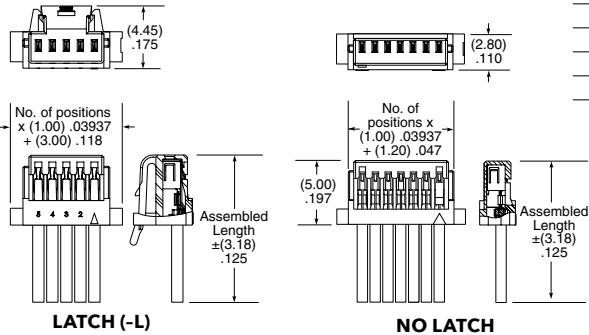

S1SS CABLE COLOR CODING	
PIN	COLOR
1	BROWN
2	RED
3	ORANGE
4	YELLOW
5	GREEN
6	BLUE
7	VIOLET
8	GRAY
9	WHITE
10	BLACK
ETC	REPEAT

*DuPont™ Teflon® is a registered trademark of the E.I. du Pont de Nemours and Company or its affiliates.

Note:
Teflon® cable is intended for crimp only. Contact Samtec for solderable cable applications.

View complete specifications at: samtec.com?S1SS & samtec.com?S1ST

SERIES	NO. OF POSITIONS	LATCH	SERIES	01	PLATING
ISS1 = Single Row Body	-02, -03, -05, -07, -10, -15, -20	(Leave blank for no latch) -L = Positive Latch	CC09R = Contact, Full Reel (30,000 Parts per Reel)		-GF = 3 μm (0.07 μm) Gold contact and tail

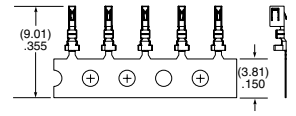
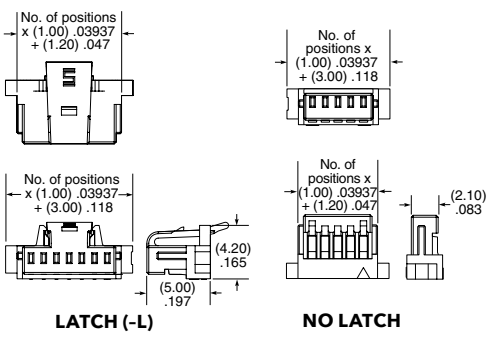

TOOLING

Hand Tool: CAT-HT-309-2830-12	Mini Applicator: CAT-MC-309-2830-XX-01
Clamp for mounting hand tool: CAT-HT-MNT-01	

Note:
Some lengths, styles and options are non-standard, non-returnable.

View complete specifications at: samtec.com?ISS1, samtec.com?CC09R & samtec.com?CC09M

(1.00 mm) .0394" PITCH • DOUBLE ROW DISCRETE WIRE SOCKET

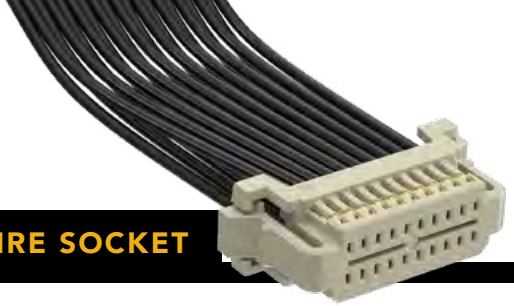

SERIES	PINS PER ROW	WIRE GAUGE	PLATING OPTION	ASSEMBLED LENGTH	WIRING OPTION
S1SD = Double Row PVC Cable	-02, -03 -04, -05, -10, -15, -20 (Standard sizes)	-28 = 28 AWG -30 = 30 AWG	-GF = 3 μ" (0.07 μm) Gold on contact and tail	-"XX.XX" = Assembled Length in Inches (45.72 mm) 01.80" min.	Double Ended Assemblies -L1 = Pin 1 to Pin 1 -L2 = Pin 1 to Pin 2 -L3 = Pin 1 to Pin N -L4 = Pin 1 to Pin N-1 Single Ended Assembly -L = Latching
S1SDT = Double Row Blue *Teflon® Cable					

S1SD(T)
Board Mates:
T1M
Cable Mates:
T1SD(T), T1PD(T)

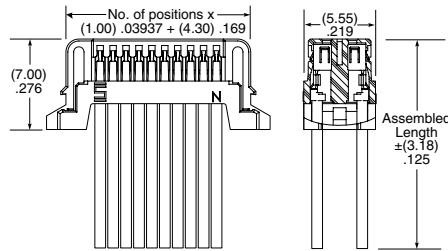
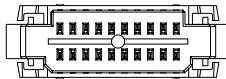



SPECIFICATIONS

Insulator Material:
Natural Nylon
Contact Material:
Phosphor Bronze
Plating:
Au over 50 μ" (1.27 μm) Ni
Operating Temp Range (S1SD(T)/T1M):
-10 °C to +85 °C (PVC)
-40 °C to +125 °C (Teflon®)
Current Rating (28 AWG):
2.3 A per pin
(2 pins powered)
Voltage Rating:
250 VAC/353 VDC
Wire:
28 or 30 AWG

*DuPont™ Teflon® is a registered trademark of the E.I. du Pont de Nemours and Company or its affiliates.

Note:
Teflon® cable is intended for crimp only. Contact Samtec for solderable cable applications.

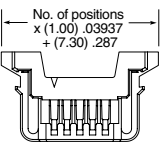
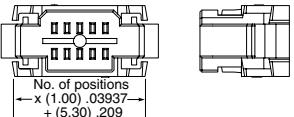
View complete specifications at: samtec.com?S1SD & samtec.com?S1SDT

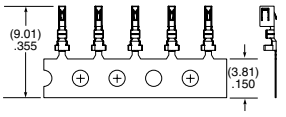
SERIES	NO. OF POSITIONS	SERIES	01	PLATING
ISD1 = Double Row Body	-02, -03, -05, -07, -10, -15, -20 (Per Row)	CC09R = Contact, Full Reel (30,000 Parts per Reel)		-GF = 3 μ" (0.07 μm) Gold contact and tail
		CC09M = Contact, Mini Reel (5,000 Parts per Reel)		
	 			

TOOLING

Hand Tool: CAT-HT-309-2830-12

Clamp for mounting hand tool: CAT-HT-MNT-01

Mini Applicator: CAT-MC-309-2830-XX-01

Note:
Some lengths, styles and options are non-standard, non-returnable.

View complete specifications at: samtec.com?ISD1, samtec.com?CC09R & samtec.com?CC09M

(1.00 mm) .0394" • SINGLE ROW DISCRETE WIRE TERMINAL



SERIES	NO. OF POSITIONS	WIRE GAUGE	PLATING OPTION	ASSEMBLED LENGTH	PANEL OPTION	PINOUT																											
T1SS = Single Row Non-Panel Mount PVC Cable T1PS = Single Row Panel Mount PVC Cable T1SST = Single Row Non-Panel Mount Blue *Teflon® Cable T1PST = Single Row Panel Mount Blue *Teflon® Cable	-02 positions not available with T1PS or T1PST -02 thru -10 (Per Row)	-28 = 28 AWG -28C = 28 AWG Color Coded Cable (T1SS & T1PS only) -30 = 30 AWG -30C = 30 AWG Color Coded Cable (T1SS & T1PS only)	-GF = 3 μ" (0.07 μm) Gold on contact and tail	-"XX.X" = Assembled Length in Inches (45.7 mm) 01.8" min.	(Leave blank for non-panel mount) -A = Fits .033" (0.84 mm), .062" (1.57 mm) and .090" (2.29 mm) Thick Panels	(Leave blank for single ended assembly) -D1 = Double Ended down (Not available with T1PS or T1PST) -D3 = Double Ended up (Not available with T1PS or T1PST) -T1 = Transfer to socket down -T3 = Transfer to socket up																											
				<table border="1"> <thead> <tr> <th colspan="2">-28C, -30C CABLE COLOR CODING</th> </tr> <tr> <th>PIN</th> <th>COLOR</th> </tr> </thead> <tbody> <tr><td>1</td><td>BROWN</td></tr> <tr><td>2</td><td>RED</td></tr> <tr><td>3</td><td>ORANGE</td></tr> <tr><td>4</td><td>YELLOW</td></tr> <tr><td>5</td><td>GREEN</td></tr> <tr><td>6</td><td>BLUE</td></tr> <tr><td>7</td><td>VIOLET</td></tr> <tr><td>8</td><td>GRAY</td></tr> <tr><td>9</td><td>WHITE</td></tr> <tr><td>10</td><td>BLACK</td></tr> <tr><td>ETC</td><td>REPEAT</td></tr> </tbody> </table>		-28C, -30C CABLE COLOR CODING		PIN	COLOR	1	BROWN	2	RED	3	ORANGE	4	YELLOW	5	GREEN	6	BLUE	7	VIOLET	8	GRAY	9	WHITE	10	BLACK	ETC	REPEAT		
-28C, -30C CABLE COLOR CODING																																	
PIN	COLOR																																
1	BROWN																																
2	RED																																
3	ORANGE																																
4	YELLOW																																
5	GREEN																																
6	BLUE																																
7	VIOLET																																
8	GRAY																																
9	WHITE																																
10	BLACK																																
ETC	REPEAT																																
T1SS(T), T1PS(T) Cable Mates: S1SS, S1SST				<p style="text-align: center;">T1SS(T)</p>																													

SPECIFICATIONS

Insulator Material: Nylon, Light Green
Contact Material: Phosphor Bronze
Plating: Au over 50 μ" (1.27 μm) Ni
Operating Temp Range: -10 °C to +80 °C (PVC) -40 °C to +125 °C (Teflon®)
Wire: 28 or 30 AWG

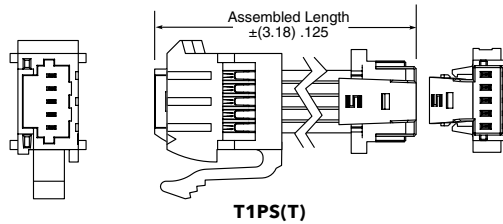

*DuPont™ Teflon® is a registered trademark of the E.I. du Pont de Nemours and Company or its affiliates.

Note: Teflon® cable is intended for crimp only. Contact Samtec for solderable cable applications.

View complete specifications at: samtec.com?T1SS, samtec.com?T1SST, samtec.com?T1PS & samtec.com?T1PST

SERIES	NO. OF POSITIONS	PANEL THICKNESS	SERIES	01	PLATING
IST1 = Single Row Body ISP1 = Single Row Panel Mount Body	-02 thru -10 (IST1 Body) -03 thru -10 (ISP1 Body)	(Leave blank for IST1) -A = Fits 0.84 mm, 1.57 mm & 2.29 mm Thick Panels	TC37R = Contact, Full Reel (25,000 Parts per Reel) TC37M = Contact, Mini Reel (1,000 - 5,000 Parts per Reel)		-GF = 3 μ" (0.07 μm) Gold contact and tail
	<p style="text-align: center;">IST1</p>	<p style="text-align: center;">ISP1</p>			

Note: Some lengths, styles and options are non-standard, non-returnable.

TOOLING

Hand Tool: CAT-HT-1137-2830-12	Mini Applicator: CAT-MC-309-2830-XX-01
--------------------------------	--

View complete specifications at: samtec.com?IST1, samtec.com?ISP1, samtec.com?TC37R & samtec.com?TC37M

(1.00 mm) .0394" PITCH • DOUBLE ROW DISCRETE WIRE TERMINAL



SERIES	NO. OF POSITIONS	WIRE GAUGE	PLATING OPTION	ASSEMBLED LENGTH	PANEL OPTION	PINOUT																										
T1SD = Double Row Non-Panel Mount PVC Cable T1PD = Double Row Panel Mount PVC Cable T1SDT = Double Row Non-Panel Mount Blue *Teflon® Cable T1PDT = Double Row Panel Mount Blue* Teflon® Cable	-02 thru -10 (Per Row)	-28 = 28 AWG -28C = 28 AWG Color Coded Cable (T1SD & T1PD only) -30 = 30 AWG -30C = 30 AWG Color Coded Cable (T1SD & T1PD only)	-GF = 3 μ" (0.07 μm) Gold on contact and tail <table border="1"> <thead> <tr> <th colspan="2">-28C, -30C CABLE COLOR CODING</th> </tr> <tr> <th>PIN</th> <th>COLOR</th> </tr> </thead> <tbody> <tr><td>1</td><td>BROWN</td></tr> <tr><td>2</td><td>RED</td></tr> <tr><td>3</td><td>ORANGE</td></tr> <tr><td>4</td><td>YELLOW</td></tr> <tr><td>5</td><td>GREEN</td></tr> <tr><td>6</td><td>BLUE</td></tr> <tr><td>7</td><td>VIOLET</td></tr> <tr><td>8</td><td>GRAY</td></tr> <tr><td>9</td><td>WHITE</td></tr> <tr><td>10</td><td>BLACK</td></tr> <tr><td>ETC</td><td>REPEAT</td></tr> </tbody> </table>	-28C, -30C CABLE COLOR CODING		PIN	COLOR	1	BROWN	2	RED	3	ORANGE	4	YELLOW	5	GREEN	6	BLUE	7	VIOLET	8	GRAY	9	WHITE	10	BLACK	ETC	REPEAT	"XX.X" = Assembled Length in Inches (45.7 mm) 01.8" min.	(Leave blank for non-panel mount) -A = Fits .033" (0.84 mm), .062" (1.57 mm) and .090" (2.29 mm) Thick Panels	(Leave blank for single ended assembly) -D1 = Double Ended down (Not available with T1PD or T1PDT) -D3 = Double Ended up (Not available with T1PD or T1PDT) -T1 = Transfer to socket down -T3 = Transfer to socket up
-28C, -30C CABLE COLOR CODING																																
PIN	COLOR																															
1	BROWN																															
2	RED																															
3	ORANGE																															
4	YELLOW																															
5	GREEN																															
6	BLUE																															
7	VIOLET																															
8	GRAY																															
9	WHITE																															
10	BLACK																															
ETC	REPEAT																															

T1SD(T), T1PD(T)
Cable Mates:
S1SD, S1SDT

SPECIFICATIONS

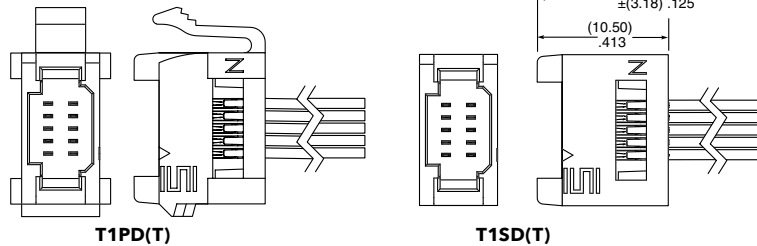

Insulator Material: Nylon, White
Contact Material: Phosphor Bronze
Plating: Au over 50 μ" (1.27 μm) Ni
Operating Temp Range: -10 °C to +80 °C (PVC)
 -40 °C to +125 °C (Teflon®)
Wire: 28 or 30 AWG



*DuPont™ Teflon® is a registered trademark of the E. I. du Pont de Nemours and Company or its affiliates.

Note: Teflon® cable is intended for crimp only. Contact Samtec for solderable cable applications.

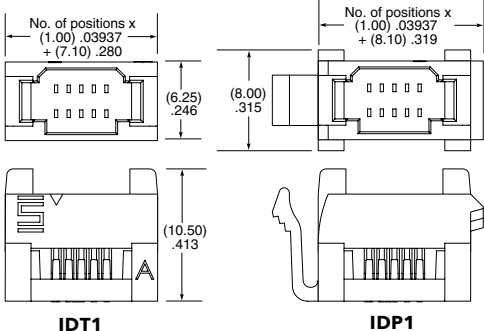
View complete specifications at: samtec.com?T1SD, samtec.com?T1SDT, samtec.com?T1PD & samtec.com?T1PDT

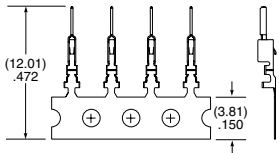
SERIES	NO. OF POSITIONS	PANEL THICKNESS	SERIES	01	PLATING
IDT1 = Double Row Body IDP1 = Double Row Panel Mount Body	-02 thru -10 (per row)	(Leave blank for IDT1) -A = Fits 0.84 mm, 1.57 mm & 2.29 mm Thick Panels	TC37R = Contact, Full Reel (25,000 Parts per Reel) TC37M = Contact, Mini Reel (1,000 - 5,000 Parts per Reel)		-GF = 3 μ" (0.07 μm) Gold contact and tail
					

Note: Some lengths, styles and options are non-standard, non-returnable.

TOOLING

Hand Tool: CAT-HT-1137-2830-12

Mini Applicator: CAT-MC-309-2830-XX-01

View complete specifications at: samtec.com?IDT1, samtec.com?IDP1, samtec.com?TC37R & samtec.com?TC37M



RUGGED TIGER EYE™ SYSTEMS

(0.80 mm) .0315" PITCH



FEATURES & BENEFITS

- High-reliability, multi-finger BeCu contact
- Micro pitch and slim body for space-savings
- 6 mm, 7 mm and 10 mm stack heights
- Locking clip, alignment pins and weld tab ruggedizing features
- Rugged latching system for increased withdrawal force
- Vertical and right-angle mating headers
- Discrete wire assembly available with 32 AWG Teflon® wire; contact asp@samtec.com for custom solutions
- Extended Life Product™ testing available

Dupont™ Teflon® is a registered trademark of the E.I. du Pont de Nemours and Company or its affiliates.

MAX
2.9
A m p s

8
G b p s

TIGER EYE™
CONTACT



Locking for increased unmating force
(Visit samtec.com?SEML for more information)



Components (ISDE/CC396) and tooling available:

samtec.com/tooling



Compatible with UMPT/UMPS for power/signal flexibility

KEY SPECIFICATIONS (SEM/TEM)

PITCH	STACK HEIGHTS	INSULATOR MATERIAL	CONTACT MATERIAL	PLATING	OPERATING TEMP RANGE	CURRENT RATING	VOLTAGE RATING
0.80 mm	6 - 10 mm	Black LCP	BeCu (SEM) Phosphor Bronze (TEM)	Au or Sn over 50 μ" (1.27 μm) Ni	-55 °C to +125 °C	2.9 A per pin (2 pins powered)	235 VAC/330 VDC

samtec.com/080mm-TigerEye

Unless otherwise approved in writing by Samtec, all parts and components are designed and built according to Samtec's specifications which are subject to change without notice.

(0.80 mm) .0315" PITCH • MICRO TIGER EYE™ SOCKET AND HEADER

SERIES	1	NO. PINS PER ROW	02	STACK HEIGHT	PLATING OPTION	D	OPTIONS	OTHER OPTIONS
SEM Socket		05, 10, 15, 20, 25 (SEM, SEMS, TEM, TEMS only)		-03.0 = 6 mm Stack Height (-03.0 required for SEM/SEMS Series)	-FG = Gold Flash		Leave blank for SEMS/TEMS	-K = (3.50 mm) .138" DIA Polyimide film Pick & Place Pad (Required for SEMS)
SEMS Slim Socket		30, 35, 40, 45, 50 (SEM/TEM only) (Standard sizes)		-04.0 = 7 mm Stack Height (TEM/TEMS only)	-G = 10 μ" (0.25 μm) Gold on contact, Gold Flash on tail		-A = Alignment Pin (Not available with -LC or -WT)	= (5.50 mm) .217" DIA Polyimide film Pick & Place Pad (Required for TEMS)
TEM Header				-07.0 = 10 mm Stack Height (TEM/TEMS only)	-H = 30 μ" (0.76 μm) Gold on contact, Gold Flash on tail		-LC = Locking Clip (Not available with -A or -WT) (Manual placement required)	-TR = Tape & Reel (Required for SEMS/TEMS)
TEMS Slim Header							-WT = Weld Tab (Not available with -A or -LC)	-FR = Full Reel Tape & Reel (must order max. quantity per reel; contact Samtec for quantity breaks)

SEM
Board Mates:
TEM

SEMS
Board Mates:
TEMS

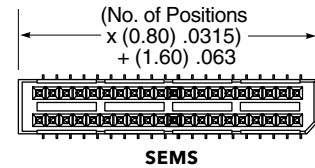
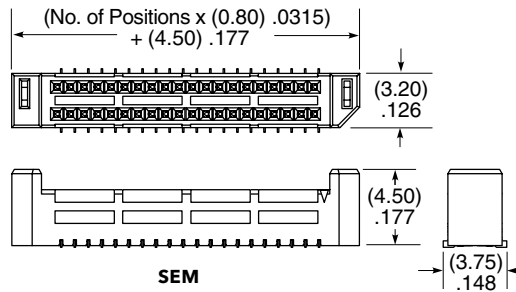

View complete specifications at: samtec.com?SEM & samtec.com?SEMS

TEM
Board Mates:
SEM, SEML

TEMS
Board Mates:
SEMS

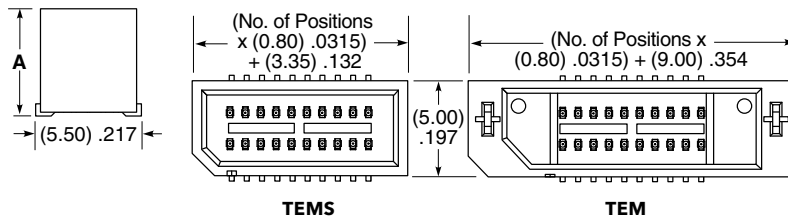

MATED HEIGHTS		
STACK HEIGHT	A	MATED HEIGHT*
-03.0	(5.610) .2209	6 mm
-04.0	(6.610) .2602	7 mm
-07.0	(9.610) .3783	10 mm

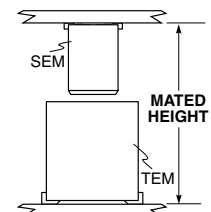

*Processing conditions will affect mated height.

Note:
Some lengths, styles and options are non-standard, non-returnable.

View complete specifications at: samtec.com?TEM & samtec.com?TEMS

(0.80 mm) .0315" PITCH • MICRO TIGER EYE™ HEADER

TEM	1	NO. OF POSITIONS	02	DH1	PLATING OPTION	D	OPTION
		10, 15, 20, 25, 30, 35, 40, 45, 50 (Per Row) (Standard sizes)			-F = Gold Flash on contact, Matte Tin on tail -L = 10 μ" (0.25 μm) Gold on contact, Matte Tin on tail -S = 30 μ" (0.76 μm) Gold on contact, Matte Tin on tail		-A = Alignment Pin

TEM-DH
Board Mates:
SEM, SEML

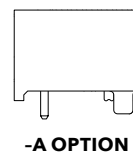
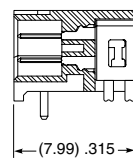
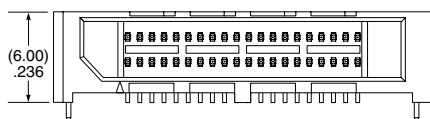
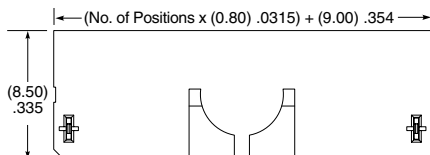

View complete specifications at: samtec.com?TEM

TEM	1	POSITIONS PER ROW	02	3.0	PLATING OPTION	D	L1	OPTIONS
		05, 10, 15, 20 (Standard sizes)			-G = 10 μ" (0.25 μm) Gold on contact, Gold Flash on tail		-L1 = Latching	-K = (5.50 mm) .217" DIA. Polyimide film Pick & Place Pad -TR = Tape & Reel -FR = Full Reel Tape & Reel (must order max. quantity per reel; contact Samtec for quantity breaks)

TEM-L1
Cable Mates:
SESDT

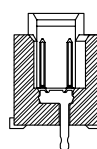
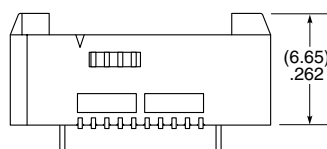
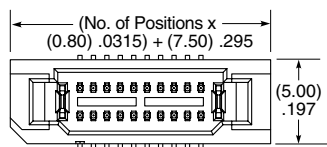

Note:
Some lengths, styles and
options are non-standard,
non-returnable

View complete specifications at: samtec.com?TEM



(0.80 mm) .0315" PITCH • DISCRETE WIRE CABLE ASSEMBLY/COMPONENTS

SES DT	POSITIONS PER ROW	32	PLATING OPTION	ASSEMBLED LENGTH	OPTIONS
---------------	--------------------------	-----------	-----------------------	-------------------------	----------------

= Double Row
Blue *Teflon®
Cable
(32 AWG)

-05, -10, -15, -20
(Standard sizes)

-G
= 10 μ" (0.25 μm)
Gold on contact area,
3 μ" (0.08 μm) Gold on tail

-"XX.X"
= Assembled
Length in Inches
(76.2 mm) 03.0" min.

Double Ended Assemblies

- L1**
= Pin 1 to Pin 1
- L2**
= Pin 1 to Pin 2
- L3**
= Pin 1 to Pin N-1
- L4**
= Pin 1 to Pin N

SES DT
Board Mates:
TEM-L1

SPECIFICATIONS

Insulator Material:
Natural Nylon
Contact Material:
BeCu
Plating:
Au over 50 μ" (1.27 μm) Ni
Wire:
Tinned Copper
Wire Insulation:
FEP
Operating Temp Range:
-55 °C to +125 °C
Current Rating:
1.9 A per pin
(2 pins powered)
Voltage Rating:
200 VAC/280 VDC

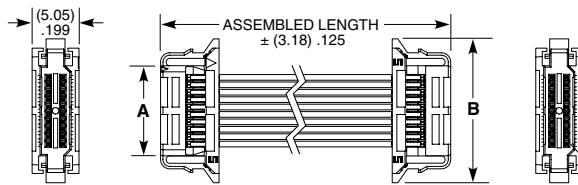

DOUBLE ENDED

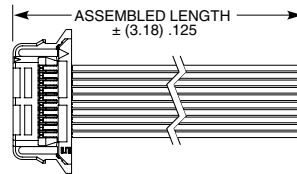

SINGLE ENDED

Single Ended Assembly

- L**
= Latching

NO. OF POSITIONS	A	B
-05	(5.70) .224	(11.50) .453
-10	(9.70) .382	(15.50) .610
-15	(13.70) .539	(19.50) .768
-20	(17.70) .697	(23.50) .925

*DuPont™ Teflon® is a registered trademark of the E.I. du Pont de Nemours and Company or its affiliates.

Note:
Teflon® cable is intended for crimp only. Contact Samtec for solderable cable applications.

View complete specifications at: samtec.com?SES DT

IS DE	POSITIONS PER ROW	D	L	SERIES	WIRE GAUGE	PLATING	REEL OPTIONS
--------------	--------------------------	----------	----------	---------------	-------------------	----------------	---------------------

-05, -10, -15, -20
(Standard sizes)

-D
= Dual Row

-L
= Latch

CC396
= Contact

-3234
= 32 to 34 AWG

-G
= 10 μ" (0.25 μm)
Gold on contact area,
3 μ" (0.08 μm)
Gold on tail

-U
= Micro Reel
(4K Contacts)

-M
= Mini Reel
(15K Contacts)

-R
= Reel
(50K Contacts)

POSITIONS PER ROW	A	B
-05	(9.50) .374	(11.50) .453
-10	(13.50) .531	(15.50) .610
-15	(17.50) .689	(19.50) .768
-20	(21.50) .846	(23.50) .925

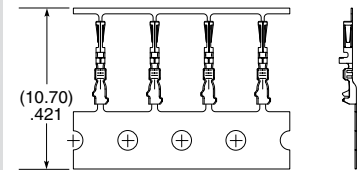
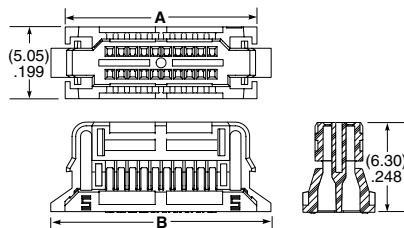

TOOLING

Hand Tool: CAT-HT-396-3232-12

Mini Applicator: CAT-MC-396-3232-XX-03

Note:
Some lengths, styles and options are non-standard, non-returnable

View complete specifications at: samtec.com?IS DE & samtec.com?CC396

RUGGED TIGER EYE™ SYSTEMS

(1.27 mm) .050" PITCH

MAX
3.2
A m p s

8
G b p s

FEATURES & BENEFITS

- Screw down, locking clip, friction latching and weld tab ruggedizing options
- Shrouded, polarized and keyed
- Surface mount or through-hole tails
- High-density, four row design (FOLC/MOLC Series)
- Discrete wire assemblies available in single or double row, 28 and 30 AWG PVC or Teflon® wire; contact asp@samtec.com for custom solutions
- Cable components (ISDF/CC03) and tooling available

Dupont™ Teflon® is a registered trademark of the E.I. du Pont de Nemours and Company or its affiliates.

KEY SPECIFICATIONS (TFM/SFM)

PITCH	STACK HEIGHTS	INSULATOR MATERIAL	CONTACT MATERIAL	PLATING	OPERATING TEMP RANGE	CURRENT RATING	VOLTAGE RATING	MAX CYCLES
1.27 mm	6 to 12 mm	Black LCP	BeCu (SFM) Phosphor Bronze (TFM)	Au or Sn over 50 μ" (1.27 μm) Ni	-55 °C to +125 °C	3.2 A per pin (2 pins powered)	250 VAC	10,000 with 30 μ" (0.76 μm) Au (Call Samtec for E.L.P.™ plating option)

**TIGER™
EYE**
CONTACT



IDC cable assemblies with rugged strain relief (FFSD/FFMD, FFTP/FMTP)

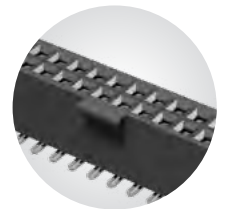

Locking for increased unmating force (SFML/TFML)

(1.27 mm) .050" PITCH • SMT/THROUGH-HOLE SOCKET

SERIES	1	NO. PINS PER ROW	LEAD STYLE	PLATING OPTION	ROW OPTION	OPTIONS
SFM = Standard		03, 04, 06, 08 (SFM only)	(Surface Mount) (Through-hole)	-L = 10 μm (0.25 μm) Gold on contact, Matte Tin on tail (Call Samtec for E.L.P.™ plating option)	-S = Single Row (SFM only)	Specify only -A, -LC or -DS (Not available with -DH, -SH)
SFML = Locking		05, 07, 10, 15, 20, 25, 30, 35, 40, 45, 50 (Standard sizes)	-02 = Tiger Eye™ Contact (BeCu)	-01, -03 = Tiger Eye™ Contact (BeCu)	-D = Double Row	Specify only -K or -P (Lead styles -02, -L2, -T2 only)
			-L2 = Low Insertion Force Tiger Eye™ Contact (BeCu)	-L1, -L3 = Low Insertion Force Tiger Eye™ Contact (BeCu)	-SH = Single Horizontal (05 thru 30 positions only) (SFM only) (Lead style -02 only)	-A = Alignment Pin
			-T2 = Tiger Eye™ LITE Contact (Phosphor Bronze)	-T1 = Tiger Eye™ LITE Contact (Phosphor Bronze)	-DH = Double Horizontal (05 thru 30 positions only) (SFM only) (Lead style -02 only)	-LC = Locking Clip (Manual placement required)
					-DS = Dual Screw Down for (1.60 mm) .062" PCB (05 thru 40 positions only) (Lead styles -01, -02 & -03 only) (Requires -D row option) (Not available with SFML) (Mates with TFM-DS option) (Not available with -A, -LC, -K, -P, -XR)	-K = Polyimide film Pick & Place Pad (Not available with -DH, -SH)
						-P = Plastic Pick & Place Pad (Not available with -DH, -SH)
						Specify -TR or -FR last; Required for -DH & -SH. (Lead styles -02, -L2 & -T2 only)
						-TR = Tape & Reel
						-FR = Full Reel Tape & Reel (must order max. quantity per reel; contact Samtec for quantity breaks)

SFM

Board Mates:
TFM

Cable Mates:
TFSD, TFSS



SFML

Board Mates:
TFML

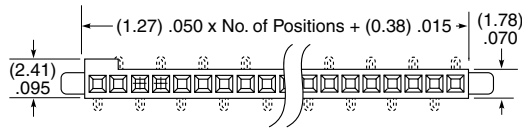

SINGLE ROW

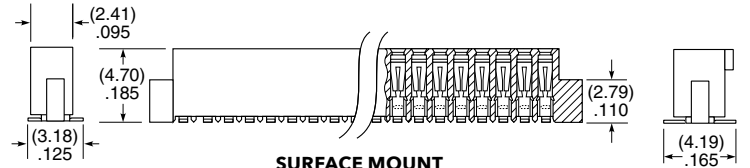

SURFACE MOUNT

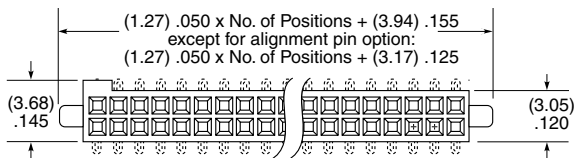

DOUBLE ROW

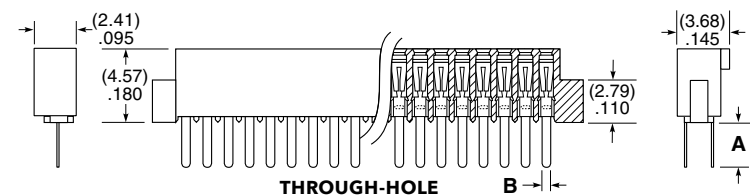

THROUGH-HOLE

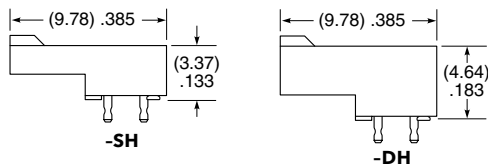

-SH

-DH

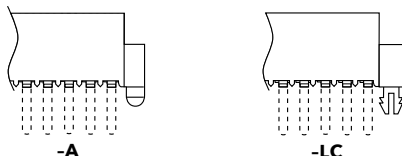

-A

-LC

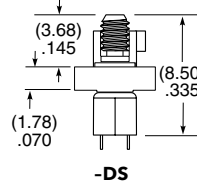

-DS

LEAD STYLE	A	B
-01, -L1, -T1	(3.05) .120	(0.51) .020
-03, -L3	(1.91) .075	(0.41) .016

Note:
Some lengths, styles and options are non-standard, non-returnable.

View complete specifications at: samtec.com?SFM & samtec.com?SFML

SERIES - **1** **NO. PINS PER ROW** - **LEAD STYLE** - **PLATING OPTION** - **ROW OPTION** - **OPTIONS**

TFM
= Standard

TFML
= Locking
(-01 & -02 lead style only)

03, 04, 06, 08
(TFM -01 & -02 only)

05, 07, 10, 15, 20, 25, 30, 35, 40, 45, 50
(Standard sizes)

Specify LEAD STYLE from chart

-L
= 15 μm
(0.38 μm)
Gold on post,
Matte Tin on tail
(Call Samtec
for E.L.P.™
plating option)

-S
= Single Row
(TFM only)

-D
= Double Row

-DH*
= Double Horizontal
Elevated for
(TFM lead style -02 only)
(05 thru 50 positions only)
(-TR or -FR option only available)

Specify only -RA, -RE1 or -RE2

-RA
= Right-angle
(Lead style -01 only)

-RE1
= Right-angle
Elevated for
(1.60 mm) .062" PCB
(Requires TFM lead style -01, -D row and -WT)

-RE2
= Right-angle
Elevated for
(2.36 mm) .093" PCB
(Requires TFM lead style -01, -D row and -WT)

Specify only -A, -LC, -DS or -WT
Not available with -RA, -RE1 and -RE2 unless otherwise noted.

-A
= Alignment Pin

-LC
= Locking Clip
(Manual Placement required)

-DS
= Dual Screw Down
for (1.60 mm) .062" PCB
(05, 07, 10, 15, 20, 25, 30, 35, 40 positions only)
(TFM lead styles -01 and -02 only)
(Requires -D row option)
(Mates with SFM-DS option and SFSD/SFSDT -SS and -DS option only)
(Not available with -A, -LC, -WT, -K, -P, -XR)

-WT
= Weld Tab
(TFM lead styles -01 and -02 only)
(Required callout for -RE1 & -RE2)
(Mates to SFSS/SFSD -SR and -DR option only)
(05, 07, 10, 15, 20, 25, 30, 35, 40, 45, 50 positions only)

SMT lead styles only
Specify only -K or -P

-K
= Polyimide Film Pick & Place Pad

-P
= Plastic Pick & Place Pad
(5 positions min.)
(Not available with 5 position with -WT)

Specify -TR or -FR last
(Not available with -DS)

-TR
= Tape & Reel

-FR
= Full Reel
Tape & Reel
(must order max. quantity per reel; contact Samtec for quantity breaks)

TFM

Board Mates:
SFM, SFMC
Cable Mates:
SFSD



TFML

Board Mates:
SFML

MATED HEIGHTS*		
LEAD STYLE (SMT)		MATED HEIGHT*
TFM	SFM	
-02		(6.35) .250
-12	-02	(8.13) .320
-22		(9.91) .390
-32		(11.81) .465
LEAD STYLE (T/H)		MATED HEIGHT*
TFM	SFM	
-01		(5.97) .235
-03		(5.97) .235
-11		(7.75) .305
-13	-01	(7.75) .305
-21		(9.53) .375
-23		(9.53) .375
-31		(11.43) .450

*Processing conditions will affect mated height.

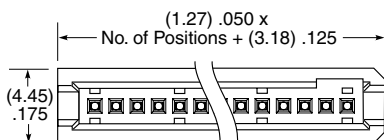

SINGLE ROW

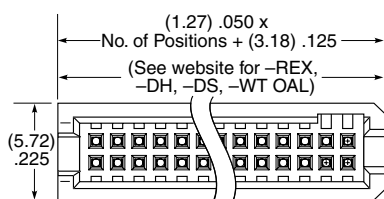

DOUBLE ROW

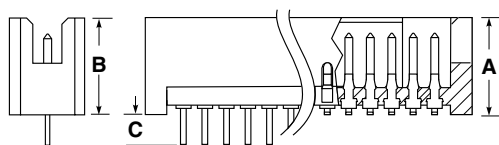

THROUGH-HOLE SURFACE MOUNT

LEAD STYLE (SMT)	A
-02	(5.72) .225
-12*	(7.49) .295
-22*	(9.27) .365
-32*	(11.18) .440

* N/A with 07, -DH or -S row option

LEAD STYLE (T/H)	B	C
-01	(5.59) .220	(1.97) .078
-03*	(5.59) .220	(2.77) .109
-11*	(7.37) .290	(1.97) .078
-13*	(7.37) .290	(2.77) .109
-21*	(9.14) .360	(1.97) .078
-23*	(9.14) .360	(2.77) .109
-31*	(11.05) .435	(1.97) .078

* Not Available with 07 or -S row option

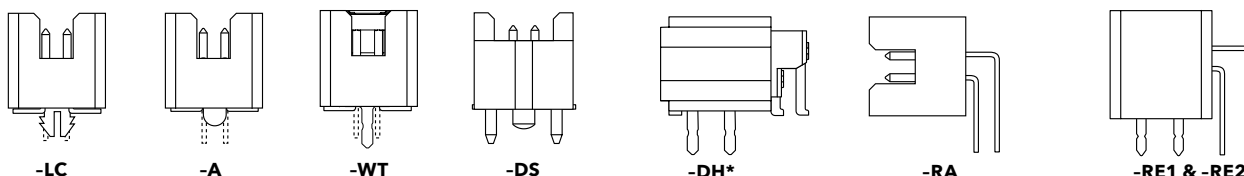

Note:
Some lengths, styles and options are non-standard, non-returnable.

View complete specifications at: samtec.com?TFM & samtec.com?TFML

(1.27 mm) .050" PITCH • COST-EFFECTIVE HEADER/SOCKET

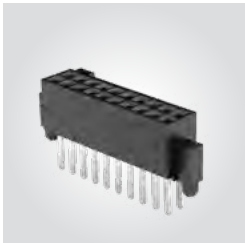
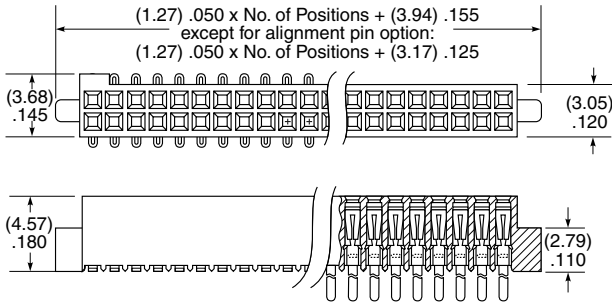
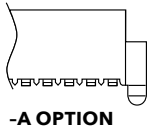
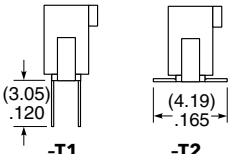
SFC	1	NO. PINS PER ROW	LEAD STYLE	PLATING OPTION	D	OPTIONS
		04, 05, 10, 15, 20, 25, 30, 35, 40, 45, 50 (Standard sizes)	-T1 = Through-hole Tiger Eye™ LITE -T2 = Surface Mount Tiger Eye™ LITE	-F = Gold flash on contact, Matte Tin on tail -L = 10 μ" (0.25 μm) Gold on contact, Matte Tin on tail		-A = Alignment Pin -K = (4.00 mm) .157" DIA Polyimide film Pick & Place Pad -TR = Tape & Reel (-T2 only) -FR = Full Reel Tape & Reel (must order max. quantity per reel; contact Samtec for quantity breaks) (-T2 only)
SFC Board Mates: TFC Cable Mates: TFS, TFSDT			 <p>(1.27) .050 x No. of Positions + (3.94) .155 except for alignment pin option: (1.27) .050 x No. of Positions + (3.17) .125</p> <p>(3.68) .145 (3.05) .120</p> <p>(4.57) .180 (2.79) .110</p>			 -A OPTION  -T1 -T2

View complete specifications at: samtec.com?SFC

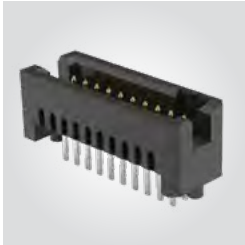
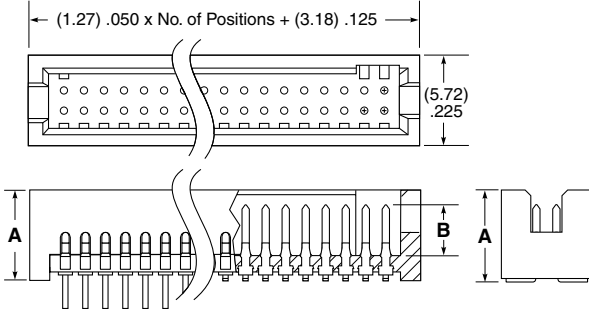
TFC	1	NO. PINS PER ROW	LEAD STYLE	PLATING OPTION	D	OPTIONS																														
		03, 04, 06, 08 (Lead Style -01 & -02 only) 05, 07, 10, 15, 20, 25, 30, 35, 40, 45, 50 (Standard sizes)	-X1 = Through-hole -X2 = Surface Mount	-F = Gold flash on post, Matte Tin on tail -L = 15 μ" (0.38 μm) Gold on post, Matte Tin on tail		-RA = Right-angle (-01 only) -A = Alignment Pin -LC = Locking Clip (Manual Placement required) (not available with -RA) -K = (6.75 mm) .266" DIA Polyimide film Pick & Place Pad (not available with -RA) -P = Plastic Pick & Place Pad (5 positions min.) (not available with -RA) -TR = Tape & Reel (-X2 only) (not available with -RA) -FR = Full Reel Tape & Reel (must order max. quantity per reel; contact Samtec for quantity breaks) (-X2 only) (not available with -RA)																														
TFC Board Mates: SFC Cable Mates: SFS, SFSDT			 <p>(1.27) .050 x No. of Positions + (3.18) .125</p> <p>(5.72) .225</p> <p>A B A</p>			<table border="1"> <thead> <tr> <th>SMT LEAD STYLE</th> <th>A</th> <th>B</th> <th>TH LEAD STYLE</th> <th>A</th> <th>B</th> </tr> </thead> <tbody> <tr> <td>-02</td> <td>(5.72) .225</td> <td>(3.38) .133</td> <td>-01</td> <td>(5.59) .220</td> <td>(3.38) .133</td> </tr> <tr> <td>-12</td> <td>(7.49) .295</td> <td></td> <td>-11</td> <td>(7.37) .290</td> <td></td> </tr> <tr> <td>-22</td> <td>(9.27) .365</td> <td>(3.30) .130</td> <td>-21</td> <td>(9.14) .360</td> <td>(3.30) .130</td> </tr> <tr> <td>-32</td> <td>(11.18) .440</td> <td></td> <td>-31</td> <td>(11.05) .435</td> <td></td> </tr> </tbody> </table>	SMT LEAD STYLE	A	B	TH LEAD STYLE	A	B	-02	(5.72) .225	(3.38) .133	-01	(5.59) .220	(3.38) .133	-12	(7.49) .295		-11	(7.37) .290		-22	(9.27) .365	(3.30) .130	-21	(9.14) .360	(3.30) .130	-32	(11.18) .440		-31	(11.05) .435	
SMT LEAD STYLE	A	B	TH LEAD STYLE	A	B																															
-02	(5.72) .225	(3.38) .133	-01	(5.59) .220	(3.38) .133																															
-12	(7.49) .295		-11	(7.37) .290																																
-22	(9.27) .365	(3.30) .130	-21	(9.14) .360	(3.30) .130																															
-32	(11.18) .440		-31	(11.05) .435																																

View complete specifications at: samtec.com?TFC

Note:
Some lengths, styles and options are non-standard, non-returnable.

(1.27 mm) .050" PITCH • DISCRETE WIRE ASSEMBLY/COMPONENTS

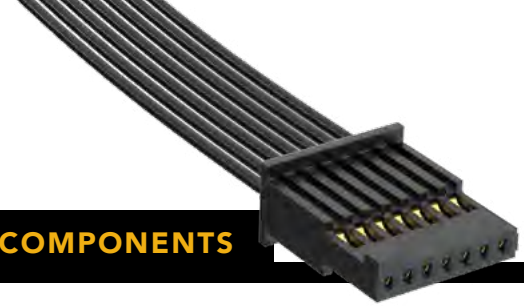

SERIES	POSITIONS PER ROW	WIRE GAUGE	PLATING OPTION	ASSEMBLED LENGTH	END OPTION	END 2 OPTION
SFSS = Single Row PVC Cable SFSS(T) = Single Row Blue *Teflon® Cable	-03, -04, -05, -07, -10, -15, -20, -25, -40, -50 (Standard sizes)	-28 = 28 AWG -28C = Color Coded Cable (SFSS only) -30 = 30 AWG	-G = 10 μ" (0.25 μm) Gold on contact, Gold Flash on balance	-"XX.XX" = Assembled Length in Inches (76.20 mm) 03.00" min. for -S end option 03.25" min. for -D end option	-S = Single Ended -D = Double Ended -SR = Single Ended Retention Latch (TFM-WT option required for mating) -DR = Double Ended Retention Latch (TFM-WT option required for mating)	Requires -D or -DR (End 1 Notch Up) -NUS = Notch up, straight (Pin 1 to Pin N) -NDS = Notch down, straight (Pin 1 to Pin 1)

SFSS(T) Board Mates:
TFM, TFC
(-SR & -DR requires -WT option)

-28C CABLE COLOR CODING	
PIN	COLOR
1	BROWN
2	RED
3	ORANGE
4	YELLOW
5	GREEN
6	VIOLET
7	GRAY
8	WHITE
9	BLACK
10	BLUE
ETC	REPEAT

SPECIFICATIONS

Insulator Material: Black LCP
Contact Material: BeCu
Plating: Au over 50 μ" (1.27 μm) Ni
Current Rating: 2.9 A per pin (2 pins powered)
Operating Temp Range: -10 °C to +80 °C (PVC)
 -40 °C to +125 °C (*Teflon®)
Voltage Rating: 275 VAC (PVC)
 235 VAC (*Teflon®)
Wire: 28 or 30 AWG

*DuPont™ Teflon® is a registered trademark of the E.I. du Pont de Nemours and Company or its affiliates.

Notes: Teflon® cable is intended for crimp only. Contact Samtec for solderable cable applications.

For wiring option information refer to drawings on web.

View complete specifications at: samtec.com?SFSS & samtec.com?SFSST

ISDF	POSITIONS PER ROW	ROW OPTION	OPTION	SERIES	WIRE GAUGE	01	PLATING
	-03, -04, -05, -07, -10, -15, -20, -25, -40, -50 (Standard sizes)	-S = Single Row	-M = Metal Retention Latch	CC03R = Contact, Full Reel (35,000 Parts per Reel) CC03M = Contact, Mini Reel (1,000 - 5,000 Parts per Reel)	-2830 = 28 to 30 AWG		-GF = Gold flash contact -G = 10 μ" (0.25 μm) Gold on contact

TOOLING

Hand Tool: CAT-HT-203-2830-12	Mini Applicator: CAT-MC-203-2830-XX-01
Clamp for mounting hand tool: CAT-HT-MNT-01	Extraction Tool: CAT-EX-169-01

Note: Some lengths, styles and options are non-standard, non-returnable.

View complete specifications at: samtec.com?ISDF, samtec.com?CC03R & samtec.com?CC03M



(1.27 mm) .050" PITCH • DISCRETE WIRE ASSEMBLY/COMPONENTS

SERIES	POSITIONS PER ROW	WIRE GAUGE	PLATING OPTION	ASSEMBLED LENGTH	END OPTION	END 2 OPTION
SFSD = Double Row PVC Cable SFSDT = Double Row Blue *Teflon® Cable	-03, -04, -05, -07, -10, -15, -20, -25, -40, -50 (Standard sizes)	-28 = 28 AWG -28C = Color Coded Cable (SFSD only) -30 = 30 AWG	-G = 10 μ" (0.25 μm) Gold on contact, Gold Flash on balance	-"XX.XX" = Assembled Length in Inches (76.20 mm) 03.00" min. for -S end option (82.60 mm) 03.25" min. for -D end option	-S = Single Ended -D = Double Ended For -(X) specify "S" for single ended and "D" for double ended. -(X)R = Retention Latch (TFM-WT option required for mating) -(X)S = Screw Down (Not available in -03, -04 & -50 positions) (Mates with TFM-DS option)	Requires -D, -DS, -DR (End 1 Notch Up) -NUS = Notch up, straight (Pin 1 to Pin N-1) -NDS = Notch down, straight (Pin 1 to Pin 2) -NUX = Notch up, crossed (Pin 1 to Pin N) -NDX = Notch down, crossed (Pin 1 to Pin 1)

SFSD(T) Board Mates:
TFM, TFC
(-SR & -DR requires -WT option)

-28C CABLE COLOR CODING	
PIN	COLOR
1	BROWN
2	RED
3	ORANGE
4	YELLOW
5	GREEN
6	VIOLET
7	GRAY
8	WHITE
9	BLACK
10	BLUE
ETC	REPEAT

SPECIFICATIONS

Insulator Material: Black LCP
Contact Material: BeCu
Plating: Au over 50 μ" (1.27 μm) Ni
Current Rating: 2.9 A per pin (2 pins powered)
Operating Temp Range: -10 °C to +80 °C (PVC), -40 °C to +125 °C (*Teflon®)
Voltage Rating: 275 VAC (PVC), 235 VAC (*Teflon®)
Wire: 28 or 30 AWG

*DuPont™ Teflon® is a registered trademark of the E.I. du Pont de Nemours and Company or its affiliates.

Notes: Teflon® cable is intended for crimp only. Contact Samtec for solderable cable applications.

For wiring option information refer to drawings on web.

View complete specifications at: samtec.com?SFSD & samtec.com?SFSdT

ISDF	POSITIONS PER ROW	ROW OPTION	OPTION	SERIES	WIRE GAUGE	01	PLATING
	-03, -04, -05, -07, -10, -15, -20, -25, -40, -50 (Standard sizes)	-D = Double Row	-M = Metal Retention Latch -S = Screw Down	CC03R = Contact, Full Reel (35,000 Parts per Reel) CC03M = Contact, Mini Reel (1,000 - 5,000 Parts per Reel)	-2830 = 28 to 30 AWG		-GF = Gold flash contact -G = 10 μ" (0.25 μm) Gold on contact

TOOLING

Hand Tool: CAT-HT-203-2830-12	Mini Applicator: CAT-MC-203-2830-XX-01
Clamp for mounting hand tool: CAT-HT-MNT-01	Extraction Tool: CAT-EX-169-01

Note: Some lengths, styles and options are non-standard, non-returnable.

View complete specifications at: samtec.com?ISDF, samtec.com?CC03R & samtec.com?CC03M

QUAD ROW TERMINAL/SOCKET

(1.27 mm) .050" PITCH • FOLC/MOLC SERIES

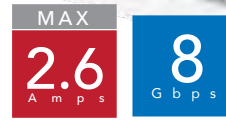

FOLC
Board Mates:
MOLC

MOLC
Board Mates:
FOLC

FOLC	1	NO. PINS PER ROW	LEAD STYLE	PLATING OPTION	Q	OPTION
		20, 25, 30, 35, 40, 45, 50 (Standard sizes)	-01 & -04 = Through-hole -M1 & -M2 = Mixed Technology -L1 & -L4 = Low Insertion Force Through-hole	-L = 10 μ" (0.25 μm) Gold on contact, Matte Tin on tail		-LC = Locking Clip (Manual placement required)

SPECIFICATIONS

Insulator Material:
Black Liquid Crystal Polymer
Contact Material (FOLC):
BeCu
Terminal Material (MOLC):
Phosphor Bronze
Plating:
Au or Sn over
50 μ" (1.27 μm) Ni
Current Rating:
2.6 A per pin
(4 pins powered)
Operating Temp Range:
-55 °C to +125 °C
Voltage Rating:
165 VAC/230 VDC
Insertion Depth (FOLC):
(3.30 mm) .130" to
(4.06 mm) .160"
Normal Force (FOLC):
Standard = 70 grams
(0.69 N) avg.
LIF = 40 grams
(0.39 N) avg.
Max Cycles (FOLC):
100

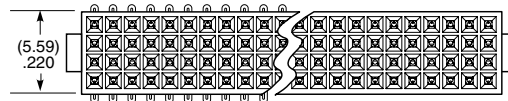

LEAD STYLE	C
-01, -M1	(1.91) .075
-04, -M2	(3.04) .120

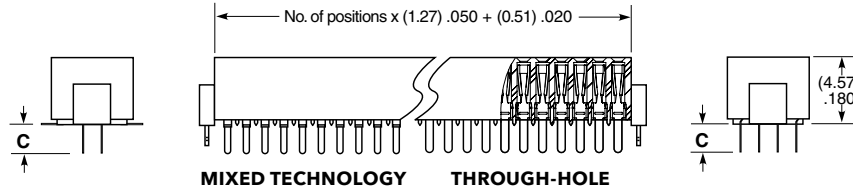

View complete specifications at: samtec.com?FOLC

PROCESSING

Lead-Free Solderable:
Yes
SMT Lead Coplanarity (MOLC):
(0.10 mm) .004" max (20-25)
(0.15 mm) .006" max (30-50)*
*(.004" stencil solution may be available; contact IPG@samtec.com)

MOLC	1	NO. PINS PER ROW	LEAD STYLE	PLATING OPTION	Q	OPTION
		20, 25, 30, 35, 40, 45, 50 (Standard sizes)	-'X'1 = Through-hole (Specify from chart) -02 = Surface Mount -M1 = Mixed Technology	-L = 10 μ" (0.25 μm) Gold on post, Matte Tin on tail		-LC = Locking Clip (Manual placement required) -P = Pick & Place Pad (-02 only) -TR = Tape & Reel (-02 only) -FR = Full Reel Tape & Reel (must order max. quantity per reel; contact Samtec for quantity breaks) (-02 only)

APPLICATIONS

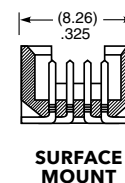
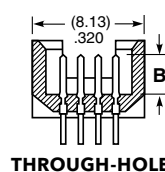
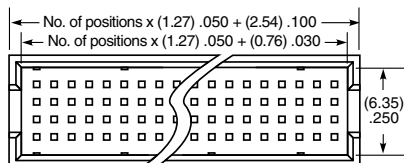
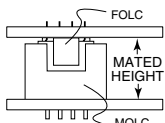

LEAD STYLE		MATED HEIGHT*
MOLC	FOLC	
-01		(5.97) .235
-11	-01	(7.75) .305
-31		(11.43) .450

*Processing conditions will affect mated height.

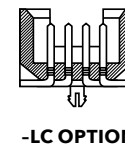
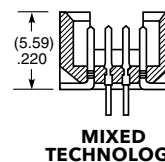
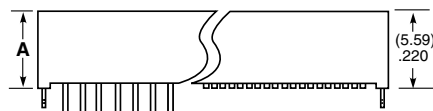

LEAD STYLE	A	B
-01	(5.59) .220	(3.38) .133
-11	(7.34) .289	(3.66) .144
-31	(11.05) .435	

Note:
Some lengths, styles and options are non-standard, non-returnable.

View complete specifications at: samtec.com?MOLC

FLEXIBLE PIN COUNT TIGER EYE™ SOCKET

(1.27 mm) .050" PITCH • SFMC SERIES

MAX
2.9
A m p s

8
G b p s

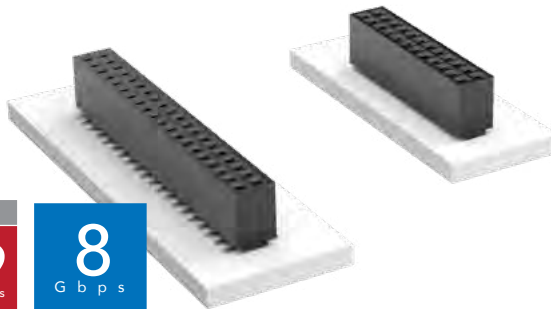

SFMC Board Mates: TFM

Cable Mates:
FMTP, FFMD*

*Note: Standard FFMD callout will not mate with FLE, SFMC. Must use gold plated callouts. (See drawing on web.)

SFMC	1	NO. PINS PER ROW	LEAD STYLE	PLATING OPTION	D	OPTIONS
------	---	------------------	------------	----------------	---	---------

02 thru 50

-01, -03
= Through-hole

-L1, -L3
= Low Insertion Force Through-hole

-02
= Surface Mount

-L2
= Low Insertion Force Surface Mount

-T1
= Through-hole Tiger Eye™ LITE

-T2
= Surface Mount Tiger Eye™ LITE

-L
= 10 μ" (0.25 μm) Gold on contact, Matte Tin on tail

-K
= (4.00 mm) .157" DIA Polyimide film Pick & Place Pad (4 positions min.)

-P
= Plastic Pick & Place Pad (5 positions min.)

-TR
= Tape & Reel

-FR
= Full Reel Tape & Reel (must order max. quantity per reel; contact Samtec for quantity breaks)

SPECIFICATIONS

Insulator Material:
Black Liquid Crystal Polymer

Contact Material:
Tiger Eye™ = BeCu
Tiger Eye™ LITE = Phosphor Bronze

Plating:
Au or Sn over 50 μ" (1.27 μm) Ni

Current Rating:
2.9 A per pin (2 pins powered)

Voltage Rating:
220 VAC/310 VDC

Operating Temp Range:
-55 °C to +125 °C

Insertion Depth:
(3.05 mm) .120" to (4.06 mm) .160"

Normal Force:
Standard = 132 g (1.29 N) avg.
LIF = 90 g (0.88 N) avg.

Max Cycles:
10,000 with 30 μ" (0.76 μm) Au

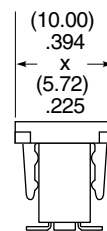
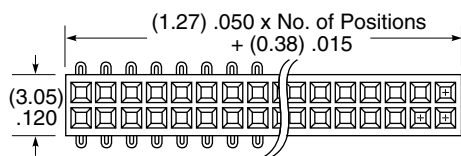

-P OPTION

PROCESSING

Lead-Free Solderable:
Yes

SMT Lead Coplanarity:
(0.10 mm) .004" max (02-26)
(0.15 mm) .006" max (27-50)*
*(.004" stencil solution may be available; contact IPG@samtec.com)

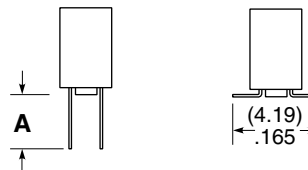
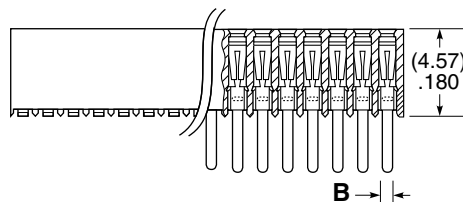

ALSO AVAILABLE

Other plating (MOQ Required)

LEAD STYLE	A	B
-01, -L1, -T1	(3.05) .120	(0.51) .020
-03, -L3	(1.91) .075	(0.41) .016

Note:
Some lengths, styles and options are non-standard, non-returnable.

View complete specifications at: samtec.com?SFMC

RUGGED TIGER EYE™ SYSTEMS

(2.00 mm) .0787" PITCH

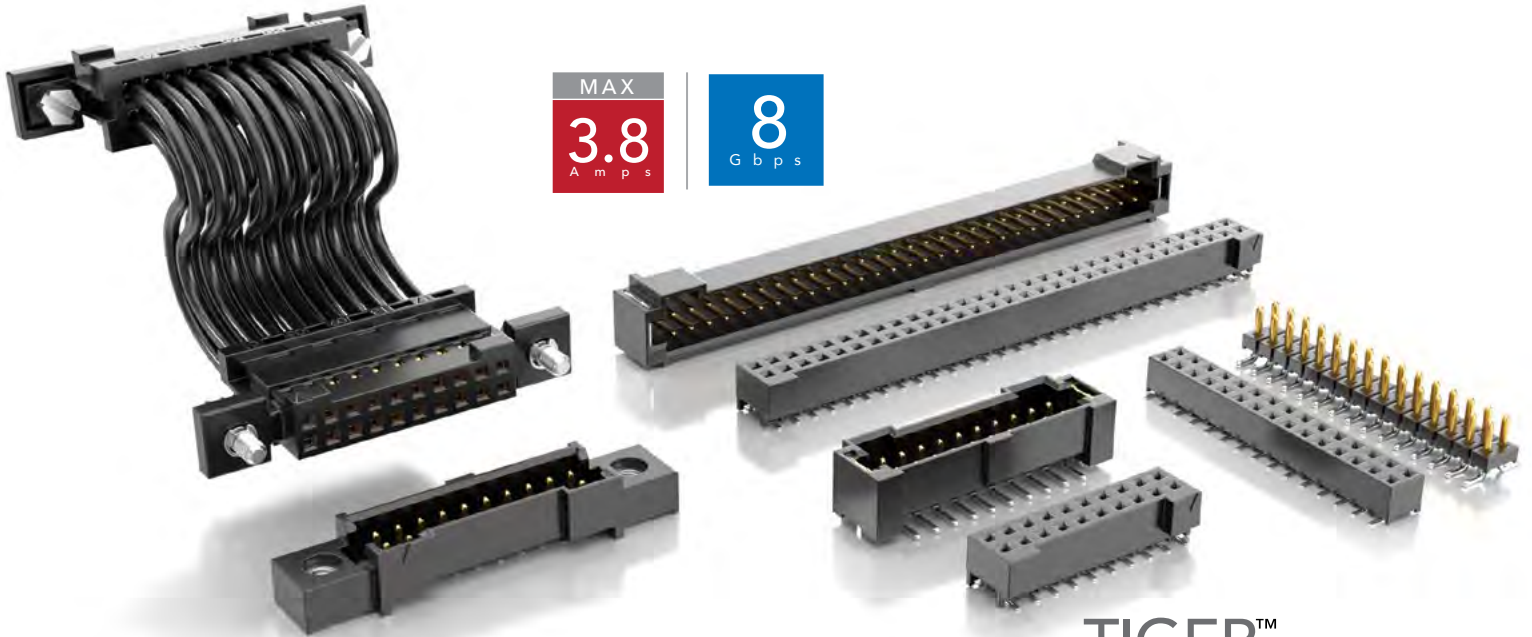

FEATURES & BENEFITS

- Rugged Tiger Eye™ contact system for high-reliability
- Wide range of stack heights (SMM/TMM Series)
- Right-angle mating headers available
- Optional metal latching, screw downs, weld tabs and locking clips
- Surface mount or through-hole
- Discrete wire assemblies available in 24-30 AWG PVC or Teflon® wire; contact_asp@samtec.com for custom solutions



Optional strain relief and variety of wiring options



Components (ISD2/CC81) & tooling available: samtec.com/tooling

KEY SPECIFICATIONS (S2M/T2M)

PITCH	STACK HEIGHTS	TOTAL PINS	INSULATOR MATERIAL	CONTACT MATERIAL	PLATING	OPERATING TEMP RANGE	CURRENT RATING	MAX CYCLES
2.00 mm	6 & 7 mm	10 - 60	Black LCP	BeCu (S2M) Phosphor Bronze (T2M)	Au or Sn over 50 μ" (1.27 μm) Ni	-55 °C to +125 °C	3.8 A (T2M) 2.6 A (S2M (2 pins powered)	100 with 10 μ" (0.25 μm) Au

(2.00 mm) .0787" PITCH • HIGH-RELIABILITY CABLE INTERCONNECTS

SERIES	1	NO. OF POSITIONS	LEAD STYLE	PLATING OPTION	D	OPTIONS	PACKAGING
S2M Socket		05, 07, 10, 15, 20, 25, 30 (Per Row)	-01 = Through-hole -02 = Surface Mount	-F = Gold flash on contact, Matte Tin on tail -L = 10 μ" (0.25 μm) Gold on contact, Matte Tin on tail		-K = (5.50 mm) .217" DIA Polyimide film Pick & Place Pad (-02 only) -LC = Locking Clip (Manual placement required) (-02 only) -DS = Screw Down (N/A with -LC) (mates with -T2M-DS)	Leave blank for tube packaging -TR = Tape & Reel (-02 only) -FR = Full Reel Tape & Reel (must order max. quantity per reel; contact Samtec for quantity breaks) (-02 only)

S2M
Board Mates:
T2M
Cable Mates:
T2SD



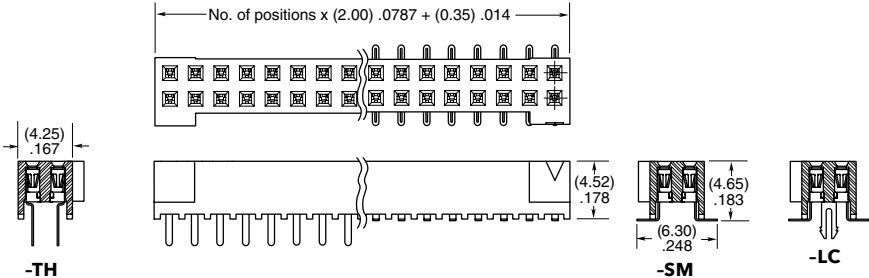

View complete specifications at: samtec.com?S2M

SERIES	1	NO. OF POSITIONS	01	PLATING OPTION	D	TAIL OPTION	OTHER OPTIONS	PACKAGING
T2M Header		05, 07, 10, 15, 20, 25, 30 (Per Row)		-L = 10 μ" (0.25 μm) Gold on contact, Matte Tin on tail		-TH = Through-hole -RA = Right-angle -SM = Surface Mount	-WT = Weld Tab (S2SD & S2SDT, -SR/-DR required mate) -DS = Screw Down (N/A with -RA) (mates with -S2M-DS, S2SD/S2SDT -SS/-DS option) -K = (7.50 mm) .295" DIA Polyimide film Pick & Place Pad (-SM only)	Leave blank for tube packaging -TR = Tape & Reel (-SM only) -FR = Full Reel Tape & Reel (must order max. quantity per reel; contact Samtec for quantity breaks) (-SM only)

T2M
Board Mates:
S2M
Cable Mates:
S2SD, S2SDT



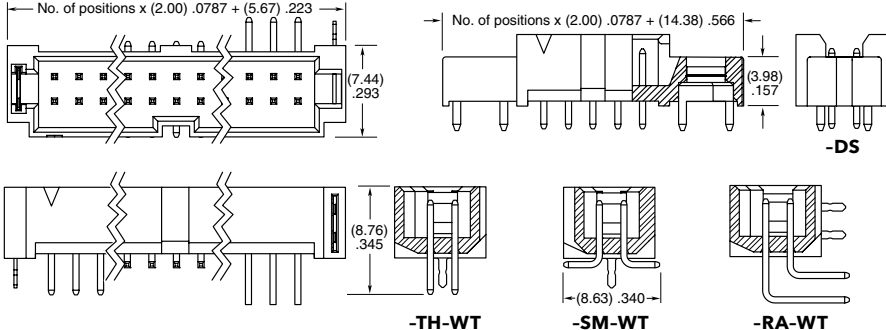

MATED HEIGHT

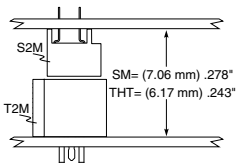

Note: Some lengths, styles and options are non-standard, non-returnable.

View complete specifications at: samtec.com?T2M

(2.00 mm) .0787" PITCH • CABLE ASSEMBLY/COMPONENTS



SERIES	PINS PER ROW	WIRE GAUGE	PLATING OPTION	ASSEMBLED LENGTH	END OPTIONS	END 2 OPTIONS
S2SD = Double Row PVC Cable	-05, -07, -10, -15, -20, -25, -30 (Standard sizes)	-24 -24C = Color Coded Cable (S2SD only)	-L = 10 μ" (0.25 μm) Gold on contact	-"XX.XX" = Wire Length in Inches (69.85 mm) 02.75" min.	-S = Single End -D = Double End	(Only available with -D, -DR & -DS) -NUS = Notch up, straight (Pin 1 to Pin N-1) -NDS = Notch down, straight (Pin 1 to Pin 2) -NUX = Notch up, crossed (Pin 1 to Pin N) -NDX = Notch down, crossed (Pin 1 to Pin 1)
S2SDT = Double Row Blue *Teflon® Cable (24, 28, 30 Gauge only)		-26 -28 -30			Specify "S" for single ended and "D" for double ended. -(XR) = Retention Latch (-SR mates with T2M-WT) -(XS) = Screw Down (10 positions minimum) (mates with T2M-DS)	

S2SD(T)
Board Mates:
T2M

SPECIFICATIONS

Insulator Material: Black LCP
Contact Material: BeCu
Plating: Au over 50 μ" (1.27 μm) Ni
Wire: 24, 26, 28 or 30 AWG
Operating Temp Range: -10 °C to +105 °C (PVC) -40 °C to +125 °C (*Teflon®)
Current Rating (S2SD-24/T2M): 3.8 A per pin (2 pins powered)
Voltage Rating: 250 VAC

-24C CABLE COLOR CODING

PIN	COLOR
1	BROWN
2	RED
3	ORANGE
4	YELLOW
5	GREEN
6	VIOLET
7	GRAY
8	WHITE
9	BLACK
10	BLUE
ETC	REPEAT

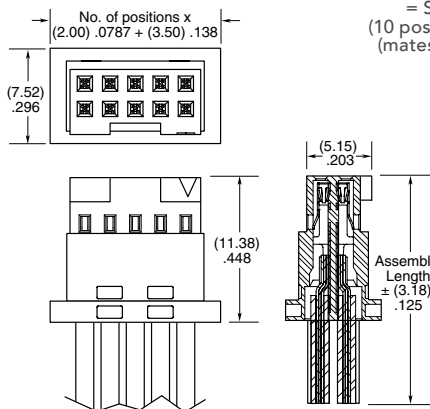

*DuPont™ Teflon® is a registered trademark of the E.I. du Pont de Nemours and Company or its affiliates.

Notes: Teflon® cable is intended for crimp only. Contact Samtec for solderable cable applications.

For wiring option information refer to drawings on web.

View complete specifications at: samtec.com?S2SD and samtec.com?S2SDT

ISD2	POSITIONS PER ROW	ROW OPTION	LATCH OPTION	SERIES	WIRE GAUGE	01	L
	-05, -07, -10, -15, -20, -25, -30 (Standard sizes)	-D = Double Row	-M = Metal Retention Latch -S = Screw Down	CC81L = Contact, Loose CC81R = Contact, Full Reel (17,000 Parts per Reel)	-2426 = 24 to 26 AWG -2830 = 28 to 30 AWG		-L = 10 μ" (0.25 μm) Gold on contact

Dimensions shown: (2.07) .081, (2.64) .104, (2.03) .080, (2.00) .079 DIA, (3.68) .145, (1.78) .070.

Dimensions shown: (12.35) .486, (3.17) .125.

TOOLING

Hand Tool: CAT-HT-281-2430-13	Mini Applicator: CAT-MC-281-2426-XX-01 (24-26 AWG)
Extraction Tool: CAT-EX-169-01	Mini Applicator: CAT-MC-281-2830-XX-01 (28-30 AWG)

Note: Some lengths, styles and options are non-standard, non-returnable.

View complete specifications at: samtec.com?ISD2, samtec.com?CC81R & samtec.com?CC81L



(2.00 mm) .0787" PITCH • DISCRETE WIRE CABLE ASSEMBLY

SERIES	PINS PER ROW	WIRE GAUGE	PLATING OPTION	ASSEMBLED LENGTH	END OPTIONS	END 2 OPTIONS
T2SD = Double Row PVC Cable T2SDT = Double Row Blue *Teflon® Cable (24, 28, 30 Gauge only)	-05, -07, -10, -15, -20, -25, -30 (Standard sizes)	-24 -24C = Color Coded Cable (T2SD only) -26 -28 -30	-L = 10 μ" (0.25 μm) Gold on contact	-"XX.XX" = Wire Length in Inches -S = (76.3 mm) 03.00" min. -D = (82.55 mm) 03.25" min.	-S = Single End -D = Double End -T = Transfer End (Socket on end 2) -TR = Transfer End with Retention Latch on Socket	(Only available with -D, -T & -TR) (See Chart for pin configuration) -NUS = Notch up, straight -NDS = Notch down, straight -NUX = Notch up, crossed -NDX = Notch down, crossed

T2SD(T)
Board Mates:
T2M (Requires -T or -TR), S2M

SPECIFICATIONS

Insulator Material: Black LCP
Terminal Material: Phosphor Bronze
Plating: Au over 50 μ" (1.27 μm) Ni
Wire: 24, 26, 28 or 30 AWG
Current Rating (T2SD/S2M): 2.6 A per pin (2 pins powered)
Operating Temp Range: -10 °C to +105 °C (PVC) -40 °C to +125 °C (*Teflon®)
Voltage Rating: 350 VAC

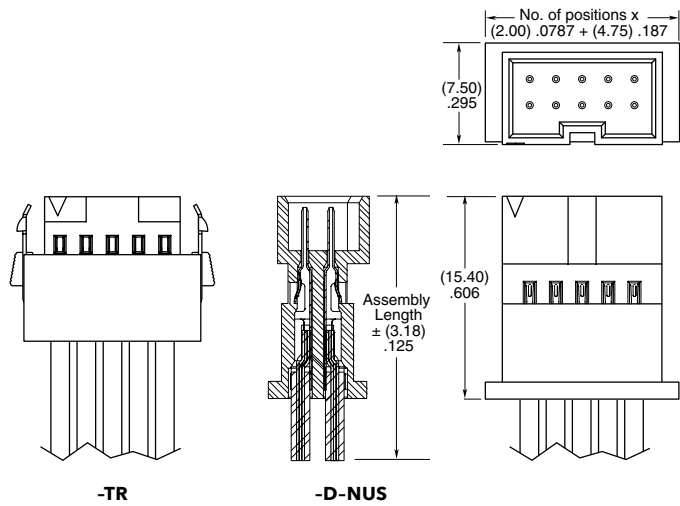

END 1 OPTION	PIN CONFIGURATION			
	END 2 -NUS	END 2 -NDS	END 2 -NUX	END 2 -NDX
-D	Pin 1 to Pin N-1	Pin 1 to Pin 2	Pin 1 to Pin N	Pin 1 to Pin 1
-T & -TR	Pin 1 to Pin 1	Pin 1 to Pin N	Pin 1 to Pin 2	Pin 1 to Pin N-1

-24C CABLE COLOR CODING	
PIN	COLOR
1	BROWN
2	RED
3	ORANGE
4	YELLOW
5	GREEN
6	VIOLET
7	GRAY
8	WHITE
9	BLACK
10	BLUE
ETC	REPEAT

*DuPont™ Teflon® is a registered trademark of the E.I. du Pont de Nemours and Company or its affiliates.

Notes:
Teflon® cable is intended for crimp only. Contact Samtec for solderable cable applications.
For wiring option information refer to drawings on web.

Some lengths, styles and options are non-standard, non-returnable.

View complete specifications at: samtec.com?T2SD & samtec.com?T2SDT

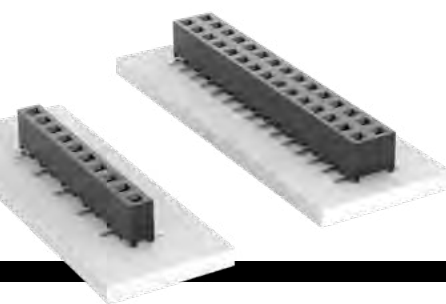

(2.00 mm) .0787" PITCH • TIGER EYE™ SOCKET

SMM	1	NO. PINS PER ROW	02	PLATING OPTION	ROW OPTION	OTHER OPTIONS
		02 thru 40		<p>-F = Gold flash on contact, Matte Tin on tail</p> <p>-L = 10 μ" (0.25 μm) Gold on contact, Matte Tin on tail</p> <p>-S = 30 μ" (0.76 μm) Gold on contact, Matte Tin on tail</p>	<p>-S = Single Row</p> <p>-D = Double Row</p>	<p>-“XX” = Polarized Position</p> <p>-K = (5.50 mm) .217" DIA Polyimide Film Pick & Place Pad (2 positions minimum, -02 thru -05 requires -TR)</p> <p>-P = Plastic Pick & Place Pad (-02 thru -05 requires -TR)</p> <p>-TR = Tape & Reel Packaging (27 positions maximum)</p> <p>-FR = Full Reel Tape & Reel (must order maximum quantity per reel; contact Samtec for quantity breaks) (27 positions maximum)</p>

SMM
Board Mates:
 TMM, TMMH, MTMM, MMT, LTMM, TW, PTT, ZLTMM
Cable Mates:
 TCMD

SPECIFICATIONS

Insulator Material:
 Black Liquid Crystal Polymer
Contact Material:
 BeCu
Plating: Sn or Au over
 50 μ" (1.27 μm) Ni
Current Rating (TMM/SMM):
 3.2 A per pin
 (2 pins powered)
Voltage Rating:
 350 VAC
Operating Temp Range:
 -55 °C to +125 °C
Insertion Depth:
 (3.05 mm) .120" to
 (3.25 mm) .128"
Max Cycles:
 100 with 10 μ" (0.25 μm) Au

PROCESSING

Lead-Free Solderable:
 Yes
SMT Lead Coplanarity:
 (0.15 mm) .006" max*
 *(.004" stencil solution may be available; contact ipg@samtec.com)

ALSO AVAILABLE
 MOQ Required

Locking Clip
 (Manual placement required)
 Other platings

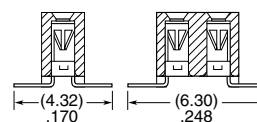
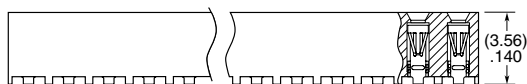
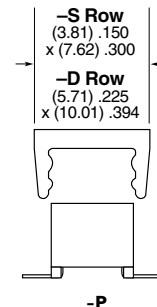
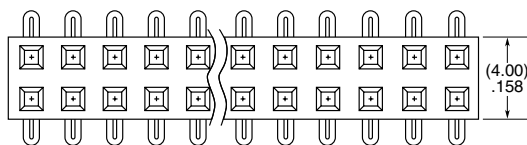
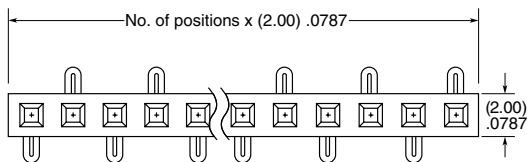

Note:
 Some lengths, styles and options are non-standard, non-returnable.

View complete specifications at: samtec.com?SMM

POWER & SEALED I/O

UP TO 60 AMPS • DESIGN FLEXIBILITY • IP67 & IP68 CIRCULARS & RECTANGULARS



196-199

ULTRA MICRO POWER

mPOWER® Ultra Micro Power Connectors (UMPT, UMPS, UMPC) 196-199

200-211

FLEX POWER SYSTEMS

PowerStrip™/20 Headers & Sockets (UPS, UPT, UPPT) 201
 PowerStrip™/30 Headers, Sockets, Cables & Components
 (MPT, MPS, MPSS, MPTC, MPSC, MPCC) 202-205
 PowerStrip™/40 Headers, Sockets, Cables & Components (PET, PES, PETC, PES, PESS) 206-207
 EXTreme LPHPower™ Terminals & Sockets (LPHT, LPHS) 208-209
 EXTreme Ten60Power™ Terminals & Sockets (ET60T, ET60S) 210-211

212-219

RUGGED POWER SYSTEMS

Mini Mate® Terminals, Sockets, Cables & Components (IPT1, IPS1, IPL1, MMSD) 212-215
 Power Mate® Terminals, Sockets, Cables & Components (IPBT, IPBS, PMSS, PMSD) 216-217
 .156" (3.96 mm) Pitch Headers & Sockets (FWJ, HFWJ, JW, FHP) 218
 .200" (5.08 mm) Pitch Headers & Sockets (HPM, HPW, HPF) 219

220-227

RUGGED SEALED I/O SYSTEMS

AccliMate™ Soldered IP68 Sealed Systems (ACX-12, ACX-16, ACX-22) 220-223
 AccliMate™ IP67 Sealed Systems (MCP, MCR) 224
 AccliMate™ Circular IP68 Sealed Systems (SCRUS, SCRES) 225
 AccliMate™ Rectangular IP68 Sealed Systems (RPBE, RPCE, RPBU, RPCU) 226-227

ULTRA MICRO POWER SYSTEM

(2.00 mm) .0787" PITCH



FEATURES & BENEFITS

- Up to 18 A per blade (1 blade powered)
- Design flexibility as a power-only system or a two-piece system for power/signal applications
- Use with Samtec's high-speed connector systems for a unique power/signal system (see chart page 197)
- Choice of 2 to 10 positions
- 5 mm to 12 mm stack heights available (up to 20 mm in development)
- Tin or 10 μ" Gold plated power blades; 30 μ" Gold plating available to meet specific regulations
- Optional weld tabs
- Cable-to-board and cable-to-cable systems in development

KEY SPECIFICATIONS

PITCH	STACK HEIGHTS	INSULATOR MATERIAL	CONTACT MATERIAL	PLATING	OPERATING TEMP RANGE	VOLTAGE RATING	LEAD-FREE SOLDERABLE
2.00 mm	5, 6, 7, 8 and 10 mm	Black LCP	Copper Alloy	Sn or Au over 50 μ" (1.27 μm) Ni	-55 °C to +105 °C with Tin -55 °C to +125 °C with Gold	460 VAC/ 650 VDC	Yes

UMPT/UMPS compared to another small form factor power solution

Terminals shown actual size at 4 positions



mPower®



Traditional Power Solutions

CREEPAGE & CLEARANCE

UMPT/UMPS	
CREEPAGE	2.20 mm
CLEARANCE	1.65 mm

Selectively loading contacts achieves customer specific creepage and clearance requirements.

MAX
18
A m p s

ULTRA MICRO POWER SOCKET

UMPS	NO. OF POSITIONS	LEAD STYLE	PLATING OPTION	VT	SM	OPTION	"X"R
	-02, -03, -04, -05, -06, -07, -08, -09, -10	-03.5 = (03.5 mm) .138" -05.5 = (05.5 mm) .217"	-L = 10 μ" (0.25 μm) Gold on contact, Matte Tin on tail -G = 10 μ" (0.25 μm) Gold on contact, Gold flash on tail -T = Matte Tin			-WT = Weld Tab Through-hole (Leave blank for no weld tab) -K = Polyimide Pick & Place Pad (Leave blank for no pad)	(Leave blank for Tape & Reel) -FR = Full Reel Tape & Reel (must order max. quantity per reel; contact Samtec for quantity breaks)

*-06 thru -10
PRELIMINARY*

UMPS
Board Mates:
UMPT

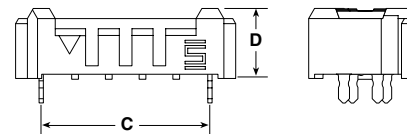
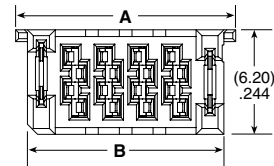

UMPS-04-03.5-X-VT-SM-WT SHOWN

NO. OF POSITIONS	A	B	C
-02	(9.05) .356	(7.65) .301	(6.00) .236
-03	(11.05) .435	(9.65) .380	(8.00) .315
-04	(13.05) .514	(11.65) .459	(10.00) .394
-05	(15.05) .593	(13.65) .537	(12.00) .472
-06	(17.05) .671	(15.65) .616	(14.00) .551
-07	(19.05) .750	(17.65) .695	(16.00) .630
-08	(21.05) .829	(19.65) .774	(18.00) .709
-09	(23.05) .907	(21.65) .852	(20.00) .787
-10	(25.05) .986	(23.65) .931	(22.00) .866

LEAD STYLE	D
-03.5	(4.15) .163
-05.5	(6.15) .242

SIGNAL CONNECTOR	MATED HEIGHT					
	5 mm	6 mm	7 mm	8 mm	10 mm	12 mm
ADM6/ADF6	X					
BTE/BSE	X			X		
BTH/BSH, BTS/BSS	X					
ERM5/ERF5			X		X	X
ERM6/ERF6	X				X	X
ERM8/ERF8			X		X	X
LPAM/LPAF	X					
QMS/QFS					X	
QRM8/QRF8			X		X	X
QTE/QSE, QTH/QSH, QTS/QSS	X					
SEAM/SEAF			X	X	X	X
SEAM8/SEAF8			X		X	
ST4/SS4	X	X				
ST5/SS5	X					
TEM/SEM		X	X		X	

UMPT/UMPS CURRENT RATING (PER CONTACT)

PINS	-T	-G
1	18.3 A	16.2 A
2	14.5 A	14.6 A
3	14.2 A	12.6 A
4	12.9 A	12.3 A
5	12.9 A	N/A
10	N/A	9.4 A

Ratings are derated 20% and based on 70 °C ambient temperature with maximum allowable rise.

Notes:
Some lengths, styles and options are non-standard, non-returnable

View complete specifications at: samtec.com?UMPS

ULTRA MICRO POWER TERMINAL

UMPT	NO. OF POSITIONS	LEAD STYLE	PLATING OPTION	VT	SM	WELD TAB	LATCH OPTION	K
	-02, -03, -04, -05, -06, -07, -08, -09, -10	-01.5 = (01.5 mm) .059"	-L = 10 μ" (0.25 μm) Gold on contact, Matte Tin on tail			(Leave blank for no weld tab) -WT = Weld Tab Through-hole	(Leave blank for no latch) (Only available on -02.5 lead style) (Weld tab required) -P = Plastic top latch -M = Metal side latches	-K = Polyimide Pick & Place Pad
		-02.5 = (02.5 mm) .098"	-G = 10 μ" (0.25 μm) Gold on contact, Gold flash on tail					
		-06.5 = (06.5 mm) .256"	-T = Matte Tin					

*-02.5,
-06 thru -10,
-P & -M
PRELIMINARY*

UMPT
Board Mates:
UMPS
Cable Mates:
UMPC

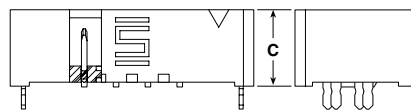
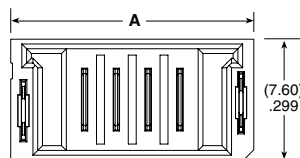

UMPT-04-01.5-X-VT-SM-WT SHOWN

LEAD STYLE	C	NO. OF POSITIONS	A		B	
			(-P & No latch)	(-M latch)	(-P & No latch)	(-M latch)
-01.5	(4.80) .189	-02	(11.30) .445	(9.70) .382	(13.30) .524	(11.60) .457
-02.5	(5.80) .228	-03	(13.30) .524	(11.70) .460	(15.30) .602	(13.60) .535
-06.5	(9.55) .376	-04	(15.30) .602	(13.70) .539	(17.30) .681	(15.60) .614
		-05	(17.30) .681	(15.70) .618	(19.30) .760	(17.60) .693
		-06	(19.30) .760	(17.70) .697	(21.30) .839	(19.60) .772
		-07	(21.30) .839	(19.70) .776	(23.30) .917	(21.60) .850
		-08	(23.30) .917	(21.70) .854	(25.30) .996	(23.60) .929
		-09	(25.30) .996	(23.70) .933	(27.30) 1.075	(25.60) 1.007
		-10	(27.30) 1.075	(25.70) 1.012	(29.30) 1.154	(27.60) 1.087

Note:
Some lengths, styles and options are non-standard, non-returnable.

View complete specifications at: samtec.com?UMPT

UMPT	NO. OF POSITIONS	01	PLATING OPTION	RA	WELD TAB	LATCH OPTION	"X"R
	-02, -03, -04, -05, -06, -07, -08, -09, -10		-L = 10 μ" (0.25 μm) Gold on contact, Matte Tin on tail		-WT = Weld Tab Through-hole	(Leave blank for no latch) -P = Plastic top latch	-TR = Tape & Reel -FR = Full Reel Tape & Reel (must order max. quantity per reel; contact Samtec for quantity breaks)
			-S = 30 μ" (0.76 μm) Gold on contact, Matte Tin on tail			-M = Metal side latches	
			-T = Matte Tin				

UMPT-RA
Board Mates:
UMPS
Cable Mates:
UMPC



*-P & -M
PRELIMINARY*

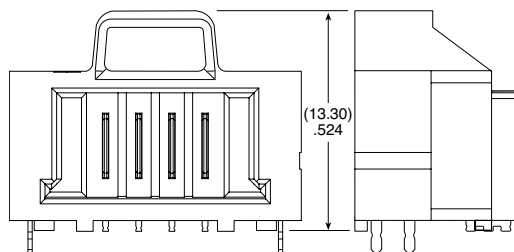

UMPT-04-01-X-RA-WT-P SHOWN

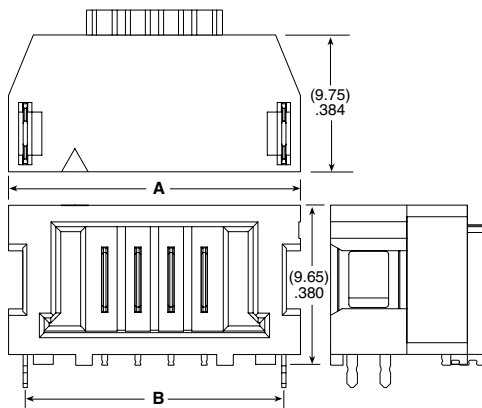

UMPT-04-01-X-RA-WT-M SHOWN

NO. OF POSITIONS	A	B	
		(-P & No latch)	(-M latch)
-02	(13.60) .535	(11.10) .437	(11.55) .455
-03	(15.60) .614	(13.10) .516	(13.55) .533
-04	(17.60) .693	(15.10) .594	(15.55) .612
-05	(19.60) .772	(17.10) .673	(17.55) .691
-06	(21.60) .850	(19.10) .752	(19.55) .770
-07	(23.60) .929	(21.10) .831	(21.55) .848
-08	(25.60) 1.008	(23.10) .909	(23.55) .927
-09	(27.60) 1.087	(25.10) .988	(25.55) 1.006
-10	(29.60) 1.165	(27.10) 1.067	(27.55) 1.085

Note:
Some lengths, styles and options are non-standard, non-returnable.

View complete specifications at: samtec.com?UMPT-RA

ULTRA MICRO POWER CABLE



UMPC	NO. OF POSITIONS	PLATING OPTION	WIRE GAUGE	COLOR CODE	LATCH OPTION	LENGTH	PINOUT
	-02, -03, -04, -05, -06, -07, -08, -09, -10	-L = 10 μ" (0.25 μm) Gold on contact, Tin on tail -S = 30 μ" (0.76 μm) Gold on contact, Tin on tail -T = Tin	-16 -18	(Leave blank for standard wire) -C = Color Coded Cable (See table for coding)	-P = Plastic top latch -M = Metal side latches	-“XX.X” = Assembled Length in Inches (76.20 mm) 03.00" min.	(Leave blank for single ended) -1 = Pin 01 to Pin 01 -2 = Pin 01 to Pin N

PRELIMINARY

UMPC
Cable Mates:
UMPT

SPECIFICATIONS

Insulator Material:
Black LCP
Contact Material:
Copper Alloy
Plating:
Sn or Au over
50 μ" (1.27 μm) Ni
Wire:
16 or 18 AWG
Operating Temp Range:
Testing Now!
Current Rating:
Testing Now!
Voltage Rating:
300V PVC

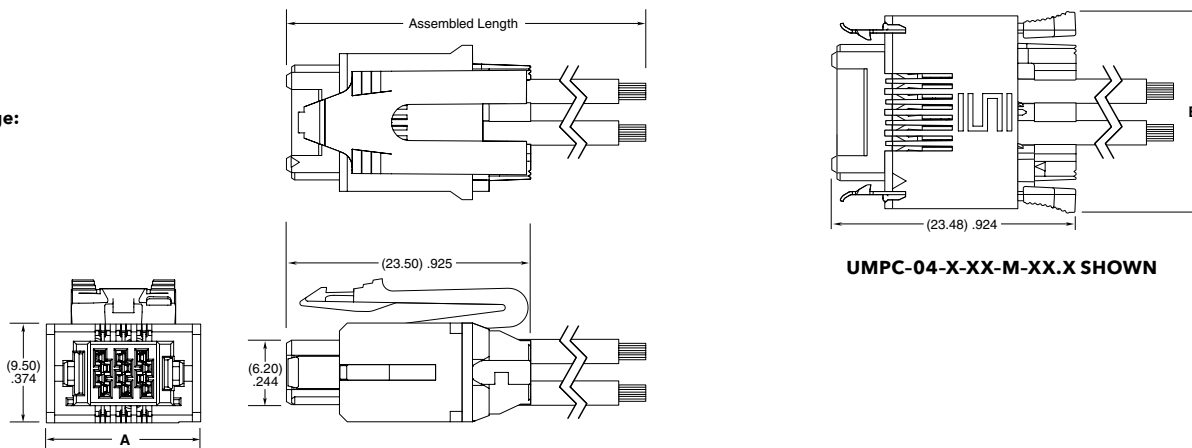

UMPC-03-X-XX-P-XX.X SHOWN

UMPC-04-X-XX-M-XX.X SHOWN

UMPC/UMPT (TIN PLATING)	
PINS	CURRENT RATING (PER CONTACT)
1	16.8 A
2	14.6 A
3	12.6 A
4	11.6 A
10	8.8 A

NO. OF POSITIONS	A	B
-02	(12.85) .506	(15.38) .605
-03	(14.85) .585	(17.38) .684
-04	(16.85) .663	(19.38) .763
-05	(18.85) .742	(21.38) .842
-06	(20.85) .821	(23.38) .920
-07	(22.85) .900	(25.38) .999
-08	(24.85) .978	(27.38) 1.078
-09	(26.85) 1.057	(29.38) 1.157
-10	(28.85) 1.136	(31.38) 1.235

CABLE COLOR CODING	
PIN	COLOR
1	BROWN
2	RED
3	ORANGE
4	YELLOW
5	GREEN
6	BLUE
7	VIOLET
8	GRAY
9	WHITE
10	BLACK

Notes:
For wiring option information
refer to drawings on web.

Some lengths, styles and
options are non-standard,
non-returnable.

View complete specifications at: samtec.com?UMPC

HIGH-POWER SYSTEMS

20-60 A
per blade

FEATURES & BENEFITS

- Current Rating: 23 A - 58.7 A per power blade
- 3.81 mm, 5.00 mm and 6.35 mm pitch
- Dual blade contact system
- Power only or power/signal combinations available
- Right-angle and vertical orientations
- Rugged screw down and locking clip options
- Discrete wire cable assembly with 10-16 AWG wire
- "Hinged" for unique mating in any orientation from 0° to 90° and space confined applications

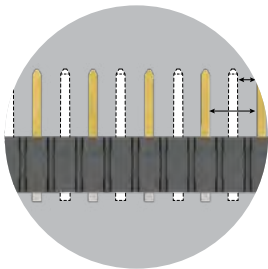

Selectively loading contacts achieves customer specific creepage and clearance requirements.

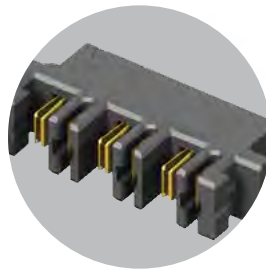

Hermaphroditic options available (samtec.com?MPPT)

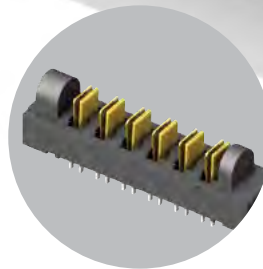

Hinging options available (samtec.com?FMPT samtec.com?FMPS)

KEY SPECIFICATIONS

SERIES	PET/PES	PETC/PESC	MPT/MPS	MPTC/MPSC	UPT/UPS	FMPT/FMPS	UPPT	MPPT
PITCH	(6.35 mm) .250"	(6.35 mm) .250" (pwr) (2.54 mm) .100" (sig)	(5.00 mm) .1969"	(5.00 mm) .197" (pwr) (2.00 mm) .079" (sig)	(3.81 mm) .150"	(5.00 mm) .1969"	(3.81 mm) .150"	(5.00 mm) .1969"
CCC (1 PIN)*	58.7 A	31.4 A	28.8 A	28.8 A	23 A	26.7 A	21.4 A	23.3 A
CCC (2 PINS)*	48.5 A	28.0 A	24.7 A	24.7 A	18.6 A	22.9 A	19.8 A	20.5 A
CCC (3 PINS)*	41.1 A	24.4 A	24.1 A	24.1 A	17.5 A	19.1 A	17.1 A	19.4 A
CREEPAGE	(3.66 mm) .144"	(3.66 mm) .144"	(2.86 mm) .113"	(2.86 mm) .113"	(5.5 mm) .217"	(6.53 mm) .257"	(1.91 mm) .075"	(2.95 mm) .116"
CLEARANCE	(3.31 mm) .130"	(3.31 mm) .130"	(2.71 mm) .106"	(2.71 mm) .106"	(1.51 mm) .059"	(2.71 mm) .106"	(1.51 mm) .059"	(2.71 mm) .106"
VAC	725 VAC	Signal: 450 VAC Power: 650 VAC	575 VAC	250 VAC	438 VAC	525 VAC	425 VAC	600 VAC
VDC	1025 VDC	Signal: 636 VDC Power: 919 VDC	812 VDC	354 VDC	620 VDC	742 VDC	600 VDC	848 VDC
CYCLES	100	100	100	100	25	100	100	100

(3.81 mm) .150" PITCH • 20 A DUAL BLADE/LEAF POWER SYSTEMS

SERIES	POWER PINS	LEAD STYLE	TAIL LENGTH	PLATING OPTION	TAIL	OTHER OPTION
UPT Terminal	-02	-01 = RA only	-01 = Use with (1.60 mm) .062" Thick PCB (-V & -RA only)	-L = 10 μ" (0.25 μm) Gold on contact, Matte Tin on tail	-V = Vertical (Not available with -T plating)	-LC = Locking Clip (Manual placement required) Not available with -PV option
	-04	-03.0 = (03.0 mm) .118" (UPT-V & UPT-PV only)				
UPS Socket	-06	-04.0 = (04.0 mm) .157" (UPS-V & UPS-PV only)	-03 = Use with (1.60 mm) .062" Thick PCB (-PV only)	-T = Matte Tin (-RA & -PV options only)	-RA = Right-angle	
	-08	-07.0 = (07.0 mm) .276" (UPS-V & UPS-PV only)			-PV = Press-fit, Vertical	

UPT
Board Mates:
UPS

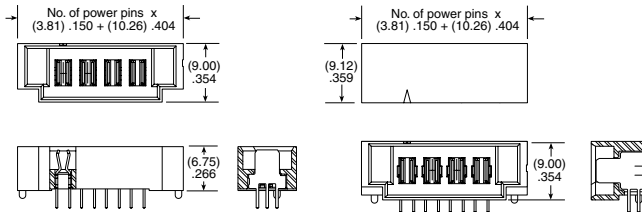

MATED HEIGHT*	
UPS LEAD STYLE	UPT LEAD STYLE
	-03.0
-04.0	(7.00) .276
-07.0	(10.00) .394

*Processing conditions will affect mated height.

UPS
Board Mates:
UPT

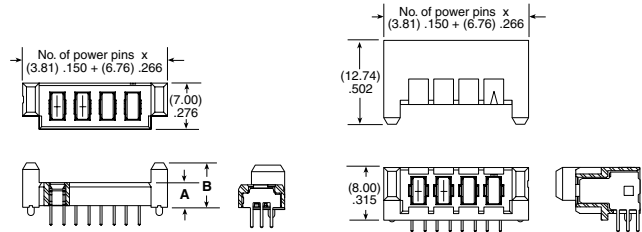

LEAD STYLE	A	B
-04.0	(3.75) .148	(6.75) .266
-07.0	(6.75) .266	(9.75) .384

View complete specifications at: samtec.com?UPT & samtec.com?UPS

SERIES	NO. OF POSITIONS	01	TAIL LENGTH	PLATING OPTION	RA	SD	"X"R
--------	------------------	----	-------------	----------------	----	----	------

UPPT
Hermaphroditic

-02, -04, -06, -08

-01
= (1.60 mm) .062"
Thick PCB

-L
= 10 μ" (0.25 μm)
Gold on contact,
Matte Tin on tail

-T
= Matte Tin

Leave blank for tube packaging

-TR
= Tape & Reel

-FR
= Full Reel
Tape & Reel
(must order max. quantity per reel; contact Samtec for quantity breaks)

UPPT
Board Mates:
UPPT

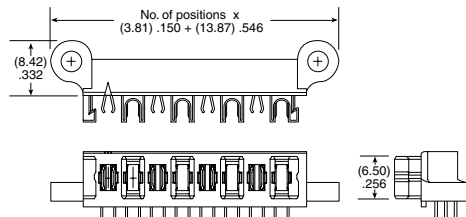
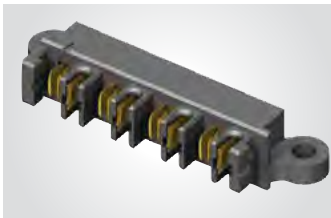

View complete specifications at: samtec.com?UPPT

Note:
Some lengths, styles and options are non-standard, non-returnable

(5.00 mm) .1969" PITCH • 30 A DUAL BLADE/LEAF SYSTEMS

SERIES	POWER PINS	LEAD STYLE	TAIL LENGTH	PLATING OPTION	TAIL
MPT Terminal	-02, -03, -04,	-6.30 = (6.30 mm) 0.248" (MPT only)	-01 = Use with (1.60 mm) .062" Thick PCB -03 = Use with (2.36 mm) .093" Thick PCB	-L = 10 μ" (0.25 μm) Gold on contact, Matte Tin on tail -T = Matte Tin	(Required Callout) -V = Vertical
MPS Socket	-06, -08	-7.70 = (7.70 mm) 0.303" (MPS only)			

MPT

Board Mates:

MPS

Cable Mates:

MPSS

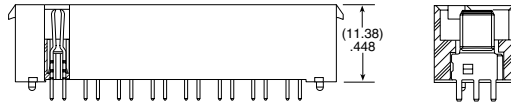
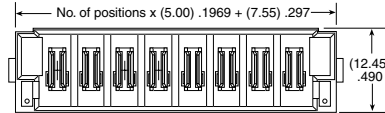

MATED HEIGHT

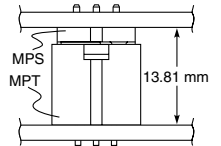

MPS

Board Mates:

MPT

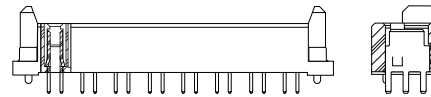
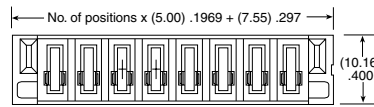
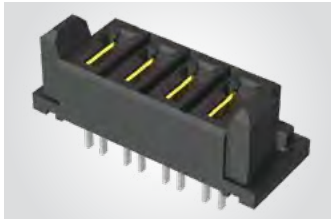

View complete specifications at: samtec.com?MPT & samtec.com?MPS

SERIES	POWER PINS	01	TAIL LENGTH	PLATING OPTION	RA	SD
MPT Terminal	-02, -04, -06, -08		-01 = Use with (1.60 mm) .062" Thick PCB -03 = Use with (2.36 mm) .093" Thick PCB	-L = 10 μ" (0.25 μm) Gold on contact, Matte Tin on tail -T = Matte Tin		
MPS Socket						

MPT-RA

Board Mates:

MPS

Cable Mates:

MPSS

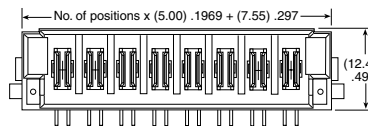
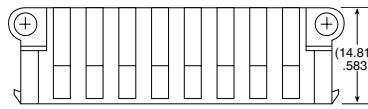

MPS-RA

Board Mates:

MPT

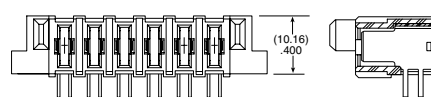
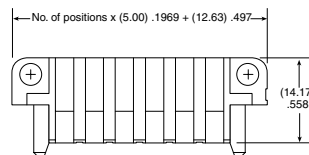

Note:
Some lengths, styles and options are non-standard, non-returnable

View complete specifications at: samtec.com?MPT & samtec.com?MPS



(5.00 mm) .1969" PITCH • 30 A CABLE ASSEMBLY/COMPONENTS

MPSS	NO. OF POSITIONS	WIRE GAUGE	PLATING OPTION	ASSEMBLED LENGTH	END 1 OPTION	END 2 OPTION
------	------------------	------------	----------------	------------------	--------------	--------------

-02, -03,
-04, -06, -08

-14
-16

-L
= 10 μ" (0.25 μm)
Gold on contact

-T
= Matte Tin

-"XX.XX"
= Wire length in
inches (83.00 mm)
03.25" min.

-SR
= Single End

-DR
= Double End

(Available with -DR only)

-NUS
= Notch up, straight

-NDS
= Notch down, straight

MPSS

Board Mates:

MPT

SPECIFICATIONS

Insulator Material:

Nylon 6/6

Contact Material:

Copper Alloy

Plating:

Au or Sn over

50 μ" (1.27 μm) Ni

Latch:

Nylon 6/6

Operating Temp Range:

-30 °C to +105 °C

Voltage Rating:

600 VAC/848 VDC

Wire:

14 or 16 AWG

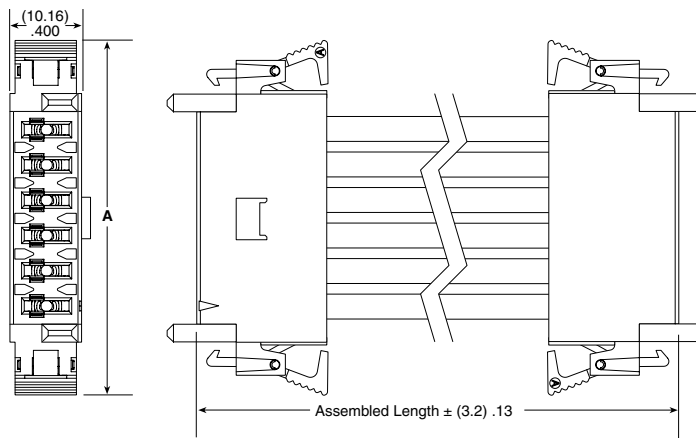

NO. OF POSITIONS	A
-02	(30.07) 1.184
-03	(35.07) 1.381
-04	(40.08) 1.578
-06	(50.09) 1.972
-08	(60.10) 2.366

MPSS/MPT-V	
WIRE GAUGE	CURRENT RATING (PER PIN)
14 AWG	19.7 A
16 AWG	15.9 A
1 PIN POWERED	

View complete specifications at: samtec.com?MPSS

IMS5	POSITIONS PER ROW	02	SERIES	WIRE GAUGE	01	PLATING OPTION
------	-------------------	----	--------	------------	----	----------------

-02, -03, -04, -06, -08

CC46L
= Contact, Loose

-1416
= 14 to 16 AWG

-L
= 10 μ" (0.25 μm)
Gold on contact

CC46R
= Contact,
Full Reel

-T
= Matte Tin

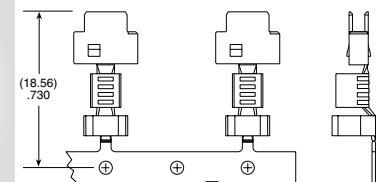
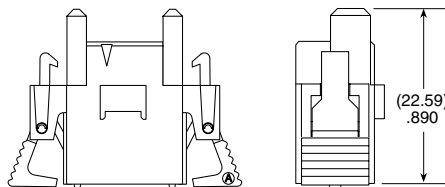
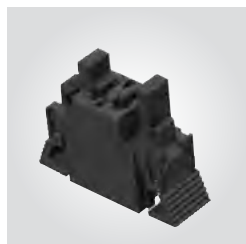

TOOLING

Hand Tool: CAT-HT-246-1416-14 (14-16 AWG)

Mini Applicator: CAT-MC-246-1416-XX-02 (14-16 AWG)

Extraction Tool: CAT-EX-MPSS-01

Note:

Some lengths, styles and options are non-standard, non-returnable

View complete specifications at: samtec.com?IMS5, samtec.com?CC46L & samtec.com?CC46R

(5.00 mm) .197"(PWR) / (2.00 mm) .079"(SIG) • 30 A SIGNAL/POWER COMBO SYSTEMS

SERIES	POWER PINS	SIGNAL PINS	POWER PINS	LEAD STYLE	TAIL LENGTH	PLATING OPTION	V	OTHER OPTION
MPTC Terminal	Per end -01	-16 -24	Per end -01	-6.30 = (6.30 mm) 0.248" (MPTC only)	-01 = Use with (1.60 mm) .062" Thick PCB	-L = 10 μ" (0.25 μm) Gold on contact, Matte Tin on tail (Power & Signal)		-LC = Locking Clip (Manual placement required)
MPSC Socket	-02	-40 -80	-02	-7.70 = (7.70 mm) 0.303" (MPSC only)	-03 = Use with (2.36 mm) .093" Thick PCB	-T = Matte tin on contact and tail (power), Gold on contact, Matte tin on tail (Signal)		

MPTC
Board Mates:
MPSC
Cable Mates:
MPCC

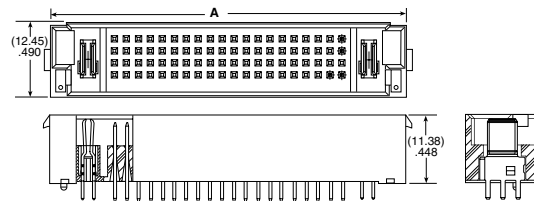

POWER PINS/ENDS	A			
	16 SIGNAL PINS	24 SIGNAL PINS	40 SIGNAL PINS	80 SIGNAL PINS
-01	(27.44) 1.081	(31.45) 1.238	(39.44) 1.553	(59.44) 2.340
-02	(37.44) 1.474	(41.45) 1.632	(49.44) 1.946	(69.44) 2.734

MPSC
Board Mates:
MPTC

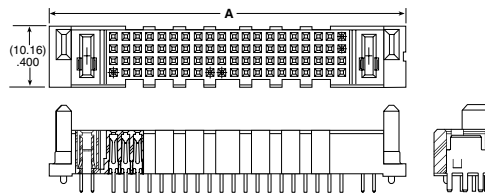
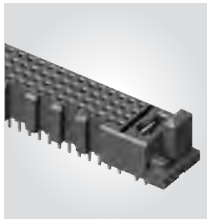

View complete specifications at: samtec.com?MPTC & samtec.com?MPSC

SERIES	POWER PINS	SIGNAL PINS	POWER PINS	01	TAIL LENGTH	PLATING OPTION	RA	OTHER OPTION
MPTC Terminal	Per end -01	-24 -80	Per end -01		-01 = Use with (1.60 mm) .062" Thick PCB	-L = 10 μ" (0.25 μm) Gold on contact, Matte Tin on tail (Power & Signal)		-SD or -LC is a required callout
MPSC Socket	-02		-02		-03 = Use with (2.36 mm) .093" Thick PCB	-T = Matte Tin on contact and tail (power), Gold on contact, Matte tin on tail (Signal)		-SD = Screw Down -LC = Locking Clip (Manual placement required)

MPTC-RA
Board Mates:
MPSC
Cable Mates:
MPCC

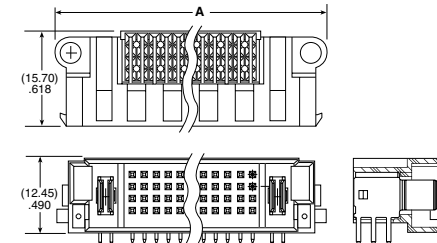

POWER PINS/ENDS	A	
	24 SIGNAL PINS	80 SIGNAL PINS
-01	(35.25) 1.388	(63.25) 2.490
-02	(45.25) 1.781	(73.25) 2.884

MPSC-RA
Board Mates:
MPTC

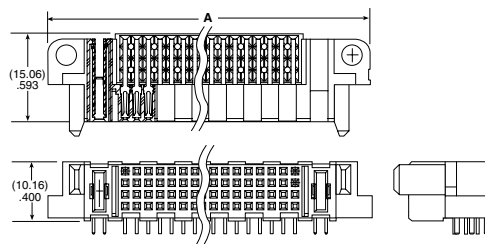
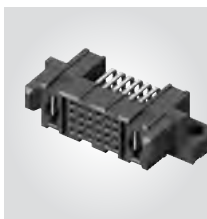

POWER PINS/ENDS	A	
	24 SIGNAL PINS	80 SIGNAL PINS
-01	(36.25) 1.438	(64.25) 2.540
-02	(46.25) 1.831	(74.25) 2.934

Note: Some lengths, styles and options are non-standard, non-returnable

View complete specifications at: samtec.com?MPTC & samtec.com?MPSC



30 SIGNAL/POWER COMBO CABLE ASSEMBLY/COMPONENTS

MPCC	2	SIGNAL PINS	2	PLATING OPTION	LEAD STYLE	LENGTH	END 1 OPTION	END 2 OPTION
		-16 = Total Signal Pins		-L = 10 μm (0.25 μm) Gold on contact, Tin on tail (Power & Signal)	Specify LEAD STYLE from chart	-"XX.XX" = Assembled Length in Inches (101.60 mm) 04.00" min.	-S = Single End	(Available with -D only)
		-24 = Total Signal Pins		-T = Tin on contact and tail (Power), Gold on contact, Tin on tail (Signal)			-D = Double End	-NUS = Notch up, straight (Pin A1 to Pin AX)

MPCC
Board Mates:
MPTC

SPECIFICATIONS

Insulator Material:
Black LCP
Contact Material:
Signal: BeCu
Power: Copper Alloy
Plating:
Sn or Au over 50 μm (1.27 μm) Ni
Current Rating:
Signal Pin (24 AWG):
3.4 A per pin
(4 adjacent pins powered)
Power Pin (14 AWG):
23.2 A per pin
(1 pin powered)
Operating Temp Range:
-10 °C to +105 °C
Voltage Rating:
300 VAC

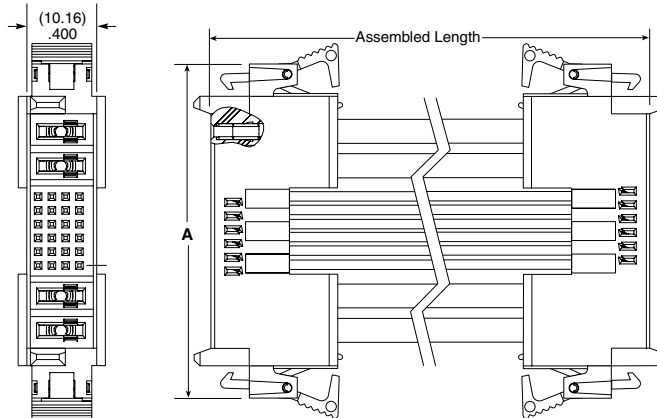

SIGNAL PINS	A
16	(44.55) 1.754
24	(48.55) 1.911

LEAD STYLE	PWR/SIG	AWG
-44	PWR	14
	SIG	24
-46	PWR	14
	SIG	26
-48	PWR	14
	SIG	28
-40	PWR	14
	SIG	30
-64	PWR	16
	SIG	24
-66	PWR	16
	SIG	26
-68	PWR	16
	SIG	28
-60	PWR	16
	SIG	30

View complete specifications at: samtec.com?MPCC

IMSC5	POWER PINS	SIGNAL PINS	POWER PINS	L	SERIES	WIRE GAUGE	01	PLATING OPTION
	-02 = Power Pins Per End	-16 = Total Signal Pins	-02 = Power Pins Per End	-L = Latch	CC81L = Contact, Loose	-2426 = 24 to 26 AWG		-L = 10 μm (0.25 μm) Gold on contact
		-24 = Total Signal Pins			CC81R = Contact, Full Reel (17,000 Parts per Reel)	-2830 = 28 to 30 AWG		

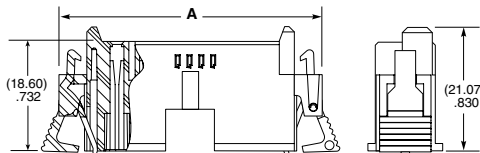

SIGNAL PINS	A
-16	(44.55) 1.754
-24	(48.55) 1.911

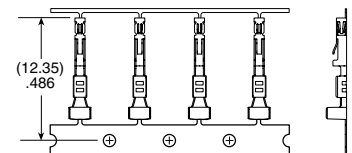

Note: Power contact (CC46 Series) information on page 203.

TOOLING

Hand Tool: CAT-HT-281-2430-11 (Signal: 24-30 AWG)
CAT-HT-246-1416-11 (Power: 14-16 AWG)

Extraction Tool: CAT-EX-169-01 (Signal)
CAT-EX-MPSS-01 (Power)

Mini Applicator: CAT-MC-246-1416-XX-01 (Power 14-16 AWG)
CAT-MC-281-2426-XX-01 (Signal: 24-26 AWG)
CAT-MC-281-2830-XX-01 (Signal: 28-30 AWG)

Note: Some lengths, styles and options are non-standard, non-returnable

View complete specifications at: samtec.com?IMSC5, samtec.com?CC81R & samtec.com?CC81L

POWER STRIP™ 40

(6.35 mm) .250" PITCH • 40 A HIGH-POWER SYSTEM

SERIES	NO. PINS PER ROW	LEAD STYLE	PLATING OPTION	TAIL OPTION	OTHER OPTION
--------	------------------	------------	----------------	-------------	--------------

PET
Terminal

-02, -04, -06, -08

-01
= Use with (1.60 mm) .062" Thick PCB

-L
= 10 μm (0.25 μm) Gold on contact, Matte Tin on tail

-VT
= Vertical

-SD
= Screw Down (Right-angle only)

PES
Socket

-02
= Use with (3.18 mm) .125" Thick PCB

-T
= Matte Tin on tail

-RA
= Right-angle (Screw Down option required)

PET
Board Mates:
PES
Cable Mates:
PESS

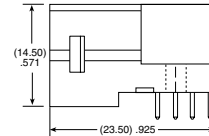
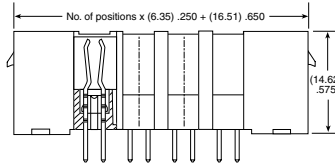

-VT

-RA-SD

PES
Board Mates:
PET

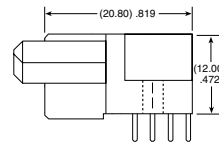
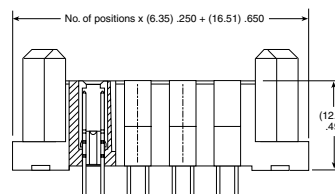

-VT

-RA-SD

View complete specifications at: samtec.com?PET & samtec.com?PES

SERIES	POWER PINS	SIGNAL PINS	POWER PINS	01	PLATING OPTION	TAIL	OTHER OPTION
--------	------------	-------------	------------	----	----------------	------	--------------

PETC
Terminal

**-01
-02
-04**

**-12
-40**

**-01
-02
-04**

-L
= 10 μm (0.25 μm) Gold on contact, Matte Tin on tail

-VT
= Vertical

-SD
= Screw Down (Right-angle only)

PESC
Socket

-T
= Matte Tin

-RA
= Right-angle

-LC
= Locking Clip (Manual placement required)

PETC
Board Mates:
PESC

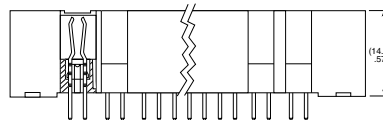
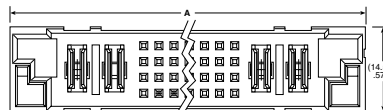

PESC
Board Mates:
PETC

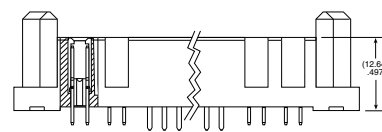
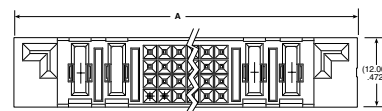
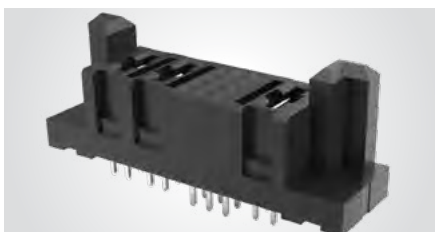

POWER PINS/ENDS	A	
	12 SIGNAL PINS	40 SIGNAL PINS
-01	(39.37) 1.550	(57.15) 2.250
-02	(52.07) 2.050	(69.85) 2.750
-04	(77.47) 3.050	(95.25) 3.750

View complete specifications at: samtec.com?PETC & samtec.com?PESC

Note:
Some lengths, styles and options are non-standard, non-returnable



(6.35 mm) .250" PITCH • 40 A CABLE ASSEMBLY/COMPONENTS

PESS	NO. OF POSITIONS	WIRE GAUGE	PLATING OPTION	ASSEMBLED LENGTH	END 1 OPTION	END 2 OPTION
	-02, -04, -06, -08	-10 -12	-L = 10 μ" (0.25 μm) Gold on contact, Matte Tin on tail -T = Matte Tin on tail	-"XX.XX" = Wire length in inches (152.4 mm) 06.00" min.	-SR = Single End -DR = Double End	(Available with -DR only) -NUS = Notch up, straight (Available with -DR only) -NDS = Notch down, straight

PESS
Board Mates:
PET

SPECIFICATIONS

Insulator Material:
Nylon Black
Contact Material:
Copper Alloy
Plating:
Sn or Au over
50 μ" (1.27 μm) Ni
Operating Temp Range:
-30 °C to +105 °C
Voltage Rating:
600 VAC
846 VDC
Wire:
10 or 12 AWG

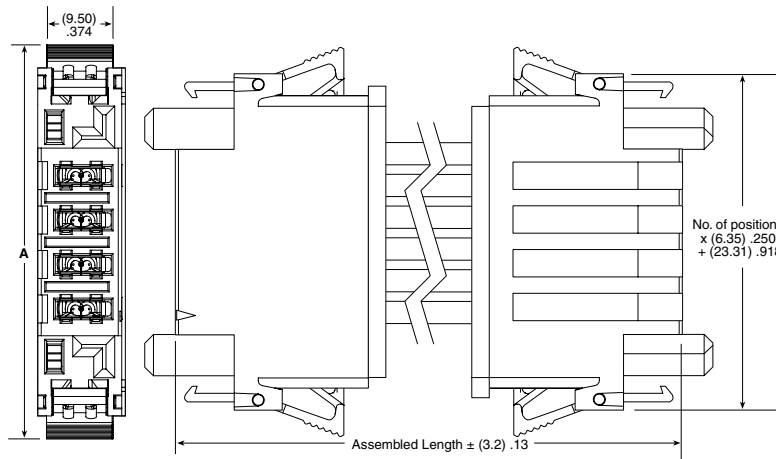

NO. OF POSITIONS	A
-02	(43.9) 1.73
-04	(56.6) 2.23
-06	(69.3) 2.73
-08	(82.0) 3.23

PESS/PET	
WIRE GAUGE	CURRENT RATING (PER PIN)
10 AWG	34.5 A
12 AWG	29.7 A

1 PIN POWERED

View complete specifications at: samtec.com?PESS

IPS6	POSITIONS PER ROW	01	LATCH	SERIES	WIRE GAUGE	PLATING OPTION
	-02, -04, -06, -08		-L = Latch	CC10R = Contact, Full Reel CC10L = Contact, Loose	-1012 = 10 to 12 AWG	-L = 10 μ" (0.25 μm) Gold on contact, Matte Tin on tail -T = Matte Tin on tail

TOOLING

Hand Tool: CAT-HT-310-1012-14
Mini Applicator: CAT-MC-310-1012-XX-02

Note:
Some lengths, styles and options are non-standard, non-returnable

View complete specifications at: samtec.com?IPS6, samtec.com?CC10L & samtec.com?CC10R

LOW-PROFILE, EXTREME HIGH-POWER/SIGNAL COMBO

FEATURES & BENEFITS

- 30 A per power blade and 1 A per signal pin
- Low 7.5 mm profile design (right-angle) for improved system airflow and space savings
- Double-stacked power blades per bank for increased density and power
- Ideal for coplanar and perpendicular applications
- Rugged guide posts are standard for blind mating assistance
- Socket available as vertical with press-fit tails and right-angle through-hole; mates with terminal or standard .062" (1.60 mm) PCB card

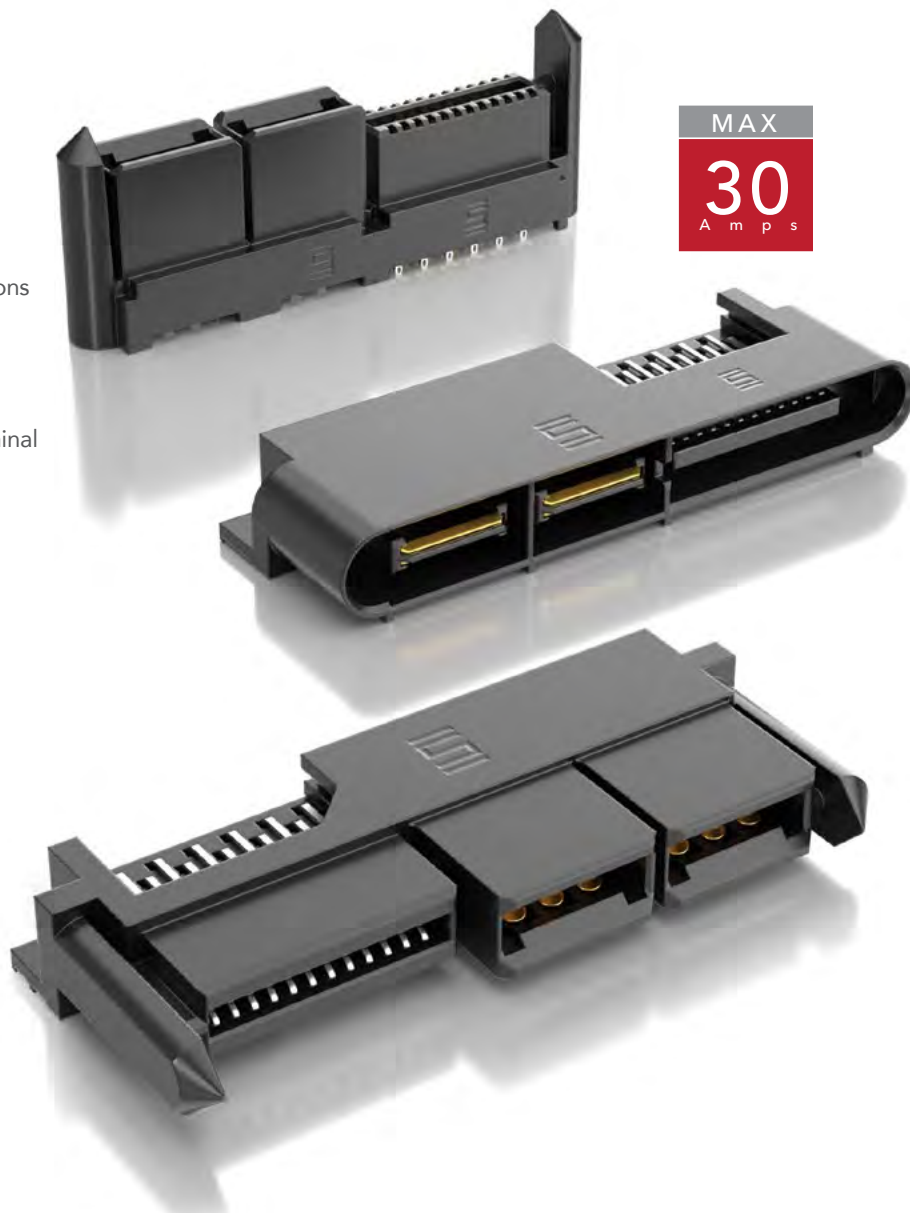

Standard Creepage*	5.63 mm
Standard Clearance*	2.69 mm

*Selectively loading contacts achieves customer specific creepage and clearance requirements. Contact asp@samtec.com

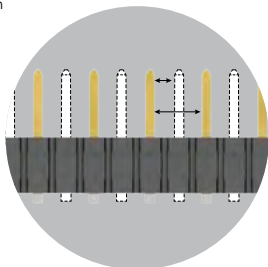

KEY SPECIFICATIONS

PITCH	INSULATOR MATERIAL	TERMINAL MATERIAL	PLATING	OPERATING TEMP RANGE	VOLTAGE RATING	MATING CYCLES	LEAD-FREE SOLDERABLE
(12.00 mm) .472" (pwr) (1.27 mm) .050" (sig)	Black LCP	Signal: Brass Power: Copper Alloy	Au or Sn over 50 μ" (1.27 μm) Ni	40 °C to +105 °C	250 VAC / 500 VDC	250 (MFG Tested)	Yes (RT1 & RT2 option)

Notes:
Series is rated up to 60 A per power bank.
Some lengths, styles and options are non-standard, non-returnable.
The Molex EXTreme LPHPower™ line is a second source to the Samtec LPH/TPH Series.
*EXTreme LPHPower™ is a trademark of Molex Incorporated.

30 A SIGNAL/POWER COMBO SYSTEM

SERIES	POWER POSITIONS	SIGNAL POSITIONS	PLATING OPTION	TAIL	GP
LPHT Terminal LPHS Socket	Total, 2 per power bank -02, -04, -06, -08, -10	Total -16 -20 -24 -32	-L = 10 μ" (0.25 μm) Gold on contact, Matte Tin on tail	-VP1 = Vertical Press-fit (LPHS only) -RT1 = Right-angle Through-hole (Use with (1.60 mm) .062" thick board) -RT2 = Right-angle Through-hole (Use with (2.36 mm) .093" thick board)	

LPHT
Board Mates:
LPHS



SIGNAL POSITIONS	POWER POSITIONS				
	A (-02)	A (-04)	A (-06)	A (-08)	A (-10)
-16	(33.97) 1.337	(45.97) 1.810	(57.97) 2.282	(69.97) 2.755	(81.97) 3.227
-20	(36.51) 1.437	(48.51) 1.910	(60.51) 2.382	(72.51) 2.855	(84.51) 3.327
-24	(39.05) 1.537	(51.05) 2.010	(63.05) 2.482	(75.05) 2.955	(87.05) 3.427
-32	(44.13) 1.737	(56.13) 2.210	(68.13) 2.682	(80.13) 3.155	(92.13) 3.627

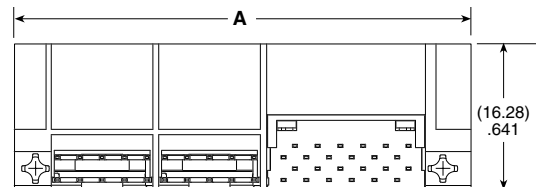
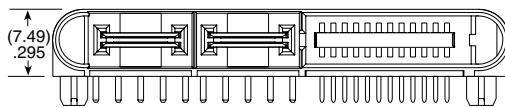

View complete specifications at: samtec.com?LPHT

LPHS
Board Mates:
LPHT



SIGNAL POSITIONS	POWER POSITIONS									
	A (-02)	B (-02)	A (-04)	B (-04)	A (-06)	B (-06)	A (-08)	B (-08)	A (-10)	B (-10)
-16	(31.64) 1.918	(25.88) 1.019	(43.64) 1.718	(37.88) 1.491	(55.64) 2.191	(49.88) 1.964	(67.64) 2.633	(61.88) 2.436	(79.64) 3.135	(73.88) 2.909
-20	(34.18) 1.346	(28.42) 1.119	(46.18) 1.818	(40.42) 1.591	(58.18) 2.291	(52.42) 2.064	(70.18) 2.763	(64.42) 2.536	(82.18) 3.235	(76.42) 3.009
-24	(36.72) 1.446	(30.96) 1.219	(48.72) 1.918	(42.96) 1.691	(60.72) 2.391	(54.96) 2.164	(72.72) 2.863	(66.96) 2.636	(84.72) 3.335	(78.96) 3.109
-32	(41.80) 1.646	(36.04) 1.419	(53.80) 2.118	(48.04) 1.891	(65.80) 2.591	(60.04) 2.364	(78.00) 3.063	(72.04) 2.836	(89.80) 3.535	(84.04) 3.309

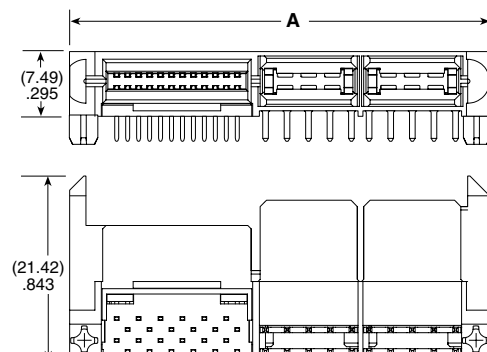
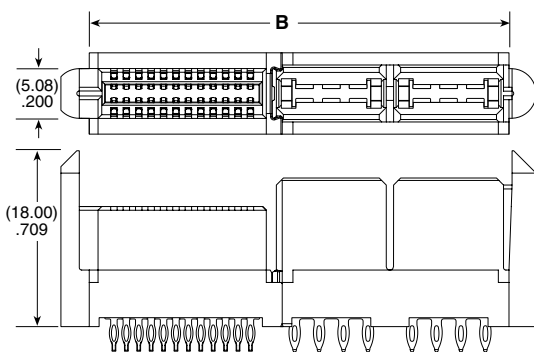

-VP

-RT

View complete specifications at: samtec.com?LPHS

POWER™ EXTreme STRIP Ten60

EXTREME HIGH-POWER 60 A SYSTEMS

FEATURES & BENEFITS

- Up to 60 A per power blade (2 blades powered)
- Low 10 mm profile (right-angle) for enhanced system airflow
- Power only, or power/signal combinations
- 3 or 5 signal rows in the same form factor
- AC power, DC power, power/signal combinations and split power options available
- Coplanar and perpendicular applications
- Modules can be configured to accommodate most any design
- Rugged guide posts are standard; top design for board space savings
- Press-fit (ET60S only) and hot swap (ET60T only) options available

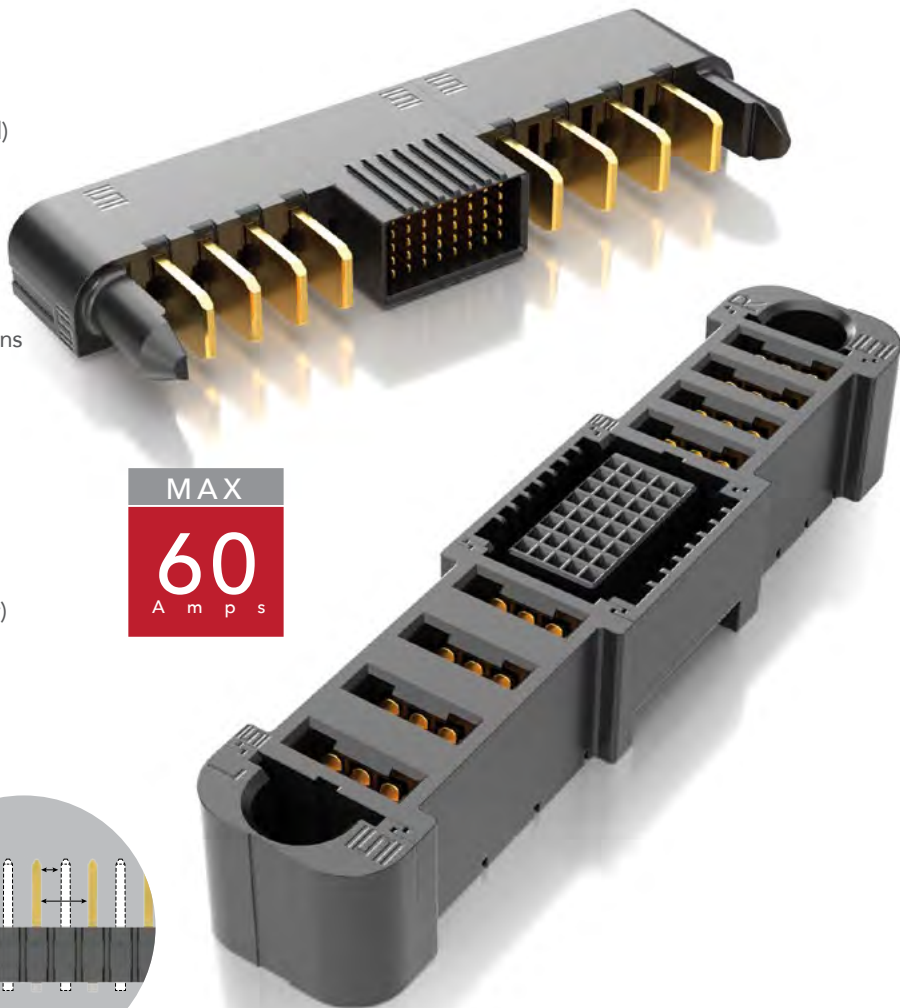

Standard Creepage*	3.02 mm
Standard Clearance*	1.87 mm

*Selectively loading contacts achieves customer specific creepage and clearance requirements. Contact asp@samtec.com

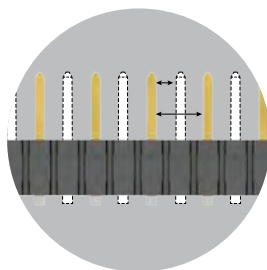

KEY SPECIFICATIONS

	PITCH	INSULATOR MATERIAL	TERMINAL MATERIAL	PLATING	OPERATING TEMP RANGE	VOLTAGE RATING	MATING CYCLES	LEAD-FREE SOLDERABLE
Power	(5.50 mm) .217" (7.50 mm) .295"	Black LCP	Signal: Phosphor Bronze Power: Copper Alloy	Au or Sn over 50 μ" (1.27 μm) Ni	-40 °C to +105 °C	280 VAC	500	Yes
Signal	(2.00 mm) .097" (5 row) (2.54 mm) .100" (3 row)							

Notes:

Some lengths, styles and options are non-standard, non-returnable.
*EXTreme Ten60Power™ is a trademark of Molex Incorporated and is dual sourced by Molex®

60 A SIGNAL/POWER COMBO SYSTEM

SERIES	POWER OPTION (R)	ROWS	SIGNAL POS. PER ROW	POWER OPTION (L)	PLATING	TAIL	GUIDE POST	OPTION
ET60T Terminal	-AXX = AC Power Positions (02 - 06)	-0 = No Signal	-00 = No Signal	-AXX = AC Power Positions (02 - 06)	-L = 10 μ" (0.25 μm) Gold on contact, Matte Tin on tail (Not available for 5 rows)	-VP = Vertical Press-fit	(Required callout)	(Leave blank for no hot swap)
ET60S Socket	-DXX = DC Power Positions (02 - 10)	-3	-08 = 3 Row only	-DXX = DC Power Positions (02 - 10)	-S = 30 μ" (0.76 μm) Gold on contact, Matte tin on tail	-V1 = Vertical through-hole (Use with (1.60 mm) .062" thick card) (-0 and -3 Row only)	-S = Side Guide Post	-H = Hot Swap (ET60T only)
	-SXX* = Split Power	-5	-01, -02, -03, -04, -05, -06, -07, -08 = 5 Row only	-SXX* = Split Power		-R1 = Right-angle through-hole (Use with (1.60 mm) .062" thick card) (required for ET60T)	-T* = Top Guide Post	
	-000 = No Power			-000 = No Power				

*PRELIMINARY

ET60T
Board Mates:
ET60S

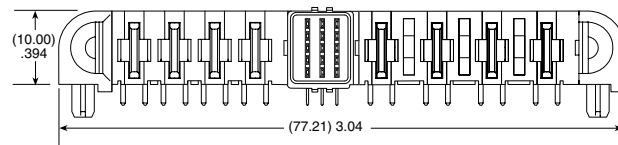
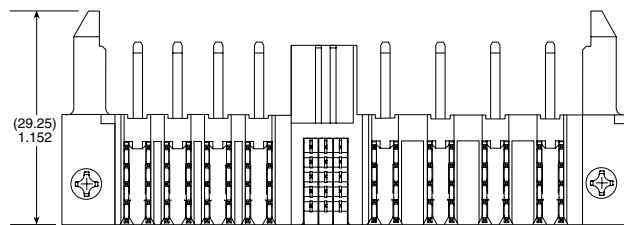
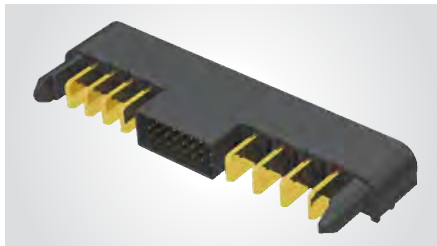

ET60T-D04-5-03-A04-X-R1-S SHOWN

View complete specifications at: samtec.com?ET60T

ET60S
Board Mates:
ET60T

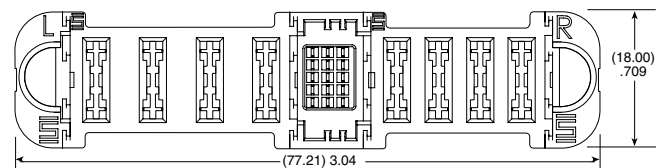
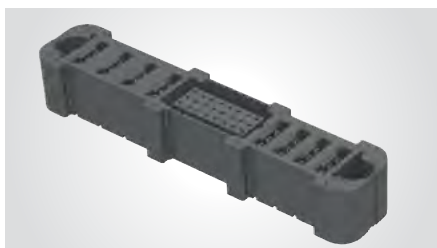

VERTICAL
ET60S-D04-5-03-A04-X-VP-S SHOWN

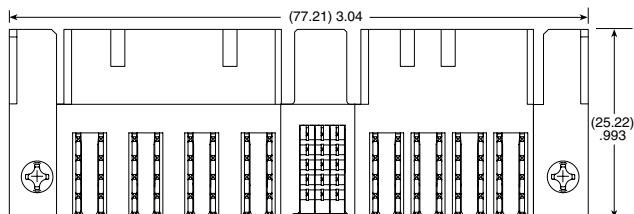
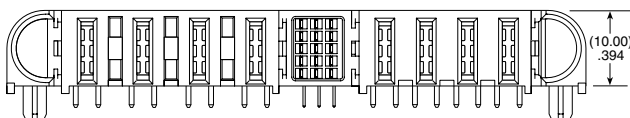

RIGHT-ANGLE
ET60S-D04-5-03-A04-X-R1-S SHOWN

View complete specifications at: samtec.com?ET60S

FLEXIBLE POWER SYSTEMS

FEATURES & BENEFITS

- Board-to-board and discrete wire cable systems
- Power Mate® system with polarized guide posts
- Mini Mate® system with reliable Tiger Buy™ contacts
- Individually shrouded contacts
- Elevated stack heights
- Optional polarization
- Vertical and right-angle for parallel, perpendicular and coplanar applications
- Rugged metal or plastic latching systems
- Cable components and tooling available

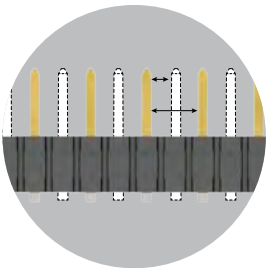

Selectively loading contacts achieves customer specific creepage and clearance requirements.

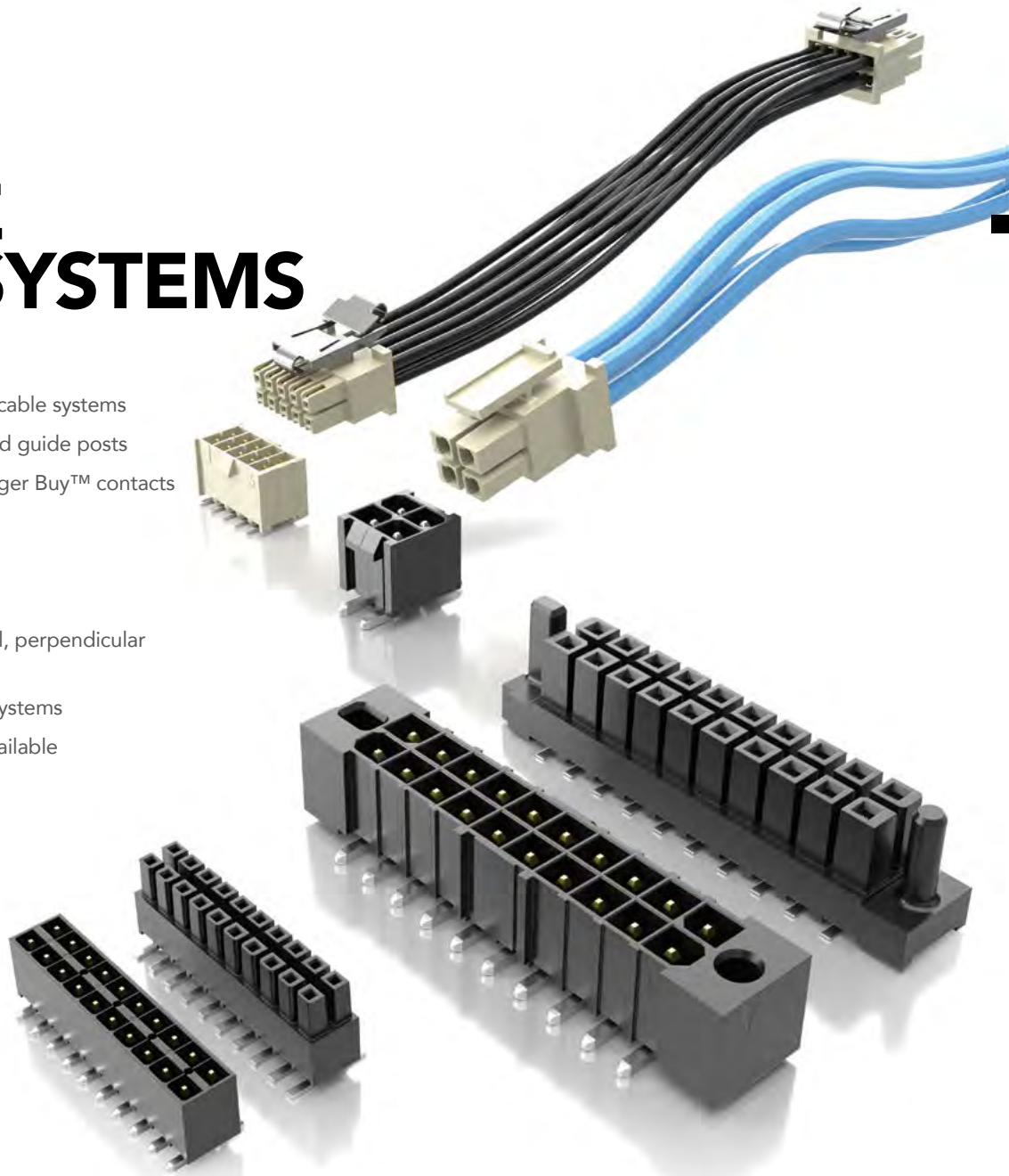

KEY SPECIFICATIONS

SERIES	IPT1/IP51	IPBT/IPBS	HPM/HPW/HPF	FWJ/HFWJ/FHP
PITCH	(2.54 mm) .100"	(4.19 mm) .165"	(5.08 mm) .200"	(3.96 mm) .156"
CCC (1 PIN)*	5.9 A	10.3 A /pin (2 pins powered)	16.6 A	13.1 A
CCC (2 PINS)*	4.8 A	8.4 A/pin (4 pins powered)	14.4 A	11.2 A
CCC (3 PINS)*	4.1 A	7.6 A/pin (6 pins powered)	13.2 A	10.3 A
CREEPAGE	(2.54 mm) .100"	(4.27 mm) .168"	(3.94 mm) .155"	(3.92 mm) .154"
CLEARANCE	(1.91 mm) .075"	(3.05 mm) .120"	(3.94 mm) .155"	(2.82 mm) .111"
VAC	775	400	850	600
VDC	1095	565	1200	845
CYCLES	1000 (MFG Tested)	100	100	100

(2.54 mm) .100" PITCH • SHROUDED POWER CONNECTOR SET

IPT1	1	NO. PINS PER ROW	LEAD STYLE	PLATING OPTION	D	TAIL OPTION	OTHER OPTIONS
		05 10 15 20 25 (Standard Sizes)	Specify LEAD STYLE from chart	-L = 10 μ" (0.25 μm) Gold on contact, Matte Tin on tail		Requires -01 Lead Style (Leave blank for Through-hole) -RA = Right-angle -VS = Surface Mount	-A = Alignment Pin (-VS only) (N/A with -LC) -LC = Locking Clip (Manual placement required) (-VS only) (N/A with -A) -K = (6.00 mm) .236" DIA Polyimide film Pick & Place Pad (-VS only) -TR = Tape & Reel (-VS only) -FR = Full Reel Tape & Reel (must order max. quantity per reel; contact Samtec for quantity breaks) (-VS only)

IPT1
Board Mates:
IPS1

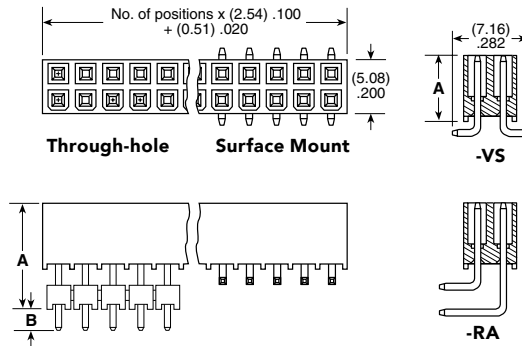

LEAD STYLE	MATED HEIGHT	A	B
-01	(11.05) .435	(6.35) .250	(2.16) .085
-01-VS	(13.59) .535	(6.35) .250	N/A
-02	(14.00) .551	(9.30) .366	(2.64) .104
-03	(16.00) .630	(11.30) .445	(2.16) .085
-04	(17.00) .669	(12.30) .484	(2.69) .106
-05	(19.00) .748	(14.30) .563	(2.46) .097
-06	(20.00) .787	(15.30) .602	(2.35) .093
-07	(25.00) .984	(20.30) .799	(2.31) .091
-08	(30.00) 1.181	(25.30) .996	(2.39) .094
-09	(35.00) 1.378	(30.30) 1.193	(2.46) .097

IPS1	1	NO. PINS PER ROW	01	PLATING OPTION	D	TAIL OPTION	OTHER OPTIONS
		05 10 15 20 25 (Standard Sizes)		-L = 10 μ" (0.25 μm) Gold on contact, Matte Tin on tail		Leave blank for Through-hole -RA = Right-angle -VS = Surface Mount	-LC = Locking Clip (Manual placement required) (-VS only) -K = (5.50 mm) .217" DIA Polyimide film Pick & Place Pad (-VS only) -TR = Tape & Reel (-VS only) -FR = Full Reel Tape & Reel (must order max. quantity per reel; contact Samtec for quantity breaks) (-VS only)

IPS1
Board Mates:
IPT1

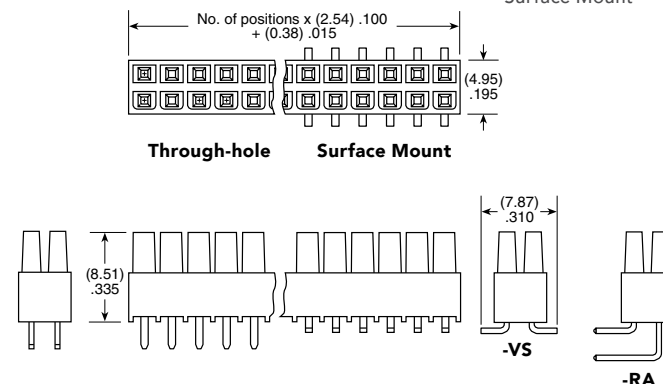
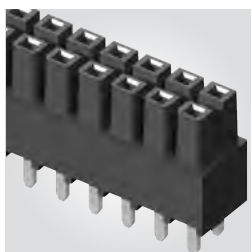

Note:
Some lengths, styles and options are non-standard, non-returnable.

View complete specifications at: samtec.com?IPT1 & samtec.com?IPS1

(2.54 mm) .100" PITCH • DISCRETE WIRE TERMINAL

IPL1	1	PINS PER ROW	LEAD STYLE	PLATING OPTION	ROW OPTION	TAIL OPTION	K	OPTION
		02, 03, 04, 05, 06, 08, 10, 12, 15, 16, 20, 25 (Standard sizes)	-01 = Through-hole -02 = Surface Mount	-L = 10 μ" (0.25 μm) Gold on contact, Matte Tin on tail	-S = Single Row -SH = Single Row Horizontal (-02 lead style only) -D = Double Row	-RA = Right-angle (-01 lead style only) -RE1 = Right-angle Elevated (-01 lead style only) (-K is a required callout)	-K = Keyed Polarization	-TR = Tape & Reel (-02 lead style only) Comes with Polyimide Pick & Place Pad -FR = Full Reel Tape & Reel (must order max. quantity per reel; contact Samtec for quantity breaks) (-02 lead style only) Comes with Polyimide Pick & Place Pad

IPL1

Cable Mates:
MMSD, MMSS,
MMSDT, MMSST

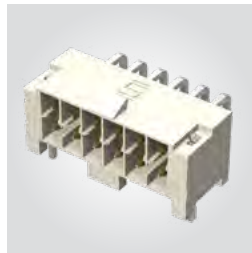

MMSD/IPL1	
WIRE GAUGE	CURRENT RATING (PER PIN)
20	4.8 A
22	4.3 A
24	3.9 A
26	3.5 A
28	2.6 A
30	2.1 A

2 PINS POWERED

SPECIFICATIONS

Insulator Material:
Natural LCP
Terminal Material:
Phosphor Bronze
Plating:
Sn or Au over
50 μ" (1.27 μm) Ni
Operating Temp Range:
-55 °C to +125 °C
Voltage Rating:
675 VAC/954 VDC

PROCESSING

Lead-Free Solderable:
Yes
-S & -D (-02 Lead Style)
SMT Lead Coplanarity:
(0.10 mm) .004" max (02-05)
(0.13 mm) .005" max (06-10)*
(0.15 mm) .006" max (11-25)*
*(.004" stencil solution may be available; contact IPG@samtec.com)
-SH SMT Lead Coplanarity:
(0.15 mm) .006" max (02-25)*
*(.004" stencil solution may be available; contact IPG@samtec.com)

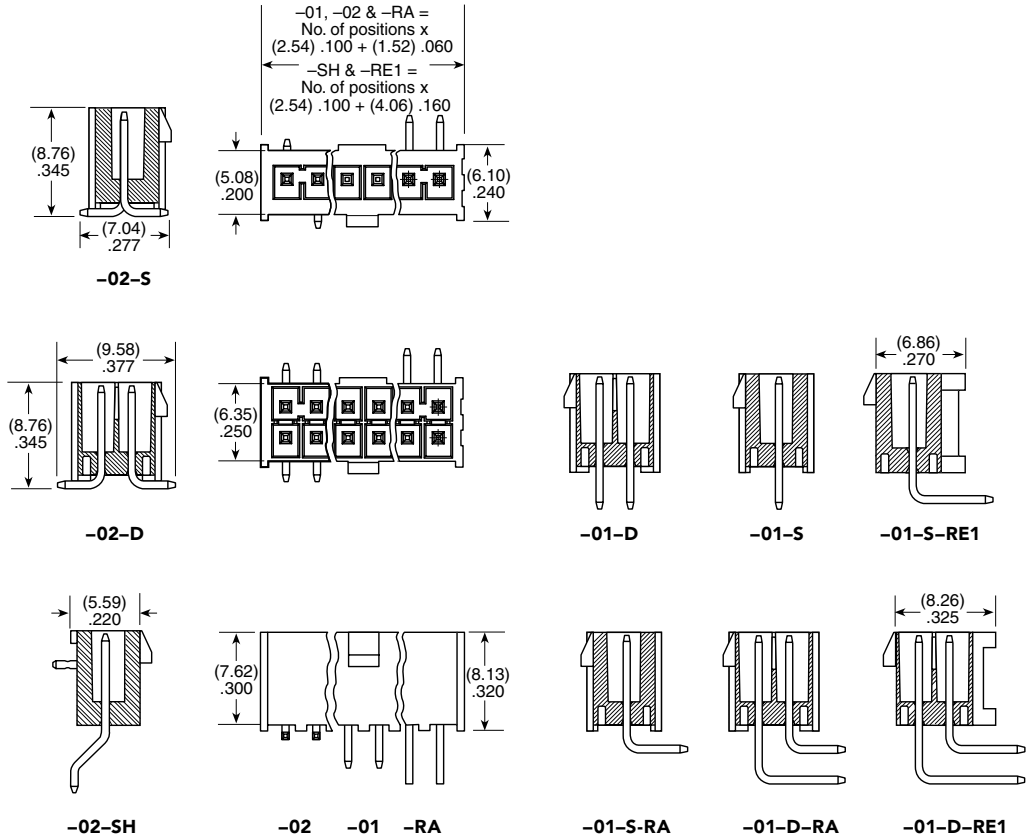

ALSO AVAILABLE
MOQ Required

Other sizes
With or without plug polarization
Guide post holes
Other platings
Weld tab

Note:
Some lengths, styles and options are non-standard, non-returnable.

View complete specifications at: samtec.com?IPL1



SERIES	PINS PER ROW	WIRE GAUGE	PLATING OPTION	ASSEMBLY LENGTH	END OPTION	K	LATCH OPTION
MMSD = Double Row PVC Cable	-02, -03, -04, -05,	-20 -20C = Color Coded Cable (MMSD & MMSS only)	-L = 10 μ" (0.25 μm) Gold on contact, Tin on tail	-“XX.XX” = Assembly Length in Inches (82.55 mm) 03.25" min.	-S = Single Ended	-K = Keyed Polarization	(Metal latches for more rugged environments; -02, -05 & -10 positions only)
MMSDT = Double Row Blue *Teflon® Cable (20, 24, 28, 30 AWG only)	-06, -08, -10, -12,	-22, -24			-D = Double Ended (Latch Required)		-M = Single Ended, Metal Latches (Leave blank for plastic)
MMSS = Single Row PVC Cable	-15, -16, -20, -25 (Standard sizes)	-24C = Color Coded Cable (MMSD & MMSS only)					Double Ended (-D) Crossed requires MMSD/MMSDT
MMSST = Single Row Blue *Teflon® Cable (20, 24, 28, 30 AWG only)		-26, -28					-LUS = Plastic Latch up, straight
MMSD, MMSDT, MMSS, MMSST Board Mates: IPL1 (Does not mate with IPT1)		-28C = Color Coded Cable (MMSD & MMSS only)					-LDS = Plastic Latch down, straight
Cable Mates: MMTD(T), MMTS(T)		-30					-LUX = Plastic Latch up, crossed
* Dupont™ Teflon® is a registered trademark of E.I. du Pont de Nemours and Company or its affiliates. Teflon® cable is intended for crimp only. Contact Samtec for solderable cable applications.							-LDX = Plastic Latch down, crossed
							-MUS = Metal Latch up, straight
							-MDS = Metal Latch down, straight
							-MUX = Metal Latch up, crossed
							-MDX = Metal Latch down, crossed

**-20C, -24C, -28C
CABLE COLOR CODING**

PIN	COLOR
1	BROWN
2	RED
3	ORANGE
4	YELLOW
5	GREEN
6	BLUE
7	VIOLET
8	GRAY
9	WHITE
10	BLACK
ETC	REPEAT

View complete specifications at: samtec.com?MMSD, samtec.com?MMSDT, samtec.com?MMSS & samtec.com?MMSST

IPD1	POSITIONS PER ROW	ROW OPTION	K	LATCH OPTION	SERIES	WIRE GAUGE	01	PLATING OPTION
	-02, -03, -04, -05, -06, -08, -10, -12, -15, -16, -20, -25 (Standard sizes)	-S = Single Row -D = Double Row	-K = Keyed Polarization	-M = Metal Latch (Metal for more rugged environments) (-02, -05 & -10 positions only) (Leave blank for plastic latch)	CC79L = Contact, Loose	-2630 = 26 to 30 AWG		-L = 10 μ" (0.25 μm) Gold on contact, Tin on tail
					CC79R = Contact, Full Reel (12,000 Parts per Reel)	-2024 = 20 to 24 AWG		

TOOLING

Hand Tool: CAT-HT-179-2030-13 (20-30 AWG)

Mini Applicator: CAT-MC-179-2024-XX-01 (20-24 AWG)

Mini Applicator: CAT-MC-179-2630 XX-01 (26-30 AWG)

Extraction Tool: CAT-EX-179-01

Not:
Some lengths, styles and
options are non-standard,
non-returnable.

View complete specifications at: samtec.com?IPD1, samtec.com?CC79L & samtec.com?CC79R

(4.19 mm) .165" PITCH • ISOLATED POWER CONNECTOR SET

IPBT	1	NO. OF POSITIONS PER ROW	LEAD STYLE	PLATING OPTION	ROW OPTION	OPTIONS
		02, 03, 04, 05, 08, 10 15 (-D Only) (Standard Sizes)	-H1 = Through-hole -H2 = Surface Mount	-T = Matte Tin	-S = Single Row -D = Double Row	-RA = Right-angle (Lead Style -H1 only) -GP = Guide Post Holes (Not available with -K) -K = Keyed Polarization (not available with -GP option, is required callout if -GP not called out)

IPBT
Board Mates:
IPBS
Cable Mates:
PMSD, PMSS

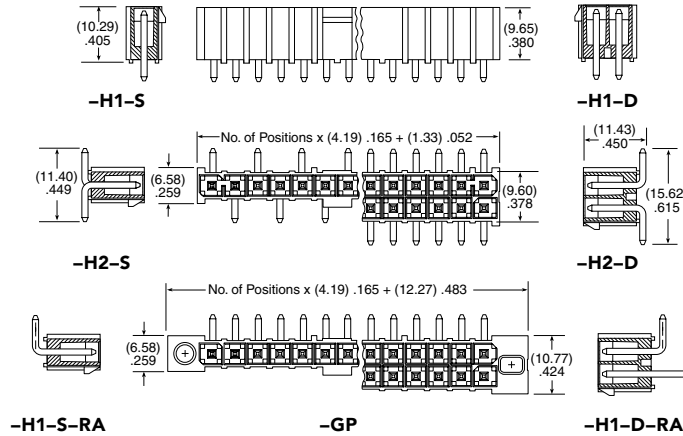
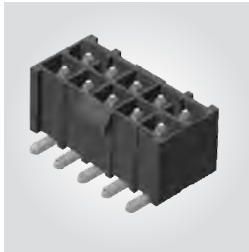

IPBT/IPBS	
PINS POWERED	CURRENT RATING (PER CONTACT)
2	10.3 A
4	8.4 A
6	7.6 A
8	7.1 A
30	6.0 A

IPBS	1	NO. OF POSITIONS PER ROW	LEAD STYLE	PLATING OPTION	ROW OPTION	OPTION
		02, 03, 04, 05, 08, 10 15 (-D Only) (Standard Sizes)	-01 = Standard Power -02 = Standard Power Surface Mount	-T = Matte Tin	-S = Single Row -D = Double Row	-GP = Guide Post

IPBS
Board Mates:
IPBT

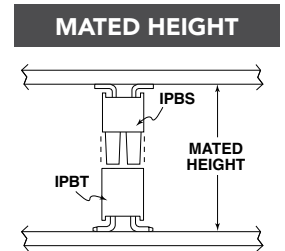
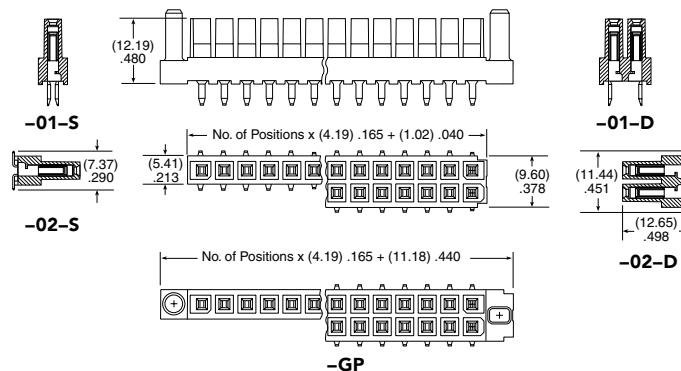
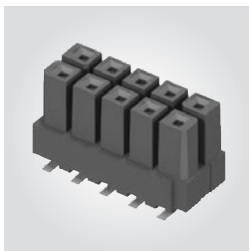

IPBT/IPBS LEAD STYLE	MATED HEIGHT*
H1/-01	(15.25) .600
-H2/-02	(16.84) .663

Note:
Some lengths, styles and options are non-standard, non-returnable.

*Processing conditions will affect mated height.

View complete specifications at: samtec.com?IPBT & samtec.com?IPBS



(4.19 mm) .165" PITCH • DISCRETE WIRE CABLE & COMPONENTS

SERIES	PINS PER ROW	WIRE GAUGE	K	ASSEMBLED LENGTH	END OPTION	LATCH OPTION
PMSD = Double Row PVC Cable	-02, -03	-16	-K = Keyed Polarization	-"XX.XX" = Wire length in inches (88.90 mm) 03.50" min.	-S = Single End	-LUS = Plastic Latch up, straight
PMSDT = Double Row Blue *Teflon® Cable (24 AWG only)	-04, -05	-18			-D = Double End (Latch Required)	-LDS = Plastic Latch down, straight
PMSS = Single Row PVC Cable	-08, -10	-206 (20 AWG/600 volts)				-LUX* = Plastic Latch up, crossed
PMSST = Single Row Blue *Teflon® Cable (24 AWG only)	-15* (Standard sizes) *Only available for double row	-22				-LDX* = Plastic Latch down, crossed *(PMSD/PMSDT only)
		-24				

PMSD, PMSDT, PMSS, PMSST Board Mates:

IPBT

*DuPont™ Teflon® is a registered trademark of the E.I. du Pont de Nemours and Company or its affiliates.

Notes:
Teflon® cable is intended for crimp only. Contact Samtec for solderable cable applications.

For wiring option information refer to drawing on web.

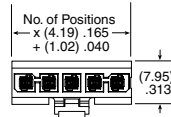

PMS/PMSST

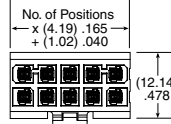

PMSD/PMSDT

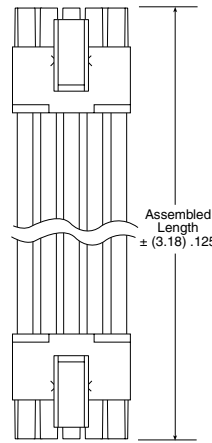

PMSD/IPBT	
WIRE GAUGE	CURRENT RATING (PER PIN)
16 AWG	10.3 A
18 AWG	8.8 A
22 AWG	5.7 A
24 AWG	5.2 A

2 PIN POWERED

View complete specifications at: samtec.com?PMSD, samtec.com?PMSDT, samtec.com?PMSS & samtec.com?PMSST

IPBD	POSITIONS PER ROW	ROW OPTION	K	SERIES	WIRE GAUGE	01	T	SP
	-02, -03, -04, -05, -08, -10, -15 (Standard sizes)	-S = Single Row -D = Double Row	-K = Keyed Polarization	CC69L = Contact, Loose CC69R = Contact, Full Reel (4,000 Parts per Reel)	-2024 = 20 to 24 AWG -1620 = 16 to 20 AWG		-T = Tin	

TOOLING

Hand Tool: CAT-HT-169-1620-13 (16-20 AWG)
Hand Tool: CAT-HT-169-2024-13 (20-24 AWG)

Mini Applicator: CAT-MC-169-1620-XX-01 (16-20 AWG)
Mini Applicator: CAT-MC-169-2024-XX-01 (20-24 AWG)
Extraction Tool: CAT-EX-169-01

Note:
Some lengths, styles and options are non-standard, non-returnable.

View complete specifications at: samtec.com?IPBD, samtec.com?CC69L & samtec.com?CC69R

POWER HEADERS, STACKERS & SOCKETS

MAX
13.1
A m p s

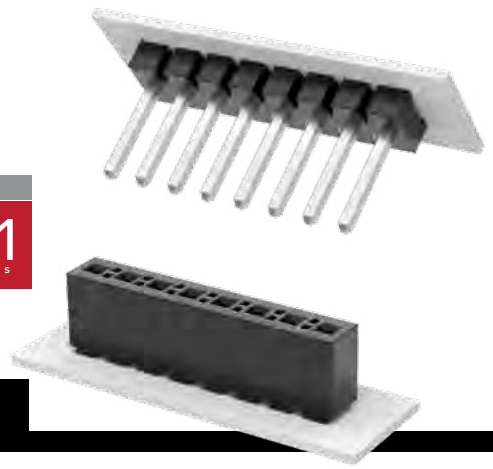

(3.96 mm) .156" PITCH • FWJ, HFWJ, JW, FHP SERIES

FWJ, HFWJ, JW
Board Mates:
FHP

FHP
Board Mates:
FWJ, HFWJ, JW

SPECIFICATIONS

Insulator Material:
FWJ = Black Glass Filled Polyester
HFWJ, JW = Natural Liquid Crystal Polymer
FHP = Black LCP

Terminal Material (FWJ, HFWJ, JW):
Phosphor Bronze

Contact Material (FHP):
BeCu

Plating:
Sn over 50 μ " (1.27 μ m) Ni

Operating Temp Range:
-55 °C to +105 °C

Voltage Rating:
600 VAC/845 VDC

Insertion Depth (FHP):
(3.57 mm) .140" to (8.76 mm) .345" or pass-through from top

Wiping Distance (FHP):
(0.38 mm) .015"

PROCESSING

Lead-Free Solderable:
FWJ = No, Lead Wave only
HFWJ, JW, FHP = Yes

SMT Lead Coplanarity:
HFWJ, FWJ, JW = (0.20 mm) .008" max (02-16)*
(0.25 mm) .010" max (17-24)*
FHP = (0.15 mm) .006" max*
*(.004" stencil solution may be available; contact ipg@samtec.com)

SERIES	NO. OF PINS	LEAD STYLE	PLATING OPTION	S	OTHER OPTIONS
--------	-------------	------------	----------------	---	---------------

FWJ
Standard Header

HFWJ
High Temp Header

01 thru 24

Specify LEAD STYLE from chart below

-T = Matte Tin

Leave blank for Through-hole

-RA = Right-angle (Style -02 & -04 only)

-VS = Surface Mount Requires HFWJ (2 pins/row minimum) Style -05 not available.

-P = Pick & Place Pad (3 Pos. min.) (6.98 mm) .275" min. post height (-VS only)

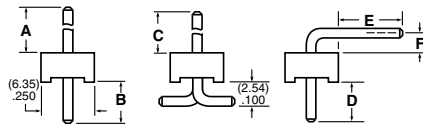
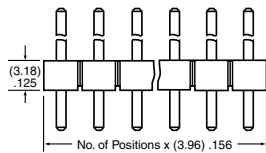

LEAD STYLE	A	B	C	D	E	F
-01	(11.43) .450	(4.45) .175	(10.46) .412	-	-	-
-02	(12.70) .500	(11.73) .462	(4.45) .175	(8.13) .320	(2.54) .100	
-04	(20.55) .809	(3.96) .156	(19.10) .752	(3.96) .156	(13.56) .534	(4.95) .195
-05*	(3.81) .150	(12.07) .475	-	-	-	-

*FWJ Only

JW	NO. OF PINS	04	PLATING OPTION	S	STACK HEIGHT	POST HEIGHT	OTHER OPTIONS
----	-------------	----	----------------	---	--------------	-------------	---------------

02 thru 24

-T = Matte Tin

-“XXX” = Stacker Height (in inches) (0.13 mm) .005" increments

-“XXX” = Post Height (in inches)

Leave blank for Through-hole

-VS = Surface Mount (2 pins/row minimum)

-P = Pick & Place Pad (3 Pos. min.) (6.98 mm) .275" min. post height (-VS only)

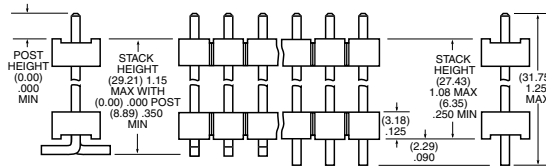

FHP	NO. OF PINS	LEAD STYLE	PLATING OPTION	S	OTHER OPTIONS
-----	-------------	------------	----------------	---	---------------

02 thru 24

-01 = Through-hole

-T = Matte Tin

-02 = Surface Mount

-LC = Locking Clip (Manual placement required) (-02 lead style only)

-TR = Tape & Reel Packaging (Available on positions 2-18) (-02 lead style only)

-K = (6.50 mm) .256" DIA Polyimide film Pick & Place Pad (2-4 positions require -“X”R) (-02 lead style only)

-FR = Full Reel Tape & Reel (must order max. quantity per reel; contact Samtec for quantity breaks) (Available on positions 2-18) (-02 lead style only)

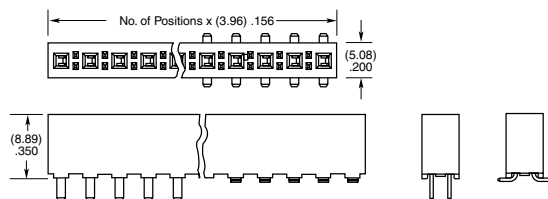

Note:
Some lengths, styles and options are non-standard, non-returnable.

POWER HEADERS, STACKERS & SOCKETS

MAX
16.1
A m p s

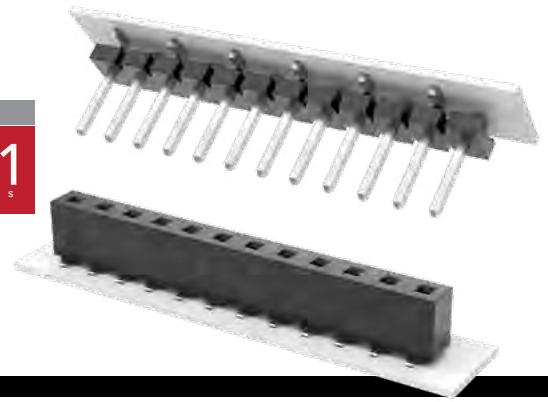

(5.08 mm) .200" PITCH • HPM, HPW, HPF SERIES

HPM, HPW
Board Mates:
HPF

HPF
Board Mates:
HPM, HPW

SPECIFICATIONS

Insulator Material:
HPW/HPM = Glass Filled Polyester (Through-hole), Natural Liquid Crystal Polymer (Surface Mount)
HPF = Black LCP
Terminal Material (HPM/HPW):
Copper Alloy
Contact Material (HPF):
BeCu
Plating:
Sn over 50 μ " (1.27 μ m) Ni
Operating Temp Range:
-55 °C to +105 °C
Voltage Rating:
HPM/HPF = 850 VAC/1200 VDC
Insertion Depth (HPF):
(3.68 mm) .145" to (8.26 mm) .325" (.368" (9.35 mm) plus board thickness minimum for bottom entry)
Wiping Distance (HPF):
(0.38 mm) .015"

PROCESSING

Lead-Free Solderable:
HPW-VS, HPM-VS, HPF = Yes
HPM -TH, HPM -RA & HPW -TH = No, Lead Wave only
SMT Lead Coplanarity:
HPM = (0.20 mm) .008" max (02-15)*
HPM = (0.25 mm) .010" max (16-20)*
HPW = (0.20 mm) .008" max*
HPF = (0.15 mm) .006" max (02-10)*
HPF = (0.20 mm) .008" max (11-20)*
*(.004" stencil solution may be available; contact ipg@samtec.com)

Note:
Some lengths, styles and options are non-standard, non-returnable.

HPM	NO. OF PINS	LEAD STYLE	PLATING OPTION	S	TAIL OPTION	OTHER OPTION
High Temp High Power Header	01 thru 20	Specify LEAD STYLE from chart below	-T = Matte Tin		Leave blank for Through-hole -RA = Right-angle (-02 & -04 lead style only) -VS = Surface Mount (2 pins/row minimum) (-01 & -02 lead style only)	-P = Pick & Place Pad (3 Pos. min.) (-VS only) (Not Available with -05 lead style)

LEAD STYLE	A	B	C	D	E	F	G
-01	(4.57) .180	(11.94) .470	-	-	-	(10.72) .422	(8.64) .340
-02	(4.57) .180	(13.21) .520	(2.54) .100	(4.57) .180	(8.08) .318	(12.24) .482	(8.38) .330
-04	(4.09) .161	(21.06) .829	(4.95) .195	(3.96) .156	(13.82) .544	-	-
-05	(4.57) .180	(3.81) .150	-	-	-	-	-

HPW	NO. OF PINS	LEAD STYLE	PLATING OPTION	S	STACK HEIGHT	POST HEIGHT	OTHER OPTIONS
High Temp High Power	02 thru 20		-T = Matte Tin		- "XXX" = Stacker Height (in inches) (0.13 mm) .005" increments	- "XXX" = Post Height (in inches)	Leave blank for Through-hole -VS = Surface Mount (2 pins/row minimum) -P = Pick & Place Pad (3 Pos. min.) (6.98 mm) .275" min. post height (-VS only)

HPF	NO. OF PINS	LEAD STYLE	PLATING OPTION	S	OTHER OPTIONS
	02 thru 20	-01 = Through-hole -02 = Surface Mount	-T = Matte Tin		-LC = Locking Clip (Manual placement required) (-02 lead style only) -TR = Tape & Reel Packaging (14 positions max.) (Style -02 only) -FR = Full Reel Tape & Reel (must order max. quantity per reel; contact Samtec for quantity breaks) (14 positions max.) (Style -02 only) -K = (6.50 mm) .256" DIA Polyimide film Pick & Place Pad

ACCLIMATE™

FLEXIBLE SEALED CIRCULAR SYSTEMS



FEATURES & BENEFITS

- Metal or plastic, 12 mm, 16 mm and 22 mm shells
- Choice of pin configuration and gender
- Bayonet-style latching systems meet IP68 requirements
- Cost-effective crimp version available (samtec.com/crimp)
- Variety of end 2 options for panel-to-board applications
- Mini push-pull latching system meets IP67 requirements for dust and waterproof sealing



Kitted components for efficient field assembly



Dust caps available

ACX-12

MAX

5.0
A m p s

No. of Pins
2, 4, 5

ACX-16

MAX

11.6
A m p s

No. of Pins
2, 10, 14

ACX-22

MAX

8.3
A m p s

No. of Pins
8, 20, 30

KEY SPECIFICATIONS

INSULATOR MATERIAL	TERMINAL MATERIAL	CONTACT MATERIAL	OPERATING TEMP RANGE	HOUSING
Thermoplastic	Brass	Brass/BeCu	-10 °C to +80 °C (ACX-12) -10 °C to +105 °C (ACX-16) -10 °C to +105 °C (ACX-22)	Thermoplastic (-P) Zinc Alloy (-M)

12 mm • IP68 SEALED CABLE ASSEMBLY

SERIES	12	LEAD STYLE	PLATING OPTION	LENGTH	END 1	END 2	HOUSING MATERIAL	KEYING OPTIONS
ACP Terminal		-01 = 1.0 mm DIA (4) terminals or sockets (24 AWG)	-G = 10 μ" (0.25 μm) Gold over 50 μ" (1.27 μm) Ni on contact	-"XX.XX" = Length in meters (00.25 m min. to 50.00 m max.) Standard lengths	-T = Terminal	-T = Terminal (ACP only)	-P = Plastic	-1 = Orange, 45°
ACR Socket		-02 = 1.0 mm DIA (5) terminals or sockets (24 AWG)			-S = Socket (N/A with End 2 -T)	-S = Socket (ACP only)	-M = Metal	
		-05 = 1.0 mm DIA (2) terminals or sockets (24 AWG) + 0.5 mm DIA (4) terminals or sockets (28 AWG)				-BC = Blunt Cut		
						-S1 = Connector determine by lead style. See chart for end 2 connector used. (ACR only)		

ACP-12
End 1/2 Mates:
ACP-12
ACR-12
ACRK-12

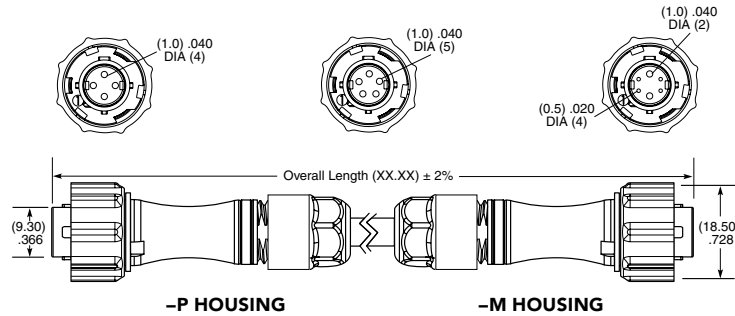

View complete specifications at: samtec.com?ACP-12

ACR-12
End 1 Mates:
ACP-12
ACPK-12
End 2 Mates:
IPL1

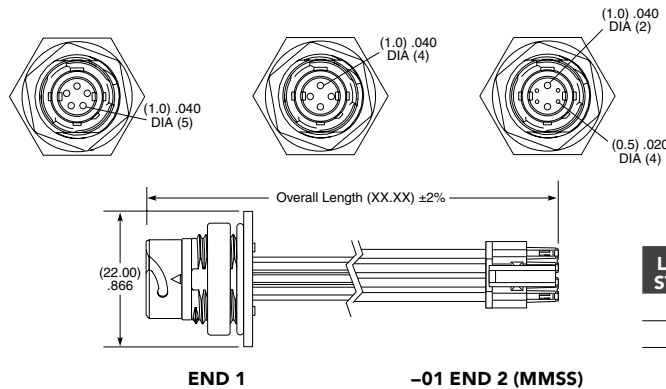

PANEL OPENING

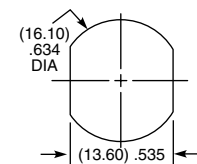

LEAD STYLE	-S1 END 2	MATES WITH -S1
-01	MMSS (24 AWG)	IPL1
-02	MMSS (24 AWG)	
-05	MMSS (24 AWG (2x), 28 AWG (4x))	

View complete specifications at: samtec.com?ACR-12

CURRENT RATING

LEAD STYLE	PINS POWERED	CCC per PIN
-01	4	3.8 A
-02	5	3.6 A
-05	2 (plus 4 signal pins powered @ 1.2 A)	5.0 A

For general reference only. Contact AccliMate@samtec.com for applications requiring higher current carrying capacity.

Note:
Some lengths, styles and options are non-standard, non-returnable.

KITS AVAILABLE

www.samtec.com?ACPK-12
www.samtec.com?ACRK-12

ACCLIMATE™

16 mm • IP68 SEALED CABLE ASSEMBLY

SERIES	16	LEAD STYLE	PLATING OPTION	LENGTH	END 1	END 2	HOUSING MATERIAL	KEYING OPTIONS
ACP Terminal		-01 = 0.5 mm DIA (14) terminals or sockets (28 AWG)	-G = 10 μ" (0.25 μm) Gold over 50 μ" (1.27 μm) Ni on contact	-"XX.XX" = Length in meters (00.25 m min. to 50.00 m max.) Standard lengths	-T = Terminal	-T = Terminal (ACP only)	-P = Plastic	-1 = Orange, 45°
ACR Socket		-02 = 1.0 mm DIA (10) terminals or sockets (24 AWG)			-S = Socket (N/A with End 2 -T)	-S = Socket (ACP only)	-M = Metal	
		-06 = 1.5 mm DIA (2) terminals or sockets (16 AWG) + 0.5 mm DIA (8) terminals or sockets (28 AWG)				-BC = Blunt Cut		
						-S1 = Connector determine by lead style. See chart for end 2 connector used. (ACR only)		

ACP-16

End 1/2 Mates:

ACP-16
ACR-16
ACRK-16

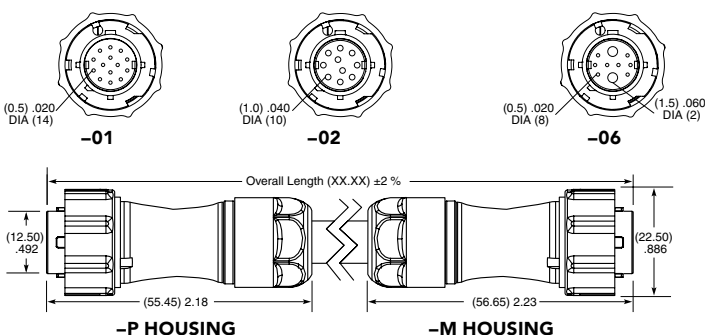

View complete specifications at: samtec.com?ACP-16

ACR-16

End 1 Mates:

ACP-16
ACPK-16

End 2 Mates:

TFM, IPL1, MPT

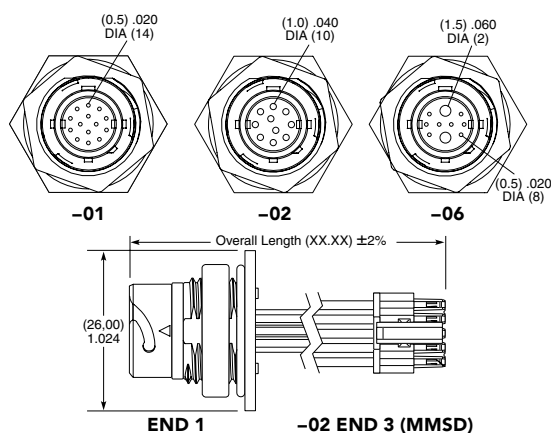

PANEL OPENING

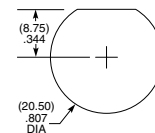

LEAD STYLE	-S1 END 2	MATES WITH -S1
-01	SFSD (28 AWG)	TFM
-02	MMSD (24 AWG)	IPL1
-06	1 x SFSD (28 AWG)	TFM
	1 x MPSS (16 AWG)	MPT

View complete specifications at: samtec.com?ACR-16

CURRENT RATING

LEAD STYLE	PINS POWERED	CCC per PIN
-01	14	1.3 A
-02	10	2.6 A
-06	2 (plus 8 signal pins powered @ 1 A)	11.6 A

For general reference only. Contact AccliMate@samtec.com for applications requiring higher current carrying capacity.

KITS AVAILABLE

www.samtec.com?ACPK-16

www.samtec.com?ACRK-16

Note:
Some lengths, styles and options are non-standard, non-returnable.

22 mm • IP68 SEALED CABLE ASSEMBLY

SERIES	22	LEAD STYLE	PLATING OPTION	LENGTH	END 1	END 2	HOUSING MATERIAL	KEYING OPTIONS
ACP Terminal		-01 = 1.0 mm DIA (30) terminals or sockets (24 AWG)	-G = 10 μ" (0.25 μm) Gold over 50 μ" (1.27 μm) Ni on contact	-"XX.XX" = Length in meters (00.25 m min. to 50.00 m max.) Standard lengths	-T = Terminal	-T = Terminal (ACP only)	-P = Plastic	-1 = Orange, 45°
ACR Socket		-02 = 1.0 mm DIA (20) terminals or sockets (24 AWG)			-S = Socket	-S = Socket (ACP only)	-M = Metal	
		-03 = 1.5 mm DIA (8) terminals or sockets (16 AWG)				-BC = Blunt Cut		
						-S1 = Connector determine by lead style. See chart for end 2 connector used. (ACR only)		

ACP-22
End 1/2 Mates:
ACP-22
ACR-22
ACRK-22

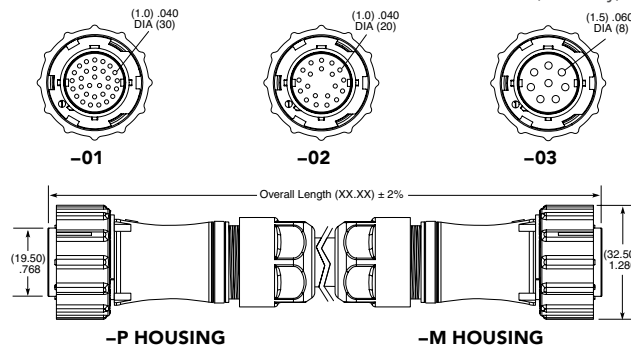

View complete specifications at: samtec.com?ACP-22

ACR-22
End 1 Mates:
ACP-22
ACPK-22
End 2 Mates:
IPL1, MPT

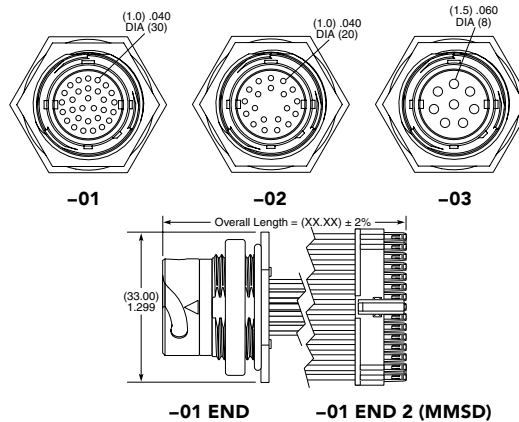

View complete specifications at: samtec.com?ACR-22

PANEL OPENING

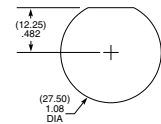

LEAD STYLE	-S1 END 2	MATES WITH -S1
-01	MMSD (24 AWG)	IPL1
-02	MPSS (16 AWG)	MPT

CURRENT RATING		
LEAD STYLE	PINS POWERED	CCC per PIN
-01	30	2.0 A
-02	20	2.3 A
-03	8	8.3 A

For general reference only. Contact AccliMate@samtec.com for applications requiring higher current carrying capacity.

KITS AVAILABLE

www.samtec.com?ACPK-22
www.samtec.com?ACRK-22

Note:
Some lengths, styles and options are non-standard, non-returnable.

IP67 SEALED 8 SERIES CABLE ASSEMBLY



MCP/MCR SERIES

MCP

Mates with:
MCR(K), MCP(K)

MCP Kit:
MCPK

MCR

Mates with:
MCP(K)

MCR Kit:
MCRK

MCP	8	LEAD STYLE	PLATING OPTION	LENGTH	END 1 OPTION	END 2 OPTION
		-02 = 12 positions, 28 AWG	-L = 10 μ" (0.25 μm) Gold on contact area	-01.00 = 1 meter -02.00 = 2 meters Standard lengths	-T = Terminal -S = Socket (Not available with End 2 -T)	-T = Terminal -S = Socket -BC = Blunt Cut

SPECIFICATIONS

Insulator Material:
PPS

Terminal Material:
Phosphor Bronze (MCR)

Contact Material:
Phosphor Bronze (MCR)

Operating Temp Range:
-20 °C to +80 °C

Gasket Material:
Silicone (MCP)
Neoprene Rubber (MCR)

Spring Material:
Stainless Steel (MCP)

Coupling Ring Spacer:
PBT (MCP)

Cable Clamp:
POM (MCP)

Lock Washer:
Phosphor Bronze,
Ni plated (MCR)

Hex Nut:
Brass, Ni plated (MCR)

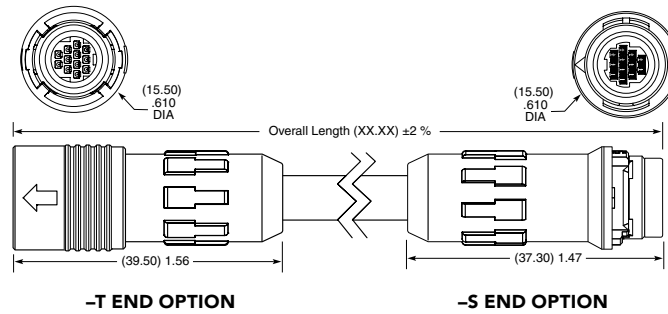

PANEL OPENING

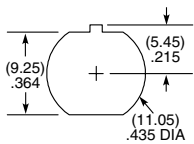

MCR	8	LEAD STYLE	PLATING OPTION	LENGTH	END 1 OPTION	END 2 OPTION
		-02 = 12 positions, 28 AWG	-L = 10 μ" (0.25 μm) Gold on contact area	-00.25 = 0.25 meter -00.50 = 0.50 meter Standard lengths	-S = Socket	-BC = Blunt Cut (Color wire only, see chart) -01 = 2x6 SFSD (Pin 1 to Pin 1) (Black wire only)

-BC CABLE COLOR CODING

PIN	COLOR
1	BROWN
2	RED
3	ORANGE
4	YELLOW
5	GREEN
6	DARK BLUE
7	VIOLET
8	GRAY
9	WHITE
10	BLACK
11	GREEN/BLACK
12	TAN

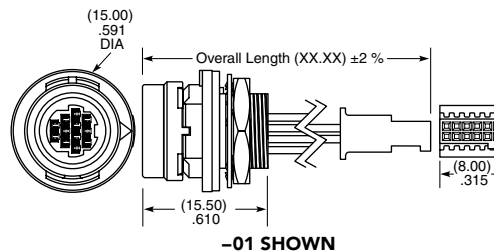

DUST CAPS

-S (socket) = DCA-MCR-8
-T (terminal) = DCA-MCP-8

Notes:

Samtec's MCR, MCP Series is dual sourced by Hirose Electric Co. LTD

Some lengths, styles and options are non-standard, non-returnable

IP68 SEALED USB & ETHERNET



SCRUS/SCRES SERIES

SCRUS
Mates with:
SCPU

SCRUS	SHELL SIZE	PLATING	WIRE LENGTH	END 1 OPTION	END 2 OPTION
	-17 (Standard USB only)	-G = 30 μm (0.76 μm) Gold on Contact, Nickel on Shell	-00.25 = (0.25 m) 9.84" Cable -00.50 = (0.50 m) 19.68" Cable Standard lengths (Assembled Length = Wire Length + (37.9 mm) 1.50")	-AMS = USB A Type, Sealed -BMS = USB B Type, Sealed -MBS = Mini USB B Type, Sealed	-AM = USB A Type, Not Sealed -BM = USB B Type, Not Sealed -MB = Mini USB B Type, Not Sealed -BC = Blunt Cut

SPECIFICATIONS

Insulator Material:

PBT

Contact Material:

Phosphor Bronze

Wire:

20 AWG (Power)
25 AWG (Signal)
28 AWG (Drain)

O-Ring:

Silicone

Operating Temp Range:

-20 °C to +75 °C

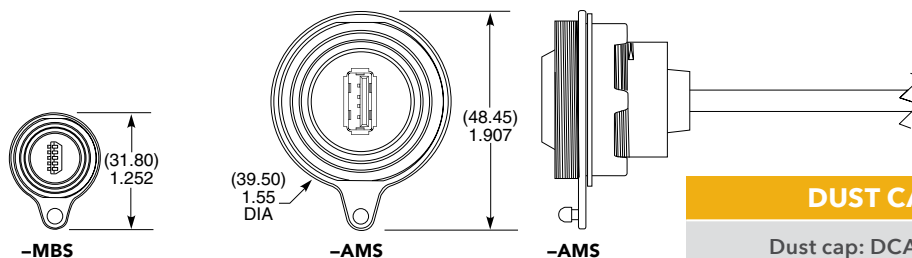

DUST CAP

Dust cap: DCA-17-03
(USB Flash Drive Cover)

SCRES
Mates with:
SCPE

SCRES	PLATING	WIRE LENGTH	END OPTION	C5E
	-G = 50 μm (1.27 μm) Gold on Contact, Nickel on Shell	-00.25 = (0.25 m) 9.84" Cable -00.50 = (0.50 m) 19.68" Cable Standard lengths	-D = Double Ended -BC = Blunt Cut	-C5E = Cat 5e rating

SPECIFICATIONS

Insulator Material:

PBT

Contact Material:

Phosphor Bronze

Shield Material:

Phosphor Bronze

Wire:

24 AWG

O-Ring:

Silicone

Overmold:

PA66

Current Rating:

3.8 A per pin
(1 pin powered)

Operating Temp Range:

-40 °C to +70 °C

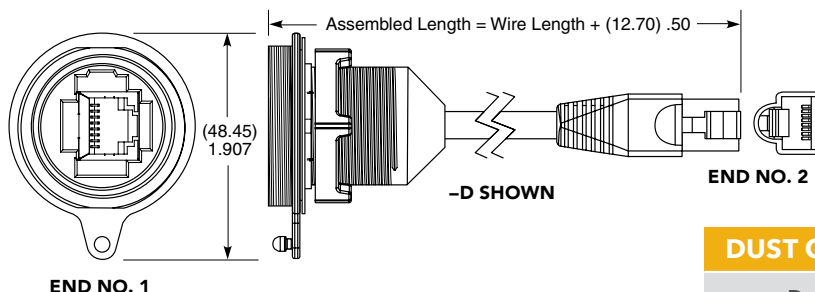

DUST CAP & PANEL PLUG

Dust cap: DCA-17-01
Panel Plug: SCPPA-17-01

Note:
Some lengths, styles and options are non-standard, non-returnable.

IP68 SEALED ETHERNET SOCKET

RPBE, RPCE SERIES



RPBE
Mates with:
RCE

RPBE

NO. OF PORTS

LEAD STYLE

PLATING

-01, -02

-01
= Right-angle

-E
= 50 μ" (1.27 μm) Gold on contact,
Flash Gold on tail

SPECIFICATIONS

Insulator Material:
Black Liquid Crystal Polymer
Contact:
Phosphor Bronze
Operating Temp Range:
-40 °C to +75 °C
Seal:
Rubber
Screw:
Stainless Steel
Nut:
Stainless Steel
Sealing Washer:
Rubber

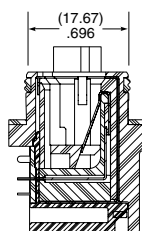
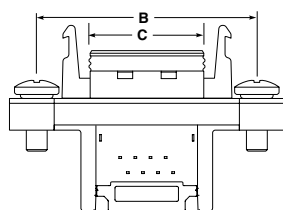
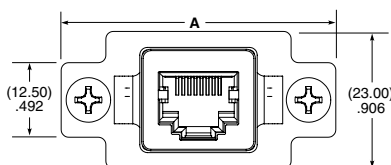

NO. OF PORTS	A	B	C
-01	(46.10) 1.815	(36.95) 1.455	(19.72) .776
-02	(67.10) 2.642	(57.95) 2.281	(40.72) 1.603

DUST CAPS

- 01 = DCA-RPBE-01-01-P (Push-On/No Latch)
- 01 = DCA-RPBE-01-01-L (Latching)
- 02 = DCA-RPBE-02-01-L (Latching)

RPCE
Mates with:
RCE

RPCE

01

PLATING

CABLE LENGTH

END OPTION

C5E

-E
= 50 μ" (1.27 μm)
Gold on contact,
Nickel on shell

-00.25
= (0.25 m) 9.84"

-D
= Double Ended

-00.50
= (0.50 m) 19.69"

Standard lengths

-BC
= Blunt Cut

SPECIFICATIONS

Insulator Material:
Glass Filled Thermoplastic
Contact:
Phosphor Bronze
Shield:
Phosphor Bronze
Operating Temp Range:
-40 °C to +75 °C
Overmold:
Rite Flex 640F
Seal:
Rubber
Screw:
Stainless Steel
Nut:
Stainless Steel
Sealing Washer:
Rubber
Wire:
24 AWG

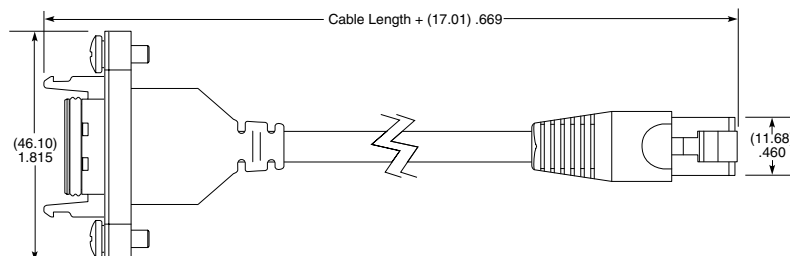
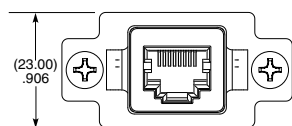

Note:
Some lengths, styles and options are non-standard, non-returnable

IP68 SEALED USB PANEL MOUNT

RPBU, RPCU SERIES



RPBU
Mates with:
RCU (Single Port only)

SPECIFICATIONS

Insulator Material:
Black Liquid Crystal Polymer
Contact:
Phosphor Bronze
Current Rating:
4.2 A per pin
(1 pin powered)
Operating Temp Range:
-20 °C to +80 °C
Seal: Silicone
Lead-Free Solderable:
Yes

RPBU	NO. OF PORTS	PLATING	TYPE	LEAD STYLE	OPTION
	-01 = Single Port	-S = 30 μ" (0.76 μm) Gold on contact, Matte tin on tail	-A = USB A Type -B = USB B Type	-VT = Vertical Through-hole -RA = Right-angle	-LC = Locking Clip (-VT only)

NO. OF PORTS	A	B	C
-01	(48.15) 1.896	(39.10) 1.539	(20.01) .788
-02	(69.80) 2.748	(60.75) 2.392	(42.00) 1.654

DUST CAPS			
DCA-RPBU-01-01-A			
DCA-RPBU-02-01-A			
DCA-RPBU-01-01-B			

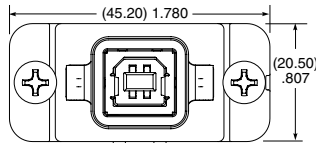

TYPE -B

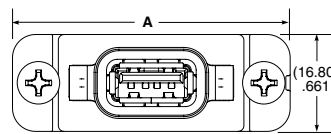

TYPE -A

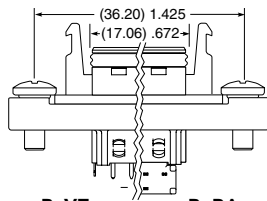

-B-VT -B-RA

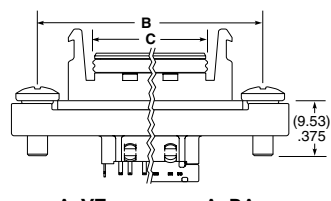

-A-VT -A-RA

RPCU
Mates with:
RCU

SPECIFICATIONS

Insulator Material:
Black Liquid Crystal Polymer
Contact Material:
Phosphor Bronze
Operating Temp Range:
-20 °C to +80 °C
Shield Material:
Phosphor Bronze
Wire:
20 AWG (Power)
25 AWG (Signal)
28 AWG (Drain)

RPCU	PLATING	CABLE LENGTH	END 1 OPTION	END 2 OPTION
	-G = 30 μ" (0.76 μm) Gold on contact, Nickel on shell	-00.25 = (0.25 m) 9.84" Cable -00.50 = (0.50 m) 19.68" Cable Standard lengths (Assembled Length = Cable Length + (42.8 mm) 1.69")	-AMS = USB A Type, Sealed -BMS = USB B Type, Sealed	AM = USB A Type, Not Sealed -BM = USB B Type, Not Sealed -BC = Blunt Cut

Note:
Some lengths, styles and options are non-standard, non-returnable

RUGGED FEATURES

OPTIONS FOR HIGH-RELIABILITY, HIGH-RETENTION AND HIGH-CYCLE LIFE

RUGGEDIZING OPTIONS



JACK SCREWS

Ideal for high normal force, zippering and other rugged applications

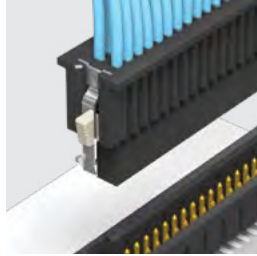

POSITIVE LATCHING

Manually activated latches increase unmating force by up to 200%

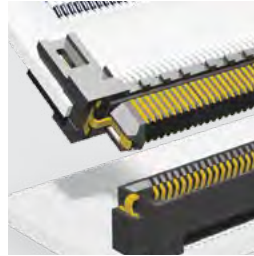

FRICTION LOCKS

Metal or plastic friction locks increase retention/withdrawal force



RETENTION PINS

Increase unmating force by up to 50%



BOARD LOCKS

Boards are mechanically locked together



WELD TABS

Significantly increase shear resistance of connector to PCB

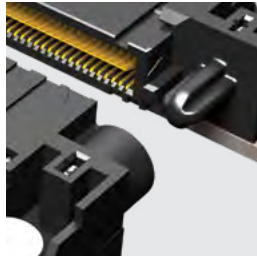

GUIDE POSTS

Easy and secure mating



SHIELDING

360° shielding reduces EMI



SCREW DOWNS

Secure mechanical attachment to the board

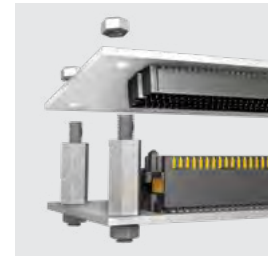

BOARD STANDOFFS

Precision machined standoffs for 5 mm to 25 mm board spacing

CONTACT SYSTEMS



TIGER EYE™

High-reliability
High Mating Cycles
Multi-finger Contact



TIGER CLAW™

Dual Wipe Contact
Pass-through Applications
Ultra-low Profile



BLADE & BEAM

Mating/Alignment
"Friendly"
Cost-effective



TIGER BEAM™

Best Cost
Reliable Performance
Post & Beam Contact



EDGE RATE®

Designed for
Signal Integrity
Superior Impedance Control
Reduced Broadside Coupling

FLEXIBLE STACKING

VARIETY OF PITCHES, CONTACT SYSTEMS & ORIENTATIONS • HIGHLY CUSTOMIZABLE

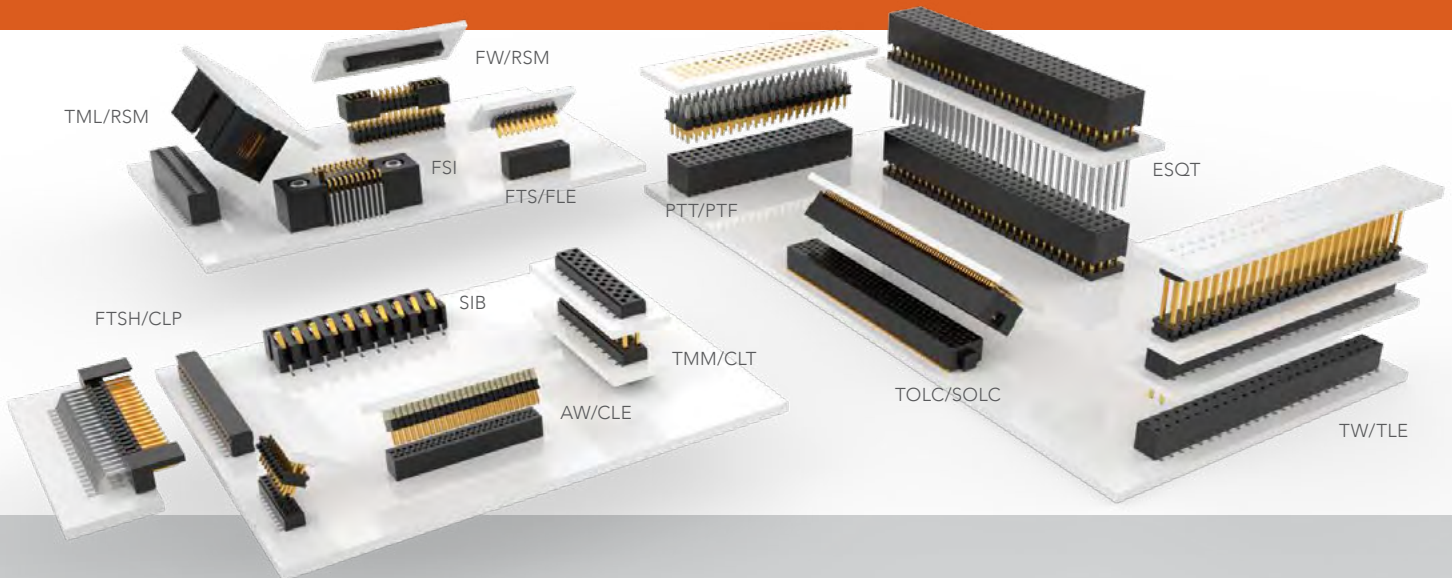

234-235

ONE-PIECE INTERFACES

1.00 mm (.0394") Pitch (FSI)	234
1.00" (2.54 mm) (SIB, SIR1)	235

236-241

MICRO BLADE & BEAM

0.50 mm (.0197") Pitch Low-Profile Systems (LTH, LSH)	236
Floating Contact Systems (FT5, FS5)	237
Basic Blade & Beam Systems (BXH, BXS, BXE)	238-241

242-258

MICRO PIN & SOCKET

0.80 mm (.0315") Pitch Headers & Sockets (FTE, CLE, AW)	242-243
1.00 mm (.0394") Pitch Headers, Stackers & Sockets (FTMH, FTM, MW, CLM, MLE)	244-246
Quad Row Headers & Sockets (SOLC, TOLC)	247
.050" (1.27 mm) Pitch Headers, Stackers & Sockets (FTSH, FTS, FW, CLP, FLE)	248-253
.050" (1.27 mm) x 100" (2.54 mm) Pitch Headers, Stackers & Sockets (TMS, HTMS, TML, ZML, DWM, FTR, RSM, SLM, SMS)	254-258

259-292

BOARD-TO-BOARD

2.00 mm (.0787") Pitch Headers & Stackers (TMM, MMT, MTMM, TMMH, LTMM, ZLTMM, TMMS, TSH, TW)	259-266
2.00 mm (.0787") Pitch Press-Fit Headers & Sockets (PTT, PTF, PTHF, ESQT-368)	267-268
2.00 mm (.0787") Pitch Sockets (SQW, SQT, MMS, TLE, CLT)	269-271
2.00 mm (.0787") Pitch Self Mating Hermaphroditic Strips (LS2)	272
.100" (2.54) Pitch Square Post Headers & Stackers (PHT, PHF, TSW, HTSW, TSM, MTSW, HMTSW, TLW, MTLW, HW, DW, EW, ZW, TSS, HTSS, ZSS)	273-283
.100" (2.54 mm) Pitch Square Post Sockets (SSW, SSQ, SSM, ESW, ESQ, HLE, BCS, BSW, SLW, CES)	284-291
Shunts & Jumpers (SNT, MNT, 2SN, SNM, JL)	292

FLEXIBLE STACKING

With the largest variety of board-to-board interconnects, Samtec makes it easy to find board stackers for any application. Header and socket systems are available in a variety of pitch, density, stack height, orientation and many more standard or custom options.

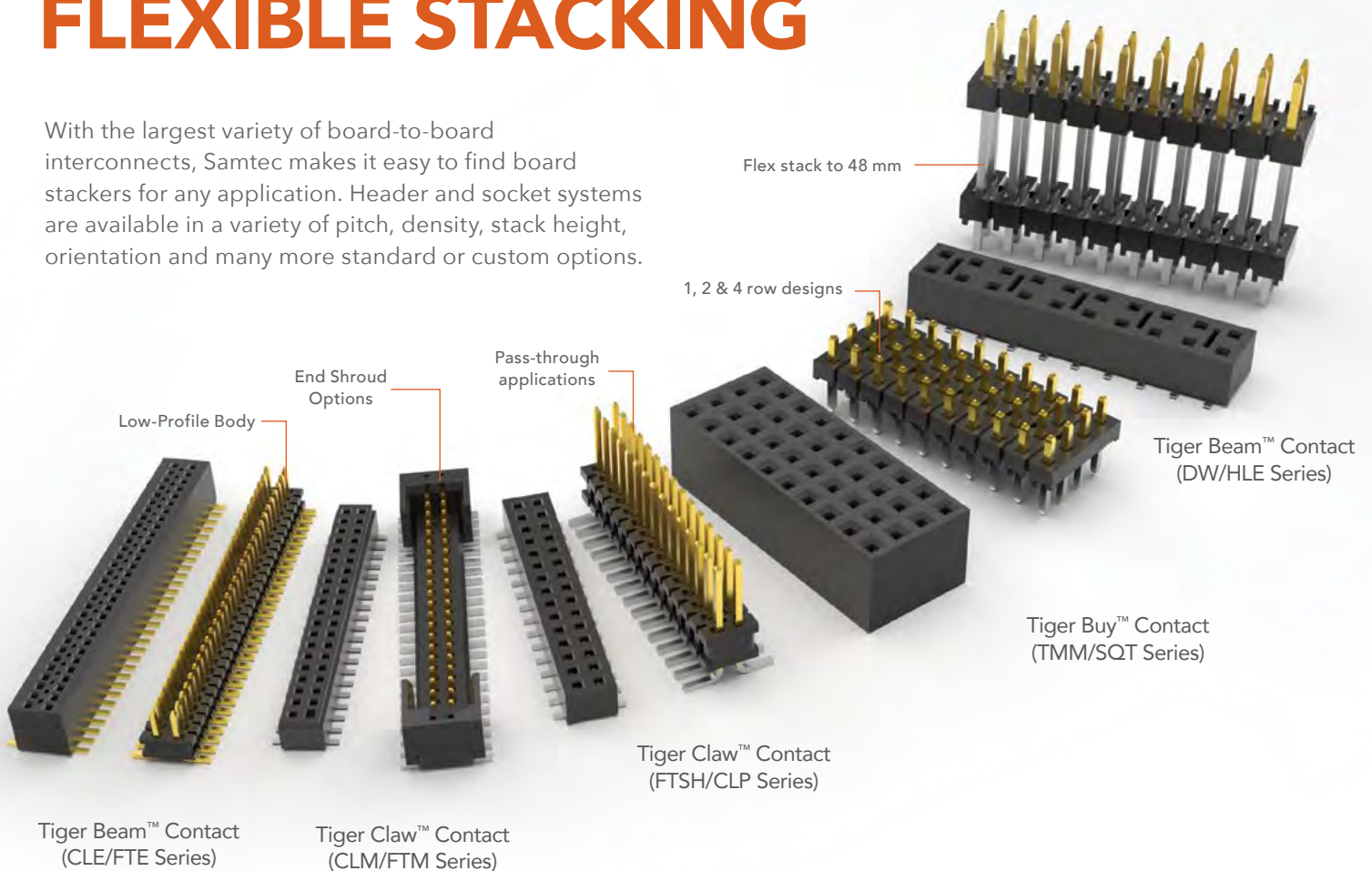

INCREDIBLE FLEXIBILITY

- Post height: Adjustable in .005" (0.13 mm) increments
- Body positions: Adjustable in .005" (0.13 mm) increments
- Board stacking distance: 1.65 mm (.065") – 48.51 mm (1.910")
- Number of pins: 2-300
- Number of rows: 1-6

CUSTOMIZABLE

- Mix-and-match headers and sockets to find the right solution
- Quick and easy custom parts are available.
Contact asp@samtec.com

VARIETY OF PITCHES

- 0.80 mm (.0315")
- 1.00 mm (.0394")
- .050" (1.27 mm)
- .050" x .050" (1.27 x 1.27 mm)
- .050" x .100" (1.27 x 2.54 mm)
- 2.00 mm (.0787")
- .100" (2.54 mm)
- .156" (3.96 mm)
- .200" (5.08 mm)

BUILD IT YOURSELF

Check out Solutionator® to quickly build a mated set for your specific application. Visit samtec.com/solutionator



VARIETY OF CONTACTS

TIGER EYE™ CONTACT

- High-reliability
- High mating cycles
- Multi-finger contact



TIGER CLAW™ CONTACT

- Pass-through
- Ultra-low profile
- Dual wipe contact

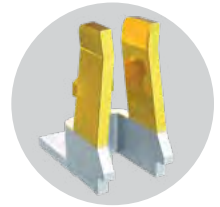

TIGER BUY™ CONTACT

- High-retention
- Cost-effective
- Tuning fork contact

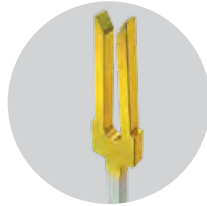

TIGER BEAM™ CONTACT

- Best cost
- Reliable performance
- Post & beam contact



VARIETY OF ORIENTATIONS/APPLICATIONS

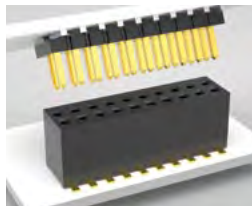

Standard

- Choice of contact system
- Single, double and triple row designs
- Largest variety

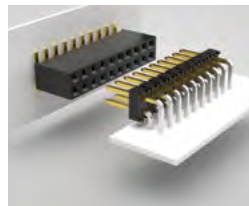

Right-Angle

- Design flexibility
- Tiger Claw™ & Tiger Buy™ contacts
- Through-hole, surface mount



Low Profile

- Down to 1.65 mm (.065") stack height
- Tiger Claw™ contacts
- Space saving

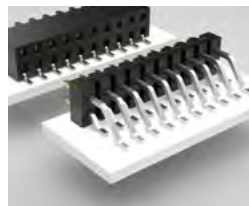

Coplanar

- 1-4 row designs
- Surface mount, through-hole or mixed technology
- Tiger Claw™ & Tiger Beam™ contacts



Elevated

- Up to 48.51 mm (1.910") stack height
- Design flexibility
- Clearance, air flow

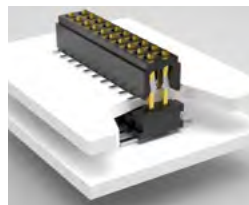

Bottom Entry

- Tiger Claw™ contacts
- Access to components when mated
- Space savings



Pass-Through

- Connect three or more boards
- Tiger Claw™ & Tiger Beam™ contact systems
- Surface mount or offset through-hole

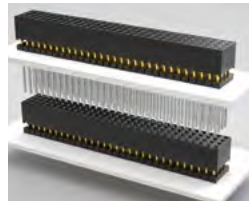

Self-Nesting

- Tiger Buy™ contacts
- Press-fit or through-hole tails
- PC/104-Plus™ embedded applications

BOARD STACKING REFERENCE

Focused/most popular series in charts. For all flexible stacking solutions, visit samtec.com/connectors

ONE-PIECE, 0.80 mm (.0315") & 1.00 mm (.0394") PITCH

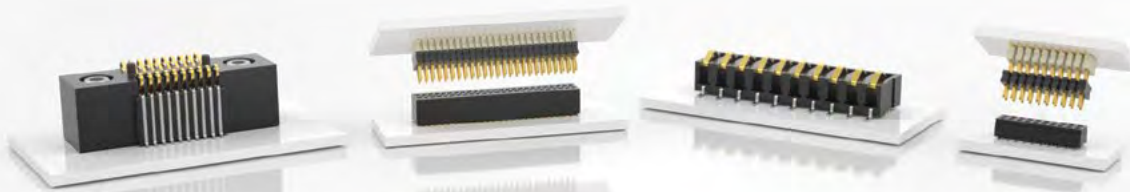

SERIES	FSI	SEI	SIB	CLE	FTE	CLM	FTMH/FTM	MLE	MW	
PITCH	1.00 mm (.0394")		.100" (2.54 mm)	0.80 mm (.0315")		1.00 mm (.0394")				
ORIENTATION	V				V & RA	V	V & RA	V		
BOARD STACKING (MM)	MIN	3	1.65	3.8	5	5	3.48		4.57	4.62
	MAX	10			9.14		8.43	5.11	9.27	
CONTACT SYSTEM					Tiger Beam™		Tiger Claw™		Tiger Beam™	
MATES	One-Piece				FTE, AW	CLE	FTM, FTMH, MW	CLM, MLE	FTM, FTMH, MW	CLM, MLE
PAGE	234	See Website	235	242	242	246	244	246	245	

.050" (1.27 mm) PITCH HEADERS & SOCKETS

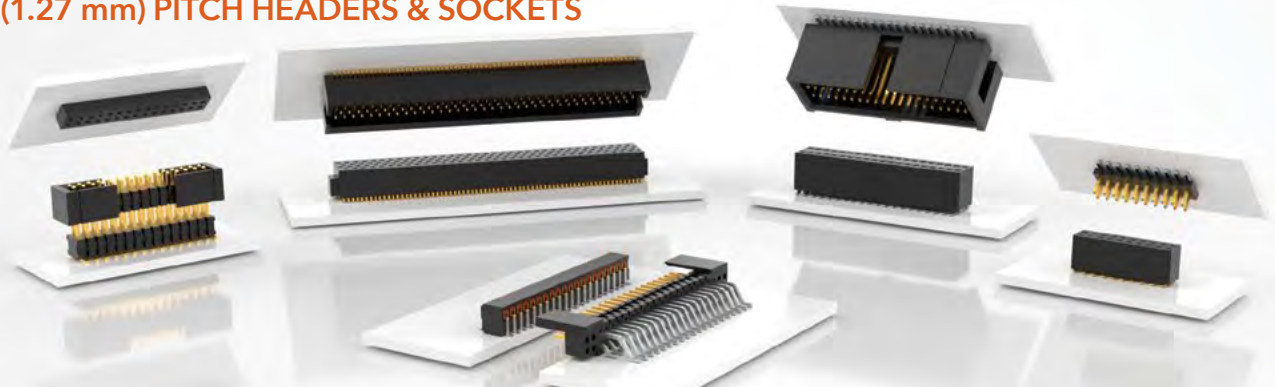

SERIES	CLP	FLE	FTS	FTSH	FW	SOLC	TOLC	DWM/HDWM	FTR	RSM	SLM
PITCH	.050" x .050" (1.27 mm x 1.27 mm)							.050" x .100" (1.27 mm x 2.54 mm)			
ORIENTATION	V & RA	V		V & RA	V						
BOARD STACKING (MM)	MIN	3.53	5.82	3.53	5.18	7.72	6.35	9.65	9.78		7.11
	MAX	17.75	19.15	5.82	7.49	19.15	12.00	22.99	14.73	19.69	19.43
CONTACT SYSTEM	Tiger Claw™	Tiger Beam™				Tiger Buy™					Tiger Buy™
MATES	FTSH, FTS, FW			CLP, FLE		TOLC	SOLC	SMS, SLM, RSM		FTR, HTMS, HDWM, TML, ZML, TMS	HTMS, TMS, MTMS, DWM, HDWM, FTR, HMTMS
PAGE	252	253	250	248-249	251	247	247	256	257	257	258

2.00 mm (.0787") PITCH HEADERS & SOCKETS

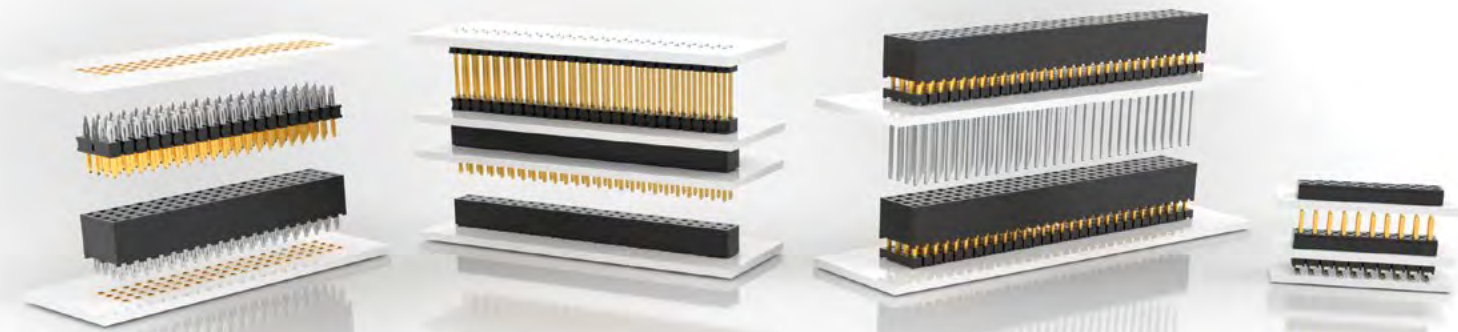

SERIES	MMT	TMM/ MTMM	TMMH	TW	ZLTMM	CLT	ESQT/ -368	MMS	SMM	SQT	SQW	TLE
ORIENTATION	RA	V & RA		V				V & RA	V	V & RA	V	
TERMINATION	SMT & MT	T/H & SMT			T/H	T/H & SMT	T/H	T/H & SMT	SMT	T/H	T/H & SMT	SMT
BOARD STACKING (MM)	MIN	2	3.63	4.14	7.49	7.62	3.63	9.37	5.94	6.07	7.85	6.99
	MAX	4	18.87	22.07	43.31	13.34	4.98	43.31	19.81	17.78	29.59	17.53
CONTACT SYSTEM						Tiger Claw™	Tiger Buy™	Tiger Claw™	Tiger Eye™	Tiger Buy™		Tiger Beam™
MATES	CLT, SQT, SQW, ESQT, TLE, SMM, MMS				SQT, SQW, ESQT, SMM	TMM, TMMH, MTMM, MMT, TW, TSH	TMMH, TMM, MTMM, MMT, TW, ZLTMM, ESQT, PTT, TSH, TMMS, PTHF	TMMH, TMM, MTMM, MMT, TW, ZLTMM, TSH	TMM, TMMH, MTMM, MMT, LTMM, TW, PTT, ZLTMM	TMMH, TMM, MTMM, MMT, TW, TSH, LTMM, PTT	TMMH, TMM, MTMM, MMT, TW, TSH, LTMM, PTT	TMMH, TMM, MTMM, MMT, TW, LTMM, ZLTMM, TSH
PAGE	261	259-261	262-263	266	264	271	268	270	194	269	269	271

.100" (2.54 mm) PITCH HEADERS & SOCKETS



SERIES	DW, EW, ZW	HW	MTSW/ HMTSW	TLW/ MTLW	TSM	TSW/ HTSW	BCS	ESW, ESQ	HLE	SSM	SSQ	SSW
ORIENTATION	V		V & RA				V & RA	V		V & RA		
TERMINATION	T/H	T/H & SMT	T/H		SMT & MT	T/H		T/H & SMT	SMT	T/H	T/H & SMT	
BOARD STACKING (MM)	MIN	13.59	10.03	7.24	6.1	7.47	7.87	9.02	13.59	7.47	11.18	10.03
	MAX	48.51	30.73	46.36	20.96	14.48	35.69	18.92	48.51	26.16	30.1	38.35
CONTACT SYSTEM							Tiger Claw™	Tiger Buy™	Tiger Beam™	Tiger Claw™	Tiger Buy™	
MATES	SSW, SSQ, ESW, ESQ, CES, SLW, BSW, BCS, SSM, HLE, PHF		SSW, SSQ, ESW, ESQ, BCS, BSW, CES, SLW, HLE, SSM	BSW, CES, SLW, HLE	SSW, SSQ, SSM, BSW, ESW, ESQ, BCS, BSW, CES, SLW, HLE	SSW, SSQ, SSM, ESW, ESQ, BCS, BSW, CES, SLW	TSW, MTSW, HTSW, HMTSW, TSS, ZSS, DW, EV, ZW, HW, TSM, MTLW, PHT	TSW, MTSW, EW, MTLW, TSS, ZSS, TSM, DW, ZW, HW, TSSH, HTSS	TSW, MTSW, DW, EV, ZW, TLW, TSM, MTLW, HW	TSW, MTSW, TST, TSS, ZST, ZSS, DW, EV, ZW, TSM, HMTSW, HTSW, TSSH, BST, HTSS, TLW, MTLW	TSW, MTSW, MTLW, EV, ZW, TSS, TSM, TSSH, HTSS	TSW, MTSW, HTSW, HMTSW, MTLW, EV, ZW, TSS, HTSS, ZSS, TSM, TSSH, DW, HW
PAGE	282	281	278-279	280	276-277	274-275	289	287	288	286	284-285	

LOW-PROFILE AND ELEVATED ONE-PIECE

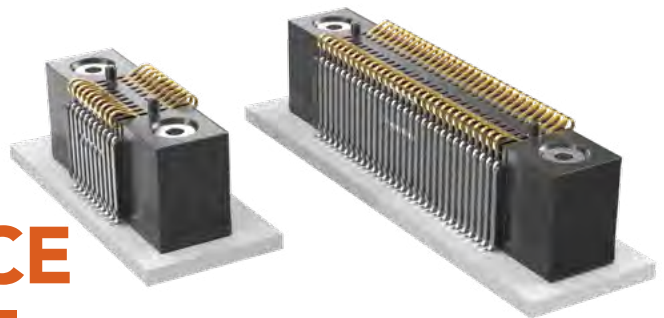

(1.00 mm) .0394" PITCH • FSI SERIES

SPECIFICATIONS

Insulator Material:
Liquid Crystal Polymer
Contact Material:
BeCu
Current Rating:
2.8 A per pin
(2 pins powered)
Operating Temp Range:
-55 °C to +125 °C
Plating:
Au over 50 μm (1.27 μm) Ni

PROCESSING

Lead-Free Solderable:
Yes
SMT Lead Coplanarity:
(0.10 mm) .004" max (05-30)
(0.15 mm) .006" max (50)*
*(.004" stencil solution may be available; contact IPG@samtec.com)
Compression Board:
Gold Pads required

OTHER SOLUTIONS

Low Profile

See www.samtec.com?SEI

.050" (1.27 mm) Pitch

See www.samtec.com?SIBF

ALSO AVAILABLE

MOQ Required

No alignment pin
Top side alignment pin
Bottom side alignment pin
Other platings

Notes:
Applications requiring 40-50 positions without threaded inserts, please contact Samtec Interconnect Processing Group.

Some lengths, styles and options are non-standard, non-returnable.

FSI	1	PINS PER ROW	BODY HEIGHT	PLATING OPTION	ROW OPTION	INSERT OPTION	ALIGNMENT OPTION	OTHER OPTION
-----	---	--------------	-------------	----------------	------------	---------------	------------------	--------------

10, 20, 30, 50
(Insert/Screw Option)

05, 10, 20, 30, 50
(Short Version)

-03
= 3 mm

-06
= 6 mm

-10
= 10 mm

-G
= 10 μm
(0.25 μm)
Gold
(-03 only)

-L
= 10 μm
(0.25 μm)
Gold on contact,
Matte Tin on tail
(Not available with
-03 body height)

-S
= Single Row
(Available with 5, 10 & 20 pins with -AD alignment pin)

-D
= Double Row

Leave blank for Short Version
(No screw down inserts or holes)

-E
= #2-56 x 1/16" screw thread

-M
= 2.00 mm x 0.40 mm screw thread

Leave blank for no Alignment Pin

-AD
= Alignment Pin Top & Bottom

-WT
= Weld Tab
(Available with -S row option & -06 & -10 body height only)

-K
= Polyimide Film Pick & Place Pad
(50 position with threaded insert option only)

-P
= Plastic Pick & Place Pad
(5.08 mm) .200" x (12.45 mm) .490"
(50 not available with -E)
(Not available with -S row option or -03 body height)

-TR
= Tape & Reel

-FR
= Full Reel Tape & Reel
(must order max. quantity per reel; contact Samtec for quantity breaks)

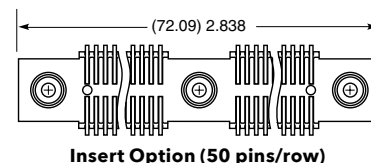
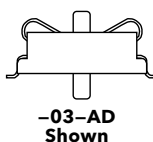
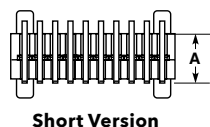
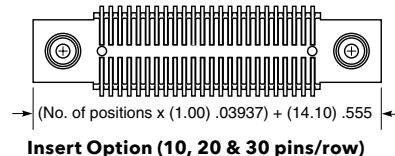
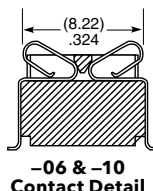
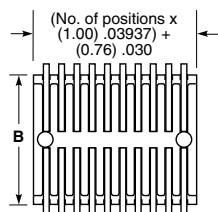

Double Row Version -03, -06, -10

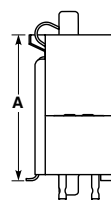
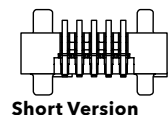
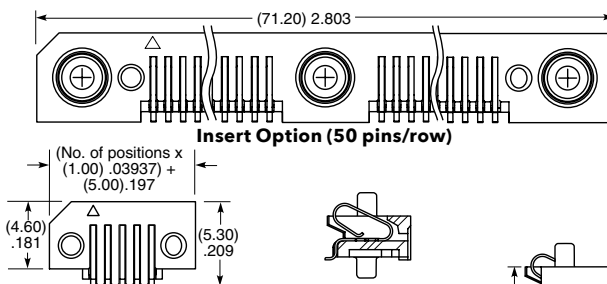

Single Row Version -03, -06, -10

BODY HEIGHT	A	B
-03	(3.00) .118	(8.76) .345
-06	(6.00) .236	(9.02) .355
-10	(10.00) .394	(9.02) .355

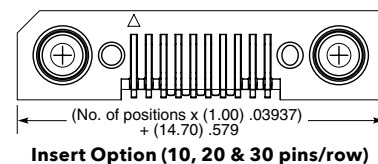

ONE-PIECE INTERFACES



(2.54 mm) .100" PITCH • SIB/SIR1 SERIES

SPECIFICATIONS

Insulator Material:
Black Liquid Crystal Polymer
Contact Material:
Phosphor Bronze
Plating:
Au or Sn over
50 μ" (1.27 μm) Ni
Current Rating:
2.6 A per pin
(1 pin powered)
Operating Temp Range:
-55 °C to +125 °C

SIB	-	1	NO. OF POSITIONS	-	02	PLATING OPTION	-	S	-	OPTION
			02 thru 30 (Per Row)			-F = Gold flash on contact, Matte Tin on tail				-LC = Locking Clip (Manual placement required)

PROCESSING

Lead-Free Solderable:
Yes
SMT Lead Coplanarity:
(0.10 mm) .004" max (02-19)
(0.15 mm) .005" max (20-30)*
*(.004" stencil solution may be available; contact IPG@samtec.com)

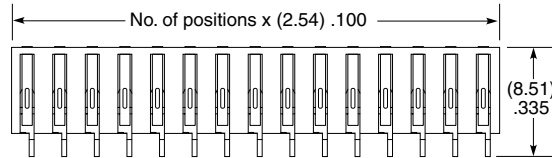

Notes:
The SIB Series is intended for vertical mating only.

Some lengths, styles and options are non-standard, non-returnable.

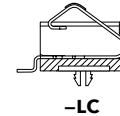
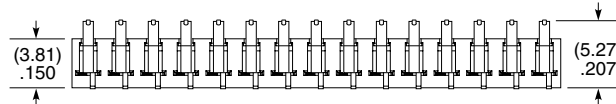

SPECIFICATIONS

Insulator Material:
Black LCP
Contact Material:
Phosphor Bronze
Weld Tab:
Phosphor Bronze
Plating:
Au or Sn over
50 μ" (1.27 μm) Ni
Current Rating:
2.8 A per pin
(1 pin powered)

SIR1	-	NO. OF POSITIONS	-	PLATING OPTION	-	S	-	OPTION
		-03, -05, -10, -15 (Per Row)		-L = 10 μ" (0.25 μm) Gold on contact, Matte Tin on tail -S = 30 μ" (0.76 μm) Gold on contact, Matte Tin on tail				-A = Alignment Pin -K = (4.00 mm) .157" DIA Polyimide Film Pick & Place Pad -TR = Tape & Reel -FR = Full Reel Tape & Reel (must order max. quantity per reel; contact Samtec for quantity breaks)

PROCESSING

Lead-Free Solderable:
Yes
SMT Lead Coplanarity:
(0.10 mm) .004" max

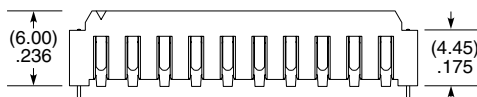
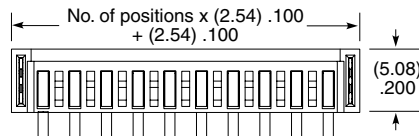

Note:
Some lengths, styles and options are non-standard, non-returnable.

samtec.com?SIB or samtec.com?SIR1

LOW-PROFILE BLADE AND BEAM

(0.50 mm) .0197" PITCH • LTH/LSH SERIES

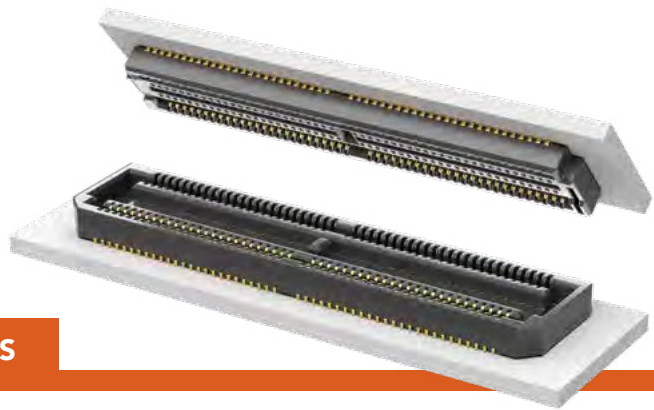

LTH
Mates:
LSH

LSH
Mates:
LTH

LTH	-	NO. OF POSITIONS PER ROW	-	01	-	PLATING OPTION	-	D	-	A	-	OTHER OPTION
-----	---	--------------------------	---	----	---	----------------	---	---	---	---	---	--------------

-010, -020,
-030, -040, -050

-G
= 10 μm
(0.25 μm)
Gold

-K
= (5.50 mm)
.217" DIA
Polyimide
film Pick &
Place Pad

-TR
= Tape & Reel

-FR
= Full Reel
Tape & Reel
(must order max.
quantity per reel;
contact Samtec for
quantity breaks)

SPECIFICATIONS

Insulator Material:

Liquid Crystal
Polymer

Terminal Material:

Phosphor Bronze

Contact Material:

BeCu

Plating:

Au over 50 μm (1.27 μm) Ni

Current Rating:

2.6 A per pin
(2 pins powered)

Operating Temp Range:

-55 °C to +125 °C

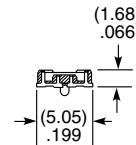
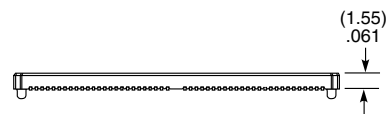
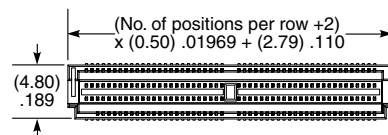

PROCESSING

Lead-Free Solderable:

Yes

SMT Lead Coplanarity:

(0.10 mm) .004" max

Board Stacking:

For applications requiring more than two connectors per board, contact ipg@samtec.com

LSH	-	NO. OF POSITIONS PER ROW	-	01	-	PLATING OPTION	-	D	-	A	-	OTHER OPTION
-----	---	--------------------------	---	----	---	----------------	---	---	---	---	---	--------------

-010, -020,
-030, -040, -050

-G
= 10 μm
(0.25 μm)
Gold

-K
= (7.50 mm)
.295" DIA
Polyimide
film Pick &
Place Pad

-TR
= Tape & Reel

-FR
= Full Reel
Tape & Reel
(must order max.
quantity per reel;
contact Samtec for
quantity breaks)

MATED HEIGHT

LEAD STYLE	MATED HEIGHT*
-01	(2.31 mm) .091"

*Processing conditions will affect mated height.

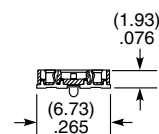
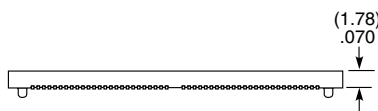
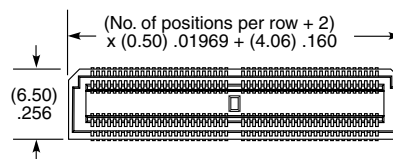

Note:

Some lengths, styles and options are non-standard, non-returnable.

HIGH-SPEED FLOATING CONTACT SYSTEM



(0.50 mm) .0197" PITCH • FT5/FS5 SERIES

FT5
Mates:
FS5

FS5
Mates:
FT5

SPECIFICATIONS

Insulator Material:
Black Liquid Crystal Polymer
Contact Material:
Phosphor Bronze (FT5)
BeCu (FS5)
Weld Tab:
Phosphor Bronze
Plating:
Au or Sn over
50 μ" (1.27 μm) Ni
Current Rating:
1.8 A per pin
(2 pins powered)
Operating Temp Range:
-55 °C to +125 °C
Lead-Free Solderable:
Yes

FT5	NO. OF POSITIONS	LEAD STYLE	PLATING OPTION	ROW OPTION	TH	OPTION
-----	------------------	------------	----------------	------------	----	--------

-15, -30
(Per Row)

-01.0
= 1 mm
Body
Height

-L
= 10 μ"
(0.25 μm)
Gold on
contact,
Matte Tin
on tail

-DV
= Vertical

Leave blank
for -RA

Required
callouts

-03.0
= 3 mm
Body
Height

-RA
= Right-
angle

-TH
= Through-hole
weld tab

-P
= Pick &
Place Pad
(-DV only)

-K
= (5.00 mm)
.197" DIA
Polyimide
Film Pick &
Place Pad
(-RA only)

-TR
= Tape &
Reel

-FR
= Full Reel
Tape & Reel
(must order
max. quantity
per reel;
contact
Samtec for
quantity
breaks)

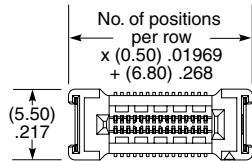

LEAD STYLE	A
-01.0	(3.72) .146
-03.0	(5.72) .225

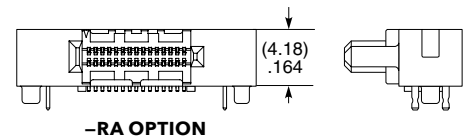
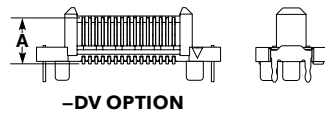
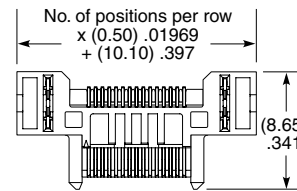

MATED HEIGHT *

FS5 LEAD STYLE	FT5 LEAD STYLE	
	-01.0	-03.0
-02.0	(5.00 mm) .197"	(7.00 mm) .276"

*Processing conditions will affect mated height.

FS5	NO. OF POSITIONS	LEAD STYLE	PLATING OPTION	DV	TH	K	XR
-----	------------------	------------	----------------	----	----	---	----

-15, -30
(Per Row)

-04.0
= 4 mm
Body
Height

-L
= 10 μ"
(0.25 μm)
Gold on
contact,
Matte Tin
on tail

-TH
= Through-hole
weld tab

-K
= (8.25 mm)
.325" DIA
Polyimide
Film Pick &
Place Pad

-TR
= Tape & Reel

-FR
= Full Reel
Tape & Reel
(must order
max. quantity
per reel;
contact
Samtec for
quantity
breaks)

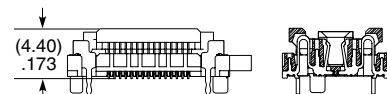
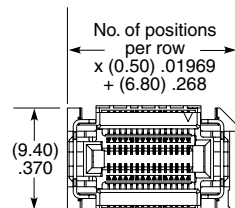

ALSO AVAILABLE
MOQ Required

Other lead counts
Surface mount weld tab

Notes:

Floating contact system provides 0.50 mm float in X and Y directions.

Some lengths, styles and options are non-standard, non-returnable.

BASIC BLADE & BEAM HEADER

(0.50 mm) .0197" PITCH • BTH SERIES

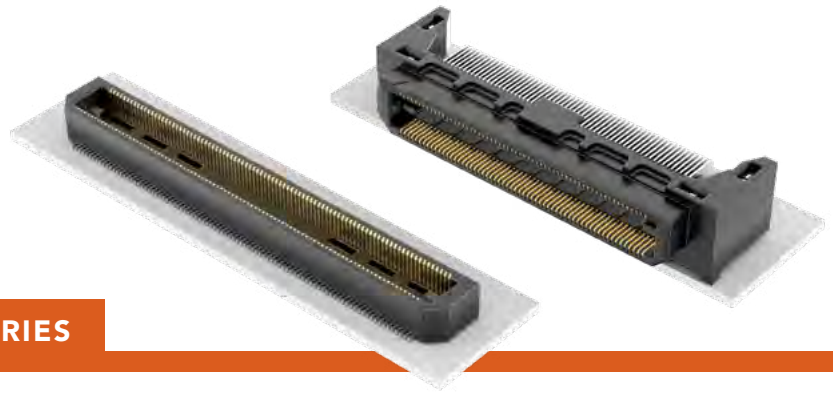

BTH

Mates:
BSH

SPECIFICATIONS

Insulator Material:

Black LCP

Contact Material:

Phosphor Bronze

Plating:

Au or Sn over
50 μ" (1.27 μm) Ni

Current Rating:

2.0 A per pin
(2 pins powered)

Operating Temp Range:

-55 °C to +125 °C

Voltage Rating:

175 VAC

Max Cycles:

100

PROCESSING

Lead-Free Solderable:

Yes

SMT Lead Coplanarity:

Vertical=

(0.10 mm) .004" max (030-090),

(0.15 mm) .006" max (120-150)*

Right-angle=

(0.15 mm) .006" max (030-090)*

*(.004" stencil solution

may be available; contact

IPG@samtec.com)

Board Stacking:

For applications requiring more

than two connectors per board

or 90 positions or higher,

contact ipg@samtec.com

ALSO AVAILABLE

MOQ Required

30 μ" (0.76 μm) Gold

Edge Mount Capability

8 mm, 11 mm, 16 mm,

19 mm and 22 mm Stack

Height (Caution: Some

automatic placement/

inspection machines may

have component height

restrictions. Please consult

machinery specifications.)

(11 mm, 16 mm, 19 mm

and 22 mm not available

with 50 positions)



Note:

Some lengths, styles and options are non-standard, non-returnable.

BTH	NO. OF POSITIONS PER ROW	01	PLATING OPTION	D	A	OTHER OPTION
-----	--------------------------	----	----------------	---	---	--------------

-030, -050, -060,
-090, -120, -150

-F
= Gold Flash
on contact,
Matte Tin on tail

-L
= 10 μ" (0.25 μm)
Gold on contact,
Matte Tin on tail

-C*
= Electro-Polished Selective
50 μ" (1.27 μm) min
Au over 150 μ" (3.81 μm)
Ni on Signal Pins in contact
area, Matte Tin over
50 μ" (1.27 μm) min
Ni on all solder tails
(*C Plating passes
10 year MFG testing)

-K
= (7.00 mm) .276"
DIA Polyimide
Film Pick
& Place Pad

-TR
= Tape & Reel
(120 positions
maximum)

-FR
= Full Reel
Tape & Reel
(must order
maximum
quantity
per reel;
contact
Samtec for
quantity breaks)
(120 positions
maximum)

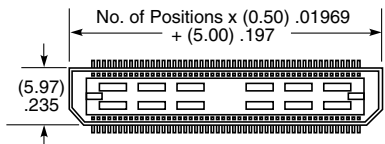

MATED HEIGHT

LEAD STYLE	MATED HEIGHT*
-01	(5.00 mm) .1971"

*Processing conditions will affect mated height.

BTH	NO. OF POSITIONS PER ROW	01	PLATING OPTION	D	RA	WT	OTHER OPTION
-----	--------------------------	----	----------------	---	----	----	--------------

-030, -060, -090

-F
= Gold Flash on
contact, Matte
Tin on tail

-L
= 10 μ" (0.25 μm)
Gold on contact,
Matte Tin on tail

-K
= (7.00 mm)
.276" DIA
Polyimide
Film Pick &
Place Pad

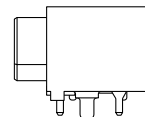
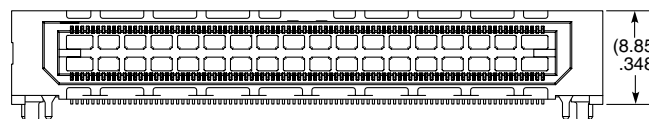
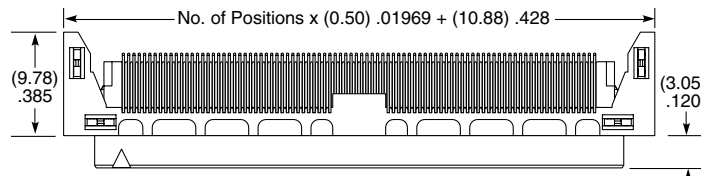

BASIC BLADE & BEAM SOCKET

(0.50 mm) .0197" PITCH • BSH SERIES



BSH
Mates:
BTH

SPECIFICATIONS

Insulator Material:
Black LCP
Contact Material:
Phosphor Bronze
Plating:
Au or Sn over
50 μ" (1.27 μm) Ni
Current Rating:
2 A per pin
(2 pins powered)
Operating Temp Range:
-55 °C to +125 °C
Voltage Rating:
175 VAC
Max Cycles:
100

PROCESSING

Lead-Free Solderable:
Yes
SMT Lead Coplanarity:
(0.10 mm) .004" max (030-090)
(0.15 mm) .006" max (120-150)*
*(.004" stencil solution
may be available; contact
IPG@samtec.com)
Board Stacking:
For applications requiring more
than two connectors per board
or 90 positions or higher,
contact ipg@samtec.com

ALSO AVAILABLE

MOQ Required

30 μ" (0.76 μm) Gold
Edge Mount Capability
8 mm, 11 mm, 16 mm, 19 mm
and 22 mm Stack Height
(Caution: Some automatic
placement/inspection
machines may have
component height
restrictions. Please consult
machinery specifications.)
(11 mm, 16 mm, 19 mm
and 22 mm not available
with 50 positions)



Note:
Some lengths, styles and
options are non-standard,
non-returnable.

BSH	-	NO. OF POSITIONS PER ROW	-	01	-	PLATING OPTION	-	D	-	A	-	OTHER OPTION
------------	---	---------------------------------	---	-----------	---	-----------------------	---	----------	---	----------	---	---------------------

**-030, -050, -060,
-090, -120, -150**

-F
= Gold Flash
on contact,
Matte Tin on tail

-L
= 10 μ" (0.25 μm)
Gold on contact,
Matte Tin on tail

-C*
= Electro-Polished
Selective
50 μ" (1.27 μm) min
Au over 150 μ" (3.81 μm)
Ni on Signal Pins in
contact area,
Matte Tin over
50 μ" (1.27 μm) min
Ni on all solder tails
(*-C Plating passes
10 year MFG testing)

-TR
= Tape & Reel
(120 positions
maximum)

-FR
= Full Reel
Tape & Reel
(must order
maximum
quantity
per reel;
contact
Samtec for
quantity breaks
(120 positions
maximum)

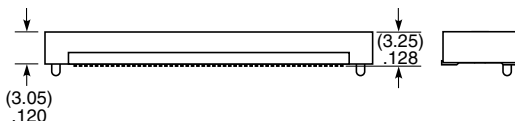
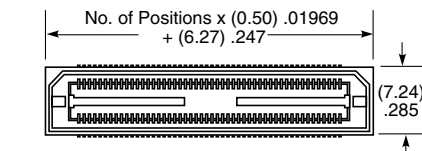

MATED HEIGHT

LEAD STYLE	MATED HEIGHT*
-01	(5.00 mm) .1971"

*Processing conditions
will affect mated height.

BSH	-	NO. OF POSITIONS PER ROW	-	01	-	PLATING OPTION	-	D	-	RA	-	WT	-	OTHER OPTION
------------	---	---------------------------------	---	-----------	---	-----------------------	---	----------	---	-----------	---	-----------	---	---------------------

-030, -060, -090

-F
= Gold Flash
on contact,
Matte Tin on tail

-L
= 10 μ" (0.25 μm)
Gold on contact,
Matte Tin on tail

-GP
= Guide
Post

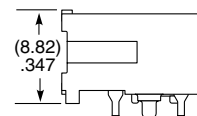
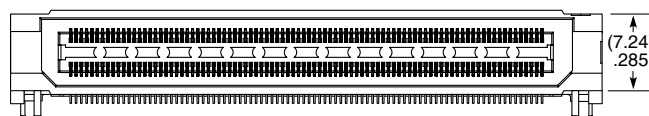
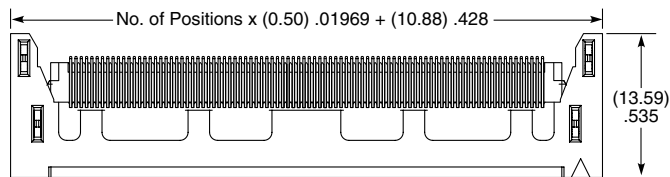

BASIC BLADE & BEAM HEADER & SOCKET

(0.635 mm) .025" PITCH • BTS/BSS SERIES

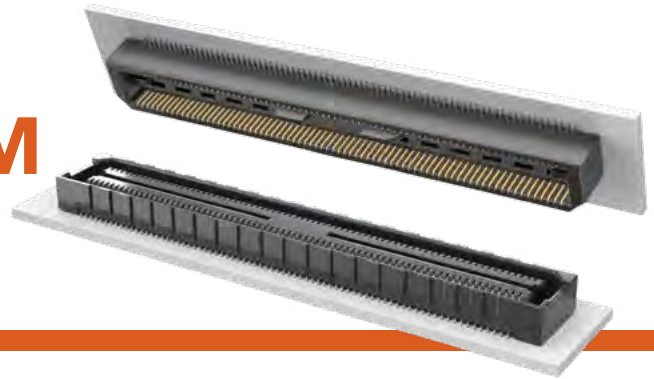

BTS
Mates:
BSS

BSS
Mates:
BTS

BTS	NO. OF POSITIONS PER ROW	01	PLATING OPTION	D	A	OTHER OPTION
------------	---------------------------------	-----------	-----------------------	----------	----------	---------------------

-025, -050,
-075, -100

-F
= Gold Flash on contact,
Matte Tin on tail

-L
= 10 μ" (0.25 μm)
Gold on contact,
Matte Tin on tail

-K
= (7.00 mm)
.275" DIA
Polyimide Film
Pick & Place Pad

-TR
= Tape & Reel
(-100 positions max.)

-FR
= Full Reel
Tape & Reel
(must order max.
quantity per reel;
contact Samtec for
quantity breaks)
(-100 positions max.)

SPECIFICATIONS

Insulator Material:
Liquid Crystal Polymer
Terminal Material:
Phosphor Bronze
Contact Material:
Phosphor Bronze
Plating:
Au or Sn over 50 μ" (1.27 μm) Ni
Current Rating:
1.8 A per pin
(2 pins powered)
Operating Temp Range:
-55 °C to +125 °C

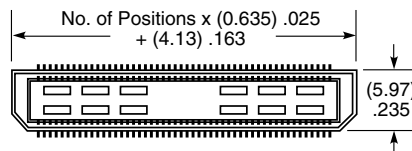

PROCESSING

Lead-Free Solderable:
Yes
SMT Lead Coplanarity:
(0.10 mm) .004" max
Board Stacking:
For applications requiring more than two connectors per board or 100 positions or higher, contact ipg@samtec.com

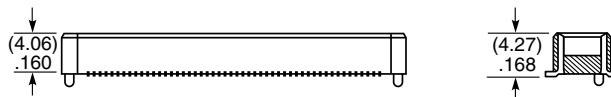

ALSO AVAILABLE

MOQ Required

30 μ" (0.76 μm) Gold
Other platings
Other positions

BSS	NO. OF POSITIONS PER ROW	01	PLATING OPTION	D	A	OTHER OPTION
------------	---------------------------------	-----------	-----------------------	----------	----------	---------------------

-025, -050,
-075, -100

-F
= Gold Flash on contact,
Matte Tin on tail

-L
= 10 μ" (0.25 μm)
Gold on contact,
Matte Tin on tail

-TR
= Tape & Reel
(-100 positions maximum)

-FR
= Full Reel
Tape & Reel
(must order maximum
quantity per reel;
contact Samtec for
quantity breaks)
(-100 positions maximum)

MATED HEIGHT

LEAD STYLE	MATED HEIGHT*
-01	(5.00 mm) .197"

*Processing conditions will affect mated height.

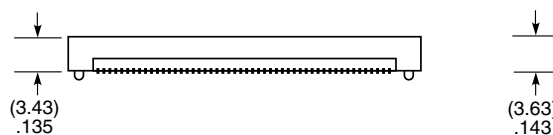
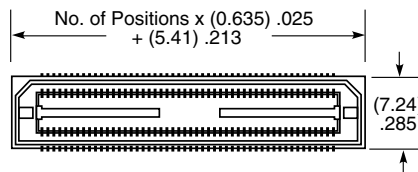

Note:
Some lengths, styles and options are non-standard, non-returnable.

BASIC BLADE & BEAM HEADER & SOCKET

(0.80 mm) .0315" PITCH • BTE/BSE SERIES



BTE
Mates:
BSE

BSE
Mates:
BTE

SPECIFICATIONS

Insulator Material:
Liquid Crystal Polymer
Contact Material:
Phosphor Bronze
Plating:
Au or Sn over 50 μ" (1.27 μm) Ni
Current Rating:
2 A per pin
(2 pins powered)
Operating Temp Range:
-55 °C to +125 °C
Voltage Rating:
225 VAC with 5 mm Stack Height
Max Cycles:
100

PROCESSING

Lead-Free Solderable:
Yes
SMT Lead Coplanarity:
(0.10 mm) .004" max (020-080)
(0.15 mm) .006" max (100-120)*
*(.004" stencil solution may be available; contact IPG@samtec.com)
Board Stacking:
For applications requiring more than two connectors per board or 80 positions or higher, contact ipg@samtec.com

ALSO AVAILABLE

MOQ Required

30 μ" (0.76 μm) Gold
Edge Mount Capability
Friction Lock option
11 mm, 14 mm, 16.10 mm, 19.10 mm, 22 mm, 25 mm and 30 mm Stack Height (Caution: Some automatic placement/inspection machines may have component height restrictions. Please consult machinery specifications.)



Note:
Some lengths, styles and options are non-standard, non-returnable.

BTE	NO. OF POSITIONS PER ROW	LEAD STYLE	PLATING OPTION	D	A	OTHER OPTION
------------	---------------------------------	-------------------	-----------------------	----------	----------	---------------------

-020, -040, -060,
-080, -100, -120

Specify
LEAD
STYLE
from
chart

-F
= Gold Flash on contact,
Matte Tin on tail

-L
= 10 μ" (0.25 μm)
Gold on contact,
Matte Tin on tail

-C*
= Electro-Polished Selective
50 μ" (1.27 μm) min
Au over 150 μ" (3.81 μm)
Ni on Signal Pins in contact
area, Matte Tin over
50 μ" (1.27 μm) min
Ni on all solder tails
(*-C Plating passes
10 year MFG testing)

-K
= (7.00 mm)
.275" DIA
Polyimide Film
Pick & Place Pad

-TR
= Tape & Reel
(80 positions
maximum)

-FR
= Full Reel
Tape & Reel
(must order
maximum
quantity per
reel; contact
Samtec for
quantity breaks)
(80 positions
maximum)

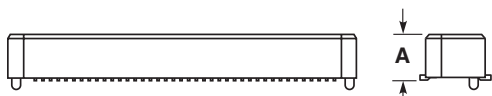
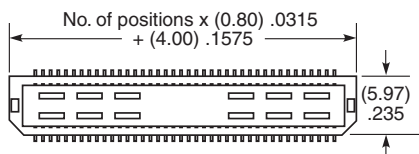

LEAD STYLE	A
-01	(4.27) .168
-02	(7.21) .284

MATED HEIGHT

LEAD STYLE	MATED HEIGHT*
-01	(5.00 mm) .1971"
-02	(8.00 mm) .315"

*Processing conditions will affect mated height.

BSE	NO. OF POSITIONS PER ROW	01	PLATING OPTION	D	A	OTHER OPTION
------------	---------------------------------	-----------	-----------------------	----------	----------	---------------------

-020, -040, -060,
-080, -100, -120

-F
= Gold Flash on contact,
Matte Tin on tail

-L
= 10 μ" (0.25 μm)
Gold on contact,
Matte Tin on tail

-C*
= Electro-Polished Selective
50 μ" (1.27 μm) min
Au over 150 μ" (3.81 μm)
Ni on Signal Pins in contact
area, Matte Tin over
50 μ" (1.27 μm) min
Ni on all solder tails
(*-C Plating passes
10 year MFG testing)

-TR
= Tape & Reel
(80 positions
maximum)

-FR
= Full Reel
Tape & Reel
(must order
maximum
quantity per
reel; contact
Samtec for
quantity breaks)
(80 positions
maximum)

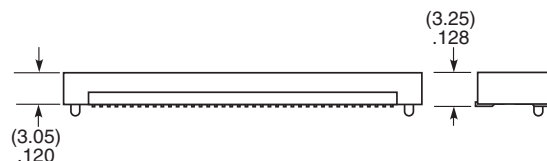
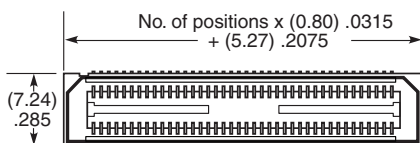

SMT MICRO HEADER & SOCKET

(0.80 mm) .0315" PITCH • FTE/CLE SERIES

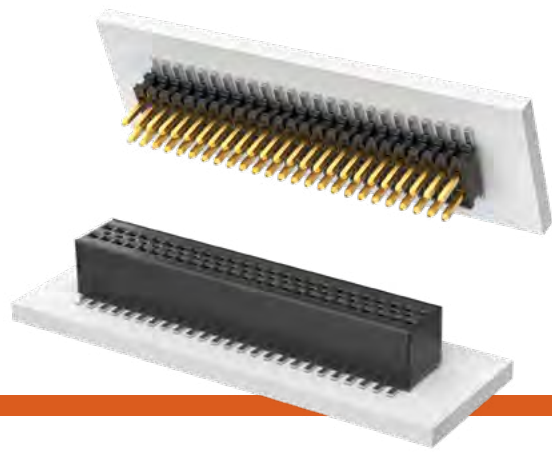

FTE
Mates:
CLE

CLE
Mates:
FTE, AW

SPECIFICATIONS

Insulator Material:
Black Liquid Crystal Polymer
Terminal Material:
Phosphor Bronze
Contact Material:
BeCu
Plating:
Au over 50 μ" (1.27 μm) Ni
Current Rating (FTE/CLE):
2.7 A per pin
(2 pins powered)
Operating Temp Range:
-55 °C to +125 °C
Insertion Depth (CLE):
Top Entry =
(1.73 mm) .068" to (3.18 mm) .125"
with (0.38 mm) .015"
wipe, or pass-through
Bottom Entry =
(3.23 mm) .127" minimum plus
board thickness
Normal Force (CLE):
75 grams (0.73 N)
Max Cycles (CLE):
100 with 10 μ" (0.25 μm) Au

PROCESSING

Lead-Free Solderable:
Yes
SMT Lead Coplanarity (FTE):
-DV: (0.10 mm) .004" max
-DH: (0.10 mm) .004" max (05-25)
(0.15 mm) .006" max (26-50)*
*(.004" stencil solution
may be available; contact
IPG@samtec.com)
SMT Lead Coplanarity (CLE):
(0.10 mm) .004" max (04-65)
(0.15 mm) .006" max (66-90)*
*(.004" stencil solution
may be available; contact
IPG@samtec.com)

Note:
Some lengths, styles and
options are non-standard,
non-returnable.

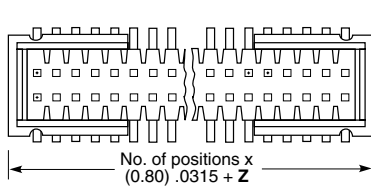
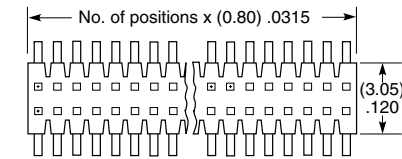
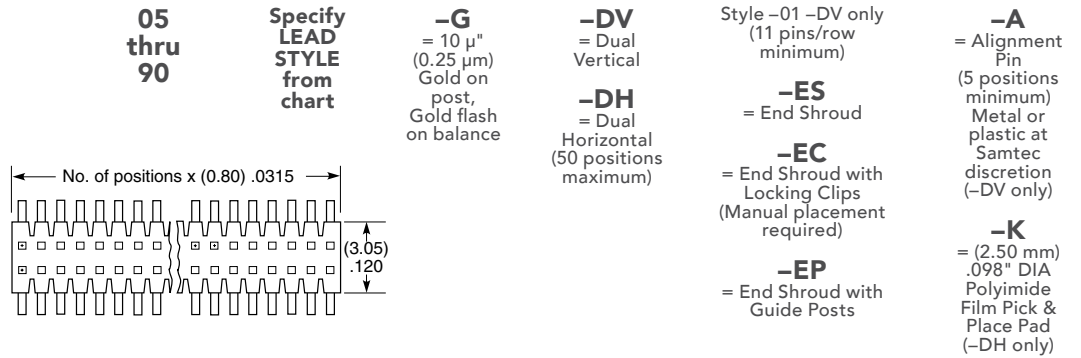

OPTION	Z	LEAD STYLE	A
-ES	(1.57) .062	-01	(1.90) .075
-EC	(4.11) .162	-02	(4.45) .175
-EP	(5.51) .217	-03	(3.05) .120

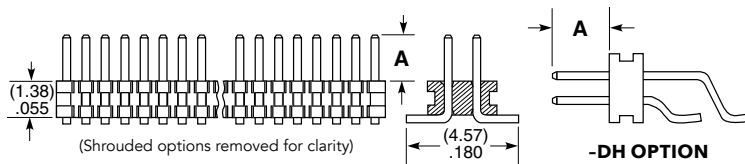

04 thru 90

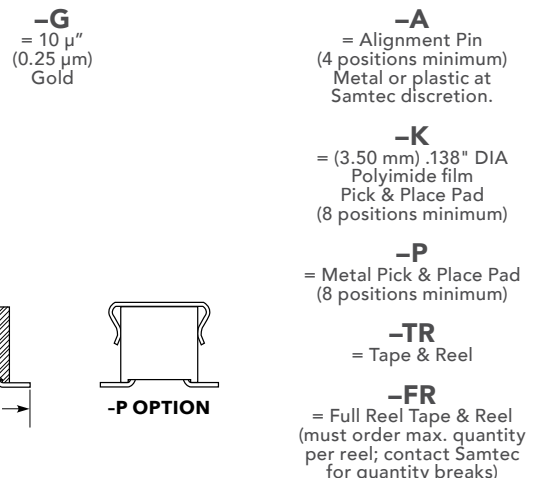
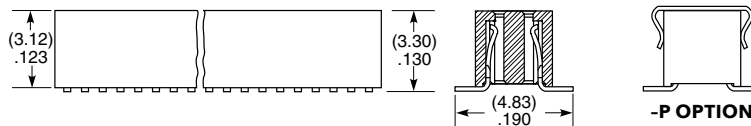
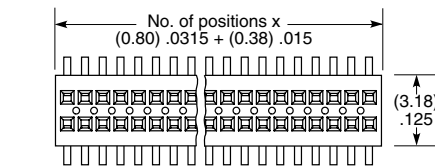

SMT MICRO BOARD STACKER

(0.80 mm) .0315" PITCH • AW SERIES

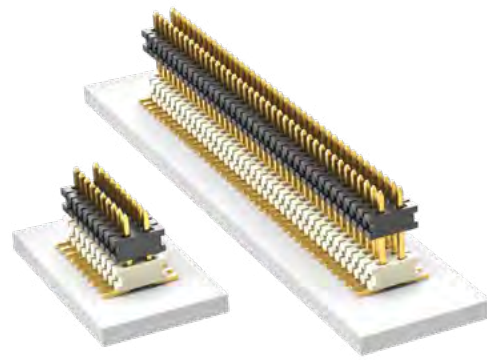

AW
Mates:
CLE

SPECIFICATIONS

Insulator Material:
Top: Black LCP
Bottom: Natural LCP
Terminal Material:
Phosphor Bronze
Plating:
Au over 50 μ " (1.27 μ m) Ni
Operating Temp Range:
-55 °C to +125 °C

PROCESSING

Lead-Free Solderable:
Yes
SMT Lead Coplanarity:
(0.10 mm) .004" max (05-40)
(0.15 mm) .006" max (41-90)*
*(.004" stencil solution
may be available; contact
IPG@samtec.com)

OPTIONS

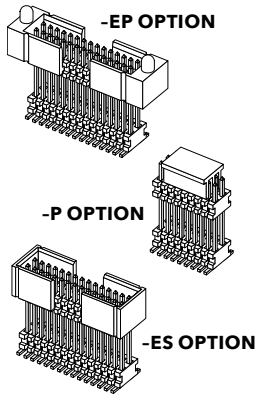

Notes:
For added mechanical stability, Samtec recommends mechanical board spacers be used in applications with gold or selective gold plated connectors. Contact ipg@samtec.com for more information.

Some lengths, styles and options are non-standard, non-returnable.

AW	NO. PINS PER ROW	03	PLATING OPTION	D	STACKER HEIGHT	POST HEIGHT	OTHER OPTION
----	------------------	----	----------------	---	----------------	-------------	--------------

05 thru 90

-G
= 10 μ "
(0.25 μ m)
Gold

-"XXX"
= Stacker Height
(in inches)
(3.09 mm)
.122" to
(5.84 mm)
.230"

Example:
-175
= (4.45 mm)
.175"

-"XXX"
= Post Height
(in inches)
(1.91 mm)
.075"
minimum

Example:
-075
= (1.91 mm)
.075"

-ES
= End Shroud
11 pins/row min.
(-075 Post
Height only)

-EP
= End Shroud
with Guide Post
(-075 Post
Height only)
11 pins/row min.

-A
= Alignment Pin
(4 positions min.)
(Available for
board stacks
between
(4.06 mm) .160" to
(5.84 mm) .230")
(Metal or plastic at
Samtec discretion.)

-P
= Pick & Place Pad
(8 positions min.)

-TR
= Tape & Reel
(84 positions max.)

-FR
= Full Reel
Tape & Reel
(must order max.
quantity per reel;
contact Samtec for
quantity breaks)
(84 positions max.)

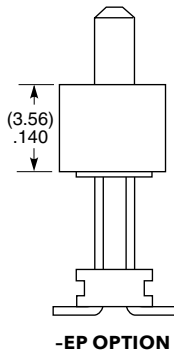
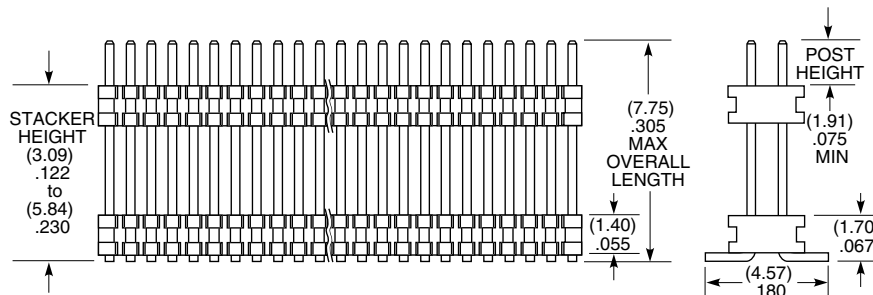
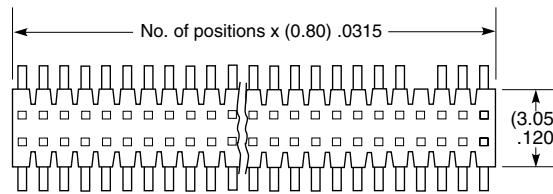

-EP OPTION

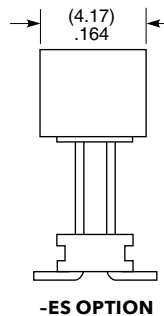

-ES OPTION

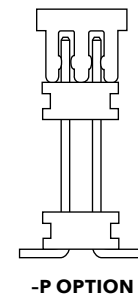

-P OPTION

SMT MICRO TERMINAL STRIPS

(1.00 mm) .0394" PITCH • FTMH/FTM SERIES

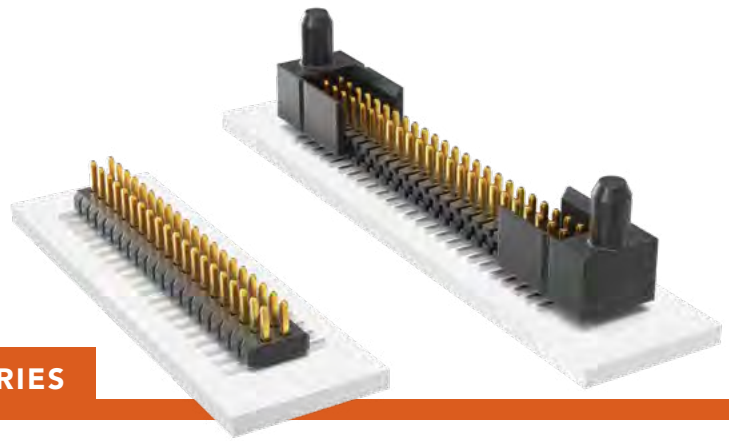

FTMH
Mates:
CLM, MLE

FTM
Mates:
CLM, MLE

FTMH	1	NO. PINS PER ROW	LEAD STYLE	PLATING OPTION	ROW OPTION	FLEX SHROUD OPTION	OTHER OPTION
------	---	------------------	------------	----------------	------------	--------------------	--------------

05
thru
50

-02
= (1.91 mm)
.075" Post
(Mates with MLE)

-F
= Gold flash
on post,
Matte Tin
on tail

-DV
= Dual
Vertical

(-DV only with
9 pins/row
minimum)

-A
= Alignment Pin
(3 positions min.)
Metal or plastic at
Samtec discretion
(-DV only)

-ES
= End Shroud

-DH
= Dual
Horizontal

-EC
= End Shroud
with Locking Clip
(Manual placement
required)

-K
= (2.50 mm)
.098" DIA
Polyimide Film
Pick & Place Pad
(-DH only)

-EP
= End Shroud
with Guide Post
(Use only when
mating with CLM)

-P
= Plastic Pick
& Place Pad
(6 positions min.)
(-DV only)

-TR
= Tape & Reel

-FR
= Full Reel
Tape & Reel
(must order max.
quantity per reel;
contact Samtec for
quantity breaks)

SPECIFICATIONS

Insulator Material:

Black Liquid Crystal
Polymer

Terminal Material:

Phosphor Bronze

Plating:

Sn or Au over
50 μ" (1.27 μm) Ni

Current Rating (FTMH/CLM):

2.8 A per pin
(2 pins powered)

Operating Temp Range:

-55 °C to +125 °C

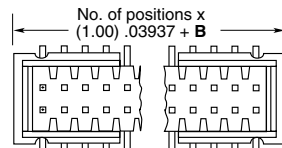
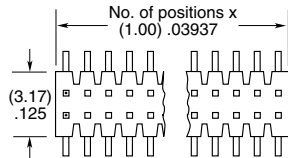

OPTION	B
-ES	(1.57) .062
-EC	(4.06) .160
-EP	(5.49) .216

PROCESSING

Lead-Free Solderable:

Yes

SMT Lead Coplanarity:

-DV: (0.10 mm) .004" max

-DH: (0.10 mm) .004" max (05-25)

(0.15 mm) .006" max (26-50)*

*(.004" stencil solution
may be available; contact
IPG@samtec.com)

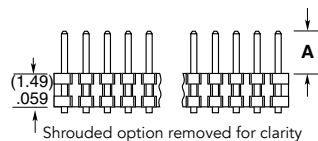

-DV OPTION

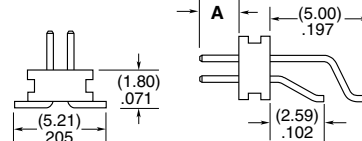

-DH OPTION

LEAD STYLE	A
-02	(1.91) .075
-03	(1.65) .065

ALSO AVAILABLE

MOQ Required

End shrouds with board locks

Molded end shrouds for
05 through 08 positions

Other platings

FTM	1	NO. PINS PER ROW	LEAD STYLE	PLATING OPTION	DV	FLEX SHROUD OPTION	OTHER OPTION
-----	---	------------------	------------	----------------	----	--------------------	--------------

02 thru 50
= Unshrouded

-02
= (1.91 mm)
.075" Post
(Mates with MLE)

-F
= Gold flash
on post,
Matte Tin
on tail

-S
= End Shroud
(05 positions
minimum).
Molded or
press-fit shroud
at Samtec's
discretion

-P
= Plastic Pick
& Place Pad
(7 positions min.)

-TR
= Tape & Reel

-FR
= Full Reel
Tape & Reel
(must order max.
quantity per reel;
contact Samtec for
quantity breaks)

05 thru 46
= Shrouded

-03
= (1.65 mm)
.065" Post
(Mates with CLM)

-L
= 10 μ"
(0.25 μm)
Gold
on post,
Matte Tin
on tail

-SA
= End Shroud with
Alignment Pins
(05 through 46
positions)

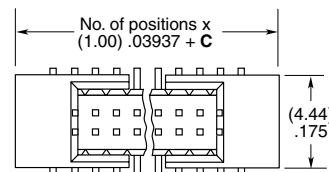
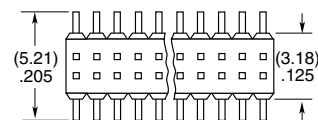

OPTION	C
-S	(7.00) .276
-SA	(4.00) .157

LEAD STYLE	D
-02	(1.91) .075
-03	(1.65) .065

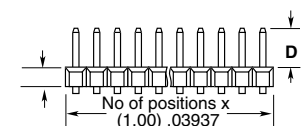

Shrouded options removed for clarity



Note:
Some lengths, styles and
options are non-standard,
non-returnable.

FLEX STACK

SMT MICRO BOARD HEADER

(1.00 mm) .0394" PITCH • MW SERIES

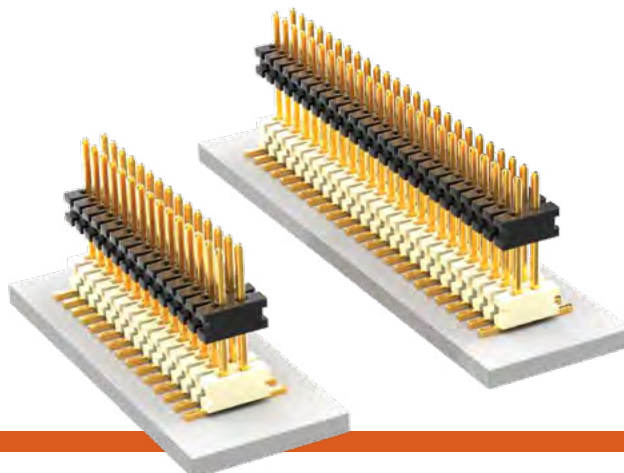

MW

Mates:

CLM, MLE

SPECIFICATIONS

Insulator Material:

Top: Black LCP
Bottom: Natural LCP

Terminal Material:

Phosphor Bronze

Plating:

Au over 50 μ" (1.27 μm) Ni

Operating Temp Range:

-55 °C to +125 °C

PROCESSING

Lead-Free Solderable:

Yes

SMT Lead Coplanarity:

(0.10 mm) .004" max (02-30)

(0.15 mm) .006" max (31-50)*

*(.004" stencil solution

may be available; contact

IPG@samtec.com)

MW	NO. PINS PER ROW	03	PLATING OPTION	D	STACKER HEIGHT	POST HEIGHT	OPTION
	02 thru 50		-G = 10 μ" (0.25 μm) Gold		-"XXX" = Stacker Height (in inches) (2.41 mm) .095" to (6.22 mm) .245" Example: -245 = (6.22 mm) .245"	-"XXX" = Post Height (in inches) (1.65 mm) .065" minimum Example: -065 = (1.65 mm) .065"	-A = Alignment Pin (5 positions minimum) Metal or plastic at Samtec's discretion -P = Pick & Place Pad (7 positions minimum) -TR = Tape & Reel -FR = Full Reel Tape & Reel (must order maximum quantity per reel; contact Samtec for quantity breaks)

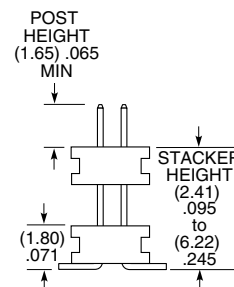
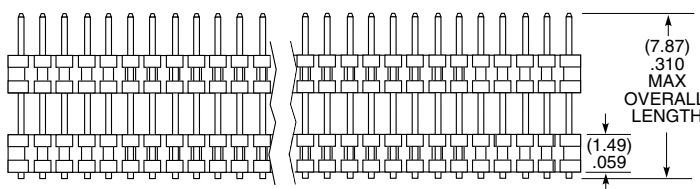
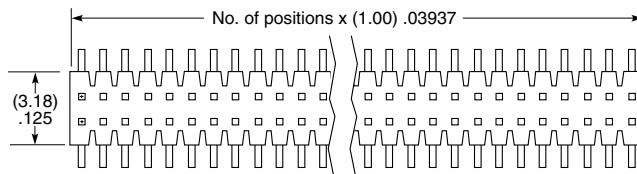

ALSO AVAILABLE

MOQ Required

End shrouds

End shrouds with
guide posts

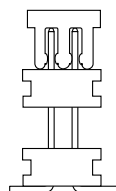
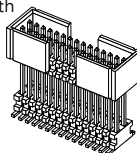

-P OPTION

APPLICATION

EXAMPLES		
LEAD STYLE		MATED HEIGHT*
MW	CLM	
-163-065	-02	(6.35 mm) .250"
-233-065		(8.13 mm) .320"

*Processing conditions will affect mated height.

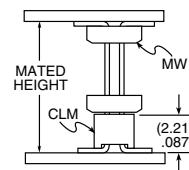

Notes:

For added mechanical stability, Samtec recommends mechanical board spacers be used in applications with gold or selective gold plated connectors. Contact ipg@samtec.com for more information.

This Series is non-standard, non-returnable.

RUGGED RELIABLE MICRO SOCKETS

(1.00 mm) .0394" PITCH • CLM/MLE SERIES

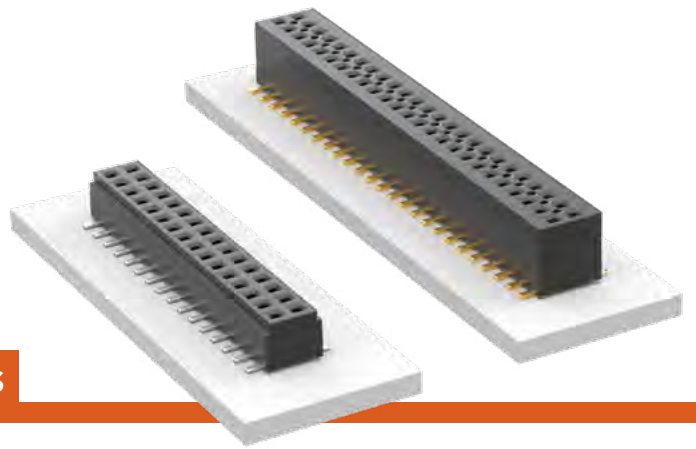

CLM

Mates:
FTM, FTMH, MW

MLE

Mates:
FTM, FTMH, MW

SPECIFICATIONS

Insulator Material: Black LCP
Contact Material:
 CLM: Phosphor Bronze
 MLE: BeCu
Plating:
 CLM: Au or Sn over
 50 μ " (1.27 μ m) Ni
 MLE: Au over 10 μ " (0.25 μ m) Ni
Current Rating (CLM/FTM):
 2.8 A per pin
 (2 pins powered)
Current Rating (MLE/FTM):
 2.9 A per pin (2 pins powered)
Operating Temp Range:
 -55 °C to +125 °C
Max Cycles:
 CLM: 100 with 10 μ " (0.25 μ m) Au
Voltage Rating:
 MLE: 310 VAC
Insertion Depth:
 CLM:
 Top Entry = (1.40 mm) .055" min.,
 Bottom Entry =
 (2.41 mm) .095" min.
 (Add board thickness for
 correct post OAL)
 MLE:
 (1.63 mm) .064" to
 (3.18 mm) .125" with
 (0.38 mm) .015" wipe,
 pass-through, or (2.44 mm) .096"
 minimum for bottom entry
Normal Force:
 CLM: 40 grams (0.39 N) average

PROCESSING

Lead-Free Solderable: Yes
SMT Lead Coplanarity:
 (0.10 mm) .004" max (02-25)
 (0.15 mm) .006" max (26-50)*
 *(.004" stencil solution
 may be available; contact
 IPG@samtec.com)

ALSO AVAILABLE

MOQ Required

Alignment pin
 Other Gold plating options



Note:
 Some lengths, styles and
 options are non-standard,
 non-returnable.



02 thru 50

-F
 = Gold flash on
 contact,
 Matte Tin on tail

-L
 = 10 μ " (0.25 μ m)
 Gold on contact,
 Matte Tin on tail

-BE
 = Bottom Entry
 (Required for bottom entry)

-K
 = (3.50 mm) .138" DIA
 Polyimide film
 Pick & Place Pad
 (7 positions minimum)

-P
 = Pick & Place Pad
 (7 positions minimum)

-PA
 = Pick & Place Pad with
 integral Alignment Pin

-TR
 = Tape & Reel

-FR
 = Full Reel Tape & Reel
 (must order maximum
 quantity per reel;
 contact Samtec for
 quantity breaks)

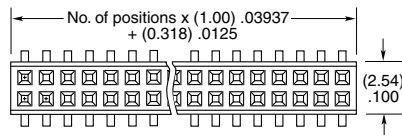

PIN/ROW	A
04-15	(3.56) .140
16-50	(7.11) .280

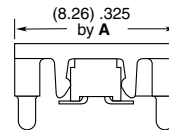

-PA

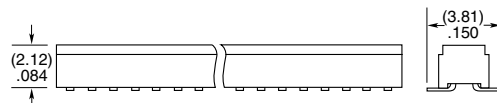

-P



02 thru 50

-G
 = 10 μ "
 (0.25 μ m)
 Gold

-A
 = Alignment Pin
 (3 positions minimum)
 Metal or plastic
 at Samtec discretion

-K
 = (4.00 mm) .1575" DIA
 Polyimide film
 Pick & Place Pad
 (5 positions minimum)

-P
 = Metal Pick & Place Pad
 (5 positions minimum)

-TR
 = Tape & Reel

-FR
 = Full Reel Tape & Reel
 (must order maximum
 quantity per reel;
 contact Samtec for
 quantity breaks)

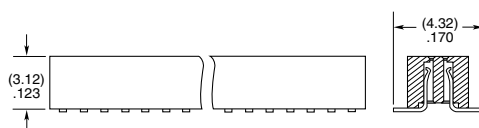
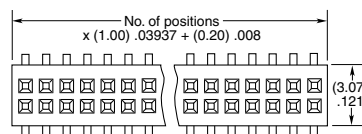

-P

-A

QUAD ROW SMT TERMINAL & SOCKET

(1.27 mm) .050" PITCH • TOLC/SOLC SERIES



TOLC
Mates:
SOLC

SOLC
Mates:
TOLC

SPECIFICATIONS

Insulator Material:
Black Liquid Crystal Polymer
Contact Material:
Phosphor Bronze
Plating:
Au over 50 μ" (1.27 μm) Ni
Current Rating:
2.4 A per pin
(6 adjacent pins powered)
Operating Temp Range:
-55 °C to +125 °C
Insertion Depth (SOLC):
(1.68 mm) .066" to
(3.61 mm) .142" with
(0.38 mm) .015" wipe
Normal Force (SOLC):
75 grams (0.74 N) average
Max Cycles (SOLC):
100+

PROCESSING

Lead-Free Solderable:
Yes
SMT Lead Coplanarity:
(0.10 mm) .004" max (05-35)
(0.15 mm) .006" max (40-50)*
*(.004" stencil solution
may be available; contact
IPG@samtec.com)

ALSO AVAILABLE
MOQ Required

Other sizes
Other platings

Note:
Some lengths, styles and
options are non-standard,
non-returnable.

TOLC	1	NO. PINS PER ROW	LEAD STYLE	PLATING OPTION	Q	OTHER OPTION
-------------	----------	-------------------------	-------------------	-----------------------	----------	---------------------

05, 10, 15, 20, 25,
30, 35, 40, 45, 50
(Standard Sizes)

Specify
LEAD
STYLE
from
chart

-F
= Gold flash
on contact,
Gold flash
on tail
-L
= 10 μ"
(0.25 μm)
Gold on
contact,
Gold flash
on tail

-A
= Alignment Pin
(N/A with -LC)
-LC
= Locking Clip
(N/A with -A)
(Manual
placement required)
-K
= (9.00 mm) .354" DIA
Polyimide film
Pick & Place Pad

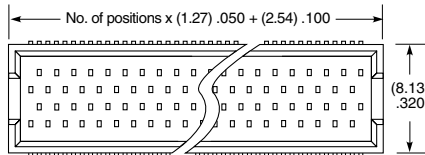

LEAD STYLE	A	MATED HEIGHT
-02	(5.59) .220	(6.35) .250
-12	(7.24) .285	(8.00) .315
-22	(9.25) .364	(10.00) .394
-32	(11.23) .442	(12.00) .472

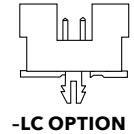
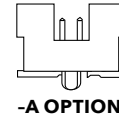
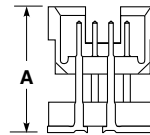
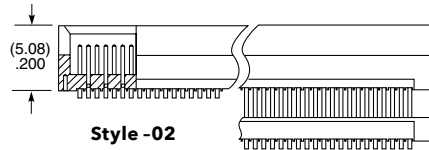

SOLC	1	NO. PINS PER ROW	02	PLATING OPTION	Q	OTHER OPTION
-------------	----------	-------------------------	-----------	-----------------------	----------	---------------------

05, 10, 15, 20, 25,
30, 35, 40, 45, 50
(Standard Sizes)

-F
= Gold flash
on contact,
Gold flash
on tail
-L
= 10 μ"
(0.25 μm)
Gold on contact,
Gold flash
on tail

-A
= Alignment Pin
(N/A with -LC)
-LC
= Locking Clip
(N/A with -A)
(Manual
placement required)
-K
= (7.00 mm) .276" DIA
Polyimide film
Pick & Place Pad

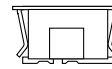
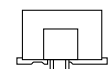
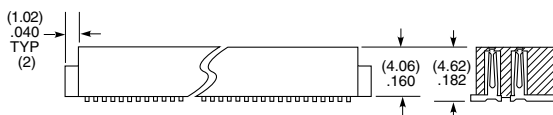
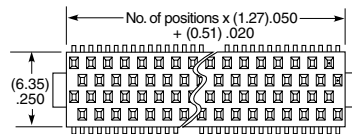

-P
= Pick & Place Pad
-TR
= Tape & Reel
-FR
= Full Reel Tape & Reel
(must order max.
quantity per reel;
contact Samtec for
quantity breaks)

SURFACE MOUNT MICRO HEADER

(1.27 mm) .050" PITCH • FTSH SERIES

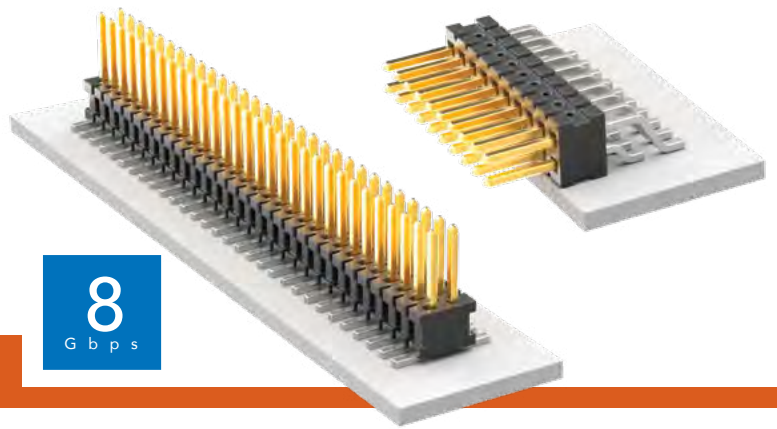

FTSH

Board Mates:
CLP, FLE

Cable Mates:
FFSD, FFTP

SPECIFICATIONS

Insulator Material:
Black Liquid Crystal Polymer

Terminal Material:
Phosphor Bronze

Plating:
Sn or Au over

50 μ" (1.27 μm) Ni

Current Rating (FTSH/CLP):
3.4 A per pin

(2 pins powered)

Operating Temp Range:
-55 °C to +125 °C

PROCESSING

Lead-Free Solderable:
Yes

SMT Lead Coplanarity:

-MT & -DV Tail Option:
(0.10 mm) .004" max (02-25)

-MT & -DH Tail Option:
(0.15 mm) .006" max (26-50)*

*(.004" stencil solution

may be available; contact

IPG@samtec.com)

ALSO AVAILABLE

MOQ Required

Molded Pick & Place pads

Latches

Other platings



Notes:

Some sizes, styles and options are non-standard, non-returnable.

See SFM/TFM for positive alignment feature.

FTSH	1	NO. PINS PER ROW	LEAD STYLE	PLATING OPTION	TAIL OPTION	OPTION	FLEX SHROUD OPTIONS	OTHER OPTIONS
------	---	------------------	------------	----------------	-------------	--------	---------------------	---------------

02
thru
50

-01
= (3.05 mm)
.120" Post
(Mates with
FFSD)

-02
= (1.91 mm)
.075" Post
(Mates with
FLE)

-03
= (1.65 mm)
.065" Post
(Mates with
CLP-D)

-04
= (3.81 mm)
.150" Post
(Mates with
CLP-DH)

-05
= (4.32 mm)
.170" Post
(Mates with
CLP-BE)

-F
= Gold flash
on post,
Matte Tin
on tail

-L
= 10 μ"
(0.25 μm)
Gold
on post,
Matte Tin
on tail

-DV
= Double
Vertical

-DH
= Double
Horizontal
(Styles
-01, -02 &
-04 only)

-MT
= Mixed
Technology
(Styles
-01, -02 &
-04 only)

Leave Blank
for -DH &
-MT

"XXX"
= Polarized
Position
(Specify
position
of
omitted
pin)
(Not
available
with -EX
options)

(Style -02 & -03
only, -DH & -MT
not available)
9 pins/row
minimum
(Other positions
available. Call
Samtec.)

-ES
= End Shroud

-EC
= End Shroud
with Locking Clip
(Manual
placement
required)

-EP
= End Shroud
with Guide Post

-EL
= End Shroud with
Board Lock
(Boards are
positively locked
and cannot be
unmated)

-EJ
= Ejector Shroud
(Style -01 only)
-DH & -MT
not available
10 pins/row
minimum
25 pins/row
maximum

-K
= Keying
Shroud
(For mating
with FFSD
Style -01 only
and 05, 08, 10,
13, 15, 17,
20 & 25
pins/row only.
13, 17, 20 & 25
pins/row only
with -EJ option)
(-DV only)

-A
= Alignment
Pin
(-DV 3 positions
minimum)
(-DH 5 positions
minimum)
(Metal or
plastic at
Samtec
discretion)

-C
= (5.00 mm)
.197" DIA
Polyimide film
Pick & Place Pad
(-DH only)

-P
= Pick &
Place Pad
(-DV 4 positions
minimum)
(-DH & -MT
not available)

-TR
= Tape & Reel
(Flex Shroud
options
not available
except -ES
& -EJ)

-FR
= Full Reel
Tape & Reel
(must order
maximum
quantity
per reel;
contact
Samtec for
quantity breaks)

OPTION	Z
-ES	(2.57) .101
-EJ	(15.77) .621
-EC	(3.33) .131
-EP	(5.87) .231
-EL	(6.53) .257

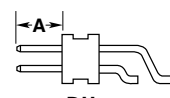
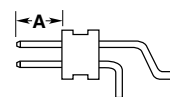
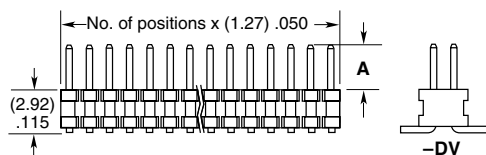
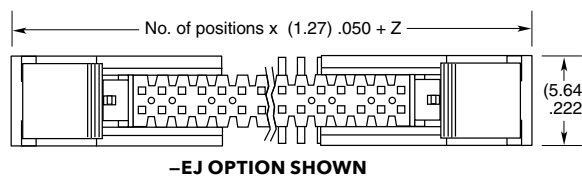
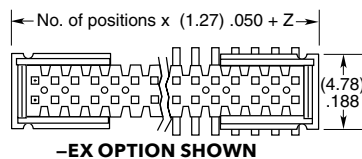

LEAD STYLE	A
-01	(3.05) .120
-02	(1.91) .075
-03	(1.65) .065
-04	(3.81) .150
-05	(4.32) .170

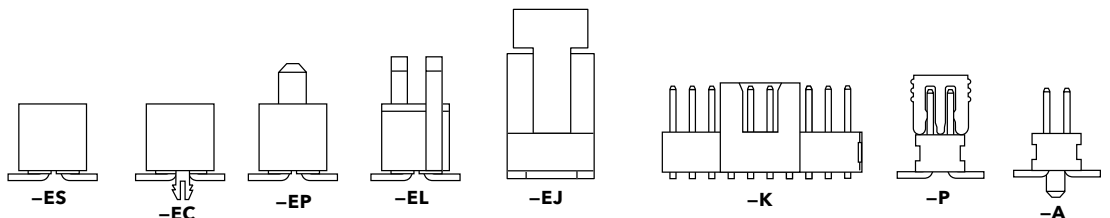

THROUGH-HOLE MICRO HEADER

(1.27 mm) .050" PITCH • FTSH SERIES

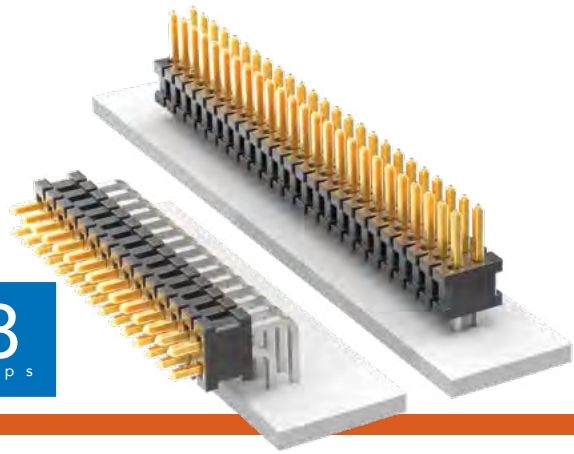

FTSH

Board Mates:
CLP, FLE

Cable Mates:
FFSD, FFTP

SPECIFICATIONS

Insulator Material:
Black Liquid Crystal Polymer
Terminal Material:
Phosphor Bronze
Plating:
Sn or Au over 50 μ" (1.27 μm) Ni
Current Rating (FTSH/CLP):
3.4 A per pin
(2 pins powered)
Operating Temp Range:
-55 °C to +125 °C

PROCESSING

Lead-Free Solderable:
Yes

LOCKING CLIP

For single mating cycle with the FFSD. Specify -LC after tail option. Lead Style -01 and 10 pins/row minimum. 5-9 pins/row not available in combination with keying shroud (-K).

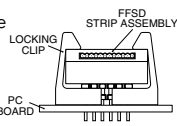

ALSO AVAILABLE

MOQ Required

Molded Pick & Place pads
Other platings



Notes:

Some sizes, styles and options are non-standard, non-returnable.

See SFM/TFM for positive alignment feature.

FTSH	1	NO. PINS PER ROW	LEAD STYLE	PLATING OPTION	D	OPTION	TAIL OPTION	OTHER OPTIONS
------	---	------------------	------------	----------------	---	--------	-------------	---------------

02 thru 50

Specify LEAD STYLE from chart

-F
= Gold flash on post, Matte Tin on tail

-L
= 10 μ" (0.25 μm) Gold on post, Matte Tin on tail

Leave blank for Right-angle

-"XXX"
= Polarized Position (Specify position of omitted pin) (Not available with -EX options)

Leave blank for straight tail

-RA
= Right-angle

-ES
= End Shroud (Style -02 & -03) 9 pins/row minimum

-EP
= End Shroud with Guide Post (Style -02 & -03) 9 pins/row minimum

-EL
= End Shroud with Board Lock (Style -02 & -03) 9 pins/row minimum

-EJ
= Ejector Shroud (Style -01 only) 10 pins/row minimum 25 pins/row maximum -RA not available

-K
= Keying Shroud for mating with FFSD (Style -01 only, 05, 08, 10, 13, 15, 17, 20 & 25 pins/row only and 13, 17, 20 & 25 only with -EJ option)

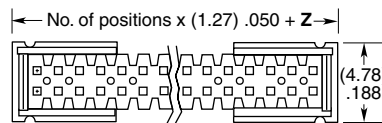

-EX OPTION SHOWN

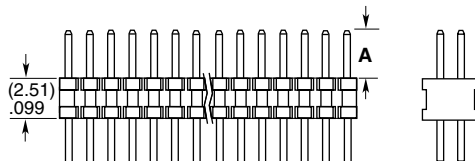

OPTION	Z
-ES	(1.55) .061
-EJ	(15.77) .621
-EP	(5.87) .231
-EL	((6.53) .257

LEAD STYLE	A	MATES WITH
-01	(3.05) .120	FFSD
-02	(1.91) .075	FLE
-03	(1.65) .065	CLP-D
-04	(3.81) .150	N/A

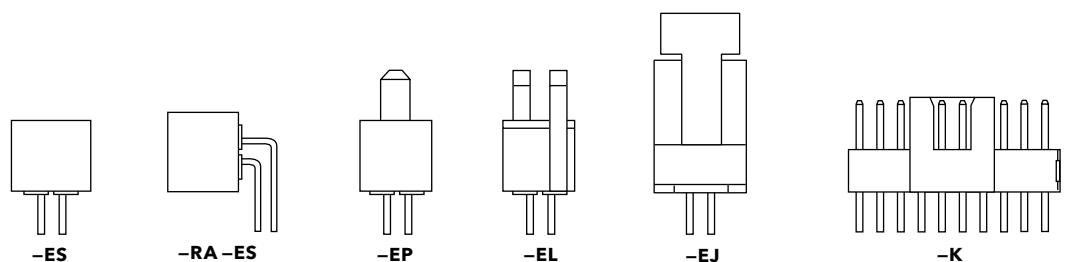
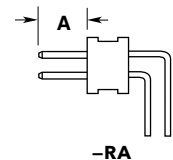

MICRO LOW-PROFILE TERMINAL STRIPS

(1.27 mm) .050" PITCH • FTS SERIES

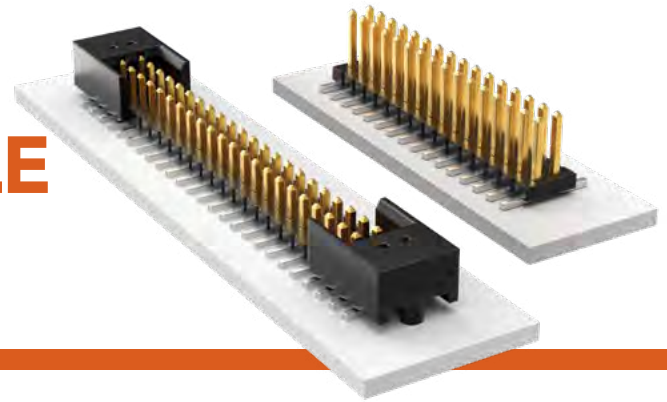

FTS

Board Mates:
CLP, FLE

Cable Mates:
FFSD

SPECIFICATIONS

Insulator Material:
Black Liquid Crystal Polymer

Terminal Material:
Phosphor Bronze

Operating Temp Range:
-55 °C to +125 °C

Plating:
Sn or Au over 50 μ" (1.27 μm) Ni

Current Rating:
3.4 A per pin
(2 pins powered)

PROCESSING

Lead-Free Solderable:
Yes

SMT Lead Coplanarity:
.004" (0.10 mm) max

ALSO AVAILABLE

Alignment pin
(MOQ Required)

OPTIONS

-TR OPTION

-SA OPTION

-P OPTION

-S OPTION

FTS	1	NO. PINS PER ROW	LEAD STYLE	PLATING OPTION	ROW OPTION	OTHER OPTION
-----	---	------------------	------------	----------------	------------	--------------

02 thru 50
(except -S & -SA
option = 05 thru 46)

-01
= (3.05 mm)
.120" Post
(Mates with FFSD)

-02
= (1.91 mm)
.075" Post
(Mates with FLE)

-03
= (1.65 mm)
.065" Post
(Mates with CLP)

-04
= (3.81 mm)
.150" Post

-F
= Gold flash
on post,
Matte Tin
on tail

-L
= 10 μ"
(0.25 μm)
Gold on post,
Matte Tin
on tail

-D
= Double
Through-hole

-DV
= Double
Vertical SMT

-S
= Single
Through-hole

-SV
= Single
Vertical SMT

(-D & -DV only)

-SA
= End Shroud
with Alignment Pin
(05 thru 46 positions.
Style -02 & -03 only)

-S
= End Shroud
(05 thru 46 positions.
Style -02 & -03 only)

-P
= Pick & Place Pad
(04 positions min.)

-TR
= Tape & Reel
(-DV only)
(Required callout for
positions 02 thru 04)

-FR
= Full Reel
Tape & Reel
(must order max.
quantity per reel;
contact Samtec for
quantity breaks)
(-DV only)

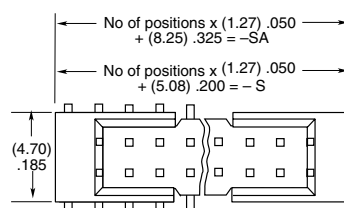
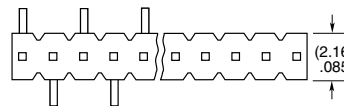
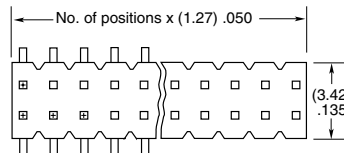

LEAD STYLE	A
-01	(3.05) .120
-02	(1.91) .075
-03	(1.65) .065
-04	(3.81) .150

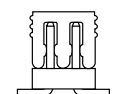
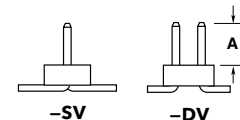
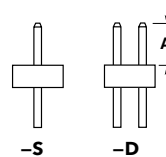
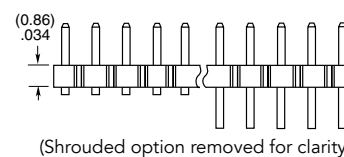

-P OPTION

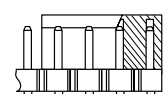

-S OPTION

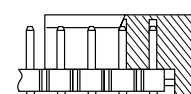

-SA OPTION

Note:
Some lengths, styles and
options are non-standard,
non-returnable.

FLEX STACK

MICRO BOARD STACKER

(1.27 mm) .050" PITCH • FW SERIES

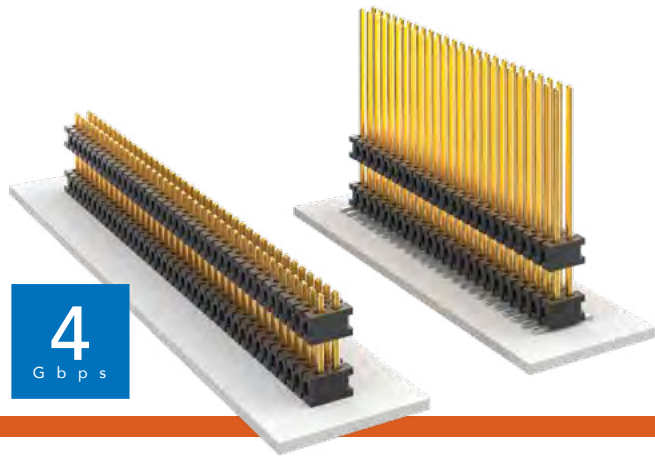

FW

Board Mates:

CLP, FLE

Cable Mates:

FFSD

SPECIFICATIONS

Insulator Material:

Black Liquid Crystal Polymer

Terminal Material:

Phosphor Bronze

Plating:

Sn or Au over 50 μ" (1.27 μm) Ni

Operating Temp Range:

-55 °C to +125 °C

PROCESSING

Lead-Free Solderable:

Yes

SMT Lead Coplanarity:

(0.10 mm) .004" max (02-30)

(0.15 mm) .006" max (31-50)*

*(.004" stencil solution

may be available; contact

IPG@samtec.com)

MATED HEIGHT

FW LEAD STYLE	CLP LEAD STYLE	MATED HEIGHT*
FW-XX-03-X-X-233-065	-02	8.13 mm) .329"
FW-XX-03-X-X-303-065		9.91 mm) .390"

*Processing conditions will affect mated height.

ALSO AVAILABLE

Smaller stack heights
(MOQ Required)

Notes:

For added mechanical stability, Samtec recommends mechanical board spacers be used in applications with gold or selective gold plated connectors. Contact ipg@samtec.com for more information.

This Series is non-standard, non-returnable.

FW	NO. OF PINS PER ROW	LEAD STYLE	PLATING OPTION	D	STACKER HEIGHT	POST HEIGHT	OPTION
----	---------------------	------------	----------------	---	----------------	-------------	--------

02 thru 50

Specify LEAD STYLE from chart

-F
= Gold flash on post, Matte Tin on tail

-L
= 10 μ" (0.25 μm)
Gold on post, Matte Tin on tail

-G
= 10 μ" (0.25 μm)
Gold on post, Gold flash on tail

-"XXX"
= Stacker Height (in inches)

Example:
-250
= (6.35 mm) .250"

-"XXX"
= Post Height (in inches)

(1.65 mm) .065" minimum

Example:
-.065
= (1.65 mm) .065"

-ES
= End Shroud (-075 post height only. Mate only with CLP) (5.46 mm) .215" to (15.49 mm) .610" stacker height only 9 pins/row min.

-EP
= End Shroud with Guide Post (-075 post height only. Mate only with CLP) (5.46 mm) .215" to (15.49 mm) .610" stacker height only 9 pins/row min.

-A
= Alignment Pin (3 positions min.) (5.46 mm) .215" to (15.75 mm) .620" stacker height only (SMT only)

-P
= Pick & Place Pad (5 positions min.) (SMT only)

-TR
= Tape & Reel (Max overall height = Post+Stacker Height+Pad+Alignment Pin = (17.78) .700") (SMT only)

-FR
= Full Reel Tape & Reel (must order max. quantity per reel; contact Samtec for quantity breaks) (SMT only)

LEAD STYLE	STACKER HEIGHT	STACKER + POST
-03	(5.46) to (8.51) .215 to .335	(7.11) to (10.16) .280 to .400
-05	(8.64) to (15.49) .340 to .610	(10.29) to (17.15) .405 to .675

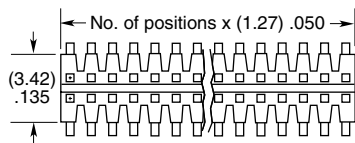

SURFACE MOUNT

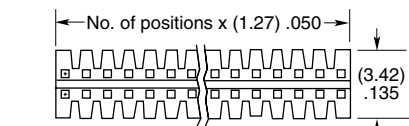
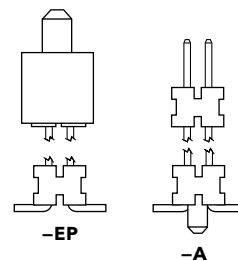
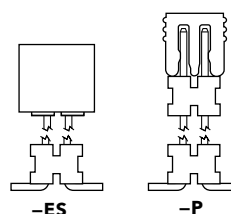
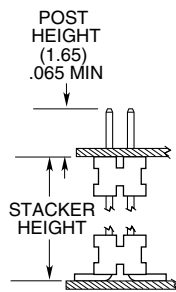
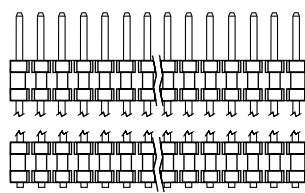

THROUGH-HOLE

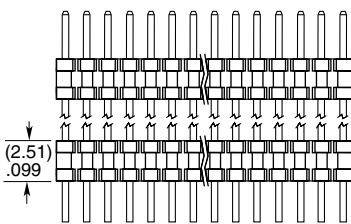

POST HEIGHT (1.65) .065 MIN

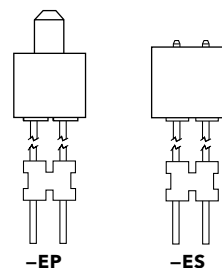
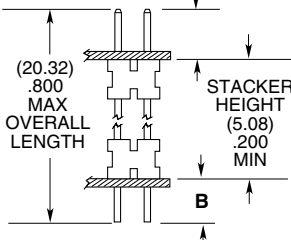

LEAD STYLE	TAIL (B)
-01	(1.14) .045
-02	(1.91) .075
-04	(2.29) .090

LOW-PROFILE DUAL WIPE SOCKET

8
Gbps

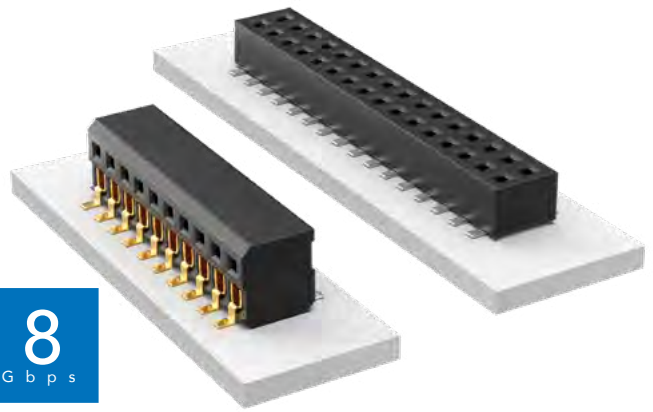

(1.27 mm) .050" PITCH • CLP SERIES

CLP

Mates:
FTSH, FTS, FW



SPECIFICATIONS

Insulator Material:
Black Liquid Crystal Polymer
Contact Material:
Phosphor Bronze
Plating:
Sn or Au over
50 μ" (1.27 μm) Ni
Current Rating (CLP/FTSH):
3.4 A per pin
(2 pins powered)
Voltage Rating:
280 VAC/395 VDC
Operating Temp Range:
-55 °C to +125 °C
Insertion Depth:
Top Entry =
(1.40 mm) .055" minimum
Bottom Entry =
(2.41 mm) .095" minimum
plus board thickness
DH Entry =
(2.31 mm) .091" to (2.67 mm) .105"
Normal Force:
60 grams (0.59 N) average
Max Cycles:
100 with 10 μ" (0.25 μm) Au

PROCESSING

Lead-Free Solderable:
Yes
SMT Lead Coplanarity:
(0.10 mm) .004" max (02-35)
(0.15 mm) .006" max (36-50)*
*(.004" stencil solution
may be available; contact
IPG@samtec.com)

ALSO AVAILABLE

MOQ Required

Single row
Other platings

02 thru 50

-F
= Gold flash
on contact,
Matte Tin
on tail

-L
= 10 μ"
(0.25 μm)
Gold on
contact,
Matte Tin
on tail

-G
= 10 μ"
(0.25 μm)
Gold
(-D only)

-D
= Double
Row

-DH
= Double
Horizontal
(Requires
FTSH-04
lead style)

-BE
= Bottom Entry
(Required for bottom
entry applications)

-A
= Alignment Pin
(Not available with -PA option)
(05, 06, 07, 08, 10, 12, 15,
20, 25, 30, 40 positions only)
(-DH option and other sizes.
Contact Samtec.)

-K
= (4.00 mm) .157" DIA
Polyimide film Pick & Place Pad
(5 positions minimum)

-P
= Pick & Place Pad
(5 positions min. -D only)
(Not always necessary
for auto placement.
See Flex Processing.)

-PA
= Pick & Place Pad
with Alignment Pin
(-D only)
(Not available with -A option)

-TR
= Tape & Reel

-FR
= Full Reel Tape & Reel
(must order maximum
quantity per reel;
contact Samtec for
quantity breaks)

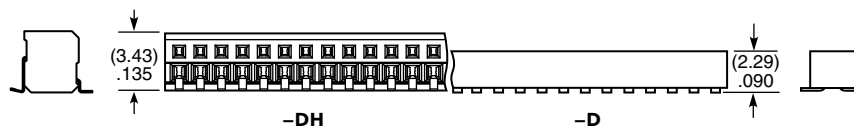
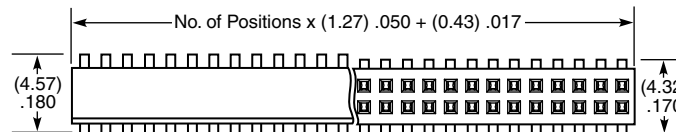

PIN/ROW	A
04-15	(3.56) .140
16-50	(7.11) .280

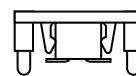
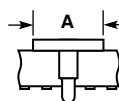

-PA OPTION



-P OPTION

If odd pins/row, alignment pins are on middle position on centerline of the part.
If even pins/row, then alignment pins are between middle two positions.

Note:
Some lengths, styles and
options are non-standard,
non-returnable.

COST-EFFECTIVE RELIABLE SOCKET

(1.27 mm) .050" PITCH • FLE SERIES

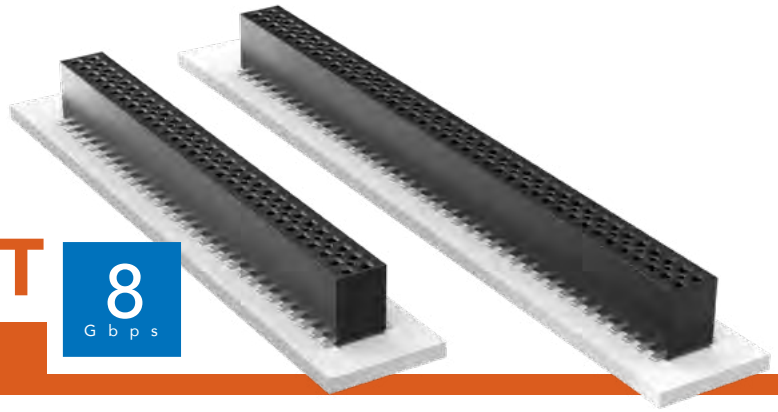

FLE

Board Mates:
FTSH, FTS, FW

Cable Mates:
FFMD*, FMTP

***Note:**
Standard FFMD callout will not mate with FLE, SFMC. Must use gold plated callouts. (See drawing on web.)



02 thru 50

-G
= 10 μ" (0.25 μm) Gold

-A
= Alignment Pin
(Metal or plastic at Samtec discretion)
(3 positions minimum)

-K
= (4.25 mm) .167" DIA
Polyimide film
Pick & Place Pad
(5 positions minimum)

-P
= Metal Pick & Place Pad
(5 positions minimum)

-TR
= Tape & Reel

-FR
= Full Reel Tape & Reel
(must order maximum quantity per reel; contact Samtec for quantity breaks)

SPECIFICATIONS

Insulator Material:
Black Liquid Crystal Polymer

Contact Material:
Phosphor Bronze

Plating:
Au over 50 μ" (1.27 μm) Ni

Current Rating:
2.9 A per pin
(2 pins powered)

Operating Temp Range:
-55 °C to +125 °C

Insertion Depth:
(1.83 mm) .072" to (4.37 mm)
.172" or pass-through

Normal Force:
100 grams (0.98 N)

Max Cycles:
100+

PROCESSING

Lead-Free Solderable:
Yes

SMT Lead Coplanarity:
(0.10 mm) .004" max

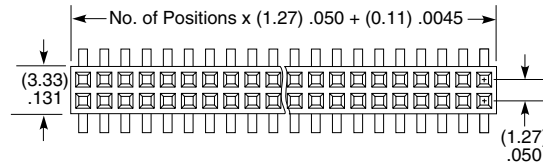

ALSO AVAILABLE

Other Plating
(MOQ Required)

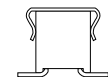
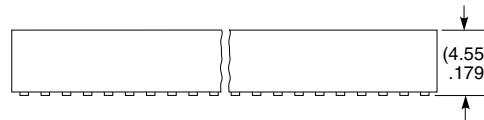

-P OPTION



Note:
Some lengths, styles and options are non-standard, non-returnable.

THROUGH-HOLE MICRO HEADER

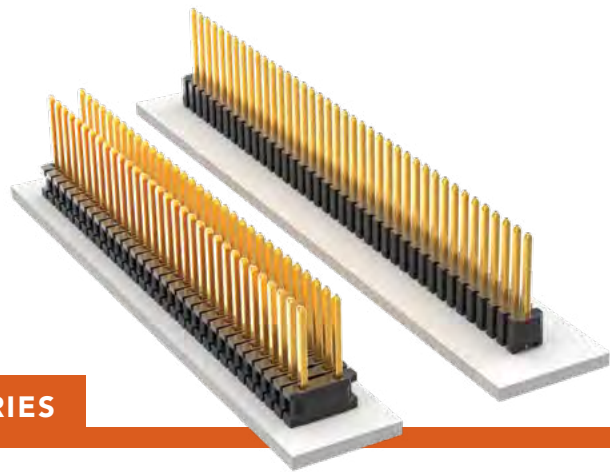

(1.27 mm) .050" PITCH • TMS/HTMS SERIES

TMS/HTMS

Mates:
SMS, SLM, RSM

SPECIFICATIONS

Insulator Material:
Black Liquid Crystal Polymer

Terminal Material:
Phosphor Bronze

Plating:

Au or Sn over
50 μ" (1.27 μm) Ni

Current Rating (TMS/SMS):

5 A per pin
(2 pins powered)

Operating Temp Range:

-55 °C to +105 °C with Tin;
-55 °C to +125 °C with Gold

PROCESSING

Lead-Free Solderable:

Yes

SERIES	1	NO. PINS PER ROW	01 thru 50	LEAD STYLE	Specify LEAD STYLE from chart	PLATING OPTION	-L = 10 μ" (0.25 μm) Gold on post, Matte Tin on tail	-G = 10 μ" (0.25 μm) Gold on post, Gold flash on tail	ROW OPTION	-S = Single Row	-D = Double Row	OPTION	-RA = Right- angle	-"XXX" = Polarized Position (Specify position of omitted pin)
--------	---	------------------	------------	------------	-------------------------------	----------------	---	--	------------	-----------------------	-----------------------	--------	--------------------------	---

TMS
= Standard

HTMS
= High Temp

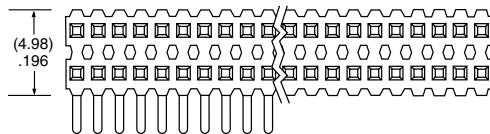
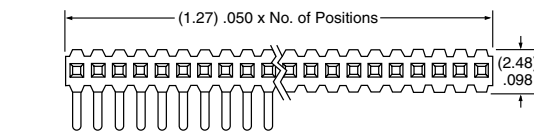

T/H LEAD STYLE	A	B	C
-01	(11.43) .450	(5.84) .230	(3.05) .120
-02	(8.13) .320	(2.54) .100	
-21	(12.83) .505	(5.84) .230	(4.45) .175
-51	(10.41) .410	(4.83) .190	
-52	(10.80) .425	(5.21) .205	
-53	(12.83) .505	(7.24) .285	
-54	(14.10) .555	(8.51) .335	
-55	(15.49) .610	(9.91) .390	(3.05) .120
-56	(15.88) .625	(10.29) .405	
-57	(16.51) .650	(10.92) .430	
-58	(17.91) .705	(12.32) .485	
-59	(19.18) .755	(13.59) .535	
-60	(20.96) .825	(15.37) .605	

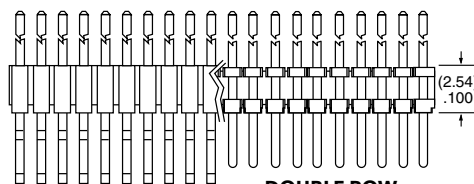

SINGLE ROW

DOUBLE ROW

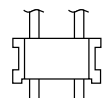
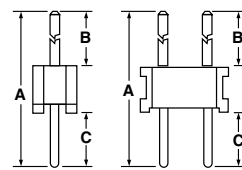

HTMS
-D
BODY
DESIGN

ALSO AVAILABLE

Other Plating
(MOQ Required)

Important Note:

Style -02 does not mate
with SMS Series.

RA LEAD STYLE	D
-01	(5.84) .230
-02	(2.54) .100
-03	(3.18) .125

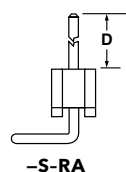

-S-RA

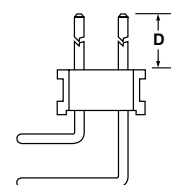

-D-RA

Note:

Some lengths, styles and
options are non-standard,
non-returnable.

FLEX STACK

SHROUDED HEADERS & STACKERS

(1.27 mm) .050" PITCH • TML/ZML SERIES



TML/ZML

Mates:
SMS, RSM

SPECIFICATIONS

TML

Insulator Material:
Black Liquid Crystal Polymer
Insulation Resistance:
5000 MΩ min
Terminal Material:
Phosphor Bronze
Plating:
Au or Sn over
50 μ" (1.27 μm) Ni
Operating Temp Range:
-55 °C to +105 °C with Tin;
-55 °C to +125 °C with Gold

ZML

Insulator Material:
Black Liquid Crystal Polymer
Terminal Material:
Phosphor Bronze
Plating:
Au or Sn over
50 μ" (1.27 μm) Ni
Operating Temp Range:
-55 °C to +105 °C with Tin;
-55 °C to +125 °C with Gold

PROCESSING

TML

Lead-Free Solderable:
Yes
SMT Lead Coplanarity:
(0.10 mm) .004" max (05-20)
(0.15 mm) .006" max (32)*
*(.004" stencil solution
may be available; contact
IPG@samtec.com)

ZML

Same as TML except:
SMT Lead Coplanarity:
(0.15 mm) .006" max*
*(.004" stencil solution
may be available; contact
IPG@samtec.com)

ALSO AVAILABLE

MOQ Required

Other sizes
Other platings

Notes:

For added mechanical stability, Samtec recommends mechanical board spacers be used in applications with gold or selective gold plated connectors. Contact ipg@samtec.com for more information.

Some sizes, styles and options are non-standard, non-returnable.

TML	1	NO. PINS PER ROW	LEAD STYLE	PLATING OPTION	D	TAIL OPTION	OTHER OPTION								
		05, 08, 10, 20, 32 (Standard sizes)	Specify LEAD STYLE from chart	-L = 10 μ" (0.25 μm) Gold on post, Matte Tin on tail -G = 10 μ" (0.25 μm) Gold on post, Gold flash on tail		(Leave blank for Through-hole) -RA = Right-angle -SM = Surface Mount (For locking clip add -LC)	- "XXX" = Polarized position (Specify position of omitted pin)								
						<table border="1"> <thead> <tr> <th>LEAD STYLE</th> <th>POST HEIGHT (A)</th> </tr> </thead> <tbody> <tr> <td>-01</td> <td>(3.05) .120</td> </tr> <tr> <td>-02</td> <td>(5.84) .230</td> </tr> <tr> <td>-03</td> <td>(4.32) .170</td> </tr> </tbody> </table>		LEAD STYLE	POST HEIGHT (A)	-01	(3.05) .120	-02	(5.84) .230	-03	(4.32) .170
LEAD STYLE	POST HEIGHT (A)														
-01	(3.05) .120														
-02	(5.84) .230														
-03	(4.32) .170														
						<p>THROUGH-HOLE</p> <p>SURFACE MOUNT</p> <p>RIGHT-ANGLE</p>									

ZML	1	NO. PINS PER ROW	LEAD STYLE	PLATING OPTION	D	BODY HEIGHT	TAIL OPTION															
		05, 08, 10, 20, 32 (Standard sizes)	Specify LEAD STYLE from chart	-L = 10 μ" (0.25 μm) Gold on post, Matte Tin on tail -G = 10 μ" (0.25 μm) Gold on post, Gold flash on tail		(Leave blank for Through-hole) - "XXX" = -SM Body Height (Specify board space "B" in inches from lead style charts.) -SM = Surface Mount	(Leave blank for Through-hole)															
						<table border="1"> <thead> <tr> <th>THROUGH-HOLE</th> <th>LEAD STYLE</th> <th>BODY HEIGHT (C)</th> </tr> </thead> <tbody> <tr> <td></td> <td>-01</td> <td>(12.83) .505</td> </tr> <tr> <td></td> <td>-02</td> <td>(14.22) .560</td> </tr> <tr> <td></td> <td>-03</td> <td>(16.64) .655</td> </tr> <tr> <td></td> <td>-04</td> <td>(19.69) .775</td> </tr> </tbody> </table>		THROUGH-HOLE	LEAD STYLE	BODY HEIGHT (C)		-01	(12.83) .505		-02	(14.22) .560		-03	(16.64) .655		-04	(19.69) .775
THROUGH-HOLE	LEAD STYLE	BODY HEIGHT (C)																				
	-01	(12.83) .505																				
	-02	(14.22) .560																				
	-03	(16.64) .655																				
	-04	(19.69) .775																				
						<table border="1"> <thead> <tr> <th colspan="3">SURFACE MOUNT</th> </tr> <tr> <th>LEAD STYLE</th> <th>POST HEIGHT (A)</th> <th>BODY HEIGHT (B)</th> </tr> </thead> <tbody> <tr> <td>-53</td> <td>(3.05) .120</td> <td>(13.46) .530 to (20.19) .795</td> </tr> <tr> <td>-54</td> <td>(5.84) .230</td> <td>(13.46) .530 to (17.40) .685</td> </tr> </tbody> </table>		SURFACE MOUNT			LEAD STYLE	POST HEIGHT (A)	BODY HEIGHT (B)	-53	(3.05) .120	(13.46) .530 to (20.19) .795	-54	(5.84) .230	(13.46) .530 to (17.40) .685			
SURFACE MOUNT																						
LEAD STYLE	POST HEIGHT (A)	BODY HEIGHT (B)																				
-53	(3.05) .120	(13.46) .530 to (20.19) .795																				
-54	(5.84) .230	(13.46) .530 to (17.40) .685																				
				<p>THROUGH-HOLE</p>		<p>SURFACE MOUNT</p>																

MICRO BOARD STACKER

(1.27 mm) .050" PITCH • DWM/HDWM SERIES

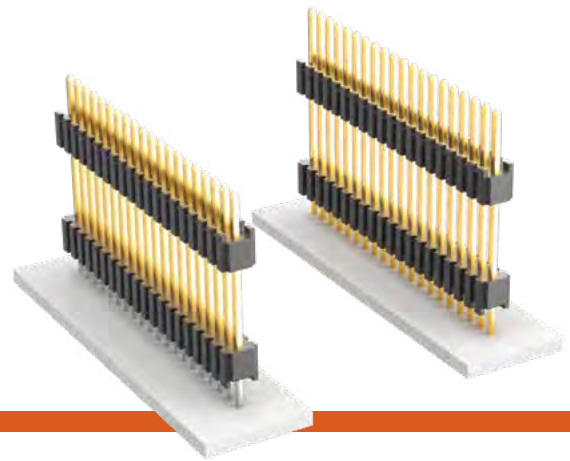

DWM/HDWM

Mates:
SMS, SLM, RSM

SPECIFICATIONS

Insulator Material:
Liquid Crystal Polymer
Terminal Material:
Phosphor Bronze
Plating:
Au or Sn over 50 μ" (1.27 μm) Ni
Operating Temp Range:
-55 °C to +105 °C with Tin
-55 °C to +125 °C with Gold

PROCESSING

Lead-Free Solderable:
Yes
SMT Lead Coplanarity:
(0.15 mm) .006" max*
*(.004" stencil solution may be available; contact IPG@samtec.com)

ALSO AVAILABLE

Other Platings
(MOQ Required)

DWM	NO. PINS PER ROW	LEAD STYLE	PLATING OPTION	ROW OPTION	STACKER HEIGHT	OTHER OPTION
	01 thru 50	Specify LEAD STYLE from chart	-L = 10 μ" (0.25 μm) Gold on contact, Matte Tin on tail -G = 10 μ" (0.25 μm) Gold on contact, Gold flash on tail	-S = Single Row -D = Double Row	- "XXX" = Stacker Height Example: -200 = (5.08 mm) .200"	- "XXX" = Polarized Position (Specify position of omitted pin)

OAL	
LEAD STYLE	THROUGH-HOLE
-01	(11.43) .450
-51	(10.41) .410
-52	(10.80) .425
-53	(12.83) .505
-54	(14.10) .555
-55	(15.49) .610
-56	(15.88) .625
-57	(16.51) .650
-58	(17.91) .705
-59	(19.18) .755
-60	(20.96) .825
-61	(26.67) 1.050

HDWM	NO. PINS PER ROW	LEAD STYLE	PLATING OPTION	ROW OPTION	STACKER HEIGHT	OTHER OPTION
	01 thru 50	Specify LEAD STYLE from chart	-L = 10 μ" (0.25 μm) Gold on contact, Matte Tin on tail -G = 10 μ" (0.25 μm) Gold on contact, Gold flash on tail	-S = Single Row -D = Double Row	- "XXX" = Stacker Height Example: -250 = (6.35 mm) .250"	- "XXX" = Polarized Position (Specify position of omitted pin) - SM = Surface Mount (02 thru 40 positions only) - A = Alignment Pin (6 positions minimum -D only) Metal or plastic at Samtec discretion (Not available with -LC) - LC = Locking Clip (5 positions minimum -D only) (Not available with -A) (Manual placement required) - P = Pick & Place Pad

OAL		
LEAD STYLE	THROUGH-HOLE	SURFACE MOUNT
-01	(11.43) .450	(8.38) .330
-51	(10.41) .410	—
-52	(10.80) .425	—
-53	(12.83) .505	(9.78) .385
-54	(14.10) .555	(11.05) .435
-55	(15.49) .610	(12.45) .490
-56	(15.88) .625	(12.83) .505
-57	(16.51) .650	(13.46) .530
-58	(17.91) .705	(14.86) .585
-59	(19.18) .755	(15.62) .615
-60	(20.96) .825	—
-61	(26.67) 1.050	—

Notes:
For added mechanical stability, Samtec recommends mechanical board spacers be used in applications with gold or selective gold plated connectors. Contact ipg@samtec.com for more information.

This Series is non-standard, non-returnable.

SMT MICRO HEADER & SOCKET

(1.27 mm) .050" PITCH • FTR/RSM SERIES

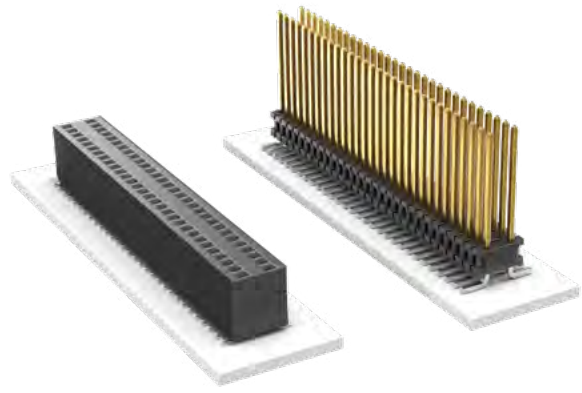

FTR
Mates:
RSM, SMS, SLM

RSM
Mates:
FTR, HTMS, HDWM,
DWM, TML, ZML, TMS

SPECIFICATIONS

Insulator Material:
Black Liquid Crystal Polymer
Contact Material:
RSM: Phosphor Bronze
Terminal Material:
FTR: Phosphor Bronze
Plating:
Au or Sn over
50 μ " (1.27 μ m) Ni
Current Rating (FTR/RSM):
3.1 A per pin
(2 pins powered)
Operating Temp Range:
FTR: -55 °C to +105 °C with Tin;
FTR: -55 °C to +125 °C with Gold
RSM: -55 °C to +125 °C
Lead Size Accepted:
RSM: (0.46 mm) .018" SQ
Insertion Depth:
RSM: Top Entry =
(2.64 mm) .104" to (5.84 mm) .230"
with (0.38 mm) .015" wipe, or
pass-through.
RSM: Bottom Entry =
(5.49 mm) .216" minimum
(Add board thickness for
correct post OAL)

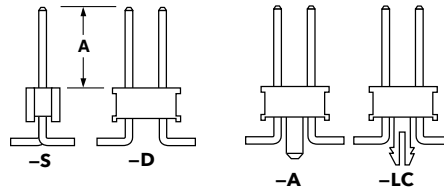
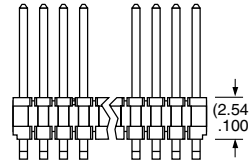
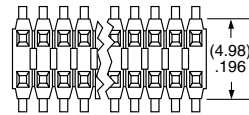
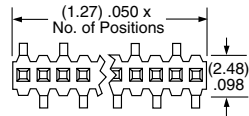

FTR	1	NO. PINS PER ROW	LEAD STYLE	PLATING OPTION	ROW OPTION	OPTION
------------	----------	-------------------------	-------------------	-----------------------	-------------------	---------------

02 thru 40

Specify
LEAD
STYLE
from
chart

-L
= 10 μ " (0.25 μ m)
Gold on post,
Matte Tin on tail

-G
= 10 μ " (0.25 μ m)
Gold on post,
Gold flash on tail

-S
= Single Row
-D
= Double Row

LEAD STYLE	A
-01	(5.84) .230
-02	(2.54) .100
-03	(3.18) .125
-51	(4.83) .190
-52	(5.21) .205
-53	(7.24) .285
-54	(8.51) .335
-55	(9.91) .390
-56	(10.29) .405
-57	(10.92) .430

-XX
= Polarized

-A
= Alignment Pin
(5 positions min. for -D)
(Metal or plastic
at Samtec discretion)
(Not available with -LC)
-LC
= Locking Clip
(6 positions min. for -D)
(Not available with -A)
(Manual placement required)

-P
= Plastic Pick & Place Pad
(5 positions min. for -D)
(8 positions min. for -S)

-TR
= Tape & Reel
(4 positions min. for -S)

-FR
= Full Reel Tape & Reel
(must order max. quantity
per reel; contact Samtec
for quantity breaks)
(4 positions min. for -S)

PROCESSING

Lead-Free Solderable:
Yes
SMT Lead Coplanarity:
RSM: (0.10 mm) .004" max
FTR: (0.10 mm) .004" max (02-20)
FTR: (0.15 mm) .006" max (21-40)*
*(.004" stencil solution
may be available; contact
IPG@samtec.com)

RSM	1	NO. PINS PER ROW	02	PLATING OPTION	ROW OPTION	OPTION
------------	----------	-------------------------	-----------	-----------------------	-------------------	---------------

02 thru 36

-L
= 10 μ " (0.25 μ m)
Gold on contact,
Matte Tin on tail

-S
= Single Row
-D
= Double Row

-K
= (6.25 mm) .246" DIA
Polyimide film
Pick & Place Pad
(5 positions
minimum for -D)
(7 positions
minimum for -S)

-P
= Plastic Pick & Place Pad
(5 positions
minimum for -D)
(6 positions
minimum for -S)

-TR
= Tape & Reel

-FR
= Full Reel Tape & Reel
(must order max.
quantity per reel;
contact Samtec
for quantity breaks)

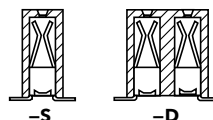
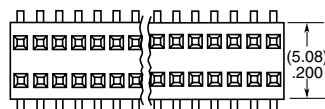
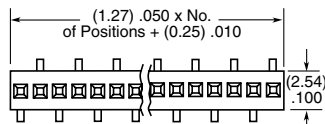

ALSO AVAILABLE
MOQ Required

Other platings
Locking clips

Note:
Some lengths, styles and
options are non-standard,
non-returnable.

THROUGH-HOLE MICRO SOCKETS

(1.27 mm) .050" PITCH • SLM/SMS SERIES

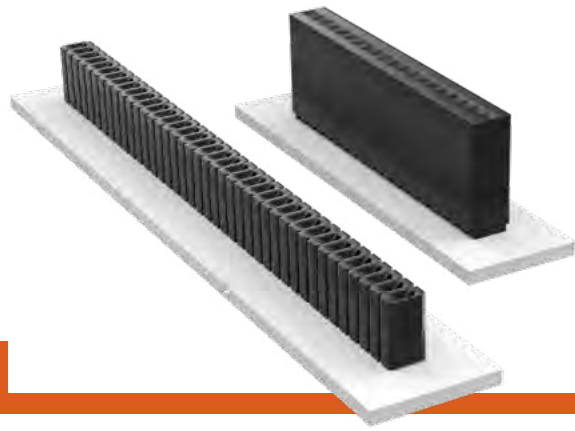

SLM

Mates:
HTMS, TMS, MTMS, DWM,
HDWM, FTR, HMTMS

SMS

Mates:
HTMS, TMS, MTMS,
DWM, HDWM, FTR, TML,
ZML, HMTM

SPECIFICATIONS

Insulator Material:
SLM: Black Glass Filled Polyester
SMS: Black LCP

Contact Material:
Phosphor Bronze

Plating:
Au or Sn over
50 μ" (1.27 μm) Ni

Current Rating (SLM/TMS):
5.2 A per pin
(2 pins powered)

Current Rating (SMS/TMS):
5.0 A per pin
(2 pins powered)

Operating Temp Range:
-55 °C to +125 °C with Gold
-55 °C to +105 °C with Tin

Insertion Depth:
SLM: (2.03 mm) .080"
to (3.05 mm) .120"
SMS: (3.43 mm) .135" to
(6.35 mm) .250" with
(0.38 mm) .015" wipe

PROCESSING

Lead-Free Solderable:
SLM: No, Lead Wave Only
SMS: Yes

ALSO AVAILABLE

Other Platings
(MOQ Required)

Note:
Some lengths, styles and
options are non-standard,
non-returnable.

SLM	-	1	NO. PINS PER ROW	-	01	PLATING OPTION	-	ROW OPTION
-----	---	---	------------------	---	----	----------------	---	------------

01 thru 50

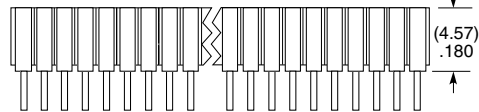
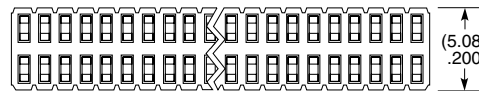
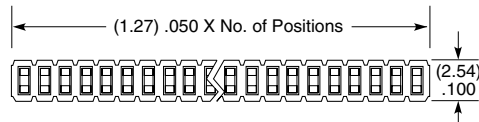

-L
= 10 μ" (0.25 μm) Gold on contact,
Matte Tin on tail

-G
= 20 μ" (0.51 μm) Gold on contact,
Gold flash on balance

-S
= Single Row

-D
= Double Row

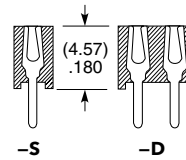

SMS	-	1	NO. PINS PER ROW	-	LEAD STYLE	PLATING OPTION	-	ROW OPTION
-----	---	---	------------------	---	------------	----------------	---	------------

01 thru 50

Specify
LEAD
STYLE
from
chart

-L
= 10 μ" (0.25 μm) Gold on contact,
Matte Tin on tail

-G
= 20 μ" (0.51 μm) Gold on contact,
Gold flash on balance

-S
= Single Row

-D
= Double Row

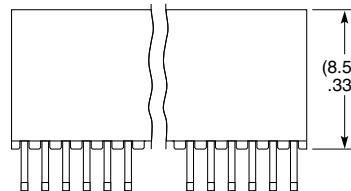
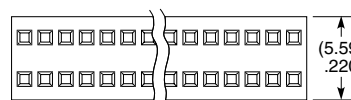
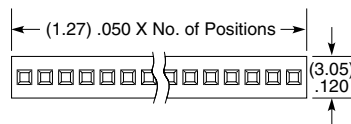

LEAD STYLE	A
-01	(2.54) .100
-02	(4.83) .190

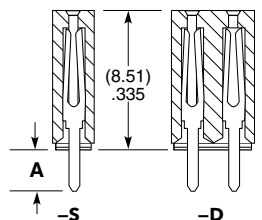

LOW-PROFILE SMT HEADER

(2.00 mm) .0787" PITCH • TMM SERIES

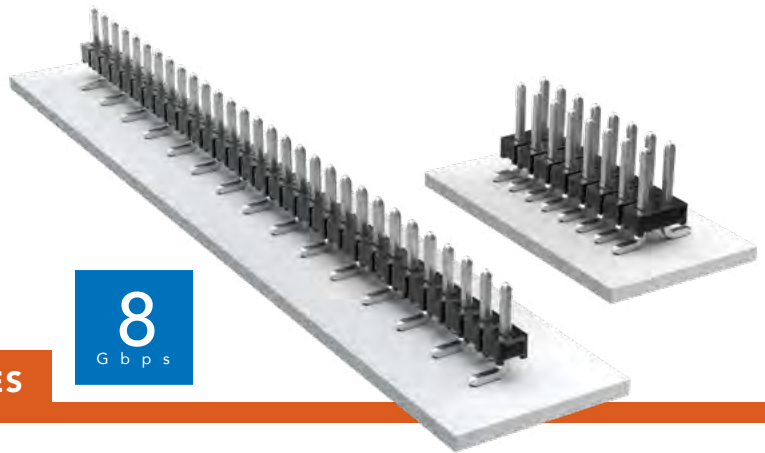

TMM

Board Mates:

CLT, SQT, SQW, ESQT, TLE, SMM, MMS

Cable Mates:

TCSD

SPECIFICATIONS

Insulator Material:

Black Liquid Crystal Polymer

Terminal Material:

Phosphor Bronze

Plating:

Sn or Au over
50 μ" (1.27 μm) Ni

Current Rating:

3.2 A per pin
(2 pins powered)

Operating Temp Range:

-55 °C to +105 °C with Tin;
-55 °C to +125 °C with Gold

Voltage Rating:

281 VAC mated with SQW;
250 VAC mated with SQT

PROCESSING

Lead-Free Solderable:

Yes

SMT Lead Coplanarity:

(0.15 mm) .006" max*
*(.004" stencil solution may be available; contact IPG@samtec.com)

ALSO AVAILABLE

Other plating
(MOQ Required)



TMM	-	1	-	NO. PINS PER ROW	-	LEAD STYLE	-	PLATING OPTION	-	ROW OPTION	-	SM	-	OTHER OPTION
-----	---	---	---	------------------	---	------------	---	----------------	---	------------	---	----	---	--------------

02 thru 40

Specify LEAD STYLE from chart

-F
= Gold flash on post, Matte Tin on tail

-L
= 10 μ" (0.25 μm) Gold on post, Matte Tin on tail

-S
= 30 μ" (0.76 μm) Gold on post, Matte Tin on tail

-T
= Matte Tin

-S
= Single Row

-D
= Double Row

-A
= Alignment Pin (Metal or plastic at Samtec's discretion) (5 positions minimum) (-D only)

-"XXX"
= Polarized Position (Specify position of omitted pin)

-P
= Pick & Place Pad (3 positions minimum)

-TR
= Tape & Reel (3 thru 36 positions only)

-FR
= Full Reel Tape & Reel (must order max. quantity per reel; contact Samtec for quantity breaks) (3 thru 36 positions only)

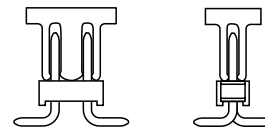
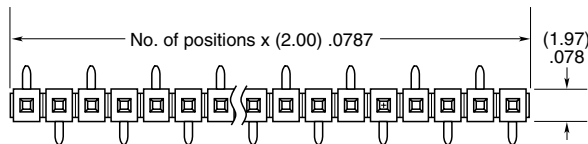

-P

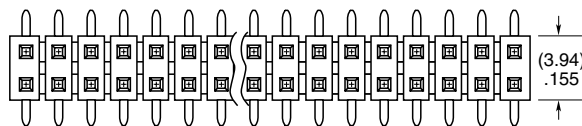

LEAD STYLE	A	MATES WITH
-01	(3.20) .126	SQT, SQW, ESQT, TLE, SMM, MMS, TCSD
-04	(1.91) .075	CLT
-05	(1.65) .065	
-06	(4.27) .168	CLT-BE

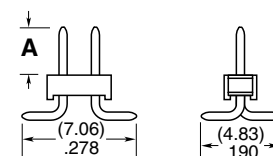
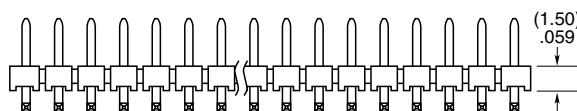

-D

-S

Note:

Some lengths, styles and options are non-standard, non-returnable.

THROUGH-HOLE LOW-PROFILE HEADER

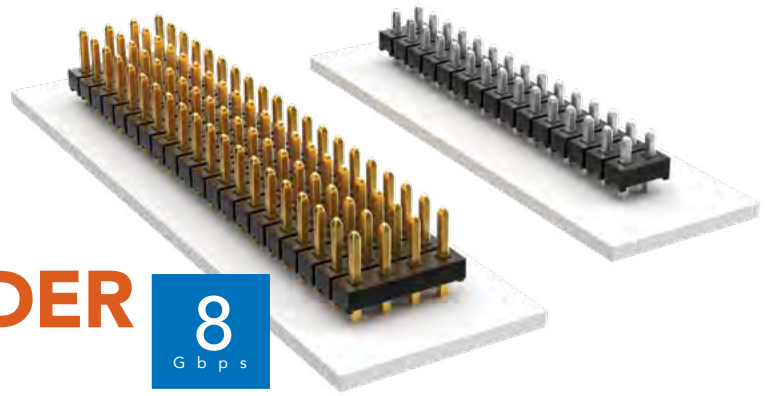

(2.00 mm) .0787" PITCH • TMM SERIES

TMM

Board Mates:
CLT, SQT, SQW, ESQT,
TLE, SMM, MMS

Cable Mates:
TCSD

SPECIFICATIONS

Insulator Material:
Black Liquid Crystal Polymer
Terminal Material:
Phosphor Bronze
Plating:
Sn or Au over
50 μ" (1.27 μm) Ni
Current Rating (SMM/TMM):
3.2 A per row
(2 pins powered)
Operating Temp Range:
-55 °C to +105 °C with Tin;
-55 °C to +125 °C with Gold
Voltage Rating:
281 VAC mated with SQW;
250 VAC mated with SQT

PROCESSING

Lead-Free Solderable:
Yes

APPLICATION

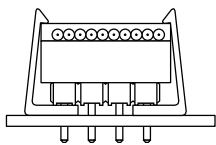

Retention Clip Option (-RC)

ALSO AVAILABLE

Other plating
(MOQ Required)



Note:
Some lengths, styles and
options are non-standard,
non-returnable.

TMM	- 1	NO. PINS PER ROW	LEAD STYLE	PLATING OPTION	ROW OPTION	OTHER OPTION
-----	-----	------------------	------------	----------------	------------	--------------

02 thru 50

Specify LEAD STYLE from chart

-F
= Gold flash on post,
Matte Tin on tail

-L
= 10 μ" (0.25 μm)
Gold on post,
Matte Tin on tail

-S
= 30 μ" (0.76 μm)
Gold on post,
Matte Tin on tail

-T
= Matte Tin

-S
= Single Row

-D
= Double Row

-Q
= Four Row

-RA & -RE
= Right-angle (Lead Style -01 only)
(2 positions minimum, -Q row)

-RC
= Retention Clip (Mates with TCSD)
(Double row only, 4 positions minimum, only available -06 lead style)

-"XXX"
= Polarized Position
(Specify position of omitted pin)

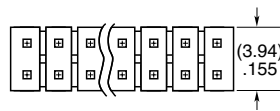
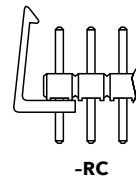
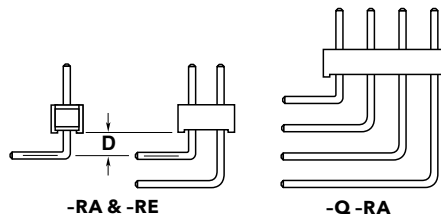
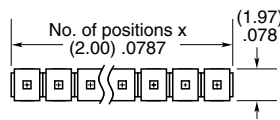

OPTION	D
-RA	(1.27) .050
-RE	(3.56) .140

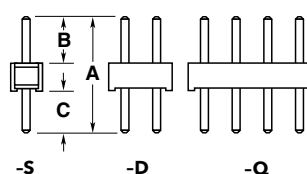
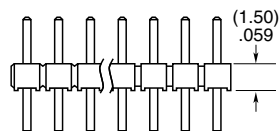
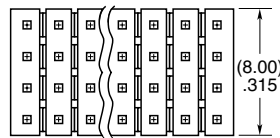

LEAD STYLE	A	B	C
-01		(3.20) .126	(3.50) .138
-02	(8.20) .323	(3.70) .146	(3.00) .118
-03		(4.00) .158	(2.70) .106
-04	(5.69) .224	(1.91) .075	
-05	(5.43) .214	(1.65) .065	(2.29) .090
-06	(9.58) .377	(3.20) .126	(4.88) .192

HORIZONTAL & MODIFIED HEADERS

(2.00 mm) .0787" PITCH • MMT/MTMM SERIES

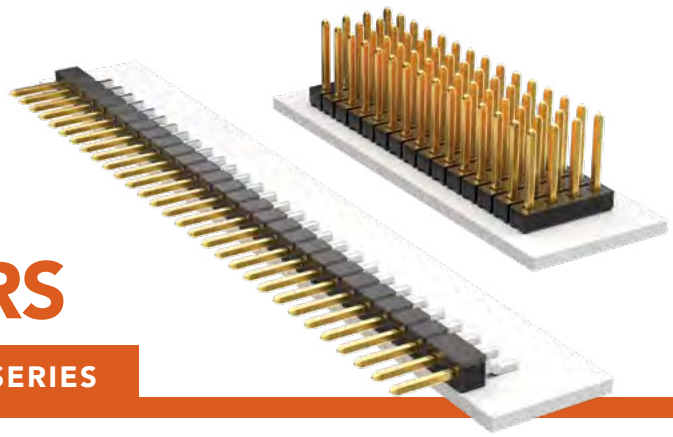

MMT/MTMM

Board Mates:

CLT, SQT, SQW, ESQT, TLE, SMM, MMS

Cable Mates:

TCSD

SPECIFICATIONS

Insulator Material:

Black Liquid Crystal Polymer

Terminal Material:

Phosphor Bronze

Plating:

Au or Sn over 50 μ" (1.27 μm) Ni

Operating Temp Range:

-55 °C to +105 °C with Tin;
-55 °C to +125 °C with Gold

PROCESSING

Lead-Free Solderable:

Yes

SMT Lead Coplanarity (MMT):

(0.10 mm) .004" max (02-25)
(0.15 mm) .006" max (26-36)*
*(.004" stencil solution may be available; contact IPG@samtec.com)

MMT	1	NO. PINS PER ROW	LEAD STYLE	PLATING OPTION	ROW OPTION	OPTION
		02 thru 36	-01 = (3.20 mm) .126" post -02 = (4.45 mm) .175" post	-F = Gold flash on post, Matte Tin on tail -L = 10 μ" (0.25 μm) Gold post, Matte Tin on tail -T = Matte Tin	-SH = Single Row -DH = Double Row -MT = Double Row Mixed Technology	-K = (4.00 mm) .157" DIA Polyimide Film Pick & Place Pad (3 positions min.) -P = Pick & Place Pad (2 positions min.) -"XXX" = Polarized Position Specify position of omitted pin -TR = Tape & Reel -FR = Full Reel Tape & Reel (must order max. quantity per reel; contact Samtec for quantity breaks)

ALSO AVAILABLE
MOQ Required

- Alignment pins
- Locking clips
- Molded pick & place pads
- Other platings

MTMM	1	NO. PINS PER ROW	LEAD STYLE	PLATING OPTION	ROW OPTION	POST HEIGHT	OPTION
		01 thru 50	Specify LEAD STYLE from chart	-F = Gold flash on post, Matte Tin on tail -L = 10 μ" (0.25 μm) Gold post, Matte Tin on tail -T = Matte Tin	-S = Single Row -D = Double Row -Q = Quad Row	-"XXX" = Post Height in inches (0.13 mm) .005" increments Example: -070 = (1.78 mm) .070"	-"XXX" = Polarized Position Specify position of omitted pin

ALSO AVAILABLE

Other Platings (MOQ Required)

LEAD STYLE	OAL
-02	(6.48) .255
-03	(7.67) .302
-04	(8.20) .323
-05	(9.58) .377
-06	(10.08) .397
-07	(11.58) .456
-08	(12.09) .476
-09	(13.59) .535
-10	(14.10) .555
-11	(15.09) .594
-12	(15.60) .614
-13	(17.09) .673
-14	(19.08) .751
-15	(21.08) .830

Note:

Some lengths, styles and options are non-standard, non-returnable.

FLEXIBLE SMT HEADER

(2.00 mm) .0787" PITCH • TMMH SERIES

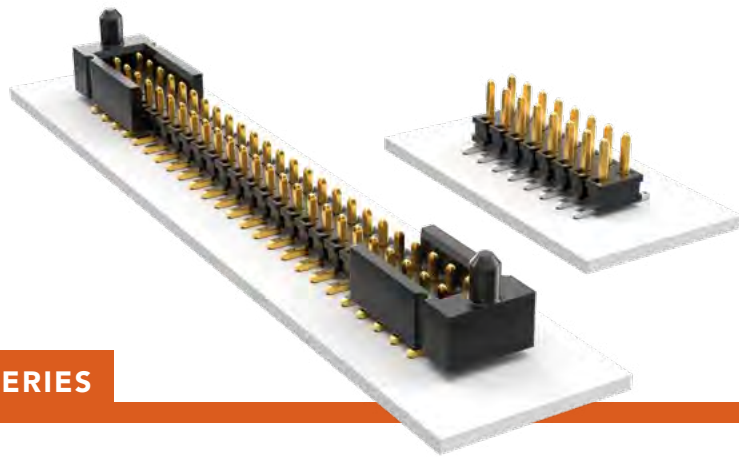

TMMH

Board Mates:

CLT, SQT, SQW, ESQT, TLE, SMM, MMS

Cable Mates:

TCSD

SPECIFICATIONS

Insulator Material:

Black Liquid Crystal Polymer

Terminal Material:

Phosphor Bronze

Plating:

Sn or Au over 50 μm (1.27 μm) Ni

Current Rating (TMMH/ESQT):

4.5 A per pin

(2 pins powered)

Current Rating (TMMH/SQT):

5.1 A per pin

(2 pins powered)

Operating Temp Range:

-55 °C to +105 °C with Tin;

-55 °C to +125 °C with Gold

Voltage Rating:

281 VAC mated with SQW;

250 VAC mated with SQT

PROCESSING

Lead-Free Solderable:

Yes

SMT Lead Coplanarity:

(0.10 mm) .004" max

TMMH	1	NO. PINS PER ROW	LEAD STYLE	PLATING OPTION	DV	FLEX SHROUD OPTIONS	OTHER OPTIONS
------	---	------------------	------------	----------------	----	---------------------	---------------

03
thru
50

Specify
LEAD
STYLE
from
chart

-F
= Gold flash
on post,
Matte Tin
on tail

-L
= 10 μm
(0.25 μm)
Gold on
post,
Matte Tin
on tail

-T
= Matte Tin

All Flex Shroud options
require 9 pins/row minimum
(For board-to-board
interfaces. Will not
mate with TCSD)

-ES
= End Shroud
(For best cost also
see TSH Series)

-EC
= End Shroud
with Locking Clip
(For best cost also
see TSH Series)
(Manual placement
required)

-EP
= End Shroud
with Guide Post

-EL
= End Shroud
with Board Lock
(Boards are positively
locked and cannot be
unmated)

-EBC
= End Shroud
with Board Lock
and Locking Clip
(Boards are positively
locked and cannot
be unmated)

-EPC
= End Shroud
with Guide Post
and Locking Clip
(Manual placement
required)

-"XXX"
= Polarized Position.
Specify position of
omitted pin

-A
= Alignment Pin
(3 positions minimum)
(Not available with -LC)

-LC
= Locking Clip
(5 positions minimum)
(Not available with -A)
(Manual placement
required)

-M
= Pick & Place Pad
(5 positions minimum)

-TR
= Tape & Reel Packaging
(36 positions maximum)
(Flex Shroud options
not available except
-ES, -EP & -EL)

-FR
= Full Reel
Tape & Reel
(must order max.
quantity per reel;
contact Samtec for
quantity breaks)
(36 positions maximum)
(Flex Shroud options
not available except
-ES, -EP & -EL)

OPTION	Z
-ES	(2.92) .115
-EC	(4.70) .185
-EP & -EPC	(6.10) .240
-EL & -EBC	(4.45) .175

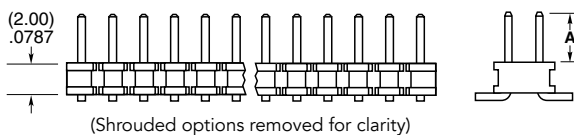
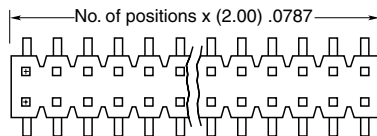
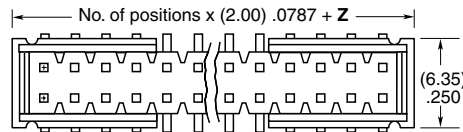

LEAD STYLE	A	MATES WITH
-01	(3.20) .126	SQT, SQW, ESQT, TLE, SMM, MMS, TCSD
-04	(1.91) .075	CLT
-05	(1.65) .065	

ALSO AVAILABLE

Other Platings
(MOQ Required)

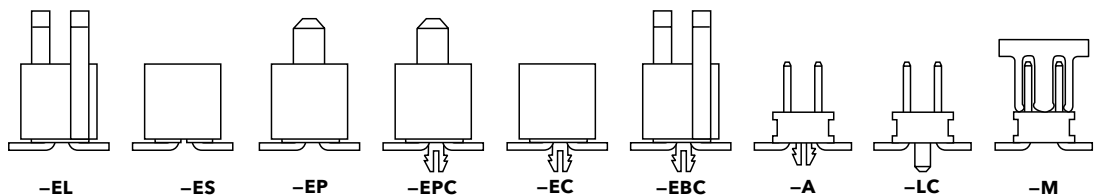

Note:

Some lengths, styles and
options are non-standard,
non-returnable.



FLEXIBLE THROUGH-HOLE HEADER

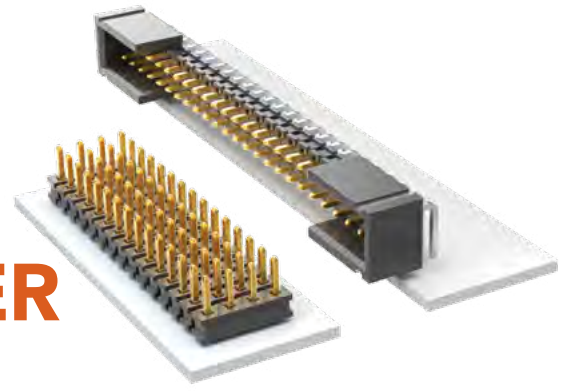

(2.00 mm) .0787" PITCH • TMMH SERIES

TMMH
Board Mates:
 CLT, SQT, SQW, ESQT, TLE, SMM, MMS

Cable Mates:
 TCSD

SPECIFICATIONS

Insulator Material:
 Black Liquid Crystal Polymer
Terminal Material:
 Phosphor Bronze
Plating:
 Sn or Au over 50 μ" (1.27 μm) Ni
Current Rating (TMMH/ESQT):
 4.5 A per pin
 (2 pins powered)
Current Rating (TMMH/SQT):
 5.1 A per pin
 (2 pins powered)
Operating Temp Range:
 -55 °C to +105 °C with Tin;
 -55 °C to +125 °C with Gold
Voltage Rating:
 281 VAC mated with SQW;
 250 VAC mated with SQT

PROCESSING

Lead-Free Solderable:
 Yes

APPLICATION

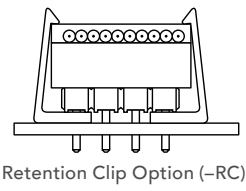

ALSO AVAILABLE

Other Platings
 (MOQ Required)



Note:
 Some lengths, styles and options are non-standard, non-returnable.

TMMH	1	NO. PINS PER ROW	LEAD STYLE	PLATING OPTION	ROW OPTION	TAIL OPTION	FLEX SHROUD OPTIONS	OTHER OPTIONS
------	---	------------------	------------	----------------	------------	-------------	---------------------	---------------

03 thru 50

Specify LEAD STYLE from chart

-F
 = Gold flash on post, Matte Tin on tail

-L
 = 10 μ" (0.25 μm) Gold on post, Matte Tin on tail

-T
 = Matte Tin

-D
 = Double Row (Required for Flex Shroud option)

-T
 = Triple Row

-Q
 = Four Row

-5
 = Five Row

-6
 = Six Row

-RA
 = Right-angle (Double & Triple Row only) (-ES, -EP, -EL Double Row only) (-EC, -EBC and -EPC not available) (-06 Lead style not available)

Flex Shroud requires -D row & 9 pins/row minimum (For board-to-board interfaces. Will not mate with TCSD)

-ES
 = End Shroud

-EC
 = End Shroud with Locking Clip (Manual placement required)

-EP
 = End Shroud with Guide Post

-EL
 = End Shroud with Board Lock (Boards are positively locked and cannot be unmated)

-EBC
 = End Shroud with Board Lock and Locking Clip (Boards are positively locked and cannot be unmated)

-EPC
 = End Shroud with Guide Post and Locking Clip (Manual placement required)

-"XXX"
 = Polarized Position (Specify position of omitted pin)

-RC
 = Retention Clip (Mates to TCSD) (Double row only, minimum position 4 and available only -06 lead style)

OPTION	Z
-ES	(2.92) .115
-EC	(4.70) .185
-EP & -EPC	(6.10) .240
-EL & -EBC	(4.45) .175

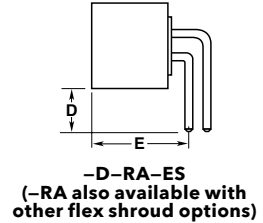
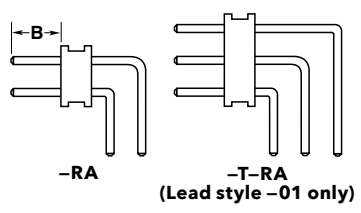
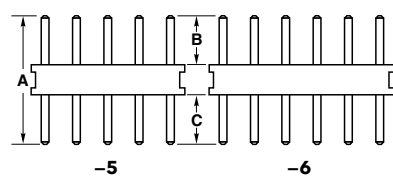
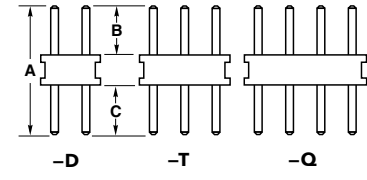
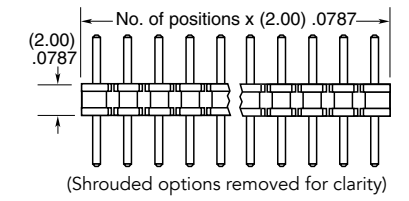
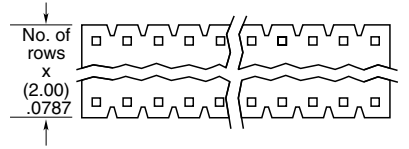
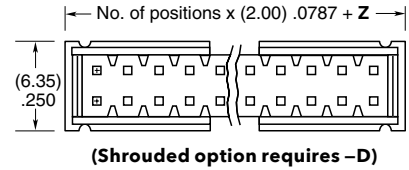

LEAD STYLE	A	B	C	D	E	F	G
-01	(7.67) .302	(3.20) .126	(2.46) .097	(2.34) .092	(6.60) .260	(5.84) .230	(4.45) .175
-04	(6.45) .254	(1.91) .075	(2.57) .101	(2.62) .103	(5.26) .207	(4.50) .177	(3.02) .119
-05	(6.45) .254	(1.65) .065	(2.29) .090	(3.12) .123	(5.26) .207		
-06	(8.74) .344	(3.20) .126	(3.53) .139	N/A	N/A	N/A	N/A

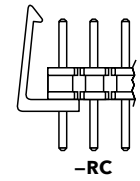
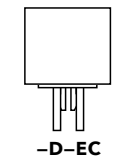
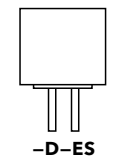
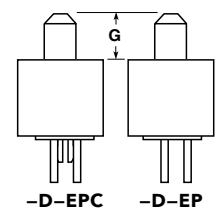
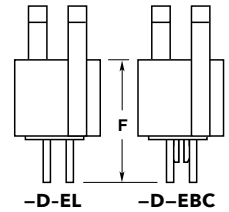

FLEX STACK

SHROUDED HEADER & STACKER

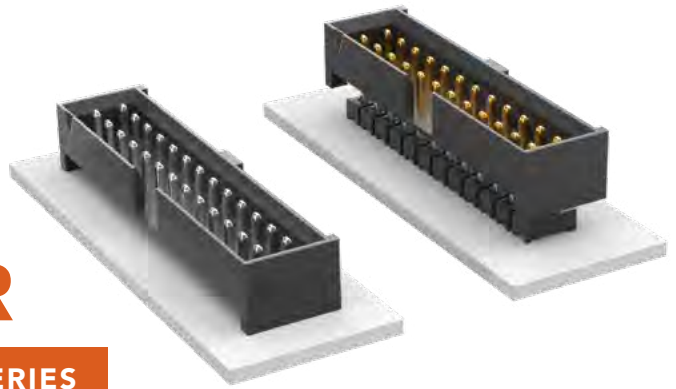

(2.00 mm) .0787" PITCH • LTMM/ZLTTM SERIES

LTMM/ZLTTM

Mates:

SQT, SQW, ESQT, SMM

SPECIFICATIONS

Insulator Material:

Black Liquid Crystal Polymer

Terminal Material:

Phosphor Bronze

Plating:

Sn or Au over
50 μ" (1.27 μm) Ni

Operating Temp Range:

-55 °C to +105 °C with Tin;
-55 °C to +125 °C with Gold

PROCESSING

Lead-Free Solderable:

Yes

SMT Lead Coplanarity:

(0.10 mm) .004" max

LTMM	1	NO. PINS PER ROW	PLATING OPTION	D	TAIL OPTION	OTHER OPTION
		04, 05, 06, 07, 08, 10, 12, 13, 15, 17, 20, 22, 25 (Standard sizes)	-F = Gold flash on post, Matte Tin on tail -L = 10 μ" (0.25 μm) Gold on post, Matte Tin on tail -T = Matte Tin		Leave blank for Through-hole -RA = Right-angle -SM = Surface Mount	-“XX” = Polarized Position -LC = Locking Clip (-SM only) (Manual placement required) -K = (7.50 mm) .295" DIA Film Pick & Place Pad (-SM only) -TR = Tape & Reel (-SM only) -FR = Full Reel Tape & Reel (must order max. quantity per reel; contact Samtec for quantity breaks) (-SM only)

ALSO AVAILABLE

MOQ Required

Other sizes

Other plating

ZLTTM	1	NO. PINS PER ROW	LEAD STYLE	PLATING OPTION	D	BODY HEIGHT	OTHER OPTION
		04, 05, 06, 07, 08, 10, 12, 13, 15, 17, 20, 22, 25 (Standard sizes)	Specify LEAD STYLE from chart	-F = Gold flash on post, Matte Tin on tail -L = 10 μ" (0.25 μm) Gold on post, Matte Tin on tail -T = Matte Tin		-“XXX” = Body Height	-“XX” = Polarized Position

LEAD STYLE	B (OAL)	MAX BODY HEIGHT
-75	(9.58) 0.377	(7.42) 0.292
-62	(10.08) 0.397	(7.92) 0.312
-65	(10.49) 0.413	(8.33) 0.328
-73	(12.09) 0.476	(9.93) 0.391
-63	(14.10) 0.555	(11.94) 0.470
-66	(15.09) 0.594	(12.93) 0.509
-69	(15.60) 0.614	(13.44) 0.529
-74	(17.09) 0.673	(14.94) 0.588
-70	(17.60) 0.693	(15.44) 0.608
-71	(21.08) 0.830	(18.92) 0.745
-72	(21.62) 0.851	(19.46) 0.766

Note:

This Series is non-standard,
non-returnable.

Note:

For added mechanical stability, Samtec recommends mechanical board spacers be used in applications with gold or selective gold plated connectors. Contact ipg@samtec.com for more information.

SHROUDED HEADERS

(2.00 mm) .0787" PITCH • TSH/TMMS SERIES



TSH

Mates:

CLT, SQT, SQW, ESQT,
TLE, SMM, MMS, PTF

TMMS

Mates:

SQT, SQW, ESQT

TSH	-	1	NO. PINS PER ROW	-	01	PLATING OPTION	-	ROW OPTION	-	OTHER OPTION
-----	---	---	------------------	---	----	----------------	---	------------	---	--------------

05, 10, 15, 20, 25,
30, 35, 40, 45
(40 & 45 = -D & -RA only)
(Standard sizes)

-F
= Gold flash on post, Matte Tin on tail

-D
= Vertical Through-hole

-LC
= Locking Clip (-DV only)
(Not available with -A)
(Manual placement required)

-L
= 10 μ" (0.25 μm) Gold on post, Matte Tin on tail

-DV
= Vertical Surface Mount

-A
= Alignment Pin (-DV only)
(Not available with -LC)

-RA
= Right-angle Through-hole

-SL
= Solder Locks (-DH only)

-T
= Matte Tin

-DH
= Horizontal Surface Mount

-K
= (4.50 mm) .177" DIA Polyimide Film Pick & Place Pad (-DH only)
(Not available with 15 - 30 positions)

-TR
= Tape & Reel

-FR
= Full Reel Tape & Reel (must order max. quantity per reel; contact Samtec for quantity breaks)

SPECIFICATIONS

Insulator Material:

Black Liquid Crystal Polymer

Terminal Material:

Phosphor Bronze

Plating:

Sn or Au over 50 μ" (1.27 μm) Ni

Operating Temp Range:

-55 °C to +105 °C with Tin;
-55 °C to +125 °C with Gold

PROCESSING

Lead-Free Solderable:

Yes

SMT Lead Coplanarity (TSH):

(0.15 mm) .006" max*
*(.004" stencil solution may be available; contact IPG@samtec.com)

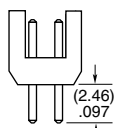
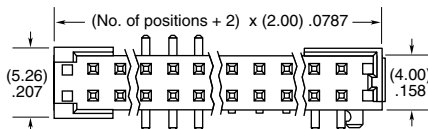

-D

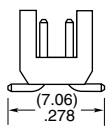

-DV

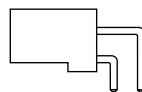

-RA

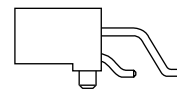

-DH

TMMS	-	1	NO. PINS PER ROW	-	01	PLATING OPTION	-	Q	-	OPTION	-	FS
------	---	---	------------------	---	----	----------------	---	---	---	--------	---	----

05, 10, 15,
20, 30, 40, 50

-F
= Gold flash on post, Matte Tin on tail

-RA
= Right-angle

-L
= 10 μ" (0.25 μm) Gold on post, Matte Tin on tail

ALSO AVAILABLE

MOQ Required

Other sizes

Other plating

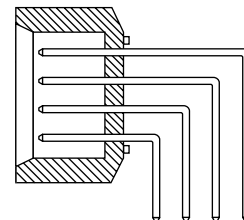
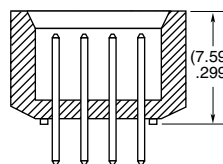
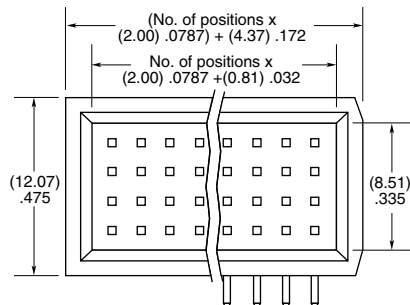

-RA

Note:

Some lengths, styles and options are non-standard, non-returnable.

SMT & THROUGH-HOLE BOARD STACKERS

(2.00 mm) .0787" PITCH • TW SERIES

CLT or MMS	SQT
8	4
G b p s	G b p s

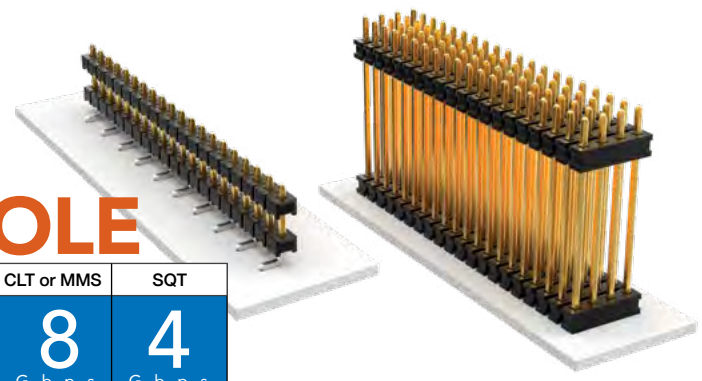

TW
Board Mates:
 CLT, SQT, SQW, ESQT,
 TLE, SMM, MMS

Cable Mates:
 TCS D

SPECIFICATIONS

Insulator Material:
 Black Liquid Crystal Polymer
Terminal Material:
 Phosphor Bronze
Plating:
 Sn or Au over
 50 μ" (1.27 μm) Ni
Current Rating:
 TW-SM = 4.9 A per pin
 (2 pins powered)
 TW-TH = 5.2 A per pin
 (2 pins powered)
Operating Temp Range:
 -55 °C to +105 °C with Tin;
 -55 °C to +125 °C with Gold

PROCESSING

Lead-Free Solderable:
 Yes
SMT Lead Coplanarity:
 (0.15 mm) .006" max*
 *(.004" stencil solution
 may be available; contact
 IPG@samtec.com)

ALSO AVAILABLE

MOQ Required

Other Platings
 End shrouds with or
 without guide post

Notes:
 For added mechanical
 stability, Samtec
 recommends
 mechanical board spacers be
 used in applications with gold or
 selective gold plated connectors.
 Contact ipg@samtec.com for
 more information.

This Series is non-standard,
 non-returnable.

TW	NO. PINS PER ROW	LEAD STYLE	PLATING OPTION	ROW OPTION	STACKER HEIGHT	SM	OTHER OPTION
----	------------------	------------	----------------	------------	----------------	----	--------------

02
thru
36

Specify
LEAD
STYLE
from
chart

-F
= Gold flash
on post,
Matte Tin
on tail

-S
= Single
Row

-D
= Double
Row

-"XXX"
= Stacker
Height
in inches
(0.13 mm)
.005"
increments

Example:
-250
= (6.35
mm) .250"

-"XXX"
= Polarized Position

-A
= Alignment Pin
(Metal or plastic
at Samtec discretion)
(4.83 mm) .190" min.
board space
(-D only)

-P
= Pick & Place Pad
(1.91 mm) .075" min.
post height
(04-36 only)

-"X"R
Specify "T" for
Tape & Reel
Specify "F" for
Full Reel Tape & Reel
(must order max.
quantity per reel;
contact Samtec for
quantity breaks)
(-07 lead style N/A)
(-06 lead style with
-P option N/A
as standard)

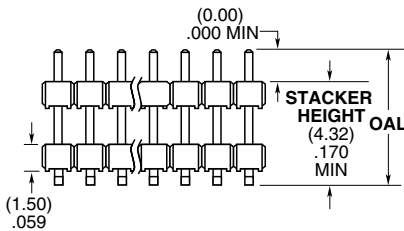
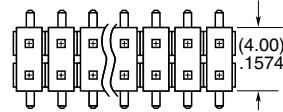
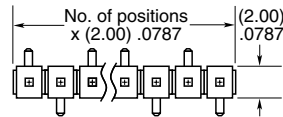

LEAD STYLE	A
-02	(7.85) .309
-03	(11.86) .467
-04	(12.37) .487
-06	(15.37) .605
-07	(17.35) .683
-09	(9.86) .388

ROW OPTION	A
-S	(5.08) .200
-D	(6.35) .250

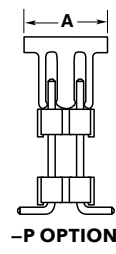
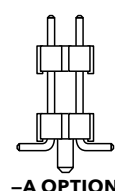

TW	NO. PINS PER ROW	LEAD STYLE	PLATING OPTION	ROW OPTION	STACKER HEIGHT	TAIL SPEC
----	------------------	------------	----------------	------------	----------------	-----------

02 thru 50

Specify
LEAD
STYLE
from
chart

-F
= Gold flash
on post,
Matte Tin
on tail

-L
= 10 μ" (0.25 μm)
Gold on
post,
Matte Tin
on tail

-T
= Matte Tin

-S
= Single Row

-D
= Double Row

-T
= Triple Row

-Q
= Four Row

-5
= Five Row

-6
= Six Row

-"XXX"
= Stacker Height
in inches
(0.13 mm) .005"
increments

Example: -250
= (6.35 mm)
.250"

-"XXX"
= Tail Length
in inches
(0.13 mm) .005"
increments

Example: -150
= (3.81 mm)
.150"

-"XXX"
= Polarized
Position
(Specify
position to
be removed)

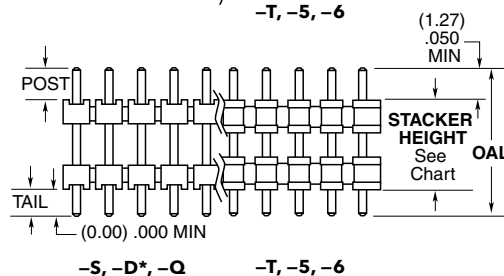
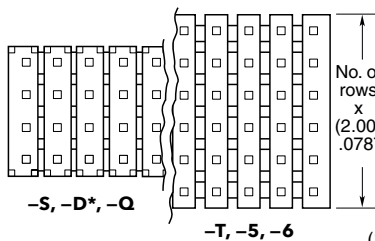

ROW OPTION	STACKER HEIGHT
-S, -D*, -Q	(3.05) .120 MIN
-T, -5, -6	(4.06) .160 MIN

*-D with stacker height
greater than (4.06 mm) .160"
will not have standoffs.

LEAD STYLE	OAL
-01	(8.20) .323
-02	(9.60) .377
-03	(13.60) .535
-04	(14.10) .555
-05	(15.10) .594
-06	(17.10) .673
-07	(19.10) .751
-08*	(21.10) .830
-09	(11.60) .456
-10	(15.60) .614
-11	(10.08) .397
-12*	(28.19) 1.110

*Style -08 & -12 = S & D only

PRESS-FIT HEADERS & SOCKETS

(2.00 mm) .0787" PITCH • PTT/PTF SERIES

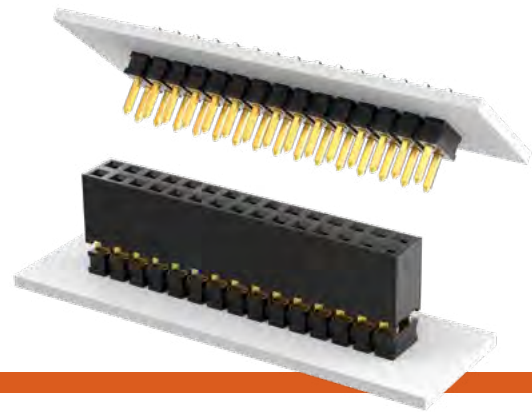

PTT
Mates:
PTF, ESQT, PTHF,
SQW, SQT, SMM

PTF
Mates:
PTT, TMMH, TMM, MTMM,
MMT, TW, LTMM, ZLTMM

SPECIFICATIONS

Insulator Material:
Black Liquid Crystal Polymer
Contact Material:
Phosphor Bronze
Plating:
Au or Sn over
50 μ " (1.27 μ m) Ni
Current Rating:
2.9 A per pin
(2 pins powered)
Operating Temp Range:
-55 °C to +125 °C
Insertion Depth:
(2.67 mm) .105" to
(3.56 mm) .140"
Normal Force:
60 grams (0.59 N) average
Max Cycles:
100 with 30 μ " (0.76 μ m) Au



02 thru 50

-L
= 10 μ " (0.25 μ m)
Gold contact,
Matte Tin on tail

-S
= Single Row
-D
= Double Row

-"XXX"
= Polarized
Position

ROW OPTION	A
-S	(2.00) .079
-D	(4.00) .158
-T	(6.00) .236
-Q	(8.00) .314
-5	(10.00) .393
-6	(12.00) .472

-T
= Triple Row
-Q
= Four Row
-5
= Five Row
-6
= Six Row

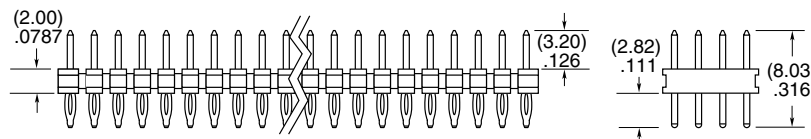
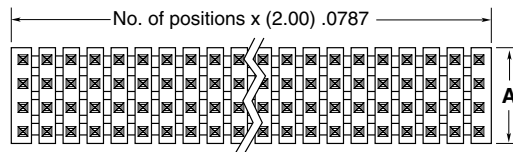

ALSO AVAILABLE

Other Platings
(MOQ Required)



02 thru 50

Specify
LEAD
STYLE
from
chart

-L
= 10 μ " (0.25 μ m)
Gold on post,
Matte Tin on tail

-"XXX"
= Polarized
Position

TOOLING

Press-Fit
PHT: CAT-PT-PH-1XX-X-X
PHF: CAT-PT-PH-1XX-X-B
For more information,
visit www.samtec.com/tooling

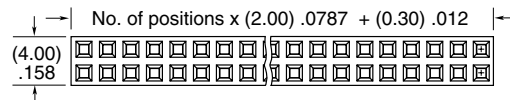

LEAD STYLE	A
-01	(6.35) .250
-03	(9.14) .360

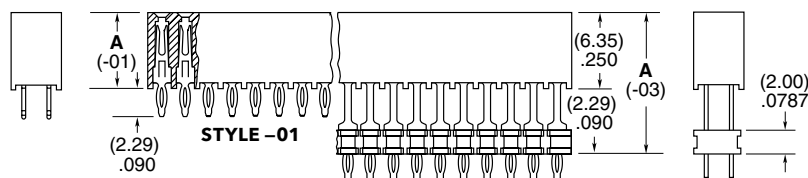

STYLE -01
STYLE -03

Note:
Some lengths, styles and
options are non-standard,
non-returnable.

FLEXIBLE ELEVATED & SELF-NESTING SOCKETS

(2.00 mm) .0787" PITCH • ESQT/ESQT (-368)/PTHF SERIES

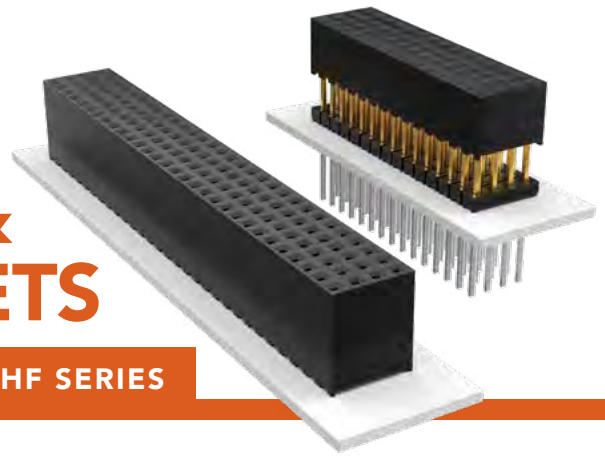

ESQT

Board Mates:
TMMH, TMM, MTMM,
MMT, TW, LTMM, ZLTMM,
ESQT, PTT, TSH, TMMS

Cable Mates:
TCMD

SPECIFICATIONS

Insulator Material:
Black Liquid Crystal Polymer
Contact Material:
Phosphor Bronze
Plating:
Sn or Au over
50 μ" (1.27 μm) Ni
Current Rating (ESQT/TMMH):
4.5 A per pin
(2 pins powered)
Operating Temp Range:
-55 °C to +125 °C
Insertion Depth:
(2.62 mm) .103" to
(5.03 mm) .198" with
(0.38 mm) .015" wipe
Max Cycles:
100 with 10 μ" (0.25 μm) Au
Lead-Free Solderable:
Yes, for -S, -D & -Q
(Wave only for -T, -5 & -6)

ESQT	1	NO. PINS PER ROW	LEAD STYLE	PLATING OPTION	ROW OPTION	BODY HEIGHT	OTHER OPTION
		02 thru 50	Specify LEAD STYLE from chart	-F = Gold flash on contact, Matte Tin on tail -L = 10 μ" (0.25 μm) Gold on contact, Matte Tin on tail -M = 20 μ" (0.51 μm) Gold on contact, Matte Tin on tail -GF = 15 μ" (0.38 μm) Gold on contact, Gold flash on tail (Recommended for self-nesting) (-02 lead style only)	-S = Single Row -D = Double Row -T = Triple Row -Q = Quad Row -5 = Five Row -6 = Six Row	"XXX" = Body Height (in inches) (7.87 mm) .310" minimum for -S, -D, -Q (9.53 mm) .375" minimum for -T, -5, -6	"XXX" = Polarized Position (Indicate position number)

LEAD STYLE	A	MAX TAIL	MAX BODY HEIGHT
-02	(21.59) .850	(13.72) .540	(20.32) .800
-03	(11.63) .458	(3.76) .148	(10.36) .408

ESQT (-368)/PTHF

Mates:
ESQT, PTHF

SPECIFICATIONS

Insulator Material:
Black Liquid Crystal Polymer (ESQT-368)
Black High Temp Nylon (PTHF)
Contact Material:
Phosphor Bronze
Plating:
Au or Sn over
50 μ" (1.27 μm) Ni
Operating Temp Range:
-55 °C to +125 °C
Normal Force:
60 grams (0.59 N) average
Max Cycles:
100 with 10 μ" (0.25 μm) Au
Lead-Free Solderable:
Yes (ESQT-368)

SERIES	1	NO. PINS PER ROW	LEAD STYLE	PLATING OPTION	Q	368
		02 thru 50	Specify LEAD STYLE from chart	-GF = 15 μ" (0.38 μm) Gold on contact, Gold flash on tail (-02 Lead Style only) -M = 20 μ" (0.51 μm) Gold on contact, Matte Tin on tail (-03 Lead Style only)		

LEAD STYLE	ESQT		PTHF	
	A	B	A	B
-02	(21.59) .850	(12.24) .482	(21.59) .850	(12.24) .482
-03	(11.63) .458	(2.29) .090	(12.34) .486	(3.00) .118

ESQT (-368) SERIES

PTHF SERIES

TOOLING

Press-Fit
CAT-PT-PT-130-A-4
For more information, visit
www.samtec.com/tooling

Note:
This Series is non-standard,
non-returnable.

COST-EFFECTIVE RUGGED SOCKETS

(2.00 mm) .0787" PITCH • SQW/SQT SERIES

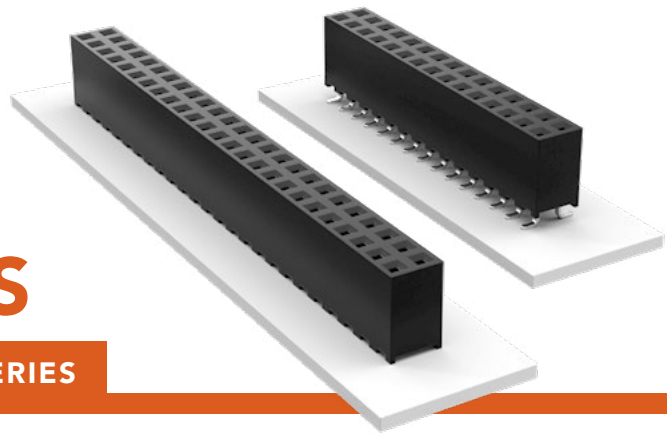

SQW/SQT

Board Mates:

TMMH, TMM5, TMM, MTMM, MMT, TW, TSH, LTMM, ZLTMM, PTT

Cable Mates:

TCMD

SPECIFICATIONS

Insulator Material:

Black Liquid Crystal Polymer

Contact Material:

Phosphor Bronze

Plating:

Sn or Au over
50 μ" (1.27 μm) Ni

SQW Current Rating

(SQW/TMMH):
3.8 A per pin (2 pins powered)

SQT Current Rating

(TMMH/SQT):
5.1 A per pin (2 pins powered)

Voltage Rating:

281 VAC mated with TMM;

250 VAC mated with TMMH

Operating Temp Range:

-55 °C to +125 °C

SQW Insertion Depth:

(2.62 mm) .103" to

(5.03 mm) .198" with

(0.38 mm) .015" wipe

SQT Insertion Depth:

(2.62 mm) .103" to

(5.03 mm) .198"

SQT Normal Force:

60 grams (0.59 N) average

Max Cycles:

100 with 10 μ" (0.25 μm) Au

SQW	1	NO. PINS PER ROW	01	PLATING OPTION	ROW OPTION	OPTION
		02 thru 50		-F = Gold flash on contact, Matte Tin on tail	-D = Double Row	-"XXX" = Polarized Position -D-VS only options:
				-L = 10 μ" (0.25 μm) Gold on contact, Matte Tin on tail	-D-VS = Double Row Surface Mount	-A = Alignment Pin (5 positions minimum) Metal or plastic at Samtec discretion. (Not available with -LC)
					-T = Triple Row	-LC = Locking Clip (5 positions minimum) (Not available with -A) (Manual placement required)
					-Q = Four Row	-K = (4.25 mm) .167" DIA Polyimide Film Pick & Place Pad (4 positions minimum)
					-5 = Five Row	-P = Pick & Place Pad (4 positions minimum)
					-6 = Six Row	-TR = Tape & Reel (4-28 positions only)
						-FR = Full Reel Tape & Reel (must order max. quantity per reel; contact Samtec for quantity breaks) (4-28 positions only)

PROCESSING

SQW Lead-Free Solderable:

Yes, for -D & -D-VS

(Wave only for -T, -Q, -5 & -6)

SQT Lead-Free Solderable:

Yes

SMT LeadCoplanarity:

(0.10 mm) .004" max (02-10)

(0.15 mm) .006" max (11-50)*

*(.004" stencil solution may be available; contact

IPG@samtec.com)

SQT	1	NO. PINS PER ROW	LEAD STYLE	PLATING OPTION	ROW OPTION	OTHER OPTION
		02 thru 50	Specify LEAD STYLE from chart	-F = Gold flash on contact, Matte Tin on tail	-S = Single Row	-RA = Right-angle (-Q, -5 & -6 Row not available) (Lead Style -01 only)
				-L = 10 μ" (0.25 μm) Gold on contact, Matte Tin on tail	-D = Double Row	-"XXX" = Polarized Position (Indicate position number)
					-T = Triple Row	
					-Q = Four Row	
					-5 = Five Row	
					-6 = Six Row	

LEAD STYLE	A
-01	(2.29) .090
-02	(15.24) .600
-03	(5.28) .208

-RA OPTION
(-Q, -5 & -6 not available)

Note:

Some lengths, styles and options are non-standard, non-returnable.

TIGER CLAW™ SOCKET STRIP

(2.00 mm) .0787" PITCH • MMS SERIES

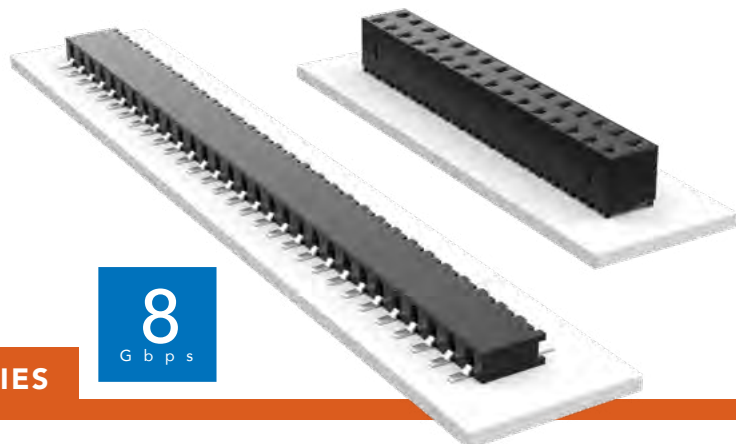

MMS

Board Mates:
TMMH, TMM, MTMM, MMT,
TW, LTMM, ZLTMM, TSH

Cable Mates:
TCMD

SPECIFICATIONS

Insulator Material:

Black LCP

Contact Material:

Phosphor Bronze

Plating:

Sn or Au over

50 μm (1.27 μm) Ni

Current Rating (MMS/TMM):

3.9 A per pin

(2 pins powered)

Operating Temp Range:

-55 °C to +125 °C with Gold

-55 °C to +105 °C with Tin

Insertion Depth:

DH = (2.13 mm) .084" to

(2.79 mm) .110",

SH = (2.13 mm) .084"

minimum or pass-through

Top Entry DV/SV =

(2.13 mm) .084" to

(4.32 mm) .170"

Bottom Entry DV/SV =

(4.27 mm) .168" minimum

(Plus board)



02 thru 40

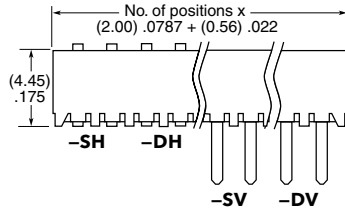
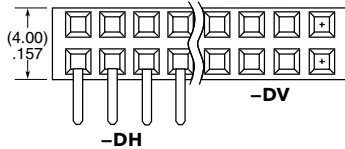
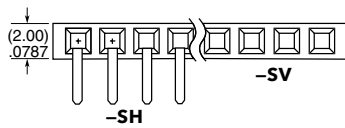

-F
= Gold flash on contact,
Matte Tin on tail

-L
= 10 μm (0.25 μm)
Gold contact,
Matte Tin on tail

-SV
= Single
Vertical

-SH
= Single
Horizontal

-DV
= Double
Vertical

-DH
= Double
Horizontal

-“XX”
= Polarized
Position

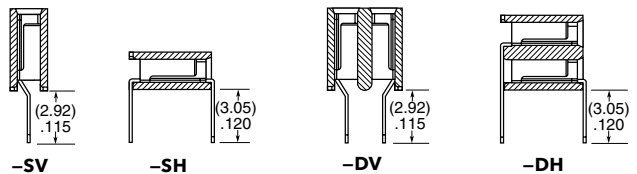

PROCESSING

Lead-Free Solderable:

Yes

SMT Lead Coplanarity:

(0.15 mm) .006" max*

*(.004" stencil solution
may be available; contact
IPG@samtec.com)



02 thru 40

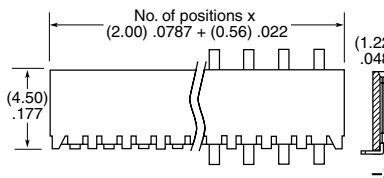
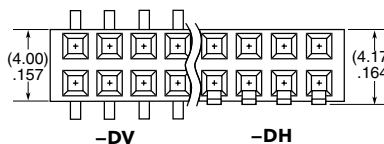
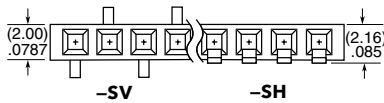

-F
= Gold flash
on contact,
Matte Tin on tail

-L
= 10 μm (0.25 μm)
Gold contact,
Matte Tin on tail

-SV
= Single
Vertical

-SH
= Single
Horizontal

-DV
= Double
Vertical

-DH
= Double
Horizontal

-“XX”
= Polarized Position

-K
= (5.50 mm) .217" DIA
Polyimide Film
Pick & Place Pad
(-SV & -DV only)
(-SV = 3 positions min.)
(-DV = 4 positions min.)

-M
= Metal Pick & Place Pad
(4 positions min.)
(-DV only)

-P
= Plastic Pick & Place Pad
(4 positions min., -SV only)
(5 positions min., -DV only)

-TR
= Tape & Reel

-FR
= Full Reel
Tape & Reel
(must order max.
quantity per reel;
contact Samtec for
quantity breaks)

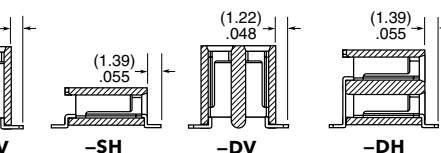
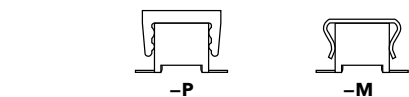

ALSO AVAILABLE

MOQ Required

Alignment Pin (-DV only)
Locking clips and Through-hole
pass-through options
Other platings

Note:

Some lengths, styles and
options are non-standard,
non-returnable.

COST-EFFECTIVE & DUAL WIPE SOCKETS

(2.00 mm) .0787" PITCH • TLE/CLT SERIES

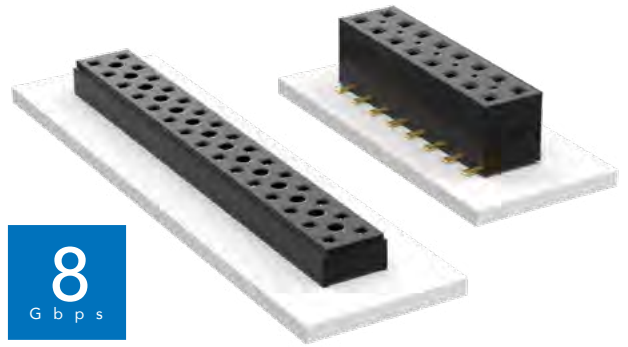

TLE

Mates:
TMMH, TMM, MTMM,
MMT, TW, LTMM, ZLTMM,
TCMD, TSH

CLT

Mates:
TMM, TMMH, MTMM,
MMT, TW, TSH

SPECIFICATIONS

TLE

Insulator Material:
Black Liquid Crystal Polymer
Contact Material:
Phosphor Bronze
Plating:
Au over 50 μ" (1.27 μm) Ni
Current Rating (TLE/TMMH):
3.2 A per pin
(2 pins powered)
Operating Temp Range:
-55 °C to +125 °C
Insertion Depth:
(2.08 mm) .082" to
(4.37 mm) .172" with
(0.38 mm) .015" wipe,
pass-through, or
(3.35 mm) .132" min
for bottom entry

CLT

Same as TLE except:
Plating:
Sn or Au over 50 μ" (1.27 μm) Ni
Current Rating (TMMH/CLT):
4.1 A per pin
(2 pins powered)
Insertion Depth:
Top Entry=
(1.40 mm) .055" minimum
Bottom Entry=
(2.57 mm) .101" minimum
(add board thickness for
correct post OAL)
Max Cycles:
100 with 10 μ" (0.25 μm) Au

PROCESSING

TLE

Lead-Free Solderable:
Yes
SMT Lead Coplanarity:
(0.10 mm) .004" max (02-26)
(0.15 mm) .006" max (27-50)*
*(.004" stencil solution
may be available; contact
IPG@samtec.com)

CLT

Same as TLE except:
SMT Lead Coplanarity:
(0.10 mm) .004" max (02-25)
(0.15 mm) .006" max (26-34)*
(0.20 mm) .008" max (35-50)*
*(.004" stencil solution
may be available; contact
IPG@samtec.com)

Note:
Some lengths, styles and
options are non-standard,
non-returnable.

TLE	- 1	NO. PINS PER ROW	- 01	PLATING OPTION	- DV	OPTION
TIGER BEAM CONTACT		02 thru 50		-G = 10 μ" (0.25 μm) Gold		-A = Alignment Pin (3 positions minimum) -K = (5.00 mm) .197" DIA Polyimide Film Pick & Place Pad (3 positions minimum) -P = Metal Pick & Place Pad (4 positions minimum) -TR = Tape & Reel Packaging (2-37 positions only) -FR = Full Reel Tape & Reel (must order maximum quantity per reel; contact Samtec for quantity breaks) (2-37 positions only)

CLT	- 1	NO. PINS PER ROW	LEAD STYLE	PLATING OPTION	- D	OTHER OPTIONS
TIGER CLAW CONTACT		02 thru 50	-01 = Through-hole -02 = Surface Mount -03 = Through-hole	-F = Gold flash on contact, Matte Tin on tail -L = 10 μ" (0.25 μm) Gold on contact, Matte Tin on tail -G = 10 μ" (0.25 μm) Gold on contact, Gold flash on tail		All options require Style -02 -BE = Bottom Entry (Required for bottom entry applications) -A = Alignment Pin (3 positions minimum) Metal or plastic at Samtec's discretion -K = (5.00 mm) .197" DIA Polyimide Film Pick & Place Pad (04 thru 50 only) -P = Pick & Place Pad (4 positions minimum) (Not always necessary for auto placement.) -TR = Tape & Reel (36 positions max) -FR = Full Reel Tape & Reel (must order maximum quantity per reel; contact Samtec for quantity breaks) (36 positions max)

ALSO AVAILABLE
Other Platings
(MOQ Required)

LEAD STYLE	A
-01	(2.16) .085
-03	(2.95) .116

SELF MATING HERMAPHRODITIC STRIP

(2.00 mm) .0787" PITCH • LS2 SERIES

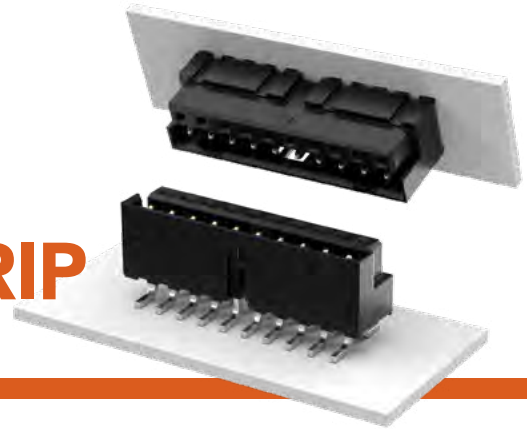

LS2
Mates:
LS2

LS2	1	NO. PINS PER ROW	LEAD STYLE	PLATING OPTION	D	TAIL OPTION	OPTION
-----	---	------------------	------------	----------------	---	-------------	--------

05, 10, 15,
20, 25, 30

-01
= Through-hole

-02
= Surface Mount

-F
= Gold flash on contact,
Matte Tin on tail

-L
= 10 μ" (0.25 μm)
Gold on contact,
Matte Tin on tail

-01 only

-RA1
= Right-angle
(Shroud Down)

-RA2
= Right-angle
(Shroud Up)

-K
= (6.30 mm)
.248" DIA
Polyimide
Film Pick &
Place Pad
(-02 only)

-TR
= Tape &
Reel

-FR
= Full Reel
Tape & Reel
(must order
max. quantity
per reel;
contact
Samtec for
quantity
breaks)

SPECIFICATIONS

Insulator Material:
Black Liquid Crystal
Polymer

Contact Material:
Phosphor Bronze

Plating:
Au or Sn over
50 μ" (1.27 μm) Ni

Current Rating:
3.2 A per pin
(6 adjacent pins powered)

Voltage Rating:
475 VAC mated with LS2

Operating Temp Range:
-55 °C to +125 °C

PROCESSING

Lead-Free Solderable:

Yes

SMT Lead Coplanarity:

(0.15 mm) .006" max*
*(.004" stencil solution
may be available; contact
IPG@samtec.com)

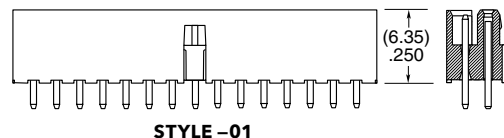
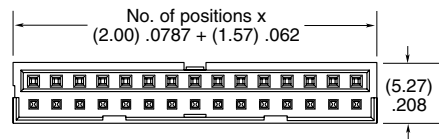
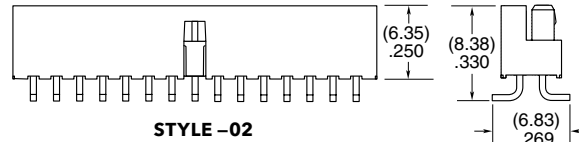
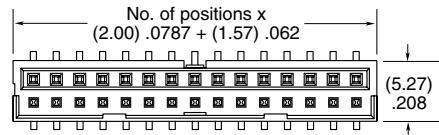

APPLICATION

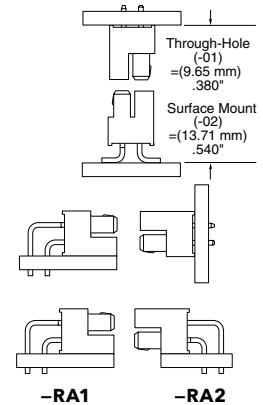

-RA1

-RA2

-RA1

-RA2

ALSO AVAILABLE

MOQ Required

Alignment pin
Other platings
Other stack heights

Note:
Some lengths, styles and
options are non-standard,
non-returnable.

PRESS-FIT HEADERS & SOCKETS

(2.54 mm) .100" PITCH • PHT/PHF SERIES



PHT

Board Mates:
SSW, SSQ, ESW,
ESQ, BCS, BSW,
CES, SLW, PHF, SSM

Cable Mates:
IDSD, IDSS

PHF

Board Mates:
TSW, MTSW, MTLW,
EW, ZW, TSS, ZSS,
TSM, TSSH, PHT, DW, HW

SPECIFICATIONS

Insulator Material:
Liquid Crystal Polymer
Contact Material:
Phosphor Bronze
Plating:
Au or Sn over
50 μm (1.27 μm) Ni
Current Rating (PHT/PHF):
4.8 A per pin
(2 pins powered)
Operating Temp Range:
-55 °C to +125 °C with Gold
(PHF) Insertion Depth:
(3.68 mm) .145" to
(6.35 mm) .250"



01
= (single row only)
02 thru 50

Specify
**LEAD
STYLE**
from
chart

-L
= 10 μm (0.25 μm)
Gold on post,
Matte Tin on tail

-S
= Single
Row
-D
= Double
Row

-“XXX”
= Polarized
Position

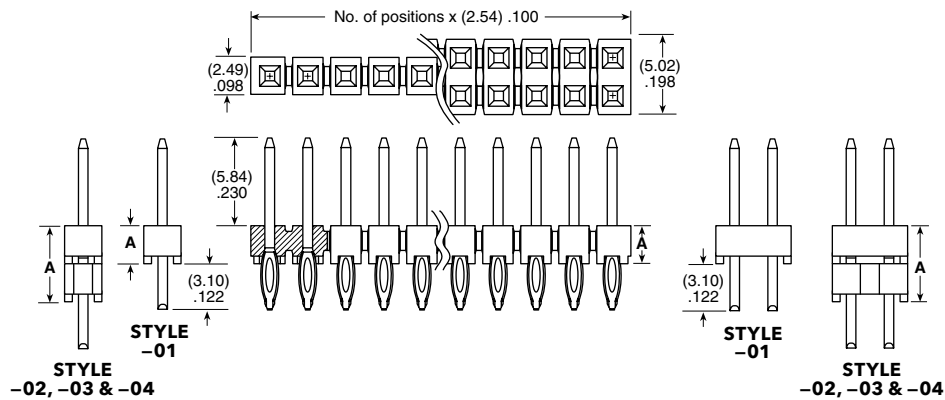

LEAD STYLE	A
-01	(2.54) .100
-02	(5.08) .200
-03	(7.62) .300
-04	(10.16) .400

PROCESSING

Contact ipg@samtec.com



01
= (single row only)
02 thru 50

Specify
**LEAD
STYLE**
from
chart

-L
= 10 μm (0.25 μm)
Gold on post,
Matte Tin on tail

-S
= Single
Row
-D
= Double
Row

-“XXX”
= Polarized
Position

ALSO AVAILABLE

Other Platings
(MOQ Required)

TOOLING

Press-Fit
PHT: CAT-PT-PH-1XX-X-X
PHF: CAT-PT-PH-1XX-X-B
For more information, visit
www.samtec.com/tooling

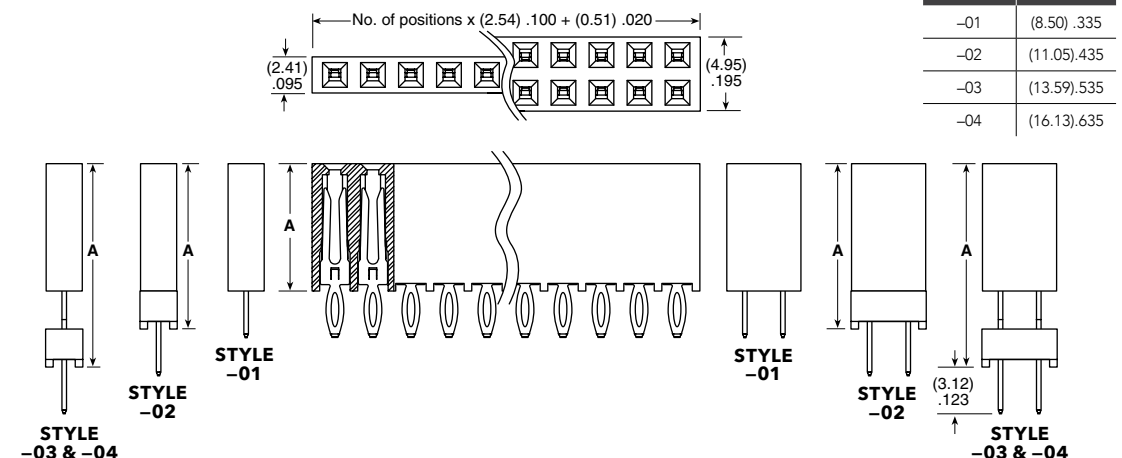

LEAD STYLE	A
-01	(8.50) .335
-02	(11.05) .435
-03	(13.59) .535
-04	(16.13) .635

Note:
Some lengths, styles and
options are non-standard,
non-returnable.

THROUGH-HOLE .025" SQ POST HEADER

(2.54 mm) .100" PITCH • TSW/HTSW SERIES

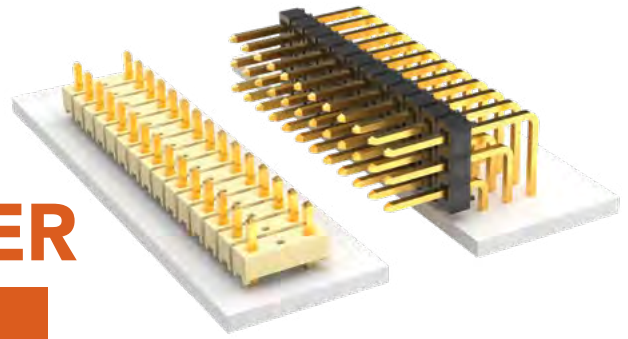

TSW/HTSW

Board Mates:

SSW, SSQ, SSM, ESW, ESQ, BCS, BSW, CES, SLW

Cable Mates:

IDSD, IDSS

SERIES	PIN CENTERS	NO. PINS PER ROW	LEAD STYLE
--------	-------------	------------------	------------

TSW
= Standard Strip

HTSW
= Hi-Temp Strip

-1
= .100" (2.54 mm) Centers,
(All positions filled)

-2
= .200" (5.08 mm) Centers,
(Every other position filled)

01 thru 50
= .100" (2.54 mm)
Center Version

02 thru 25
= .200" (5.08 mm)
Center Version

Specify
LEAD STYLE
from chart

SPECIFICATIONS

Insulator Material:

TSW: PBT

HTSW: Natural LCP

Terminal Material:

Phosphor Bronze

Plating:

Au or Sn over 50 μ" (1.27 μm) Ni

Operating Temp Range:

-55 °C to +125 °C with Gold

-55 °C to +105 °C with Tin

Voltage Rating:

550 VAC mated with SSW;

500 VAC mated with

BCS or ESQ;

450 VAC -RA/-RE mated with

BCS or SSM

400 VAC mated with CES

Lead-Free Solderable:

HTSW: Yes

TSW: No, Lead Wave Only

CURRENT RATING (PER PIN)

TSW mated with

ESW	SSW	SLW	SSQ	SSM	BCS	SNT
5.2 A	5.7 A	5.2 A	6.3 A	5.2 A	4.6 A	4.3 A

2 POSITIONS POWERED

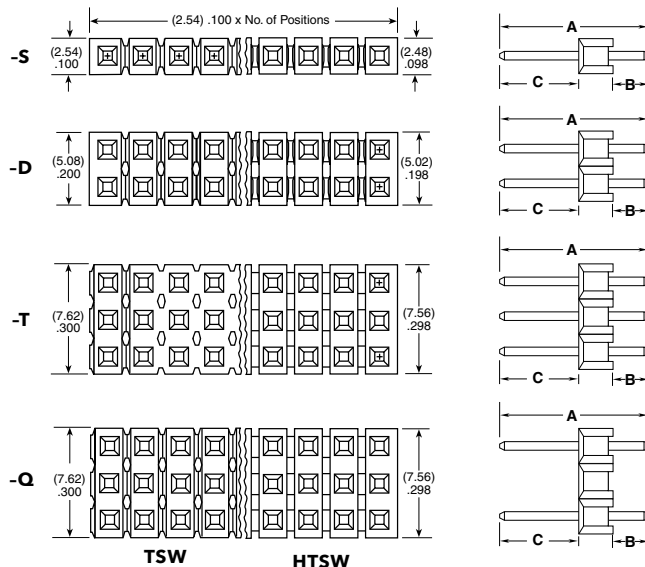

TSW

HTSW

Straight Pin Versions

ALSO AVAILABLE

Other Platings
(MOQ Required)

OTHER SOLUTIONS

Elevated Right-angle option
Shunts

LEAD STYLE	A	B	C
*-05	(8.51) .335	(3.30) .130	(2.67) .105
*-06	(7.62) .300	(2.41) .095	(2.67) .105
*-07	(10.92) .430	(2.54) .100	
*-08	(13.46) .530	(5.08) .200	
-09	(18.54) .730	(10.16) .400	
-10	(21.08) .830	(12.70) .500	(5.84) .230
-11	(23.62) .930	(15.24) .600	
-12	(26.16) 1.030	(17.78) .700	
-13	(31.24) 1.230	(22.86) .900	
-14	(13.46) .530		(8.13) .320
*-15		(2.79) .110	(13.21) .520
*-16	(18.54) .730	(7.87) .310	(8.13) .320
*-17	(21.08) .830		(15.74) .620
*-18	(23.62) .930	(2.79) .110	(18.29) .720

* Available with -LL (Locking Lead) Option
Specify -07 for best mate with IDXX Series IDC Cable

LEAD STYLE	A	B	C
*-19	(26.16) 1.030	(2.79) .110	(20.83) .820
*-20	(31.24) 1.230		(25.91) 1.020
*-21	(36.32) 1.430	(2.79) .110	(30.99) 1.220
*-22	(16.00) .630	(7.62) .300	(5.84) .230
*-23	(11.30) .445		
*-24	(12.15) .480	(2.92) .115	(6.73) .265
*-25	(16.00) .630	(5.33) .210	(8.13) .320
▲-26	(11.58) .456	(3.20) .126	
-27	(33.78) 1.330	(25.40) 1.000	(5.84) .230
-28	(28.70) 1.130	(20.32) .800	
-29	(33.78) 1.330	(23.11) .910	(8.13) .320
-30	(28.70) 1.130	(18.03) .710	
+--41	(9.27) .365	(0.89) .035	(5.84) .230
+--42	(11.94) .470	(1.27) .050	(8.13) .320

+ Style -41 & -42 available with HTSW only.
▲ Except: Style -26 (0.46) .018 DIA Tail

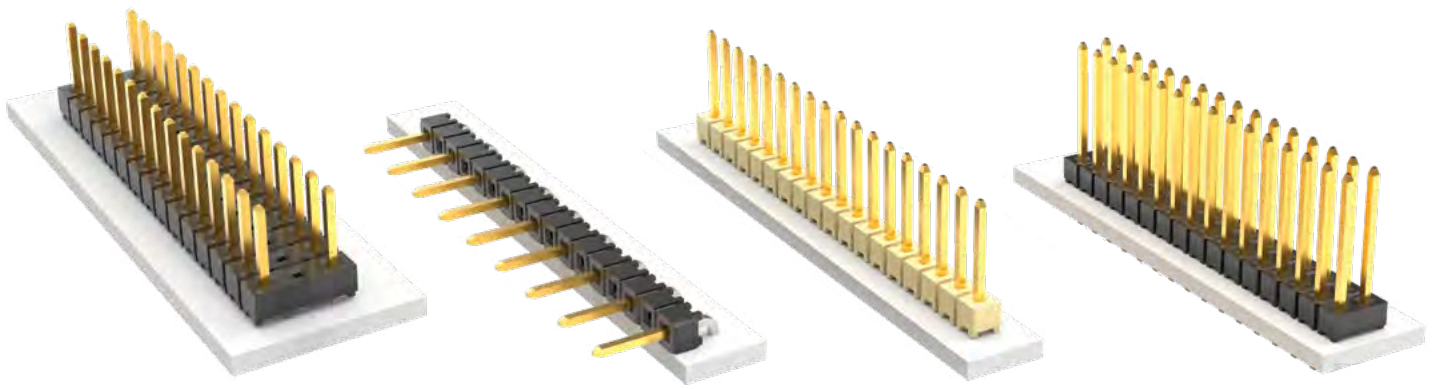

PLATING OPTION

- F**
= Gold flash on post, Matte Tin on tail
- L**
= 10 μ" (0.25 μm) Gold on post, Matte Tin on tail
- G**
= 10 μ" (0.25 μm) Gold on post, Gold flash on balance
- T**
= Matte Tin

ROW OPTION

- S**
= Single Row
- D**
= Double Row
- T**
= Triple Row
- Q**
= Double Row
(5.08 mm).200" row space

OTHER OPTION

- RA or -RE**
= Right-angle
- NA**
= Right-angle
(Using straight body for coplanar mating with SSW-RA series)
- LL**
= Locking Lead
See charts for available styles.
Not available with single row 1 or 2 positions.
Recommended hole size
(1.02 mm ± 0.03 mm) .040" ± .001
- LC**
= Locking Clip
(Styles -08 thru -13 & -22 only)
(Requires 4 pin minimum)
(Not available with T, -Q, -RA or -RE)
- LA**
= -RA Option with -LL Option
- "XXX"**
= Polarized Position

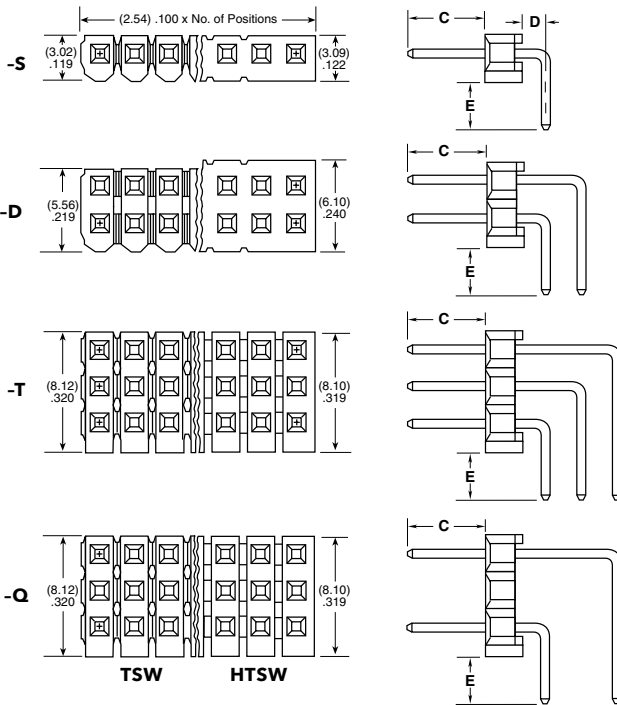

Right-Angle Versions

LEAD STYLE	D
-RA	(1.52) .060
-RE	(4.06) .160

RIGHT-ANGLE VERSIONS		
-RE LEAD STYLE	C	SINGLE E
-09	(5.84) .230	(4.83) .190
-10		(7.37) .290
-11		(9.91) .390
-12		(12.45) .490
-13		(17.53) .690
-16	(8.13) .320	(2.54) .100
-21	(5.84) .230	(22.61) .890
-22		(2.29) .090
-27		(20.07) .790
-28		(14.99) .590

-RA LEAD STYLE	RIGHT-ANGLE VERSIONS			
	SINGLE (-S)		DOUBLE (-D)	TRIPLE (-T & -Q)
	C	E	E	E
-08	(5.84) .230	(2.29) .090	(2.29) .090	(2.29) .090
-09		(7.37) .290	(7.37) .290	(7.37) .290
-10		(9.91) .390	(9.91) .390	(9.91) .390
-11		(12.45) .490	(12.45) .490	(12.45) .490
-12		(14.99) .590	(14.99) .590	(14.99) .590
-13		(20.07) .790	(20.07) .790	N/A
*-16	(8.13) .320	(5.08) .200	(5.08) .200	(5.08) .200
-21	(5.84) .230	(25.15) .990	N/A	N/A
*-22		(4.83) .190	(4.83) .190	(4.83) .190
*-25	(8.13) .320	(2.54) .100	(2.54) .100	(2.54) .100
-27	(5.84) .230	(22.61) .890	N/A	N/A
-28		(17.53) .690	(17.53) .690	
-29		(20.32) .800	N/A	
-30	(8.13) .320	(15.24) .600	(15.24) .600	

* Available with -LA (Locking Lead) Option

SURFACE MOUNT .025" SQ POST HEADER

(2.54 mm) .100" PITCH • TSM SERIES

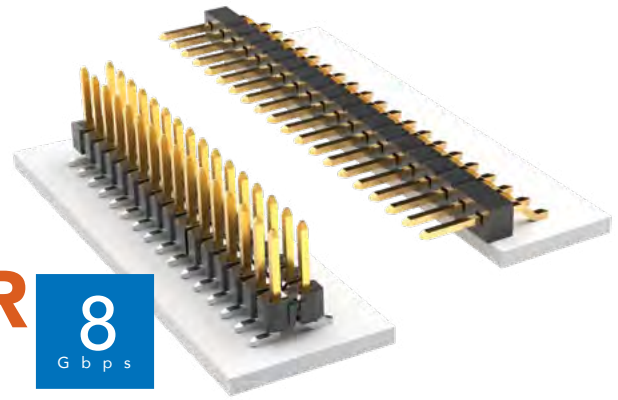

TSM

Board Mates:

SSW, SSQ, SSM, BSW, ESW,
ESQ, BCS, SLW, CES, HLE

Cable Mates:

IDSS, IDSD

TSM

1

NO. PINS PER ROW

LEAD STYLE

02 thru 36

Specify
LEAD STYLE
from chart

SPECIFICATIONS

Insulator Material:

Black Liquid Crystal Polymer

Terminal Material:

Phosphor Bronze

Plating:

Au or Sn over

50 μ" (1.27 μm) Ni

Operating Temp Range:

-55 °C to +105 °C with Tin;

-55 °C to +125 °C with Gold

Voltage Rating:

475 VAC -SV/-DV mated with

BCS or SSM

PROCESSING

Lead-Free Solderable:

Yes

-DH/-SH Lead Coplanarity:

(0.15 mm) .006" max (02-36)*

-DV/-SV Lead Coplanarity:

(0.10 mm) .004" max (02-05)

(0.13 mm) .005" max (06-10)*

(0.15 mm) .006" max (11-36)*

*(.004" stencil solution

may be available; contact

IPG@samtec.com)

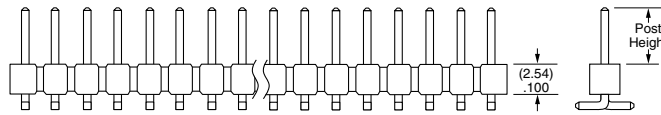
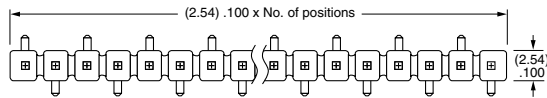

-SV Row Option

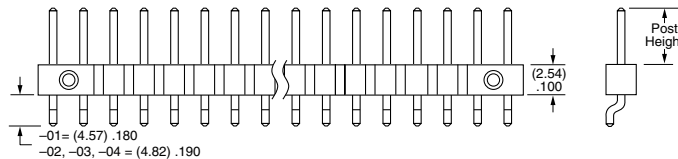
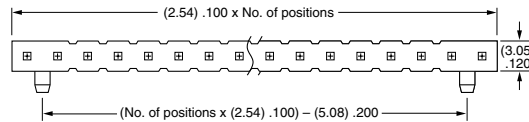

-01 = (4.57) .180
-02, -03, -04 = (4.82) .190

-SH Row Option

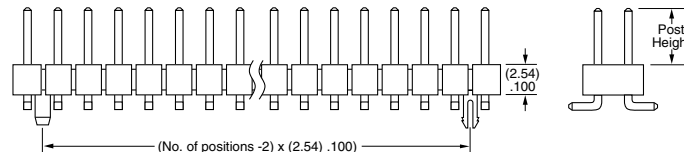
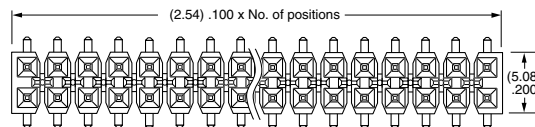

-DV Row Option

LEAD STYLE	POST HEIGHT	MATES WITH
-01	(5.84) .230	SSW, BCS, SSM, IDSS, IDSD
-02	(8.13) .320	SSM -DH
-03	(10.67) .420	Bottom Mount & Pass Through
-04	(3.05) .120	SLW, CES, HLE

MATES	CURRENT RATING (PER PIN)
TSM/SSW	4.7 A
TSM/SSM	5.4 A
TSM/HLE	4.1 A

2 POSITIONS POWERED

Note:

Some lengths, styles and options are non-standard, non-returnable.

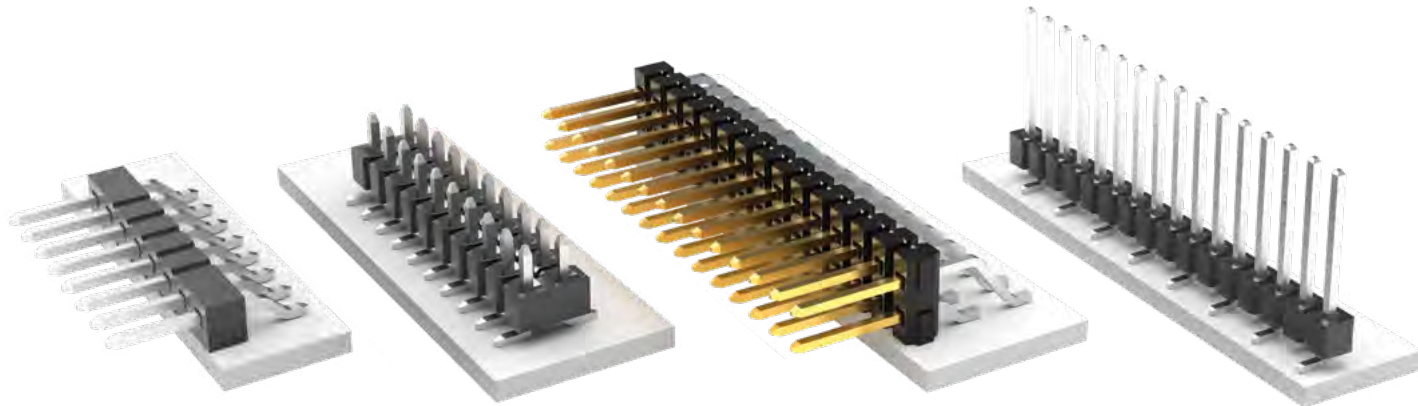

PLATING OPTION

- F**
= Gold flash on post, Matte Tin on tail
- L**
= 10 μ " (0.25 μ m) Gold on post, Matte Tin on tail
- S**
= 30 μ " (0.76 μ m) Gold on post, Matte Tin on tail
- T**
= Matte Tin

ROW OPTION

- SV**
= Single Row Vertical Pin
- DV**
= Double Row Vertical Pin
- SH**
= Single Row Horizontal Pin
- DH**
= Double Row Horizontal Pin (Style -01, -02 or -03 only)
- TM**
= Triple Row Vertical Mixed Technology (Style -01 only) (02 thru 30 positions only)
- MT**
= Mixed Technology Pin (Style -01, -02 or -03 only)

OTHER OPTIONS

- "XXX"**
= Polarized Position
- A**
= Alignment Pin metal or plastic at Samtec discretion (Not available with -TM or -MT) (02 positions minimum) (Not available with -LC)
- LC**
= Locking Clip (Not available with -TM) (3 positions minimum) (Not available with -A) (Manual placement required)
- K**
= (6.50 mm) .256" DIA Polyimide Film Pick & Place Pad (-SH: 4 positions minimum without -TR; 2 & 3 positions available with -TR) (-DH: 4 positions minimum without -TR)
- P**
= Plastic Pick & Place Pad (-DV: 4 positions minimum without -TR; 2 & 3 positions available with -TR) (-SH: 4 positions minimum without -TR; 2 & 3 positions available with -TR) (-DH: 5 positions minimum without -TR) (-SV: 4 positions minimum without -TR; 2 & 3 positions available with -TR)
- TR**
= Tape & Reel
-SV: 02-22 positions, -DV: 02-28 positions, -SH: 02-30 positions, -DH: 02-29 positions (Not available with -MT or -TM)
- FR**
= Full Reel Tape & Reel (must order maximum quantity per reel; contact Samtec for quantity breaks)
-SV: 02-22 positions, -DV: 02-28 positions, -SH: 02-30 positions, -DH: 02-29 positions (Not available with -MT or -TM)

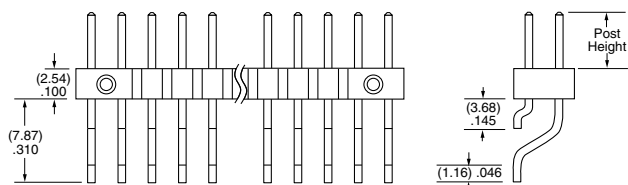
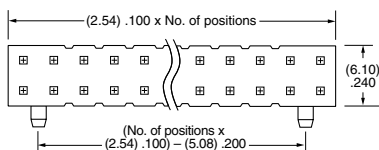

-DH Row Option

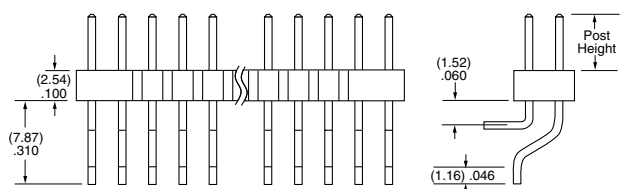
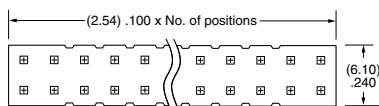

-MT Row Option

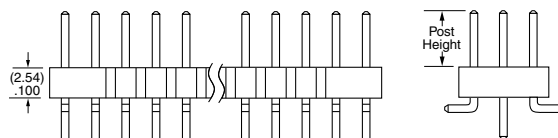
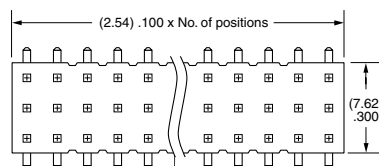

-TM Row Option

MODIFIED .025" SQ POST HEADERS

(2.54 mm) .100" PITCH • MTSW/HMTSW SERIES

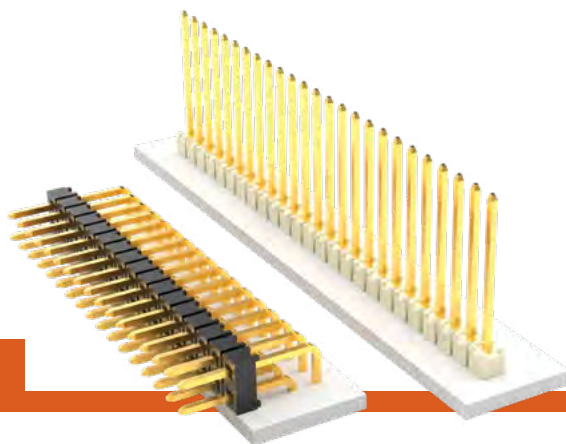

MTSW/HMTSW

Board Mates:

SSW, SSQ, ESW,
ESQ, BCS, BSW
CES, SLW, HLE, SSM

Cable Mates:

IDSD, IDSS

SPECIFICATIONS

Insulator Material:

MTSW: Black Glass
Filled Polyester
HMTSW: Natural Liquid
Crystal Polymer

Terminal Material:

Phosphor Bronze

Plating:

Au or Sn over
50 μ" (1.27 μm) Ni

Operating Temp Range:

-55 °C to +125 °C with Gold
-55 °C to +105 °C with Tin

PROCESSING

Lead-Free Solderable:

MTSW: No, Lead Wave Only
HMTSW: Yes

SERIES

MTSW
= Modified Strip

HMTSW
= Hi-Temp
Modified Strip

PIN CENTERS

-1
= (2.54 mm) .100" Pitch
(All positions filled)

-2
= (5.08 mm) .200" Pitch
(Every other position filled)

NO. PINS PER ROW

01 thru 50
= .100" (2.54 mm)
Center Version

02 thru 25
= .200" (5.08 mm)
Center Version

LEAD STYLE

Specify
LEAD STYLE
from chart

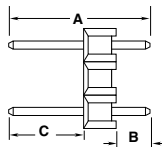
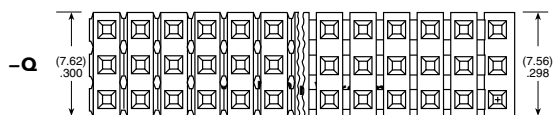
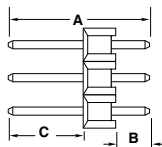
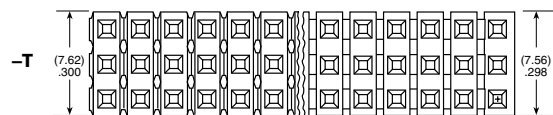
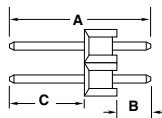
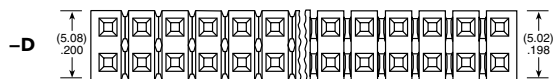
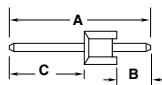
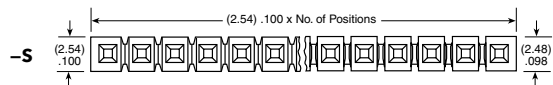

MTSW HMTSW

Straight Pin Versions

LEAD STYLE	A
-06	(7.62) .300
-07	(10.92) .430
-08	(13.46) .530
-09	(18.54) .730
-10	(21.08) .830
-11	(23.62) .930
-12	(26.16) 1.030
-13	(31.24) 1.230
-21	(36.32) 1.430
-22	(16.00) .630
-23	(11.30) .445
-24	(12.19) .480
-27	(33.78) 1.330
-28	(28.70) 1.130

FOR "B" = (2.29) .090

LEAD STYLE	C MAXIMUM STRAIGHT
-06	(2.79) .110
-07	(6.10) .240
-08	(8.64) .340
-09	(13.72) .540
-10	(16.26) .640
-11	(18.80) .740
-12	(21.34) .840
-13	(26.42) 1.040
-21	(31.50) 1.240
-22	(11.18) .440
-23	(6.48) .255
-24	(7.37) .290
-27	(28.96) 1.140
-28	(23.88) .940

Note:

These Series are
non-standard, non-returnable.

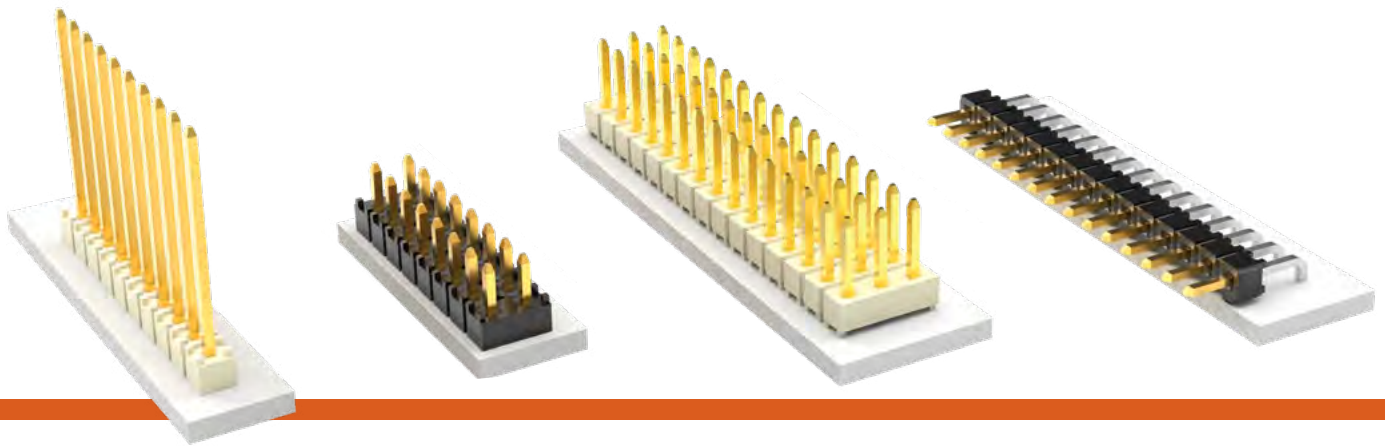

PLATING OPTION

-F
= Gold flash on post,
Matte Tin on tail

-L
= 10 μ" (0.25 μm)
Gold on post,
Matte Tin on tail

-G
= 10 μ" (0.25 μm)
Gold on post,
Gold flash on balance

-T
= Matte Tin

ROW OPTION

-S
= Single Row

-D
= Double Row

-T
= Triple Row

-Q
= Double Row
.200" (5.08 mm)
row space

POST HEIGHT

"XXXX"
= "C" Dimension
(Specify post height in
INCHES
.005" (0.13 mm) increments)

OTHER OPTION

-RA or -RE
= Right-angle

-LL
= Locking Lead
(not available with -RE, not available
in single row 1 or 2 positions)
(Available on tails from (2.29 mm) .090"
to (10.16 mm) .400" only)

-LA
= -RA option with -LL Option
(Maximum "C" = (13.46 mm) .530")

POLARIZED OPTION

"XXX"
= Polarized
(Specify 'XXX' as position number)

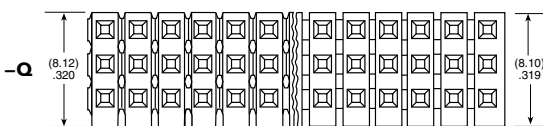
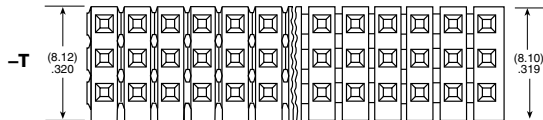
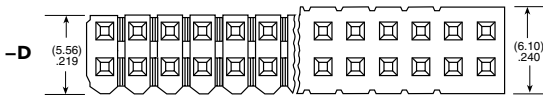
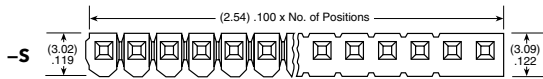

MTSW

HMTSW

Right-Angle Versions (-RA Options)

Right-Angle Versions (-RE Options) Single Row Only

(HMTSW -S & -D = 36 positions maximum)

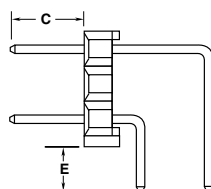
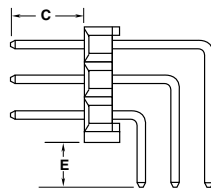
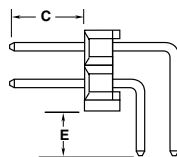
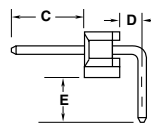

-RX OPTION	D
-RA	(1.52) .060
-RE	(4.06) .160

FOR "E" = (2.29) .090 MIN FOR -RA & -RE		
LEAD STYLE	C MAXIMUM with/-RA	C MAXIMUM with/-RE
-06	Not Available	Not Available
-07	(3.30) .130	Not Available
-08	(5.84) .230	(3.30) .130
-09	(10.92) .430	(8.38) .330
-10	(13.46) .530	(10.92) .430
-11	(16.00) .630	(13.46) .530
-12	(18.54) .730	(16.00) .630
*-13	(23.62) .930	(21.08) .830
*-21	(28.70) 1.130	(26.16) 1.030
-22	(8.38) .330	(5.84) .230
*-23	(3.68) .145	Not Available
*-24	(4.57) .180	
*-27	(26.16) 1.030	(23.62) .930
*-28	(21.08) .830	(18.54) .730

* Styles -21, -23, -24, -27 not available with -D Right-angle
Styles -13, -21, -23, -24, -27, -28 not available with -T or -Q Right-angle

FLEX STACK

LOW-PROFILE .025" SQ POST HEADERS

(2.54 mm) .100" PITCH • TLW/MTLW SERIES

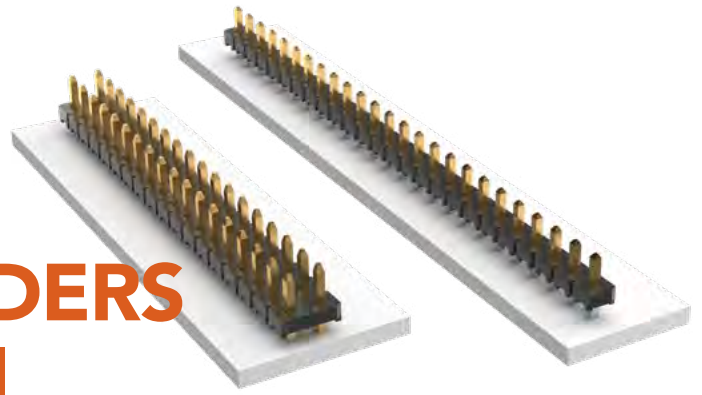

TLW/MTLW

Board Mates:
BSW, CES, SLW, HLE

FEATURES

These headers provide the ultimate low-profile (0.64 mm) .025" square post board stacking system. The high quality Phosphor Bronze terminals are available with a standard short post height (TLW Series) for mating with low-profile sockets, or the post height can be Modified (MTLW Series) to accommodate IDC assemblies and other applications.

SPECIFICATIONS

Insulator Material:
Black Liquid Crystal Polymer
Terminal Material:
Phosphor Bronze
Plating:
Au or Sn over
50 μ" (1.27 μm) Ni
Current Rating (TLW/SLW):
5.2 A per pin
(2 pins powered)
Operating Temp Range:
-55 °C to +105 °C with Tin
-55 °C to +125 °C with Gold

PROCESSING

Lead-Free Solderable:
Yes

ALSO AVAILABLE

MOQ Required

Other platings
Notch option

Note:
Some lengths, styles and options are non-standard, non-returnable. MTLW Series is non-standard, non-returnable.

TLW	- 1	NO. PINS PER ROW	LEAD STYLE	PLATING OPTION	ROW OPTION	OTHER OPTION
-----	-----	------------------	------------	----------------	------------	--------------

01 thru 40
= Single Row
01 thru 36
= Double Row

Specify **LEAD STYLE** from chart

-F
= Gold flash on post, Matte Tin on tail
-G
= 10 μ" (0.25 μm) Gold on post, Gold flash on tail
-T
= Matte Tin

-S
= Single Row
-D
= Double Row

-RA
= Right-angle (-01 Lead Style only)
"-XX"
= Polarized Position Specify position for omitted pin.

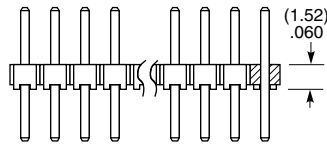
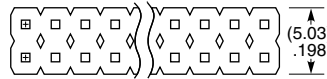
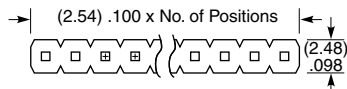

-05 & -06

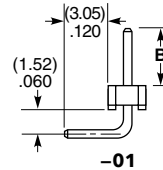

LEAD STYLE	A	B
-01	N/A	(5.84) .230
-05	(4.32) .170	(2.67) .105
-06	(3.43) .135	

MTLW	- 1	NO. PINS PER ROW	LEAD STYLE	PLATING OPTION	ROW OPTION	POST HEIGHT
------	-----	------------------	------------	----------------	------------	-------------

01 thru 40
= Single Row
01 thru 36
= Double Row

Specify **LEAD STYLE** from chart

-F
= Gold flash on post, Matte Tin on tail
-L
= 10 μ" (0.25 μm) Gold on post, Matte Tin on tail
-G
= 10 μ" (0.25 μm) Gold on post, Gold flash on tail
-T
= Matte Tin

-S
= Single Row
-D
= Double Row

"-XXX"
= Post Height Dimension (In inches)

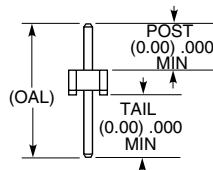
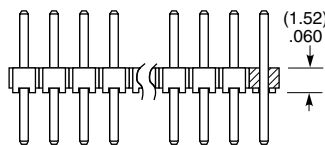
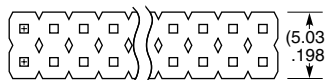
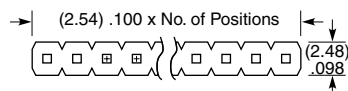

LEAD STYLE	OAL
-05	(8.51) .335
-06	(7.62) .300
-07	(10.92) .430
-08	(13.46) .530
-09	(18.54) .730
-10	(21.08) .830
-22	(16.00) .630
-23	(11.30) .445
-24	(12.19) .480

FLEX STACK

FLEXIBLE .025" SQ BOARD STACKERS

(2.54 mm) .100" PITCH • HW SERIES

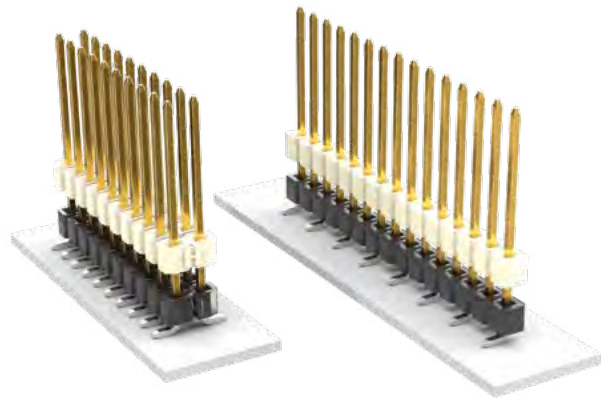

HW

Board Mates:

SSW, SSQ, ESW, ESQ, CES, SLW, BSW, BCS, SSM, HLE, PHF

Cable Mates:

IDSS, IDSD

SPECIFICATIONS

Insulator Material:

HW-SM Top = Natural LCP
HW-SM Bottom = Black LCP
HW-TH = Natural LCP

Terminal Material:

Phosphor Bronze

Plating:

Au or Sn over
50 μ" (1.27 μm) Ni

Operating Temp Range:

-55 °C to +125 °C with Gold
-55 °C to +105 °C with Tin

PROCESSING

Lead-Free Solderable:

Yes

SMT Lead Coplanarity:

(0.15 mm) .006" max*
*(.004" stencil solution may be available; contact IPG@samtec.com)

ALSO AVAILABLE MOQ Required

Other platings

Locking Clip available with double row HW-SM
(Manual placement required)

Notes:

For added mechanical stability, Samtec recommends mechanical board spacers be used in applications with gold or selective gold plated connectors. Contact ipg@samtec.com for more information.

This Series is non-standard, non-returnable.

HW	NO. PINS PER ROW	LEAD STYLE	PLATING OPTION	ROW OPTION	STACKER HEIGHT	SM	OTHER OPTION
----	------------------	------------	----------------	------------	----------------	----	--------------

01 thru 50
(Through-hole)

02 thru 36
(Surface mount)

Specify LEAD STYLE from chart

-F
= Gold flash on contact, Matte Tin on tail

-L
= 10 μ" (0.25 μm) Gold on contact area of longer tail, Matte Tin on tail

-G
= 10 μ" (0.25 μm) Gold on contact area of longer tail, Gold flash on balance

-T
= Matte Tin

-S
= Single Row

-D
= Double Row

-T
= Triple Row (Through-hole only)

-Q
= Double Row .200" (5.08 mm) row space (Through-hole only)

-"XXX"
= Stacker Height (in inches)

Through-hole = (5.08 mm) .200" Min.

Surface mount = (6.35 mm) .250" Min.

Leave blank for Through-hole

-"XXX"

= HW-TH Tail Length (in inches) (1.40 mm) .055" min. Example: -250 = (6.35 mm) .250"

-LL

= Locking Lead (Through-hole only) (Shortest dimension between the tail and the post is the end that will be crimped. Available on tails from (2.29 mm) .090" to (7.87 mm) .310" only.) Single row, 01 & 02 positions & -Q row not available

-"XXX"
= Polarized (Specify omitted pin position)

-A
= Alignment Pin (Metal or plastic at Samtec discretion) (Surface mount only)

-TR

= Tape & Reel (4-27 pins per row only) (Not Available on Lead Styles 10, 11, 12 & 20) (Surface mount only)

-FR

= Full Reel Tape & Reel (must order max. quantity per reel; contact Samtec for quantity breaks) (4-27 pins per row only) (Not Available on Lead Styles 10, 11, 12 & 20) (Surface mount only)

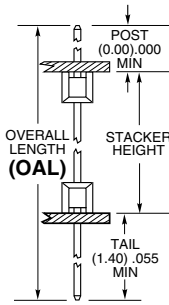

LEAD STYLE	OAL (TH)
-07	(10.92) .430
-08	(13.46) .530
-09	(18.54) .730
-10	(21.08) .830
-11	(23.62) .930
-12	(26.16) 1.030
-13	(31.24) 1.230
-14	(36.32) 1.430
-15	(16.00) .630
-16	(11.30) .445
-17	(12.19) .480
-19	(33.78) 1.330
-20	(28.70) 1.130

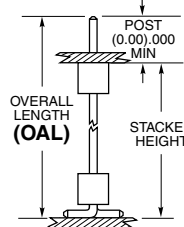

LEAD STYLE	OAL (SMT)
-08	(11.81) .465
-09	(16.89) .665
-10	(19.43) .765
-11	(21.97) .865
-12	(24.51) .965
-15	(14.35) .565
-16	(9.65) .380
-17	(10.54) .415
-20	(27.05) 1.065

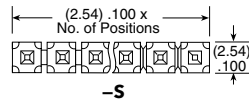

-S

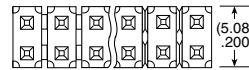

-D

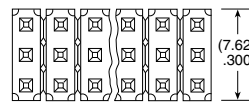

-T or -Q*

-Q* same as -T except middle row pins are removed

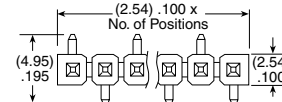

-S

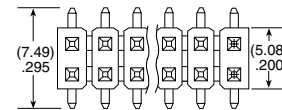

-D

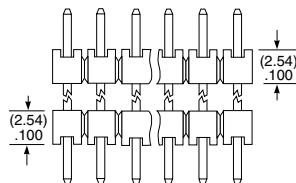

HW-TH

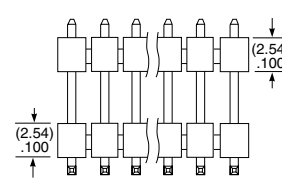

HW-SM

FLEX STACK

FLEXIBLE .025" SQ BOARD STACKERS

(2.54 mm) .100" PITCH • DW/EW/ZW SERIES

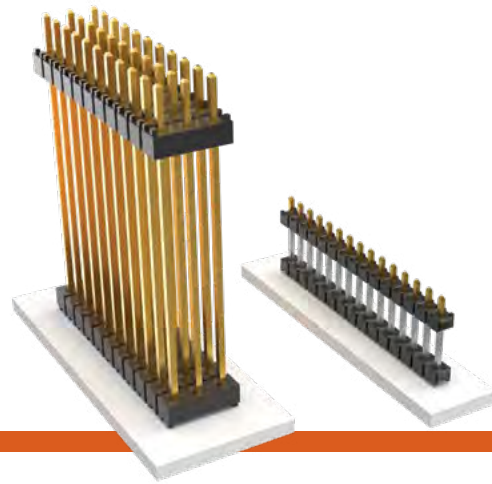

DW/EW/ZW

Board Mates:

SSW, SSQ, ESW, ESQ,
CES, SLW, BSW, BCS,
SSM, HLE, PHF

Cable Mates:

IDSS, IDSD

SPECIFICATIONS

Insulator Material:

Black Glass Filled Polyester

Terminal Material:

Phosphor Bronze

Plating:

Au or Sn over
50 μ" (1.27 μm) Ni

Operating Temp Range:

-55 °C to +125 °C with Gold
-55 °C to +105 °C with Tin

PROCESSING

Lead-Free Solderable:

No, Lead Wave Only

SERIES	NO. PINS PER ROW	LEAD STYLE	PLATING OPTION	ROW OPTION	STACKER HEIGHT	OTHER OPTION
DW = (2.79 mm) .110" Tail	01 thru 50	Specify LEAD STYLE from chart	-F = Gold flash on contact, Matte Tin on tail	-S = Single Row	-"XXX" = Stacker Height (in inches) (5.08 mm) .200" minimum	-"XXX" = ZW Tail Length (in inches) (1.40 mm) .055" minimum
EW = (8.38 mm) .330" Tail			-L = 10 μ" (0.25 μm) Gold on contact area of longer tail, Matte Tin on tail	-D = Double Row	Example: -250 = (6.35 mm) .250"	Example: -250 = (6.35 mm) .250"
ZW = Custom Tail			-G = 10 μ" (0.25 μm) Gold on contact area of longer tail, Gold flash on balance	-T = Triple Row		-LL = Locking Lead (Shortest dimension between the tail and the post is the end that will be crimped. Available on tails from (2.29 mm) .090" to (7.87 mm) .310" only.) Single row, 01 & 02 positions & -Q row not available
			-T = Matte Tin	-Q = Double Row .200" (5.08 mm) row space		-"XXX" = Polarized (Specify omitted pin position)

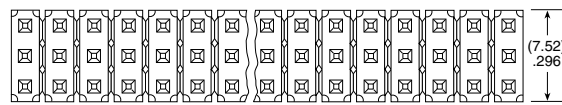
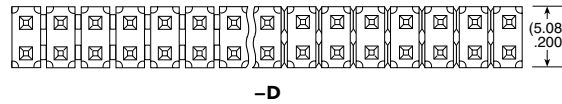
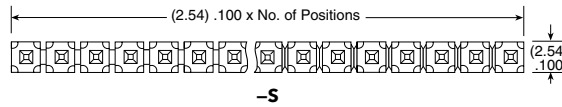

-Q* same as -T except middle row pins are removed

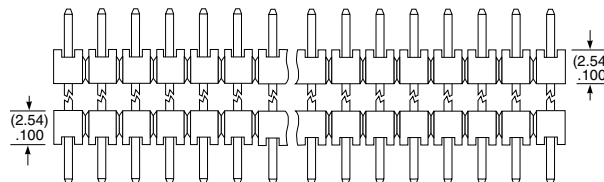

LEAD STYLE	OAL
-07	(10.92) .430
-08	(13.46) .530
-09	(18.54) .730
-10	(21.08) .830
-11	(23.62) .930
-12	(26.16) 1.030
-13	(31.24) 1.230
-14	(36.32) 1.430
-15	(16.00) .630
-16	(11.30) .445
-17	(12.19) .480
-19	(33.78) 1.330
-20	(28.70) 1.130

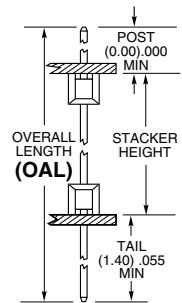

Notes:

For added mechanical stability, Samtec recommends mechanical board spacers be used in applications with gold or selective gold plated connectors. Contact jpg@samtec.com for more information.

This Series is non-standard, non-returnable.

SHROUDED .025" SQ POST HEADERS

(2.54 mm) .100" PITCH • TSS/HTSS/ZSS SERIES

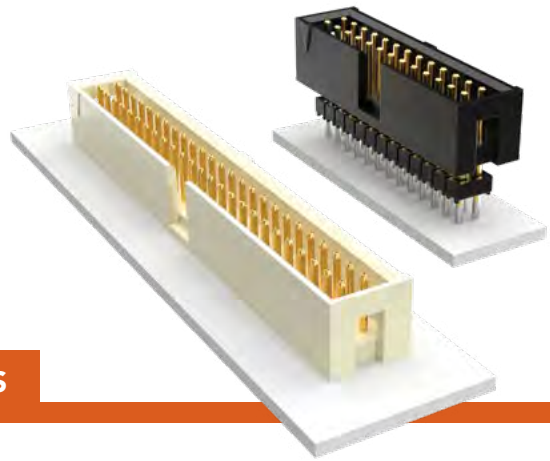

TSS/HTSS/ZSS

Mates:
SSW, SSQ, ESW, ESQ,
SSM, BCS

SPECIFICATIONS

Insulator Material:
TSS, ZSS=Black Glass Filled Polyester
HTSS=Natural PCT
Insulation Resistance:
5000 MΩ min
Terminal Material:
Phosphor Bronze
Plating: Au or Sn over 50 μ" (1.27 μm) Ni
Operating Temp Range:
-55 °C to +125 °C with Gold
-55 °C to +105 °C with Tin
Withstanding Voltage:
1000 VRMS

PROCESSING

Lead-Free Solderable:
HTSS=Yes
TSS, ZSS=No, Lead Wave only
SMT Lead Coplanarity:
(0.15 mm) .006" max*
*(.004" stencil solution may be available; contact ipg@samtec.com)

SERIES	1	NO. PINS PER ROW	LEAD STYLE	PLATING OPTION	ROW OPTION
--------	---	------------------	------------	----------------	------------

TSS
= Connector Strip
HTSS
= High Temp Connector Strip

03
(TSS only)
05, 07, 08, 10, 12, 13, 15, 17, 20, 25, 32, 36
(Standard sizes)

Specify LEAD STYLE from chart

-F
= Gold flash on post, Matte Tin on tail
(Not available on -DV)

-L
= 10 μ" (0.25 μm) Gold on post, Matte Tin on tail

-T
= Matte Tin

-D
= Double Row Through-hole (lead style -01, -02 & -03 only)

-DV
= Double Row Surface Mount (lead style -01 only) (HTSS only)

-D-RA
= Double Row Right-angle (lead style -04 & -05 only)

LEAD STYLE	T/H (A)
-01	(2.92) .115
-02	(4.19) .165
-03	(14.35) .565

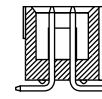
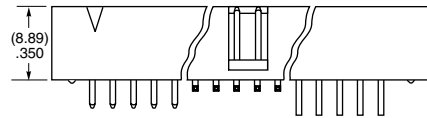
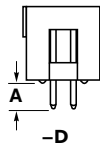
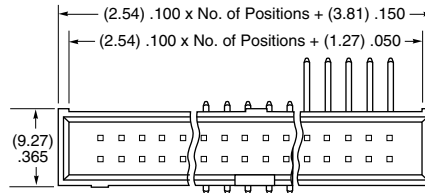

-DV
(HTSS ONLY)

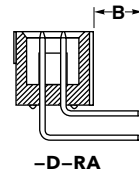

-D-RA

LEAD STYLE	RIGHT ANGLE (B)
-04	(3.30) .130
-05	(5.84) .230

ZSS	1	NO. PINS PER ROW	LEAD STYLE	PLATING OPTION	D	BODY HEIGHT
-----	---	------------------	------------	----------------	---	-------------

03, 05, 07, 08, 10, 12, 13, 15, 17, 20, 25, 32, 36
(Standard sizes)

Specify LEAD STYLE from chart

-F
= Gold flash on post, Matte Tin on tail

-L
= 10 μ" (0.25 μm) Gold on post, Matte Tin on tail

-T
= Matte Tin

-"XXXX"
= Body Height

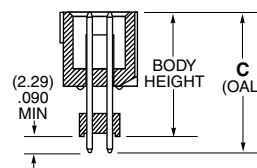
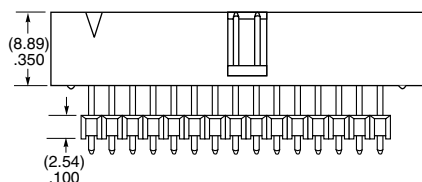
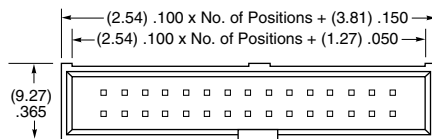

LEAD STYLE	C (OAL)	MAX BODY HEIGHT
-01	(16.00) .630	(13.72) .540
-02	(18.54) .730	(16.26) .640
-03	(21.08) .830	(18.80) .740
-04	(23.62) .930	(21.34) .840
-05	(26.16) 1.030	(23.88) .940
-06	(28.70) 1.130	(26.42) 1.040
-07	(31.24) 1.230	(28.96) 1.140
-08	(33.78) 1.330	(31.50) 1.240
-09	(36.32) 1.430	(34.04) 1.340

Note:
Some lengths, styles and options are non-standard, non-returnable. ZSS is non-standard, non-returnable.

Note:
For added mechanical stability, Samtec recommends mechanical board spacers be used in applications with gold or selective gold plated connectors. Contact ipg@samtec.com for more information.

THROUGH-HOLE .025" SQ POST SOCKET

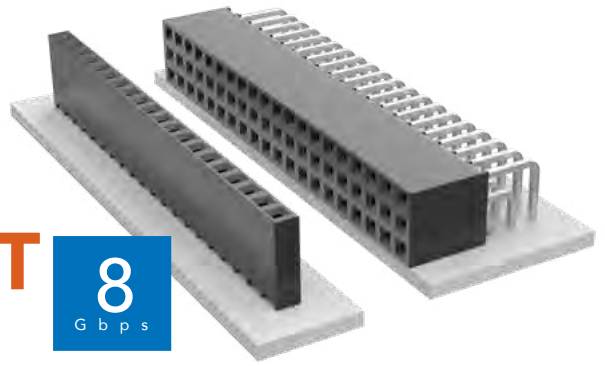

(2.54 mm) .100" PITCH • SSW/SSQ SERIES

SSW/SSQ

Mates:

TSW, MTSW, MTLW,
DW, EW, ZW, TSS, ZSS,
TSM, TSSH, HTSS

SPECIFICATIONS

Insulator Material:

Black Liquid Crystal Polymer (-S & -D) or
Black High Temperature Thermoplastic (-T)

Contact Material:

Phosphor Bronze

Plating:

Au or Sn over

50 μ" (1.27 μm) Ni

Current Rating (SSW/TSW):

4.7 A per pin

(2 pins powered)

Current Rating (SSQ/TSW):

6.3 A per pin

(2 pins powered)

Operating Temp Range:

-55 °C to +125 °C with Gold

-55 °C to +105 °C with Tin

Insertion Depth:

(3.68 mm) .145" to

(6.35 mm) .250"

Normal Force:

Standard= 125 grams (4.4 N)

Max Cycles:

100 with 10 μ" (0.25 μm) Au

Voltage Rating:

465 VAC / 655 VDC

PROCESSING

Lead-Free Solderable:

Yes:

-S and -D row option

No, Lead Wave only:

-P, -T and -Q row option

SERIES	1	NO. PINS PER ROW	LEAD STYLE	PLATING OPTION	ROW OPTION	TAIL OPTION	OTHER OPTION
--------	---	------------------	------------	----------------	------------	-------------	--------------

SSW
= Solder Tail

01 thru 50

Specify
LEAD STYLE
from chart

-F
= Gold flash on contact,
Matte Tin on tail

-S
= Single Row

Leave blank for straight pin version)

-LL
= Locking Lead

SSQ
= Square Tail

-L
= 10 μ" (0.25 μm)
Gold on contact,
Matte Tin on tail

-P
= Single Row
(36 pins max)

-RA
= Right-angle

Available on tails from
(2.29 mm) .090" to
(7.87 mm) .310" only.
Not Available with single row 1 or 2 positions)

-G
= 20 μ" (0.51 μm)
Gold on contact,
Gold flash on tail

-D
= Double Row

-T
= Triple Row

-Q
= Double Row
".200"
(5.08 mm) row space
(outer rows filled only)

"XXX"
= Polarized
(Specify "XXX" as position number)

-T
= Matte Tin
(-T N/A on LIF contacts)

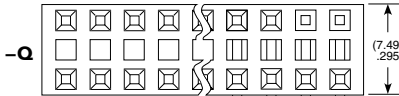
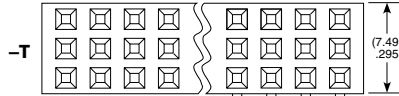
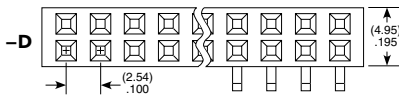
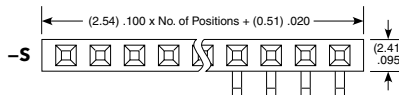

Through-hole

Right-Angle

THROUGH-HOLE		
LEAD STYLE		SINGLE DOUBLE OR TRIPLE
Standard Insertion Force	Low Insertion Force*	
-01	-21	(2.64) .104
-02	-22	(4.93) .194
-03	-24	(10.00) .394
-04	-24	(14.83) .584
-06**	N/A	(3.15) .124

* LIF not available with Tin Plating

**Style -06 Not available with SSQ

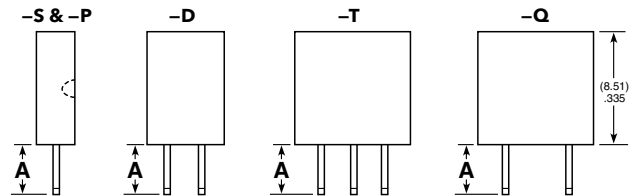

Straight Pin Versions

RIGHT-ANGLE				
LEAD STYLE		SINGLE	DOUBLE	TRIPLE
Standard Insertion Force	Low Insertion Force*	(-S) B	(-D) B	(-T & -Q) B
-02	-22	(2.54) .100	(2.54) .100	(2.54) .100
-03	-23	(7.62) .300	(7.62) .300	N/A
-04	-24	(12.45) .490	N/A	N/A

*LIF not available with Tin Plating

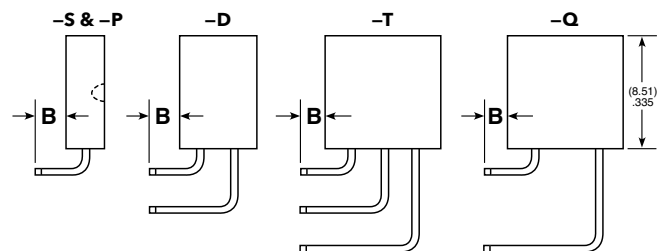

Right-Angle Versions

Note:

Some lengths, styles and options are non-standard, non-returnable.

SURFACE MOUNT .025" SQ POST SOCKET

(2.54 mm) .100" PITCH • SSW SERIES

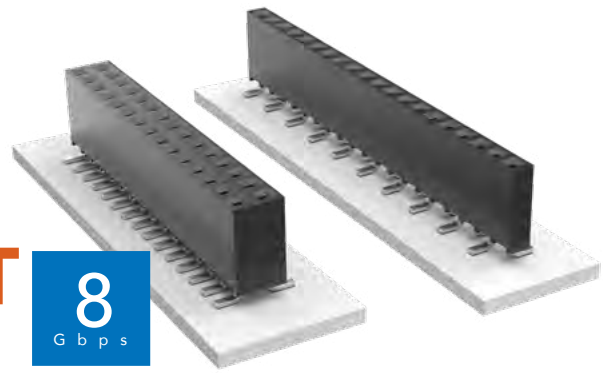

SSW

Mates:

TSW, MTSW, HTSW,
HMTSW, MTLW, EW, ZW,
TSS, HTSS, ZSS, TSM,
TSSH, DW, HW

SPECIFICATIONS

Insulator Material:

Black LCP

Contact Material:

Phosphor Bronze

Plating:

Au or Sn over

50 μ" (1.27 μm) Ni

Current Rating (SSW/TSM):

4.7 A per pin

(2 pins powered)

Operating Temp Range:

-55 °C to +125 °C with Gold

-55 °C to +105 °C with Tin

Insertion Depth:

(3.68 mm) .145" to

(6.35 mm) .250"

Max Cycles:

100 with 10 μ" (0.25 μm) Au

Voltage Rating:

465 VAC / 655 VDC

PROCESSING

Lead-Free Solderable:

Yes

SMT Lead Coplanarity:

(0.10 mm) .004" max

ALSO AVAILABLE

MOQ Required

Other platings

Notch option

SSW	1	NO. PINS PER ROW	22	PLATING OPTION	ROW OPTION	VS	OTHER OPTION
		02 thru 36		<p>-F = Gold flash on contact, Matte Tin on tail</p> <p>-L = 10 μ" (0.25 μm) Gold on contact, Matte Tin on tail</p> <p>-G = 20 μ" (0.51 μm) Gold on contact, Gold flash on tail</p>	<p>-S = Single Row</p> <p>-D = Double Row</p>		<p>-XX = Polarized Position</p> <p>-K = -S: (3.50 mm) .138" DIA, -D: (6.50 mm) .256" DIA Polyimide film Pick & Place Pad (03 positions min.)</p> <p>-P = Pick & Place Pad (05 positions min.)</p> <p>-TR = Tape & Reel (-02 thru -28)</p> <p>-FR = Full Reel Tape & Reel (must order max. quantity per reel; contact Samtec for quantity breaks) (-02 thru -28)</p>

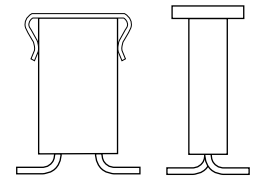
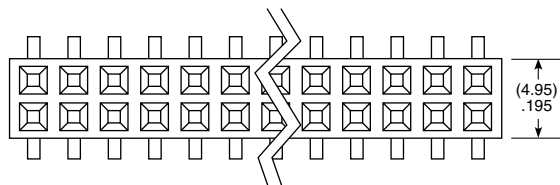
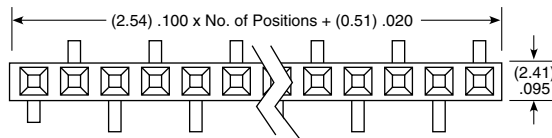

-P OPTION

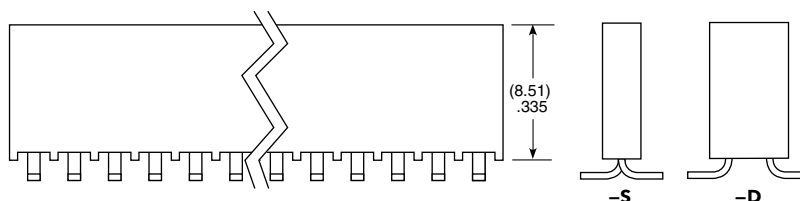

Note:

Some lengths, styles and options are non-standard, non-returnable.

TIGER CLAW™ SURFACE MOUNT SOCKET

(2.54 mm) .100" PITCH • SSM SERIES

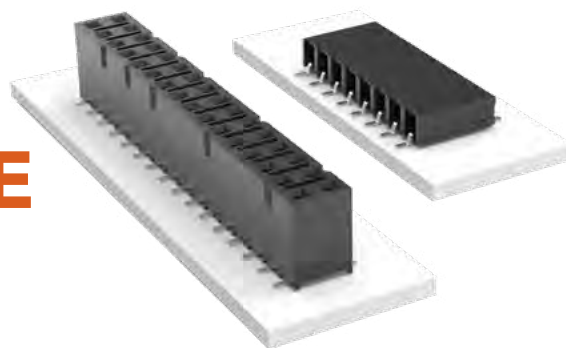

SSM

Mates:

TSW, MTSW,
TST, TSS, ZST, ZSS,
DW, EW, ZW, TSM,
HMTSW, HTSW, TSSH,
BST, HTSS, TLW, MTLW

SPECIFICATIONS

Insulator Material:

Black Liquid Crystal Polymer

Contact Material:

Phosphor Bronze

Plating:

Au or Sn over
50 μ" (1.27 μm) Ni

Current Rating (SSM/TSW):

5.2 A per pin
(2 pins powered)

Voltage Rating:

405 VAC / 572 VDC

Operating Temp Range:

-55 °C to +125 °C with Gold
-55 °C to +105 °C with Tin

Insertion Depth:

SV/DV = (4.34 mm) .171" to
(7.24 mm) .285" or pass-through
from top; (5.56 mm) .219"
plus board thickness minimum
from bottom;

SH/DH = (4.34 mm) .171" to
(6.35 mm) .250"

Normal Force:

125 grams (1.21 N) average

PROCESSING

Lead-Free Solderable:

Yes

-DH Coplanarity:

Less than 28 positions

(0.15 mm) .006" max*

More than 27 positions

(0.20 mm) .008" max*

-SH, -SV, -DV Coplanarity:

(0.15 mm) .006" max*

*(.004" stencil solution

may be available; contact

IPG@samtec.com)

ALSO AVAILABLE

Alignment pin
(MOQ Required)



Note:
Some lengths, styles and
options are non-standard,
non-returnable.

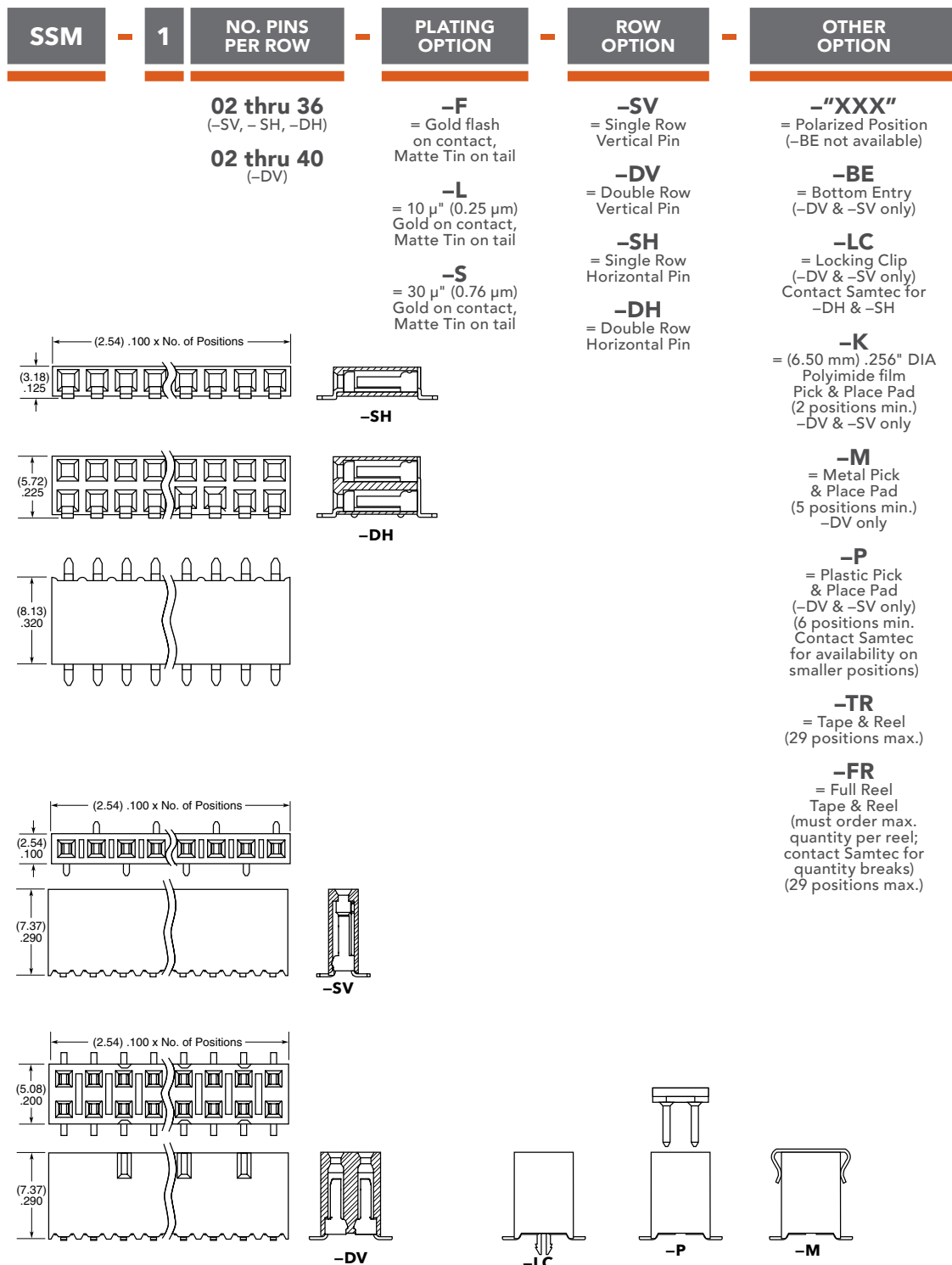

ELEVATED SOCKETS

(2.54 mm) .100" PITCH • ESW/ESQ SERIES

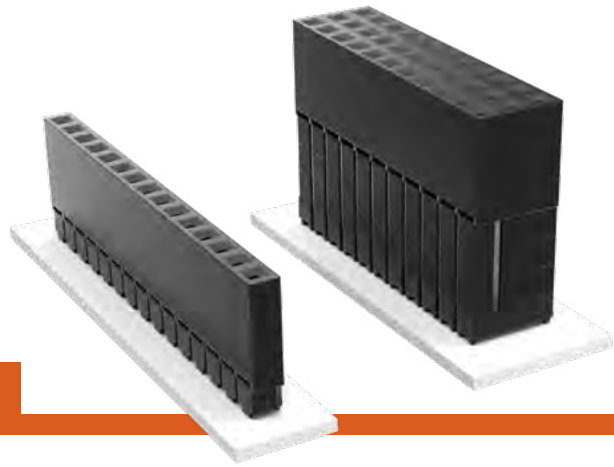

ESW/ESQ

Mates:

TSW, MTSW, EW, MTLW, TSS, ZSS, TSM, DW, ZW, HW, TSSH, HTSS

SPECIFICATIONS

Insulator Material:

Black Glass Filled Polyester

Contact Material:

Phosphor Bronze

Plating:

Au or Sn over 50 μ" (1.27 μm) Ni

Current Rating (ESW/TSW):

5.2 A per pin (2 pins powered)

Current Rating (ESQ/TSW):

5.7 A per pin (2 pins powered)

Voltage Rating:

550 VAC mated with TSW or ESQ

Operating Temp Range:

-55 °C to +125 °C with Gold

-55 °C to +105 °C with Tin

Insertion Depth:

(3.68 mm) .145" to (6.35 mm) .250"

Normal Force:

Standard = 125 grams (4.4 N)

Max Cycles:

100 with 10 μ" (0.25 μm) Au

SERIES	1	NO. PINS PER ROW	LEAD STYLE	PLATING OPTION	ROW OPTION	OTHER OPTION
--------	---	------------------	------------	----------------	------------	--------------

ESW
= Solder Tail

01 thru 36

Specify **LEAD STYLE** from chart

-L
= 10 μ" (0.25 μm) Gold contact, Matte Tin on tail

-S
= Single Row

-LL
= Locking Lead (Two leads per strip crimped. Not available with single row 1 or 2 positions)

ESQ
= Square Tail

-G
= 20 μ" (0.51 μm) Gold contact, Gold Flash on Balance

-D
= Double Row

-T
= Triple Row (ESQ only)

"XXX"
= Polarized

-T
= Matte Tin (Not available with LIF contact)

LEAD STYLE			
STANDARD INSERTION FORCE	Low INSERTION FORCE	A	B
-12	-37	(2.29) .090	(11.05) .435
-13	-38	(7.36) .290	
-23	-48	(4.83) .190	(13.59) .535
-33	-58	(2.29) .090	(16.13) .635
-14	-39	(12.19) .480	(11.05) .435
-24	-49	(9.65) .380	(13.59) .535
-34	-59	(7.11) .280	(16.13) .635
-44	-69	(4.57) .180	(18.67) .735

PROCESSING

Lead-Free Solderable:

No, Lead Wave only

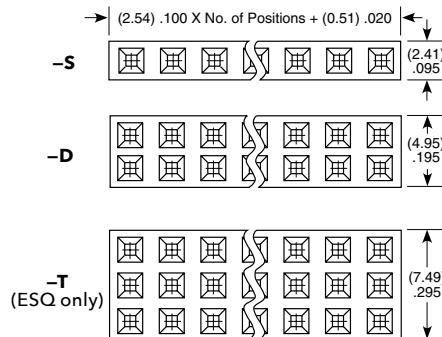

APPLICATIONS

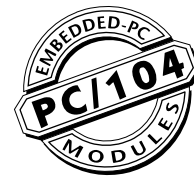

Self Nesting Sockets

(ESQ SERIES)

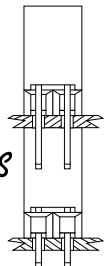

ALSO AVAILABLE

Other Plating (MOQ Required)

Note:

Some lengths, styles and options are non-standard, non-returnable.

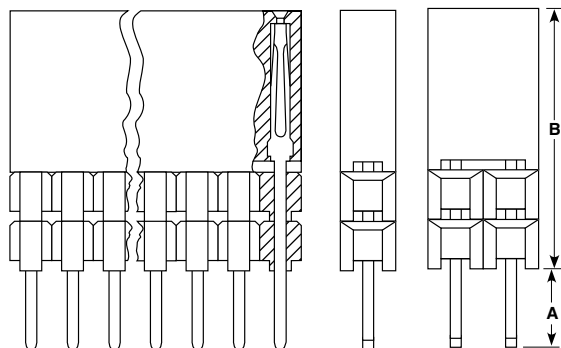

PC/104™ J1/P1 "Stackthrough" Connectors	
Standard Insertion Force	ESQ-132-14-G-D
Low Insertion Force	ESQ-132-39-G-D
PC/104™ J1 "Non-Stackthrough" Connectors	
Standard Insertion Force	ESQ-132-12-G-D
Low Insertion Force	ESQ-132-37-G-D
PC/104™ J2/P2 "Stackthrough" Connectors	
Standard Insertion Force	ESQ-120-14-G-D
Low Insertion Force	ESQ-120-39-G-D

PC/104 is a trademark of the PC/104 Consortium.

COST-EFFECTIVE RELIABLE SOCKET

(2.54 mm) .100" PITCH • HLE SERIES

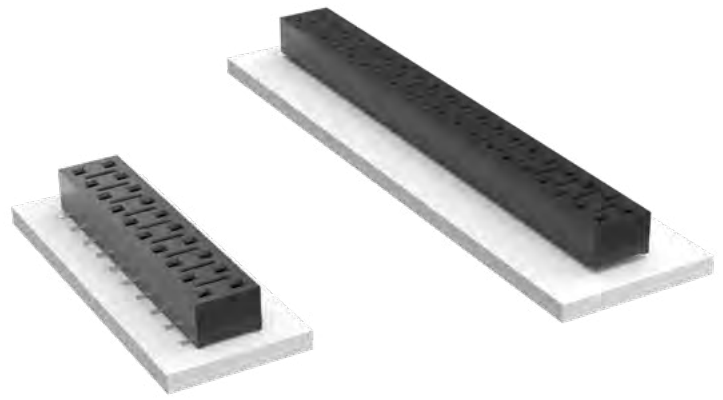

HLE

Board Mates:

TSW, MTSW, DW, EW,
ZW, TLW, TSM, MTLW, HW

SPECIFICATIONS

Insulator Material:

Black Liquid Crystal Polymer

Contact Material:

BeCu

Plating:

Au or Sn over
50 μ" (1.27 μm) Ni

Current Rating (HLE/TSM):

4.1 A per pin
(2 pins powered)

Voltage Rating:

400 VAC

Operating Temp Range:

-55 °C to +125 °C

Insertion Depth:

(1.78 mm) .070" to
(3.43 mm) .135" pass-through,
or (2.59 mm) .102" min
plus board thickness for
bottom entry

PROCESSING

Lead-Free Solderable:

Yes

SMT Lead Coplanarity:

(0.10 mm) .004" max (02-20)
(0.15 mm) .006" max (21-50)*
*(.004" stencil solution
may be available; contact
IPG@samtec.com)

ALSO AVAILABLE

Other Platings
(MOQ Required)

Note:

Some lengths, styles and
options are non-standard,
non-returnable.



02 thru 50

-F
= Gold flash on
contact,
Matte Tin on tail

-L
= 10 μ" (0.25 μm)
Gold on contact,
Matte Tin on tail

Leave blank for
Surface Mount
(Requires -BE for
Bottom Entry)

-TE
= Through-hole
Top Entry

-PE
= Through-hole
Pass-through
Entry
(Requires -BE for
Bottom Entry)

-BE
= Bottom Entry
(Not available
with -TE)

-A
= Alignment Pin
(4 positions min.)
Metal or plastic at
Samtec discretion
(Not available with
-TE, -PE & -LC)

-LC
= Locking Clip
(2 positions min.)
(Not available with -A)
(Manual placement
required)

-K
= (6.50 mm)
.256" DIA
Polyimide Film
Pick & Place Pad
(3 positions min.)
Not available
with -TE or
-PE tail option

-P
= Metal Pick
& Place Pad
(3 positions min.)

-TR
= Tape & Reel
(29 positions max.)

-FR
= Full Reel
Tape & Reel
(must order max.
quantity per reel;
contact Samtec for
quantity breaks)

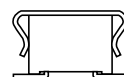
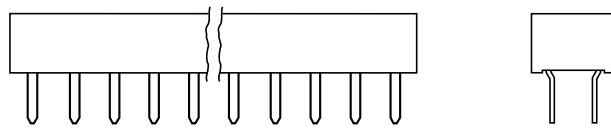
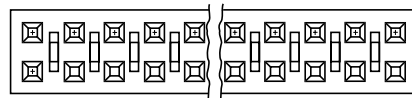
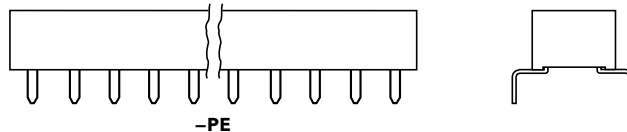
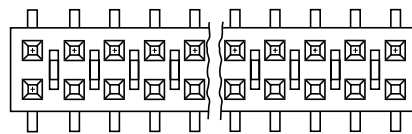
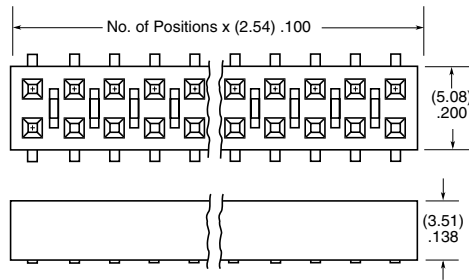

-P



-LC



-A

TIGER CLAW™ PASS-THROUGH SOCKET

(2.54 mm) .100" PITCH • BCS SERIES

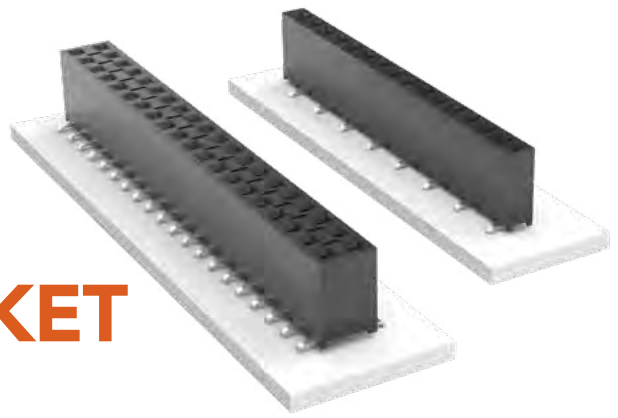

BCS

Mates:

TSW, MTSW, HTSW,
HMTSW, TSS, ZSS, DW, EW,
ZW, HW, TSM, MTLW, PHT

SPECIFICATIONS

Insulator Material:

Black Liquid Crystal Polymer

Contact Material:

Phosphor Bronze

Plating:

Au or Sn over
50 μ" (1.27 μm) Ni

Current Rating (BCS/TSW):

4.6 A per pin
(2 pins powered)

Voltage Rating:

475 VAC
(-TE/-DE/-PE mated with TSM)

450 VAC

(-HE mated with TSW)

Operating Temp Range:

-55 °C to +125 °C

Insertion Depth:

(4.34 mm) .171" to
(7.24 mm) .285" from top,
(5.64 mm) .222" plus board
thickness minimum from bottom.
-HE is (4.34 mm) .171"
to (6.35 mm) .250"

PROCESSING

Lead-Free Solderable:

Yes

ALSO AVAILABLE

Other Platings
(MOQ Required)

BCS	1	NO. PINS PER ROW	PLATING OPTION	ROW OPTION	ENTRY OPTION	OTHER OPTION
		01 thru 50	<p>-F = Gold flash on contact, Matte Tin on tail</p> <p>-L = 10 μ" (0.25 μm) Gold on contact, Matte Tin on tail</p>	<p>-S = Single</p> <p>-D = Double</p>	<p>-TE = Top Entry</p> <p>-DE = Top Entry (For Bottom Entry specify -DE-BE) Cannot be used with plated through-holes</p> <p>-PE = Pass-through Entry (For Bottom Entry specify -PE-BE)</p> <p>-HE = Horizontal Entry</p>	<p>-"XXX" = Polarized Position (-BE not available)</p>

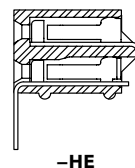
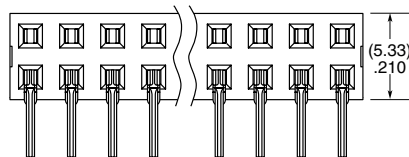
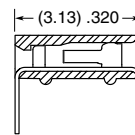
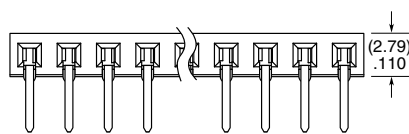
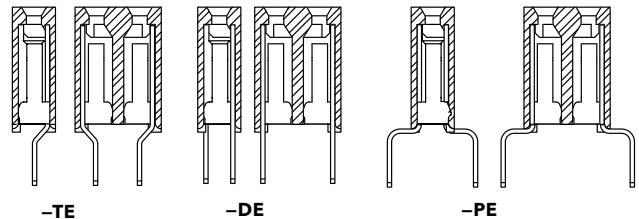
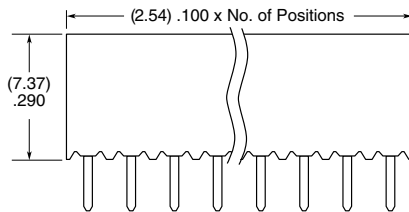
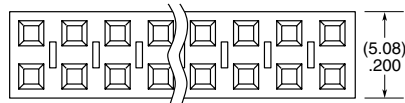
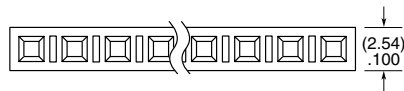

Note:

Some lengths, styles and options are non-standard, non-returnable.

BOTTOM MOUNT SOCKET STRIPS

(2.54 mm) .100" PITCH • BSW SERIES

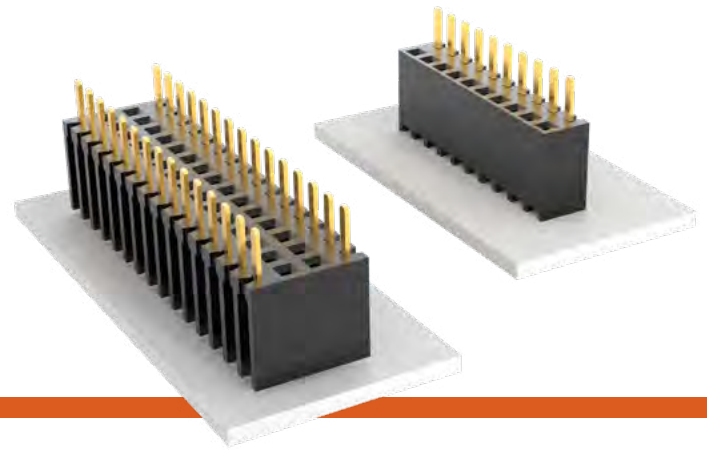

BSW

Mates:

TSW, MTSW, HTSW,
MTLW, TSM, EW, ZW,
HW, DW, PHT

FEATURES

- Bottom mount socket strips accept .025" SQ terminals.
- Ideal for soldering and plugging from the same side of the board.
- For low-profile connections and high temperature soldering.

SPECIFICATIONS

Insulator Material:

Black Thermoplastic

Insulation Resistance:

5000 MW min

Contact Material:

Phosphor Bronze

Plating:

Au or Sn over

50 μ" (1.27 μm) Ni

Operating Temp Range:

-55 °C to +125 °C with Gold

-55 °C to +105 °C with Tin

Withstanding Voltage:

1000 VRMS @ 60 Hz

Insertion Depth:

(3.68 mm) .145" to

(6.35 mm) .250"

PROCESSING

Lead-Free Solderable:

Wave only

ALSO AVAILABLE

Other Plating
(MOQ Required)

Note:

Some lengths, styles and options are non-standard, non-returnable.

BSW	1	NO. PINS PER ROW	LEAD STYLE	PLATING OPTION	ROW OPTION	OTHER OPTION
-----	---	------------------	------------	----------------	------------	--------------

02 thru 36

-04
= Standard Lead

-24
= Low Insertion Force

-L
= 10 μ" (0.25 μm) Gold contact, Matte Tin on tail

-G
= 20 μ" (0.51 μm) Gold contact, Gold Flash on tail

-T
= Matte Tin
(Not available with Low Insertion Force)

-S
= Single Row

-M
= Single Row More Plug Space

-D
= Double Row

-S
= Standoffs for single and double rows only (-S & -D only)

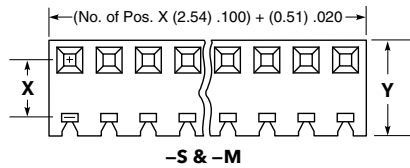

ROW OPTION	X	Y
-S	(2.54) .100	(5.08) .200
-M	(3.81) .150	(6.35) .250

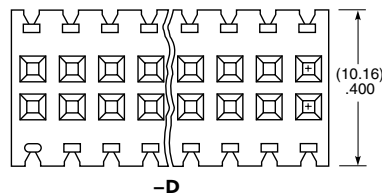

ROW OPTION	Z
-S*	(4.31) .170
-M	(3.43) .135
-D*	(4.32) .170

*Less (0.38 mm) .015" with standoffs

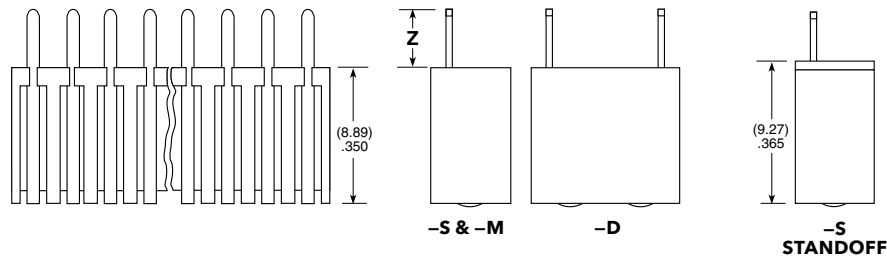

APPLICATIONS

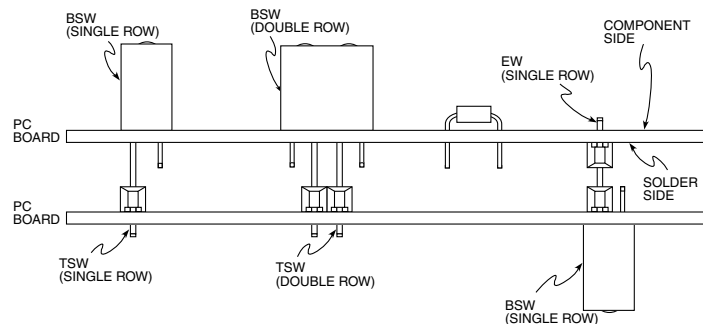

LOW-PROFILE SOCKET STRIPS

(2.54 mm) .100" PITCH • SLW/CES SERIES

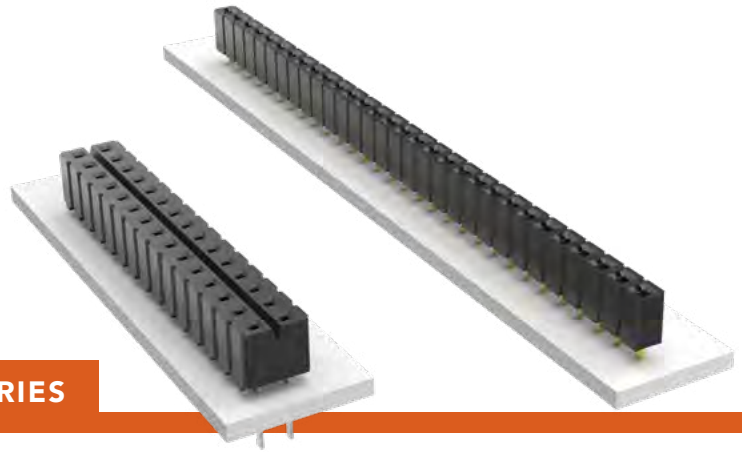

SLW

Mates:

TLW, TSW, MTLW, MTSW,
HW, EW, ZW, HTSW,
HMTSW, TSM

CES

Mates:

TLW, TSW, MTLW,
MTSW, HW, EW, ZW,
DW, HTSW, PHT, HMTSW

SLW	-	1	NO. PINS PER ROW	-	01	PLATING OPTION	-	ROW OPTION
-----	---	---	------------------	---	----	----------------	---	------------

01 thru 50



-F

= Gold flash on contact,
Matte Tin on tail

-S

= Single Row

-L

= 10 μ " (0.25 μ m) Gold on contact,
Matte Tin on tail

-D

= Double Row

-G

= 20 μ " (0.51 μ m) Gold on contact,
Gold flash on balance

-T

= Matte Tin

SPECIFICATIONS

Insulator Material:

Black G.F. Polyester

Contact Material:

Phosphor Bronze

Plating:

Au or Sn over
50 μ " (1.27 μ m) Ni

SLW Current Rating (SLW/TSW):

5.2 A per pin
(2 pins powered)

CES Current Rating (TSW/CES):

5.5 A per pin
(2 pins powered)

Voltage Rating:

SLW: 406 VAC
CES: 400 VAC

Operating Temp Range:

-55 $^{\circ}$ C to +125 $^{\circ}$ C with Gold
-55 $^{\circ}$ C to +105 $^{\circ}$ C with Tin

Insertion Depth:

SLW: (2.16 mm) .085" to
(2.92 mm) .115"
CES: (2.62 mm) .103" to
(4.06 mm) .160"

Lead-Free Solderable:

No, Lead Wave only

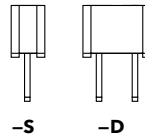
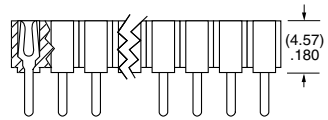
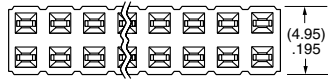
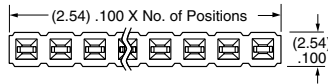

CES	-	1	NO. PINS PER ROW	-	LEAD STYLE	-	PLATING OPTION	-	ROW OPTION	-	RA OPTION
-----	---	---	------------------	---	------------	---	----------------	---	------------	---	-----------

01 thru 50

Specify
LEAD
STYLE
from
chart

-L

= 10 μ " (0.25 μ m)
Gold contact,
Matte Tin on tail

-S

= Single Row

-RA

= Right-angle
version
(Style -02 only
Single Row only)

-T

= Matte Tin

-D

= Double Row

PROCESSING

Lead-Free Solderable:

No, Lead Wave only

ALSO AVAILABLE

Other Plating
(MOQ Required)

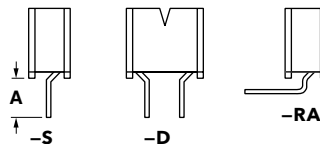
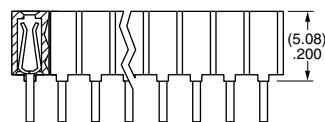
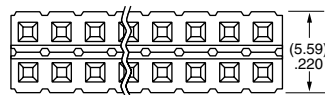
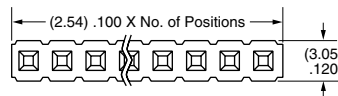

LEAD STYLE	A
-01	(3.25) .128
-02	(5.66) .223

Note:

Some lengths, styles and
options are non-standard,
non-returnable.

SHUNTS & JUMPERS



(2.54 mm) .100" PITCH • SNT/MNT/2SN/SNM/PK/JL SERIES

SNT/MNT

Mates:
TSW, HTSW, MTSW,
HMTSW, TLW, DW, EW,
ZW, HW, TSM, BST, PHT

2SN

Mates:
TMMH, TMM,
MTMM, MMT, TW,
LTMM, ZLTMM, TSH, EHT

SNM

Mates:
TMS, MTMS, DWM

SPECIFICATIONS

SNT

Insulator Material:
Glass Filled Polyester
Contact Material:
Phosphor Bronze
Current Rating (SNT/TSW):
4.3 A per pin
(1 pin powered per row)
Operating Temp Range:
-55 °C to +125 °C
Insertion Depth:
(4.32 mm) .170" minimum
Lead Size accepted:
(0.64 mm) .025" SQ

MNT

Same as SNT except:
Current Rating (MNT/TSM):
3.9 A per pin
(1 pin powered per row)
Working Voltage:
450 VAC

2SN

Same as SNT except:
Insertion Depth:
(2.29 mm) .090" minimum
Lead Size accepted:
(0.51 mm) .020" SQ

SNM

Same as SNT except:
Insertion Depth:
(3.43 mm) .135" minimum
Max Processing Temp:
Not recommended for IR/VP

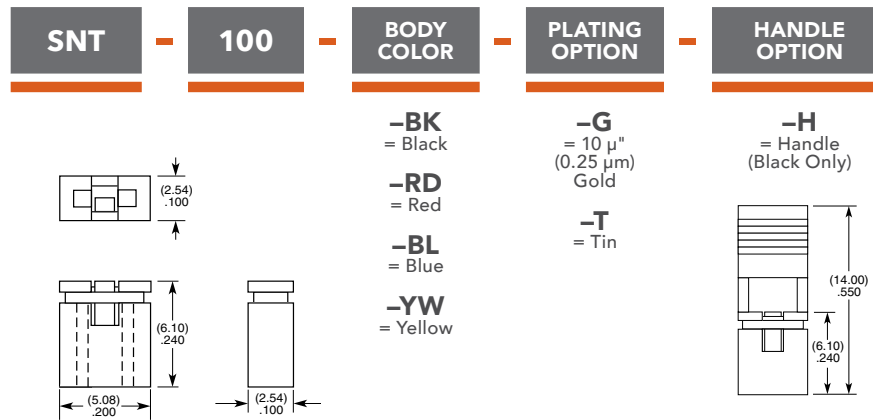

Note:
Other Gold plating options available.

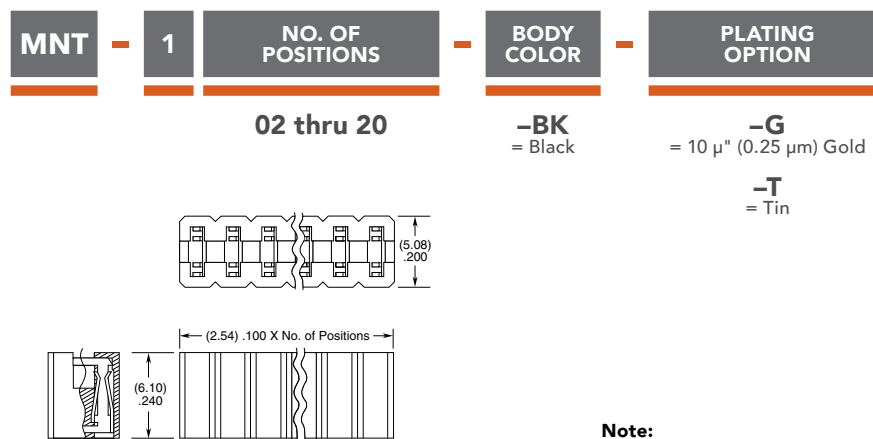

Note:
Some lengths, styles and options are non-standard, non-returnable.

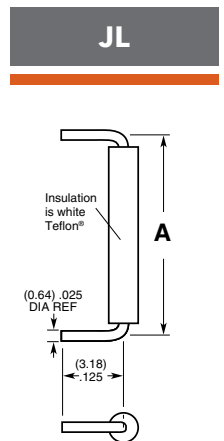
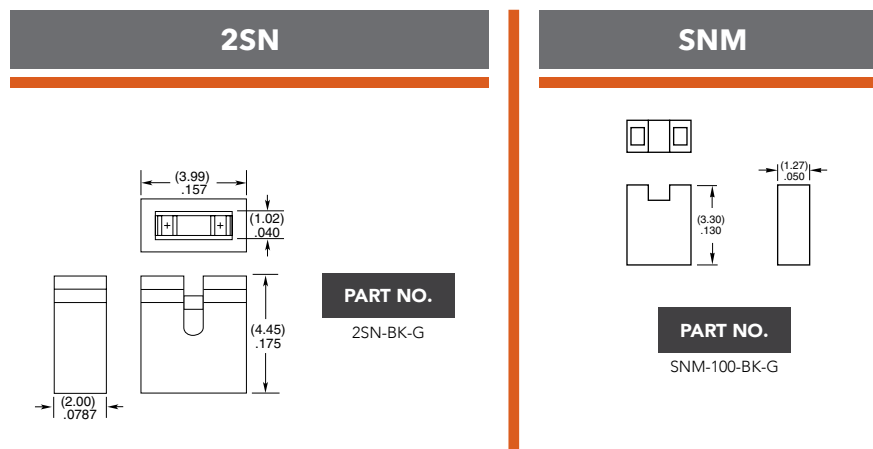

PART NO.	A
JL-100-25-T	(2.54) .100
JL-250-25-T	(6.35) .250
JL-400-25-T	(10.16) .400

Note:
For complete specifications see www.samtec.com?JL

PK

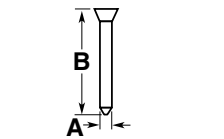

PART NO.	A	B
PK-01-06	(0.64) .025 SQ	(5.84) .230
PK-01-07	(0.51) .020 SQ	(3.18) .125

Insulator Material:
Natural Thermoplastic

Note:
Order per wheel.
6 pins per wheel.

IDC/FLAT FLEXIBLE CABLE SYSTEMS

TIGER EYE™ CONTACTS • MULTIPLE PITCHES • LOW PROFILE • SHROUDED EJECTOR TERMINALS

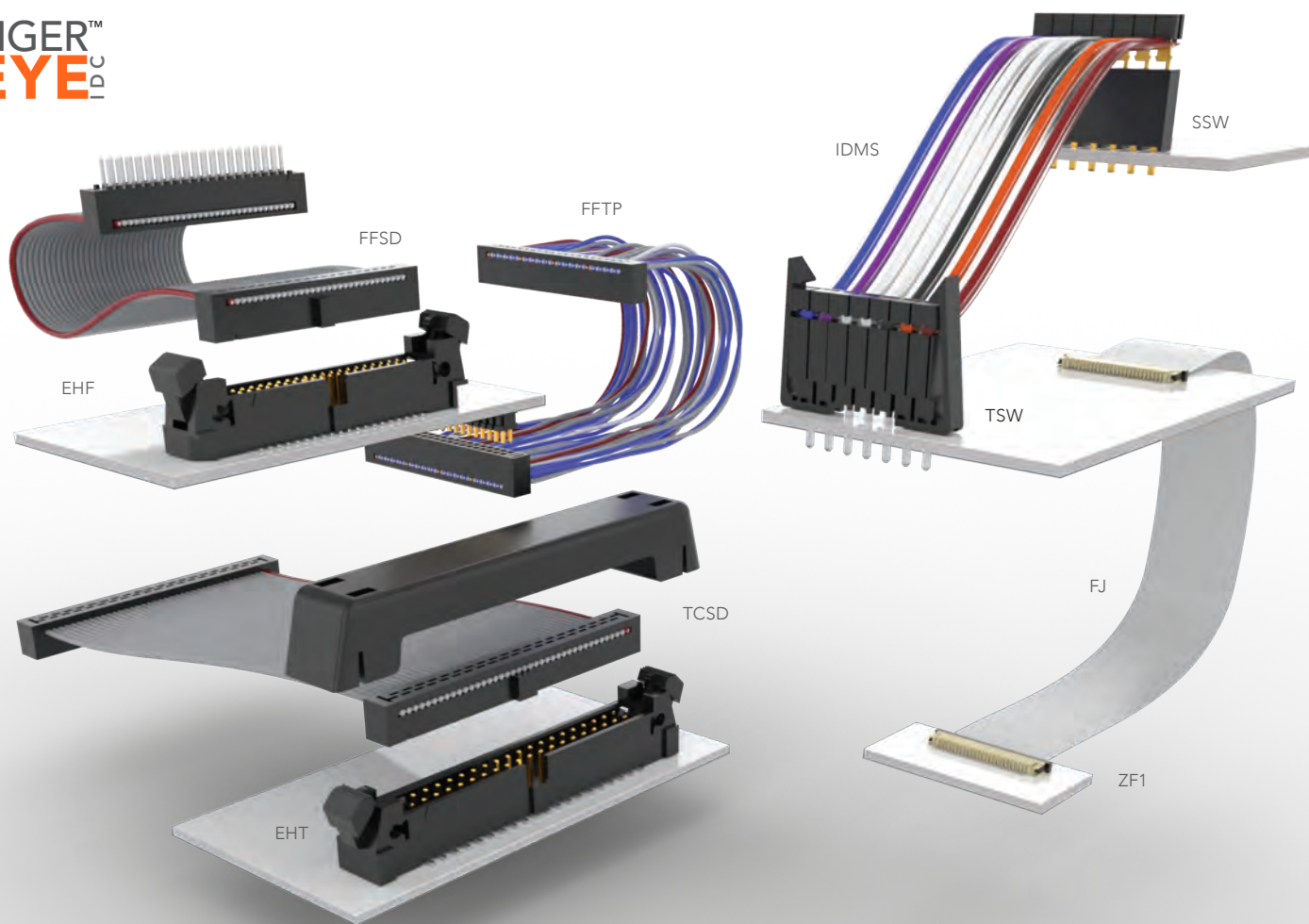

294-295

FLEX JUMPERS

0.50 mm (.0197") Pitch FFC Jumper & Sockets (FJH, ZF5S)	294
1.00 mm (.0394") Pitch FFC Jumper & Sockets (FJ, ZF1, FC1)	295

296-307

IDC ASSEMBLIES AND HEADERS

.100" (2.54 mm) Pitch (IDSX, IDMX, EJH, TST, HTST, ZST)	296-299
2.00 mm (.0787") Pitch (TCSD, TCMD, EHT, EC2, STMM, ZSTMM, ETMM)	300-303
.050" (1.27 mm) Pitch (FFSD, FFMD, FFTP, FMTP, EHF, SHF, ESHF)	304-307

FLAT FLEXIBLE CABLE (FFC) JUMPER & SOCKET

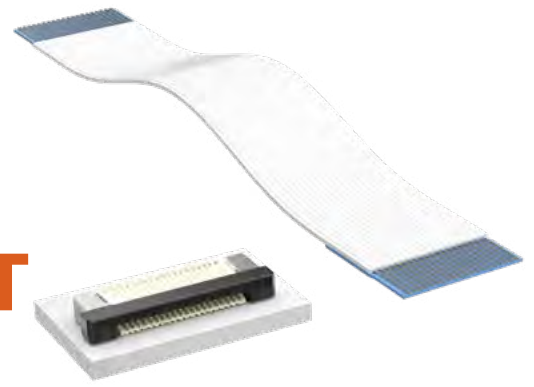

(0.50 mm) .0197" PITCH • FJH/ZF5S SERIES

FJH
Mates:
ZF5S

FJH	NO. OF POSITIONS	STYLE	LENGTH	STRIP LENGTH
-----	------------------	-------	--------	--------------

SPECIFICATIONS

Conductor:
Tin Plated Copper
Conductor Resistance:
1000 Ω/km max
Insulation Resistance:
10 M Ω/km min
(conductor-to-conductor)
Dielectric Test:
400 VAC during 1 minute
(conductor-to-conductor)
Temperature Rating:
-30 °C to +80 °C
Voltage Rating:
60 VAC

-10, -15,
-20, -25, -30,
-40, -43, -50
(Standard sizes)

-D
= Double End

-R
= Reversed End

Length in inches
-03.00
= (76.2 mm) 3.00"
-06.00
= (152.4 mm) 6.00"
-12.00
= (304.8 mm) 12.00"
-24.00
= (609.6 mm) 24.00"
(Standard Lengths)

-4
= (4.00 mm)
.157"

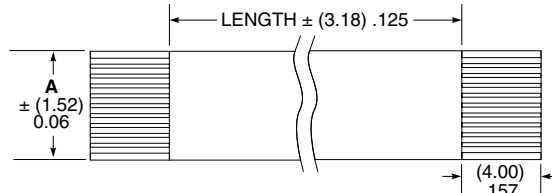

NO. OF POSTIONS	A
-10	(5.50) .217
-15	(8.00) .315
-20	(10.50) .413
-25	(13.00) .512
-30	(15.50) .610
-40	(20.50) .807
-43	(22.00) .866
-50	(25.50) 1.00

ALSO AVAILABLE

Other Platings
(MOQ Required)

Notes:
Stiffener color will be blue or black at Samtec's discretion. Some sizes, styles and options are non-standard, non-returnable.

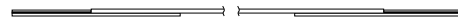

-D STYLE

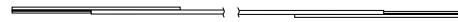

-R STYLE

ZF5S
Mates:
FJH

ZF5S	NO. OF POSITIONS	LEAD STYLE	PLATING OPTION	WT	OPTION
------	------------------	------------	----------------	----	--------

SPECIFICATIONS

Insulator Material:
Natural LCP
Contact Material:
Phosphor Bronze
Plating:
Sn over 50 μ" (1.27 μm) Ni
Weld Tab:
Phosphor Bronze
Operating Temp Range:
-55 °C to +105 °C
Current Rating:
1.8 A per pin
(1 pin powered)

-10, -15, -20, -25,
-30, -40, -43, -50
(Standard sizes)

-01
= Contact Bottom

-T
= Matte Tin

-WT
= Weld Tab

-K
= (3.00 mm)
.118" DIA
Polyimide Film
Pick &
Place Pad

-TR
= Tape &
Reel

-FR
= Full Reel
Tape & Reel
(must order
max. quantity
per reel;
contact
Samtec for
quantity breaks)

PROCESSING

Lead-Free Solderable:
Yes
SMT Lead Coplanarity:
(0.10 mm) .004" max (10-30)
(0.15 mm) .006" max (40-50)*
*(.004" stencil solution
may be available; contact
IPG@samtec.com)

Note:
Some sizes, styles and options are non-standard, non-returnable.

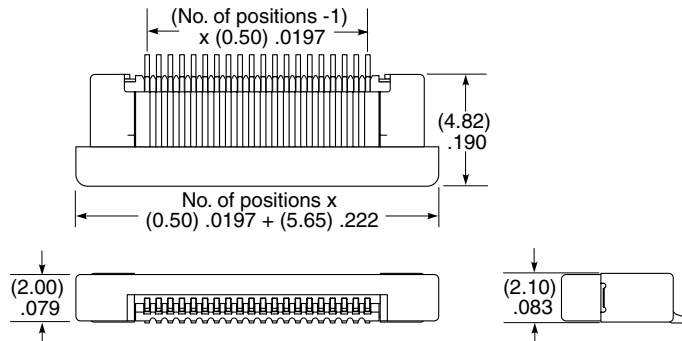

ALSO AVAILABLE

MOQ Required

Vertical
Contact top
Other positions

FLAT FLEXIBLE CABLE (FCC) JUMPER & SOCKET

(1.00 mm) .0394" PITCH • FJ/ZF1/FC1 SERIES

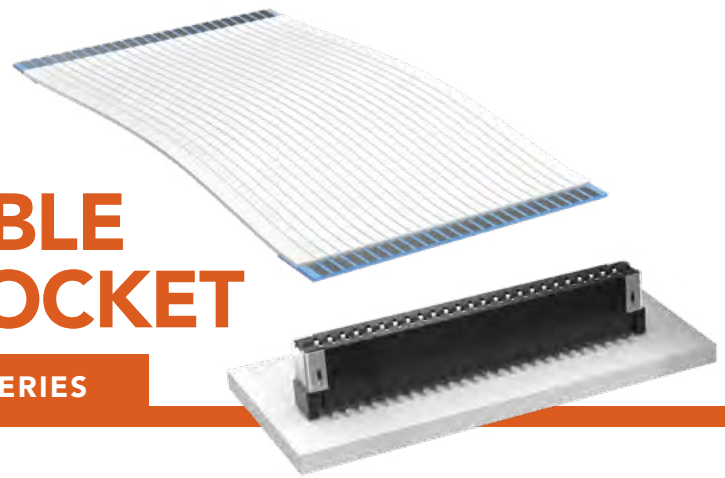

FJ

Mates:
FC1, ZF1

ZF1/FC1

Mates:
FJ

SPECIFICATIONS

FJ

Conductor:
Tin Plated Copper
Conductor Resistance:
300 Ω/km max
Insulation Resistance:
10 MΩ/km min
(conductor-to-conductor)
Dielectric Test:
400 VAC during 1 minute
(conductor-to-conductor)
Temperature Rating:
-30 °C to +80 °C
Voltage Rating:
300 VAC

ZF1

Insulator Material:
Liquid Crystal Polymer
Contact Material:
Phosphor Bronze
Plating:
Sn over 40 μ" (1.02 μm) Ni
Weld Tab: Phosphor Bronze
Operating Temp Range:
-55 °C to +105 °C

FC1

Insulator Material:
Liquid Crystal Polymer
Contact Material:
Phosphor Bronze
Plating:
Sn over 50 μ" (1.27 μm) Ni
Operating Temp Range:
-55 °C to +105 °C
Max Cycles:
25 with FJ

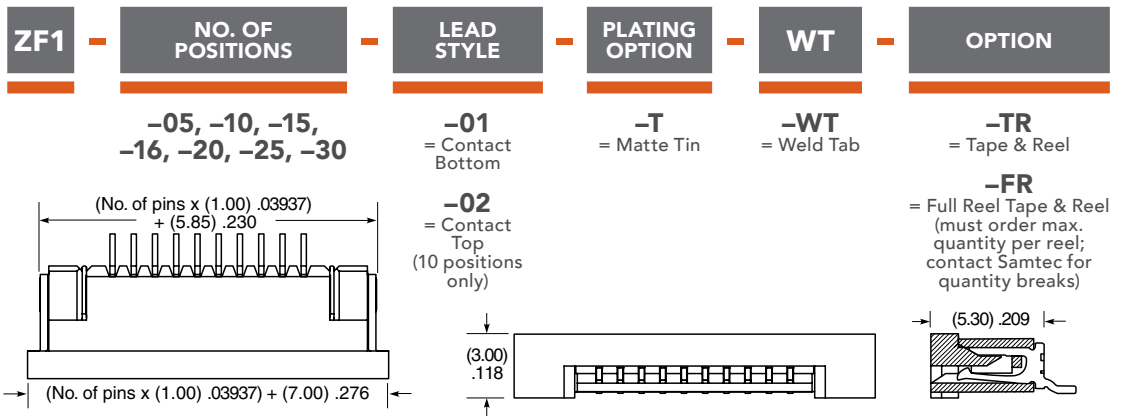
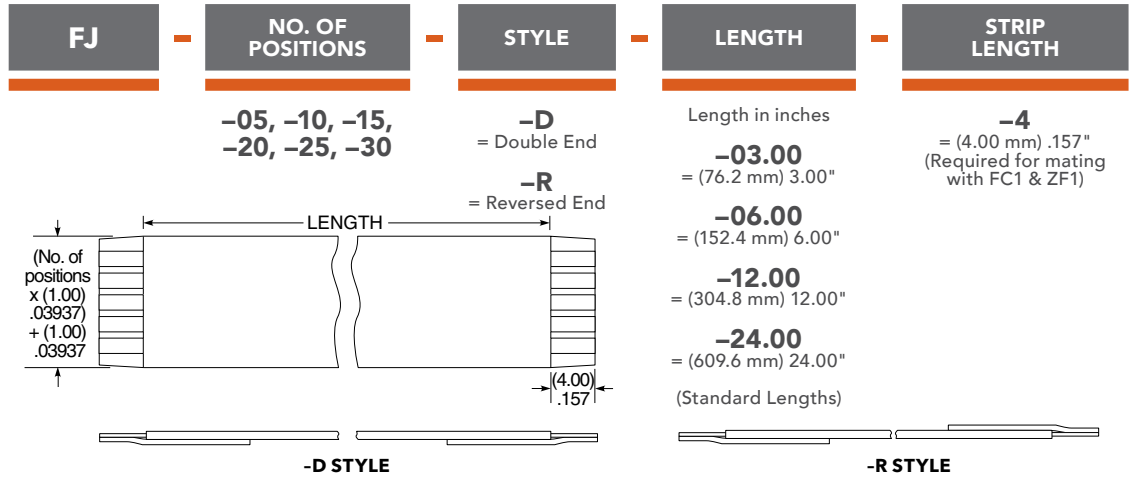

PROCESSING

ZF1/FC1

Lead-Free Solderable:
Yes
SMT Lead Coplanarity:
(0.10 mm) .004" max

Notes:
FJ Stiffener color will be blue or black at Samtec's discretion.

Some sizes, styles and options are non-standard, non-returnable.

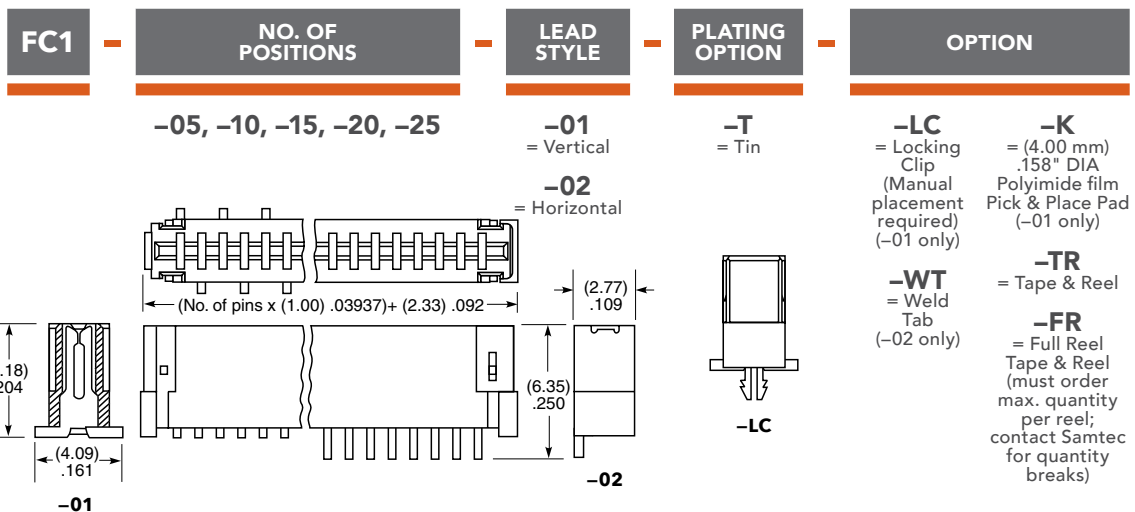

SLIM BODY FLAT RIBBON IDC CABLES



(2.54 mm) .100" PITCH • IDSS/IDSD/IDMS/IDMD SERIES

IDSS/IDMS/IDMD

Mates:

TSW, MTSW, TSM, EJH,
PHT, HMTSW, HTSW,
HW, DW, EW, ZW, MTLW

IDSD

Mates:

TST, HTST, ZST, BST, EJH

SERIES	ROW OPTION	NO. PINS PER ROW
IDM = Standard Tail Male Plug	S = Single	-02 thru -32 = IDMS/IDMD
IDS = Socket	D = Double (Color coded cable Not available for 31 thru 36 pins/row. See -G option.)	-02 thru -36 = IDSS/IDSD

SPECIFICATIONS

Insulator Material:

Black Glass Filled Polyester

Contact (IDSS/IDSD):

BeCu

Terminal (IDMS/IDMD):

Phosphor Bronze

Plating:

Au over 50 μ " (1.27 μ m) Ni or
Sn over 100 μ " (2.54 μ m) Cu or
50 μ " (1.27 μ m) Ni

Wire:

28 AWG 7/36 stranded
Tinned Copper

Current Rating (IDSD/TST):

3.4 A per pin
(2 pins powered)

Current Rating (IDMD):

3 A per pin
(2 pins powered)

Temperature Range:

-20 °C to +105 °C
(Rainbow Cable)
-40 °C to +105 °C
(Gray Cable)

Voltage Rating:

425 VAC/600 VDC

Lead Size Range:

(0.56 mm) .022" SQ to
(0.71 mm) .028" SQ

Lead Insertion Depth:

(5.59 mm) .220" to
(6.22 mm) .245"

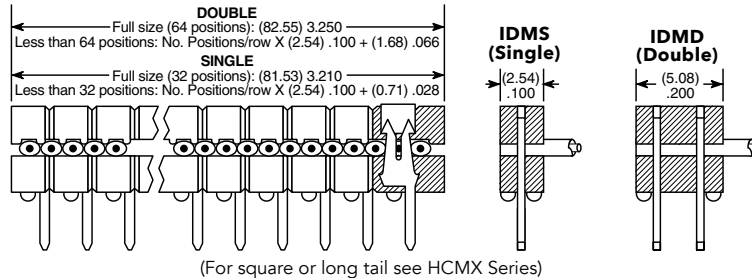

IDMX shown

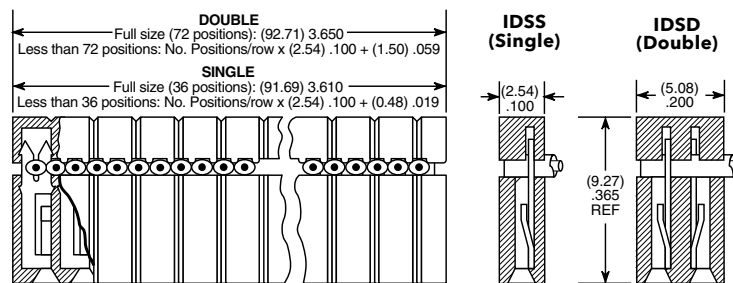

IDSX shown

ALSO AVAILABLE

Molded-To-Position IDC Assemblies

Low Profile

Skinny side locks

Dual beam contacts

Single and double row

(6.35mm) .025" square and
(5.84mm) .230" length tail available

Visit samtec.com?HCSD, samtec.com?HCSS,
samtec.com?HCMD or samtec.com?HCMS
for more detailed information.

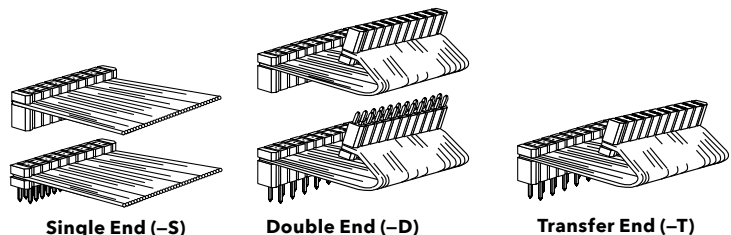
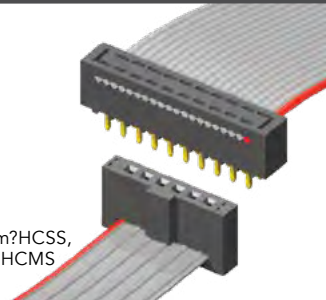

Note:

This Series is non-standard,
non-returnable.



END ASSEMBLY

-S
= Single End
(Socket or Male Plug on one end)

-D
= Double End
(Socket or Male Plug on each end)

-T
= Transfer End
(Male Plug on one end with socket on other.
Begin part number with IDM)

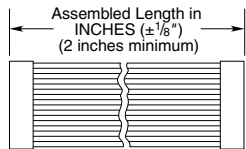

Assembled Length (-"XX.XX")

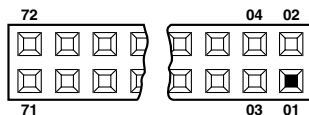

Polarized (-P "XX")

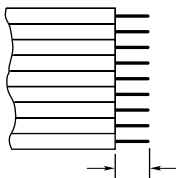

-ST8	1/8" (3.18)
-ST4	1/4" (6.35)
-ST2	1/2" (12.70)
-ST3	3/8" (9.53)

Stripped & Tinned (-ST "X")

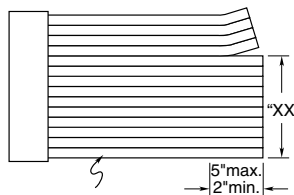

Breakout starts with Number 1 lead indicated by brown wire or red stripe.
Shown on top side.

Breakout (-B "X")

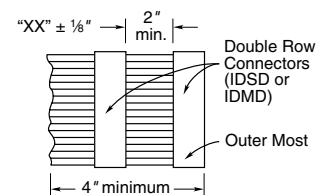

Daisy Chain Single (-S "XX")

ASSEMBLED LENGTH

-"XX.XX"
= Assembled Length

OPTION

-T
= Tin Plating
(Both Ends)

-C
= Tin IDM,
10 μ " (0.25 μ m) Gold IDS
(-T End Assembly Required)

-A
= Tin IDS,
10 μ " (0.25 μ m) Gold IDM
(-T End Assembly Required)

-P "XX"
= Polarized
Specify "XX" as position.
For Double the same position will be polarized on both ends.
(Not available on IDM unless transfer, then only the socket is polarized.)

-G
= Gray Cable
Specify -G for Gray cable.
Gray cable has one red edge.
IDSS and IDMS uses (2.54 mm) .100" centerline cable.
IDSD and IDMD uses (1.27 mm) .050" centerline cable.
Cable is 28 AWG 7/36 copper wire.
Standard cable is same as above except color

-ST "X"
= Stripped & Tinned
(Specify Suffix from table)
(All dimensions are $\pm 1/16"$ (1.59 mm))
(Not available in 28 positions and higher)

-B "XX"
= Breakout
(Specify "XX" as number of conductors to be broken out)
(Breakout starts with Number 1 lead indicated by brown wire or red stripe.
Shown on top side)

-RW
= Reversed Wiring
(#1 wire opposite position #1)

-S "XX"
= Daisy Chain, Single
(When mating double row connector with two single row connectors, the outer most single will be connected to Conductor #1 and the inside single to Conductor #2)

-D "XX"
= Daisy Chain, Double

-W "XX"
= Wiring Reverse Daisy Chain, Single
(Same as -S "XX" except outer strip connected to Conductor #2 and inside strip connected to Conductor #1)

-R
= Reverse

-M
= Middle Reverse
(Requires -SXX, -WXX or -DXX)

-O
= Outside Reverse
(Requires -SXX, -WXX or -DXX)

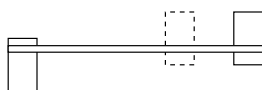

Reverse (-R)

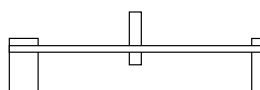

Middle Reverse (-M)

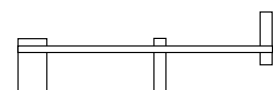

Outside Reverse (-O)

SHROUDED IDC EJECTOR HEADERS

(2.54 mm) .100" PITCH • EJH SERIES

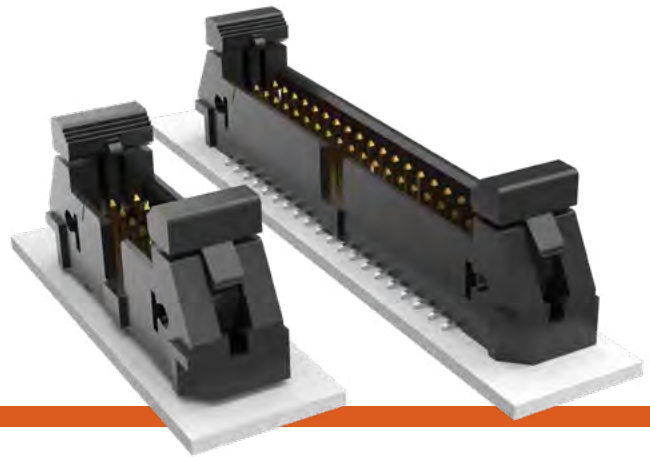

EJH

Mates:

IDSD (EJH-01 Required),
HCSD (EJH-02 Required)

SPECIFICATIONS

Insulator Material:

-01=Black LCP
-02=Natural LCP

Terminal Material:

Phosphor Bronze

Plating:

Sn or Au over 50 μ" (1.27 μm) Ni

Operating Temp Range:

-55 °C to +125 °C

PROCESSING

Lead-Free Solderable:

Yes

SMT Lead Coplanarity:

(0.10 mm) .004" max

ALSO AVAILABLE

MOQ Required

Other sizes

Other platings

EJH	1	NO. PINS PER ROW	LEAD STYLE	PLATING OPTION	D	TAIL OPTION	OTHER OPTION
-----	---	------------------	------------	----------------	---	-------------	--------------

05, 07,
08, 10,
13, 15,
17, 20, 25
(Standard sizes)

-01
= Standard
(Mates to IDSD)

-02
= Extended
(Mates to HCSD)

-F
= Gold flash
on post,
Matte Tin on
tail

-L
= 10 μ"
(0.25 μm)
Gold on post,
Matte Tin on
tail

-SM
= Surface
Mount

-TH
= Through-hole

-RA
= Right-angle

-“XX”
= Polarized
Position

-LC
= Locking Clip
(-SM only)
(Manual
placement
required)

-K
= .475"
(12.00 mm)
DIA
Polyimide
Film Pick &
Place Pad
(-SM only)

-P
= Pick &
Place Pad
(-SM only)

-TR
= Tape &
Reel
(-SM only)
(25 position
not available)

-FR
= Full Reel
Tape & Reel
(must order
max. quantity
per reel;
contact
Samtec for
quantity
breaks)
(-SM only)
(25 position
not available)

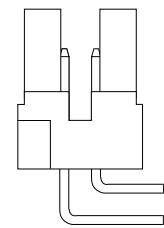
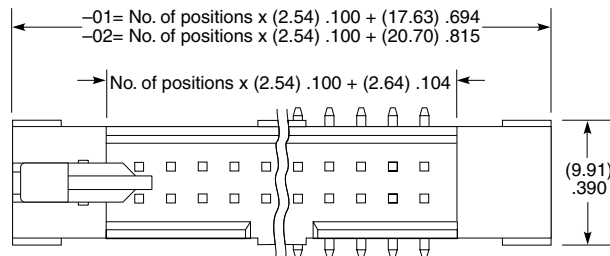

-RA OPTION

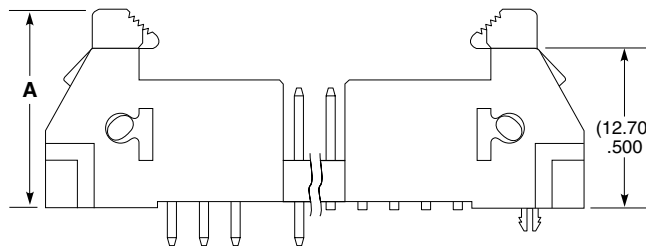

-LC OPTION

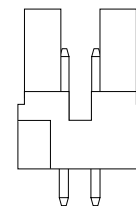

-SM OPTION

(Latch removed for clarity)

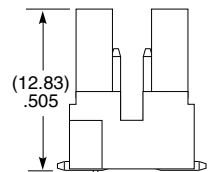

-SM OPTION

LEAD STYLE	A
-01	(16.88) .665
-02	(17.39) .685

Note:

Some lengths, styles and options are non-standard, non-returnable.

FLEX STACK

SHROUDED .025" SQ POST IDC HEADERS

(2.54 mm) .100" PITCH • TST/HTST/ZST SERIES

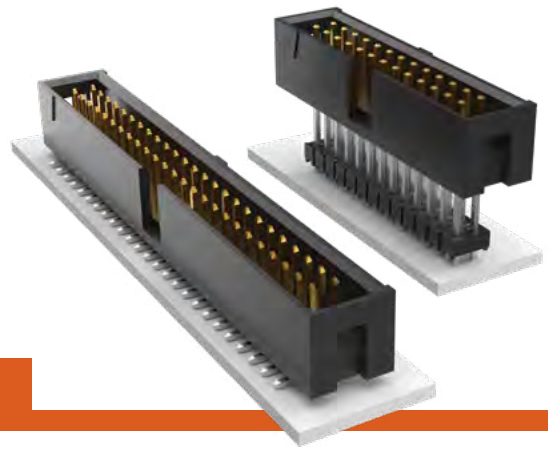

TST/HTST/ZST

Mates:
IDSD, HCSD

SPECIFICATIONS

Insulator Material:

TST, ZST=Black Glass Filled Polyester
HTST=Natural LCP

Insulation Resistance:

5000 MΩ min

Terminal Material:

Phosphor Bronze

Plating:

Au or Sn over

50 μ" (1.27 μm) Ni

Current Rating (IDSD/TST):

3.4 A per pin

(2 pins powered)

Operating Temp Range:

-55 °C to +125 °C with Gold

-55 °C to +105 °C with Tin

Voltage Rating:

425 VAC/600 VDC

PROCESSING

Lead-Free Solderable:

HTST=Yes

TST, ZST= No, Lead Wave only

SMT Lead Coplanarity:

(0.10 mm) .004" max (05-15)

(0.15 mm) .006" max (17-36)*

*(.004" stencil solution

may be available; contact

ipg@samtec.com)

SERIES	1	NO. PINS PER ROW	LEAD STYLE	PLATING OPTION	ROW OPTION	OTHER OPTION
--------	---	------------------	------------	----------------	------------	--------------

TST
= Cable Strip

HTST
= High Temp Cable Strip

05, 07, 08, 10, 12, 13, 15, 17, 20, 25, 32, 36
(Standard sizes)

Specify LEAD STYLE from chart

-F
= Gold flash on post, Matte Tin on tail
(Not available on -DV)

-L
= 10 μ" (0.25 μm) Gold on post, Matte Tin on tail

-T
= Matte Tin

-D
= Double Row Through-hole (lead style -01, -02 & -03 only)

-DV
= Double Row Surface Mount (lead style -01 only) (HTST only)

-D-RA
= Double Row Right-angle (lead style -04 & -05 only)

Surface Mount (lead style -01 only) (HTST only)

-P
= Pick & Place Pad

-TR
= Tape & Reel

-FR
= Full Reel Tape & Reel (must order max. quantity per reel; contact Samtec for quantity breaks)

LEAD STYLE	THROUGH-HOLE (A)
-01	(2.92) .115
-02	(4.19) .165
-03	(14.35) .565

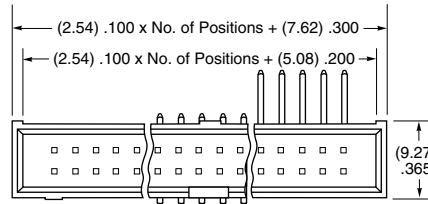

-D -DV -D-RA

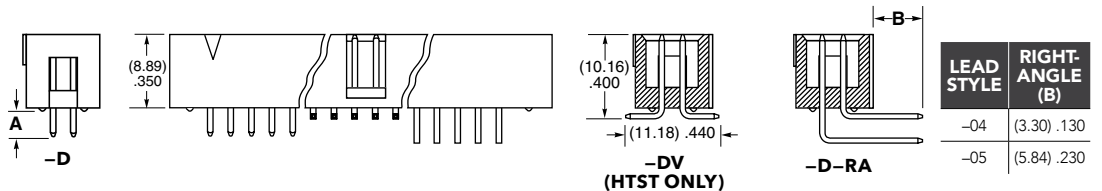

ZST	1	NO. PINS PER ROW	LEAD STYLE	PLATING OPTION	D	BODY HEIGHT
-----	---	------------------	------------	----------------	---	-------------

05, 07, 08, 10, 12, 13, 15, 17, 20, 25, 32, 36
(Standard sizes)

Specify LEAD STYLE from chart

-F
= Gold flash on post, Matte Tin on tail

-L
= 10 μ" (0.25 μm) Gold on post, Matte Tin on tail

-T
= Matte Tin

-"XXXX"
= Body Height

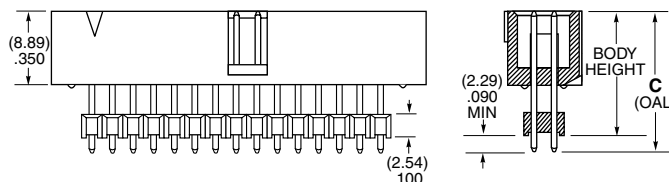
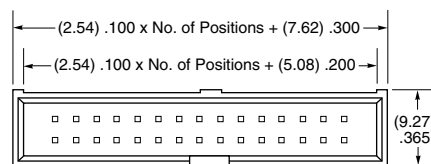

LEAD STYLE	C (OAL)	MAX BODY HEIGHT
-01	(16.00) .630	(13.72) .540
-02	(18.54) .730	(16.26) .640
-03	(21.08) .830	(18.80) .740
-04	(23.62) .930	(21.34) .840
-05	(26.16) 1.030	(23.88) .940
-06	(28.70) 1.130	(26.42) 1.040
-07	(31.24) 1.230	(28.96) 1.140
-08	(33.78) 1.330	(31.50) 1.240
-09	(36.32) 1.430	34.04) 1.340

Note:

For added mechanical stability, Samtec recommends mechanical board spacers be used in applications with gold or selective gold plated connectors. Contact ipg@samtec.com for more information.

ALSO AVAILABLE MOQ Required

Other platings & sizes

Alignment Pins

Single Row

Locking Leads

Polarized

Note:

Some lengths, styles and options are non-standard, non-returnable. ZST is non-standard, non-returnable.

TIGER EYE™ IDC SOCKET CABLE

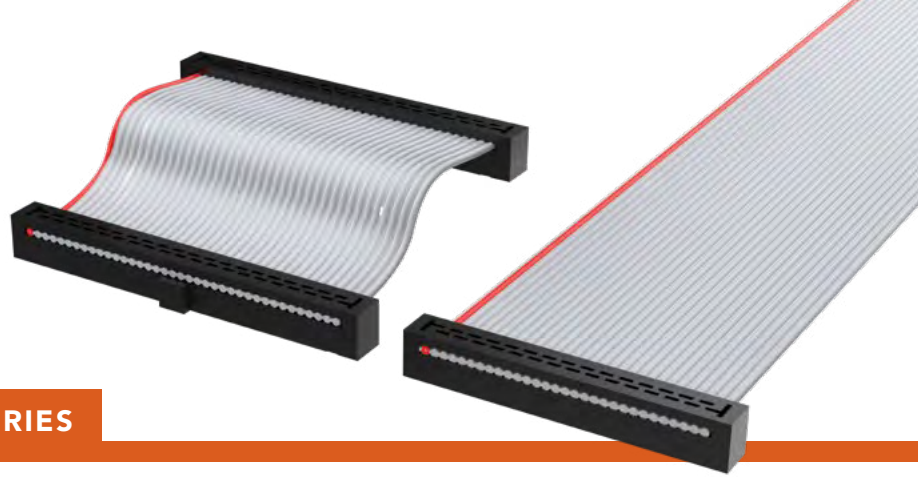

(2.00 mm) .0787" PITCH • TCSD SERIES

TCSD

Mates:
TMM, TMMH, STMM,
MMT, TW, MTMM, EHT,
ETMM (-SR), ZSTMM

SPECIFICATIONS

Insulator Material:
Black Glass Filled Polyester
Contact:
BeCu
Plating:
Au or Sn over
50 μ" (1.27 μm) Ni
Wire:
28 AWG 7/36 Stranded,
Tinned, Copper with
Gray PVC Insulator
**Current Rating
(TCSD/STMM):**
2.8 A per pin
(2 pins powered)
Operating Temp Range:
-40 °C to +105 °C
Lead Size Accepted:
(0.48 mm) .019" to
(0.53 mm) .021"
Insertion Depth:
(2.87 mm) .113" to
(3.17 mm) .125"

ALSO AVAILABLE
MOQ Required

Other sizes
Other platings

POLARIZING KEY

Specify PK-01-07 for polarizing key
(Available in wheels of six each).
Also polarizes SMM Series
socket strips.

SERIES	NO. PINS PER ROW	END OPTION	OVERALL LENGTH	01	PLATING OPTION	N	OTHER OPTION
--------	------------------	------------	----------------	----	----------------	---	--------------

TCSD = Socket Strip	-04, -05, -07, -08, -10, -12, -13, -15, -17, -20, -22, -25 (Standard sizes)	-S = Single End -D = Double End	-"XX.XX" = Assembled Length	01	Leave blank for standard plating 30 μ" (0.76 μm) Gold on contact area -F = Gold flash on contact	-N = Notch Polarization	-P "XX" = Position Polarization (Specify "XX" as position number. Same position will be polarized on both ends) -B "XX" = Breakout (Specify "XX" as number of conductors to be broken out)
-------------------------------	---	--	---------------------------------------	-----------	---	-----------------------------------	---

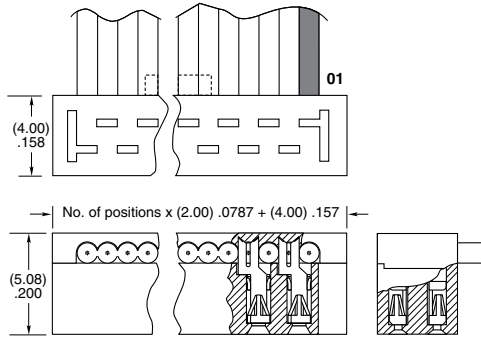

-RW
= Reverse Wiring (Blue or black wire opposite position #1)
-D "XX"
= Daisy Chain
-SR
= Strain Relief (Not available with -O, -M, -R, -DXX or -BXX)

-R
= Reverse
-M
= Middle Reverse (Requires -DXX)
-O
= Outside Reverse (Requires -DXX)

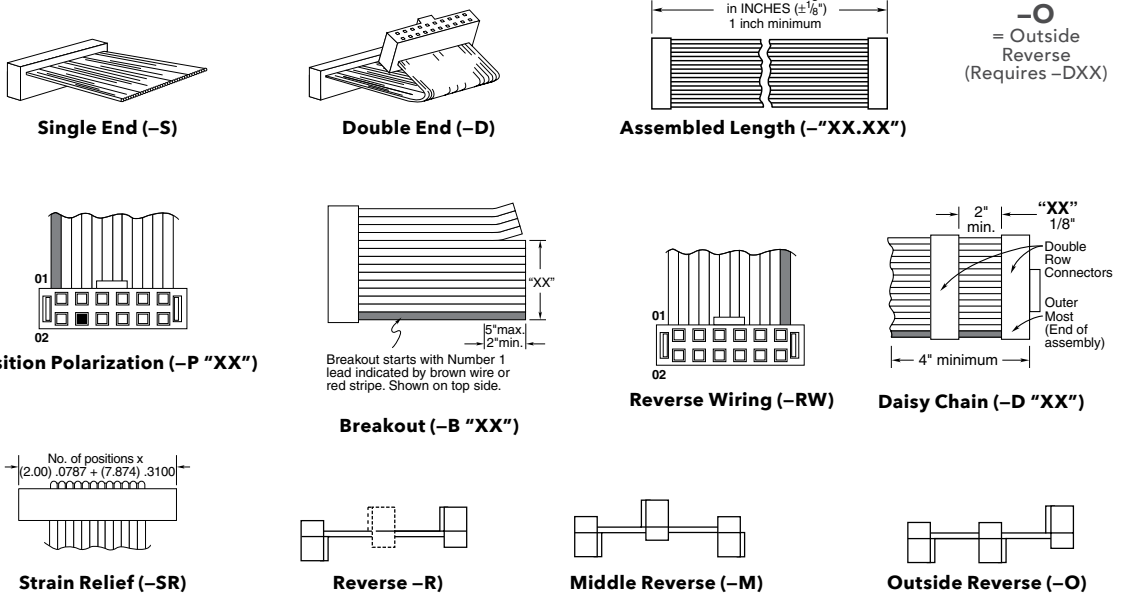

Note:
TCSD Series assemblies are non-standard, non-returnable.

HIGH-RELIABILITY IDC HEADER CABLE

(2.00 mm) .0787" PITCH • TCMD SERIES

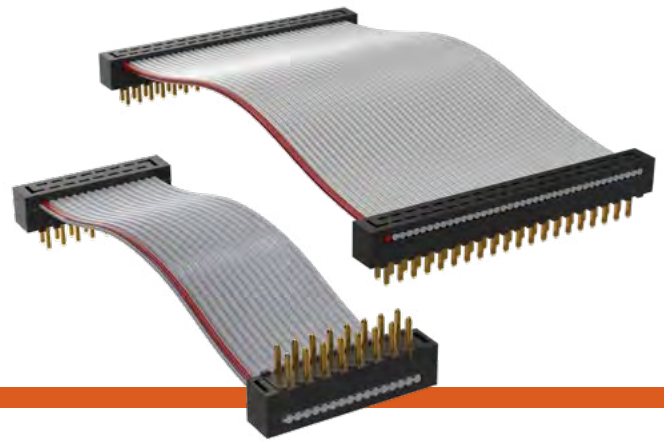

TCMD

Mates:

SMM*, MMS*, ESQT,
PTF, SQT, SQW, TLE

SPECIFICATIONS

Insulator Material:

Black Glass Filled Polyester

Terminal:

Phosphor Bronze

Plating:

Au or Sn over
50 μ" (1.27 μm) Ni

Wire:

28 AWG 7/36 Stranded, Tinned,
Copper with
Gray PVC Insulator

Current Rating:

2.6 A per pin
(2 pins powered)

Operating Temp Range:

-40 °C to +105 °C

ALSO AVAILABLE

Other sizes

(MOQ Required)



Single End (-S)

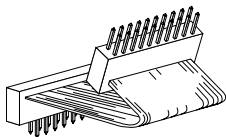

Double End (-D)

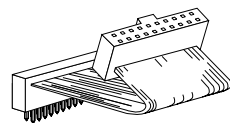

Transfer End (-T)

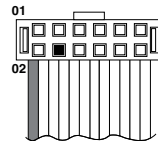

Position Polarization (-P "XX")

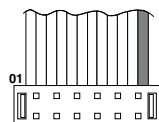

Reverse Wiring (-RW)

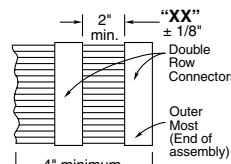

Daisy Chain (-D "XX")

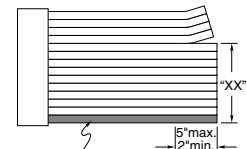

Breakout starts with Number 1 lead indicated by brown wire or red stripe. Shown on top side.

Breakout (-B "XX")

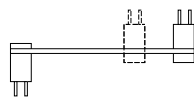

Reverse (-R)

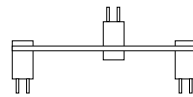

Middle Reverse (-M)

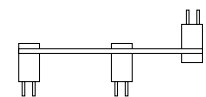

Outside Reverse (-O)

SERIES	NO. PINS PER ROW	END OPTION	OVERALL LENGTH	01	TRANSFER OPTION	OTHER OPTION
--------	------------------	------------	----------------	----	-----------------	--------------

TCMD
= Terminal Strip

-04, -05, -07
-08, -10, -12,
-13, -15, -17,
-20, -22, -25
(Standard sizes)

-S
= Single End

-D
= Double End

-T
= Transfer End

-"XX.XX"
= Assembled Length

Leave blank for
-S and -D
End Options.
For -T End
Option Specify
"-N"
(Socket has notch
polarization)

-P "XX"
= Position
Polarization
(Specify "XX" as
position number.
Requires Transfer
End. Only Socket
is polarized.)

-B "XX"
= Breakout
(Specify "XX"
as number of
conductors to
be broken out)

-RW
= Reverse Wiring
(Blue or black
wire opposite
position #1)

-D "XX"
= Daisy Chain

-SR
= Strain Relief
(Not available
with -O, -M, -R,
-DXX or -BXX)

-R
= Reverse

-M
= Middle Reverse
(Requires -DXX)

-O
= Outside Reverse
(Requires -DXX)

*Note:

Standard TCMD callout will not mate with SMM, MMS. Must use gold plated callouts. (See drawing on web.)
When mated with a socket, Wire 1 mates with Pin 2; Wire 2 mates with Pin 1, etc.

Note:

TCMD Series assemblies are non-standard, non-returnable.

SHROUDED IDC HEADERS

(2.00 mm) .0787" PITCH • ETMM/EHT SERIES

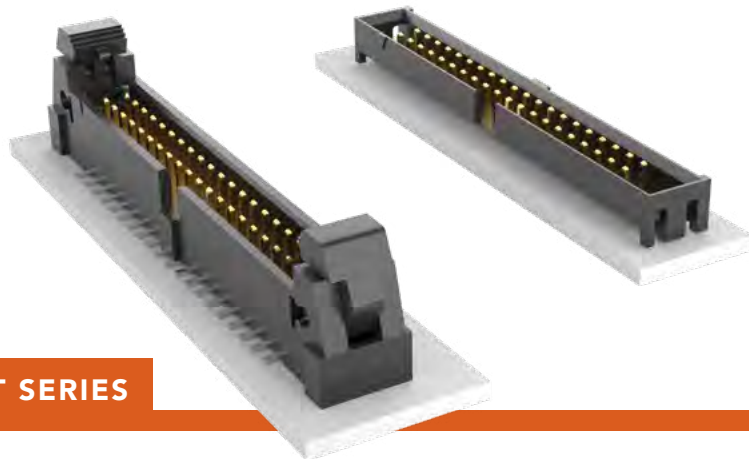

ETMM

Mates:
TCSD, TCMD

EHT

Mates:
TCSD

SPECIFICATIONS

Insulator Material:
Black Liquid Crystal Polymer
Terminal Material:
Phosphor Bronze
Plating:
Sn or Au over
50 μ" (1.27 μm) Ni
Operating Temp Range:
-55 °C to +125 °C

PROCESSING

Lead-Free Solderable:
Yes
SMT Lead Coplanarity:
EHT = (0.10 mm) .004" max
ETMM = (0.13 mm) .005" max*
*(.004" stencil solution may be available; contact IPG@samtec.com)

TYPE STRIP	1	NO. PINS PER ROW	02	PLATING OPTION	D	TAIL OPTION	OTHER OPTION
ETMM		05, 08, 10, 12, 13, 15, 17, 20, 22, 25 (Standard sizes)		-F = Gold Flash on post, Matte Tin on tail -L = 10 μ" (0.25 μm) Gold on post, Matte Tin on tail		-TH = Through-hole -RA = Right-angle -SM = Surface Mount	-“XX” = Polarized Position -LC = Locking Clip (N/A with -RA) (Manual placement required) -K = (7.50 mm) .295" DIA Polyimide Film Pick & Place Pad (-SM only) -TR = Tape & Reel (-SM only) -FR = Full Reel Tape & Reel (must order max. quantity per reel; contact Samtec for quantity breaks) (-SM only)

EJECTOR HEADER CAP

The EC2 locks TCSD cable to EHT header. See samtec.com?EC2 for information about the header cap.

EHT	1	NO. PINS PER ROW	01	PLATING OPTION	D	TAIL OPTION	OTHER OPTION
		05, 08, 10, 12, 13, 15, 17, 20, 22, 25		-F = Gold flash on post, Matte Tin on tail -L = 10 μ" (0.25 μm) Gold on post, Matte Tin on tail		Leave blank for Through-hole -RA = Right-angle -SM = Surface Mount	-“XX” = Polarized Position -SR = Strain Relief (Leave Blank for no strain relief) -LC = Locking Clip (-SM only) (Manual placement required) -K = (7.50 mm) .295" DIA Polyimide Film Pick & Place Pad (-SM only) -P = Pick & Place Pad (-SM only) -TR = Tape & Reel (-SM only) -FR = Full Reel Tape & Reel (must order max. quantity per reel; contact Samtec for quantity breaks) (-SM only)

Note:
Some lengths, styles and options are non-standard, non-returnable.

FLEX STACK

SHROUDED IDC HEADER & STACKER

(2.00 mm) .0787" PITCH • STMM/ZSTMM SERIES

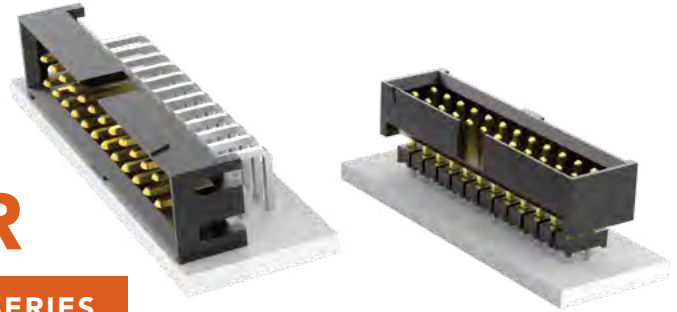

STMM/ZSTMM

Mates:
TCSD (except -SR)

SPECIFICATIONS

Insulator Material:
Black Liquid Crystal Polymer
Terminal Material:
Phosphor Bronze
Plating:
Sn or Au over
50 μ" (1.27 μm) Ni
Operating Temp Range:
-55 °C to +105 °C with Tin;
-55 °C to +125 °C with Gold

PROCESSING

Lead-Free Solderable:
Yes
SMT Lead Coplanarity:
(0.10 mm) .004" max

STMM	1	NO. PINS PER ROW	02	PLATING OPTION	D	TAIL OPTION	OTHER OPTION
		04, 05, 06, 07, 08, 10, 12, 13, 14, 15, 17, 20, 22, 25 (Standard sizes)		-F = Gold flash on post, Matte Tin on tail -L = 10 μ" (0.25 μm) Gold on post, Matte Tin on tail -T = Matte Tin		Leave blank for Through-hole -RA = Right-angle -SM = Surface Mount	- "XX" = Polarized Position -LC = Locking Clip (-SM only) (Manual placement required) -K = (7.50 mm) .295" DIA Film Pick & Place Pad (-SM only) -TR = Tape & Reel (-SM only) -FR = Full Reel Tape & Reel (must order max. quantity per reel; contact Samtec for quantity breaks) (-SM only)
		T/H -SM -RA		-SM		-RA	

ZSTMM	1	NO. PINS PER ROW	LEAD STYLE	PLATING OPTION	D	BODY HEIGHT	OTHER OPTION
		04, 05, 06, 07, 08, 10, 12, 13, 14, 15, 17, 20, 22, 25 (Standard sizes)	Specify LEAD STYLE from chart	-F = Gold flash on post, Matte Tin on tail -L = 10 μ" (0.25 μm) Gold on post, Matte Tin on tail -T = Matte Tin		- "XXX" = Body Height	- "XX" = Polarized Position

LEAD STYLE	A (OAL)	MAX BODY HEIGHT
-75	(9.58) 0.377	(7.42) 0.292
-62	(10.08) 0.397	(7.92) 0.312
-65	(10.49) 0.413	(8.33) 0.328
-73	(12.09) 0.476	(9.93) 0.391
-63	(14.10) 0.555	(11.94) 0.470
-66	(15.09) 0.594	(12.93) 0.509
-69	(15.60) 0.614	(13.44) 0.529
-74	(17.09) 0.673	(14.94) 0.588
-70	(17.60) 0.693	(15.44) 0.608
-71	(21.08) 0.830	(18.92) 0.745
-72	(21.62) 0.851	(19.46) 0.766

ALSO AVAILABLE

MOQ Required

Other sizes
Other platings

Notes:
For added mechanical stability, Samtec recommends mechanical board spacers be used in applications with gold or selective gold plated connectors. Contact ipg@samtec.com for more information.

This Series is non-standard, non-returnable.

TIGER EYE™ FLAT IDC WIRE CABLES

(1.27 mm) .050" PITCH • FFSD SERIES

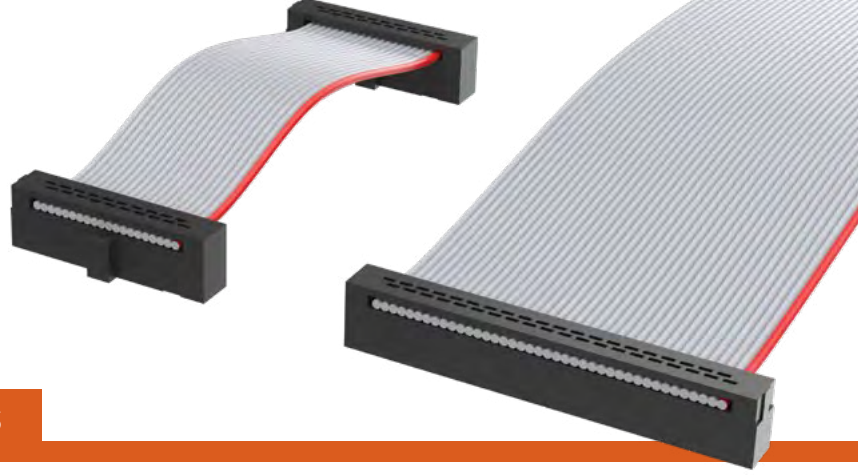

FFSD

Mates:

FTS, FTSH, EHF,
SHF, ESHF

SPECIFICATIONS

Insulator Material:

PBT

Contact:

BeCu

Plating:

10 μ" (0.25 μm) Au over 50 μ"
(1.27 μm) Ni on contact area;
Sn over 50 μ" (1.27 μm) Ni
on balance

Wire:

30 AWG

Current Rating (FFSD/FTSH):

2.3 A per pin
(2 pins powered)

Operating Temp Range:

-40 °C to +105 °C

Lead Size Accepted:

(0.41 mm) .016" SQ

Insertion Depth:

(2.64 mm) .104" to
(3.17 mm) .125"

ALSO AVAILABLE

Other Sizes
(MOQ Required)

SERIES	NO. PINS PER ROW	END OPTION	OVERALL LENGTH	01	N	OTHER OPTION
--------	------------------	------------	----------------	----	---	--------------

FFSD
= Socket Strip

-04, -05, -06, -08, -10, -11, -12, -13, -15, -17, -20, -25
(Standard sizes)

-S
= Single End
-D
= Double End

-"XX.XX"
= Assembled Length

-N
= Notch Polarization (Notch option not available with -04 position)

-RW
= Reverse Wiring (Red wire opposite position #1)

-D "XX"
= Daisy Chain

-SR
= Strain Relief (Mates only with ESHF Series) (Not available with -O, -M, -R or -DXX)

-R
= Reverse

-M
= Middle Reverse (Requires -DXX)

-O
= Outside Reverse (Requires -DXX)

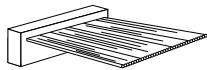
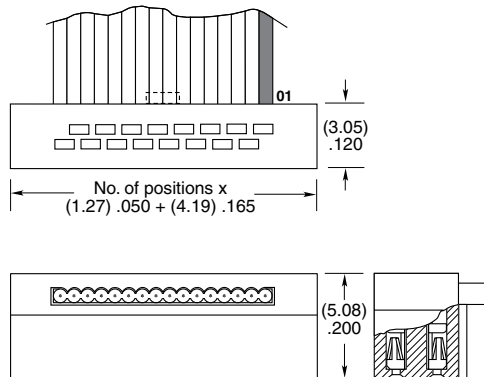

Single End (-S)

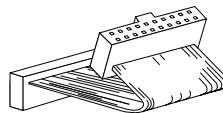

Double End (-D)

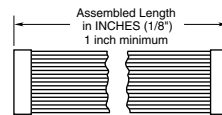

Assembled Length (-"XX.XX")

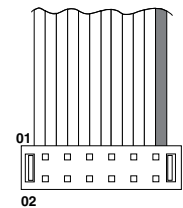

Reverse Wiring (-RW)

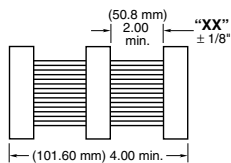

Daisy Chain (-D "XX")

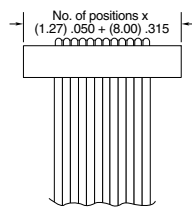

Strain Relief (-SR)

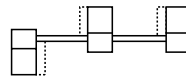

Reverse (-R)

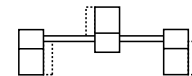

Middle Reverse (-M)

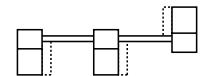

Outside Reverse (-O)

Note:

This Series is non-standard, non-returnable.

TIGER EYE™ FLAT IDC WIRE CABLES

(1.27 mm) .050" PITCH • FFMD SERIES

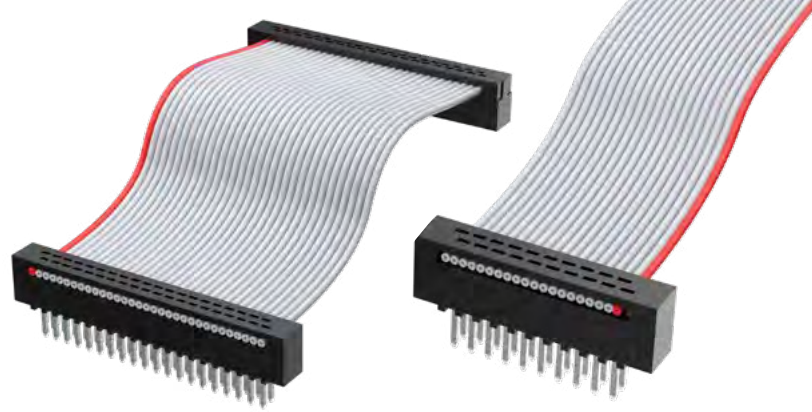

FFMD

Mates:
FLE*, SFMC*

TRANSFER END

Mates:
FTS, FTSH, EHF,
SHF, ESHF

SPECIFICATIONS

Insulator Material:

PBT
Terminal:
Phosphor Bronze
Contact:
BeCu (-T)
Plating:
Sn over 50 μ" (1.27 μm) Ni
Wire:
30 AWG
Current Rating:
2.5 A per pin
(2 pins powered)
Operating Temp Range:
-40 °C to +105 °C
Voltage Rating:
215 VAC / 304 VDC

ALSO AVAILABLE

Other sizes
(MOQ Required)

SERIES	NO. PINS PER ROW	END OPTION	OVERALL LENGTH	01	TRANSFER OPTION	OTHER OPTION
--------	------------------	------------	----------------	----	-----------------	--------------

FFMD
= Terminal Strip

-04, -05,
-08, -10,
-13, -17,
-20, -25
(Standard sizes)

-S
= Single End
-D
= Double End
-T
= Transfer End

-"XX.XX"
= Assembled Length

Leave blank for
-S and -D End Options.

-N
= Notch Polarization on socket (-T end only) (Not available with -04 position)

-RW
= Reverse Wiring (Red wire opposite position #1)

-D "XX"
= Daisy Chain

-SR
= Strain Relief (Mates only with ESHF Series) (Not available with -O, -M, -R or -DXX)

-R
= Reverse

-M
= Middle Reverse (Requires -DXX)

-O
= Outside Reverse (Requires -DXX)

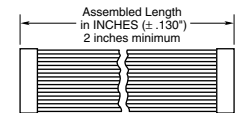
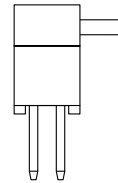
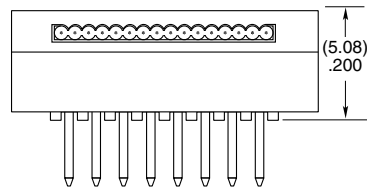
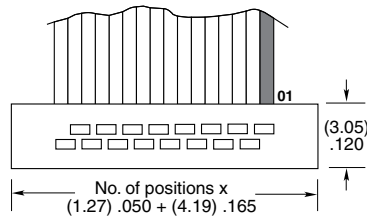

Assembled Length ("XX.XX")



Single End (-S)

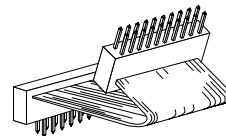

Double End (-D)

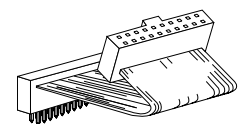

Transfer End (-T)

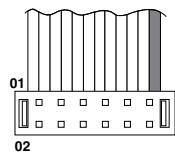

Reverse Wiring (-RW)

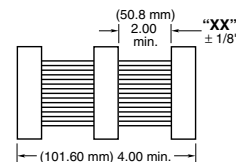

Daisy Chain (-D "XX")

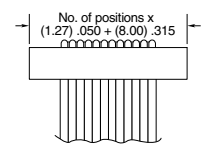

Strain Relief (-SR)

*Note:

Standard FFMD callout will not mate with FLE, SFMC. Must use gold plated callouts. (See drawing on web.) When mated with a socket, Wire 1 mates with Pin 2; Wire 2 mates with Pin 1, etc.

Note:

This Series is non-standard, non-returnable.

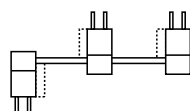

Reverse (-R)

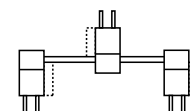

Middle Reverse (-M)

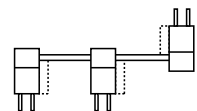

Outside Reverse (-O)

SHROUDED AND EJECTOR IDC HEADER

(1.27 mm) .050" PITCH • SHF/ESHF/EHF SERIES

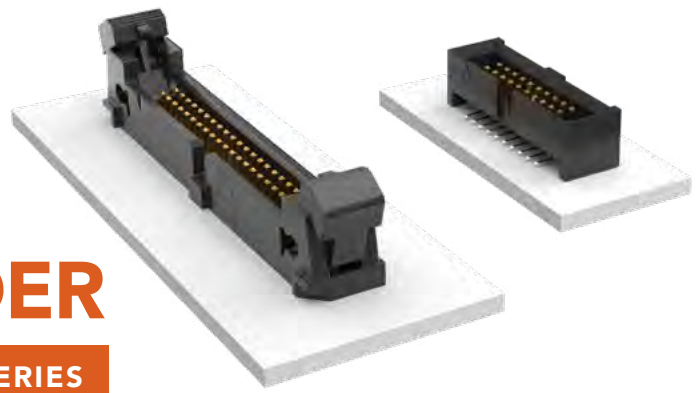

SHF/ESHF

Mates:
FFSD, FFTP (SHF)

EHF

Mates:
FFSD*, FFTP

***Important Note:**
EHF will not mate to FFSD with strain relief (-SR option), see ESHF series.

SPECIFICATIONS

Insulator Material:
Black Liquid Crystal Polymer
Terminal Material:
Phosphor Bronze
Plating:
Sn or Au over
50 μ " (1.27 μ m) Ni
Operating Temp Range:
-55 °C to +125 °C

PROCESSING

Lead-Free Solderable:
Yes
SMT Lead Coplanarity:
(0.10 mm) .004" max

SERIES	1	NO. PINS PER ROW	01	PLATING OPTION	D	TAIL OPTION	OTHER OPTION
---------------	----------	-------------------------	-----------	-----------------------	----------	--------------------	---------------------

SHF = Mates with FFSD without Strain Relief	04, 05, 06, 08, 10, 11, 12, 13, 15, 17, 20, 25 (Standard sizes)	-L = 10 μ " (0.25 μ m) Gold on post, Matte Tin on tail	-TH = Through-hole	-LC = Locking Clip (Not available with -RA) (Manual placement required)
ESHF = Mates with FFSD with Strain Relief			-RA = Right-angle	-K = (6.50 mm) .256" DIA Polyimide Film Pick & Place Pad (-SM only)
			-SM = Surface Mount	-TR = Tape & Reel
				-FR = Full Reel Tape & Reel (must order max. quantity per reel; contact Samtec for quantity breaks)

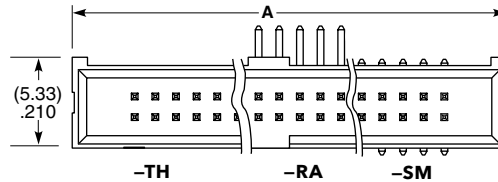

TYPE STRIP	A
SHF	No. of pins x (1.27) .050 + (6.35) .250
ESHF	No. of pins x (1.27) .050 + (10.16) .400

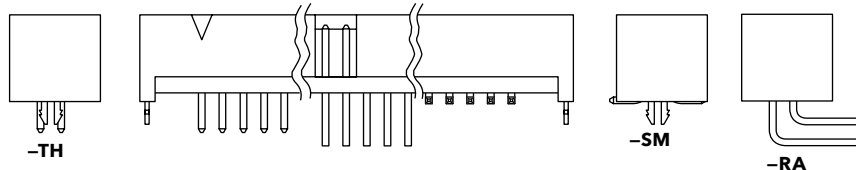

EHF	1	NO. PINS PER ROW	01	PLATING OPTION	D	TAIL OPTION	OTHER OPTION
------------	----------	-------------------------	-----------	-----------------------	----------	--------------------	---------------------

04, 05, 08, 10, 13, 17, 20, 25
(Standard sizes)

-F
= Gold flash on post, Matte Tin on tail

-L
= 10 μ " (0.25 μ m)
Gold on post, Matte Tin on tail

Leave blank for Through-hole version

-SM
= Surface Mount

-RA
= Right-angle

-"XX"
= Polarized Position (-RA not available)

-LC
= Locking Clip (-SM only)
(Manual placement required)

-K
= (7.50 mm) .295" DIA Polyimide Film Pick & Place Pad

-P
= Pick & Place Pad (-SM only)

-TR
= Tape & Reel (-LC not available)

-FR
= Full Reel Tape & Reel (must order max. quantity per reel; contact Samtec for quantity breaks)
(-LC not available)

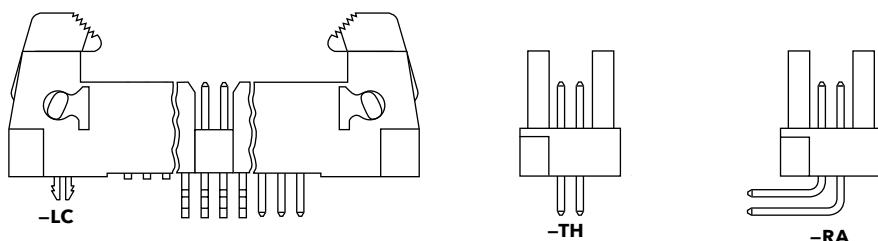
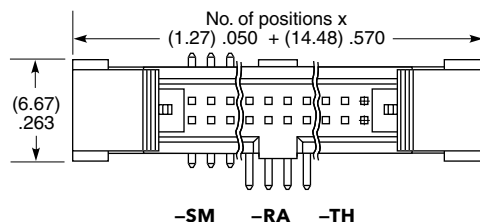

EJECTOR HEADER CAP

See samtec.com?ECF for Header cap.
(Locks FFSD cable to EHF header)

Note:
Some lengths, styles and options are non-standard, non-returnable.

TWISTED PAIR IDC CABLES

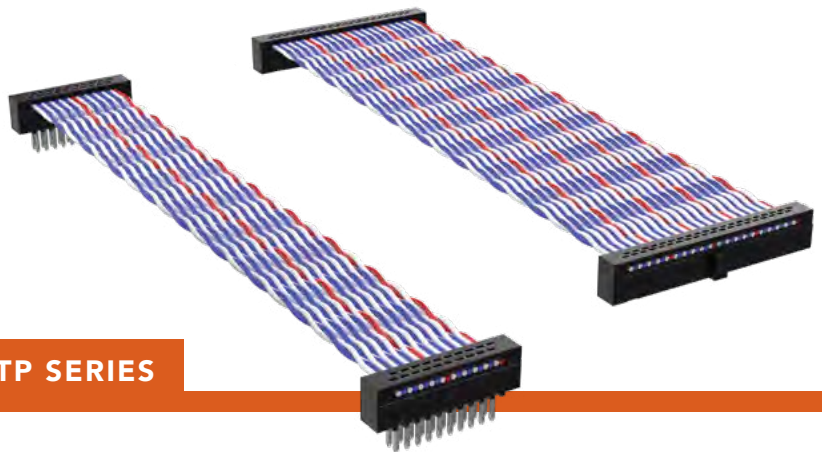

(1.27 mm) .050" PITCH • FFTP/FMTP SERIES

FFTP
Mates:
FTS, FTSH, EHF, SHF

FMTP
Mates:
FLE*, SFMC*

SPECIFICATIONS

Insulator Material:
PBT
Contact:
FFTP=BeCu
Terminal:
FMTP=Phosphor Bronze
Plating (FFTP):
FFTP=10 μ" (0.25 μm)
Au over 50 μ" (1.27 μm)
Ni on contact area; Sn over 50 μ" (1.27 μm) Ni
FMTP=Sn over 50 μ" (1.27 μm) Ni on balance
Wire:
30 AWG 7/38, Tinned, Twisted Pair with PVC insulator
Operating Temp Range:
-40 °C to +105 °C
Lead Size Accepted:
(0.41 mm) .016" SQ
Insertion Depth (FFTP):
FFTP=(2.64 mm) .104" to (3.17 mm) .125"

FFTP	NO. PINS PER ROW	END ASSEMBLY	ASSEMBLY LENGTH	01	N	OPTION
	-05, -08, -10, -13, -17, -20, -25 (Standard sizes)	-D = Double End	-03.85 = (97.79 mm) 3.85" -08.77 = (222.76 mm) 8.77" -18.00 = (457.20 mm) 18.00" (Standard lengths)		-N = Notch Polarization (Standard)	-R = Reverse Connector

ALSO AVAILABLE

Other sizes
(MOQ Required)

FMTP	NO. PINS PER ROW	END ASSEMBLY	ASSEMBLY LENGTH	01	TRANSFER OPTION	OPTION
	-05, -08, -10, -13, -17, -20, -25 (Standard sizes)	-D = Double End -T = Transfer End	-03.85 = (97.79 mm) 3.85" -08.77 = (222.76 mm) 8.77" -18.00 = (457.20 mm) 18.00" (Standard lengths)		Leave blank for -D End Assembly. For -T End Assembly Specify "-N" (Socket has notch polarization)	-R = Reverse Connector

***Note:** Standard FMTP callout will not mate with FLE, SFMC. Must use gold plated callouts. (See drawing on web.)
When mated with a socket, Wire 1 mates with Pin 2; Wire 2 mates with Pin 1, etc.

Note:
This Series is non-standard, non-returnable.

INDUSTRY STANDARDS

PRODUCT SUPPORT & EXPERTISE

Samtec provides products that interact with many types of hardware and software. This drives our need to adhere to a variety of Industry Standards. The majority of Industry Standards we engage with address the following:

- Interconnection (cables & connectors)
- Sub-systems (typically daughter or carrier cards, which include functional compliance specifications defining electro-mechanicals and mechanicals)
- Transmission protocols (primarily software and firmware defining machine language to allow communication)
- Hardware (physical electro-mechanical devices)

Visit samtec.com/standards to learn more or contact standards@samtec.com to discuss your application.

STANDARD	PRODUCT	SERIES	PAGE
VITA 42 XMC	SamArray®	YFS/YFT, JSOM	Contact Samtec.
VITA 57.1 FMC	SEARRAY™	SEAM/SEAF, JSOM	23
VITA 57.4 FMC+	SEARRAY™	SEAM/SEAF, JSOM	23
VITA 74 VNX	SEARRAY™	SEAM/SEAF, JSOM	23
COM-HPC®	AcceleRate® HP	APM6/APF6	19
MICROSAM™	1.00 mm Pitch Discrete Wire	T1M	173
PCI/104-EXPRESS™ & PCI/104-EXPRESS™ ONEBANK	Q2™	QMS/QFS	42
COAXPRESS®	HD-BNC™/FireFly™	HDBNC-TH, HDBNC-BH, HDBNC-EM, ECUO-B04	129, 166
QSFP	QSFP	FQSFP/QSFPC	99
USB/USBR	USB/AccliMate™	USB/USBR/MUSB/MUSBS/SPM, RCU/SCRU/SCPU/RPCU/RPBU/SCRUS	125-126, 225, 227
GEN-Z™	Edge Rate®	HSEC6	65

For more industry standards and products that meet them, visit samtec.com/standards.

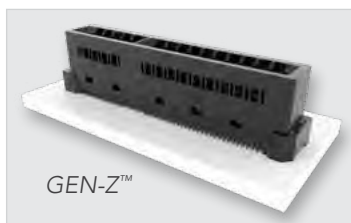
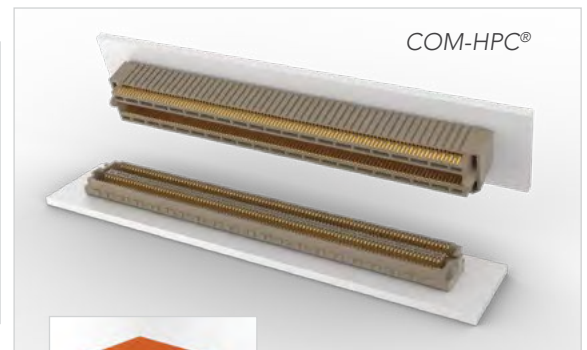
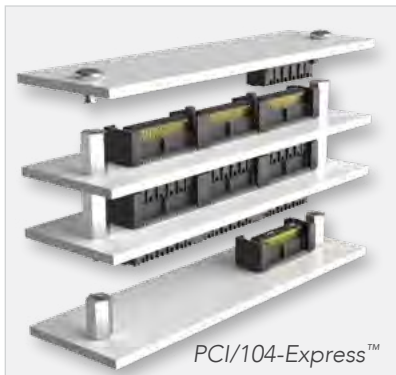

V42 XMC

Rugged Mezzanine System for High-Performance VPX Card Cages

- 3.125 Gbps performance rating
- 10 mm & 12 mm stack heights
- 96 total pins (6 x 16 configuration) with multiple points of contact
- Drop-in ready JSOM ejector jackscrews and mating high-density array cable assemblies available
- SOSA™ aligned connectors

V57.1 FMC

Leading VPX Mezzanine System for Advanced FPGA Integration

- FPGA Industry Standard connector for development applications
- 10 Gbps performance
- HPC & LPC versions (400 & 160 selectively loaded pins)
- 8.5 mm & 10 mm stack heights
- Many high-speed cable & loopback card options available
- Optional JSOM ejector jackscrews available
- SOSA™ aligned connectors

V57.4 FMC+

Advanced State-of-the-Art FPGA Mezzanine Integration

- HSPC Main Connector has 560 pins (14 x 40 configuration), 24 multi-gigabit interfaces, up to 28 Gbps
- HSPCe Extension Connector has 80 pins (4 x 20 configuration) adding 8 multi-gigabit interfaces, 32 in total
- 8.5 mm & 10 mm stack heights; 15.5 mm stack height in development
- SOSA™ aligned connectors

V57.5 FMC+

Development Tools Aid with FMC+ Applications

- Board connectors for increased stack heights to 15.5 mm
- Standoffs, loopback cards and connector extender cards
- User friendly JSOM ejector jackscrews and mating high-density array cable assemblies available

V74 VNX

Small Form Factor Nano VPX-Based Module Technology

- Rugged, high-performance, scalable, low power consumption embedded controllers
- 200 & 400 pin connector choices (Right-angle SEARAY™)
- 12.5 mm & 19 mm stack heights
- Mating high-density array cable assemblies available
- VITA 74.5 VNX in development for Optical and RF solutions

V88 XMC+

Improved Mezzanine Connectors for XMC Applications

- Compatible with VITA 42 footprints
- Improved mating/unmating forces
- PCIe® 5.0 speeds

COM-HPC®

Next-Gen Embedded System Design Scalability & Performance

- Supports edge server & robust embedded computing design applications
- System based on Samtec's AcceleRate® HP high-performance arrays
- 5 mm and 10 mm stack heights
- 400 pin count connectors
- Supports interfaces such as PCIe® 5.0 (32 GT/s) & up to 100 Gb Ethernet

MicroSAM™

Compact Computing Module Developed for Industrial IoT Sensor-Domain Control

- Utilizes PICMG sensor domain network architecture and data model for plug-and-play interoperability
- Micro 1.00 mm pitch discrete wire terminal
- 4, 6 and 18 pin configurations

PCI/104-Express™ & PCI/104-Express™ OneBank

Rugged, Stackable & Scalable Embedded Computer Applications

- Q2™ connectors with ground planes
- 3-banks have 156 signal pins, OneBank has 52 pins
- 2.5 Gbps performance
- 15.24 mm & 22 mm stack heights
- Mating high-speed, high density cable assemblies available

COAXPRESS®

Industrial/Professional Application High-Speed Imaging Standard

- Coaxial cable combined with high-speed serial data technology
- Up to 12.5 Gbps data rate per cable
- HD-BNC™ 75 Ω connectors and components
- Supports 12G-SDI protocol

QSFP

Compact, Hot-Pluggable Transceiver I/O Connector

- Flyover® solution for optimized signal integrity
- Cage and 38-pin connector
- 30 AWG 100 ohm twinax cable
- 4 high-speed Tx pairs, 4 high-speed Rx pairs
- 28 Gbps NRZ/56 Gbps PAM4 performance per channel
- Meets high-speed protocols including 40/200/400 Gb Ethernet, PCIe®, OIF-CEI-28G, SAS and SATA

GEN-Z™

Open Systems Interconnect Offering Memory-Semantic Access to Data and Devices Via Multiple Network Topologies

- High-speed, low-latency access to memory across the data center
- 0.60 mm pitch Edge Rate® high-speed edge card connectors

USB/USBR

Standardized Connection, Communication & Power Supply

- Type A, Type B, Mini, high retention and sealed versions
- IP68 sealed circular and rectangular cable systems

EVALUATION & DEVELOPMENT KITS

From concept and prototype to development and production, Samtec-designed Evaluation and Development Kits simplify the design process and reduce time to market. Kits are available for many of our high-performance connector sets, standard high-speed cable assembly, and optical configurations. Custom kits are also available via our "mix-and-match" design approach. Visit samtec.com/kits or contact kitsandboards@samtec.com for a current list of kit availability.

OPTICS/FPGA DEVELOPMENT KITS

Visit samtec.com/kits for more information.



VITA 57.4 FMC+ HSPC Loopback Card (Extender Card Available)



VITA 57.4 FMC+ HSPC / HSPCe Loopback Card (Extender Card Available)



ExaMAX[®] Loopback Card for Xilinx[®] Virtex[®] UltraScale[™] VCU110 Development Kit



FMC+ HSPC Loopback Card Supporting Xilinx[®] Virtex[®] UltraScale[™]+ VCU118 Kit

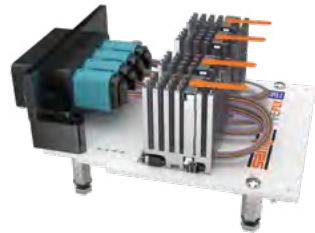

25/28 Gbps FireFly[™] FMC+ Kit



14 Gbps FireFly[™] FMC Kit



28 Gbps FireFly[™] Kit

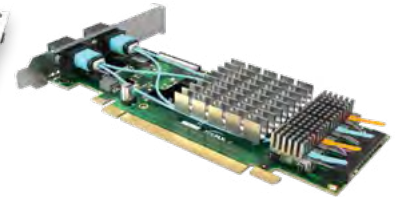

PCI Express[®]-Over-Fiber Adaptor Card (PCUO/PCOA)

CUSTOM KITS FOR APPLICATION-SPECIFIC EVALUATION

Samtec's Custom Kits make it easy to quickly obtain a robust, high-quality kit for evaluating Samtec interconnect systems. A vast library of high-performance connector and cable options is available for designing a custom solution to meet your specific evaluation needs. Contact kitsandboards@samtec.com.

END 1/END 2 OPTIONS

Twinax Flyover[®]

FQSFP-DD
FQSFP
DCH
ECUE

High-Speed Backplane

EBTF/EBTM
EBCF/EBCM
EBDM/EBCF-RA
HDTF/HDTM

High-Speed Mezzanine

NVAM/NVAF
ARF6/ARC6
ADF6/ADM6
LPAM/LPAF
ZRDP/ZCI

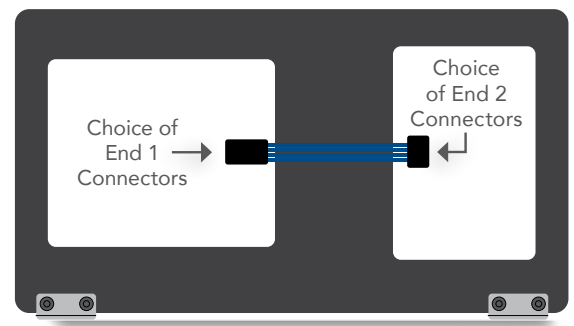

SI EVALUATION KITS: BOARD-TO-BOARD

Visit samtec.com/kits for more information.



ExaMAX® High-Speed Backplane
Traditional Connectors (EBTF/EBTM)



Edge Rate® 0.60 mm Pitch
High-Speed Edge Card (HSEC6-DV)



NovaRay™ Extreme Density Arrays
(NVAM/NVAF)



Edge Rate® Differential Pair
Edge Card (HSEC8-DP)



AcceRate® HD High-Density
Arrays (ADM6/ADF6)



LP Array™ Low-Profile Arrays
(LPAM/LPAF)



FireFly™ 20+ Gbps Edge Card
Socket (UEC5-2)

SI EVALUATION KITS: CABLE

Visit samtec.com/kits for more information.



AcceRate® Flyover® Slim
Cable Assembly (ARC6/ARF6)



NovaRay® Flyover® Extreme
Performance Cable Assembly
(NVAC/NVAM-C)



Flyover® QSFP28 Cable
System (FQSFP to ARC6/DCH)



Flyover® QSFP
Double-Density Cable System
(FQSFP-DD to NVAC/ARC6)



ExaMAX® Backplane
Cable System
(EBCM/EBTF-RA)



FireFly™ Copper
Micro Flyover System™
(ECUE/UEC5-2/UCC8)

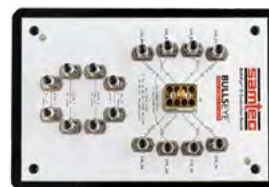

Bulls Eye® 50 GHz
High-Performance Test System
(BE40A)



Flyover® Direct Connect
Horizontal Cable System
(DCH)

TESTING

Samtec interconnects are subject to a wide variety of standard test procedures that push the industry limits to help ensure quality and durability in any application.

SEVERE ENVIRONMENT TESTING

Visit samtec.com/SET for additional information.



Severe Environment Testing (SET) is a Samtec initiative to test products beyond typical industry standards and specifications, many set forth by common requirements for rugged / harsh environment industries. These products undergo additional testing to ensure they are more than suitable for military, space, automotive, industrial and other extreme applications.

Samtec's SET products are approved for NASA Class D missions that require high-reliability, quick-turn and cost-effective solutions for LEO and GEO satellites, SmallSats, CubeSats and other space exploration applications. Visit samtec.com/SET or [contact set@samtec.com](mailto:set@samtec.com) for additional information and current available test results.

Additional Testing Includes:

MATING/UNMATING/DURABILITY

Measures the change in LLCR and mating/unmating after products have been cycled and exposed to various environmental conditions (100% relative humidity, 250 cycles).

MECHANICAL SHOCK/RANDOM VIBRATION/LLCR AND NANOSECOND EVENT DETECTION:

Measures the product's ability to withstand a series of mechanical shocks and random vibration. LLCR is a before and after check for damage. Event detection monitors continuity during testing (40G Peak, 11 ms, Half Sine & 12gRMS, 5 – 2,000 Hz, 1 Hour/Axis).

TEMPERATURE CYCLING

Evaluates the product's reliability through thermal fatigue by cycling through two temperature extremes (-65 °C to 125 °C, 30 minute dwell time at each extreme; 500 cycles).

NON-OPERATING CLASS TEMPERATURE

Determines the temperature range at which the product operates at peak level (-55 °C to 125 °C at 100 cycles and -65 °C to 125 °C at 100 cycles; 200 total cycles).

DWV AT ALTITUDE

Measures the peak voltage that a product can withstand before dielectric breakdown at high altitudes (70,000 ft).

ELECTROSTATIC DISCHARGE (ESD)

Measures the level of electrostatic voltage the product can withstand (exposure to 5k, 10k and 15k Volts, repeated 10 times).

OUTGASSING

Measures the level of gases and vapors released from non-metallic materials when exposed to extreme heat and/or a vacuum. Visit outgassing.nasa.gov for data.



EXTENDED LIFE PRODUCT™

Visit samtec.com/ELP for additional information.

E.L.P.™ products are tested to rigorous standards, which evaluate contact resistance in simulated storage and field conditions.

- 10 year Mixed Flowing Gas (MFG)
- High Mating Cycles (250 to 2,500)
- Certain plating and/or contact options will apply

For complete details about Samtec's E.L.P.™ program, a list of qualifying products and test results, please visit samtec.com/ELP or email the Customer Engineering Support Group at ASG@samtec.com.



DESIGN QUALIFICATION TESTING

All Samtec series undergo Design Qualification Testing (DQT), which includes:

- Gas Tight
- Normal Force
- Thermal Aging
- Mating/Unmating/Durability
- IR/DWV
- Current Carrying Capacity (CCC)
- Mechanical Shock/Random Vibration/LLCR
- Mechanical Shock/Random Vibration/Event Detection



TESTING REFERENCE GUIDE

TEST	SET	E.L.P.™	DQT
GAS TIGHT	X*	X*	X
NORMAL FORCE	X*	X*	X
THERMAL AGING	X*	X*	X
MATING/UNMATING/DURABILITY (240 HRS)	X (100% RH, 250 Cycles)	X* (90-98% RH, 100 Cycles)	X (90-98% RH, 100 Cycles)
IR/DWV	X (At Altitude of 70,000 Feet)	X*	X
CCC	X*	X*	X
MECHANICAL SHOCK/RANDOM VIBRATION/LLCR & NANOSECOND EVENT DETECTION	X (40 G Peak, 11 ms, Half Sine & 12gRMS, 5 - 2,000 Hz, 1 Hr / Axis)	X* (100 G Peak, 6 ms, Half Sine & 7.56gRMS Avg, 2 Hr / Axis)	X (100 G Peak, 6 ms, Half Sine & 7.56gRMS Avg, 2 Hr / Axis)
TEMPERATURE CYCLING (500 CYCLES)	X	N/A	N/A
NON-OPERATING CLASS TEMPERATURE	X	N/A	N/A
ELECTROSTATIC DISCHARGE (ESD)	X	N/A	N/A
10 YEAR MFG (MIXED FLOWING GAS)	N/A	X	N/A
MATING CYCLES (250 TO 2,500)	N/A	X	N/A

*Completed as part of initial Design Qualification Testing (DQT). E.L.P.™ and SET testing are performed in addition to DQT.

www.SAMTEC.com

Samtec is committed to the continuous evolution of our award-winning website, providing customers with innovative design tools, technical resources and support needed to make **finding, designing and ordering** the right product as easy and streamlined as possible.



Online Tools

FIND, DESIGN & VALIDATE YOUR SOLUTION

Samtec has developed innovative search, design, and validation tools to help customers quickly and easily find the right solution. Whether you prefer to search by product name or characteristics, browse through pictures, or build an assembly by entering physical specifications, Samtec offers a tool to make your search easier than ever.



Picture Search

VISUALLY FIND YOUR SOLUTION

Browse through a highlight reel of Samtec's most popular products to find the ideal solution for your application, view specifications, check availability, order samples and more. To find your solution, visit samtec.com/picturesearch.

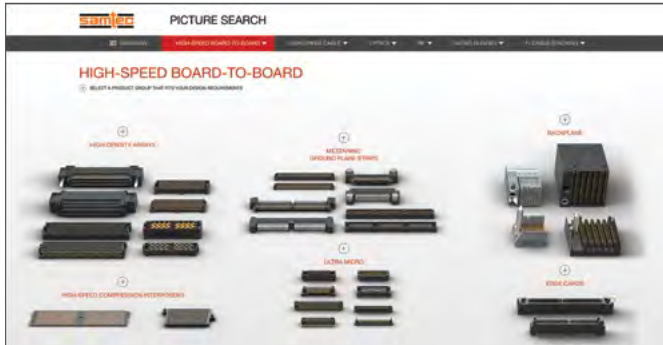

Cable Builder

HIGH-SPEED ASSEMBLIES DESIGNED IN MINUTES

Input specific options to quickly build a complete high-speed cable assembly, view specs, prints, 3D models, and instantly request samples and quotes. Visit samtec.com/cablebuilder.

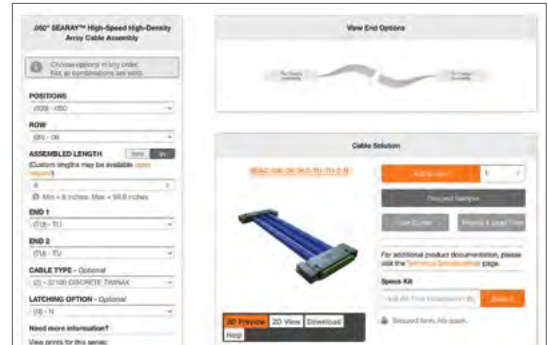

Solutionator

DESIGN IN A MINUTE

Quickly build mated connector sets using a wide variety of user-defined search parameters and filters, view specs and order samples all with one online design tool. Visit samtec.com/solutionator to start building.



Simulator

SIMULATE IN A MINUTE

Innovative design tool blends data to project performance in a user-defined system, providing insertion loss, crosstalk, eye diagrams, sample requests and more. Visit samtec.com/simulator.

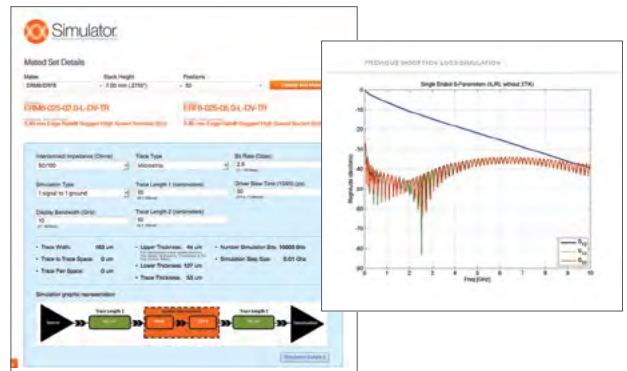



Downloads

3D MODELS, SPECS, PRINTS & MORE

Samtec's extensive library of downloadable resources is unmatched in the industry. From 3D Models and Test Reports, Interconnect Symbols and Footprints, Product Videos, Design Guides, Specifications and so much more – Samtec offers immediate and unlimited access to all the documentation you need to select the right solution for your application. Visit samtec.com to start exploring.

3D Models

Quickly configure, preview and download models in more than 150 different formats, including AutoCad, Solid Edge, Inventor and many more.

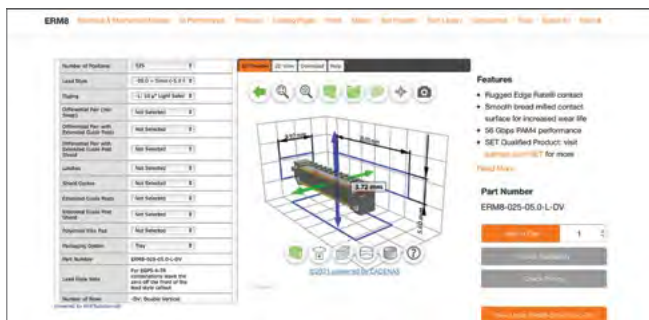

Test Reports

Samtec provides immediate access to a variety of testing and qualification reports for our products, including high-speed characterization, thermal, frequency and time domain, Extended Life Product™, Severe Environment Testing, and others.

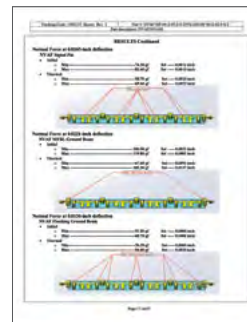

PCB Footprint / eCAD Models

Instantly view, download and design with over 200,000 ready-to-use eCAD models.

These detailed models have been formatted to work with leading schematic captures and include accurate assembly, silkscreen and 3D features.



Technical Library

Samtec's online Technical Library contains a wealth of resources, including Prints & Specifications, White Papers, Application Notes, Test Reports, Product Videos, Design Guides, Processing Information and much more.

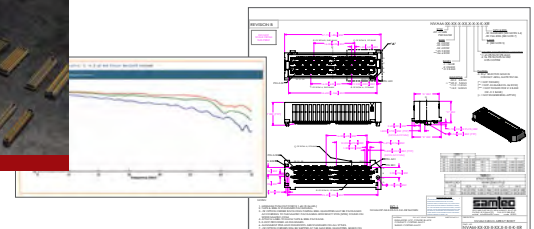
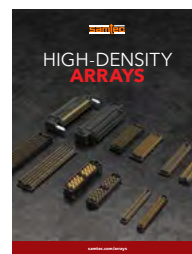

HIGH-SPEED CHANNEL PERFORMANCE

CHARACTERIZATION THAT ACCOUNTS FOR THE ENTIRE SIGNAL PATH

Samtec uses a channel-based approach to estimate connector performance in a system. The result is a realistic one number designation for all of Samtec's high-speed interconnects, called **Channel Performance Metric (CPM)**.

This one number designation allows for a side-by-side comparison of Samtec components. Noise contributions from, and interactions with, other parts of a predefined channel are considered. An example of a predefined channel is shown below.

Samtec's CPM reports connector capability that is more representative of actual performance in a system, replacing the connector only data of the past.

This real-world approach factors in all impairments, such as the crosstalk and reflections, inherent in a complete channel. Through Samtec's use of a common set of channel assumptions, relative comparison can then be made across the entire Samtec offering which is practical and realizable. Because Samtec's CPM is a function of necessary channel assumptions made, it is important to note that Samtec's CPM can and will vary from a customer specific application.

Visit samtec.com or contact SIG@samtec.com for technical support prior to final connector selection in any specific application.

Throughout the high-speed sections of this catalog, look for badges indicating Samtec's CPM one number rating for specific product series, for example:

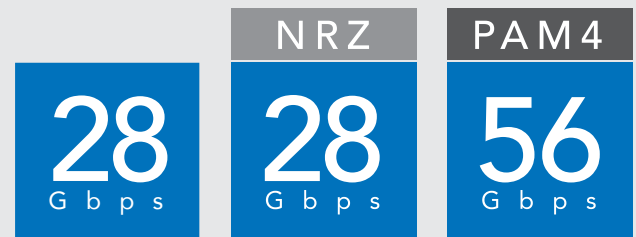

*Note: For speeds of 28 Gbps or less, NRZ encoding scheme is assumed.

Predefined Channel

Board-to-Board

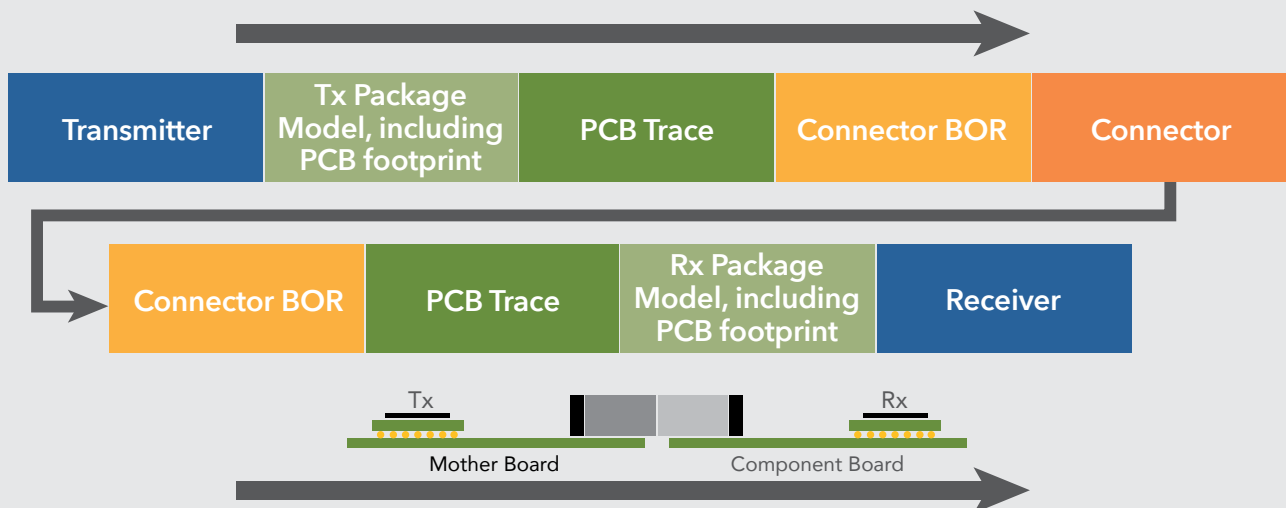

SPECIFICATIONS & TESTING



SPECIFICATIONS & STANDARD TEST PROCEDURES

Samtec products are subject to the following general specifications and standard test procedures.*

QUALITY ASSURANCE

Quality Program Certifications	IATF 16949 and/or ISO-9001
UL File Number	Visit samtec.com/quality
Sampling Procedures	ANSI/ASQ Z1.4
Calibration System Requirements	Per IATF 16949

INSULATOR

Specifications

Molding Plastics, Thermoplastic Polyesters	MIL-M-24519 Rev E
--	-------------------

Applied Tests***

Dielectric Breakdown Voltage	ASTM/ISO
AC Loss Characteristics	ASTM/ISO
Impact Resistance of Plastics	ASTM/ISO
DC Resistance	ASTM/ISO
High-Voltage, Low-Current Arc Resistance	ASTM/ISO
Water Absorption of Plastics	ASTM/ISO
Test for Tensile Properties of Plastics	ASTM/ISO
Deflection Temperature of Plastics	ASTM/ISO
Compressive Properties of Plastics	ASTM/ISO
Coefficient of Linear Thermal Expansion	ASTM/ISO
Shear Strength of Plastics	ASTM/ISO
Rockwell Hardness of Plastics	ASTM/ISO
Flexural Properties of Plastics	ASTM/ISO
Specific Gravity and Density of Plastics	ASTM/ISO

PLATING

Specifications

Gold	ASTM-B488
Tin	ASTM-B545**

Under Plating Specifications

Nickel	QQ-N-290**
Copper	AMS 2418

Applied Tests

Coating thickness (X-Ray Fluorescence)	ASTM-A-754-79
--	---------------

CONTACT & TERMINAL

Specifications***

Brass	ASTM/ISO
Phosphor Bronze	ASTM/ISO
Beryllium Copper	ASTM/ISO

ASSEMBLY

Testing Specifications

Test Methods for Electrical Connectors	EIA-364
Test Methods for Electronic/Electrical Components	EIA-364
Connections, Electrical, Solderless, Wrapped	EIA-364
Environmental Test Methods	EIA-364
Sockets (Lead, Electronic Components), General	EIA-364
Sockets, Plug-in Electronic Components, General	EIA-364

Packaging Specifications

Tape and Reel Packaging of Connectors	EIA-481
Tray Packaging of Connectors	ANSI/EIA-960
Packaging Materials for ESD Sensitive Items	ANSI/ESD S541
Package Testing Procedures	ISTA-3A

OTHER SPECIFICATIONS

Insulation Resistance	5000 M Ω min
Flammability Rating	UL 94V-0 (Typically)

PRODUCT ENVIRONMENTAL COMPLIANCE

Product environmental compliance is a part specific issue for Samtec. To confirm the environmental compliance status of any Samtec product please contact the Product Environmental Compliance Group at PEC@samtec.com and/or visit samtec.com/Quality.

Samtec has offered both lead-bearing and lead-free products for many years and will continue to support customers requiring products not compliant with the EU Directives, such as those specified for military, aerospace and specialty applications.

Proposition 65 statement: These products could expose you to chemicals which are known to the State of California to cause birth defects or other reproductive harm. For more information, visit P65Warnings.ca.gov.

LEAD FREE PROCESSING GUIDELINES

Lead-Free Wave Solderable	This product is compatible with wave solder pot temperatures between 260 °C and 270 °C with maximum exposure of the termination pins to the solder wave for 4 seconds.
Lead-Free Reflow Solderable	This product can withstand a maximum peak temperature of 260 °C, 255 °C for up to 30 seconds, and the longer dwell times required for lead-free reflow processing.

AUTOMOTIVE CERTIFICATION (ACD SERIES)

Samtec offers design and manufacture of electronic connectors, marketed as "ACD Series" (Automotive Certified Designs) for printed circuit boards. Samtec shall only comport with ISO/IATF 16949 on products it certifies as Automotive Custom Design ("ACD") or those designated with "A-" in the Samtec part number preface of the Automotive Solutions Catalog.

Download the Automotive Solutions catalog at samtec.com/catalog, or contact AutoSalesGroup@Samtec.com for qualifying products and alternative automotive application solutions.

Notes:

*Products with specifications other than those listed above are noted on the product's website page.

**With the exception of thickness.

***As dictated by material grade.

INDEX BY BRAND NAME

AcceleRate[®], AcceleRate[®] HD & AcceleRate[®] HP

APF6	0.635 mm AcceleRate [®] HP High-Performance Socket	19
APM6	0.635 mm AcceleRate [®] HP High-Performance Header	19
ADF6	0.635 mm AcceleRate [®] HD High-Density Socket	21
ADM6	0.635 mm AcceleRate [®] HD High-Density Header	21
ARC6	0.635 mm AcceleRate [®] Slim Cable	105
ARF6	0.635 mm AcceleRate [®] Slim Socket	105

AccliMate[™]

ACX-12	AccliMate IP68 Sealed 12 mm Assembly	221
ACX-16	AccliMate IP68 Sealed 16 mm Assembly	222
ACX-22	AccliMate IP68 Sealed 22 mm Assembly	223
MCP	AccliMate IP67 Mini Push-Pull Cable Assembly	224
MCR	AccliMate IP67 Mini Push-Pull Panel Assembly	224
SCRJUS	AccliMate IP68 Sealed Circular USB 2.0 Panel Mount Socket	225
SCRSES	AccliMate IP68 Sealed Circular Ethernet Cable Socket	225
RPBE	AccliMate IP68 Sealed Ethernet Panel Mount Socket	226
RPCPE	AccliMate IP68 Sealed Ethernet Panel Mount Socket Cable	226
RPBU	AccliMate IP68 Sealed USB Panel Mount Socket	227
RPCU	AccliMate IP68 Sealed USB Panel Mount Cable	227

Edge Rate[®]

ERF5	0.50 mm Edge Rate [®] Rugged High-Speed Socket	49
ERM5	0.50 mm Edge Rate [®] Rugged High-Speed Header	49
ERF6	0.635 mm Edge Rate [®] Rugged High-Speed Socket	50
ERM6	0.635 mm Edge Rate [®] Rugged High-Speed Header	50
ERF8	0.80 mm Edge Rate [®] Rugged High-Speed Socket	51, 53, 54
ERM8	0.80 mm Edge Rate [®] Rugged High-Speed Header	51, 52, 54
HSEC6	0.60 mm Edge Rate [®] Vertical Card Socket	65
HSEC8	0.80 mm Edge Rate [®] Card Socket	67, 68, 69, 70
ECDP	0.80 mm Edge Card Twinax Cable Assembly	112
ERDP	0.80 mm Edge Rate [®] Twinax Cable Assembly	114
ERCD	0.80 mm Edge Rate [®] Coax Cable Assembly	117

ExaMAX[®]

EBTM	2 mm ExaMAX [®] Header	87
EBTF-RA	2 mm ExaMAX [®] Right-Angle Socket	88
EBDM-RA	2 mm ExaMAX [®] Direct Mate Orthogonal Header	88
EPT(X)	ExaMAX [®] Power Module	89
EGB(X)	2 mm ExaMAX [®] Guide Module	89
EBCM	2 mm ExaMAX [®] Backplane Cable Header	90
EBCF	2 mm ExaMAX [®] Cable Socket	90

Eye Speed[®] I/O, Eye Speed[®] HD

HDLSF	0.635 mm Eye Speed [®] HD I/O High-Speed Cable System	122
HDC/HD16	Eye Speed [®] HD I/O Cage & Socket for HDLSF	122
EPLSP	0.80 mm Eye Speed [®] Rugged Latching High-Speed Cable System	123
ERC	0.80 mm Eye Speed [®] Cage for ER18-RA	123
ER18-RA	0.80 mm Eye Speed [®] Right-Angle Edge Rate [®] Socket	123
SFPE	SFP+ Copper I/O Cable Assembly	124
SFPC	SFP+ Transceiver Cage	124
SFPK	SFP+ Cage and Connector Kit	124

FireFly[™] & Flyover[®]

FQSF	Flyover [®] QSFP Cable System	99
FQSF-DD	Flyover [®] QSFP Double Density System	100
ECUE	FireFly [™] 38 AWG Copper Micro Flyover System [™]	109
PCUE	FireFly [™] PCIe-over-FireFly [™] Copper Flyover [®] Cable	109
UCCB	FireFly [™] Positive Latching Receptacle	110
UECS	FireFly [™] Edge Card Socket	110
ECUO	FireFly [™] Optical Micro Flyover System [™]	129
ETUO	FireFly [™] Extended Temp Optical Micro Flyover System [™]	130
PCUO	FireFly [™] PCIe-over-Fiber FireFly [™] Cable	131
PCOA	FireFly [™] PCIe-over-Fiber FireFly [™] Adaptor Card	132

Flex Stack

AW	0.80 mm Flex Stack, Surface Mount Micro Board Stacker	243
MW	1 mm Flex Stack, Surface Mount Micro Board Header	245
FW	1.27 mm Flex Stack, Micro Board Stacker	251
ZML	1.27 mm Flex Stack, Shrouded Elevated Stacker	255
DWM	1.27 mm Flex Stack, Flexible Micro Board Stacker	256
HDWM	1.27 mm Flex Stack, High Temp Micro Board Stacker	256
LTM	2 mm Flex Stack, Shrouded Terminal Strip	264
ZLTM	2 mm Flex Stack, Shrouded Elevated Terminal Strip	264
TW-SM	2 mm Flex Stack, Flexible Board Stacker, SMT	266
HMTSW	2.54 mm Flex Stack, High Temp Modified SQ Post Header	278, 279
MTSW	2.54 mm Flex Stack, Modified SQ Post Header	278, 279
MTLW	2.54 mm Flex Stack, Low-Profile .025" SQ Post Header	280
TLW	2.54 mm Flex Stack, Low-Profile .025" SQ Post Header	280
HW	2.54 mm Flex Stack, Flexible Board Stacker	281
DW	2.54 mm Flex Stack, Flexible Board Stacker, .110" Tail	282
EW	2.54 mm Flex Stack, Flexible .025" SQ Board Stacker	282
ZW	2.54 mm Flex Stack, Flexible .025" SQ Board Stacker	282
HTSS	2.54 mm High Temp Shrouded Terminal	283
TSS	2.54 mm Flex Stack, Shrouded Header	283
ZSS	2.54 mm Flex Stack, Elevated Shrouded Header	283
HTST	2.54 mm High Temp Shrouded Cable Terminal	299
TST	2.54 mm Flex Stack, Shrouded Cable Header	299
ZST	2.54 mm Flex Stack, Elevated Shrouded Cable Header	299
STMM	2 mm Flex Stack, Shrouded Terminal Cable Strip	303
ZSTMM	2 mm Flex Stack, Shrouded Elevated Cable Header	303

FleXYZ[™]

TMM-TH	2 mm FleXYZ [™] Low-Profile Through-Hole Header	260
MTMM	2 mm FleXYZ [™] Modified Through-Hole Header	261
TMMH-TH	2 mm FleXYZ [™] Flexible Through-Hole Header	263
TW-TH	2 mm FleXYZ [™] Flexible Board Stacker, Through-Hole	266
ESQT	2 mm FleXYZ [™] Flexible Elevated Socket Strip	268
SQW	2 mm FleXYZ [™] Cost-Effective Rugged Socket, Solder Tail	269
SQT	2 mm FleXYZ [™] Cost-Effective Rugged Socket, Square Tail	269

FOURRAY[™]

FOLC	1.27 mm FOURRAY [™] High-Density Tiger Eye [™] Socket	188
MOLC	1.27 mm FOURRAY [™] High-Density High-Reliability Header	188
SOLC	0.635 mm FOURRAY [™] Quad Row SMT Socket	247
TOLC	0.635 mm FOURRAY [™] Quad Row SMT Terminal	247

LP Array[™]

LPAF	1.27 mm LP Array [™] High-Speed Open-Pin-Field Socket	29
LPAM	1.27 mm LP Array [™] High-Speed Open-Pin-Field Terminal	29

Micro Mate[™]

S1SS(T)	1 mm Discrete Wire Socket Assembly, Single Row	174
S1SD(T)	1 mm Discrete Wire Socket Assembly, Double Row	175
T1PS(T)	1 mm Discrete Wire Panel Mount Terminal, Single Row	176
T1SS(T)	1 mm Discrete Wire Terminal Assembly, Single Row	176
T1PD(T)	1 mm Discrete Wire Panel Mount Terminal, Double Row	177
T1SD(T)	1 mm Discrete Wire Terminal Assembly, Double Row	177

Mini Mate[®]

IP51	2.54 mm Mini Mate [®] Isolated Power Connector Socket	213
IP11	2.54 mm Mini Mate [®] Isolated Power Connector Terminal	213
IPL1	2.54 mm Mini Mate [®] Shrouded Power Cable Terminal	214
MMSX(T)	2.54 mm Mini Mate [®] Discrete Wire Cable	215

mPOWER[®]

UMPS	mPOWER [®] Ultra Micro Power Socket	197
UMPT	mPOWER [®] Ultra Micro Power Terminal	198
UMPC	mPOWER [®] Ultra Micro Power Cable	199

NovaRay[®]

NVAF	NovaRay [®] Extreme Density & Performance Socket	17
NVAM	NovaRay [®] Extreme Density & Performance Terminal	17
NVAC	NovaRay [®] Extreme Density & Performance Cable	103
NVAM-C	NovaRay [®] Terminal for NVAC Series	103

PowerStrip[™]

UPPT	3.81 mm PowerStrip [™] 720 Amp Hermaphroditic Power System	201
UPS	3.81 mm PowerStrip [™] 720 Amp Dual Leaf Power Socket	201
UPT	3.81 mm PowerStrip [™] 720 Amp Dual Blade Power Terminal	201
MPS	5 mm PowerStrip [™] 30 Amp Dual Leaf Socket	202
MPT	5 mm PowerStrip [™] 30 Amp Dual Blade Terminal	202
MPCS	PowerStrip [™] 30 Amp Signal/Power Combo Socket	204
MPTC	PowerStrip [™] 30 Amp Signal/Power Combo Terminal	204
MPSS	5 mm PowerStrip [™] 30 Amp Power Cable Assembly	203
MPCS	PowerStrip [™] 30 Amp Combo Cable Assembly	205
PES	6.35 mm PowerStrip [™] 40 Amp High Power Socket	206
PET	6.35 mm PowerStrip [™] 40 Amp High Power Terminal	206
PESC	PowerStrip [™] 40 Amp Signal/Power Socket	206
PETC	PowerStrip [™] 40 Amp Signal/Power Terminal	206
PESS	6.35 mm PowerStrip [™] 40 Amp Cable Assembly	207
LPHS	PowerStrip [™] EXTreme LPHPower [™] Socket	209
LPHT	PowerStrip [™] EXTreme LPHPower [™] Terminal	209
ET60S	PowerStrip [™] EXTreme Ten60Power [™] Socket	211
ET60T	PowerStrip [™] EXTreme Ten60Power [™] Terminal	211

Power Mate[®]

IPBS	4.19 mm Power Mate [®] Isolated Power Socket	216
IPBT	4.19 mm Power Mate [®] Isolated Power Terminal	216
PMSX(T)	4.19 mm Power Mate [®] Discrete Wire Power Cable	217

Q Strip[®], Q Pairs[®]

QSH	0.50 mm Q Strip [®] High-Speed Ground Plane Socket	39, 46
QTH	0.50 mm Q Strip [®] High-Speed Ground Plane Header	39, 46
QSE	0.80 mm Q Strip [®] High-Speed Ground Plane Socket	40
QTE	0.80 mm Q Strip [®] High-Speed Ground Plane Header	40
QSS	0.635 mm Q Strip [®] High-Speed Ground Plane Socket	41, 46
QTS	0.635 mm Q Strip [®] High-Speed Ground Plane Header	41, 46
EQDP	0.80 mm Q Pairs [®] Twinax Cable Assembly	113
HQDP	0.50 mm Q Pairs [®] Twinax Cable Assembly	113
EQCD	0.80 mm Q Strip [®] Coax Cable Assembly	116
HQCD	0.50 mm Q Strip [®] Coax Cable Assembly	116

Q Rate[®]

QRFB	0.80 mm Q Rate [®] Slim Body Ground Plane Socket	44, 47
QRMB	0.80 mm Q Rate [®] Slim Body Ground Plane Header	44, 47

Q2[™]

QFS	0.635 mm Q2 [™] Rugged Ground Plane Socket	42, 47
QMS	0.635 mm Q2 [™] Rugged Ground Plane Header	42, 47
QFSS	0.635 mm Q2 [™] Shielded Ground Plane Socket	43
QMSS	0.635 mm Q2 [™] Shielded Ground Plane Header	43

Razor Beam[™]

LSHM	0.50 mm Razor Beam [™] High-Speed Hermaphroditic Strip	57
LSEM	0.80 mm Razor Beam [™] High-Speed Hermaphroditic Strip	58
LSS	0.635 mm Razor Beam [™] High-Speed Hermaphroditic Strip	58
HLCD	0.50 mm Razor Beam [™] High-Speed Cable Assembly	115

SEARAY[™] 0.80 mm

SEAF8	0.80 mm SEARAY [™] Ultra-High Density Open-Pin-Field Socket	27
SEAM8	0.80 mm SEARAY [™] Ultra-High Density Open-Pin-Field Terminal	27
ESCA	0.80 mm SEARAY [™] High-Speed Cable Assembly	119

SEARAY[™]

SEAF	1.27 mm SEARAY [™] High-Density Open-Pin-Field, Socket	23, 24
SEAM	1.27 mm SEARAY [™] High-Density Open-Pin-Field, Terminal	23, 24
SEAFP	1.27 mm SEARAY [™] Press-Fit High-Density Array, Socket	25
SEAMP	1.27 mm SEARAY [™] Press-Fit High-Density Array, Terminal	25
SEAMI	1.27 mm SEARAY [™] 85 Ω-tuned High-Density Array, Terminal	25
SEAR	1.27 mm SEARAY [™] High-Density Riser, 85 Ω	25
SEAC	1.27 mm SEARAY [™] High-Speed/High-Density Jumper	118

Si-Fly[™]

CPC	Si-Fly [™] Low-Profile High-Density Copper Cable	107
CPI	Si-Fly [™] Low-Profile High-Density Interconnect	107

Tiger Beam[™]

CLE	0.80 mm Tiger Beam [™] Cost-Effective Micro Socket	242
MLE	1 mm Tiger Beam [™] Cost-Effective Micro Socket	246
FLE	1.27 mm Tiger Beam [™] Cost-Effective Reliable Socket	253
TLE	2 mm Tiger Beam [™] Cost-Effective Reliable Socket	271
HLE	2.54 mm Tiger Beam [™] Cost-Effective Reliable Socket	288

Tiger Buy[™]

SLM	1.27 mm Tiger Buy [™] Low-Profile Through-Hole Micro Socket	258
SMS	1.27 mm Tiger Buy [™] Through-Hole Micro Socket	258
LS2	2 mm Self-Mating Hermaphroditic Strip	272
SSQ	2.54 mm Tiger Buy [™] Socket .025" SQ Post	284
SSW	2.54 mm Tiger Buy [™] Socket	284, 285
ESQ	2.54 mm PC/104 [™] Elevated Socket	287
ESW	2.54 mm PC/104 [™] Elevated Socket	287
BSW	2.54 mm Bottom Mount Socket Strip	290
SLW	2.54 mm Tiger Buy [™] Low-Profile Socket Strip	291

Tiger Claw[™]

CLM	1 mm Tiger Claw [™] Rugged Reliable Micro Socket	246
CLP	1.27 mm Tiger Claw [™] Low-Profile Dual Wipe Socket	252
MMS	2 mm Tiger Claw [™] Socket Strip	270
CLT	2 mm Tiger Claw [™] Low-Profile Dual Wipe Socket	271
SSM	2.54 mm Tiger Claw [™] Pass-Through SMT Socket	286
BCS	2.54 mm Tiger Claw [™] Pass-Through Through-Hole Socket	289

Tiger Eye[™]

SEM	0.80 mm Tiger Eye [™] Micro Socket	179
SESDT	0.80 mm Tiger Eye [™] Discrete Wire Socket Cable	181
SFM	1.27 mm Tiger Eye [™] High-Reliability Socket	183
SFML	1.27 mm Tiger Eye [™] High-Reliability Locking Socket	183
SFC	1.27 mm Tiger Eye [™] Cost-Effective Reliable Socket	185
SFSX(T)	1.27 mm Tiger Eye [™] Discrete Wire Cable	186, 187
SFMC	1.27 mm Tiger Eye [™] Flexible Pin Count Socket	189
S2M	2 mm Tiger Eye [™] Discrete Wire Cable Socket	191
S2SD(T)	2 mm Tiger Eye [™] Discrete Wire Socket Cable	192
SMM	2 mm Tiger Eye [™] High-Reliability Socket	194
TCSD	2 mm Tiger Eye [™] IDC Socket Cable	300
TCMD	2 mm Tiger Eye [™] IDC High-Reliability Header Cable	301
FFSD	1.27 mm Tiger Eye [™] IDC Ribbon Cable Assembly, Female	304
FFMD	1.27 mm Tiger Eye [™] IDC Ribbon Cable Assembly, Male	305
FFTP	1.27 mm Tiger Eye [™] IDC Twisted Pair Cable, Female	307
FFMP	1.27 mm Tiger Eye [™] IDC Twisted Pair Cable, Male	307

XCede[®] HD

HDTM	1.80 mm XCede [®] HD Vertical Backplane Header	93
HDTF	1.80 mm XCede [®] HD Right-Angle Backplane Receptacle	94
HPTS	XCede [®] HD Power Module	94

Z-Ray[®]

ZA8	0.80 mm Z-Ray [®] Ultra-Low Profile Compression Interposers	33
ZA8H	0.80 mm Z-Ray [®] High-Speed Compression Interposers	33
ZA1	1 mm Z-Ray [®] High-Speed Compression Interposers	34

Series	Description	Page	Series	Description	Page
135	50 Ω Precision 1.35 mm Compression Jacks	140	RF047	50 Ω Flexible RF Cable Assembly, (.047" DIA) 28 AWG	169
185	50 Ω Precision 1.85 mm Compression Jacks	141	RF047-A	50 Ω .047" Overshield DIA, 29 AWG mmWave Cable	140, 141, 142, 143, 146
240	50 Ω Precision 2.40 mm Compression Jacks	142	RF058	50 Ω RF Cable Assembly, RG 58 Cable	158, 161
292	50 Ω Precision 2.92 mm Compression Jacks	143	RF085	50 Ω .085" Overshield DIA 24 AWG mmWave Cable	142, 143
BE70A	70 GHz Bulls Eye® Assembly, Double Row	153	RF086	50 Ω .086" Overshield DIA 23 AWG mmWave Cable	141, 142, 143, 146
BE40A	50 GHz & 40 GHz Bulls Eye® Assembly, Double Row	154	RF23C	50 Ω MWC-2350CU-01 mmWave Cable with Copper Shield	142, 143, 146
BDRA	20 GHz Bulls Eye® Assembly, Double Row	154	RF23S	50 Ω MWC-2350-01 μWave Cable with 23 AWG Solid FEP Dielectric	144
BNC5-CA	50 Ω BNC Cable Connectors	162	RF25S	50 Ω MWC-2550-01 μWave Cable with 25 AWG Solid FEP Dielectric	145, 148
BNC7T	75 Ω 12G-SDI BNC Jacks	165	RF120	50 Ω MWC-19550-FCU-01 19 AWG mmWave Cable	142, 143
BNC7T-CA	75 Ω 12G-SDI BNC Cable Connectors	164	RF174	50 Ω RF Cable Assembly, RG 174 Cable	158, 159, 160, 161, 162, 163
BQRA	20 GHz Bulls Eye® Assembly, Quad Row	154	RF178	50 Ω RF Cable Assembly, RG 178 Cable	158, 159, 160, 161, 162, 163
C28S	100 Ω Shielded Twisted Pair Twinax Cable Assembly	169	RF179	75 Ω RF Cable Assembly, RG 179 Cable	164, 167, 168
CJT	100 Ω Twinax Jacks	169	RF180	50 Ω .178" Overshield DIA, 16 AWG μWave Cable	145, 150, 151
DIN7A	75 Ω, 12G-SDI DIN 1.0/2.3 Jacks	167	RF280	50 Ω .277" Overshield DIA, 11 AWG μWave Cable	145, 150, 151
DIN7A-CA	75 Ω, 12G-SDI DIN 1.0/2.3 Cable Connectors	167	RF316	50 Ω RF Cable Assembly, RG 316 Cable	158, 159, 160, 161, 162, 163
GC47	50 Ω Precision Ganged SMPM Cable Assembly	147	RF402	50 Ω RG 402 19 AWG Semi-flexible μWave Cable	145
GPPB	50 Ω Precision Ganged SMPM Block, Board-to-Board	147	RF405	50 Ω RG 405 24 AWG Semi-flexible μWave Cable	145, 148
GPPC	50 Ω Ganged SMPM Cable Board Mates	147	RFA6T	75 Ω RF Cable Assembly, RG 6 Cable	164, 166, 167
GRF1-C	5.00 mm 50 Ω Ganged Micro-Mini RF Plugs, Cable	169	RFB6T	75 Ω RF Cable Assembly, 1694A Cable	164, 166, 167
GRF1H-C	5.00 mm 50 Ω Ganged Hybrid Micro-Mini RF Cable	169	RFB8T	75 Ω RF Cable Assembly, 1855A Cable	166, 167
GRF1-J	5.00 mm 50 Ω Ganged Micro-Mini RF Jacks, PCB Mount	169	RFC6T	75 Ω RF Cable Assembly, Belden 4694R Cable	164, 166, 167
GRF1-P	5.00 mm 50 Ω Ganged Micro-Mini RF Plugs, PCB Mount	169	RFC8T	75 Ω RF Cable Assembly, Belden 4855R Cable	166, 167
GRF7-C	5.00 mm 75 Ω Ganged Micro-Mini RF Plugs, Cable	169	RS316	50 Ω RF Cable Assembly, Double-Shielded RG 316 Cable	158, 159, 160, 161, 162
GRF7H-C	5.00 mm 75 Ω Ganged Hybrid Micro-Mini RF Cable	169	SMB5	50 Ω SMB Jacks	163
GRF7-P	5.00 mm 75 Ω Ganged Micro-Mini RF Plugs, PCB Mount	169	SMB5-CA	50 Ω SMB Cable Connectors	163
GRF7-J	5.00 mm 75 Ω Ganged Micro-Mini RF Jacks, PCB Mount	169	SMB7H	75 Ω SMB Jacks	168
HDBNC	75 Ω, 12G-SDI High-Density BNC Jacks	166	SMB7H-CA	75 Ω SMB Cable Connectors	168
HDBNC-CA	75 Ω, 12G-SDI High-Density Cable Connectors	166	SMA	50 Ω Precision SMA Jacks	145
IJ5	4.00 mm IsoRate® 50 Ω High Isolation RF Jack Strip	169	SMA-CA	50 Ω SMA Low Frequency Cable Connectors	158
IJ5C	4.00 mm IsoRate® 50 Ω High Isolation RF Cable	169	SMP	50 Ω Precision SMP Plugs & Bullet Adaptors	149
IJ5H	4.00 mm IsoRate® 50 Ω High Isolation Hybrid Cable	169	SMPM	50 Ω Precision SMPM Plugs	146
IP5	4.00 mm IsoRate® 50 Ω High Isolation RF Plug Strip	169	TNC	50 Ω TNC Jacks	161
MCX	50 Ω MCX Jacks & Plugs	159	TNC-CA	50 Ω TNC Cable Connectors	161
MCX7	75 Ω MCX Jacks & Plugs	169			
MCX7-CA	75 Ω MCX Cable Connectors	169			
MCX-CA	50 Ω MCX Cable Connectors	159			
MMCX	50 Ω MMCX Jacks & Plugs	160			
MMCX-CA	50 Ω MMCX Cable Connectors	160			
MMCX7	75 Ω MMCX Jacks & Plugs	169			
MMCXV	50 Ω MMCX High-Vibration Jacks & Plugs	169			
MMCXV-CA	50 Ω MMCX High-Vibration Cable Connectors	169			
MH081	50 Ω Micro High-Frequency RF Cable, 0.81 mm DIA	157			
MH113	50 Ω Micro High-Frequency RF Cable, 1.13 mm DIA	157			
PRF00	Precision SMP Cable Connectors, 40 GHz	148			
PRF01	Precision SMA Cable Connectors, 18 GHz	145			
PRF04	Precision TNCA Cable Connectors, 18 GHz	151			
PRF06	Precision N Type Cable Connectors, 18 GHz	150			
PRF10	Precision 1.00 mm Cable Connectors, 110 GHz	140			
PRF13	Precision 1.35 mm Cable Connectors, 90 GHz	140			
PRF18	Precision 1.85 mm Cable Connectors, 65 GHz	141			
PRF24	Precision 2.40 mm Cable Connectors, 50 GHz	142			
PRF92	Precision 2.92 mm Cable Connectors, 40 GHz	143			
PRF35	Precision 3.50 mm Cable Connectors, 34 GHz	144			
PRFIA	Precision SMPM Bullet Adaptors, 65 GHz	147			
PRFM0	Precision SMPM Cable Connectors, 65 GHz	146			
PRFS1	Precision SSMA Cable Connector, 34 GHz	144			



INDEX BY SERIES

Series	Description	Page	Series	Description	Page	Series	Description	Page
ACD	Automotive Certified Design	317	ERM5	0.50 mm Edge Rate [®] Rugged High-Speed Header	49	HSS	2.54 mm High Temp Single Row Machined Socket	**
ACP-12	AccliMate™ IP68 Sealed 12 mm Cable Assembly	221	ERM6	0.635 mm Edge Rate[®] Rugged High-Speed Header	50	HTEC8	0.80 mm Rugged High-Speed Card Socket	66
ACP-16	AccliMate™ IP68 Sealed 16 mm Cable Assembly	222	ERM8	0.80 mm Edge Rate [®] Rugged High-Speed Header	51	HTMS	1.27 mm High Temp Through-Hole Micro Terminal	254
ACP-22	AccliMate™ IP68 Sealed 22 mm Cable Assembly	223	ERM8-EM	0.80 mm Edge Rate [®] Rugged Edge Mount Header	52	HTS	2.54 mm High Temp Single Row Machined Terminal	**
ACP-12	AccliMate™ IP68 Sealed 12 mm Panel Assembly	221	ERM8-RA	0.80 mm Edge Rate [®] Rugged Right-Angle Header	52	HTSS	2.54 mm High Temp Shrouded Terminal	283
ACP-16	AccliMate™ IP68 Sealed 16 mm Panel Assembly	222	ESCA	0.80 mm SEARAY™ High-Speed Cable Assembly	119	HTST	2.54 mm High Temp Shrouded Cable Terminal	299
ACP-22	AccliMate™ IP68 Sealed 22 mm Panel Assembly	223	ESD	2.54 mm Elevated Double Row Screw Machined Socket	**	HTSW	2.54 mm High Temp Terminal	274
ADF6	0.635 mm AccelRate [®] HD High-Density Socket	21	ESHF	1.27 mm Shrouded Ejector IDC Header	306	HW-SM	2.54 mm Flex Stack, Board Stacker, Surface Mount	281
ADM6	0.635 mm AccelRate [®] HD High-Density Header	21	ESQ	2.54 mm PC/104™ Elevated Socket	287	HW-TH	2.54 mm Flex Stack, Board Stacker, Through-Hole	281
APF6	0.635 mm AccelRate[®] HP High-Performance Socket	19	ESQT	2 mm FlexYZ™ Flexible Elevated Socket Strip	268	IDMX	2.54 mm Slim IDC Ribbon Cable, Terminal	296
APM6	0.635 mm AccelRate[®] HP High-Performance Header	19	ESQT-368	2 mm PC/104-Plus™ Self-Nesting Socket	268	IDP1	1 mm Discrete Wire Double Row Panel Mount Housing	177
ARC6	0.635 mm AccelRate[®] Slim Cable	105	ESS	2.54 mm Elevated Single Row Screw Machined Socket	**	IDSX	2.54 mm Slim IDC Ribbon Cable, Socket	296
ARF6	0.635 mm AccelRate[®] Slim Socket	105	ESW	2.54 mm PC/104™ Elevated Socket	287	IDT1	1 mm Discrete Wire Double Row Terminal Housing	177
ASP	Application Specific Product	14	ET60S	2.54 mm PowerStrip™ EXtreme Ten60Power™ Socket	211	IMSS	PowerStrip™/30 Amp Discrete Wire Socket Housing	203
AW	0.80 mm Flex Stack, Surface Mount Micro Board Stacker	243	ET60T	2.54 mm PowerStrip™ EXtreme Ten60Power™ Terminal	211	IMSC5	PowerStrip™/30 Amp Discrete Wire Combo Housing	205
BBD	2.54 mm Double Row, Machined Terminal Strip	**	ETMM	2 mm Shrouded Strain Relief IDC Header	302	IPBD	4.19 mm Power Mate [®] Discrete Wire Socket Housing	217
BBL	2.54 mm Low-Profile Single Row, Machined Terminal Strip	**	ETUO	FireFly™ Extended Temp Optical Micro Flyover System™	130	IPBS	4.19 mm Power Mate [®] Isolated Power Socket	216
BBS	2.54 mm Single Row, Machined Terminal Strip	**	EW	2.54 mm Flex Stack, Flexible .025" SQ Board Stacker	282	IPBT	4.19 mm Power Mate [®] Isolated Power Terminal	216
BCS	2.54 mm Tiger Claw™ Pass-through Through-Hole Socket	289	FC1	1 mm Flat Flexible Cable (FFC) Socket	295	IPD1	2.54 mm Mini Mate [®] Discrete Wire Socket Housing	215
BDL	2.54 mm Low-Profile Double Row, Machined Terminal Strip	**	FCDP	0.50 mm High-Speed Edge Card Socket for FEDP	111	IPL1	2.54 mm Mini Mate [®] Shrouded Power Cable Terminal	214
BHS	2.54 mm High Temp Single Row, Machined Terminal Strip	**	FEDP	0.50 mm High-Speed Edge Card Cable Assembly	111	IPS1	2.54 mm Mini Mate [®] Isolated Power Connector Socket	213
BKS	1 mm Polarized Micro Socket	**	FCF8	0.80 mm High-Speed Cost-Effective Coax Cable Assembly	121	IPS6	6.35 mm PowerStrip™/40 Amp Discrete Wire Header	207
BKT	1 mm Polarized Micro Terminal	**	FCS8	0.80 mm High-Speed Cost-Effective Coax Cable Socket	121	IPT1	2.54 mm Mini Mate [®] Isolated Power Connector Terminal	213
BSE	0.80 mm Basic Blade & Beam Socket	241	FFMD	1.27 mm Tiger Eye™ IDC Ribbon Cable Assembly, Male	305	ISD1	1 mm Discrete Wire Double Row Socket Housing	175
BSH	0.50 mm Basic Blade & Beam Socket	239	FFSD	1.27 mm Tiger Eye™ IDC Ribbon Cable Assembly, Female	304	ISD2	2 mm Tiger Eye™ Discrete Wire Socket Housing	192
BSS	0.635 mm Basic Blade & Beam Socket	240	FFTP	1.27 mm Tiger Eye™ IDC Twisted Pair Cable, Female	307	ISDE	0.80 mm Tiger Eye™ Discrete Wire Socket Housing	181
BSW	2.54 mm Bottom Mount Socket Strip	290	FHP	3.96 mm Power Eye Socket	218	ISDF	1.27 mm Tiger Eye™ Discrete Wire Socket Housing	186
BTE	0.80 mm Basic Blade & Beam Header	241	FJ	1 mm Flat Flexible Cable (FFC) Jumper	295	ISP1	1 mm Discrete Wire Single Row Panel Mount Housing	176
BTH	0.50 mm Basic Blade & Beam Header	238	EJH	0.50 mm Flat Flexible Cable (FFC) Jumper	294	ISS1	1 mm Discrete Wire Single Row Socket Housing	174
BTS	0.635 mm Basic Blade & Beam Header	240	FLE	1.27 mm Tiger Beam™ Cost-Effective Reliable Socket	253	IST1	1 mm Discrete Wire Single Row Terminal Housing	176
CC03	Tiger Eye™ Contact for ISDF	186	FMPS	5 mm PowerStrip™/30 Amp "Hinging" Power Socket	**	JL	2.54 mm Jumper Link	292
CC09	Contact for ISS1/ISD1	174	FMPT	5 mm PowerStrip™/30 Amp "Hinging" Power Header	**	JSO	Jack Screw Precision Board Stacking Standoff	30
CC10	PowerStrip™ Contact for IPS6	207	FOLC	1.27 mm Tiger Eye™ IDC Twisted Pair Cable, Male	307	JSOM	Micro Jack Screw Precision Board Stacking Standoff	**
CC396	Tiger Eye™ Contact for ISDE	181	FOPC	1.27 mm FOURRAY™ High-Density Tiger Eye™ Socket	188	JW	3.96 mm Flex Stack, Power Board Stacker	218
CC46	PowerStrip™ Contact for IMSS and IMSC5	203	FQSF	Fiber Optic Patch Cable	133	LPAF	1.27 mm LP Array™ High-Speed Open-Pin-Field Array	29
CC69	Power Mate [®] Contact for IPBD	217	FQSF-DD	Flyover™ QSFP Double Density Cable System	100	LPAM	1.27 mm LP Array™ High-Speed Open-Pin-Field Array	29
CC79	Mini Mate [®] Contact for IPD1	215	FSS	0.50 mm High-Speed Floating Contact Socket	237	LPHS	PowerStrip™ EXtreme LPHPower™ Socket	209
CC81	Tiger Eye™ Contact for ISD2, IMSC5 and CCX	192	FSI	1 mm One-Piece Interface	234	LPHT	PowerStrip™ EXtreme LPHPower™ Terminal	209
CCR-12	AccliMate™ IP68 Crimped 12 mm Cable Assembly	**	FIS	0.50 mm High-Speed Floating Contact Terminal	237	LP-FQSF	Light Pipe for QSFP and HS-QSFP	99
CCR-12	AccliMate™ IP68 Crimped 12 mm Panel Assembly	**	FTE	0.80 mm SMT Micro Header	242	LS2	2 mm Self-Mating Hermaphroditic Strip	272
CCRB-12	AccliMate™ IP68 Crimped 12 mm Panel Receptacle	**	FTM	1 mm SMT Micro Low-Profile Terminal Strip	244	LSEM	0.80 mm Razor Beam™ High-Speed Hermaphroditic Strip	58
CES	2.54 mm Closed Entry Low-Profile Socket Strip	291	FTMH	1 mm SMT Micro Terminal Strip	244	LSH	0.50 mm Low-Profile Blade & Beam Socket	236
CLE	0.80 mm Cost-Effective Micro Socket	242	FTR	1.27 mm SMT Micro Terminal Strip	257	LSHM-DH	0.50 mm Razor Beam™ Right-Angle Hermaphroditic Strip	57
CLM	1 mm Tiger Claw™ Rugged Reliable Micro Socket	246	FTS	1.27 mm Micro Low-Profile Terminal Strip	250	LSHM-DV	0.50 mm Razor Beam™ High-Speed Hermaphroditic Strip	57
CLP	1.27 mm Low-Profile Dual Wipe Socket	252	FTSH-SM	1.27 mm SMT Micro Terminal Strip	248	LSHM-RH	0.50 mm Razor Beam™ Reversed -RA Hermaphroditic Strip	57
CLT	2 mm Low-Profile Dual Wipe Socket	271	FTSH-TH	1.27 mm Through-Hole Micro Terminal Strip	249	LSS	0.635 mm Razor Beam™ High-Speed Hermaphroditic Strip	58
CPC	Si-Fly™ Low-Profile High-Density Copper Cable	107	FWJ	3.96 mm Power Terminal Strip	218	LTH	0.50 mm Low-Profile Blade & Beam Terminal	236
CPI	Si-Fly™ Low-Profile High-Density Interconnect	107	FW-SM	1.27 mm Flex Stack, SMT Micro Board Stacker	251	LTHM	2 mm Shrouded Terminal Strip	264
DW	2.54 mm Flex Stack, Flexible Board Stacker, .110" Tail	282	FW-TH	1.27 mm Flex Stack, Through-Hole Micro Board Stacker	251	MCP	AccliMate™ IP67 Mini Push-Pull Cable Assembly	224
DWM	1.27 mm Flex Stack, Flexible Micro Board Stacker	256	GMI	Low-Profile One-Piece Compression Interposer	36	MCR	AccliMate™ IP67 Mini Push-Pull Panel Assembly	224
EBCB	ExaMAX™ Panel Retention Bracket	91	HCMX	2.54 mm IDC Assembly, Terminal	**	MEC1-DV	1 mm Mini Edge Card Socket, Vertical	77
EBCF	2 mm ExaMAX™ Backplane Cable Socket	90	HCSX	2.54 mm IDC Assembly, Socket	**	MEC1-EM	1 mm Mini Edge Card Socket, Edge Mount	78
EBCL	ExaMAX™ Vertical Latching Shroud	91	HDC	Eye Speed™ HD I/O Cage for HDLSP/HDi6	122	MEC1-RA	1 mm Mini Edge Card Socket, Right-Angle	78
EBCM	2 mm ExaMAX™ Backplane Cable Header	90	HDi6	0.635 mm Eye Speed™ HD I/O Socket for HDLSP	122	MEC2-DV	2 mm Mini Edge Card Socket, Vertical Surface Mount	79
EBDM-RA	2 mm ExaMAX™ Direct Mate Orthogonal Header	88	HDLSP	0.635 mm Eye Speed™ HD I/O High-Speed Cable System	122	MEC2-TH	2 mm Mini Edge Card Socket, Vertical Through-Hole	79
EBTF-RA	2 mm ExaMAX™ Backplane Socket, Right-Angle	88	HDWM	1.27 mm Flex Stack, High Temp Micro Board Stacker	256	MEC5-DV	0.50 mm Micro Edge Card Socket, Vertical	73
EBTM	2 mm ExaMAX™ Backplane Header	87	HDTF	1.80 mm XCede™ HD Right-Angle Backplane Receptacle	94	MEC5-RA	0.50 mm Micro Edge Card Socket, Right-Angle	73
ECDP	0.80 mm Twinax Edge Card Cable Assembly	112	HDTM	1.80 mm XCede™ HD Vertical Backplane Header	93	MEC6-DV	0.635 mm Micro Edge Card Socket, Vertical	74
ECUE	FireFly™ Copper Micro Flyover System™	109	HPWJ	3.96 mm High Temp Power Header	218	MEC6-RA	0.635 mm Micro Edge Card Socket, Right-Angle	74
ECUO	FireFly™ Optical Micro Flyover System™	129	HLCD	0.50 mm Razor Beam™ High-Speed Cable Assembly	115	MEC8-DV	0.80 mm Micro Edge Card Socket, Vertical	75
EGBF	ExaMAX™ Socket Guide Module	89	HLE	2.54 mm Tiger Beam™ Cost-Effective Reliable Socket	288	MEC8-RA	0.80 mm Micro Edge Card Socket, Right-Angle	76
EGBM	ExaMAX™ Terminal Guide Module	89	HMTMS	1.27 mm Flex Stack, High Temp Modified Micro Header	**	MEC8-EM	0.80 mm Micro Edge Card Socket, Edge Mount	76
EHF	1.27 mm Shrouded IDC Ejector Header	306	HMTSW	2.54 mm Flex Stack, High Temp Modified SQ Post Header	278	MEC8-VP	0.80 mm Micro Edge Card Socket, Press-Fit	75
EHT	2 mm Shrouded IDC Ejector Header	302	HPF	5.08 mm Power Socket	219	MECF	1.27 mm Mini Edge Card Socket, Vertical	79
EJH	2.54 mm Shrouded IDC Ejector Header	298	HPM	5.08 mm Power Header	219	MECT	0.80 mm SFP+ Edge Card Connector	124
EPLSP	0.80 mm Eye Speed™ Rugged Latching Cable System	123	HPTS	XCede™ HD Power Module	94	MILE	1 mm Tiger Beam™ Cost-Effective Micro Socket	246
EPTS	ExaMAX™ Socket Power Module	89	HPW	5.08 mm Power Board Stacker	219	MMS	2 mm Tiger Claw™ Socket Strip	270
EPTT	ExaMAX™ Terminal Power Module	89	HQCD	0.50 mm Q Strip™ Coax Cable Assembly	116	MMSD(T)	2.54 mm Mini Mate [®] Discrete Wire Cable, Double Row	215
EQCD	0.80 mm Q Strip™ Coax Cable Assembly	116	HQDP	0.50 mm Q Pairs™ Twinax Cable Assembly	113	MMS(T)	2.54 mm Mini Mate [®] Discrete Wire Cable, Single Row	215
EQDP	0.80 mm Q Pairs™ Twinax Cable Assembly	113	HSC8	0.80 mm High-Speed Riser Card	**	MMT	2 mm Horizontal Surface Mount Terminal	261
EQRD	0.80 mm Q Rate™ Coax Cable Assembly	**	HSEC1-DV	1 mm Edge Rate™ Vertical Card Socket	71	MNT	2.54 mm Multi-Position Shunt	292
ERC	0.80 mm Eye Speed™ Cage for ER18-RA	123	HSEC6-DV	0.60 mm Edge Rate™ Vertical Card Socket	65	MQLC	1.27 mm FOURRAY™ High-Density High-Reliability Header	188
ERCD	0.80 mm Edge Rate™ Coax Cable Assembly	117	HSEC8-DP	0.80 mm Edge Rate™ Differential Pair Card Socket	70	MPCC	PowerStrip™/30 Amp Combo Assembly	205
ERDP	0.80 mm Edge Rate™ Twinax Cable Assembly	114	HSEC8-DV	0.80 mm Edge Rate™ Vertical Card Socket	67	MPPT	5 mm PowerStrip™/30 Amp Hermaphroditic Power System	**
ERF5	0.50 mm Edge Rate™ Rugged High-Speed Socket	49	HSEC8-EM	0.80 mm Edge Rate™ Edge Mount Card Socket	68	MPS	5 mm PowerStrip™/30 Amp Dual Leaf Socket	202
ERF6	0.635 mm Edge Rate™ Rugged High-Speed Socket	50	HSEC8-PE	0.80 mm Edge Rate™ Pass-Through Card Socket	69	MPS-RA	5 mm PowerStrip™/30 Amp Right-Angle Power Socket	202
ERF8	0.80 mm Edge Rate™ Rugged High-Speed Socket	51	HSEC8-PV	0.80 mm Edge Rate™ Power/Signal Combo Socket	69	MPC	PowerStrip™/30 Amp Signal/Power Combo Socket	204
ERF8-EM	0.80 mm Edge Rate™ Rugged Edge Mount Socket	53	HSEC8-RA	0.80 mm Edge Rate™ Right-Angle Card Socket	68	MPS-RA	PowerStrip™/30 Amp Right-Angle Signal/Power Socket	204
ERF8-RA	0.80 mm Edge Rate™ Rugged Right-Angle Socket	53	HS-QSFP	Heat Sink for QSFP	99	MPSS	5 mm PowerStrip™/30 Amp Power Cable	203
ER18-RA	0.80 mm Eye Speed™ Right-Angle Edge Rate™ Socket	123	HS-QSFP-DD	Heat Sink for QSFP-DD	101			

INDEX BY SERIES

Series	Description	Page	Series	Description	Page	Series	Description	Page
MPT	5 mm PowerStrip™/30 Amp Dual Blade Terminal	202	SEAFP-RA	1.27 mm SEARAY™ Press-Fit Right-Angle Array, Socket	**	TFM	1.27 mm Tiger Eye™ High-Reliability Header	184
MPT-RA	5 mm PowerStrip™/30 Amp Right-Angle Power Terminal	202	SEAM	1.27 mm SEARAY™ High-Density Open-Pin-Field, Terminal	23	TFML	1.27 mm Tiger Eye™ High-Reliability Locking Header	184
MPTC	PowerStrip™/30 Amp Signal/Power Combo Terminal	204	SEAM-GP	1.27 mm SEARAY™ High-Density Guide Post Array, Terminal	24	TLE	2 mm Tiger Beam™ Cost-Effective Reliable Socket	271
MPTC-RA	PowerStrip™/30 Amp Right-Angle Signal/Power Terminal	204	SEAM-RA	1.27 mm SEARAY™ Right-Angle Open-Pin-Field, Terminal	24	TLH	0.50 mm Micro Blade & Beam Ultra-Low Profile Header	61
MTLW	2.54 mm Flex Stack, Low-Profile .025" SQ Post Header	280	SEAM8	0.80 mm SEARAY™ Ultra-High-Density Array, Terminal	27	TLW	2.54 mm Flex Stack, Low-Profile .025" SQ Post Header	280
MTMM	2 mm FlexYZ™ Modified Through-Hole Header	261	SEAMI	1.27 mm SEARAY™ 85 Ω High-Density Array, Terminal	25	TML	1.27 mm Shrouded Micro Header	255
MTMS	1.27 mm Flex Stack, Modified Micro Header	**	SEAMP	1.27 mm SEARAY™ Press-Fit High-Density Array, Terminal	25	TMM-SM	2 mm Low-Profile SMT Header	259
MTSW	2.54 mm Flex Stack, Modified SQ Post Header	278	SEAR	1.27 mm SEARAY™ High-Density Riser, 85 Ω	25	TMM-TH	2 mm FlexYZ™ Low-Profile Through-Hole Header	260
MW	1 mm Flex Stack, Surface Mount Micro Board Header	245	SEI	1 mm Single Row One-Piece Interface	**	TMMH-SM	2 mm Flexible SMT Header	262
			SEM	0.80 mm Tiger Eye™ Micro Socket	179	TMMH-TH	2 mm FlexYZ™ Flexible Through-Hole Header	263
NVAC	NovaRay™ Extreme Density & Performance Cable	103	SEMS	0.80 mm Tiger Eye™ Slim Micro Socket	179	TMMMS	2 mm Shrouded Quad Row Header	265
NVAF	NovaRay™ Extreme Density & Performance Socket	17	SESDT	0.80 mm Tiger Eye™ Discrete Wire Socket Cable Assembly	181	TMS	1.27 mm Through-Hole Micro Header	254
NVAM	NovaRay™ Extreme Density & Performance Terminal	17	SFC	1.27 mm Tiger Eye™ Cost-Efficient Reliable Socket	185	TOLC	0.635 mm FOURRAY™ Quad Row SMT Terminal	247
NVAM-C	NovaRay™ Terminal for NVAC Series	103	SFM	1.27 mm Tiger Eye™ High-Reliability Socket	183	TS	2.54 mm Single Row Screw Machined Terminal	**
OPA	Optical Patch Adaptor	133	SFMC	1.27 mm Tiger Eye™ Flexible Pin Count Socket	189	TSH	2 mm Shrouded Header	265
PCIE	1 mm PCI Express® Edge Card Socket	81	SFML	1.27 mm Tiger Eye™ High-Reliability Locking Socket	183	TSM	2.54 mm SMT .025" SQ Post Header	276
PCIE-G4	1 mm PCI Express® 4.0 Edge Card Socket	82	SFPC	SFP+ Transceiver Cage	**	TSS	2.54 mm Flex Stack, Shrouded Header	283
PCIE-G5	1 mm PCI Express® 5.0 Edge Card Socket	82	SFPE	SFP+ Copper I/O Cable Assembly	124	TSSH	2.54 mm Shrouded .025" SQ Post Header	**
PCIE-LP	1 mm PCI Express® Low-Profile Edge Card Socket	81	SFPK	SFP+ Cage and Connector Kit	**	TST	2.54 mm Flex Stack, Shrouded Cable Header	299
PCIEC	1 mm PCI Express® Internal Cable Assembly	120	SFSD(T)	1.27 mm Tiger Eye™ Discrete Wire Cable, Double Row	187	TSW	2.54 mm Through-Hole .025" SQ Post Header	274
PCOA	PCle®-Over-Fiber FireFly™ Adaptor Card	132	SFSS(T)	1.27 mm Tiger Eye™ Discrete Wire Cable, Single Row	186	T1PD(T)	1 mm Discrete Wire Panel Mount Terminal, Double Row	177
PCUC	PCle®-Over-FireFly™ Copper Flyover® Cable	109	SHF	1.27 mm Shrouded IDC Header	306	T1PS(T)	1 mm Discrete Wire Panel Mount Terminal, Single Row	176
PCUO	PCle®-Over-Fiber FireFly™ Cable	131	SIB	2.54 mm One-Piece Interfaces	235	T1SD(T)	1 mm Discrete Wire Terminal Assembly, Double Row	177
PES	6.35 mm PowerStrip™/40 Amp High Power Socket	206	SIBF	1.27 mm One-Piece Interfaces	**	T1SS(T)	1 mm Discrete Wire Terminal Assembly, Single Row	176
PESC	PowerStrip™/40 Amp Signal/Power Socket	206	SIR1	2.54 mm One-Piece Right-Angle Interfaces	235	TW-SM	2 mm Flex Stack, Flexible Board Stacker, SMT	266
PESS	6.35 mm PowerStrip™/40 Amp Cable Assembly	207	SL	2.54 mm Low-Profile Single Row Machined Socket	**	TW-TH	2 mm FlexYZ™ Flexible Board Stacker, Through-Hole	266
PET	6.35 mm PowerStrip™/40 Amp High Power Terminal	206	SLH	0.50 mm Micro Blade & Beam Ultra-Low Profile Socket	61	2SN	2 mm Shunt	292
PETC	PowerStrip™/40 Amp Signal/Power Terminal	206	SLM	1.27 mm Tiger Buy™ Low-Profile Micro Socket	258	UCC8	FireFly™ Positive Latching Receptacle	110
PHF	2.54 mm Press-Fit Socket	273	SLW	2.54 mm Tiger Buy™ Low-Profile Socket Strip	291	UEC5	FireFly™ Edge Card Socket	110
PHT	2.54 mm Press-Fit Terminal	273	SMH	2.54 mm SMT Horizontal Socket	**	UMPC	mPOWER™ Ultra Micro Power Cable	199
PMSD(T)	4.19 mm Power Mate® Discrete Wire Cable, Double Row	217	SMM	2 mm Tiger Eye™ High-Reliability Socket	194	UMPS	mPOWER™ Ultra Micro Power Socket	197
PMS(S)	4.19 mm Power Mate® Discrete Wire Cable, Single Row	217	SMS	1.27 mm Through-Hole Micro Socket	258	UMPT	mPOWER™ Ultra Micro Power Terminal	198
PIF	2 mm Press-Fit Socket	267	SNM	2.54 mm Micro Shunt	292	UPPT	3.81 mm PowerStrip™/20 Amp Hermaphroditic Power System	201
PIHF	2 mm PC/104-Plus™ Self-Nesting Socket	268	SNT	2.54 mm Shunt	292	UPS	3.81 mm PowerStrip™/20 Amp Dual Leaf Power Socket	201
PIIT	2 mm Press-Fit Terminal	267	SO	Precision Board Stacking Standoff	62	UPT	3.81 mm PowerStrip™/20 Amp Dual Blade Power Terminal	201
QFS	0.635 mm Q2™ Rugged Ground Plane Socket	42	SOLC	0.635 mm FOURRAY™ Quad Row SMT Socket	247	USB-A	Standard USB 2.0, A-Type	125
QFS-EM	0.635 mm Q2™ Ground Plane Socket, Edge Mount	47	SQT	2 mm FlexYZ™ Cost-Effective Rugged Socket, Square Tail	269	USB-AM	Standard USB 2.0, A-Type Plug	125
QFS-RA	0.635 mm Q2™ Ground Plane Socket, Right-Angle	47	SQW	2 mm FlexYZ™ Cost-Effective Rugged Socket, Solder Tail	269	USB-B	Standard USB 2.0, B-Type	126
QFSS	0.635 mm Q2™ Shielded Ground Plane Socket	43	SS	2.54 mm Single Row Screw Machined Socket	**	USB-R	High-Retention USB 2.0 Interface, A-Type	125
QMS	0.635 mm Q2™ Rugged Ground Plane Header	42	SS4	0.40 mm Micro Blade & Beam Ultra-Fine Pitch Socket	59	USBR-A	High-Retention USB 2.0 Interface, A-Type	125
QMS-EM	0.635 mm Q2™ Ground Plane Header, Edge Mount	47	SS5	0.50 mm Micro Blade & Beam Low-Profile Socket	60	USBR-B	High-Retention USB 2.0 Interface, B-Type	126
QMS-RA	0.635 mm Q2™ Ground Plane Header, Right-Angle	47	SSQ	2.54 mm Tiger Claw™ Pass-Through SMT Socket	286	ZA1	1 mm Z-Ray™ Ultra-Low Profile Compression Interposers	34
QMSS	0.635 mm Q2™ Shielded Ground Plane Header	43	SSW	2.54 mm Tiger Buy™ Socket .025" SQ Post	284	ZAB	0.80 mm Z-Ray™ Ultra-Low Profile Compression Interposers	33
QRF8	0.80 mm Q Rate™ Slim Body Ground Plane Socket	44	SSW-SM	2.54 mm Tiger Buy™ Through-Hole Socket	284	ZABH	0.80 mm Z-Ray™ High-Speed Compression Interposers	33
QRF8-RA	0.80 mm Q Rate™ Slim Body Socket, Right-Angle	47	ST4	2.54 mm Tiger Buy™ SMT Socket	285	ZCC	0.80 mm Z-Ray™ Cable Cage	**
QRMB	0.80 mm Q Rate™ Slim Body Ground Plane Header	44	ST5	0.40 mm Micro Blade & Beam Ultra Fine Pitch Header	59	ZCI	0.80 mm Z-Ray™ Cable Interposer	**
QRMB-RA	0.80 mm Q Rate™ Slim Body Header, Right-Angle	47	QRT8	0.80 mm Micro Blade & Beam Low-Profile Header	60	ZD	Z-Ray™ Alignment Dowel	35
QSE	0.80 mm Q Strip™ High-Speed Ground Plane Socket	40	QRM8-RA	2 mm Flex Stack, Shrouded Terminal Cable Strip	303	ZF1	1 mm Flat Flexible Cable (FFC) Socket	295
QSFP	Cage for QSFP	99	T1M	1 mm Discrete Wire Terminal	173	ZFSS	0.50 mm Flat Flexible Cable (FFC) Socket	294
QSFP-CDD	Cage for QSFP-CDD	101	T2M	2 mm High-Reliability Discrete Wire Cable Header	191	ZHSI	Z-Ray™ Press-Fit Alignment Hardware	35
QSH	0.50 mm Q Strip™ High-Speed Ground Plane Socket	39	T2SD(T)	2 mm Tiger Eye™ Discrete Wire Terminal Cable Terminal for T1XX(T)	193	ZLTMM	2 mm Flex Stack, Shrouded Elevated Terminal Strip	264
QSH-RA	0.50 mm Q Strip™ High-Speed Socket, Right-Angle	46	TC37	2 mm Tiger Eye™ IDC High-Reliability Header Cable	176	ZML	1.27 mm Flex Stack, Shrouded Elevated Stacker	255
OSS	0.635 mm Q Strip™ High-Speed Ground Plane Socket	41	TCMD	2 mm Tiger Eye™ IDC Socket Cable	301	ZRDP	0.80 mm Z-Ray™ Ultra-Low Profile Cable	**
OSS-RA	0.635 mm Q Strip™ Ground Plane Socket, Right-Angle	46	TCSD	2.54 mm Double Row Screw Machine Terminal	300	ZSO	Z-Ray™ Press-Fit Alignment Hardware	35
QTE	0.80 mm Q Strip™ High-Speed Ground Plane Header	40	TD	2.54 mm Double Row Screw Machine Terminal	**	ZSS	2.54 mm Flex Stack, Elevated Shrouded Header	283
QTH	0.50 mm Q Strip™ High-Speed Ground Plane Header	39	TEM	0.80 mm Tiger Eye™ Micro Header	179	ZST	2.54 mm Flex Stack, Elevated Shrouded Cable Header	299
QTH-RA	0.50 mm Q Strip™ High-Speed Header, Right-Angle	46	TEMS	0.80 mm Tiger Eye™ Micro Header, Slim	179	ZSTMM	2 mm Flex Stack, Shrouded Elevated Cable Header	303
QTS	0.635 mm Q Strip™ High-Speed Ground Plane Header	41	TFC	1.27 mm Tiger Eye™ Cost-Effective Reliable Header	185	ZW	2.54 mm Flex Stack, Flexible .025" SQ Board Stacker	282
QTS-RA	0.635 mm Q Strip™ Ground Plane Header, Right-Angle	46						
RPBE	AcciMate™ IP68 Sealed Ethernet Panel Mount Socket	226						
RPBU	AcciMate™ IP68 Sealed USB Panel Mount Socket	227						
RPCE	AcciMate™ IP68 Sealed Ethernet Panel Mount Socket Cable	226						
RPCU	AcciMate™ IP68 Sealed USB Panel Mount Cable	227						
RSM	1.27 mm Surface Mount Micro Socket	257						
RUB	0.80 mm High-Speed Edge Card Riser Kit	**						
S1SD(T)	1 mm Discrete Wire Socket Assembly, Double Row	175						
S1SS(T)	1 mm Discrete Wire Socket Assembly, Single Row	174						
S2M	2 mm Tiger Eye™ Discrete Wire Cable Socket	191						
S2SD(T)	2 mm Tiger Eye™ Discrete Wire Socket Cable	192						
SAL1	1 mm High-Speed Micro Plane Socket	83						
SCRES	AcciMate™ IP68 Sealed Circular Ethernet Cable Socket	225						
SCRUS	AcciMate™ IP68 Sealed Circular USB 2.0 Panel Mount Socket	225						
SD	2.54 mm Double Row Screw Machined Socket	**						
SDL	2.54 mm Double Row Low-Profile Screw Machined Socket	**						
SEAC	1.27 mm SEARAY™ High-Speed/High-Density Jumper	118						
SEAF	1.27 mm SEARAY™ High-Density Open-Pin-Field, Socket	23						
SEAF-RA	1.27 mm SEARAY™ Right-Angle Open-Pin-Field, Socket	24						
SEAF8	0.80 mm SEARAY™ Ultra-High-Density Array, Socket	27						
SEAF8-RA	0.80 mm SEARAY™ Right-Angle Open-Pin-Field, Socket	27						
SEAFP	1.27 mm SEARAY™ Press-Fit High-Density Array, Socket	25						

RF PRODUCTS

See page 319 for available RF Solutions.

GENERAL POLICY INFORMATION

Unless otherwise agreed by Samtec in writing, all sales of Samtec products are subject to Samtec's Terms and Conditions of Sale located at <https://www.samtec.com/about/legal#samtecterms>

Federal Supply Code: 55322

Notes:

**Products available on website

New products highlighted in bold.

Most older products not shown in the catalog are still available.

Visit www.samtec.com and the home page search bar for availability and specifications.

High-Speed
Board-to-Board

High-Speed
Cables

Optics

Precision RF

Micro/Rugged

Flexible Stacking



Scan the Code to Find Your
Samtec Location or Visit:
[samtec.com/locations](https://www.samtec.com/locations)

samtec

SUDDEN SERVICE®

www.samtec.com

ISO-9001 and/or IATF 16949 Certified

© MARCH 2021, SAMTEC INC.