

200mA Negative Voltage Regulator with ON/OFF Control

GENERAL DESCRIPTION

The XC6901 Series is a negative voltage CMOS regulator which includes a reference voltage source, error amplifier, driver transistor, current limiter and phase compensator.

The CE function enables the circuit to be in stand-by mode by inputting low level signal. In the stand-by mode, the electric charge at the output capacitor (C_L) will be discharged via the internal auto-discharge switch and as a result the $-V_{OUT}$ pin quickly returns to the V_{SS} level.

The over current protection circuit will operate when the output current reaches limit current. The thermal shutdown circuit will operate when the junction temperature reaches limit temperature.

APPLICATIONS

- Negative power supplies
- Modules (Wireless LAN, Digital still cameras, etc)
- Digital still cameras
- Mobile devices / terminals

FEATURES

Maximum Output Current	: 200mA
Input Voltage Range	: -2.4V ~ -12.4V($V_{CE}=3.6V$)
Output Voltage Range	: -0.9V ~ -12.0V
Accuracy	: $\pm 1.5\%$ ($V_{OUT} < -2.0V$) $\pm 0.03V$ ($V_{OUT} \geq -2.0V$)
Temperature Stability	: TYP. $\pm 50\text{ppm}/^\circ\text{C}$
CE High Level Voltage	: +1.2V ~ +3.6V,(Active High)
Dropout Voltage	: 400mV@ $I_{OUT}=100\text{mA}$
Low Power Consumption	: 100 μA MAX.
Stand-by Current	: Less than 0.1 μA
Protection Circuits	: Current Limit 350mA TYP, Foldback Overheat Protection $T_{TSB}=150^\circ\text{C}$
Output Capacitor	: Ceramic Capacitor Compatible
Built-in Function	: C_L High-Speed Discharge
Operating Ambient Temperature	: $-40^\circ\text{C} \sim 85^\circ\text{C}$
Packages	: SOT-25, SOT-89-5, USP-6C
Environmentally Friendly	: EU RoHS Compliant, Pb Free

TYPICAL APPLICATION CIRCUIT

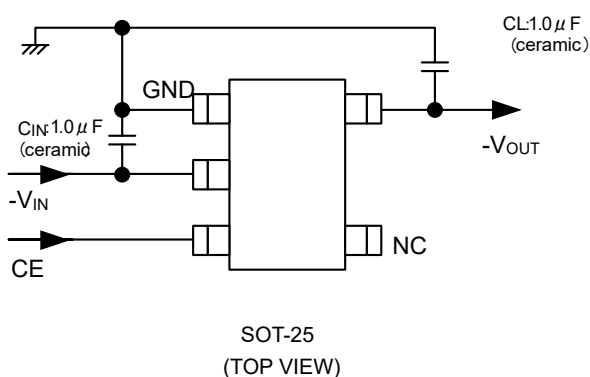

TYPICAL PERFORMANCE CHARACTERISTICS

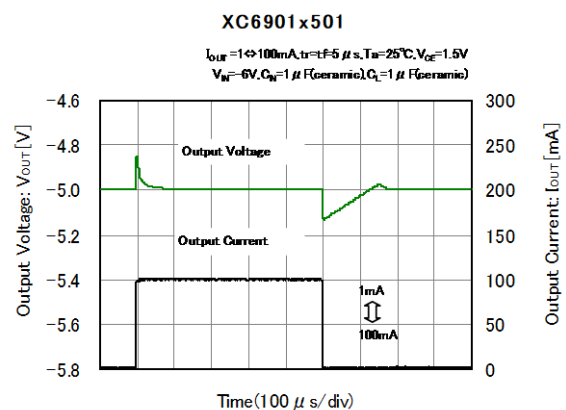

■ PIN CONFIGURATION

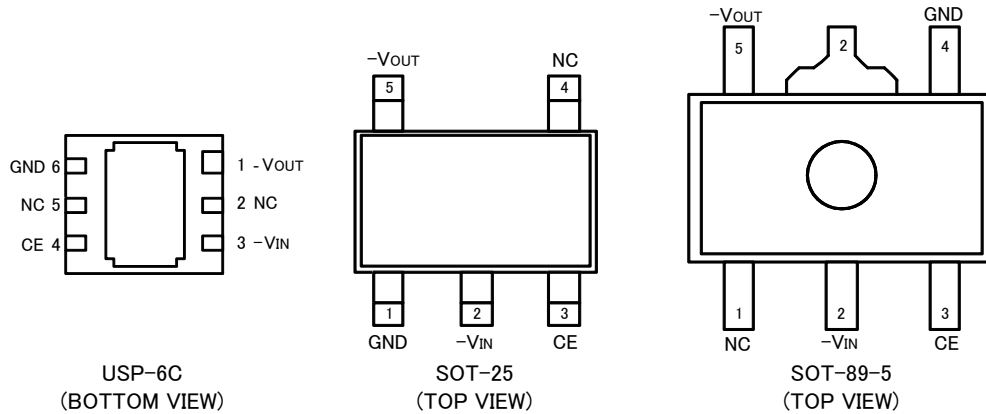

* The dissipation pad for the USP-6C package should be solder-plated in recommended mount pattern and metal masking to enhance mounting strength and heat release. If the pad needs to be connected to other pins, it should be connected to the -V_{IN} (No. 3) pin.

■ PIN ASSIGNMENT

PIN NUMBER			PIN NAME	FUNCTIONS
USP-6C	SOT-25	SOT-89-5		
1	5	5	-V _{OUT}	Negative Output
2,5	4	1	NC	No Connection
3	2	2	-V _{IN}	Negative Supply Input
4	3	3	CE	ON/OFF Control
6	1	4	GND	Ground

■ FUNCTION CHART

PIN NAME	SIGNAL	STATUS
CE	L	Stand-by
	H	Active
	OPEN	Stand-by

■ PRODUCT CLASSIFICATION

● Ordering Information

XC6901①②③④⑤⑥-⑦^(*) ON/OFF Control Voltage Regulator (CE Active High)

DESIGNATOR	ITEM	SYMBOL	DESCRIPTION
①	Type ⁽²⁾	D	CE Pull-down resistor C _L Auto-discharge
②③	Output Voltage	09~C0	-0.9V~-12V e.g. -0.9V→②=0, ③=9, -12V→②=C, ③=0 A: 10, B: 11, C: 12
④	Output Type	1	0.10V Increments e.g. -1.2V→②=1, ③=2, ④=1
		B	0.05V Increments for -0.95V~-4.95V e.g. -1.25V→②=1, ③=2, ④=B
⑤⑥-⑦	Packages (Order Unit)	ER-G	USP-6C (3,000/Reel)
		MR-G	SOT-25 (3,000/Reel)
		PR-G	SOT-89-5 (1,000/Reel)

^(*) The "-G" suffix denotes Halogen and Antimony free as well as being fully EU RoHS compliant.

⁽²⁾ For the type without C_L auto-discharge, please contact your local Torex sales office or representative.

■ STANDARD VOLTAGE

● Examples for standard voltage

V _{OUT} (V)	PACKAGES		
	USP-6C	SOT-25	SOT-89-5
-1.2V	XC6901D121ER-G	XC6901D121MR-G	XC6901D121PR-G
-2.5V	XC6901D251ER-G	XC6901D251MR-G	XC6901D251PR-G
-2.6V	XC6901D261ER-G	XC6901D261MR-G	XC6901D261PR-G
-3.0V	XC6901D301ER-G	XC6901D301MR-G	XC6901D301PR-G
-3.3V	XC6901D331ER-G	XC6901D331MR-G	XC6901D331PR-G
-4.0V	XC6901D401ER-G	XC6901D401MR-G	XC6901D401PR-G
-4.5V	XC6901D451ER-G	XC6901D451MR-G	XC6901D451PR-G
-5.0V	XC6901D501ER-G	XC6901D501MR-G	XC6901D501PR-G
-6.0V	XC6901D601ER-G	XC6901D601MR-G	XC6901D601PR-G
-12.0V	XC6901DC01ER-G	XC6901DC01MR-G	XC6901DC01PR-G

■ ABSOLUTE MAXIMUM RATINGS

GND=0V, Ta=25°C

PARAMETER		SYMBOL	RATINGS	UNITS
Input Voltage		V_{IN}	GND-18+ V_{CE} ~ GND+0.3	V
Output Current		I_{OUT}	500 ^(*1)	mA
Output Voltage		V_{OUT}	- V_{IN} -0.3 ~ GND+0.3	V
CE Input Voltage		V_{CE}	GND-0.3 ~ V_{IN} +18	V
Power Dissipation	USP-6C	P_d	120	mW
			1000 (PCB mounted) ^(*2)	
	SOT-25		250	
			600 (PCB mounted) ^(*2)	
	SOT-89-5		500	
Operating Ambient Temperature		T_{opr}	-40 ~ 85	°C
Storage Temperature		T_{stg}	-55 ~ 125	°C

(*1): Please use within the range of $I_{OUT} \leq P_d / (V_{OUT} - V_{IN})$

(*2) The power dissipation figure shown is PCB mounted and is for reference only.

■ BLOCK DIAGRAM

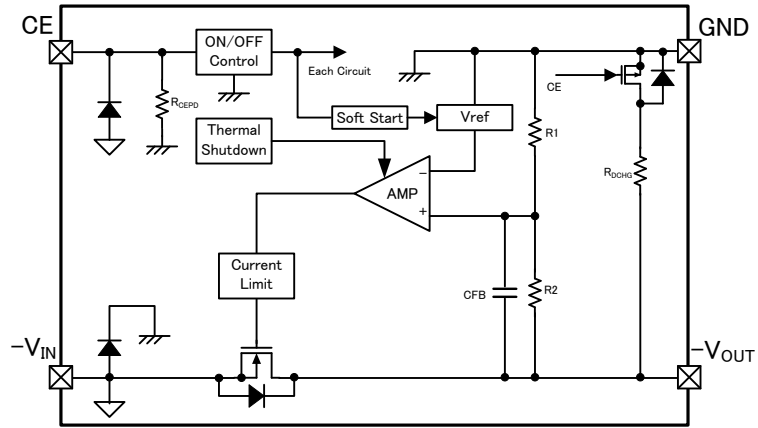

*Diodes inside the circuit are an ESD protection diode and a parasitic diode.

ELECTRICAL CHARACTERISTICS

●XC6901 Series

GND=0V, Ta=25°C

PARAMETER	SYMBOL	CONDITIONS		MIN.	TYP.	MAX.	UNITS	CIRCUIT
Output Voltage	$V_{OUT(E)}$ ⁽²⁾	$I_{OUT}=20mA$	$V_{OUT(T)} < -2.0V$	×1.015	$V_{OUT(T)}$ ⁽¹⁾	×0.985	V	①
			$V_{OUT(T)} \geq -2.0V$	-0.030		+0.030		
Maximum Output Current ⁽⁴⁾	I_{OUTMAX}	$V_{IN}=V_{OUT(T)}-2.0V$	$V_{OUT(T)} \leq -2.4V$	200	-	-	mA	①
		$V_{IN}=-4.4V$	$V_{OUT(T)} > -2.4V$					
Load Regulation	ΔV_{OUT}	$V_{IN}=V_{OUT(T)}-1.0V$	$V_{OUT(T)} \leq -3.0V$	-	20	60	mV	①
		$V_{IN}=-4.0V$	$V_{OUT(T)} > -3.0V$					
		$1mA \leq I_{OUT} \leq 100mA$						
Dropout Voltage	V_{dif} ⁽³⁾	$I_{OUT}=20mA$		-	E-1 ⁽⁵⁾		mV	①
Supply Current	I_{BIAS}	$V_{IN}=-14.5V, V_{CE}=1.5V, I_{OUT}=0mA$		-	100	200	μA	①
Stand-by Current	I_{STB}	$V_{IN}=-14.5V, V_{CE}=0V, I_{OUT}=0mA$		-	0.01	0.1	μA	①
Input Line Regulation	$\frac{\Delta V_{OUT}}{(\Delta V_{IN} \cdot V_{OUT})}$	$-14.5V \sim V_{OUT(T)}-1V$	$V_{OUT(T)} \leq -1.4V$	-	0.01	0.20	%V	①
		$-14.5V \sim -2.4V$	$V_{OUT(T)} > -1.4V$					
		$I_{OUT}=20mA$						
Input Voltage	V_{IN}			$-16 + V_{CE}$	-	-2.4	V	①
Output Voltage Temperature Characteristics	$\frac{\Delta V_{OUT}}{(\Delta T_{opr} \cdot V_{OUT})}$	$I_{OUT}=20mA$ $-40^\circ C \leq T_{opr} \leq 85^\circ C$		-	±50	-	ppm/°C	①
Power Supply Rejection Ratio	PSRR	$V_{IN} = \{V_{OUT(T)} - 1.0V\} + 0.5V_{pp-pAC}$, $I_{OUT}=20mA, f=1kHz$		-	45	-	dB	②
Limit Current	I_{LIM}	$V_{IN}=V_{OUT(T)}-2.0V$	$V_{OUT(T)} \leq -2.4V$	210	300	-	mA	①
		$V_{IN}=-4.4V$	$V_{OUT(T)} > -2.4V$					
Short-Circuit Current	I_{SHORT}	$V_{IN}=V_{OUT(T)}-2.0V$ Short - V_{OUT} to GND level		-	80	-	mA	①
Detect Thermal Shutdown Temperature	T_{TSD}	IC Junction temperature		-	150	-	°C	①
Release Thermal Shutdown Temperature	T_{TSR}	IC Junction temperature		-	125	-	°C	①
Hysteresis Width	T_{HYS}	$T_{TSD} - T_{TSR}$		-	25	-	°C	①
CE "H" Level Voltage	V_{CEH}			1.2	-	3.6	V	①
CE "L" Level Voltage	V_{CEL}			GND	-	0.4	V	①
CE "H" Level Current	I_{CEH}	$V_{IN}=-12.4V$, $V_{CE}=3.6V$	XC6901D Series	1.8	4	7	μA	①
CE "L" Level Current	I_{CEL}	$V_{CE}=GND$		-0.1	-	0.1	μA	①
C_L Discharge Resistor	R_{DCHG}	$V_{IN}=-8V, V_{OUT}=-2V, V_{CE}=GND$		0.7	1.2	1.8	kΩ	①
Soft Start Time	t_{SS}	$R_L=3k\Omega$, Rise Time CE="H" to 95% of $V_{OUT(E)}$	$V_{OUT(T)} > -4.0V$	0.15	0.4	1.2	ms	③
			$V_{OUT(T)} \leq -4.0V$	0.3	0.7	2	ms	③

NOTE: Unless otherwise stated regarding input voltage conditions $V_{CE}=1.5V$, $GND=0V$, $V_{IN}=V_{OUT(T)}-1.0V$ or $-2.4V$ the one which bigger absolute value.

*1) $V_{OUT(T)}$: Nominal output voltage

*2) $V_{OUT(E)}$: Effective output voltage (see the voltage chart)

(ie. The output voltage when " $V_{OUT(T)}-1.0V$ " or " $-2.4V$ " is provided at the V_{IN} pin while maintaining a certain I_{OUT} value.

*3) $V_{dif} = -\{V_{IN1} - V_{OUT1}\}$

V_{IN1} is the input voltage when V_{OUT1} appears at the V_{OUT} pin while input voltage is gradually increased

V_{OUT1} is the voltage equal to 98% of the normal output voltage when amply stabilized $V_{OUT(T)}-1.0V$ or $-2.4V$ (the bigger absolute value one) are input at the V_{IN} pin.

*4) The maximum current may not be able to flow when thermal shutdown operates, it depends on power dissipation.

*5) E-1: Refer to dropout voltage chart.

■ ELECTRICAL CHARACTERISTICS(Continued)

Dropout Voltage Chart ($V_{OUT(T)} = -0.9V \sim -5V$)

NOMINAL OUTPUT VOLTAGE	E-1		NOMINAL OUTPUT VOLTAGE	E-1		NOMINAL OUTPUT VOLTAGE	E-1	
	DROPOUT VOLTAGE			DROPOUT VOLTAGE			DROPOUT VOLTAGE	
	Vdif (mV)			Vdif (mV)			Vdif (mV)	
$V_{OUT(T)}$	TYP.	MAX.	$V_{OUT(T)}$	TYP.	MAX.	$V_{OUT(T)}$	TYP.	MAX.
-0.90	800	1500	-2.85	116	157	-4.80	80	115
-0.95	750	1450	-2.90	114	155	-4.85	80	115
-1.00	700	1400	-2.95	112	153	-4.90	79	115
-1.05	650	1350	-3.00	110	151	-4.95	79	115
-1.10	600	1300	-3.05	109	150	-5.00	78	114
-1.15	550	1250	-3.10	108	148			
-1.20	500	1200	-3.15	107	147			
-1.25	450	1150	-3.20	105	145			
-1.30	400	1100	-3.25	104	144			
-1.35	350	1050	-3.30	102	142			
-1.40	300	1000	-3.35	102	141			
-1.45	270	950	-3.40	101	140			
-1.50	230	900	-3.45	101	139			
-1.55	220	850	-3.50	100	137			
-1.60	210	800	-3.55	99	136			
-1.65	205	750	-3.60	98	135			
-1.70	200	700	-3.65	97	134			
-1.75	195	650	-3.70	95	133			
-1.80	190	600	-3.75	95	132			
-1.85	183	550	-3.80	94	131			
-1.90	176	500	-3.85	94	130			
-1.95	171	450	-3.90	93	129			
-2.00	165	400	-3.95	92	128			
-2.05	161	350	-4.00	91	127			
-2.10	156	300	-4.05	90	126			
-2.15	152	250	-4.10	89	125			
-2.20	148	200	-4.15	89	125			
-2.25	144	187	-4.20	88	124			
-2.30	140	185	-4.25	87	123			
-2.35	138	183	-4.30	86	122			
-2.40	135	181	-4.35	86	122			
-2.45	132	178	-4.40	85	121			
-2.50	129	174	-4.45	85	120			
-2.55	127	172	-4.50	84	119			
-2.60	125	169	-4.55	83	119			
-2.65	123	166	-4.60	82	119			
-2.70	121	163	-4.65	82	118			
-2.75	119	161	-4.70	82	117			
-2.80	117	159	-4.75	81	116			

■ ELECTRICAL CHARACTERISTICS(Continued)

Dropout Voltage Chart ($V_{OUT(T)}=-5.1V\sim-12V$)

NOMINAL OUTPUT VOLTAGE	E-1		NOMINAL OUTPUT VOLTAGE	E-1	
	DROPOUT VOLTAGE			DROPOUT VOLTAGE	
	Vdif(mV)			Vdif(mV)	
$V_{OUT(T)}$	TYP.	MAX.	$V_{OUT(T)}$	TYP.	MAX.
-5.1	77	113	-9.0	58	93
-5.2	77	112	-9.1	58	92
-5.3	76	111	-9.2	58	92
-5.4	75	110	-9.3	57	92
-5.5	74	110	-9.4	57	91
-5.6	73	109	-9.5	56	91
-5.7	73	108	-9.6	56	91
-5.8	72	107	-9.7	56	91
-5.9	71	106	-9.8	55	90
-6.0	70	105	-9.9	55	90
-6.1	70	105	-10.0	54	90
-6.2	69	104	-10.1	54	90
-6.3	69	104	-10.2	54	89
-6.4	68	103	-10.3	54	89
-6.5	67	102	-10.4	54	89
-6.6	66	102	-10.5	53	88
-6.7	66	101	-10.6	53	88
-6.8	65	101	-10.7	53	88
-6.9	65	100	-10.8	53	88
-7.0	65	100	-10.9	53	88
-7.1	64	99	-11.0	52	88
-7.2	64	99	-11.1	53	88
-7.3	63	98	-11.2	52	87
-7.4	63	98	-11.3	51	87
-7.5	62	98	-11.4	51	87
-7.6	62	98	-11.5	50	87
-7.7	62	97	-11.6	50	87
-7.8	61	96	-11.7	50	87
-7.9	61	96	-11.8	50	87
-8.0	60	96	-11.9	50	87
-8.1	60	96	-12.0	50	87
-8.2	60	95			
-8.3	60	95			
-8.4	60	94			
-8.5	59	94			
-8.6	59	94			
-8.7	59	94			
-8.8	59	93			
-8.9	59	93			

TEST CIRCUITS

1) CIRCUIT①

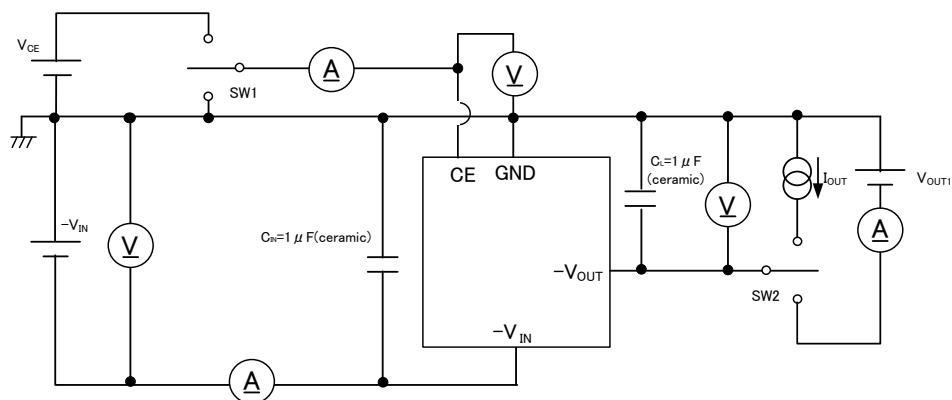

2) CIRCUIT②

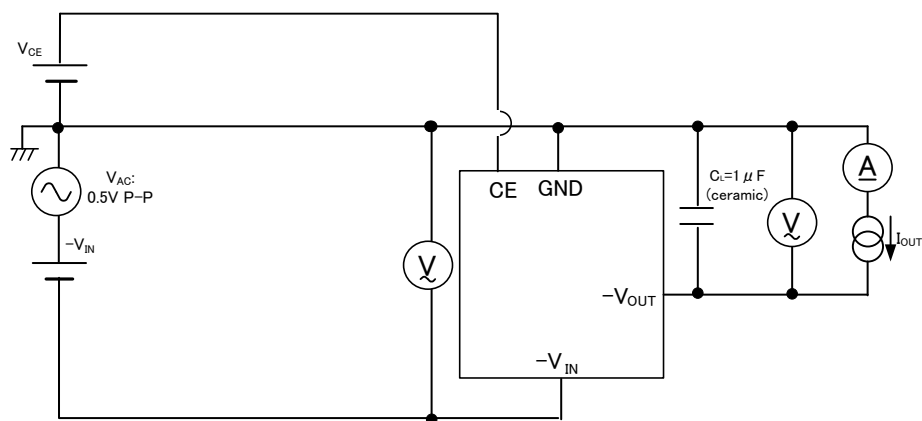

3) CIRCUIT③

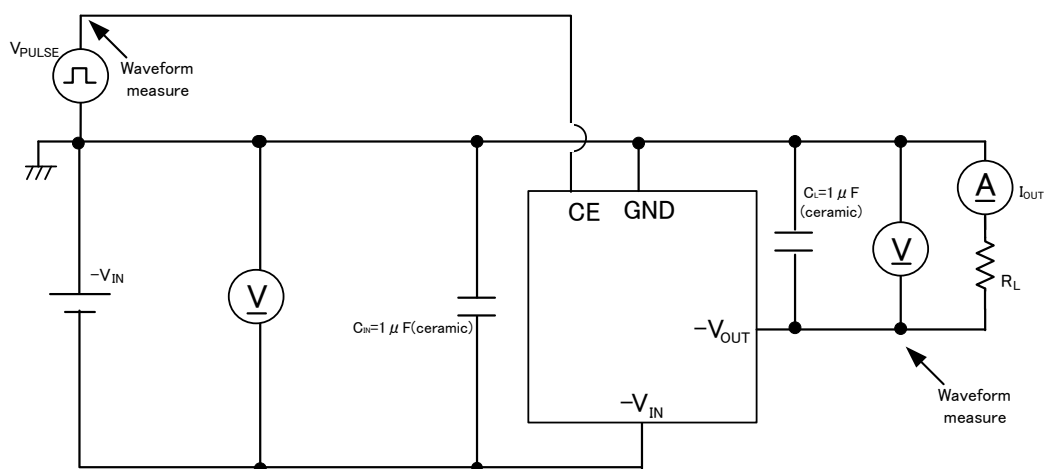

OPERATIONAL EXPLANATION

The voltage divided by resistors R1 and R2 is compared with the internal reference voltage based on ground by the error amplifier. The driver transistor tied to the $-V_{IN}$ pin is then driven by the subsequent output signal. The output voltage at the $-V_{OUT}$ pin is controlled and stabilized by a system of negative feedback.

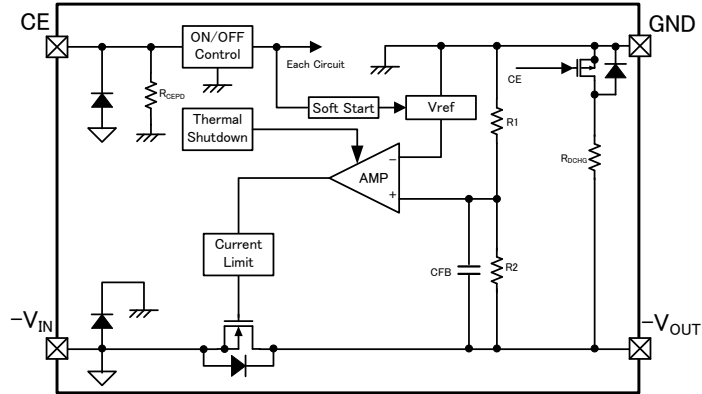

<Soft Start Function>

XC6901 Series includes soft-start circuit. During power start-up, the inrush current from $-V_{IN}$ pin to V_{OUT} pin to charge C_L capacitor can be reduced and it makes the V_{IN} stable. Soft-start time (t_{SS}) is optimized internally.

Figure1 : Soft Start Time and Inrush Current

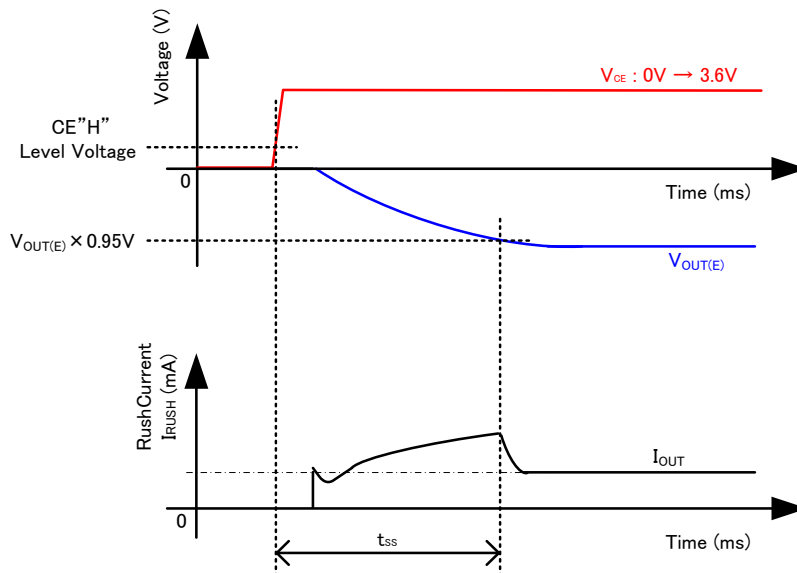

■ OPERATIONAL EXPLANATION(Continued)

<Current Limit, Short-Circuit Protection>

The XC6901 series' fold-back circuit operates as an output current limiter and a short protection circuit for the output pin. When the output current reaches the current limit level, output voltage drops with the decrease of the output current. There are no parasitic diode between the $-V_{OUT}$ pin and GND pin. The minimized short-circuit current is maintained even if the $-V_{OUT}$ pin voltage is pulled up toward positive.

<Thermal Shutdown>

The XC6901 Series has an internal thermal Shutdown(TSD) circuit for protection against overheating. When the junction temperature reaches the detection temperature, the driver transistor is forcibly turned off. When the junction temperature falls to the release temperature with the driver transistor still in the off state, the driver transistor turns on (automatic recovery) and restarts regulator operation.

<CE Pin>

The XC6901 Series is able to shut down the regulator circuit using the CE pin signal. CE pin can be controlled with positive voltage due to P-channel transistor source input (Gate is grounded). A current flow of a few micro amperes. The regulator is turned on when CE input voltage is positive, the regulator is turned off when CE input is GND.

When CE pin is open, IC is turned OFF, due to the built-in Pull-down resistor. When the IC is turned OFF with low input voltage to the CE pin, $-V_{OUT}$ pin voltage goes into GND level by R1,R2 and CL discharge resistance(R_{DCHG}).

OPERATIONAL EXPLANATION(Continued)

<C_L High Speed Discharge>

The XC6901D type is capable of high-speed discharge of the charge that collects on the output capacitor (C_L below). This is accomplished by the P-channel MOSFET and C_L discharge resistance connected between the -V_{OUT} and GND pins in the block diagram, and takes place when the L-level signal (IC internal circuit shutdown signal) of the CE pin is input so that it could avoid malfunction.

The C_L discharge time is determined by this C_L discharge resistance and C_L. Letting the time constant of the C_L discharge resistance R_{DCHG} and C_L be τ ($\tau = C \times R$), the output voltage after discharge by the P-channel MOSFET can be obtained from the CR discharge equation below. Please be noted that R_{DCHG} varies with supply voltage and V_{DS}(drain-source voltage) since it consists of P-channel MOSFET.

$$t = \tau \ln(V_{OUT(E)} / V)$$

V: Output voltage during discharge
V_{OUT(E)}: Output voltage
t: Discharge time
 τ : C_L auto-discharge resistance R_{DCHG} × C_L Output capacitor value C_L

<Low ESR Capacitor>

With the XC6901 series, a stable output voltage is achievable even if used with low ESR capacitors, as a phase compensation circuit is built-in. The output capacitor (C_L) should be connected as close to -V_{OUT} pin and GND pin to obtain stable phase compensation. Values required for the phase compensation are as the table below.

For a stable power input, please connect an input capacitor (C_{IN}) near power supply. In order to ensure the stable phase compensation while avoiding run-out of values, please use the capacitor (C_{IN}, C_L) which does not depend on bias or temperature too much. The table below shows recommended values of C_{IN}, C_L for all environment conditions.

CHART 1 : Recommended Values of C_{IN}, C_L (MIN.)

OUTPUT VOLTAGE RANGE	INPUT CAPACITOR	OUTPUT CAPACITOR
V _{OUT(T)}	C _{IN}	C _L
-0.9V~-12V	1.0 μF~	1.0 μF~100 μF

NOTE ON USE

- 1) For temporary, transitional voltage drop or voltage rising phenomenon. The IC is liable to malfunction should the ratings be exceeded.
- 2) Where wiring impedance is high, operations may become unstable due to noise and/or phase lag depending on output current. Please enforce wiring -V_{IN} and GND.
- 3) Please wire the C_{IN} and C_L as close to the IC as possible.
- 4) Capacitances of these capacitors (C_{IN}, C_L) are decreased by the influences of bias voltage and ambient temperature. Care shall be taken for capacitor selection to ensure stability of phase compensation from the point of ESR influence.
- 5) Torex places an importance on improving our products and its reliability. However, by any possibility, we would request user fail-safe design and post-aging treatment on system or equipment.

TYPICAL PERFORMANCE CHARACTERISTICS

(1) Output Voltage vs. Output Current

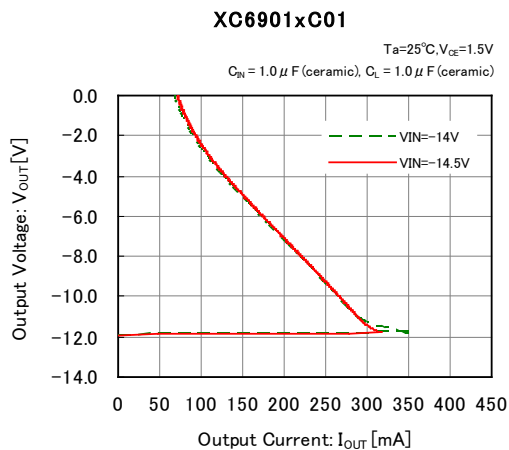
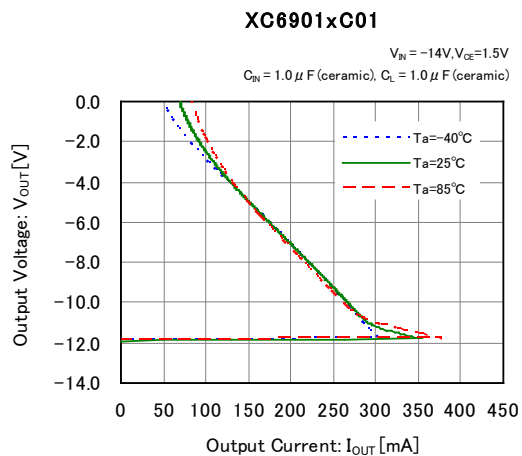
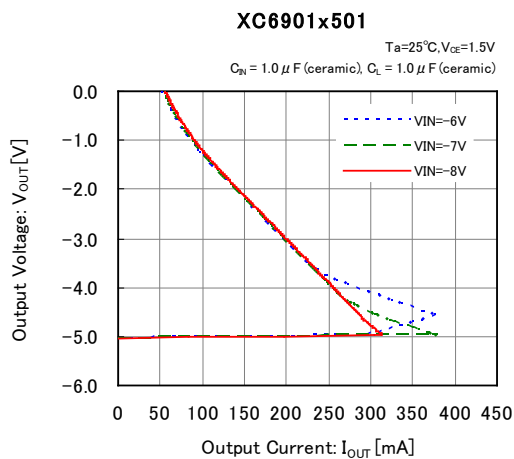
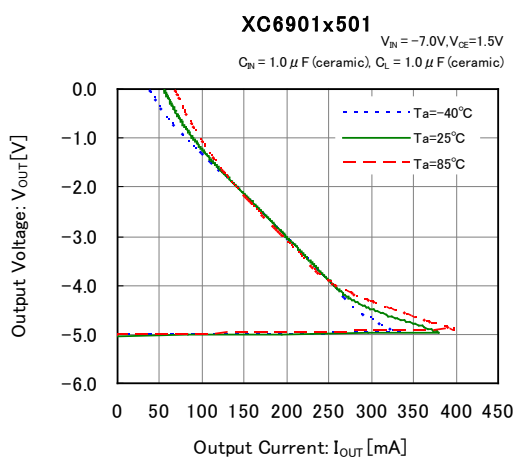
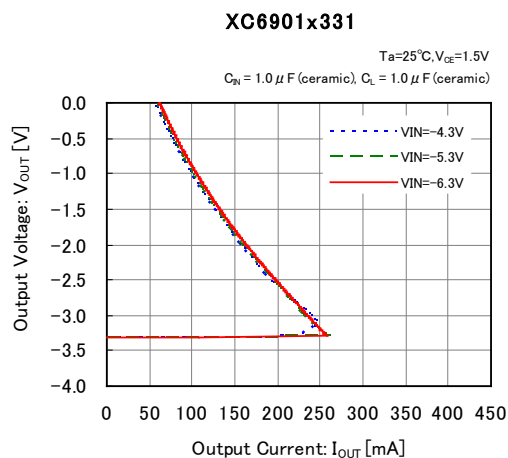
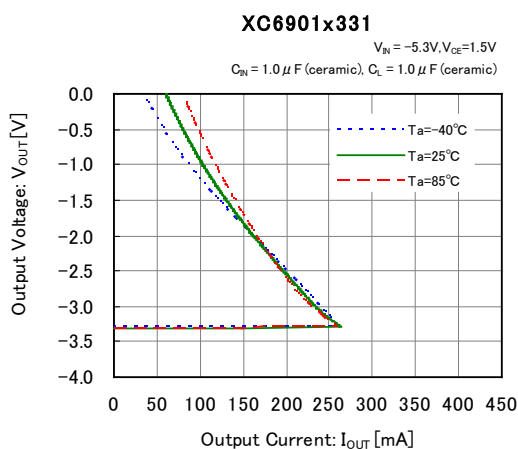

TYPICAL PERFORMANCE CHARACTERISTICS (Continued)

(2) Output Voltage vs. Input Voltage

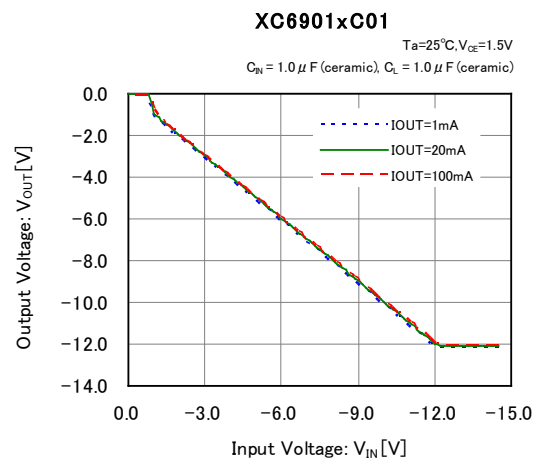
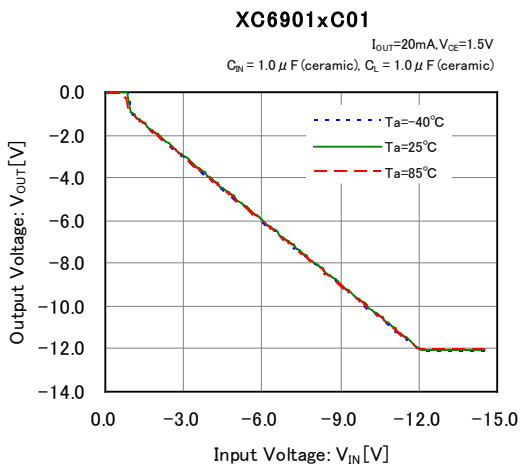
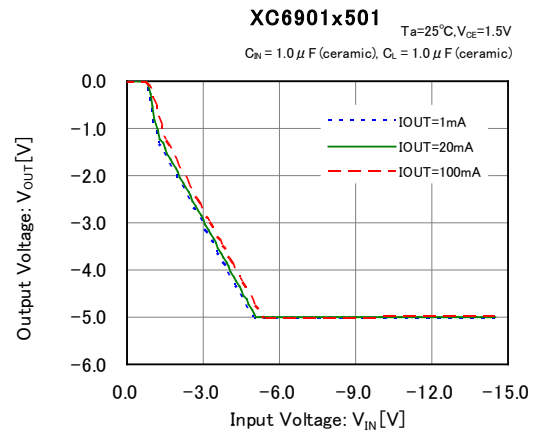
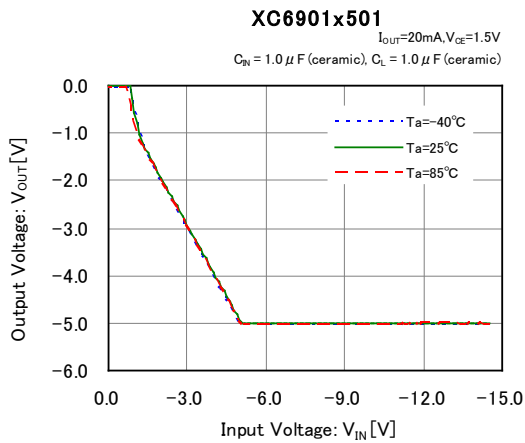
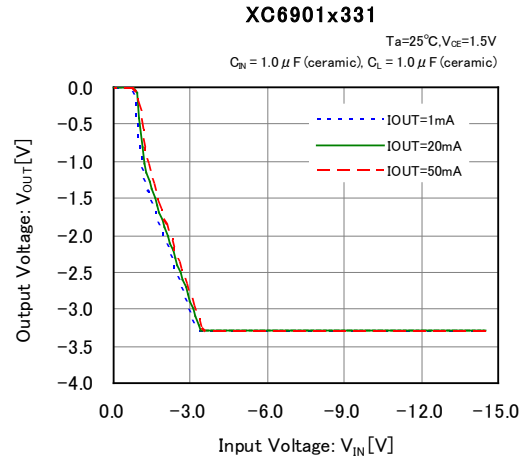
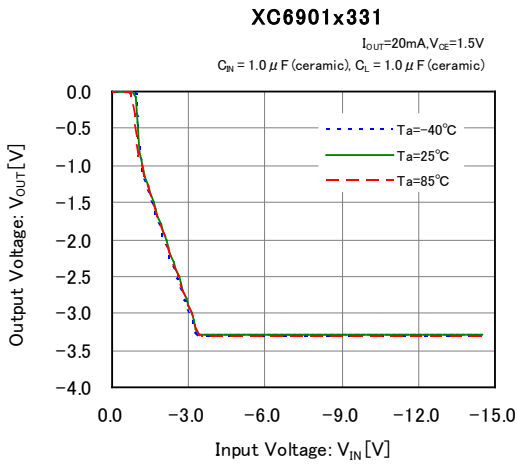

TYPICAL PERFORMANCE CHARACTERISTICS (Continued)

(3) Dropout Voltage vs. Output Current

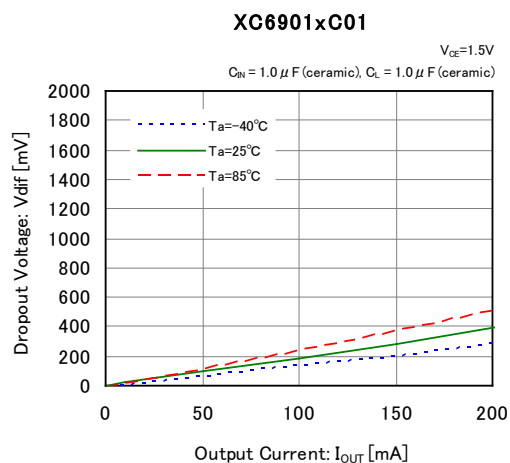
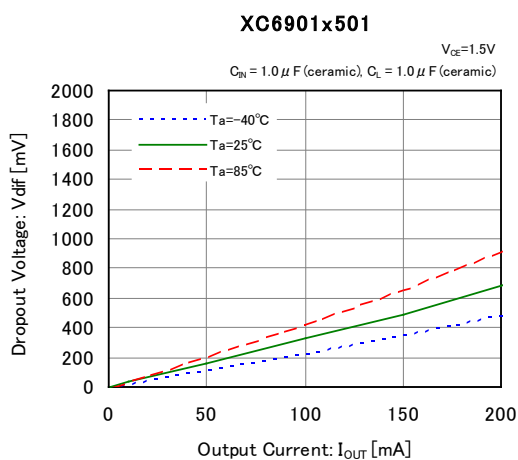
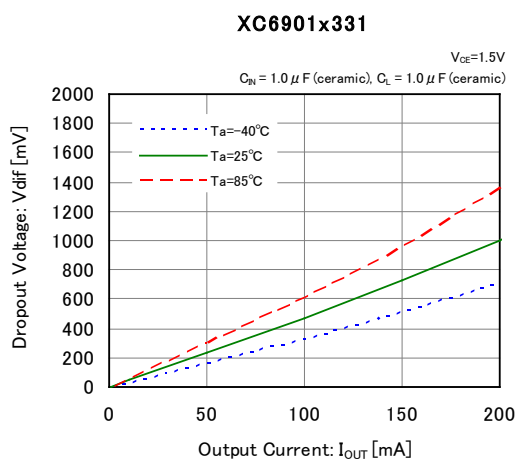

(4) Supply Current vs. Input Voltage

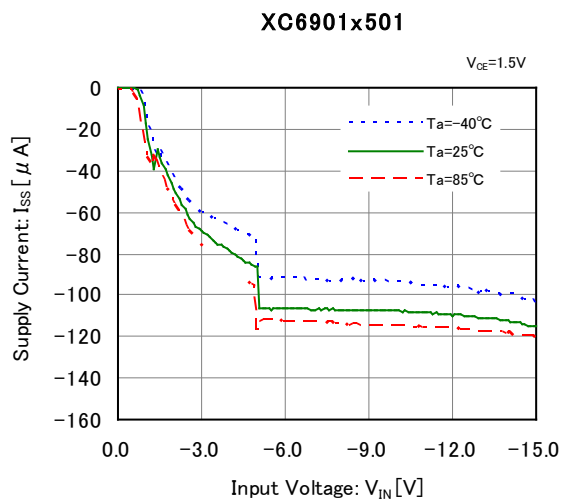
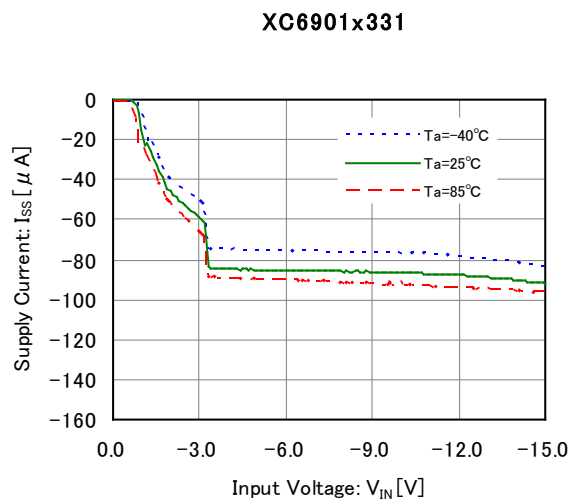

TYPICAL PERFORMANCE CHARACTERISTICS (Continued)

(4) Supply Current vs. Input Voltage (Continued)

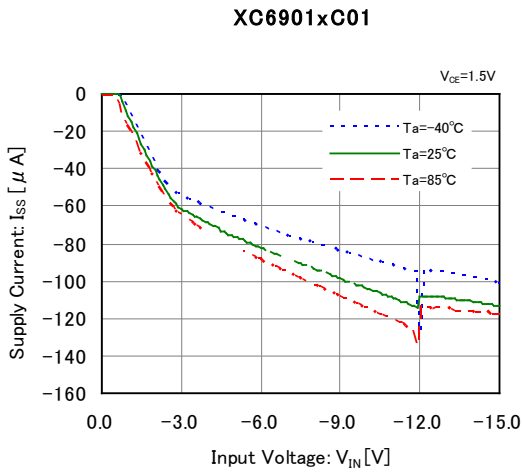

(5) Output Voltage vs. Ambient Temperature

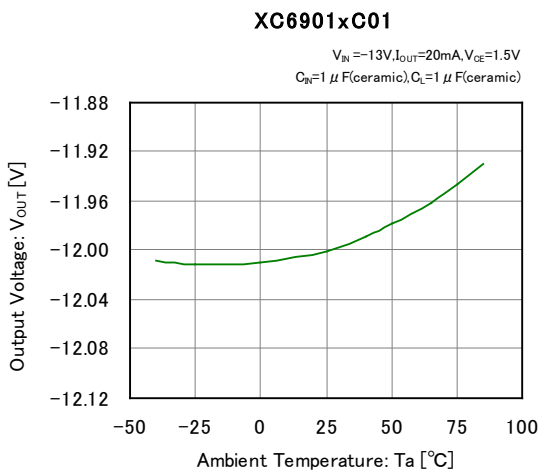
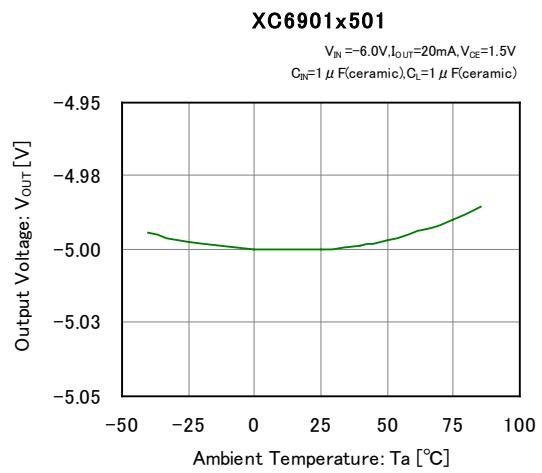
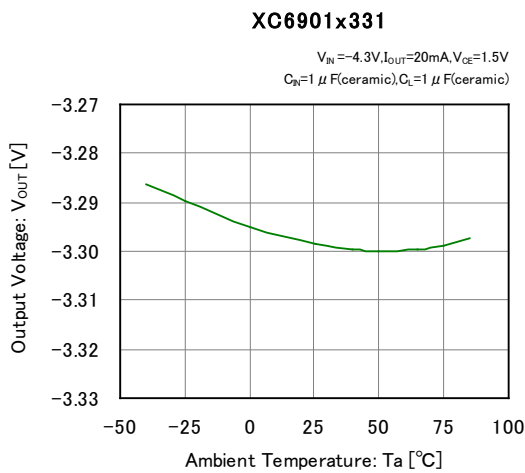

■ TYPICAL PERFORMANCE CHARACTERISTICS (Continued)

(6) CE Pin Threshold Voltage vs Ambient Temperature

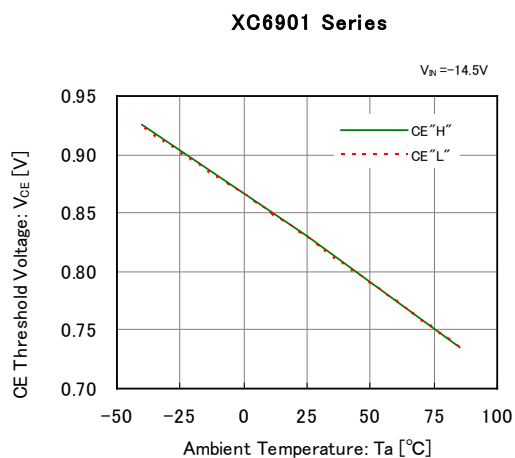

(7) CE Input Current vs CE Voltage

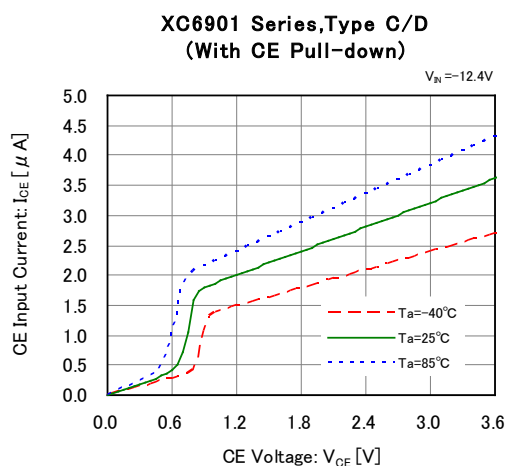
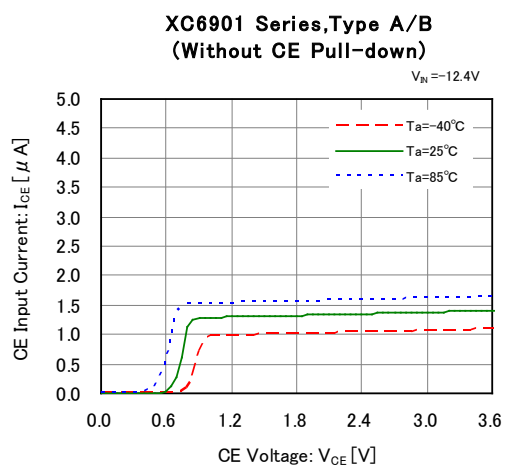

(8) CE Input Current vs Ambient Temperature

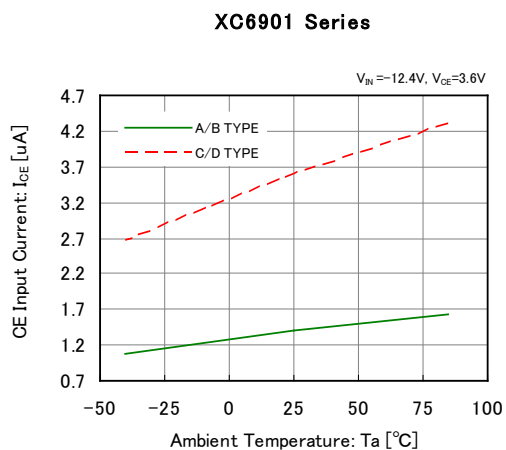

TYPICAL PERFORMANCE CHARACTERISTICS (Continued)

(9) Input Rising Response Time

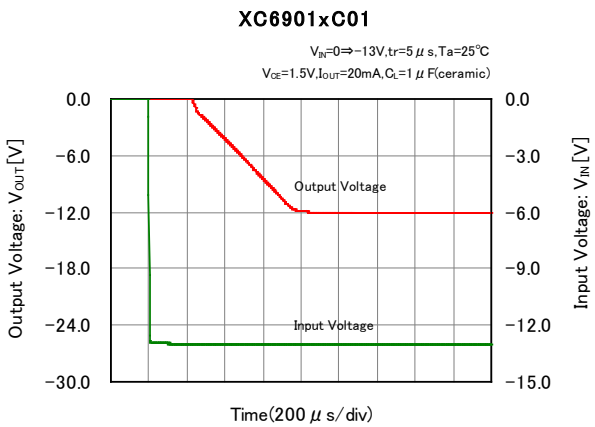
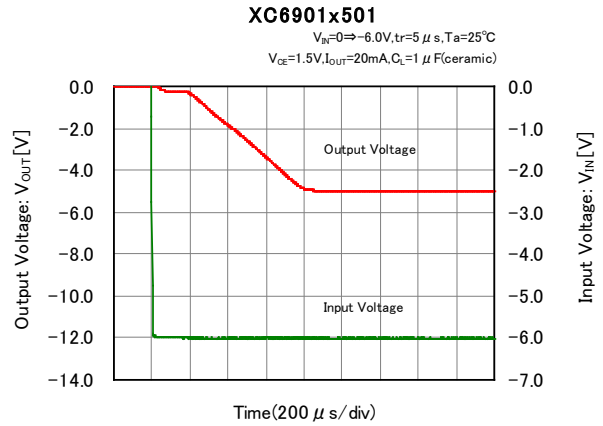
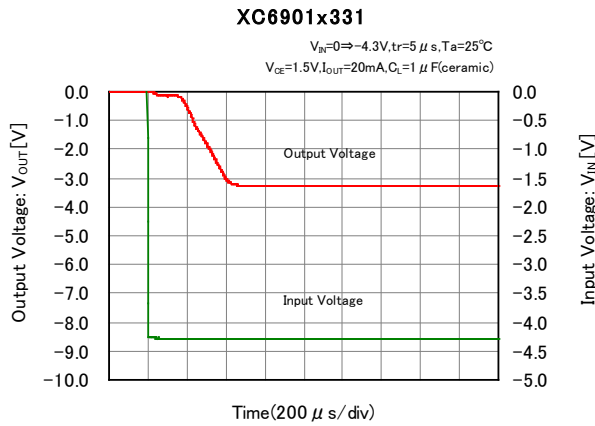

(10) CE Rising Response Time

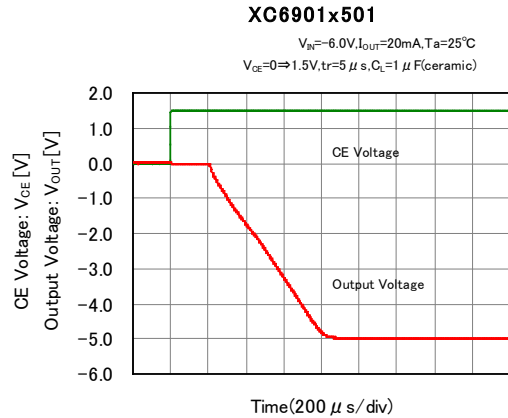
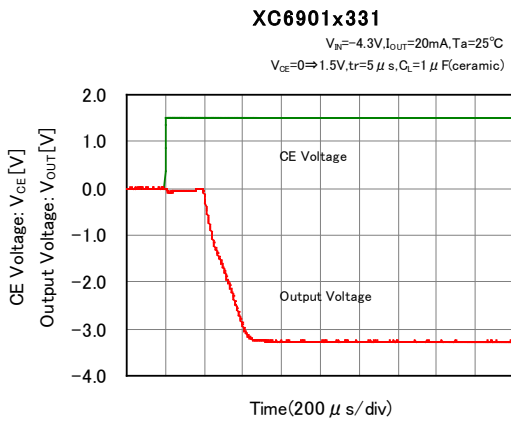

■ TYPICAL PERFORMANCE CHARACTERISTICS (Continued)

(10) CE Rising Response Time (Continued)

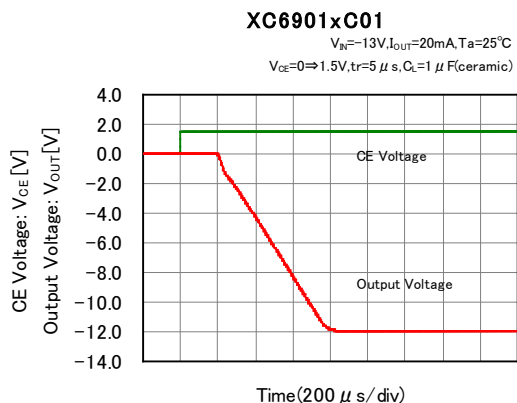

(11) Input Transient Response

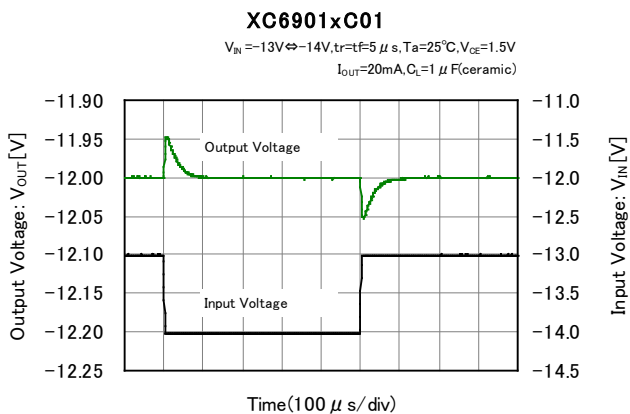
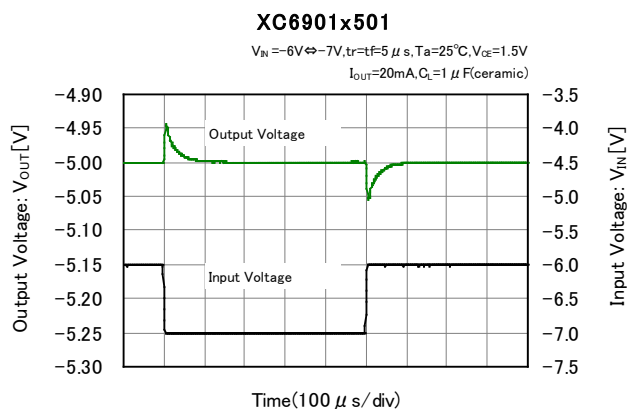
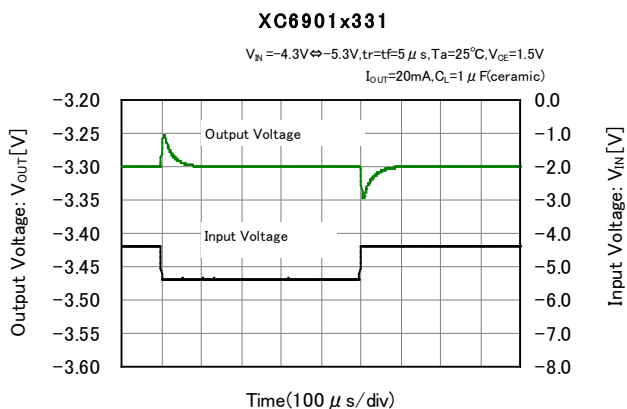

TYPICAL PERFORMANCE CHARACTERISTICS (Continued)

(12) Load Transient Response

XC6901x331

$I_{OUT} = 1 \leftrightarrow 100\text{mA}$, $t_r = t_f = 5 \mu\text{s}$, $T_a = 25^\circ\text{C}$, $V_{CE} = 1.5\text{V}$
 $V_N = -4.3\text{V}$, $C_N = 1 \mu\text{F}$ (ceramic), $C_L = 1 \mu\text{F}$ (ceramic)

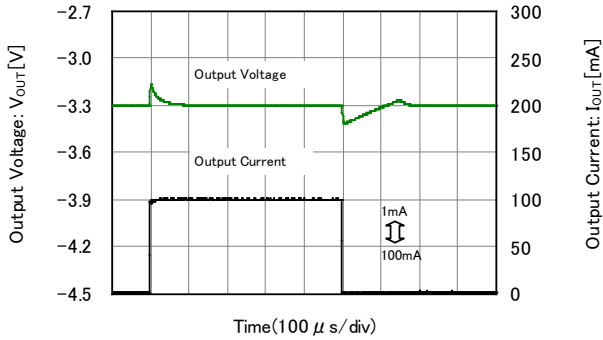

XC6901x501

$I_{OUT} = 1 \leftrightarrow 100\text{mA}$, $t_r = t_f = 5 \mu\text{s}$, $T_a = 25^\circ\text{C}$, $V_{CE} = 1.5\text{V}$
 $V_N = -6\text{V}$, $C_N = 1 \mu\text{F}$ (ceramic), $C_L = 1 \mu\text{F}$ (ceramic)

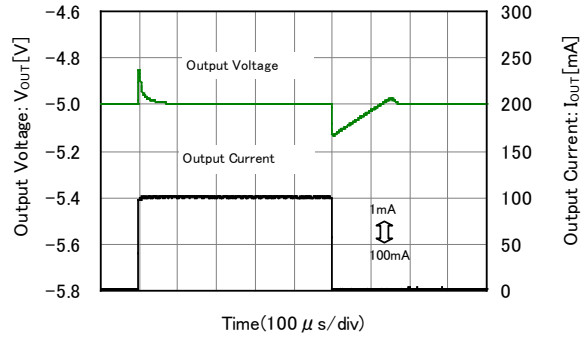

XC6901xC01

$I_{OUT} = 1 \leftrightarrow 100\text{mA}$, $t_r = t_f = 5 \mu\text{s}$, $T_a = 25^\circ\text{C}$, $V_{CE} = 1.5\text{V}$
 $V_N = -13\text{V}$, $C_N = 1 \mu\text{F}$ (ceramic), $C_L = 1 \mu\text{F}$ (ceramic)

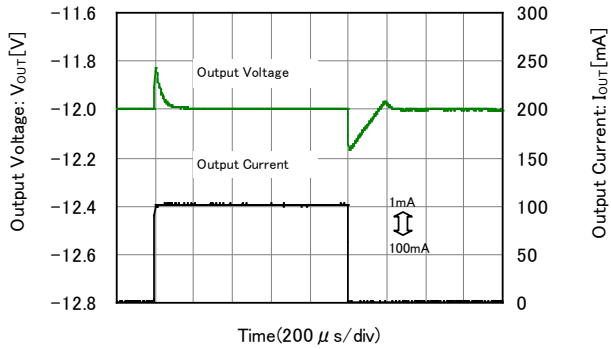

(13) Ripple Rejection Rate

XC6901x331

$T_a = 25^\circ\text{C}$, $V_N = -4.3\text{V} + 0.5V_{P-PAC}$
 $V_{CE} = 1.5\text{V}$, $C_L = 1 \mu\text{F}$ (ceramic)

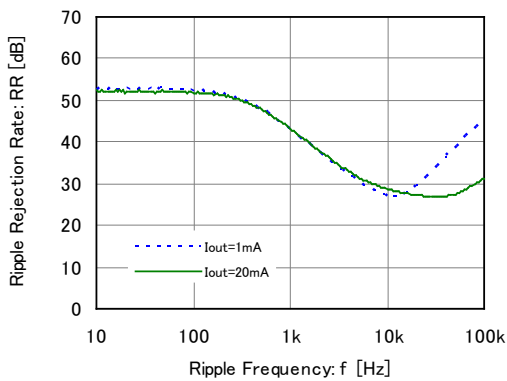

XC6901x501

$T_a = 25^\circ\text{C}$, $V_N = -6\text{V} + 0.5V_{P-PAC}$
 $V_{CE} = 1.5\text{V}$, $C_L = 1 \mu\text{F}$ (ceramic)

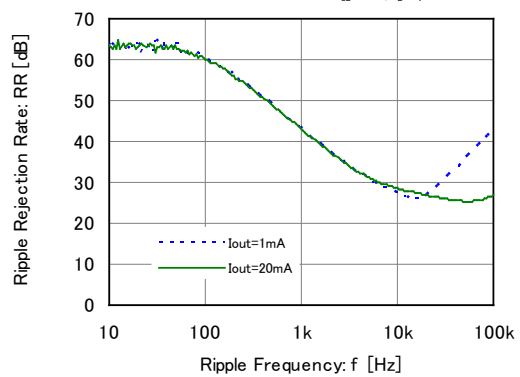

TYPICAL PERFORMANCE CHARACTERISTICS (Continued)

(13) Ripple Rejection Rate (Continued)

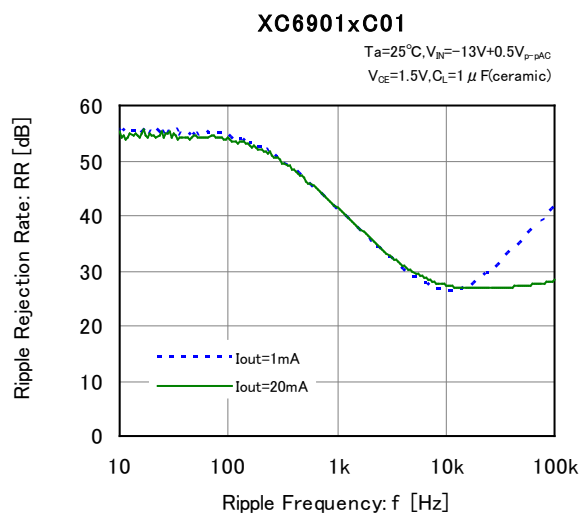

■ PACKAGING INFORMATION

For the latest package information go to, www.torexsemi.com/technical-support/packages

PACKAGE	OUTLINE / LAND PATTERN	THERMAL CHARACTERISTICS
SOT-25	SOT-25 PKG	SOT-25 Power Dissipation
SOT-89-5	SOT-89-5 PKG	SOT-89-5 Power Dissipation
USP-6C	USP-6C PKG	USP-6C Power Dissipation

MARKING RULE

SOT-25(Under dot)

※A dot is marked below the mark of ①

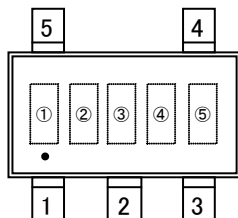

SOT89-5

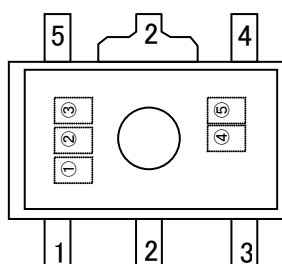

USP-6C

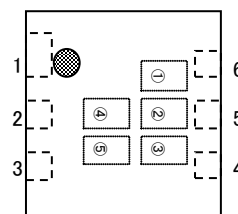

① represents product series

MARK	PRODUCT SERIES
F	XC6901*****-G

② represents output voltage range and product types

MARK	OUTPUT VOLTAGE (V)	TYPE	PRODUCT SERIES
R	-0.9 ~ -3.8	D	XC6901D091**-G ~ XC6901D381**-G
S	-3.9 ~ -6.8		XC6901D391**-G ~ XC6901D681**-G
T	-6.9 ~ -9.8		XC6901D691**-G ~ XC6901D981**-G
U	-9.9 ~ -12.0		XC6901D991**-G ~ XC6901DC01**-G

MARK	OUTPUT VOLTAGE(V)				MARK	OUTPUT VOLTAGE(V)				MARK	OUTPUT VOLTAGE(V)			
0	-0.9	-3.9	-6.9	-9.9	A	-1.9	-4.9	-7.9	-10.9	N	-2.9	-5.9	-8.9	-11.9
1	-1.0	-4.0	-7.0	-10.0	B	-2.0	-5.0	-8.0	-11.0	P	-3.0	-6.0	-9.0	-12.0
2	-1.1	-4.1	-7.1	-10.1	C	-2.1	-5.1	-8.1	-11.1	R	-3.1	-6.1	-9.1	-
3	-1.2	-4.2	-7.2	-10.2	D	-2.2	-5.2	-8.2	-11.2	S	-3.2	-6.2	-9.2	-
4	-1.3	-4.3	-7.3	-10.3	E	-2.3	-5.3	-8.3	-11.3	T	-3.3	-6.3	-9.3	-
5	-1.4	-4.4	-7.4	-10.4	F	-2.4	-5.4	-8.4	-11.4	U	-3.4	-6.4	-9.4	-
6	-1.5	-4.5	-7.5	-10.5	H	-2.5	-5.5	-8.5	-11.5	V	-3.5	-6.5	-9.5	-
7	-1.6	-4.6	-7.6	-10.6	K	-2.6	-5.6	-8.6	-11.6	X	-3.6	-6.6	-9.6	-
8	-1.7	-4.7	-7.7	-10.7	L	-2.7	-5.7	-8.7	-11.7	Y	-3.7	-6.7	-9.7	-
9	-1.8	-4.8	-7.8	-10.8	M	-2.8	-5.8	-8.8	-11.8	Z	-3.8	-6.8	-9.8	-

1. The product and product specifications contained herein are subject to change without notice to improve performance characteristics. Consult us, or our representatives before use, to confirm that the information in this datasheet is up to date.
2. The information in this datasheet is intended to illustrate the operation and characteristics of our products. We neither make warranties or representations with respect to the accuracy or completeness of the information contained in this datasheet nor grant any license to any intellectual property rights of ours or any third party concerning with the information in this datasheet.
3. Applicable export control laws and regulations should be complied and the procedures required by such laws and regulations should also be followed, when the product or any information contained in this datasheet is exported.
4. The product is neither intended nor warranted for use in equipment of systems which require extremely high levels of quality and/or reliability and/or a malfunction or failure which may cause loss of human life, bodily injury, serious property damage including but not limited to devices or equipment used in 1) nuclear facilities, 2) aerospace industry, 3) medical facilities, 4) automobile industry and other transportation industry and 5) safety devices and safety equipment to control combustions and explosions. Do not use the product for the above use unless agreed by us in writing in advance.
5. Although we make continuous efforts to improve the quality and reliability of our products; nevertheless Semiconductors are likely to fail with a certain probability. So in order to prevent personal injury and/or property damage resulting from such failure, customers are required to incorporate adequate safety measures in their designs, such as system fail safes, redundancy and fire prevention features.
6. Our products are not designed to be Radiation-resistant.
7. Please use the product listed in this datasheet within the specified ranges.
8. We assume no responsibility for damage or loss due to abnormal use.
9. All rights reserved. No part of this datasheet may be copied or reproduced unless agreed by Torex Semiconductor Ltd in writing in advance.

TOREX SEMICONDUCTOR LTD.