

AR55 Series

Smart Programmable 32-Bit Hollow Shaft and Linear Absolute Encoder

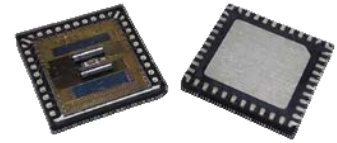

Description

The Broadcom[®] AR55 is an absolute encoder ASIC designed to meet the growing demand for large-diameter rotary and linear motion applications. Utilizing advanced reflective optical encoding technology, the AR55 series delivers high positional accuracy through a correction algorithm that magnetic encoders cannot achieve.

The AR55 encoder is a one-chip solution that supports a wide range of overall diameters, from code wheels with an outer diameter (OD) of 53 mm to linear code strips up to 8.33m in length. With larger code wheels, the AR55 supports not only blind-hollow shaft configurations but also through-hole and linear applications. User-programmable resolutions range from 1-bit to 32-bit single-turn absolute outputs. Additionally, the AR55 provides differential analog sine/cosine or digital incremental ABIUVW signals with configurable counts per revolution (CPR) and pole-pair settings. Its state-of-the-art auto-calibration feature simplifies integration into end-user systems.

The AR55 series is compatible with the Broadcom proprietary batteryless energy-harvesting multi-turn (EHMT) solution. It also supports alternative multiturn (MT) mechanisms, such as gear-based systems and battery-backed counters, via a dedicated multiturn interface port.

For power, the ASIC supports dual-mode operation at either 3.3V or 5V, making it suitable for versatile integration to a wide range of industrial applications. It operates reliably across a wide temperature range of -40°C to 125°C , ideal for most industrial environments. To enhance design flexibility, the AR55 offers a variety of user-selectable communication protocols. Supported protocols include encoder serial link (ESL), RS-485 half duplex, SSI, BiSS-C, and SPI 4-wire.

Features and Benefits

- Miniature surface-mount QFN package:
6 mm (L) × 6 mm (W) × 0.7 mm (H)
- User-programmable resolution:
 - Absolute output: 1 bit to 32 bits
 - Incremental (ABI) output: 1 CPR to 2^{26} CPR
 - Commutation signals (UVW): 1 to 32 pole pairs
- High temperature range: -40°C to 125°C
- Dual-mode operating voltage: 3.3V and 5V
- Multi-turn integration: EHMT, gear, or battery backup
- Optical radius (ROP) flexibility: blind-hollow, through-hole, or linear application
 - ROP range: 25 mm to 1335 mm
- Linear code strip pattern length: 10.2 mm to 8.33m
- Built-in line transceiver for protocol with selectable driveability strength
- Built-in calibration
 - Full-code or partial-code signal calibration
 - Accuracy calibration with constant speed rotation or with a reference encoder
- Selectable communication protocols:
 - RS-485 2.5/5/10Mb/s
 - ESL 2.5/5/10Mb/s
 - SSI 2-wire up to 10 MHz
 - SPI 4-wire up to 10 MHz
 - BiSS-C up to 10 MHz
- Up to 128 Kb of external user-accessible EEPROM memory
- Built-in temperature sensor
- RoHS compliant

Applications

- Robotics automation and engineering
- Industrial servo motor and linear actuator
- Through-shaft motor, gear motor, and speed reducer
- Factory automation and drone
- Medical and laboratory equipment

NOTE: The AR55 series encoders are not halogen-free products.

CAUTION! This product is not specifically designed or manufactured for use in any specific devices. Customers are solely responsible for determining the suitability of the product for its intended application and solely liable for all loss, damage, expense, or liability in connection with such use. Please contact Broadcom for additional information.

Functional Description

Figure 1: AR55 Block Diagram

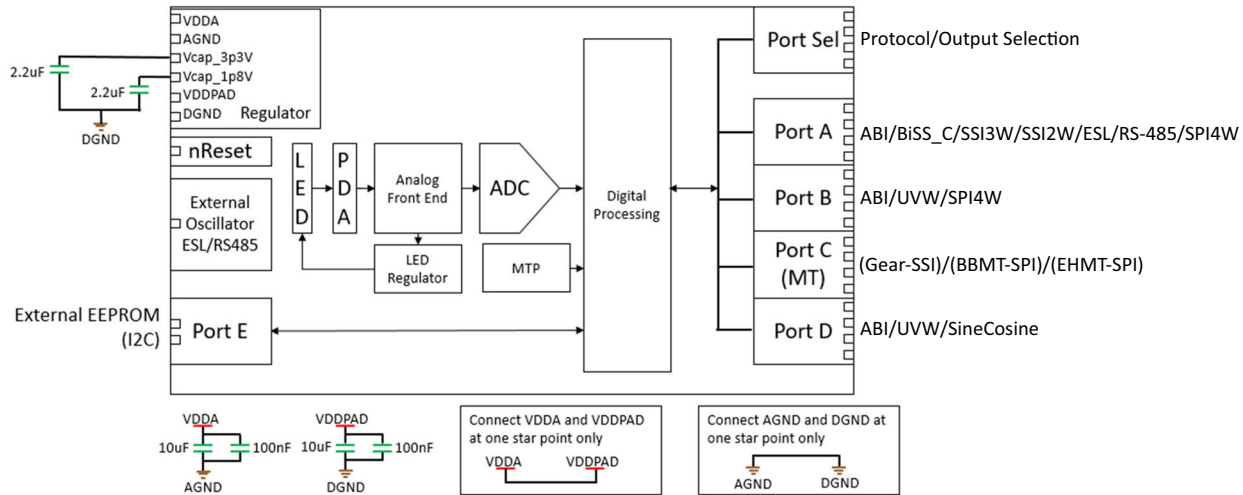
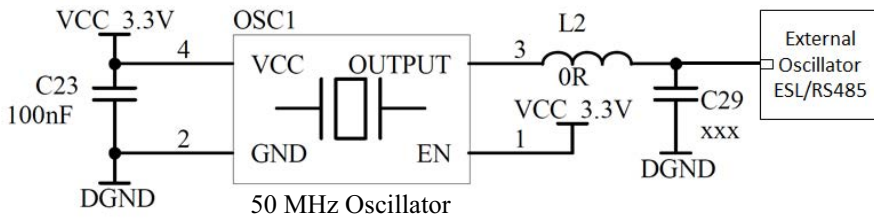

Figure 2: AR55 External Oscillator Connection Diagram



NOTE: For a 5V application, OSC1 Vcc 3.3V can be supplied from the Vcap_3p3V pin.

Figure 3: AR55 External EEPROM Connection Diagram

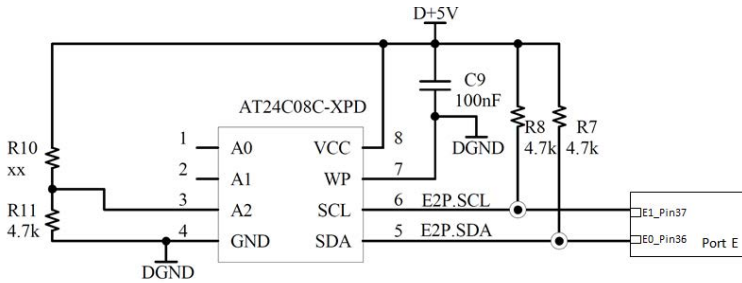
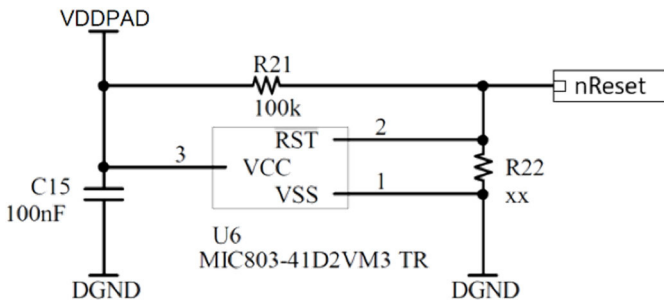

Figure 4: AR55 External nReset Connection Diagram



NOTE: For additional design details, refer to the AR55 series application note.

Selection Pins

Include capacitors at the SEL pins to prevent or eliminate any unwanted disturbance or signal coupling that could impact the operating mode selection of the AR55 encoders and lead to unwanted behavior of the encoder device.

Figure 5: Examples of High and Low Selection Circuits



Voltage Divider Circuit

Figure 6: Example of a Voltage Divider Circuit

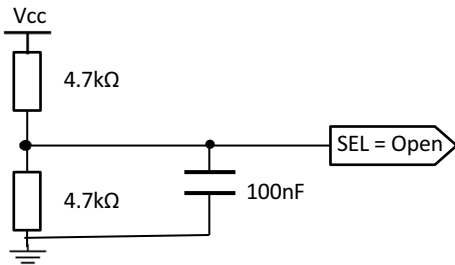

NOTE: Use two 4.7-kΩ resistors (VDDA-GND).

I/O Pins

I/O Contention

Do not apply voltage or current to the I/O pins before the AR55 encoder is powered up. There are ESD diodes and I/O multiplexing in the ASIC device pads, and any undue voltage or current going into the device can partially power up the device and bring it to an unknown state or cause an undue collection of charges prior to a proper power up. Proper power sequencing is required to ensure proper operation of the encoder device.

Output Load

The AR55 encoder is designed for a wide range of applications and as such, provides different modes of functional selections. Careful consideration of external load is required to prevent unwanted overshoot, ringing, and even instability of the device. Select a proper RC load at the output for the mode selected in the application. Do not directly drive a capacitive or inductive load.

Mechanical Specifications

Figure 7: Package Dimensions and Pinouts

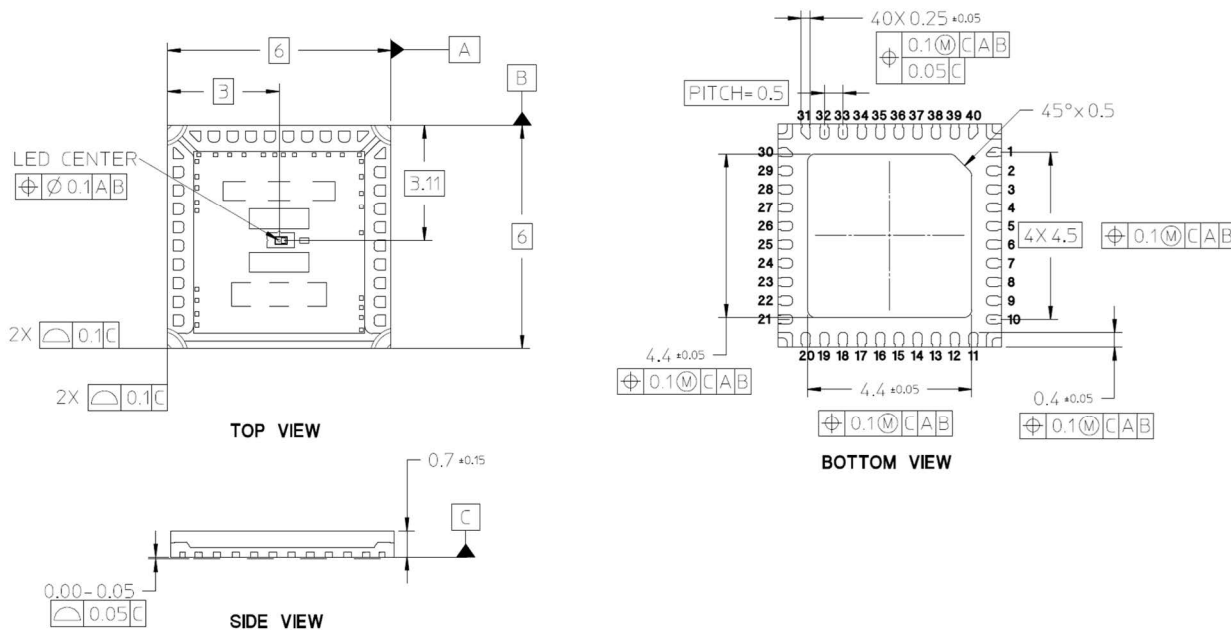

NOTE: All dimensions are in millimeters (mm).

Table 1: Pinout Descriptions

Pin	Name	Function
1	Port_B3	I/O protocol depends on Port_SEL[3:0] or internal register selection
2	Port_B2	
3	Port_B1	
4	Port_B0	
5	VDDPAD	Digital power 3.3V/5V
6	DGND	Digital ground
7	Port_A3	I/O protocol depends on Port_SEL[3:0] or internal register selection
8	Port_A2	
9	Port_A1	
10	Port_A0	
11	No Connection	Open/No connection
12	No Connection	
13	No Connection	
14	No Connection	
15	No Connection	
16	No Connection	
17	No Connection	
18	No Connection	
19	No Connection	
20	No Connection	

Pin	Name	Function
21	Port_C0	Multi-turn I/O protocol depends on Port_SEL[3:0] or internal register selection
22	Port_C1	
23	Port_C2	
24	Port_C3	
25	AGND	Analog ground
26	VDDA	Analog power 3.3V/5V
27	Port_D0	Incremental and analog output depend on Port_SEL[3:0] or internal register selection
28	Port_D1	
29	Port_D2	
30	Port_D3	
31	nRESET	Power-up delay or ASIC reset pin
32	Port_SEL0	Protocol selection or output selection pin. Refer to the AR55 series application note for selection details.
33	Port_SEL1	
34	Port_SEL2	
35	Port_SEL3	
36	Port_E0	I ² C SDA External EEPROM
37	Port_E1	I ² C SCL External EEPROM
38	VDDcap_1p8V	Buffer capacitor, 1.8V
39	VDDcap_3p3V	Buffer capacitor, 3.3V
40	External Oscillator	50-Mhz external oscillator input

NOTE: For additional PORT_SEL[3:0] selection information, refer to the AR55 series application note.

Package Marking

Figure 8: Product Marking Information

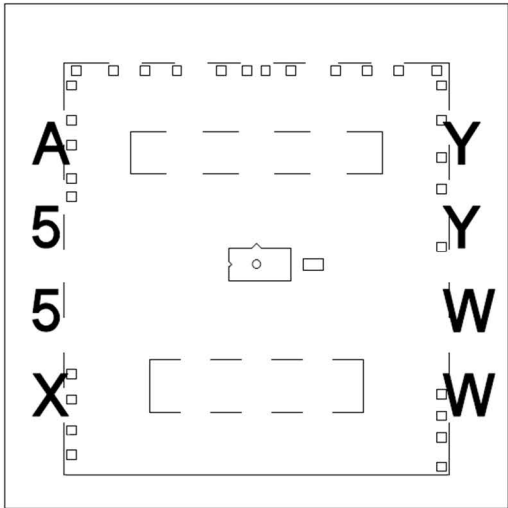

MARKING CONFIGURATION

PART NUMBER	PROTOCOL	MARKING
AR55S	STANDARD	A55S
AR55B	BISS	A55B

YYWW: YEAR, WORK WEEK

Encoder Mounting

Figure 9: Encoder Mounting Orientation for Rotary Applications

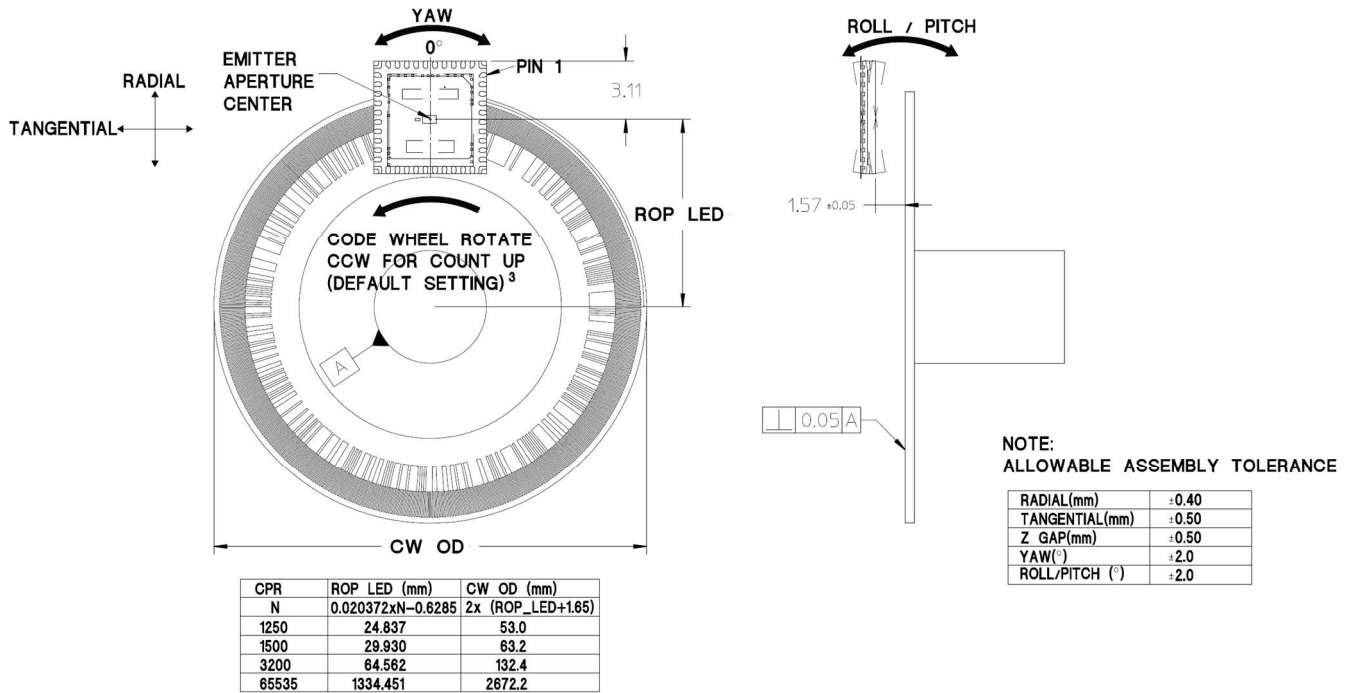
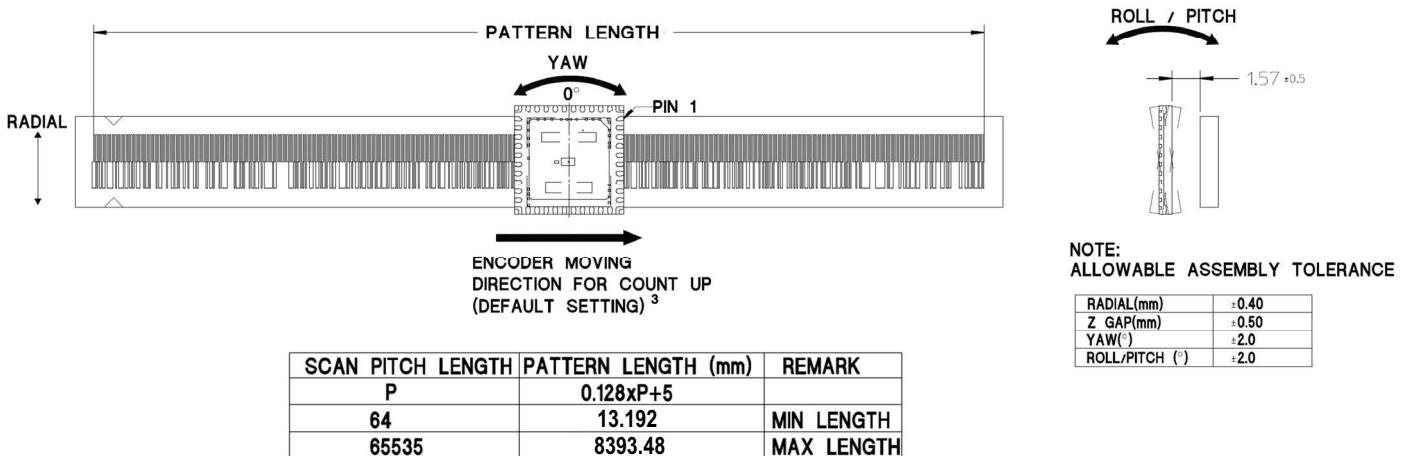

Figure 10: Encoder Mounting Orientation for Linear Applications



NOTE:

- The assembly of the encoder requires a clean room condition, Class 100k or better.
- The encoder requires an IP50 or higher rated enclosure for optimal protection against external contamination.
- For more mechanical design requirements, refer to the AR55 series application note.
- Contact your Broadcom sales representative for nonstandard code wheel or code strip designs.

Recommended PCB Land Pattern

Figure 11: Recommended PCB Land Pattern Details

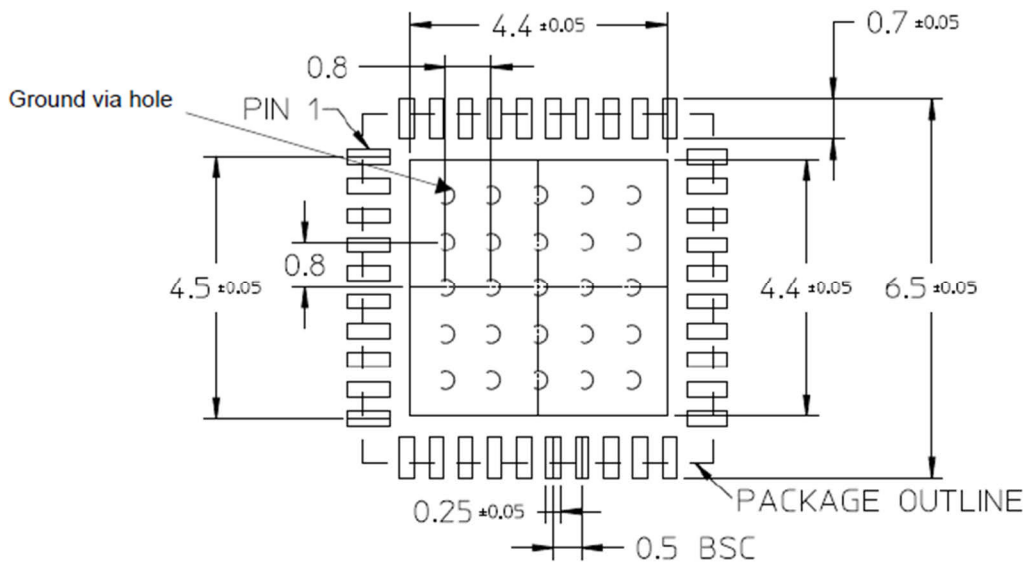

NOTE:

- Apply solder mask to areas that are not soldered.
- Use a 4-layer PCB with 25 × ø0.3mm, pitch = 0.8 mm via hole at the center pad as shown in the land pattern above.
- The center pad must be connected to GND.

For additional mechanical design requirements, refer to the AR55 series application note.

Moisture Sensitivity Level

The AR55 package is specified to moisture sensitive level 3 (MSL 3). Take precautions when handling this moisture-sensitive product to ensure the reliability of the product.

Storage before use:

- An unopened moisture barrier bag (MBB) can be stored at $<40^{\circ}\text{C}/90\%$ RH for 12 months.
- Open the MBB just prior to assembly.

Control after opening the moisture barrier bag (MBB):

The encoder that will be subjected to reflow solder must be mounted within 168 hours of factory conditions of $30^{\circ}\text{C}/60\%$ RH.

Control for unfinished reel:

Store a sealed MBB with desiccant or desiccators at $<5\%$ RH condition.

Baking is required if the any of following conditions exist:

- The humidity indicator card (HIC) is $>10\%$ when read at $23^{\circ}\text{C} \pm 5^{\circ}\text{C}$.
- The encoder floor life exceeded 168 hours.

The recommended baking condition is $40^{\circ}\text{C} \pm 5^{\circ}\text{C}$ for 22 hours (tape and reel) or $125^{\circ}\text{C} \pm 10^{\circ}\text{C}$ for 1 hour (loose units).

Figure 12: Recommended SMT Reflow Soldering Profile

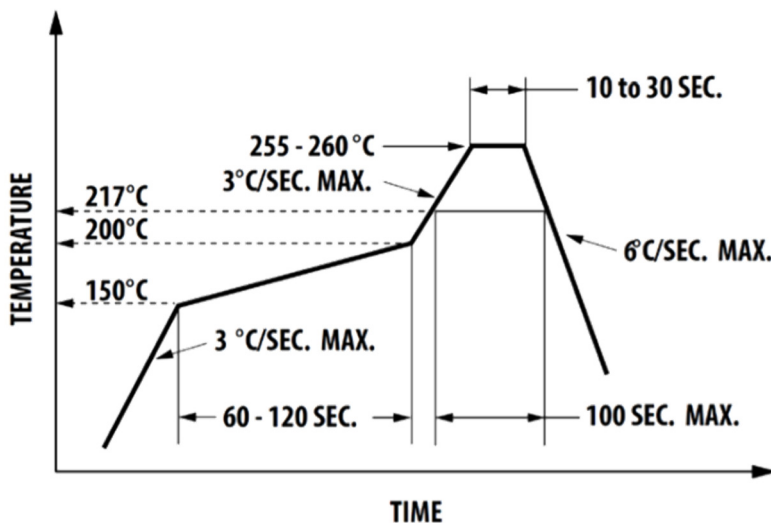

NOTE:

- Pb-free SMT reflow soldering profile (according to JEDEC Pb-Free [J-STD-020D]).
- Infrared reflow and no cleaning process to prevent contamination.

Product Specifications

Absolute Maximum Rating

Table 2: Absolute Maximum Ratings

Parameter	Symbol	Value
Storage Temperature	T_S	-40°C to 125°C
Operating Temperature	T_A	-40°C to 125°C
Supply Voltage	V_{dd}	-0.3V to +6.5V
ESD (HBM), JS-001-2014	—	±2 kV
Moisture Sensitive Level	MSL	3 (Maximum floor life = 168 hours)

NOTE:

- Proper encoder operation cannot be guaranteed if the maximum ratings are exceeded.
- Take precautions to keep the encoder ASIC clean at all times: clean room condition, Class 100k or better.
- Some particles may be present on the surface of the encoder ASIC surface. The presence of these particles may degrade the performance of the encoder.

CAUTION! Anti-static discharge precautions should be taken when handling the encoder in order to avoid damage and/or degradation induced by ESD.

Subjecting the product to stresses beyond those listed in this section may cause permanent damage to the devices. These are stress ratings only and do not imply that the device will function beyond these ratings. Exposure to the extremes of these conditions for extended periods may affect product reliability.

Electrical Specifications

Table 3: Recommended Operating Conditions

Parameter	Symbol	Min.	Typ.	Max.	Unit	Notes
DC Supply Voltage, 5V	V_{dd}	+4.5	+5.0	+5.5	V	
DC Supply Voltage, 3.3V	V_{dd}	+3.0	+3.3	+3.6	V	
Ripple of Supply Voltage	—	—	—	100	mVpp	100 kHz
Output Current per Channel	—	—	—	±5	mA	Single-ended digital output
Rise Time	t_r	—	30	—	ns	$C_L = 50$ pF $R_L = 1.2$ k Ω
Fall Time	t_f	—	30	—	ns	
Ambient Temperature	T_{amb}	—	+25	—	°C	
Operational Temperature	T_{PCB}	-40	+25	+125	°C	PCB (FR4, 4 layers) temperature
Storage Temperature	T_S	-40	+25	+125	°C	
Humidity	RH	—	—	85	%	Temperature = 40°C
INC Operating Frequency	—	—	—	156	kHz	Velocity (rpm) × CPR/60
Linear Speed	—	—	—	20	m/s	
Radial Misalignment	—	-500	Nominal	+500	μ m	
Tangential Misalignment	—	-400	Nominal	+400	μ m	
Gap	—	-500	Nominal	+500	μ m	
Temperature Sensor Accuracy	—	—	±3	—	°C	At 125°C

Table 4: Recommended Code Wheel or Code Strip Characteristics

Parameter	Symbol	Min.	Typ.	Max.	Unit	Notes
Specular Reflectance	R_f	80%	—	—	—	Reflective area
		—	—	5%	V	Non-reflective area

NOTE: Characteristics are based on Broadcom-qualified code wheel and code strip suppliers. Contact Broadcom for qualified reflective code wheel and code strip suppliers.

Figure 13: Metal (Stainless Steel or Aluminum) Code Wheel and Code Strip Structure

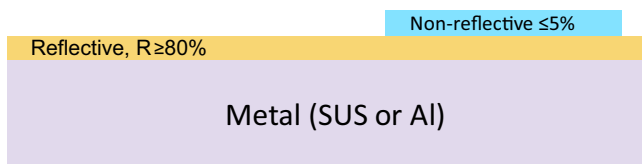
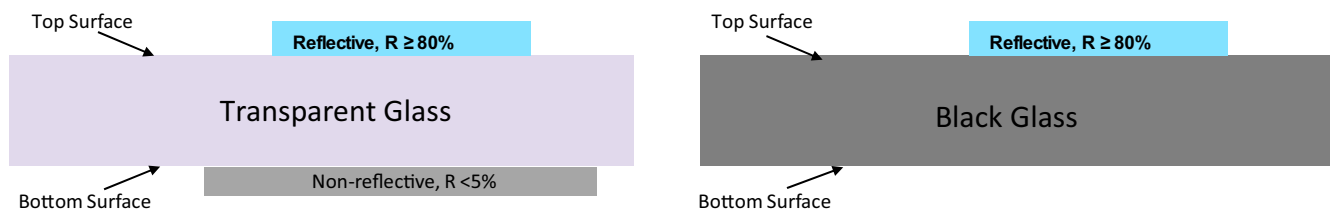

Figure 14: Glass Code Wheel and Code Strip Structure



DC Characteristics

Table 5: DC Characteristics over Recommended Operating Range, at 25°C (typical)

Parameter	Symbol	Conditions	Min.	Typ.	Max.	Unit	Notes
V _{DD} Supply Current	I _{DD}	V _{DD} = 3.3V	—	75	—	mA	
		V _{DD} = 5.0V	—	85	—	mA	
Absolute Single Turn Resolution	ST _{bits}	—	1	—	32 ^a	Bit	
Incremental Resolution	—	—	1	—	2 ^{nmax}	CPR	n _{max} = 26
Protocol I/O Drive Strength	I _{DIO}	V _{DD} = 3.3V/5V	5	20	40	mA	Differential driver
Differential Transceiver Hysteresis	V _{hys}	V _{DD} = 3.3V/5V	—	100	—	mV	220Ω termination
Differential Transceiver Opening	V _{open}	V _{DD} = 3.3V/5V	200	—	—	mV	
Differential Transceiver Voltage Peak-to-Peak	V _{PP}	V _{DD} = 3.3V/5V	—	2	—	V	
Output High Voltage	V _{OH}	V _{DD} = 3.3V	2.4	—	—	V	No load
Output Low Voltage	V _{OL}		—	5	0.4	V	
Input High Voltage	V _{IH}		—	—	2	V	
Input Low Voltage	V _{IL}		0.8	—	—	V	
Output High Voltage	V _{OH}	V _{DD} = 5.0V	4.4	—	—	V	No load
Output Low Voltage	V _{OL}		—	5	0.5	V	
Input High Voltage	V _{IH}		—	—	3.5	V	
Input Low Voltage	V _{IL}		1.5	—	—	V	

a. The maximum number of bits is set in the AR55 device.

Encoder Characteristics

Table 6: Incremental Characteristics over Recommended Operating Condition, at 25°C with Interpolation Factor of 32x

ABI Parameter	Symbol	Min.	Typ.	Max. ^a	Units
Cycle Error	ΔC	—	—	45	°e
State Error	ΔS	—	—	45	°e
Index Pulse Width	Po	—	90, 180, 270, 360	—	°e

a. Maximum values represent the encoder performance across the range of recommended mounting tolerance.

Table 7: Commutation Characteristic over Recommended Operating Condition, at 25°C with 32 Pole Pairs

Commutation (UVW) Parameter	Symbol	Min.	Typ.	Max. ^a	Units
Commutation Accuracy (Middle of Channel I to Channel U)	ΔI	-0.1	—	+0.1	°mechanical
Commutation Accuracy (Channel U, V, and W)	ΔUVW	-0.1	—	+0.1	°mechanical

a. Maximum values represent the encoder performance across the range of recommended mounting tolerance.

Table 8: Rotary Encoder Raw Accuracy Characteristics over Recommended Operating Condition, at 25°C

Parameter	Symbol	Min.	Typ. ^a	Max.	Units
Raw Accuracy (AR55)	—	—	±600	—	arcsec
Accuracy_AutoCal (Speed) ^b	—	—	±120	—	arcsec
Accuracy_ManualCal (Reference Encoder) ^c	—	—	±30	—	arcsec

a. Typical values represent the encoder performance with shaft TIR <20 µm, pattern eccentricity <60 µm for 1500 CPR.

b. Typical values represent calibration with the motor speed ripple of <0.1%.

c. Typical values represent the accuracy and repeatability when calibrated with a reference encoder having 10× higher accuracy than the AR55. (AR55 = 32-bit; reference encoder ≤3 arcsec).

Table 9: Linear Raw Accuracy Characteristics over Recommended Operating Condition, at 25°C with 1m Code Strip Length

Parameter	Symbol	Min.	Typ.	Max.	Units
Raw Accuracy (AR55)	—	—	±50	—	µm
Accuracy_AutoCal (Speed) ^a	—	—	±10	—	µm
Accuracy_ManualCal (Reference Encoder) ^b	—	—	±5	—	µm

a. Typical values represent calibration with the motor speed ripple of <0.1%.

b. Typical value represent the accuracy and repeatability when calibrated with a reference encoder having 10× higher accuracy than the AR55. (reference encoder ≤0.5 µm).

Analog Signal Characteristics

Figure 15: Analog Waveform

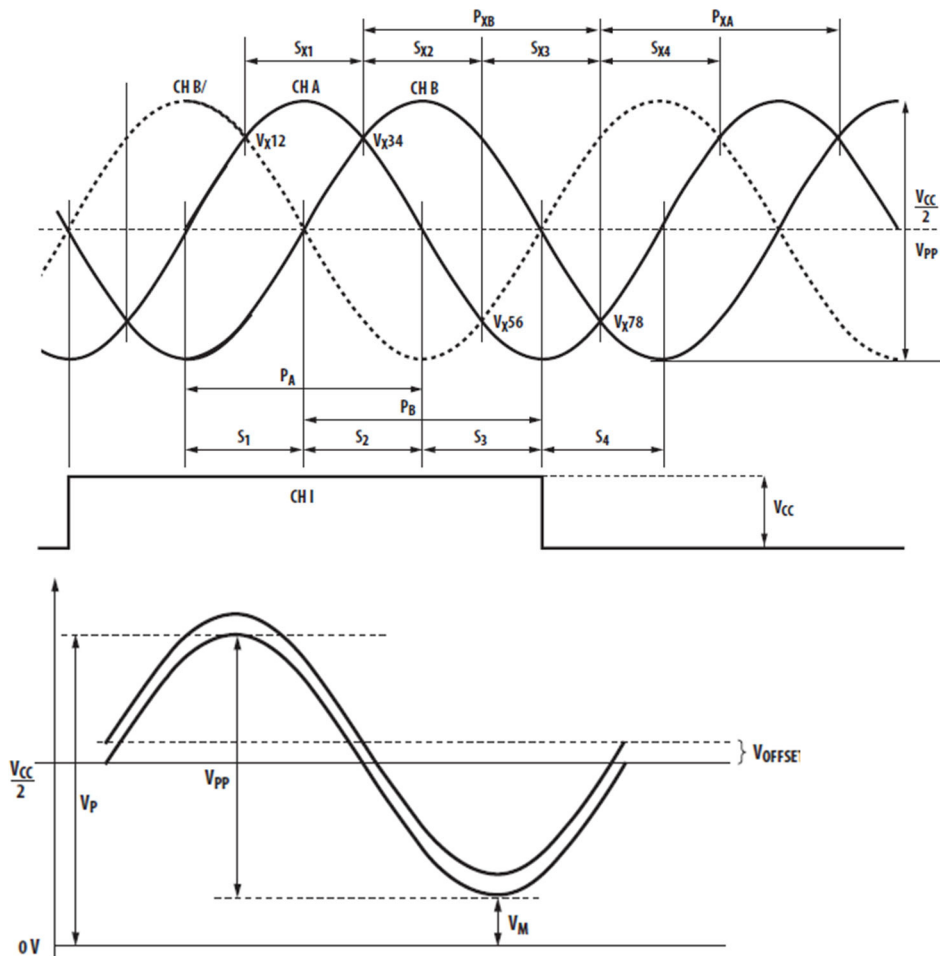

Table 10: Test Parameter Definitions

Parameter	Symbol	Description
Analog Peak-to-Peak	Vpp	The peak-to-peak signal magnitude in V of the analog signal.
Analog Offset	V _{OFFSET}	The offset in mV from the mid-point of the analog peak-to-peak signal to the zero voltage point.
Analog Peak/Valley Voltage	V _{PA} , V _{PB} , V _{MA} , V _{MB}	The value in V of the peak/valley of the analog signal (one-sided reading).
Analog Peak to Peak Voltage	V _{PPA} , V _{PPB}	The absolute difference between V _P and V _M of channel A or B.
Analog Crosspoint Voltage	V _{X12} , V _{X34} , V _{X56} , V _{X78}	The intersections in V of channel A analog waveform with that of either channel B or its component.
Analog Offset Voltage	V _{OFFSETA} , V _{OFFSETB}	The offset in mV from the midpoint of the analog peak-to-peak signal to Vpp/2.

Table 11: Analog Signal Characteristics

Parameter	Symbol	Min.	Typ.	Max.	Unit
Peak-to-Peak Voltage (Average)	V_{PPA}, V_{PPB}	0.9	1	1.1	V
Analog Offset Voltage	$V_{OFFSETA}, V_{OFFSETB}$	$0.45V_{CC}$	$0.5V_{CC}$	$0.55V_{CC}$	V
Voltage Reference (Midpoint of Signal Vpp)	V_{ref}	—	$V_{CC}/2$	—	V
Index Pulse Width	I	—	360/270/180/90	—	°e
State Width Error	ΔS	—	± 10	—	°e
Pulse Width Error	ΔP	—	± 10	—	°e
State X Width Error	ΔS_x	—	± 5	—	°e
Pulse X Width Error	ΔP_x	—	± 5	—	°e

NOTE:

- Typical values represent the average value of encoder performance in our factory-based setup conditions.
- The optimal performance of the encoder depends on the individual customer's motor/system set-up conditions.

Evaluation Board and Accessories

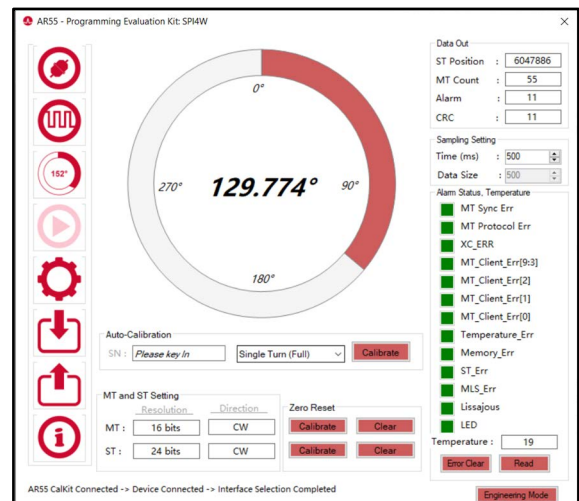
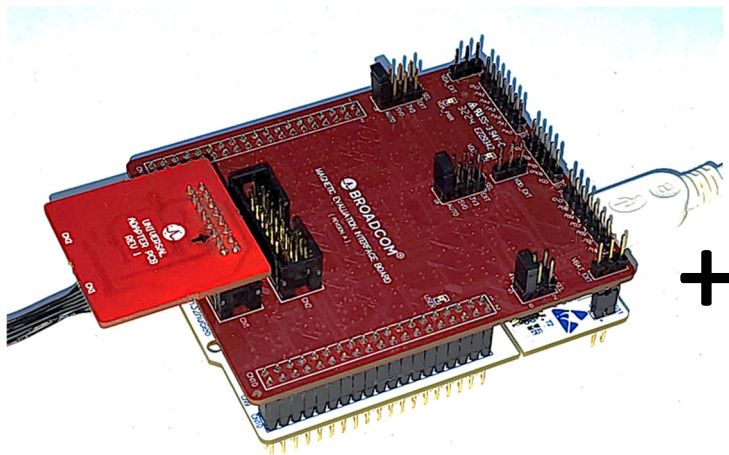
Figure 16: AR49-M49-E01 Calibration Kit and User Interface Software

The Programming/Calibration Kit with a USB PC Interface Cable and an Encoder Connecting Cable

The Programming/Calibration GUI Software

Figure 17: AR55 Encoder Evaluation Board

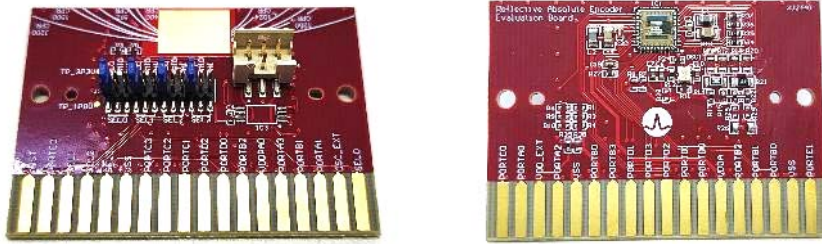

Figure 18: AR55 Metal Code Wheel or Code Strip



Figure 19: AR55-EVBR with Evaluation Board and a 1250-CPR Metal Code Wheel

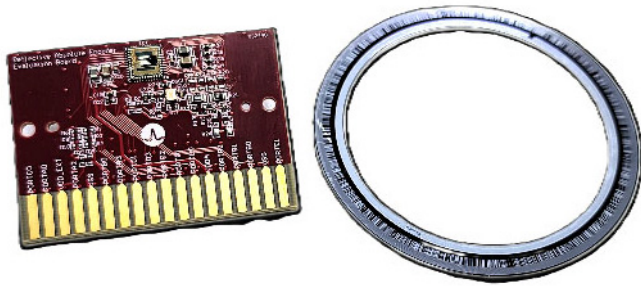
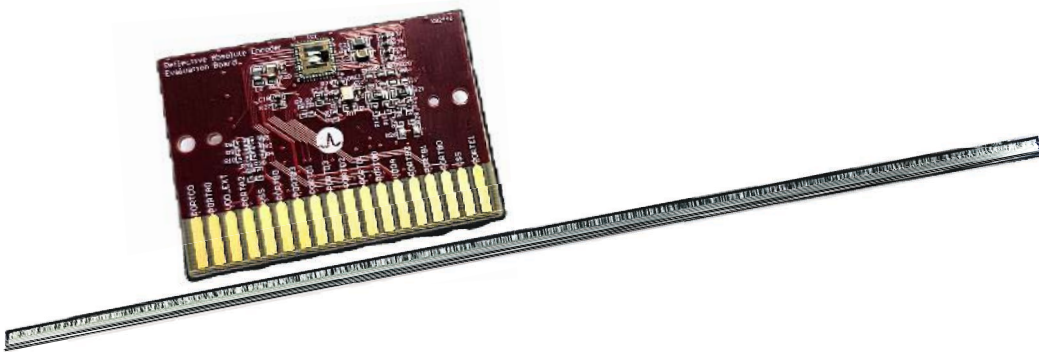

Figure 20: AR55-EVBL with Evaluation Board and a 200-mm Linear Code Strip



Ordering Information

A R 5 5 - A Y 0 1 - T R 0 X

Code	Description	Option	
Y	Communication Protocol	B	BiSS-C (10 MHz)
		S	SSI (10 MHz) SPI 4-wire (10 MHz) ESL (10 Mb/s) RS-485 (2.5/5/10 Mb/s)
X	Tape and Reel Quantity	1	100 pieces
		2	1000 pieces

Part Number	Description
AR55-EVBR	AR55 Evaluation Board (All Protocols) and Metal Code Wheel, 1250 CPR
AR55-EVBL	AR55 Evaluation Board (All Protocols) and Metal Code Strip, 200 mm
AR55-R30S	Code Wheel 1250 CPR, ID 41 mm, Metal
AR55-R60S	Code Wheel only 1850 CPR, ID 65.4 mm, Metal
AR55-L20S	Code Strip only 1640 CPR, 200 mm, Metal
W1202-495249	Bearing Stage AR55 + R30S + QP39-T254
AR55-AS01-TR01	AR55 ASIC Protocol SSI/SPI/485/ESL, Tape and Reel 100 pieces
AR55-AS01-TR02	AR55 ASIC Protocol SSI/SPI/485/ESL, Tape and Reel 1000 pieces
AR55-AB01-TR01	AR55 ASIC Protocol BiSS-C, Tape and Reel 100 pieces
AR55-AB01-TR02	AR55 ASIC Protocol BiSS-C, Tape and Reel 1000 pieces
AR49-M49-E01	Universal Programming Kit (applicable for all protocol options) Contents: 1 unit of MCU-based programming kit, 1 unit of USB cable for PC interface, DUT cable and the associated programming software.
AR25-AC25	Accuracy Calibration Station for AR18/AR25/AR35/AR49/AR55 Series Rotary Reflective Encoder Contents: Mechanical setup including servo motor control, high accuracy reference encoder, programming kits, associated cables assemblies (for PC interface, motor handler communication, DUT encoder connection), and the associated GUI programming software.

Copyright © 2025 Broadcom. All Rights Reserved. The term “Broadcom” refers to Broadcom Inc. and/or its subsidiaries. For more information, go to www.broadcom.com. All trademarks, trade names, service marks, and logos referenced herein belong to their respective companies.

Broadcom reserves the right to make changes without further notice to any products or data herein to improve reliability, function, or design. Information furnished by Broadcom is believed to be accurate and reliable. However, Broadcom does not assume any liability arising out of the application or use of this information, nor the application or use of any product or circuit described herein, neither does it convey any license under its patent rights nor the rights of others.