

MATERIALS AND FINISHES:

SMA JACK STR BH IP68 CONNECTOR  
MOLEX PN. 73251-4510

BODY & JAM NUT: BRASS  
PLATED: NICKEL

CRIMP TUBE: BRASS  
PLATED: NICKEL

CENTER CONTACT: BERYLLIUM COPPER  
PLATED: GOLD

INSULATOR: PTFE

PIN CONTACT: BRASS  
PLATED: GOLD

LOCK WASHER: PHOSPHOR BRONZE  
PLATED: NICKEL

GASKET: SILICONE RUBBER

MATERIALS AND FINISHES:

SMA PLUG STR CONNECTOR  
MOLEX PN. 73251-0451

BODY: BRASS  
PLATED: GOLD

COUPLING NUT: BRASS  
PLATED: GOLD

CONTACT: BRASS  
PLATED: GOLD

INSULATOR: PTFE

GASKET: SILICONE RUBBER

C-RING: BERYLLIUM COPPER

CRIMP TUBE: BRASS  
PLATED: NICKEL

MATERIALS AND FINISHES:

HEAT SHRINK TUBE: VERSAFIT

CABLE: RG316 OR EQUIVALENT

PERFORMANCE REQUIREMENTS:

FREQUENCY RANGE: 0-6GHz

IMPEDANCE: 50 OHMS

WITHSTAND VOLTAGE(AC): 500V @0.5mA

CONTINUITY: 100% TEST

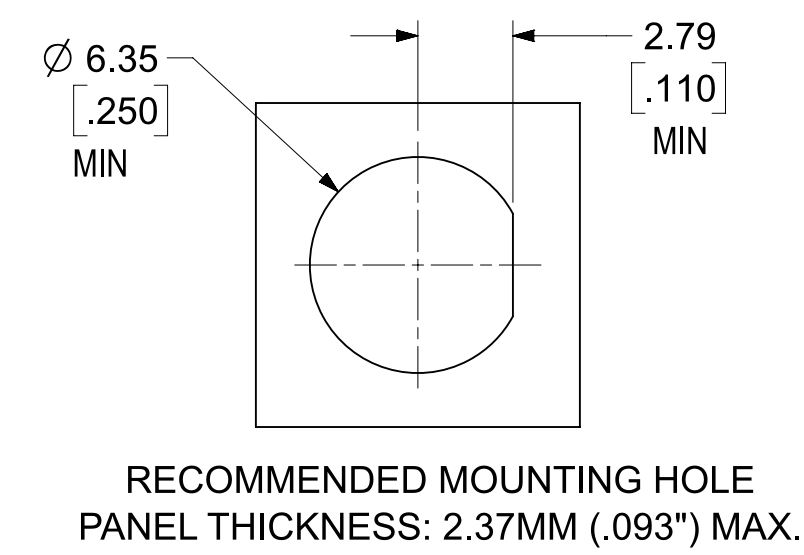
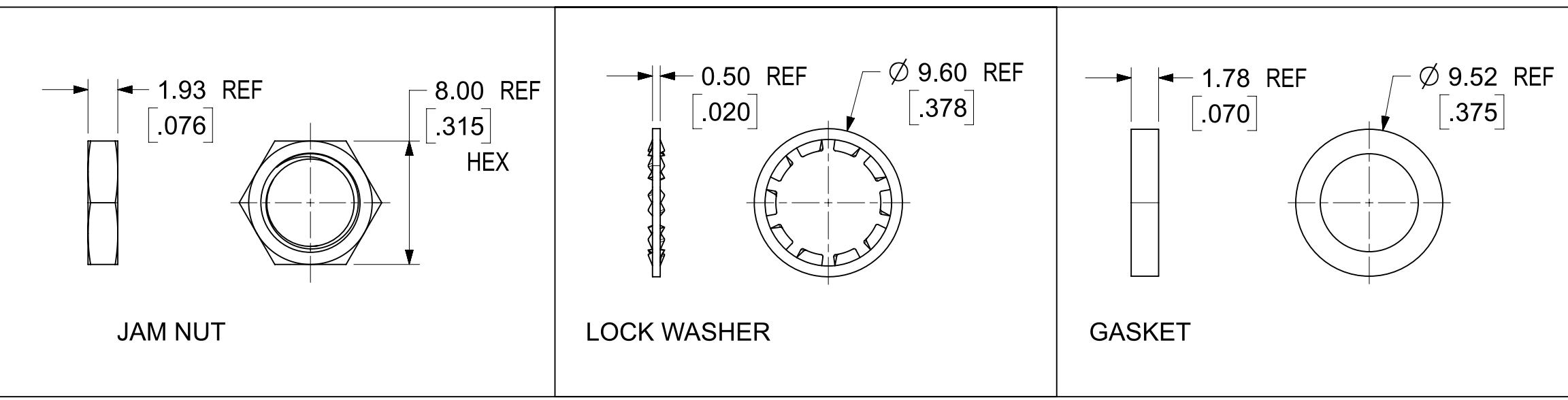
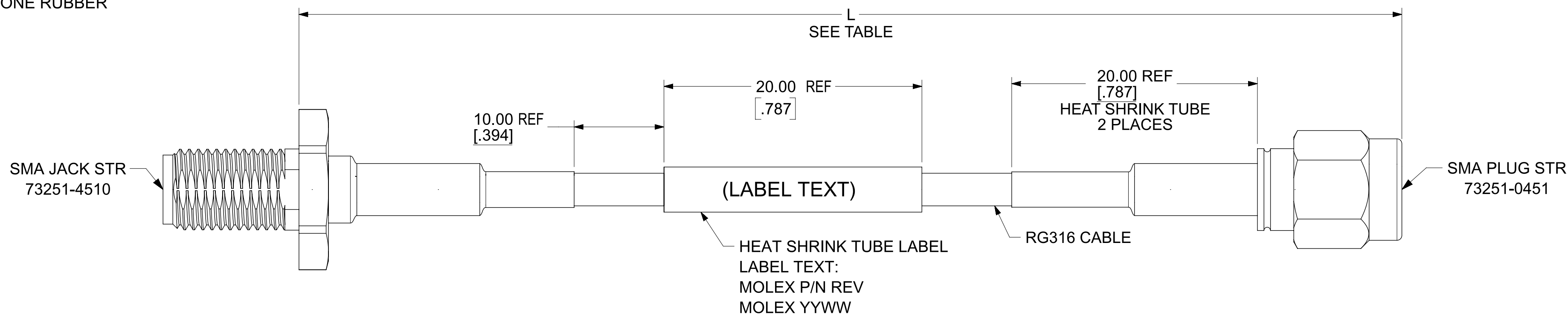
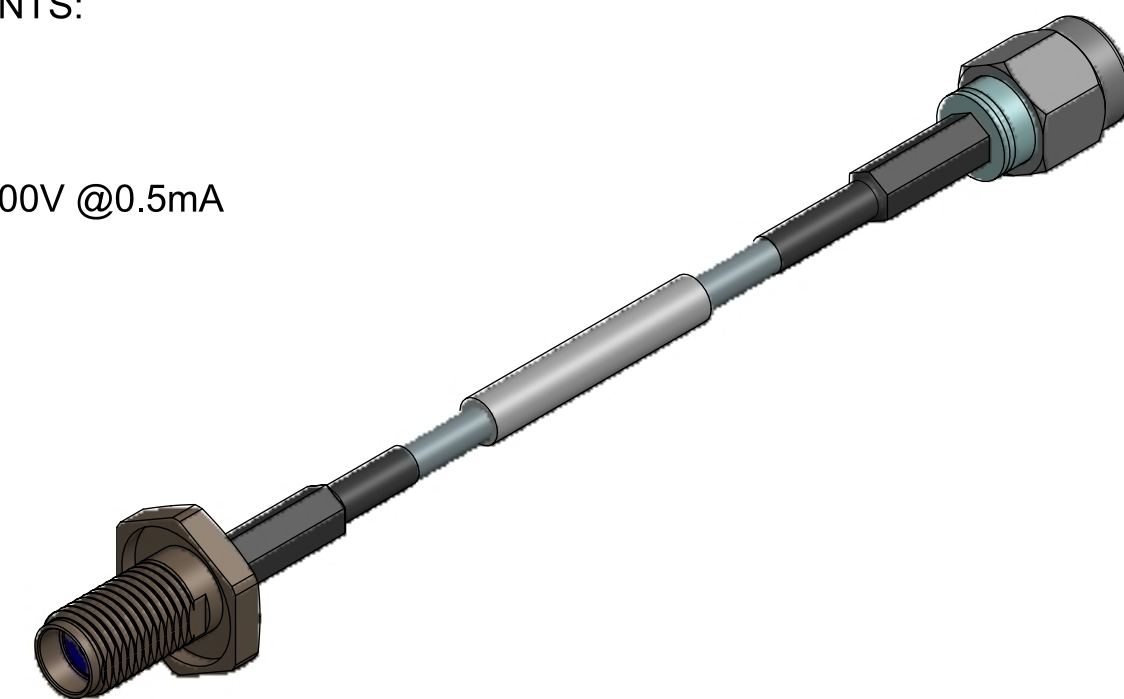

TABLE:

PART NO.	IN	MM	PACKAGING
73230-7086	39.370±.394	1000.00±10.00	PLASTIC BAG / POLY BAG
73230-7085	36.000±.394	914.40±10.00	
73230-7084	24.000±.394	609.60±10.00	
73230-7083	19.685±.394	500.00±10.00	
73230-7082	12.000±.394	304.80±10.00	
73230-7081	9.843±.197	250.00±5.00	
73230-7080	6.000±.197	152.40±5.00	
	DIM L		

FUNCTIONAL SYMBOLS $\nabla_A = 0$ $\nabla_C = 0$ $\nabla_P = 0$ DIVISIONAL SYMBOLS	THIS DRAWING CONTAINS INFORMATION THAT IS PROPRIETARY TO MOLEX ELECTRONIC TECHNOLOGIES, LLC AND SHOULD NOT BE USED WITHOUT WRITTEN PERMISSION		CURRENT REV DESC: NEW RELEASE				
	DIMENSION UNITS	SCALE	 CA SMA JACK STR BH IP68 TO SMA PLUG STR ON RG316 PRODUCT SALES DRAWING				
	MM/INCH	NTS					
	GENERAL TOLERANCES (UNLESS SPECIFIED)						
ANGULAR TOL ± 2°							
4 PLACES ±		STATUS: Production DRWN: Dennison J 2023-10-25 CHK'D: Karthik N Sathyanarayana 2024-01-11 APPR: Bharath Bharadwaj D 2024-01-11					
3 PLACES ±							
2 PLACES ±							
1 PLACE ±							
0 PLACES ±		DOCUMENT NUMBER: 732307080 DOC TYPE: PSD DOC PART: 000 REVISION: A					
DRAFT WHERE APPLICABLE MUST REMAIN WITHIN DIMENSIONS		THIRD ANGLE PROJECTION	DRAWING	SERIES	MATERIAL NUMBER	CUSTOMER	SHEET NUMBER
			C-SIZE	73230	SEE TABLE	GENERAL MARKET	1 OF 1