

Current Sensor

Automotive Current Sense Amplifier

BD1423x-C Series

General Description

The BD1423x-C is a current sense amplifier series. This device operates from a single 2.7 V to 18 V power supply. It has wide common mode voltage range from -14 V to +80 V, outputs analog voltage. The gains are 3 types from 20 V/V to 100 V/V. The matched gain resistor minimizes gain error and offset voltage. In additionally, the low input bias current is 1 μ A that reduces the offset on the path to shunt resistor.

Features

- AEC-Q100 Qualified^(Note 1)
- Wide Common Mode Voltage Range
- High Accuracy
- Low Offset Voltage
- Low Input Bias Current
(Note 1) Grade 1

Applications

- On Board Charger
- DCDC Converter
- Electric Compressor

Key Specifications

- VDD Voltage Range: 2.7 V to 18 V
- Quiescent Current: 300 μ A (Typ)
- Common Mode Voltage Range: -14 V to +80 V
- Gain: 20 V/V to 100 V/V 3 types (Typ)
- Gain Accuracy: ± 1.0 % (Max)
- Operating Temperature Range: -40 $^{\circ}$ C to +125 $^{\circ}$ C

Product Name	Gain (Typ)
BD14230-C	20 V/V
BD14231-C	50 V/V
BD14232-C	100 V/V
BD14235-C	20 V/V
BD14236-C	50 V/V
BD14237-C	100 V/V

Package

TSSOP-B8J
SOP-J8

W (Typ) x D (Typ) x H (Max)

3.0 mm x 4.9 mm x 1.1 mm
4.9 mm x 6.0 mm x 1.65 mm



TSSOP-B8J

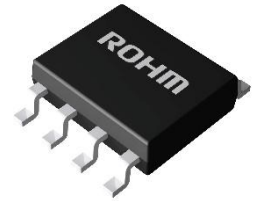

SOP-J8

Typical Application Circuit

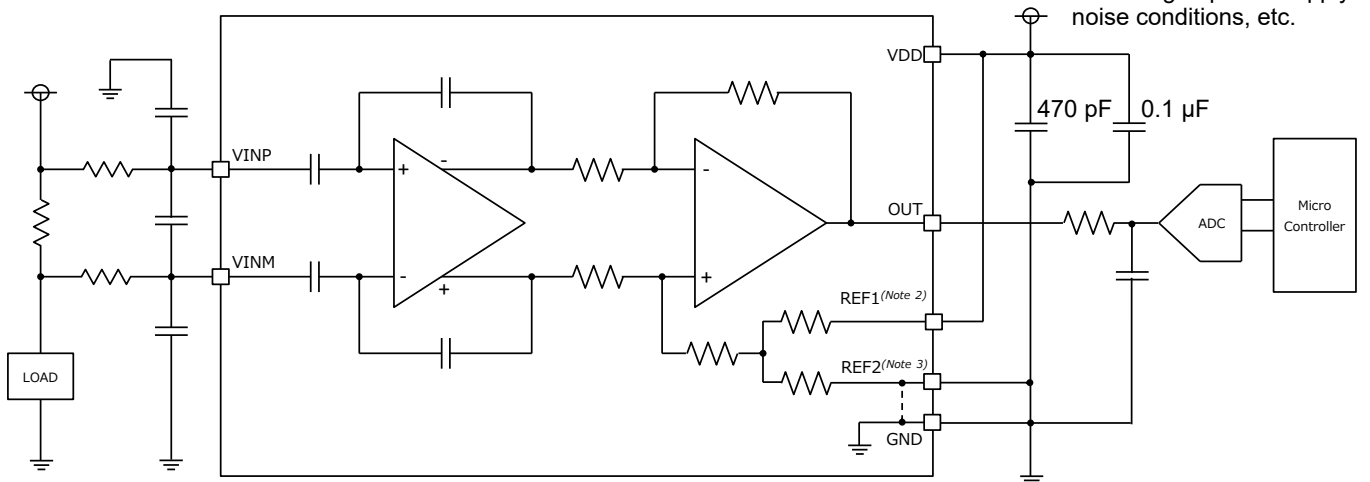

(Note 2) In BD14235-C, BD14236-C and BD14237-C, the pin name is OFFSET.

(Note 3) In BD14235-C, BD14236-C and BD14237-C, REF2 is connected to the internal GND and REF2 is not connected to pin.

Contents

General Description	1
Features.....	1
Applications	1
Key Specifications	1
Package.....	1
Typical Application Circuit	1
Pin Configuration	3
Pin Descriptions.....	3
Absolute Maximum Ratings	4
Thermal Resistance.....	4
Recommended Operating Conditions	5
Electrical Characteristics.....	5
Typical Performance Curves.....	6
Figure 1. Quiescent Current vs Operating Temperature	6
Figure 2. Offset Voltage vs Operating Temperature	6
Figure 3. Gain Accuracy vs Operating Temperature	6
Figure 4. Input Bias Current vs Operating Temperature	6
Figure 5. High-level Output Voltage vs Operating Temperature	7
Figure 6. Low-level Output Voltage vs Operating Temperature	7
Timing Chart	8
Application Examples	9
I/O Equivalence Circuits.....	11
Operational Notes.....	12
Ordering Information.....	14
Marking Diagram	14
Physical Dimension and Packing Information	15
Revision History.....	17

Pin Configuration

BD1423xFVJ-C (x = 0, 1, 2), BD1423xFJ-C (x = 0, 1, 2)

(TOP VIEW)

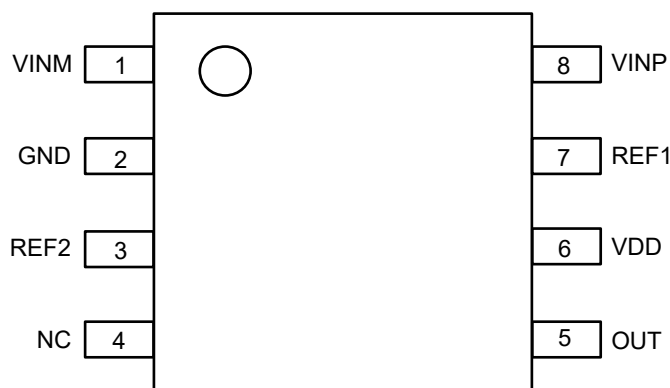

BD1423xFJ-C (x = 5, 6, 7)

(TOP VIEW)

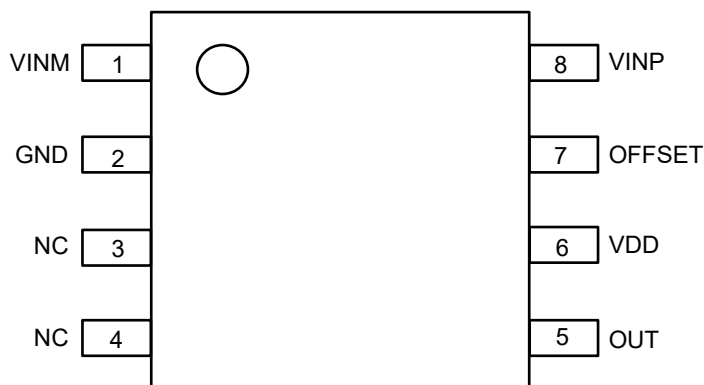

Pin Descriptions

BD1423xFVJ-C (x = 0, 1, 2), BD1423xFJ-C (x = 0, 1, 2)

Pin No.	Pin Name	Function
1	VINM	Voltage input of load side of shunt resistor
2	GND	Ground
3	REF2	Reference voltage 2
4	NC	No connection (Set to open)
5	OUT	Current detection output
6	VDD	Power supply ^(Note 4)
7	REF1	Reference voltage 1
8	VINP	Voltage input of supply side of shunt resistor

BD1423xFJ-C (x = 5, 6, 7)

Pin No.	Pin Name	Function
1	VINM	Voltage input of load side of shunt resistor
2	GND	Ground
3	NC	No connection (Set to open)
4	NC	No connection (Set to open)
5	OUT	Current detection output
6	VDD	Power supply ^(Note 4)
7	OFFSET	Reference voltage
8	VINP	Voltage input of supply side of shunt resistor

(Note 4) Dispose a bypass capacitor between VDD and GND

Absolute Maximum Ratings

Parameter	Symbol	Rating	Unit
Power Supply Voltage	V _{DD}	18.2	V
Common Mode Voltage	V _{CM}	-14 to +80	V
Differential Voltage (V _{VINP} - V _{VINM})	V _{SENSE}	±28	V
REF1, REF2, OFFSET Pin Voltage	V _{REF1} V _{REF2} V _{OFFSET}	-0.3 to (V _{DD} + 0.3) or +18.2 Whichever is less	V
Input Current Into Any Pin	I _{IN}	±5	mA
Storage Temperature Range	T _{stg}	-55 to +150	°C
Maximum Junction Temperature	T _{jmax}	150	°C

Caution 1: Operating the IC over the absolute maximum ratings may damage the IC. The damage can either be a short circuit between pins or an open circuit between pins and the internal circuitry. Therefore, it is important to consider circuit protection measures, such as adding a fuse, in case the IC is operated over the absolute maximum ratings.

Caution 2: Should by any chance the maximum junction temperature rating be exceeded the rise in temperature of the chip may result in deterioration of the properties of the chip. In case of exceeding this absolute maximum rating, design a PCB with thermal resistance taken into consideration by increasing board size and copper area so as not to exceed the maximum junction temperature rating.

Thermal Resistance (Note 5)

Parameter	Symbol	Thermal Resistance (Typ)		Unit
		1s (Note 7)	2s2p (Note 8)	
TSSOP-B8J				
Junction to Ambient	θ _{JA}	253.8	151.6	°C/W
Junction to Top Characterization Parameter (Note 6)	Ψ _{JT}	35	23	°C/W
SOP-J8				
Junction to Ambient	θ _{JA}	149.3	76.9	°C/W
Junction to Top Characterization Parameter (Note 6)	Ψ _{JT}	18	11	°C/W

(Note 5) Based on JESD51-2A (Still-Air).

(Note 6) The thermal characterization parameter to report the difference between junction temperature and the temperature at the top center of the outside surface of the component package.

(Note 7) Using a PCB board based on JESD51-3.

(Note 8) Using a PCB board based on JESD51-7.

Layer Number of Measurement Board	Material	Board Size
Single	FR-4	114.3 mm x 76.2 mm x 1.57 mmt

Top	
Copper Pattern	Thickness
Footprints and Traces	70 μm

Layer Number of Measurement Board	Material	Board Size
4 Layers	FR-4	114.3 mm x 76.2 mm x 1.6 mmt

Top		2 Internal Layers		Bottom	
Copper Pattern	Thickness	Copper Pattern	Thickness	Copper Pattern	Thickness
Footprints and Traces	70 μm	74.2 mm x 74.2 mm	35 μm	74.2 mm x 74.2 mm	70 μm

Recommended Operating Conditions

Parameter		Symbol	Min	Typ	Max	Unit	Condition
Power Supply Voltage	BD14230-C BD14235-C	V_{DD}	2.7	5.0	5.5	V	
	BD14231-C BD14232-C BD14236-C BD14237-C		2.7	5.0	18		
Common Mode Voltage		V_{CM}	-14	+12	+80	V	VINP, VINM
Operating Temperature		Topr	-40	+25	+125	°C	

Electrical Characteristics

(Unless otherwise specified $V_{DD} = 5\text{ V}$, $V_{CM} = 12\text{ V}$, $V_{REF1} = V_{REF2} = V_{OFFSET}/2 = 2.5\text{ V}$, $V_{SENSE} = (V_{VINP} - V_{VINM})$, $T_a = 25\text{ °C}$)

Parameter		Symbol	Min	Typ	Max	Unit	Condition
Power Supply							
Quiescent Current		I_{DD}	-	300	500	μA	$V_{SENSE} = 0\text{ mV}$
Current Sense Amplifier							
Offset Voltage	BD14230-C BD14231-C BD14232-C BD14236-C BD14237-C	V_{OS}	-	-	±0.5	mV	RTI ^(Note 9) , $V_{SENSE} = 0\text{ mV}$ $T_a = -40\text{ °C to }+125\text{ °C}$
	BD14235-C		-	-	±1.0	mV	RTI ^(Note 9) , $V_{SENSE} = 0\text{ mV}$ $T_a = -40\text{ °C to }+125\text{ °C}$
Gain	BD14230-C BD14235-C	G_{AIN}	-	20	-	V/V	
	BD14231-C BD14236-C		-	50	-		
	BD14232-C BD14237-C		-	100	-		
Gain Accuracy		G_{ERR}	-	-	±1.0	%	$V_{OUT} = 0.5\text{ V to }V_{DD} - 0.5\text{ V}$ $T_a = -40\text{ °C to }+125\text{ °C}$
Nonlinearity Error		Lin	-	±0.01	-	%	$V_{OUT} = 0.5\text{ V to }V_{DD} - 0.5\text{ V}$
Input Bias Current		I_{VINM}	-	-	±1.0	μA	$V_{SENSE} = 0\text{ mV}$ $T_a = -40\text{ °C to }+125\text{ °C}$
Band Width		BW	-	40	-	kHz	
High-level Output Voltage		V_{OUT_H}	$V_{DD} - 0.03$	-	-	V	OUT, $R_L = 10\text{ k}\Omega$ pulldown
Low-level Output Voltage		V_{OUT_L}	-	-	GND + 0.05	V	OUT, $R_L = 10\text{ k}\Omega$ pullup

(Note 9) RTI = Referred To Input

Typical Performance Curves

(Unless otherwise specified $V_{DD} = 5\text{ V}$, $V_{CM} = 12\text{ V}$, $V_{REF1} = V_{REF2} = V_{OFFSET}/2 = 2.5\text{ V}$, $V_{SENSE} = (V_{VINP} - V_{VINM})$, $T_a = 25\text{ }^\circ\text{C}$)

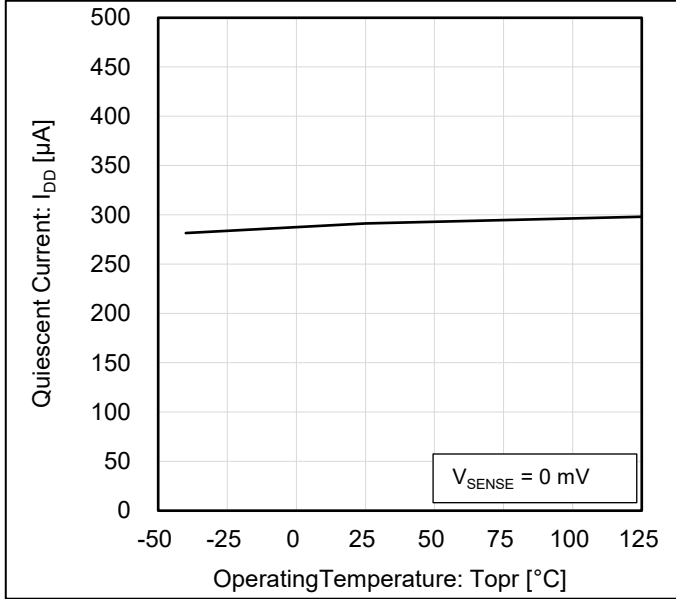

Figure 1. Quiescent Current vs Operating Temperature

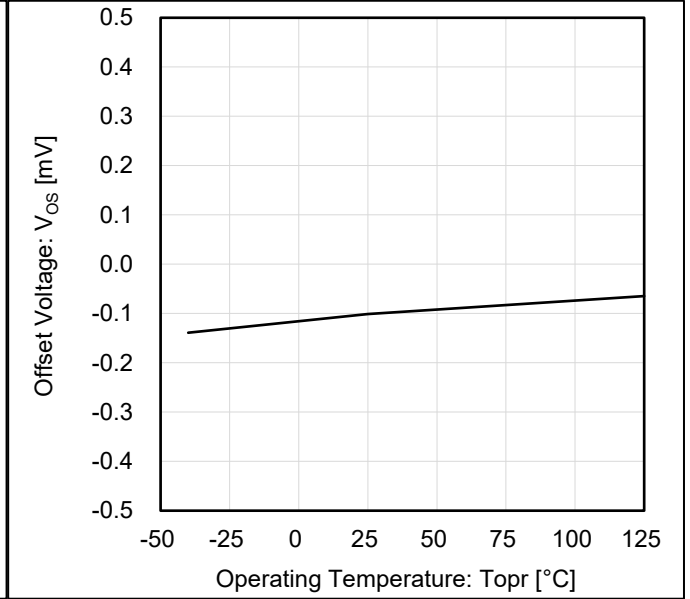

Figure 2. Offset Voltage vs Operating Temperature

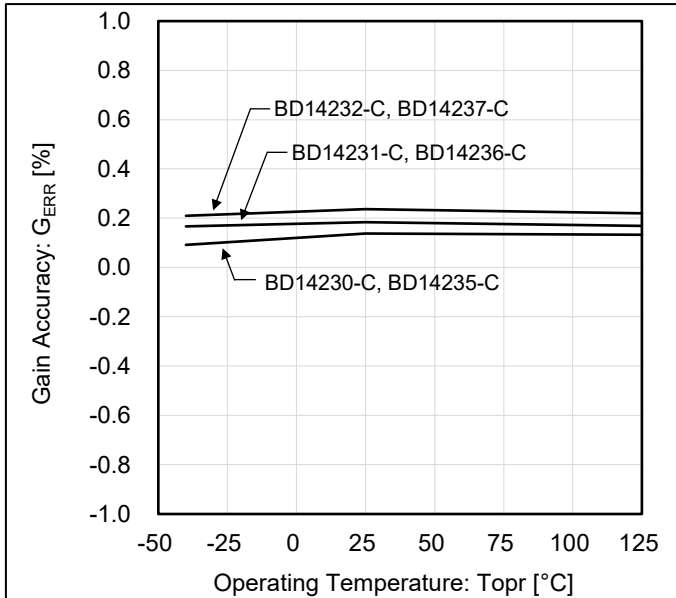

Figure 3. Gain Accuracy vs Operating Temperature

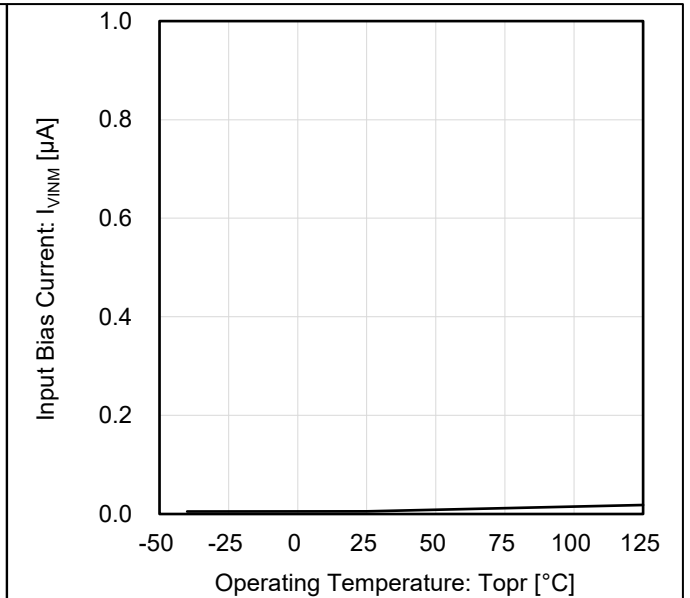

Figure 4. Input Bias Current vs Operating Temperature

Typical Performance Curves - continued

(Unless otherwise specified $V_{DD} = 5\text{ V}$, $V_{CM} = 12\text{ V}$, $V_{REF1} = V_{REF2} = V_{OFFSET}/2 = 2.5\text{ V}$, $V_{SENSE} = (V_{VINP} - V_{VINM})$, $T_a = 25\text{ }^\circ\text{C}$)

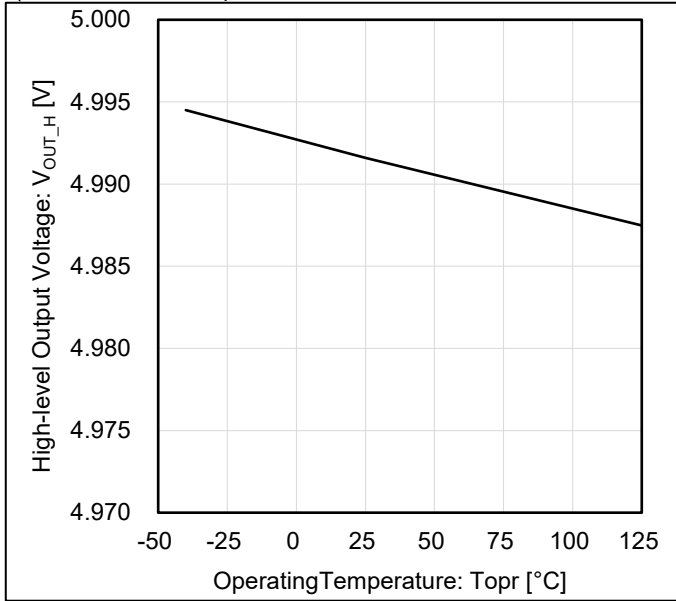

Figure 5. High-level Output Voltage vs Operating Temperature

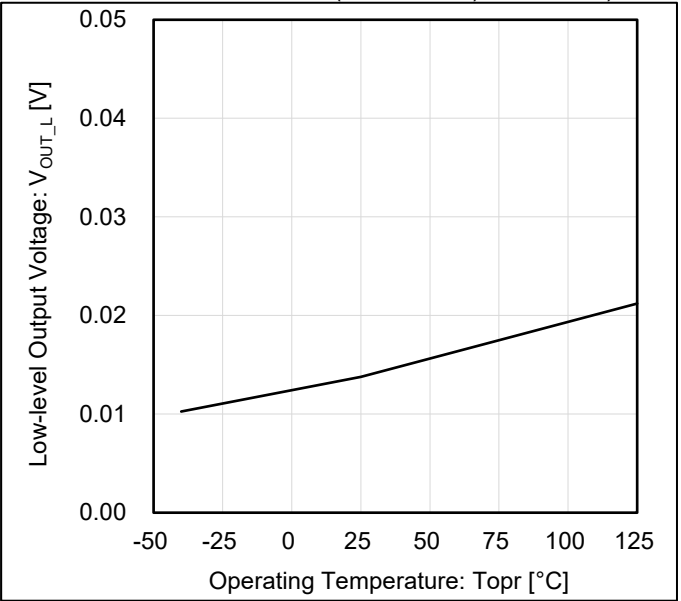

Figure 6. Low-level Output Voltage vs Operating Temperature

Timing Chart

1. Control Sequence

1.1 Power supply start-up sequence

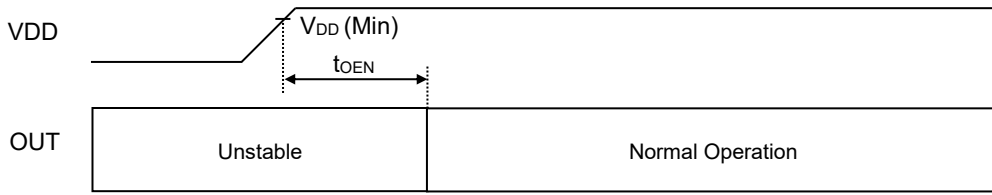

Figure 7. Timing Chart at Power ON

Stable time of OUT (t_{OEN}) should be 1 ms or more.

1.2 Power supply off sequence

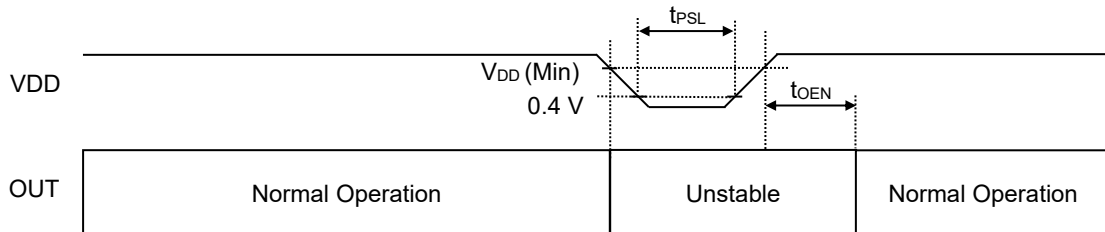

Figure 8. Timing Chart at Power OFF

Power off time (t_{PSL}) should be 1 ms or more.

If V_{DD} is under the recommended operating condition, LSI is unstable state. In that case, set Power OFF and ON again. When the power is ON again, the period of V_{DD} < 0.4 V should be t_{PSL} or more.

Application Examples

This IC has the structure specialized for Current Sense Amplifier and has the following features. Common mode voltage range is maximum 80 V with V_{DD} of maximum 18 V (maximum 5.5 V for BD14230-C, BD14235-C), therefore it is possible to detect the current flowing in a power supply line exceeding V_{DD} voltage. And its input bias current is very low.

This IC amplifies the voltage difference across the shunt resistor between V_{INP} and V_{INM} and outputs an intermediate voltage with REF1 pin and REF2 pin as reference voltage. When connecting REF1 pin to V_{DD} pin and REF2 pin to GND pin, output with reference to $V_{DD}/2$, which is half of a supply voltage. If the current flows from V_{INP} to V_{INM} , OUT pin voltage is higher than $V_{DD}/2$. If the current flows from V_{INM} to V_{INP} , OUT pin voltage is lower than $V_{DD}/2$. When the voltages of V_{INP} and V_{INM} are equal, OUT pin voltage is equal to $V_{DD}/2$.

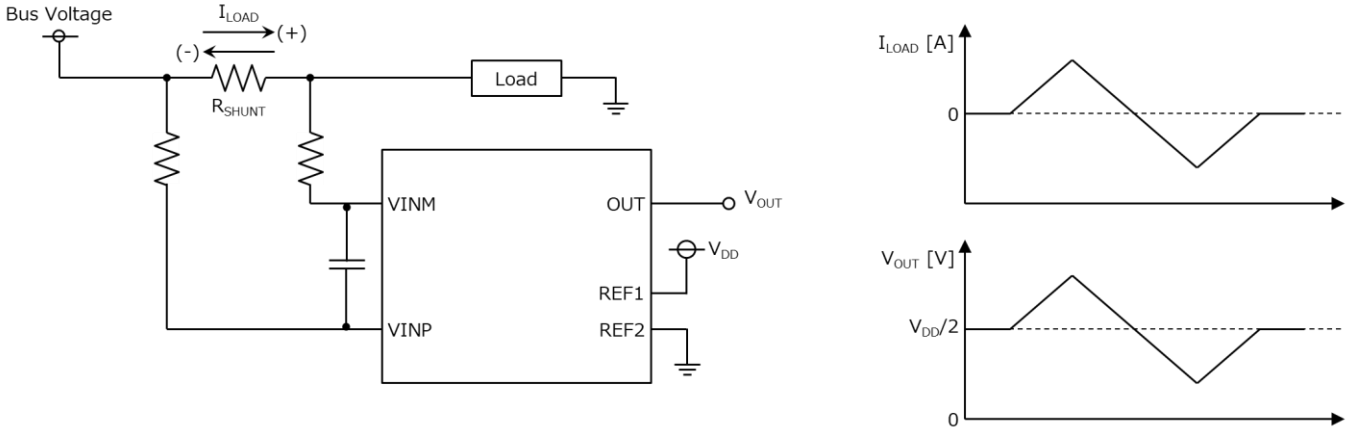

Figure 9. Basic Explanation 1

When REF1 pin and REF2 pin voltages are the same potential as the external reference voltage V_{REF} , output with V_{REF} as the reference. If the current flows from V_{INP} to V_{INM} , OUT pin voltage is higher than V_{REF} . If the current flows from V_{INM} to V_{INP} , OUT pin voltage is lower than V_{REF} . When the voltages of V_{INP} and V_{INM} are equal, OUT pin voltage is equal to V_{REF} .

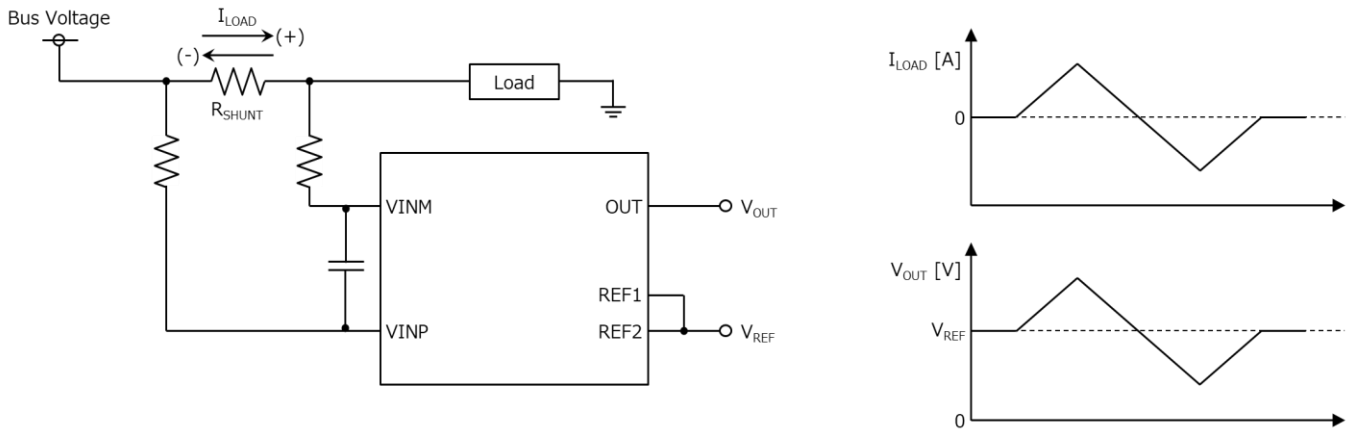

Figure 10. Basic Explanation 2

Application Examples - continued

In BD1423xFJ-C (x = 5, 6, 7), the REF2 pin is internally connected to GND. The external reference voltage is input to the OFFSET pin and the output voltage is output with reference to $V_{OFFSET}/2$.

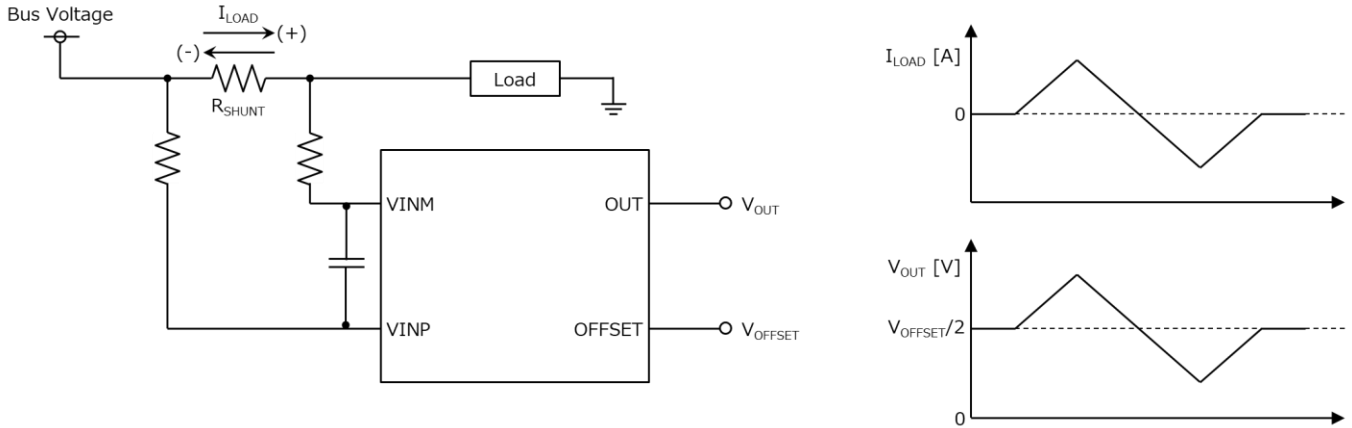

Figure 11. Basic Explanation 3

In BD1423xFVJ-C (x = 0, 1, 2) and BD1423xFJ-C (x = 0, 1, 2), V_{OUT} is calculated by the below formula.

$$V_{OUT} = (R_{SHUNT} \times I_{LOAD} \times G_{AIN}) + V_{REF}$$

In BD1423xFJ-C (x = 5, 6, 7), V_{OUT} is calculated by the below formula.

$$V_{OUT} = (R_{SHUNT} \times I_{LOAD} \times G_{AIN}) + \frac{V_{OFFSET}}{2}$$

Where,

- R_{SHUNT} is the Shunt resistance
- I_{LOAD} is the Load current
- G_{AIN} is the Gain of Current Sense Amplifier
- V_{REF} is the intermediate voltage with REF1 pin and REF2 pin
- V_{OFFSET} is the intermediate voltage with OFFSET pin

Also, V_{OUT} needs to be $GND < V_{OUT} < V_{DD}$.

V_{OUT} is clipped to Low-level Output Voltage (V_{OUT_L}) when it's under GND.

V_{OUT} is clipped to High-level Output Voltage (V_{OUT_H}) when it's over V_{DD} .

To accurately sense the current through the shunt resistor, it is necessary to use a 4-terminal Kelvin connection to avoid errors in the impedance of the current path.

For stability, dispose and connect a bypass capacitor for removing power source noise close to IC.

Selection of shunt resistor

Shunt resistor R_{SHUNT} should be selected considering the accuracy of measuring current and the maximum power dissipation according to an application.

If the value of shunt resistor is high, it minimizes the influence of offset and increases the accuracy of measuring current.

If the value of shunt resistor is low, it reduces the power dissipation of V_{DD} .

I/O Equivalence Circuits

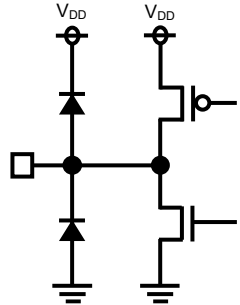
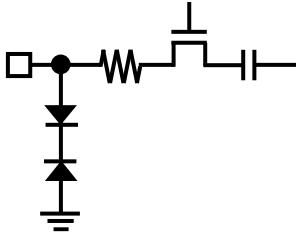
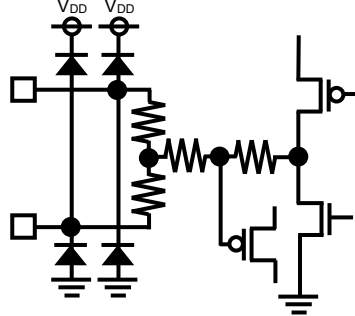
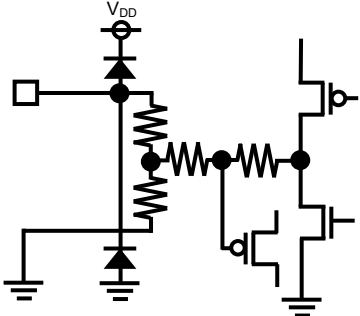
Pin Name	Equivalence Circuit Diagram	Pin Name	Equivalence Circuit Diagram
OUT		VINP VINM	
REF1 REF2		OFFSET	

Operational Notes

1. Reverse Connection of Power Supply

Connecting the power supply in reverse polarity can damage the IC. Take precautions against reverse polarity when connecting the power supply, such as mounting an external diode between the power supply and the IC's power supply pins.

2. Power Supply Lines

Design the PCB layout pattern to provide low impedance supply lines. Furthermore, connect a capacitor to ground at all power supply pins. Consider the effect of temperature and aging on the capacitance value when using electrolytic capacitors.

3. Ground Voltage

Ensure that no pins are at a voltage below that of the ground pin at any time, even during transient condition.

4. Ground Wiring Pattern

When using both small-signal and large-current ground traces, the two ground traces should be routed separately but connected to a single ground at the reference point of the application board to avoid fluctuations in the small-signal ground caused by large currents. Also ensure that the ground traces of external components do not cause variations on the ground voltage. The ground lines must be as short and thick as possible to reduce line impedance.

5. Recommended Operating Conditions

The function and operation of the IC are guaranteed within the range specified by the recommended operating conditions. The characteristic values are guaranteed only under the conditions of each item specified by the electrical characteristics.

6. Inrush Current

When power is first supplied to the IC, it is possible that the internal logic may be unstable and inrush current may flow instantaneously due to the internal powering sequence and delays, especially if the IC has more than one power supply. Therefore, give special consideration to power coupling capacitance, power wiring, width of ground wiring, and routing of connections.

7. Testing on Application Boards

When testing the IC on an application board, connecting a capacitor directly to a low-impedance output pin may subject the IC to stress. Always discharge capacitors completely after each process or step. The IC's power supply should always be turned off completely before connecting or removing it from the test setup during the inspection process. To prevent damage from static discharge, ground the IC during assembly and use similar precautions during transport and storage.

8. Inter-pin Short and Mounting Errors

Ensure that the direction and position are correct when mounting the IC on the PCB. Incorrect mounting may result in damaging the IC. Avoid nearby pins being shorted to each other especially to ground, power supply and output pin. Inter-pin shorts could be due to many reasons such as metal particles, water droplets (in very humid environment) and unintentional solder bridge deposited in between pins during assembly to name a few.

9. Unused Input Pins

Input pins of an IC are often connected to the gate of a MOS transistor. The gate has extremely high impedance and extremely low capacitance. If left unconnected, the electric field from the outside can easily charge it. The small charge acquired in this way is enough to produce a significant effect on the conduction through the transistor and cause unexpected operation of the IC. So unless otherwise specified, unused input pins should be connected to the power supply or ground line.

Operational Notes - continued

10. Regarding the Input Pin of the IC

This monolithic IC contains P+ isolation and P substrate layers between adjacent elements in order to keep them isolated. P-N junctions are formed at the intersection of the P layers with the N layers of other elements, creating a parasitic diode or transistor. For example (refer to figure below):

- When GND > Pin A and GND > Pin B, the P-N junction operates as a parasitic diode.
- When GND > Pin B, the P-N junction operates as a parasitic transistor.

Parasitic diodes inevitably occur in the structure of the IC. The operation of parasitic diodes can result in mutual interference among circuits, operational faults, or physical damage. Therefore, conditions that cause these diodes to operate, such as applying a voltage lower than the GND voltage to an input pin (and thus to the P substrate) should be avoided.

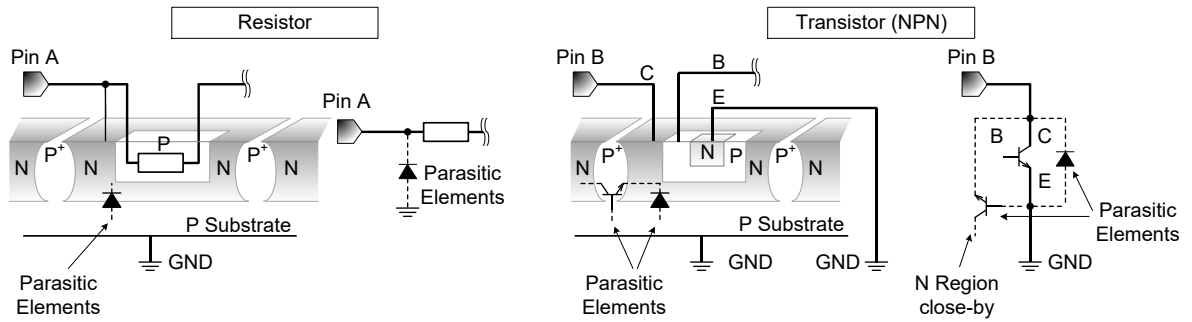
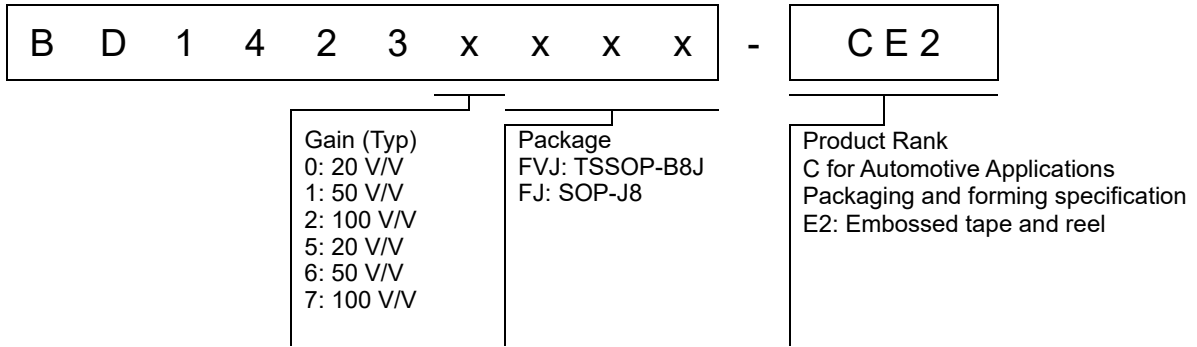

Figure 12. Example of Monolithic IC Structure

11. Ceramic Capacitor

When using a ceramic capacitor, determine a capacitance value considering the change of capacitance with temperature and the decrease in nominal capacitance due to DC bias and others.

Ordering Information



Marking Diagram

TSSOP-B8J (TOP VIEW)

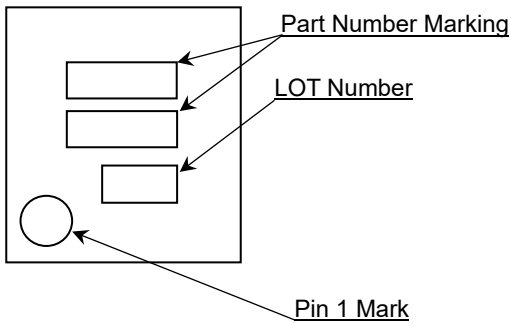

SOP-J8 (TOP VIEW)

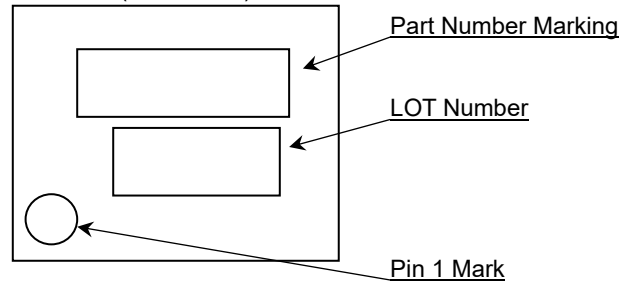

Part Number Marking	Package	Orderable Part Number
D14230	TSSOP-B8J	BD14230FVJ-CE2
D14231		BD14231FVJ-CE2
D14232		BD14232FVJ-CE2
14230	SOP-J8	BD14230FJ-CE2
14231		BD14231FJ-CE2
14232		BD14232FJ-CE2
14235		BD14235FJ-CE2
14236		BD14236FJ-CE2
14237		BD14237FJ-CE2

Physical Dimension and Packing Information

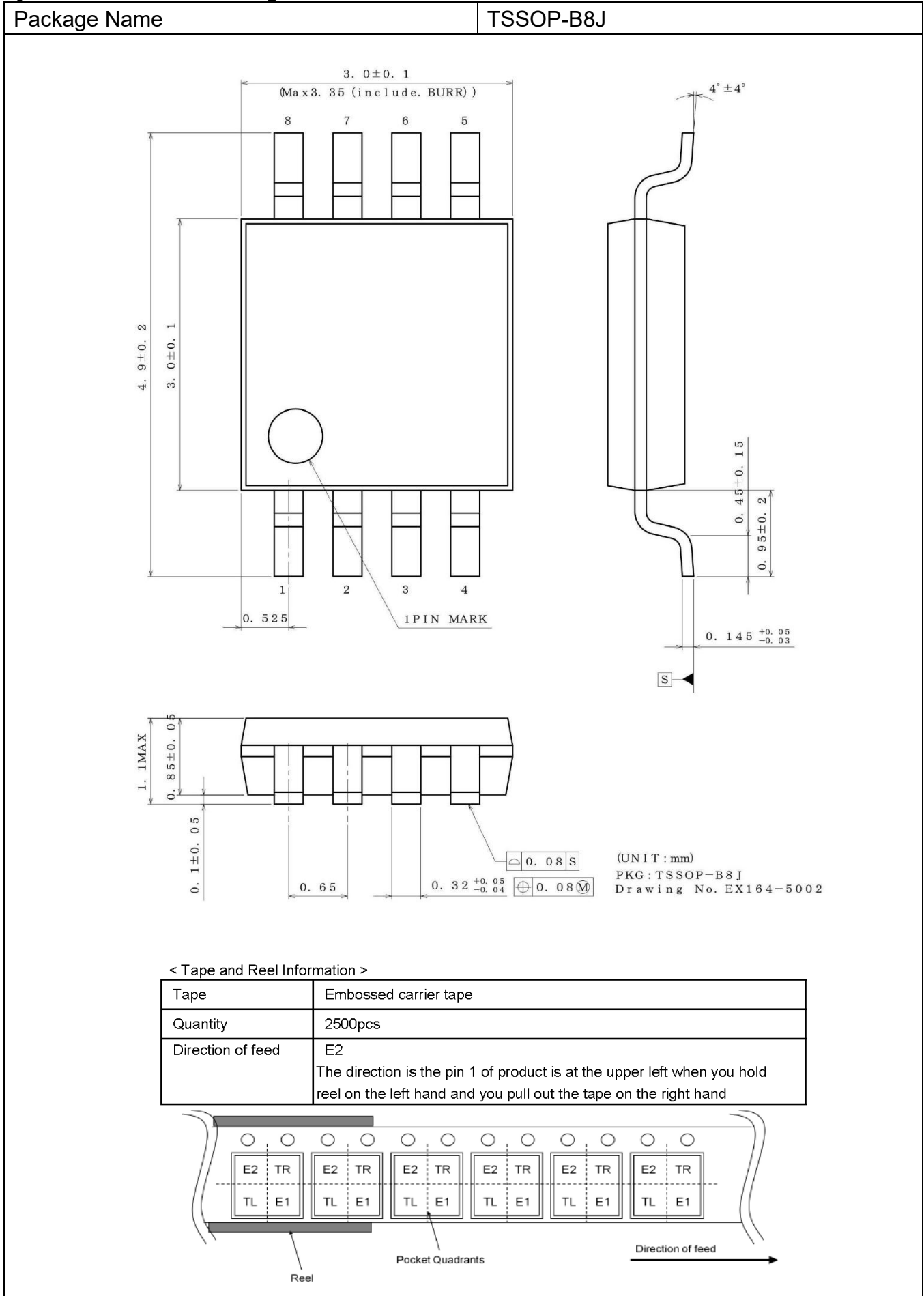

Physical Dimension and Packing Information - continued

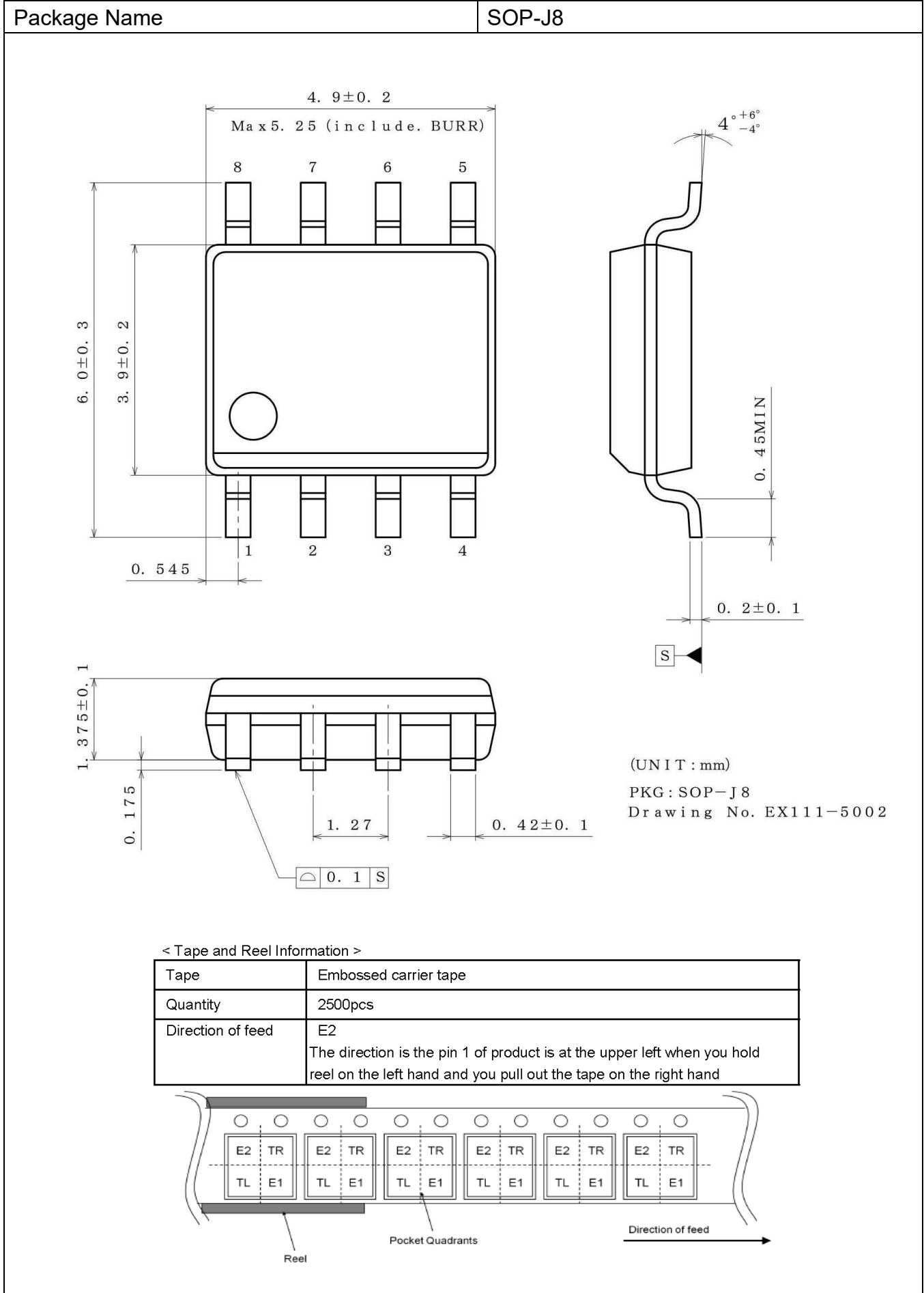

Revision History

Date	Revision	Changes
17.Nov.2023	001	New Release
03.Apr.2025	002	Added package lineup Absolute maximum rating supply voltage changed from 18 V to 18.2 V

Notice

Precaution on using ROHM Products

1. If you intend to use our Products in devices requiring extremely high reliability (such as medical equipment ^(Note 1), aircraft/spacecraft, nuclear power controllers, etc.) and whose malfunction or failure may cause loss of human life, bodily injury or serious damage to property ("Specific Applications"), please consult with the ROHM sales representative in advance. Unless otherwise agreed in writing by ROHM in advance, ROHM shall not be in any way responsible or liable for any damages, expenses or losses incurred by you or third parties arising from the use of any ROHM's Products for Specific Applications.

(Note1) Medical Equipment Classification of the Specific Applications

JAPAN	USA	EU	CHINA
CLASS III	CLASS III	CLASS II b	CLASS III
CLASS IV		CLASS III	

2. ROHM designs and manufactures its Products subject to strict quality control system. However, semiconductor products can fail or malfunction at a certain rate. Please be sure to implement, at your own responsibilities, adequate safety measures including but not limited to fail-safe design against the physical injury, damage to any property, which a failure or malfunction of our Products may cause. The following are examples of safety measures:
 - [a] Installation of protection circuits or other protective devices to improve system safety
 - [b] Installation of redundant circuits to reduce the impact of single or multiple circuit failure
3. Our Products are not designed under any special or extraordinary environments or conditions, as exemplified below. Accordingly, ROHM shall not be in any way responsible or liable for any damages, expenses or losses arising from the use of any ROHM's Products under any special or extraordinary environments or conditions. If you intend to use our Products under any special or extraordinary environments or conditions (as exemplified below), your independent verification and confirmation of product performance, reliability, etc. prior to use, must be necessary:
 - [a] Use of our Products in any types of liquid, including water, oils, chemicals, and organic solvents
 - [b] Use of our Products outdoors or in places where the Products are exposed to direct sunlight or dust
 - [c] Use of our Products in places where the Products are exposed to sea wind or corrosive gases, including Cl₂, H₂S, NH₃, SO₂, and NO₂
 - [d] Use of our Products in places where the Products are exposed to static electricity or electromagnetic waves
 - [e] Use of our Products in proximity to heat-producing components, plastic cords, or other flammable items
 - [f] Sealing or coating our Products with resin or other coating materials
 - [g] Use of our Products without cleaning residue of flux (Exclude cases where no-clean type fluxes is used. However, recommend sufficiently about the residue.); or Washing our Products by using water or water-soluble cleaning agents for cleaning residue after soldering
 - [h] Use of the Products in places subject to dew condensation
4. The Products are not subject to radiation-proof design.
5. Please verify and confirm characteristics of the final or mounted products in using the Products.
6. In particular, if a transient load (a large amount of load applied in a short period of time, such as pulse, is applied, confirmation of performance characteristics after on-board mounting is strongly recommended. Avoid applying power exceeding normal rated power; exceeding the power rating under steady-state loading condition may negatively affect product performance and reliability.
7. De-rate Power Dissipation depending on ambient temperature. When used in sealed area, confirm that it is the use in the range that does not exceed the maximum junction temperature.
8. Confirm that operation temperature is within the specified range described in the product specification.
9. ROHM shall not be in any way responsible or liable for failure induced under deviant condition from what is defined in this document.

Precaution for Mounting / Circuit board design

1. When a highly active halogenous (chlorine, bromine, etc.) flux is used, the residue of flux may negatively affect product performance and reliability.
2. In principle, the reflow soldering method must be used on a surface-mount products, the flow soldering method must be used on a through hole mount products. If the flow soldering method is preferred on a surface-mount products, please consult with the ROHM representative in advance.

For details, please refer to ROHM Mounting specification

Precautions Regarding Application Examples and External Circuits

1. If change is made to the constant of an external circuit, please allow a sufficient margin considering variations of the characteristics of the Products and external components, including transient characteristics, as well as static characteristics.
2. You agree that application notes, reference designs, and associated data and information contained in this document are presented only as guidance for Products use. Therefore, in case you use such information, you are solely responsible for it and you must exercise your own independent verification and judgment in the use of such information contained in this document. ROHM shall not be in any way responsible or liable for any damages, expenses or losses incurred by you or third parties arising from the use of such information.

Precaution for Electrostatic

This Product is electrostatic sensitive product, which may be damaged due to electrostatic discharge. Please take proper caution in your manufacturing process and storage so that voltage exceeding the Products maximum rating will not be applied to Products. Please take special care under dry condition (e.g. Grounding of human body / equipment / solder iron, isolation from charged objects, setting of Ionizer, friction prevention and temperature / humidity control).

Precaution for Storage / Transportation

1. Product performance and soldered connections may deteriorate if the Products are stored in the places where:
 - [a] the Products are exposed to sea winds or corrosive gases, including Cl₂, H₂S, NH₃, SO₂, and NO₂
 - [b] the temperature or humidity exceeds those recommended by ROHM
 - [c] the Products are exposed to direct sunshine or condensation
 - [d] the Products are exposed to high Electrostatic
2. Even under ROHM recommended storage condition, solderability of products out of recommended storage time period may be degraded. It is strongly recommended to confirm solderability before using Products of which storage time is exceeding the recommended storage time period.
3. Store / transport cartons in the correct direction, which is indicated on a carton with a symbol. Otherwise bent leads may occur due to excessive stress applied when dropping of a carton.
4. Use Products within the specified time after opening a humidity barrier bag. Baking is required before using Products of which storage time is exceeding the recommended storage time period.

Precaution for Product Label

A two-dimensional barcode printed on ROHM Products label is for ROHM's internal use only.

Precaution for Disposition

When disposing Products please dispose them properly using an authorized industry waste company.

Precaution for Foreign Exchange and Foreign Trade act

Since concerned goods might be fallen under listed items of export control prescribed by Foreign exchange and Foreign trade act, please consult with ROHM in case of export.

Precaution Regarding Intellectual Property Rights

1. All information and data including but not limited to application example contained in this document is for reference only. ROHM does not warrant that foregoing information or data will not infringe any intellectual property rights or any other rights of any third party regarding such information or data.
2. ROHM shall not have any obligations where the claims, actions or demands arising from the combination of the Products with other articles such as components, circuits, systems or external equipment (including software).
3. No license, expressly or implied, is granted hereby under any intellectual property rights or other rights of ROHM or any third parties with respect to the Products or the information contained in this document. Provided, however, that ROHM will not assert its intellectual property rights or other rights against you or your customers to the extent necessary to manufacture or sell products containing the Products, subject to the terms and conditions herein.

Other Precaution

1. This document may not be reprinted or reproduced, in whole or in part, without prior written consent of ROHM.
2. The Products may not be disassembled, converted, modified, reproduced or otherwise changed without prior written consent of ROHM.
3. In no event shall you use in any way whatsoever the Products and the related technical information contained in the Products or this document for any military purposes, including but not limited to, the development of mass-destruction weapons.
4. The proper names of companies or products described in this document are trademarks or registered trademarks of ROHM, its affiliated companies or third parties.

General Precaution

1. Before you use our Products, you are requested to carefully read this document and fully understand its contents. ROHM shall not be in any way responsible or liable for failure, malfunction or accident arising from the use of any ROHM's Products against warning, caution or note contained in this document.
2. All information contained in this document is current as of the issuing date and subject to change without any prior notice. Before purchasing or using ROHM's Products, please confirm the latest information with a ROHM sales representative.
3. The information contained in this document is provided on an "as is" basis and ROHM does not warrant that all information contained in this document is accurate and/or error-free. ROHM shall not be in any way responsible or liable for any damages, expenses or losses incurred by you or third parties resulting from inaccuracy or errors of or concerning such information.