



# Oven Controlled Crystal Oscillator (OCXO)

## ■ NH25M22WG Data Sheet

### Main Application

- Base stations for system mobile communications (5G CU, DU, 4G BBU)
- IEEE1588, Synchronous Ethernet clock (SyncE)
- Optical transmission systems Stratum 3E
- Frequency synthesizer
- GNSS-DO
- Timing and synchronous measuring equipment
- High resolution audio clock

### Features

- Low power consumption.
- Excellent stabilization time characteristics.
- Excellent long-term frequency stability.
- Excellent phase noise characteristics.
- Dimension : 25.4 × 22 × 12.1 mm

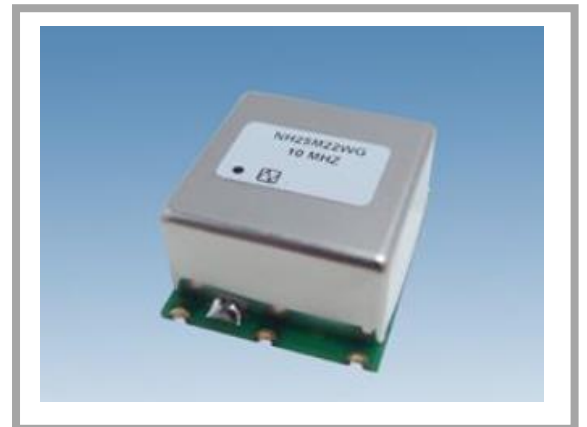

**RoHS Compliant**  
Directive 2011/65/EU  
Directive (EU) 2015/863

1. Item : Oven Controlled Crystal Oscillator (OCXO)
2. Type : NH25M22WG
3. Nominal Frequency: 10 MHz
4. NDK Spec. No. : NSC5127[A, B], NSC5128[A, B]  
Please refer to sections 5 and 6 as the ratings and electrical specifications change depending on NDK spec No.
5. Rating

Parameters	Sym.	Spec.				Notes
		Min.	Typ.	Max.	Units	
5.1 Nominal Frequency	$f_{nom}$	10			MHz	
5.2 Supply Voltage	$V_{CC}$	+3.135	+3.3	+3.465	V	NSC5127[A, B]
		+4.75	+5.0	+5.25	V	NSC5128[A, B]
5.3 Control Voltage	$V_{cont}$	0	+1.4	+2.8	V	NSC5127A
		0	+1.65	+3.3	V	NSC5127B
		0	+2.0	+4.0	V	NSC5128A
		0	+2.5	+5.0	V	NSC5128B
5.4 Load	$C_L$	-	15	-	pF	
5.5 Operating Temperature Range	$T_{opr}$	0	-	+70	°C	NSC5127A, NSC5128A
		-40	-	+85	°C	NSC5127B, NSC5128B
5.6 Storage Temperature Range	$T_{str}$	-40	-	+85	°C	

## 6. Electrical Specifications

Unless otherwise specified, meaning condition.  $T = +25\text{ °C}$ ,  $V_{CC} = \text{Center}$ ,  $V_{cont} = \text{Center}$ ,  $C_L = 15\text{ pF}$

Parameters	Sym.	Spec.				Conditions
		Min.	Typ.	Max.	Units	
6.1 Power Consumption						
6.1.1 During Warm-up	$P_{CC}$	-	-	3.0	W	$T = +25\text{ °C}$
6.1.2 Steady State	$P_{CC}$	-	-	1.3	W	
6.2 Frequency Stability						
6.2.1 Frequency Tolerance	$\Delta f/f_{nom}$	-200	-	+200	ppb	(*1)
6.2.2 Frequency/ Temperature Characteristics	$\Delta f/f$	-10	-	+10	ppb	at Operating Temperature Range (*2)
6.2.3 Frequency/Voltage Coefficient	$\Delta f/f$	-3	-	+3	ppb	$V_{CC} = \text{Center} \pm 5\%$ (*2)
6.2.4 Long-term Frequency stability	$\Delta f/f$	-1	-	+1	ppb	1 day (*3)
		-50	-	+50	ppb	1 year (*3)
6.2.5 Stabilization Time	-	-	-	3	min.	(*4)

Parameters	Sym.	Spec.				Conditions
		Min.	Typ.	Max.	Units	
6.3	Frequency Control					
6.3.1	-	Positive Slope				-
6.3.2	$\Delta f/f$	-	-	-0.5	ppm	$V_{cont} = \text{Min. (*2)}$
		+0.5	-	-	ppm	$V_{cont} = \text{Max. (*2)}$
6.4	Output Characteristics					
6.4.1	-	CMOS (Square wave)				
6.4.2	Output Voltage					
High Level Output Voltage	$V_{OH}$	+2.4	-	-	V	NSC5127[A, B], NSC5128B
Low Level Output Voltage	$V_{OL}$	-	-	+0.4	V	
High Level Output Voltage	$V_{OH}$	+4.5	-	-	V	NSC5128A
Low Level Output Voltage	$V_{OL}$	-	-	+0.5	V	
6.4.3	-	40	-	60	%	at $(V_{OH} + V_{OL})/2$
6.5	Phase Noise at 10 MHz					
	L(f)	-	-100	-	dBc/Hz	1 Hz offset
		-	-125	-	dBc/Hz	10 Hz offset
		-	-142	-	dBc/Hz	100 Hz offset
		-	-152	-	dBc/Hz	1 kHz offset
		-	-152	-	dBc/Hz	10 kHz offset

(\*1)  $\Delta f/f_{nom}$  : Frequency shift from nominal frequency.

(\*2)  $\Delta f/f$ : Frequency shift from the reference frequency. T = +25 °C,  $V_{CC} = +$  Center,  $V_{cont} =$  Center,  $C_L = 15$  pF

(\*3) Based on frequency after 30 days operation.

(\*4) Within  $\pm 200$  ppb, based on frequency after 60 minutes. T = +25 °C.

(\*5) Typ. value is for reference only.

Stabilization Time

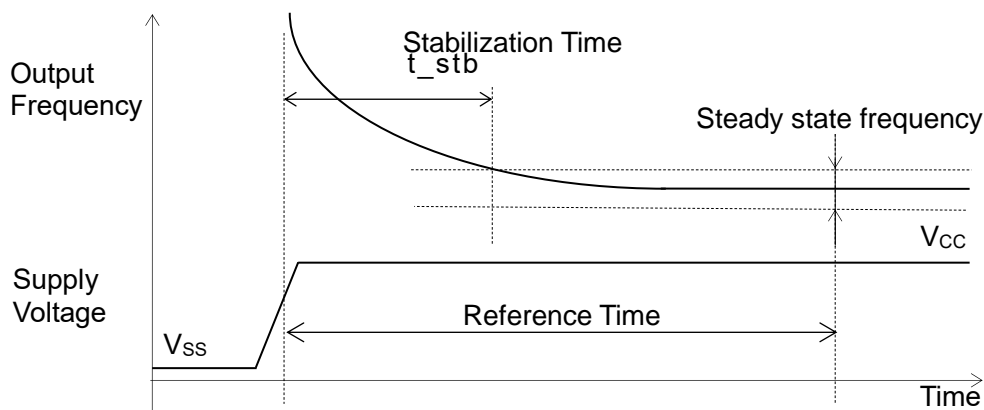

Waveform

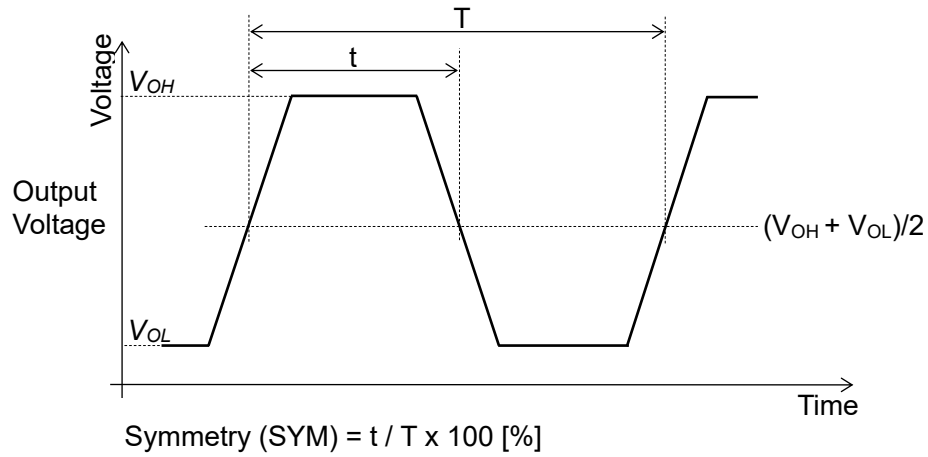

7. Marking

- 7.1 NDK Spec. No.
- 7.2 Nominal Frequency
- 7.3 Serial Number
- 7.4 Manufacture Date
- 7.5 NDK Symbol mark

It might be printed NDK management code to the oscillator bottom by the laser trimming.

8. Moisture Sensitive Level : Level 3

9. Recommended Measurement Circuit

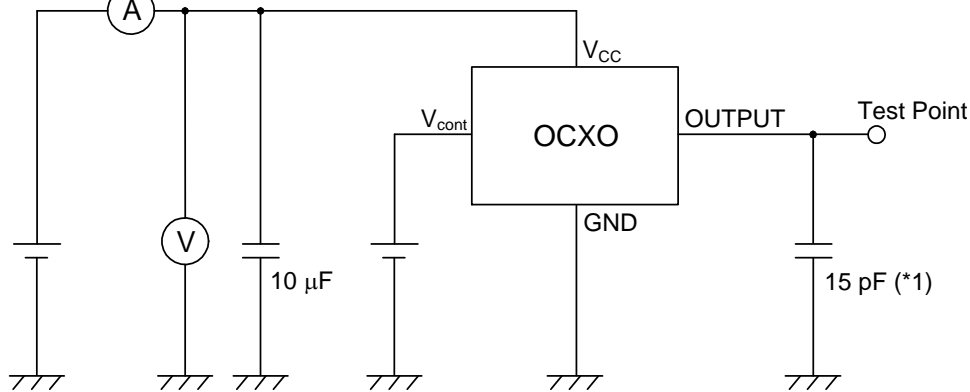

(\*1) Including capacitance of measurement jig and probe

10. Mount condition

Be sure to use the product under the following conditions. Otherwise, the characteristics deterioration or destruction of the product may result.

[Reflow soldering, Flow soldering heat resistance]

- Preheating: 150 °C to 200 °C, 60 to 120 s
  - Ramp up rate: Max. 3 °C/s
  - Heating: 217 °C or higher, 30 to 90 s
  - Peak temperature: 245 °C, +0/-5 °C
  - Time within 5 °C of Peak temperature: < 30 s
  - Reflow passage times: twice
- In reflowing, the turning over of mounted boards shall be forbidden.

[Hand soldering heat resistance]

Press a soldering iron of 350 °C on the lead electrode for five seconds (twice).

## 11. ESD

- Machine Model (MM)

Max. +/-200 V (Standards JESD22-A115)

- Human Body Model (HBM)

Max. +/-2000 V (Standards JESD22-A114)

- Charged Device Model (CDM)

Max. +/-500 V (Standards JESD22-C101)

## 12. Prohibited items

12.1 OCXO is designed to keep the performance by continuous operation. Therefore, please avoid use of OCXO which repeats ON-OFF of a power supply frequently.

12.2 Since the DNC terminal is a terminal used for our adjustment, etc., there is a possibility that an abnormality may occur in OCXO due to signal input. Do not connect to a DNC terminal.

■ Dimension of External

Unit : mm

Tolerance :  $\pm 0.2$

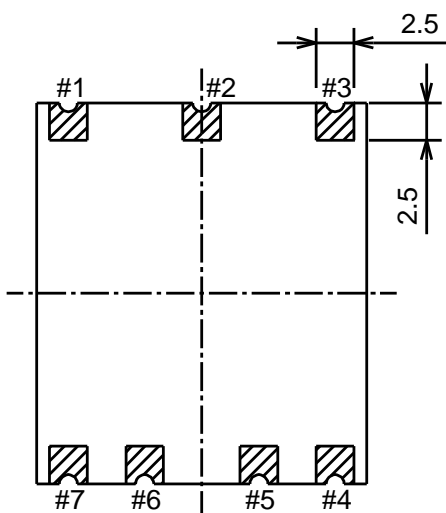
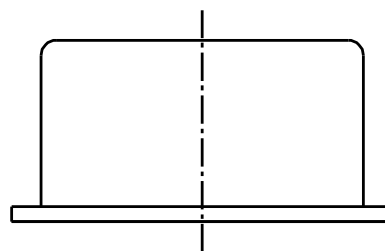
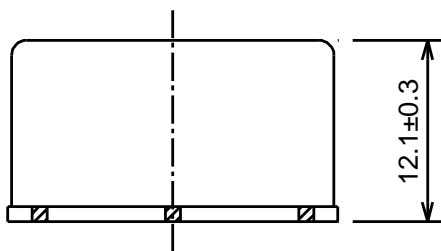
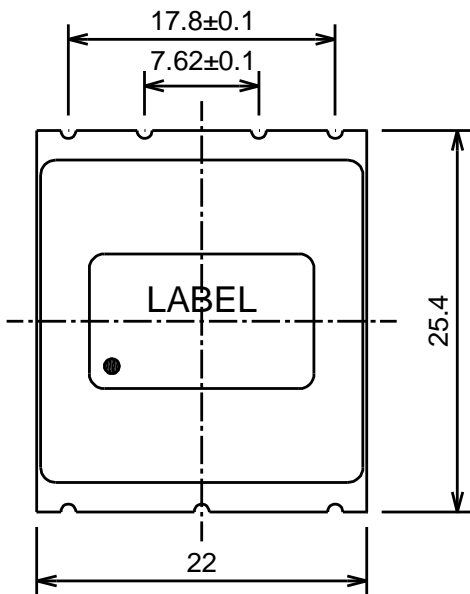

■ Terminal Function

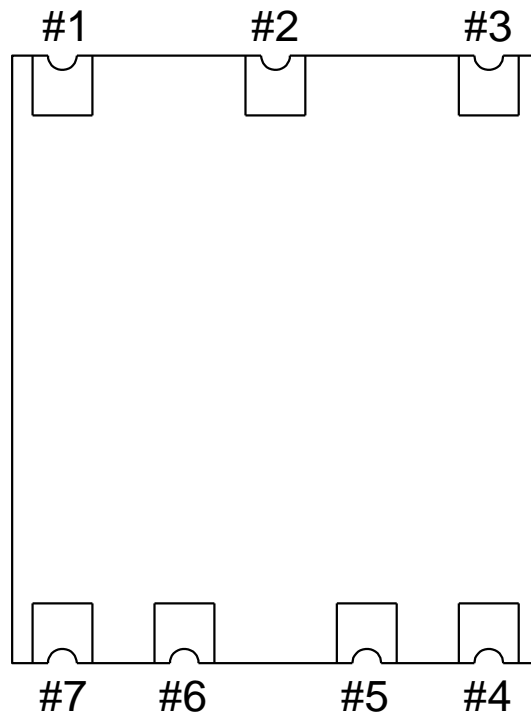

Pin connections	
#1	$V_{cont}$
#2	DNC (Don't connect)
#3	$V_{CC}$
#4	OUTPUT
#5	DNC (Don't connect)
#6	DNC (Don't connect)
#7	GND

■ Recommended Land Pattern

Unit : mm

Tolerance :  $\pm 0.1$

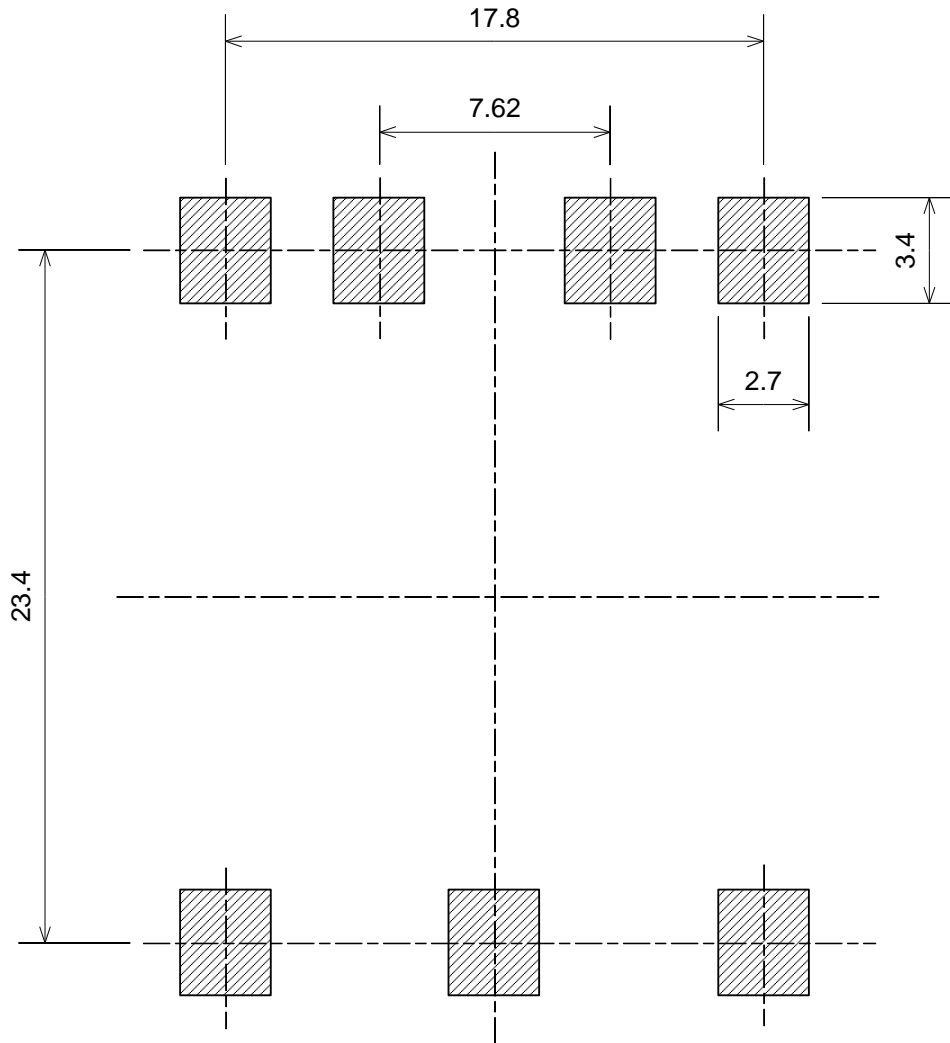

■ Taping and Reel Spec.

Storage quantity : MAX 100 PCS

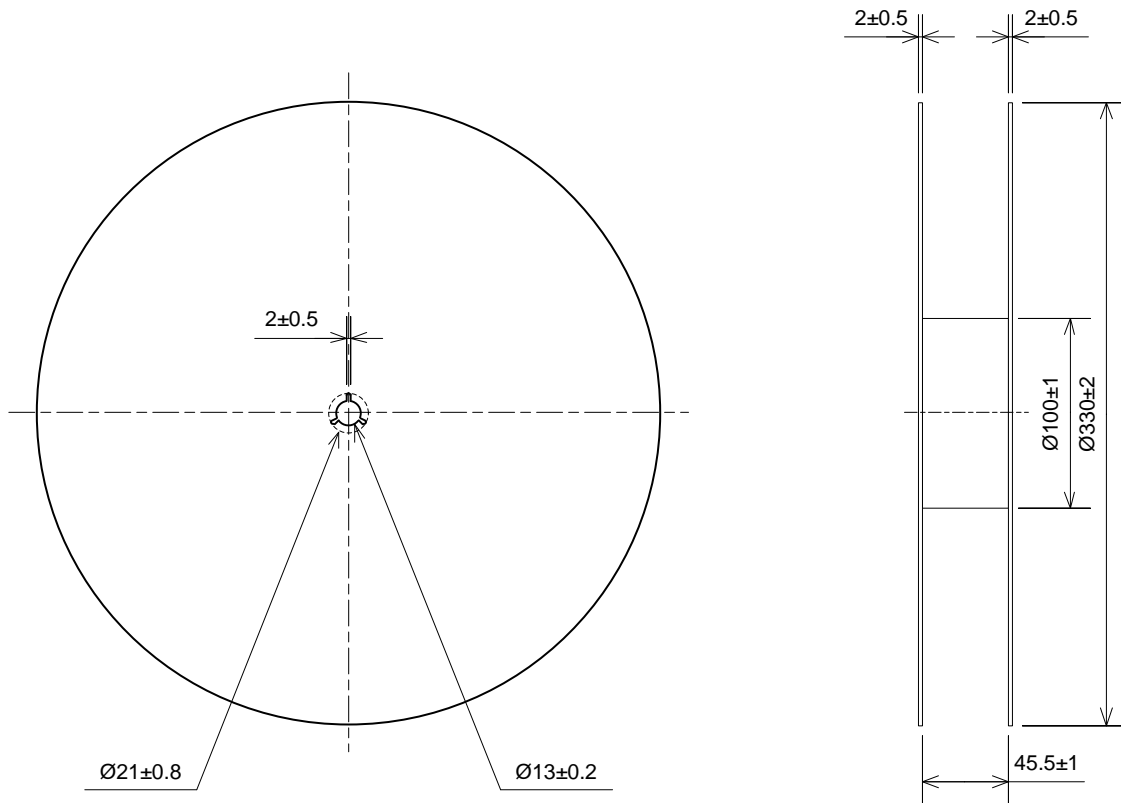

	リール/Reel
材料/Materials	ポリスチレン/PS
性質/Disposition	静電防止/Antistatic

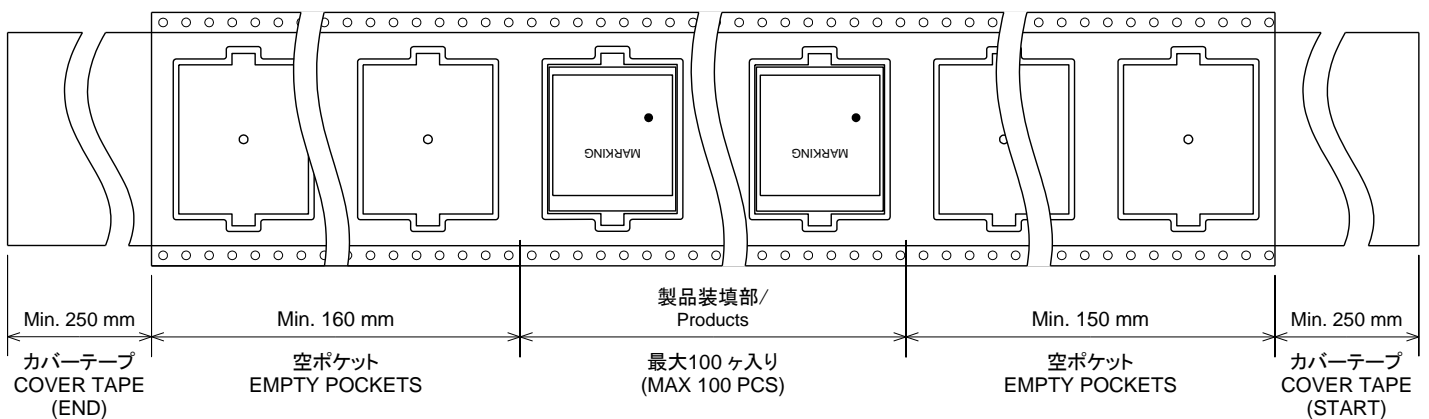

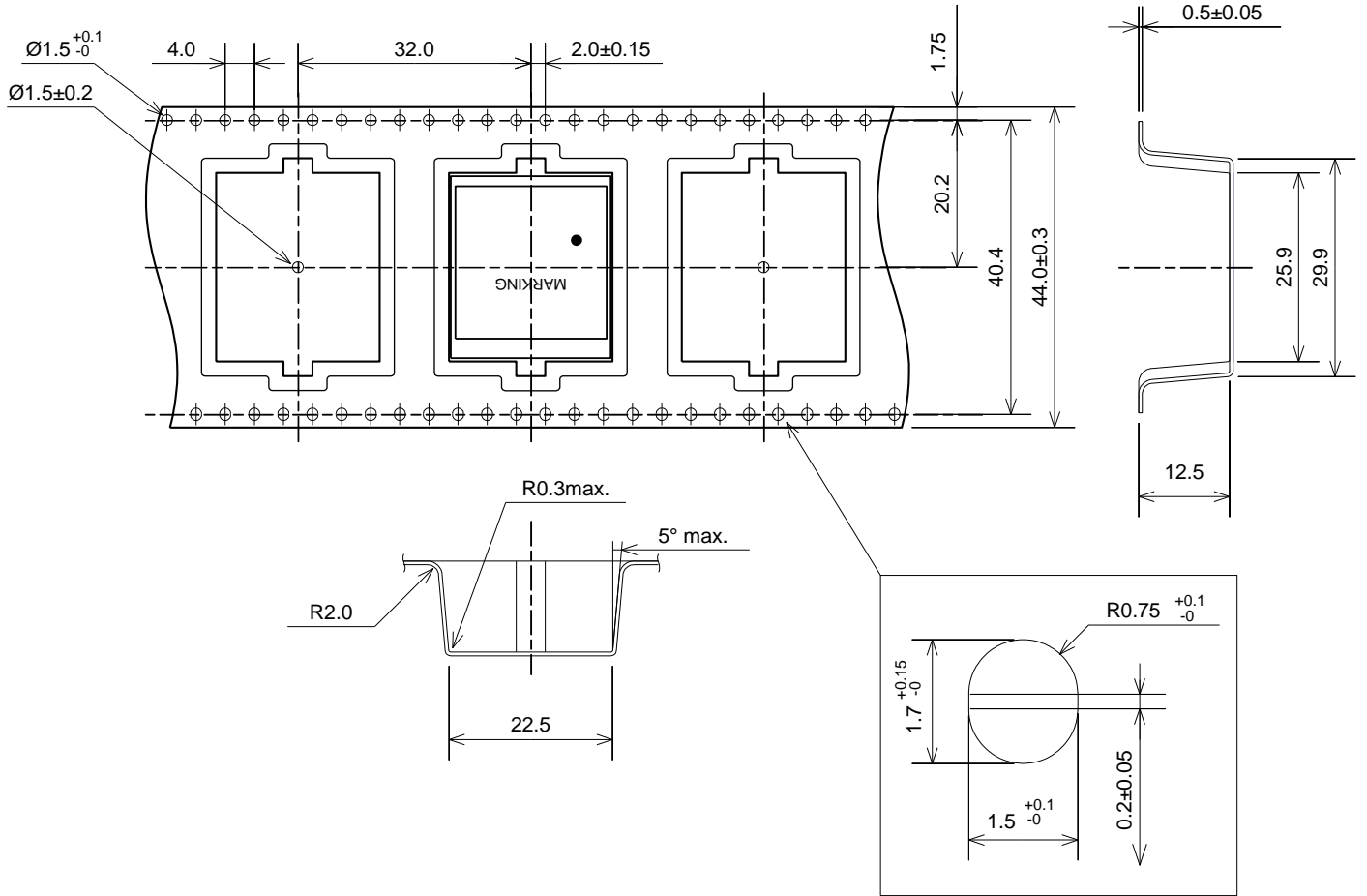

	キャリアテープ/Embossed carrier tape	カバーテープ/Top cover tape
材料/Materials	ポリスチレン+カーボン/PS+Carbon	ポリスチレン/PS
性質/Disposition	導電性/Conductivity	静電防止/Antistatic

#### Handling precautions

1. Please do not add strong shock to the oscillator. In the time of transportation or installing the equipment, please do not drop or add shock to it. If strong shock is added, it may not operate normally. In that case, please use it after checking the characteristics.
2. Because of Oven Controlled Crystal Oscillator (OCXO), please do not place this product near heat sources, signal and noise sources that may affect the oscillator, and transmitter-receivers.
3. In OCXO, It is not recommended that some metal like a heat sink is placed on it directly, which is controlled by a specific high temperature, so that the characteristics cause unstable temperature control. Moreover, the ambient wind could affect characteristics by the same reason. The characteristic degradation by changing may occur according to ambient environment in the low temperature especially. Therefore, in the case of use of these products, please kindly do sufficient evaluation in advance on your side.
4. After soldering process, OCXO's characteristics may not be stable immediately because internal parts are influenced by the heat when soldering. For that reason, please avoid immediately using of these products after soldering and evaluate sufficiently in advance on your side.
5. If GND impedance of wiring pattern is high, OCXO's characteristics may not be stable because current consumption of OCXO greatly changes by the ambient temperature. In the case of use of these products, please kindly design GND impedance of wiring pattern to be sufficiently lower.
6. Placement of this product within the influenced area by magnetic field is not recommended because it may be affected magnetically. In the case of use of these products in such a situation, please kindly do sufficient evaluation in advance on your side.

#### Notes on use

1. Even if the appearance color etc. of the product differs by purchasing the component parts by more than two companies, there is no influence on the characteristics and reliability.
2. IN THE CASE OF THE FOLLOWING ITEMS, WE ARE NOT RESPONSIBLE FOR WARRANTY / COMPENSATION.
  - (1) WHEN PRODUCTS OF THIS SPECIFICATION ARE USED FOR EQUIPMENT RELATED TO HUMAN LIFE OR PROPERTY, IT IS THE RESPONSIBILITY OF THE CUSTOMER TO CONFIRM THE INFLUENCE ON THIS PRODUCT AND EQUIPMENT TO BE USED BEFOREHAND, CONDUCT NECESSARY SAFETY DESIGN (INCLUDING REDUNDANT DESIGN, MALFUNCTION PREVENTION DESIGN, etc.), PLEASE USE IT AFTER SECURING SUFFICIENT SAFETY OF EQUIPMENT.
    - 1.SAFETY-RELATED EQUIPMENT SUCH AS AUTOMOBILES, TRAINS, SHIPS, etc., OR EQUIPMENT DIRECTLY INVOLVED IN OPERATION
    - 2.AIRCRAFT EQUIPMENT
    - 3.SPACE EQUIPMENT
    - 4.MEDICAL EQUIPMENT
    - 5.MILITARY EQUIPMENT
    - 6.DISASTER PREVENTION / CRIME PREVENTION EQUIPMENT
    - 7.TRAFFIC LIGHT
    - 8.OTHER EQUIPMENT REQUIRING THE SAME PERFORMANCE AS THE ABOVE-MENTIONED EQUIPMENT
  - (2) IN CASES WHERE IT IS NOT INDICATED IN THE REQUESTED STANDARD AND IS USED UNDER CONDITIONS OF USE (INCLUDING CIRCUIT MARGIN etc.) THAT CAN NOT BE PREDICTED AT THE PRODUCTION STAGE.
  - (3) WHEN USING ULTRASONIC WELDING MACHINE. (THERE IS A POSSIBILITY THAT THE CHARACTERISTIC DEGRADATION IS CAUSED BY THE RESONANCE PHENOMENON OF THE PIEZOELECTRIC MATERIAL.(EXAMPLE; CRYSTAL PIECE))

WE WILL NOT TAKE ANY RESPONSIBILITY FOR THE INFLUENCE OF THE CUSTOMERS' PROCESS.

SO, PLEASE SUFFICIENTLY EVALUATE AT A SAMPLE STEP WHEN YOU USE ULTRASONIC WELDING MACHINE.

(4) USING RESIN MOLD MAY AFFECT THE PRODUCT CHARACTERISTIC.

PLEASE MAKE SURE TO TELL OUR SALES CONTACT WHEN YOU USE RESIN MOLD. WE WILL PERFORM INDIVIDUAL CORRESPONDENCE ABOUT A DELIVERY SPECIFICATION AND AN EVALUATION METHOD.

IN ADDITION, IF YOU USE RESIN MOLD WITHOUT CONTACTING US, AND CAUSES DAMAGES AGAINST A CUSTOMER OR A THIRD PARTY, WE WILL NOT BE LIABLE FOR THE DAMAGES AND OTHER RESPONSIBILITIES BECAUSE WE CONSIDER IT IS UNDER SELF-RESPONSIBILITY USING RESIN MOLD.

WE WILL NOT TAKE ANY RESPONSIBILITY FOR THE INFLUENCE OF THE CUSTOMERS' PROCESS. PLEASE EFFICIENTLY EVALUATE AT A SAMPLE STEP WHEN YOU USE RESIN MOLD.

(5) WHEN PERFORMING IMPROPER HANDLING THAT EXCEEDS THE GUARANTEED RANGE.

(6) WHEN USING THIS PRODUCT, PLEASE INSERT A BYPASS CAPACITOR BETWEEN THE POWER SUPPLY AND GND.

(CLOSER TO THE PRODUCT TERMINAL IS DESIRABLE.)

THE BYPASS CAPACITOR VALUES SHOWN IN OUR SPECIFICATIONS AND DRAWING ARE FOR REFERENCE ONLY.

(THEY ARE NOT GUARANTEED VALUES.)

IN ACUTUAL USE, PLEASE SELECT THE APPROPRIATE BYPASS CAPACITOR VALUE FOR YOUR CIRCUIT.

NDK SHALL NOT BE LIABLE FOR ANY AND ALL EVENTS RESULTING FROM OR IN CONNECTION WITH THE USE OF THIS PRODUCT IN A MANNER THAT DOES NOT COMPLY WITH THE ABOVE INSTRUCTION.

(7) USING THE PRODUCT AFTER THE PRODUCT STORAGE DEADLINE.

(8) WHEN CONFIRMED THE DEFECT AFTER THE WARRANTY PERIOD.

3. This product can not be used for automotive applications.

Notes on storage etc

1. When storing the product in high temperature and high humidity condition for a long time, product characteristics (solderability etc.) and packaging condition may be deteriorated. Please store product at temperature +5 °C~+35 °C, humidity 85% RH or less. The product is an electronic component, so please do not storage under a dewing state.
2. The product storage deadline is 12 months after from the delivery date in unopened state. Please use within storage deadline. The product warranty period is 12 months form delivery date. IF YOU USE THE PRODUCT BEFORE THE PRODUCT STORAGE DEADLINE, AND IF THE DEFECT IS CONFIRMED WITHIN THE WARRANTY PERIOD, WE WILL EXCLUSIVELY INVESTIGATE THE CAUSE OF THE PROBLEM FREE OF CHARGE AND DELIVER A REPLACEMENT PRODUCT FREE OF CHARGE. IF YOU USE THE PRODUCT AFTER THE PRODUCT STORAGE DEADLINE AND/OR IF THE DEFECT IS CONFIRMED AFTER THE WARRANTY PERIOD, WE WILL HAVE NO RESPONSIBILITY.

Other Requests

1. Please use this specification only for confirmation of the specification of this product.
2. NOTES THAT ARE DESCRIBED IN THIS DOCUMENT, IF YOU DID NOT COMPLY WITH THE PROHIBITIONS, AND OTHER PLEASE, INCLUDING THE FAILURE CORRESPONDENCE OR COMPENSATION OR DAMAGES, WE CAN NOT ASSUME THE RESPONSIBILITY, PLEASE

UNDERSTAND.

3. OUR LIABILITY SHALL BE LIMITED TO AN AMOUNT EQUIVALENT TO THE PRICE OF THE DEFECTIVE QUANTITY OF THE PRODUCT DESCRIBED IN THIS SPECIFICATION.

Handling of this document and other requests

Please refer to the " Site Guidance" on our website for the handling of information contained in this document. (<https://www.ndk.com/en/terms/>)