

## Preface

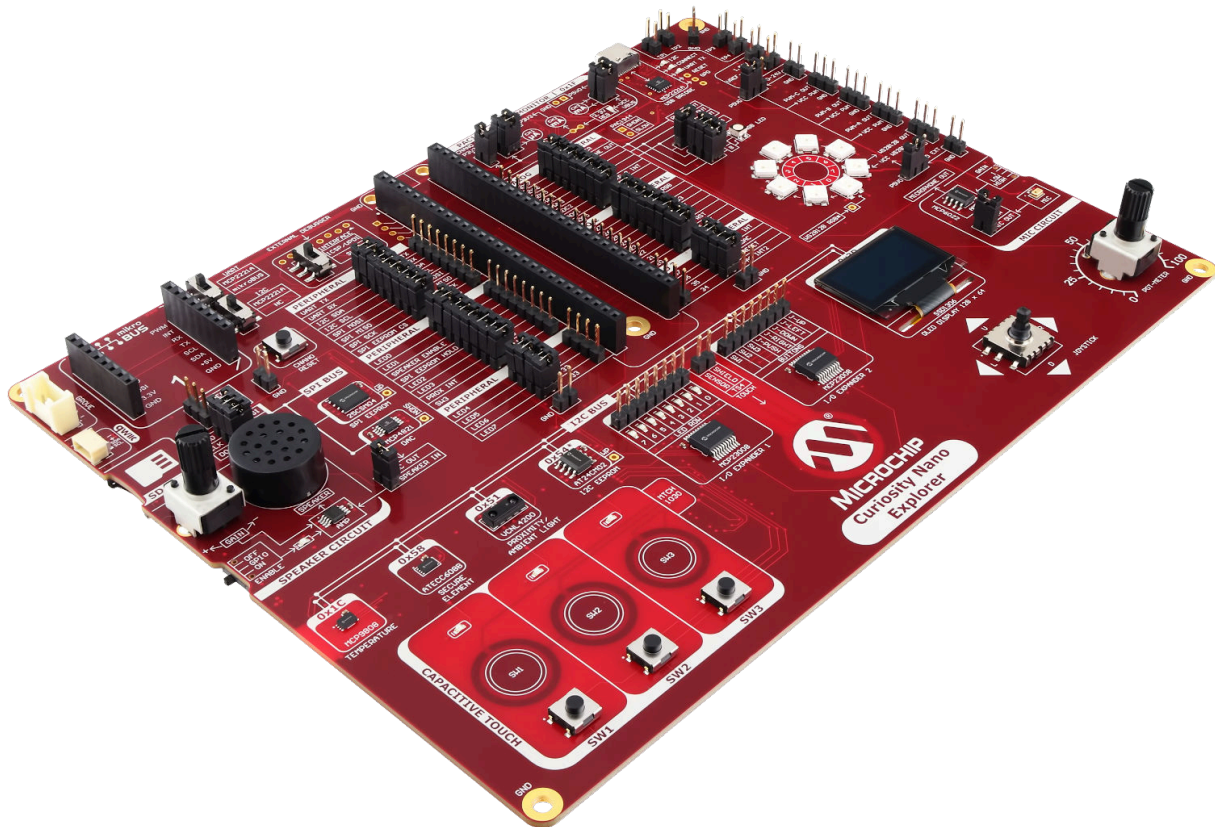

- [Website](#) - Purchase this product, kit information, latest user guide, and design documentation
- [Explorer Pinouts for all Curiosity Nanos](#) - Explorer Pinouts for all Curiosity Nano boards
- [Schematics](#) - Board schematics
- [Altium Project](#) - Altium design files for the latest board revision
- [Design Documentation](#) - Production files for all board revisions
- [MPLAB® Discover](#) - Code examples for Curiosity Nano Explorer



### Important:

This version of the user guide documents Curiosity Nano Explorer **Revision 4**.

- [Identify your product revision](#)

- [Curiosity Nano Explorer Online Errata](#) - Latest revision history and known issues for all board revisions

- [Curiosity Nano Explorer Online User Guide](#) - Access the latest user guide online
- [Curiosity Nano Explorer PDF User Guide](#) - Download the latest PDF version of the user guide

## Table of Contents

Preface.....	1
1. Introduction.....	5
1.1. Curiosity Nano Explorer.....	5
1.2. Kit Contents.....	5
1.3. Terminology.....	5
1.4. Image Legend.....	6
2. Board Overview.....	7
2.1. Block Diagram.....	7
2.2. Board Image.....	8
2.3. Feature List.....	9
3. Pinout and Remapping.....	10
3.1. CNANO Socket Remapping.....	11
3.2. Direct Remapping.....	11
3.3. Custom Test Points.....	12
4. Power Supply and Monitor.....	13
4.1. Power Supply.....	13
4.2. Power Monitor.....	18
5. Buttons and LEDs.....	22
5.1. Digital Addressable LEDs.....	22
5.2. RGB LED.....	23
5.3. LED Row and I/O Expander 1.....	24
5.4. Buttons, Joystick and I/O Expander 2.....	25
5.5. Touch Controller.....	27
5.6. Standalone Touch Button.....	29
5.7. CNANO Reset Button.....	29
6. Serial Communication.....	30
6.1. USB Bridge.....	30
6.2. UART Peripherals.....	31
6.3. I <sup>2</sup> C Peripherals.....	31
6.4. SPI Peripherals.....	36
7. Analog Peripherals.....	39
7.1. Microphone Circuit.....	39
7.2. Speaker Circuit.....	40
7.3. Rotary Potentiometer.....	40
7.4. Voltage Reference.....	41
8. External Connectivity.....	42
8.1. Servomotor Headers.....	42
8.2. MikroBUS™ Socket.....	43
8.3. Grove.....	43

8.4.	Qwiic® .....	44
8.5.	PICKIT™ Header.....	44
9.	Hardware Revision History.....	45
9.1.	Identifying Product ID and Revision.....	45
9.2.	Hardware Revision History and Errata.....	45
9.3.	Document Revision History.....	45
10.	Appendix.....	46
10.1.	MTCH1030 Touch Tune Data.....	46
10.2.	Addressable LEDs Timing and Format.....	47
10.3.	Schematics.....	48
10.4.	Assembly Drawings.....	58
	Microchip Information.....	60
	Trademarks.....	60
	Legal Notice.....	60
	Microchip Devices Code Protection Feature.....	60
	Product Page Links.....	61

## 1. Introduction

Kit Introduction, Kit Contents, Terminology, Image Legend.

### 1.1. Curiosity Nano Explorer

The Curiosity Nano Explorer lives up to its name by providing extensive on-board features that allow users to explore and experiment with the microcontroller peripherals of their Curiosity Nano development board. It also serves as a great platform to become familiar with Microchip's software offerings.

#### A wide selection of input and output options:

- **INPUTS include** Touch and mechanical buttons, a potentiometer, a joystick, a temperature sensor, a proximity sensor, an ambient light sensor, and a microphone
- **OUTPUTS include** LEDs (simple yellow, standard RGB, and WS2812B RGB), an OLED display, and a speaker

#### Solid support for serial communication:

- I<sup>2</sup>C Bus with eight clients
- SPI Bus with three clients
- UART connection

#### Microchip's complementary technologies:

- Touch controller with three touch buttons and a separate touch button for use with microcontrollers featuring a touch peripheral
- ECC608 provides CryptoAuthentication™ features
- Power Monitoring by the PAC1944 enables the measurement of various power domains

Finally, if anything is missing on the Explorer, its functionality can be expanded via the mikroBUS™, Grove or Qwiic® connector.

### 1.2. Kit Contents

The Curiosity Nano Explorer kit contains:

- One Curiosity Nano Explorer development board
- 20 separable 100-mil jumper wires for pin remapping
- Ten additional 100-mil pin jumpers
- One 1x8 (100-mil) right-angled pin header to connect external programmer/debuggers
- One joystick cap

### 1.3. Terminology











This user guide uses the following terminology:











**Table 1-1.** Terminology

Term	Explanation
<b>Explorer</b>	The Curiosity Nano Explorer development board
<b>CNANO</b>	The connected Curiosity Nano development board
<b>CNANO Socket</b>	A socket with two 1x28 100-mil pin header sockets to connect any Curiosity Nano development board to the Curiosity Nano Explorer

## 1.4. Image Legend

The symbols and colors below are used throughout the user guide.

Symbol	Description
	Pin jumper mounted on pin header
	Pin header
	Pin header socket
	Pin header footprint
	Pin header footprint with cut-strap
	Cut-strap (Cut to disconnect - 0603 sized)
	Solder-strap (Add solder blob to connect)
	Circuit simplification
	Connection point
	Click to return to "Board Overview"
	CNANO Socket

Color	Description
	Microcontroller Target MCU or debugger
	Power Power supply component or circuit
	Analog Analog component or circuit
	I <sup>2</sup> C I <sup>2</sup> C connection
	SPI SPI connection
	UART UART connection
	Peripheral Other peripherals, ex. LEDs, buttons
	Touch Capacitive touch
	Pin Mapping Pin labels, net names or pin remapping
	External Connectivity Connectors and headers

## 2. Board Overview

Block Diagram, Board Image, Feature List.

### 2.1. Block Diagram

Figure 2-1. Explorer Overview

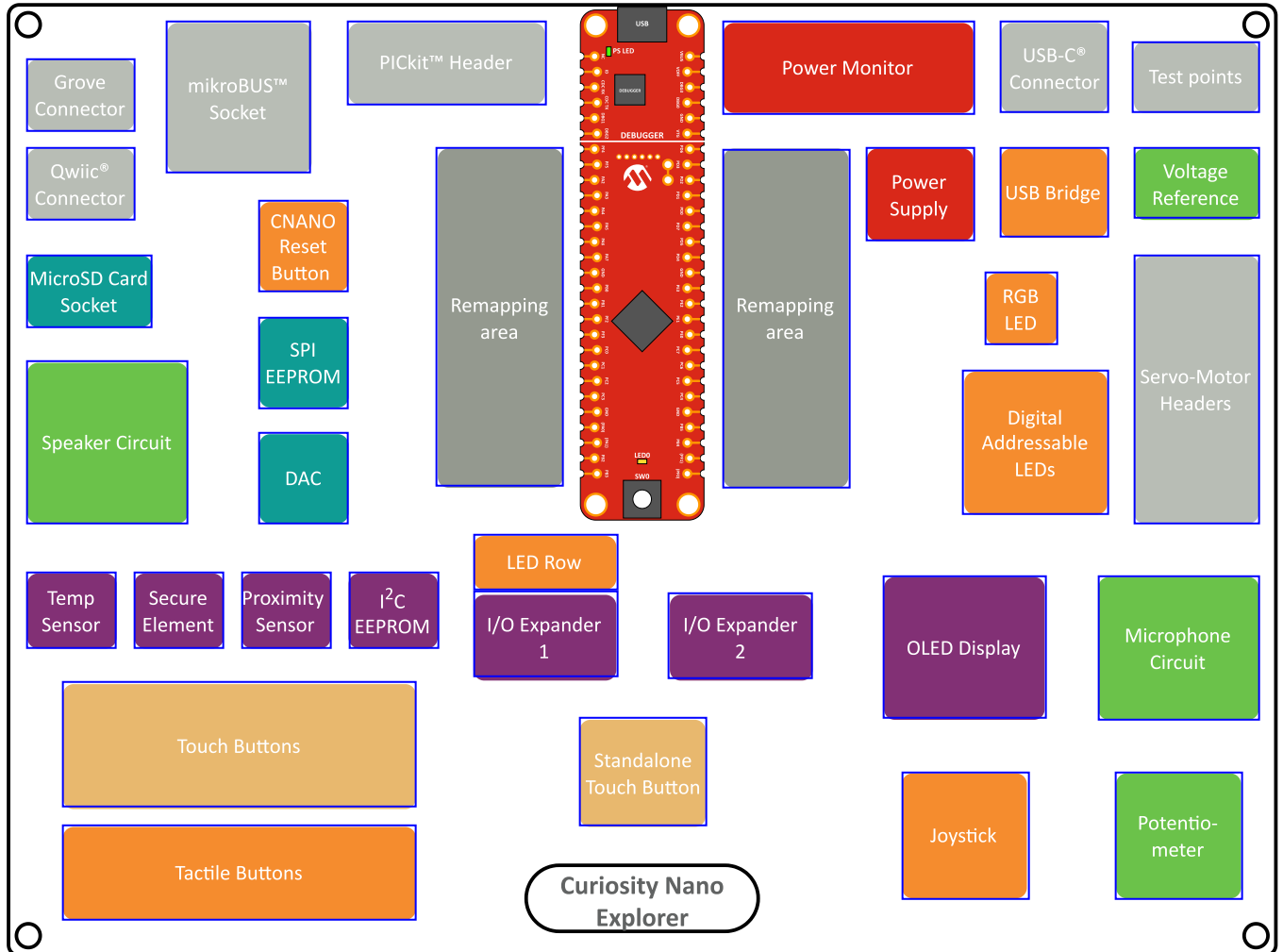

#### Tip:

- Swiftly navigate to your desired topic by clicking the corresponding block in the diagram above
- Click the  symbol in other block diagrams to return to the Explorer overview image

## 2.2. Board Image

Figure 2-2. Explorer Image

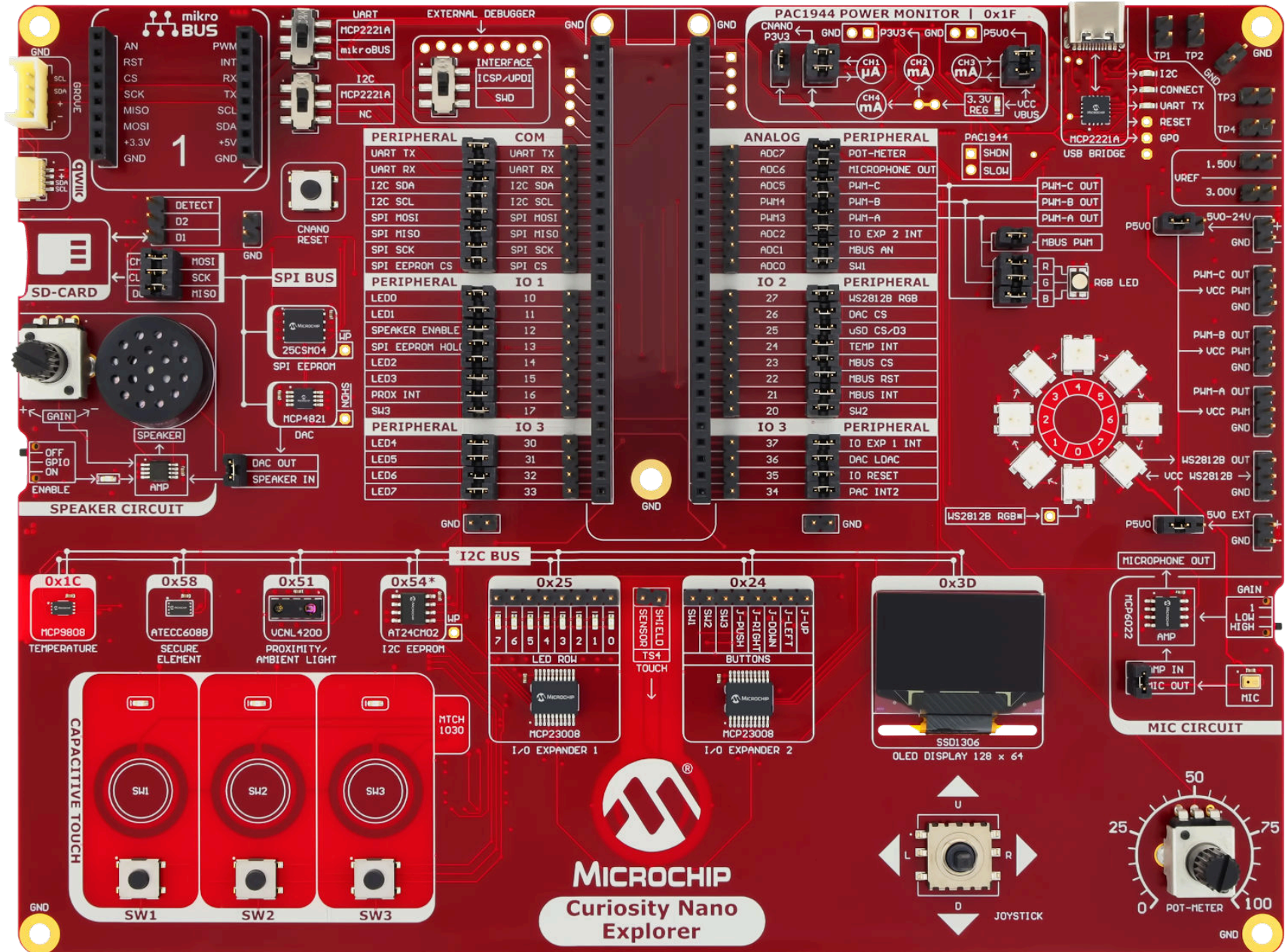

## 2.3. Feature List

- Curiosity Nano socket
  - Supports all Curiosity Nano development boards
  - Fully remappable pinout
- On-board peripherals
  - [MCP2221A](#) USB to UART/I<sup>2</sup>C-Bridge
  - [PAC1944](#) power monitor
  - [ATECC608B](#) secure element
  - [MCP4821](#) 12-bit digital-to-analog converter
  - [MTCH1030](#) touch controller
  - Two serial EEPROMs ([AT24CM02](#) and [25CSM04](#))
  - Two [MCP23008](#) I<sup>2</sup>C I/O-expanders
  - MicroSD card socket
- Multiple input options
  - [MCP9808](#) temperature sensor
  - Microphone and amplifier ([MCP6022](#)) with adjustable gain
  - Joystick
  - Potentiometer
  - Push buttons
  - Touch buttons
  - Proximity/ambient light sensor
- Multiple output options
  - LED row with eight yellow LEDs
  - OLED display
  - One RGB LED
  - Eight digital addressable LEDs
  - Three external PWM outputs for servomotors
  - Speaker and class-D amplifier with adjustable gain
- External connectivity options
  - Grove I<sup>2</sup>C connector
  - mikroBUS™ socket
  - Qwiic® I<sup>2</sup>C connector
- Multiple power sources
  - On-board USB Type-C® connector
  - USB powered from connected CNANO
  - External power options for addressable LEDs and servomotors
- On-board Power Supplies
  - [MIC33153](#) 4 MHz PWM 1.2A internal inductor buck switcher power module to power 3.3V peripherals
  - [MCP1754](#) 3.3V 150 mA LDO to power USB bridge and power monitor circuitry
  - [MIC2008](#) high-side power switch for slew rate control and over-current protection
- [MCP1501](#) user-remappable voltage references, 1.5V and 3.0V
- Reset button for connected CNANO MCU

### 3. Pinout and Remapping

Pinout and Remapping Area, Different Types of Remapping.

**Tip:** The mapping between Explorer and any Curiosity Nano development board can be found in the [Curiosity Nano Explorer Pinouts](#) document.

Figure 3-1. Pinout, Remapping Area and CNANO Socket

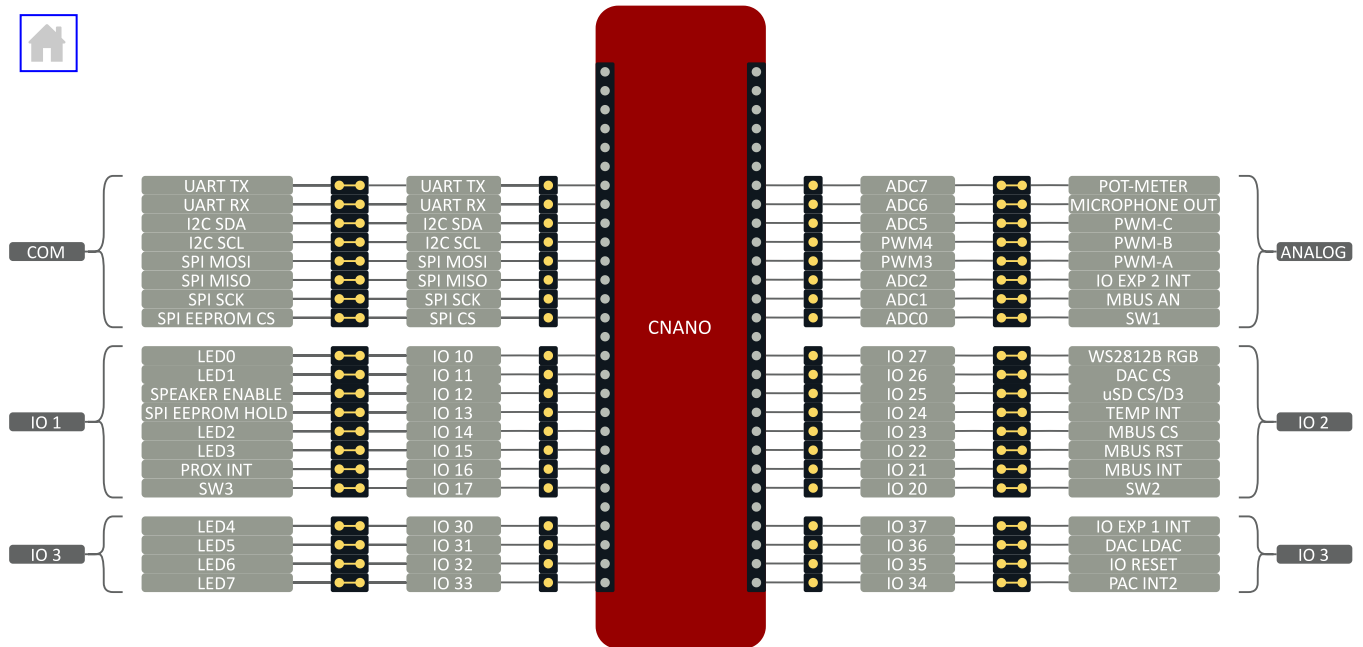

Connections to the CNANO socket are divided into five sections - COM, analog, IO1, IO2 and IO3. Standard functionality is assigned to each pin in the COM and analog section Curiosity Nano development boards. Pins in the I/O sections are numbered with a <section><pin-number> format, ex: "IO 26" indicates section 2 pin 6.

**Info:** Curiosity Nano development boards with low pin count microcontrollers may not implement the standard functionality in the COM and analog sections.

Figure 3-2. Explorer to CNANO Connections

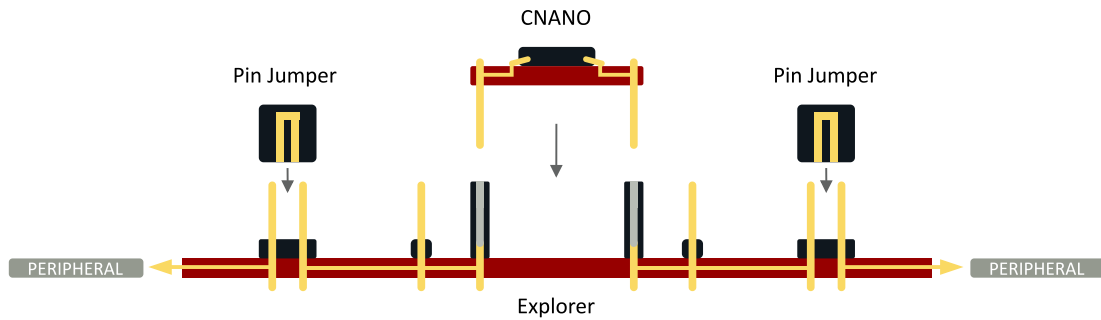

**Tip:** Connect your measuring tool to the innermost pin header for easy access to any signal on the Explorer. Use the [custom test points](#) for access with longer measurement probes.

### 3.1. CNANO Socket Remapping

The Explorer's connections to the CNANO socket are fully remappable. Any peripheral can be connected to any pin on the socket.

Figure 3-3. Peripheral to CNANO Pin Remapping

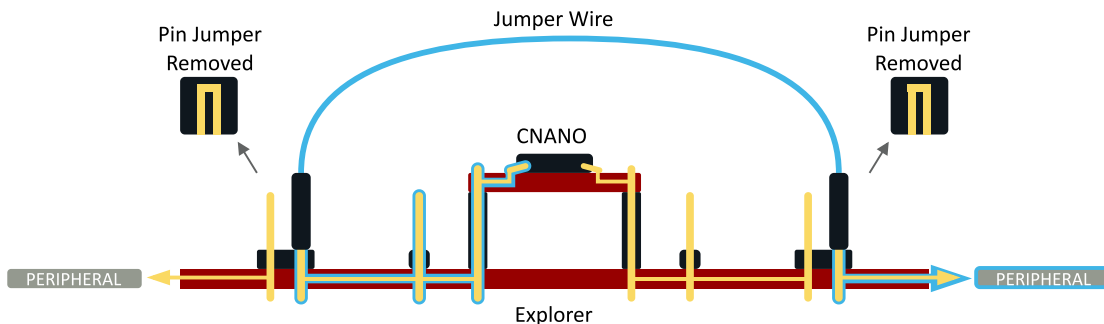

**Tip:** Peripheral connections are labeled on the silkscreen.

### 3.2. Direct Remapping

Many peripherals on the Explorer can be remapped by connecting a pin directly to the CNANO socket using a jumper wire. For example, if your CNANO's microcontroller has a DAC (Digital-to-Analog Converter) output, you can directly connect it to the speaker amplifier.

Figure 3-4. Direct peripheral remapping

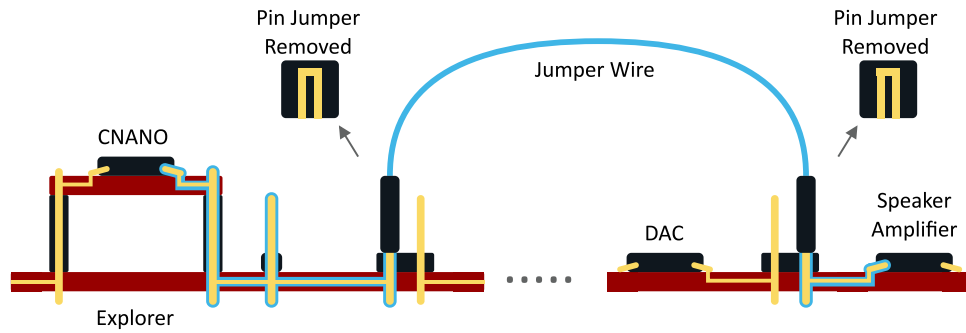

### 3.3. Custom Test Points

The Explorer features four customizable test points available on the board edge. The test points are labeled TP1, TP2, TP3 and TP4 on the silkscreen.

Easily measure any signal by connecting a jumper wire between the innermost pin header in the remapping area and a test point.

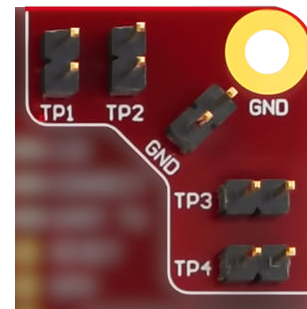
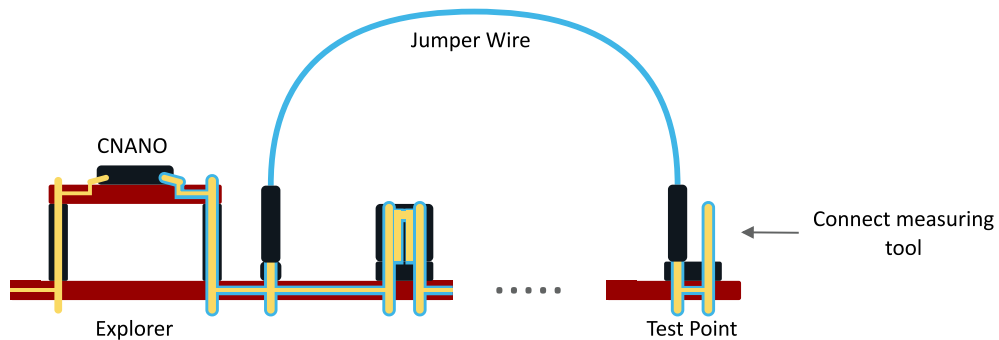

Figure 3-5. Connecting Net to Test Point



**Tip:** A pin header with ground connections is available next to the test points.

## 4. Power Supply and Monitor

Power supply, Power Monitor.

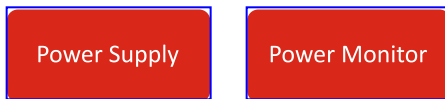

### 4.1. Power Supply

Figure 4-1. Power Supply Overview

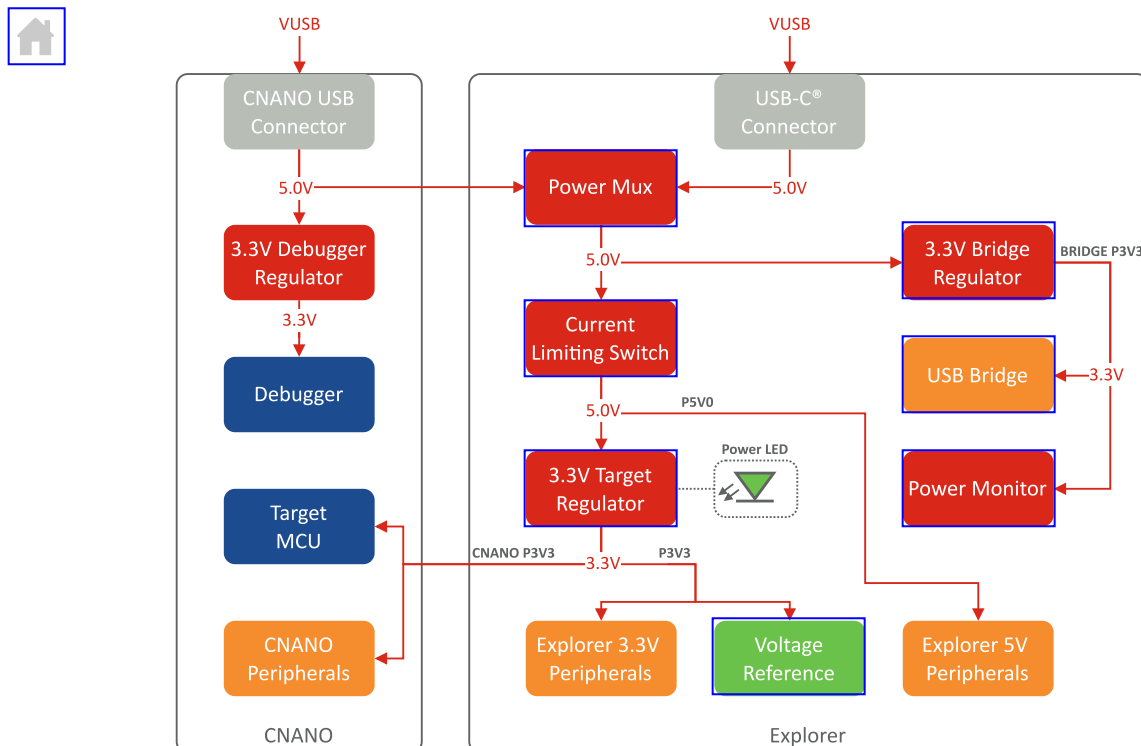

**➔ Important:** The Explorer powers the CNANO at 3.3V, and all the pins connected to the CNANO socket are designed for use with 3.3V I/O pins.

The Explorer's power supply features:

- Dedicated 3.3V regulator to power the CNANO and 3.3V peripherals
  - The CNANO's **target regulator is disabled** while connected to the Explorer
- 5V peripherals powered directly by USB voltage
- A power multiplexer allows power supplied from the on-board USB-C<sup>®</sup> connector or the CNANO
- A current limiting switch with a soft start to protect the board, the current limit set at 2A
- On-board power monitoring for voltage and current measurement with four channels

**Table 4-1. Power Domain Specifications**

Power Domain	Vnom	Vmin - Vmax	I <sub>max</sub>
P5V0	5.0V	4.4–5.5V	2.0A
P3V3	3.30V	3.22–3.38V	1.2A
CNANO P3V3	3.30V	3.22–3.38V	1.2A
BRIDGE P3V3	3.30V	3.23–3.37V	150 mA

#### 4.1.1. Power Sources

The two main power sources are:

- The USB connector on the CNANO
- The USB-C<sup>®</sup> connector on the Explorer

Current limitations:

- The CNANO's VBUS output has a current limitation of 500 mA
- The Explorer's USB-C<sup>®</sup> connector can sink different amounts of current based on the USB source (up to 3.0A from a USB-C<sup>®</sup> source)
- Both USB inputs are fed into a power multiplexer, with output current limited to 2.0A

**Info:** If both USB connectors are powered, the current is sourced through the Explorer's USB-C<sup>®</sup> connector.

**Figure 4-2. Power MUX Overview**

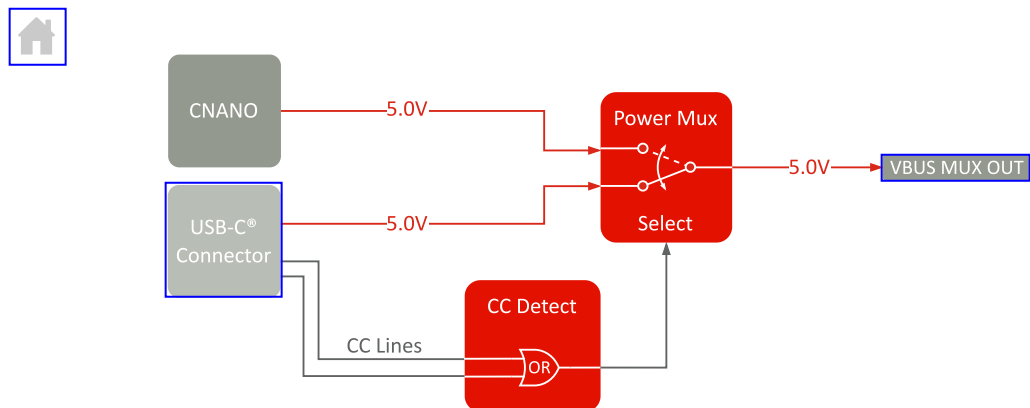

#### 4.1.2. Power Domains

There are four main power domains on the Explorer:

- P5V0
- P3V3
- CNANO P3V3
- BRIDGE P3V3

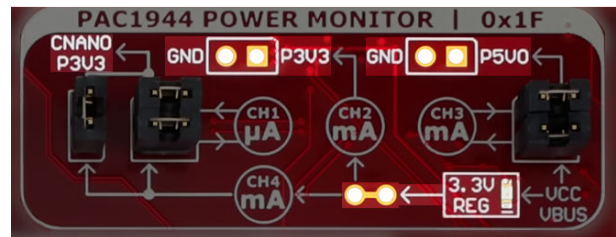

CNANO P3V3 is powered by the same regulator as P3V3, separated for dedicated power measurement of the CNANO. It powers the CNANO's external power input. Refer to [CNANO Power Configuration](#) for more information.

**Table 4-2.** Peripherals Connected to the Different Power Domains

Power Domain	Power Measurement Channel	Peripheral
CNANO P3V3	CH1 (uA), CH4 (mA)	Connected CNANO
P3V3	CH2 (mA)	Touch controller
		I/O expander 2 + button LEDs
		I/O expander 1 + LED row
		I <sup>2</sup> C EEPROM
		Secure Element
		Proximity and ambient light sensor (digital circuitry)
		Temperature sensor
		OLED display
		SPI EEPROM
		DAC
		Voltage reference
		Microphone circuit
		Speaker circuit
		Potentiometer
		mikroBUS™ socket (3.3V pin)
MicroSD card socket		
Grove and Qwiic® connector		
P5V0	CH3 (mA)	RGB LED
		Digital addressable LEDs
		Servomotor circuit
		Proximity and ambient light sensor (internal LED)
		mikroBUS™ socket (5V pin)
BRIDGE P3V3	-	Power monitor circuit
		USB bridge circuit

**Figure 4-3.** Power Domains Overview

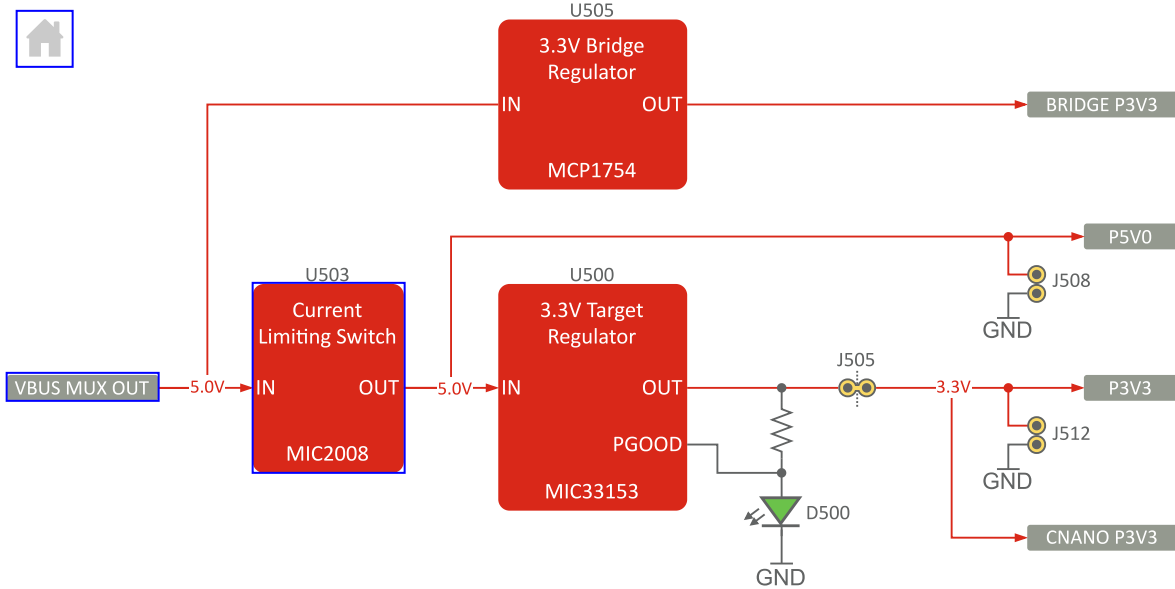

### 4.1.3. Current Limiting Switch

A [MIC2008](#) current limiting switch with an adjustable slew rate is mounted on the board to prevent large inrush currents. The switch has been configured with a current limit of 2.0A by selecting resistor R500 to be 120Ω.

**Info:** MIC2008 current limit range: 0.2–2.0A. See the [MIC2008 data sheet](#) for more information

Figure 4-4. Current Limiting Switch

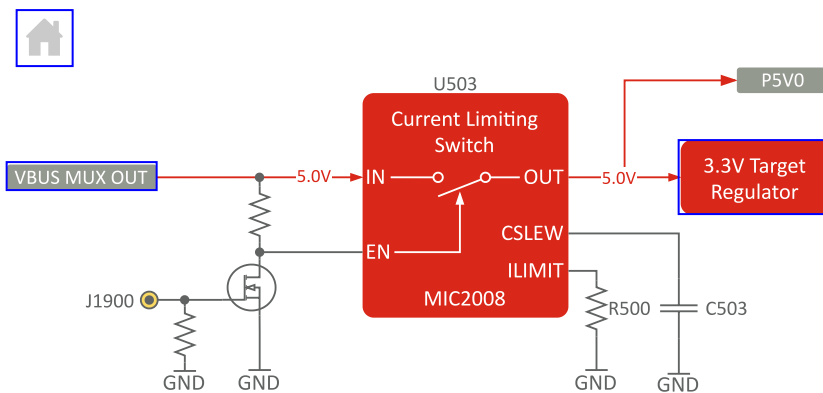

### 4.1.4. CNANO Power Configuration

The Explorer supplies the CNANO with a fixed 3.3V. When connected to the Explorer, the on-board regulator of the CNANO is disabled by pulling the VOFF pin low, ensuring no logic level mismatches between the CNANO and the Explorer.

**Info:** The CNANO's on-board debugger is only powered when the CNANO USB is connected to power.

**➔ Important:** When connected to the Explorer, the adjustable target voltage feature of the CNANO is disabled.

**Figure 4-5.** Power Configuration of the Connected CNANO

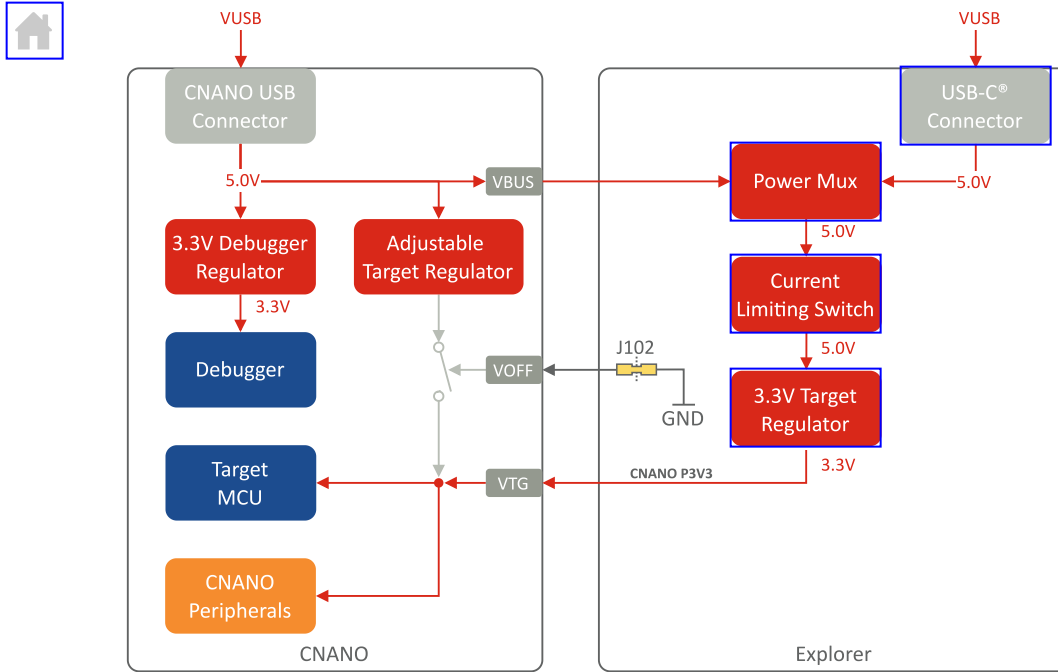

## 4.2. Power Monitor

### 4.2.1. Getting Started with Power Monitor

The on-board PAC1944 quad-channel power monitor circuit allows tracking of the power consumption of peripherals on the Explorer. The measurement data can be accessed through the USB bridge MCP2221A.

To read and visualize power data, download and install the PAC194x/PAC195x Demo Application.

Figure 4-6. PAC194x/PAC195x Demo Application

The screenshot displays the PAC194x/PAC195x Demo Application window. At the top, there are menu options (Settings, Help) and a toolbar with buttons for 'Start Acquisition', 'Log to file', 'Open Last Log', 'Show Plots', and 'Refresh'. The 'Show Plots' button is highlighted with a red box and the number 3. Below the toolbar, there are tabs for 'Demo', 'Configuration', 'Alerts Config', and 'I2C Script'. The main area is divided into several sections: 'PRODUCT ID' (PAC1944), 'DEMO SETTINGS' (with 'AVG register Value' selected), 'GPIO Status', 'CHANNEL ALERTS' (a table with columns for Over Current, Under Current, Over Voltage, Under Voltage, and Over Power), 'DEVICE ALERTS' (with 'Any Alert' checked), and 'SLOW PIN TRANSITIONS'. The 'REAL DATA' section shows four columns for channels CH1, CH2, CH3, and CH4, each with a table of metrics like Vbus (V), Vsense (mV), Current (mA), Power (W), Accumulator (W), Energy (uWh), and Count. The 'Sense resistor (mOhm)' field for CH1 is highlighted with a red box and the number 1, showing a value of 51000. The 'Start Acquisition' button is highlighted with a red box and the number 2.

Open the application and perform the following steps to get started:

1. Configure the sense resistor value:
  - a. Channel 1: 51000
  - b. Channel 2: 75
  - c. Channel 3: 50
  - d. Channel 4: 220
2. Start Acquisition.
3. Press "Show Plots" to visualize the data.

**➔ Important:** While using the demo application set the I<sup>2</sup>C slide switch to the "NC" position, which isolates the PAC1944 and MCP2221A from the rest of the Explorer's I<sup>2</sup>C bus.

## 4.2.2. Power Measurement Channels

The four PAC1944 measurement channels measure three of the four main power domains on the Explorer:

- P5V0 (CH3)
- P3V3 (CH2)
- CNANO P3V3 (CH1 and CH4)

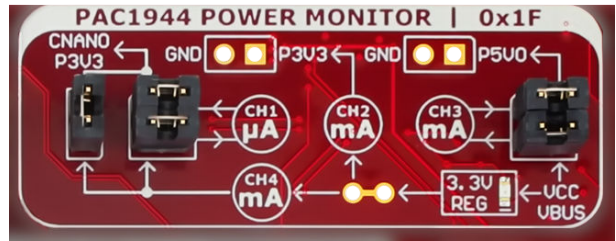

Figure 4-7. Measurement Channels

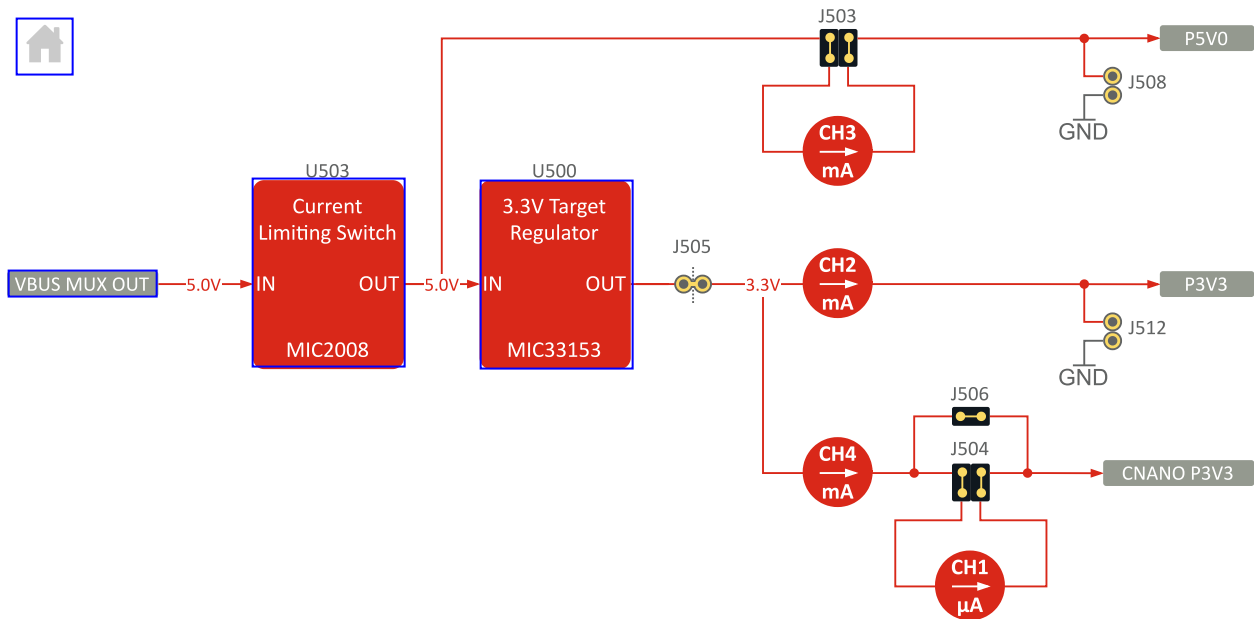

Table 4-3. Measurement Channel Specifications

Default Power Domain	Channel	Current Sense Range	Current Sense Resolution	Sense Resistor
P5V0 (mA)	CH3	$\leq 2.00\text{A}$	$30.5\ \mu\text{A}$	$0.050\Omega$
P3V3 (mA)	CH2	$\leq 1.33\text{A}$	$20.3\ \mu\text{A}$	$0.075\Omega$
CNANO P3V3 (mA)	CH4	$\leq 455\ \text{mA}$	$6.94\ \mu\text{A}$	$0.220\Omega$
CNANO P3V3 ( $\mu\text{A}$ )	CH1	$\leq 1.96\ \text{mA}$	$29.9\ \text{nA}$	$51.0\Omega$



**Tip:** To identify which peripherals are powered by each power domain, see [Table 4-2](#).

### Measure CNANO P3V3 Power

CH1 and CH4 measure current to the CNANO P3V3 power domain.

- CH1 for  $\mu\text{A}$  measurements
- CH4 for mA measurements

The user can change which channel is in use by placing or removing the pin jumper on pin header J506.

**➔ Important:** The sense resistor for CH1 is 51Ω. Currents above 2 mA will cause a significant voltage drop in the voltage supplied to the attached CNANO.

**Figure 4-8.** Currents Above 2 mA (CH1 bypassed)

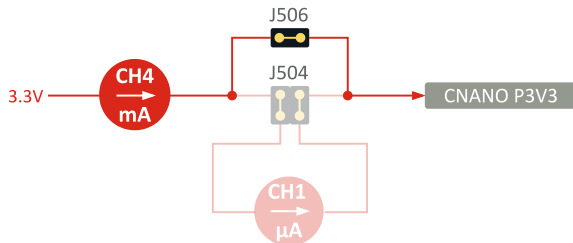

**Figure 4-9.** Currents Below 2 mA (CH1 connected)

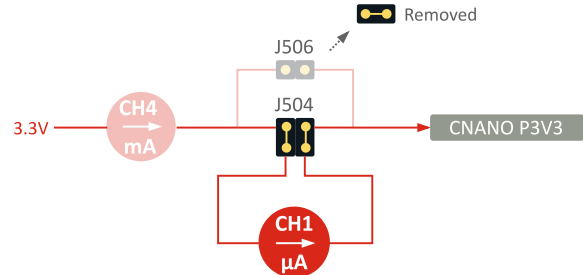

### Measure External Power

CH1 and CH3 can be disconnected from their default connections to measure current from external sources.



**WARNING**

Remember to connect the GND from the Explorer to the GND of the external source. Do not apply voltages above 9V to the current measurement channels.

**Figure 4-10.** Connect External Source to CH1 (μA)

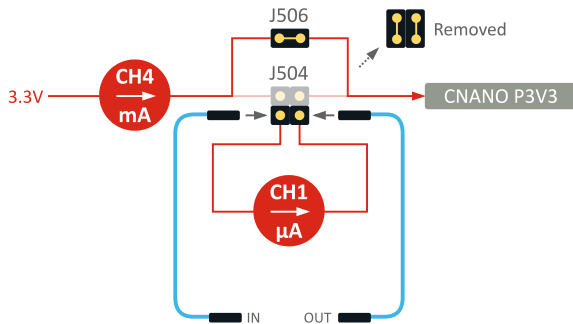

**Figure 4-11.** Connect External Source to CH3 (mA)

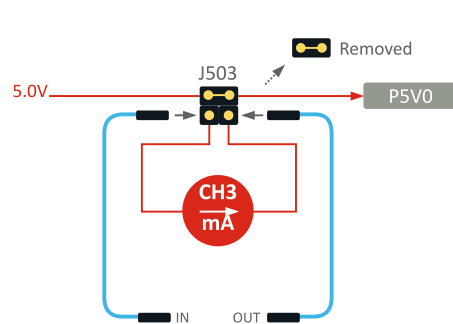

### 4.2.3. Quad Channel Precision Power Monitor

Feature overview:

- High-side current monitor with four channels
- 100 mV full-scale range
- 0-9V full-scale range
- 16-bit resolution
- On-chip accumulation of 30-bit power results from energy measurement

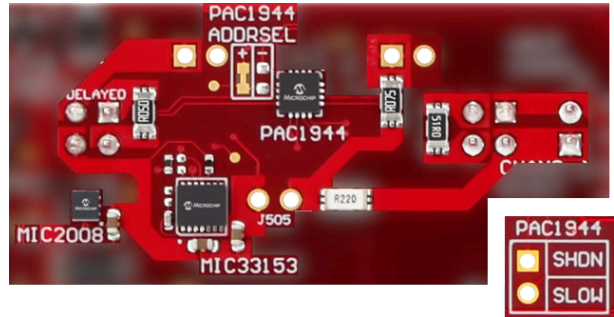

The PAC1944 may also be accessed by the microcontroller on the CNANO using the I<sup>2</sup>C bus.

**➔ Important:** Set the I<sup>2</sup>C slide switch to the "MCP2221A" position to connect the PAC1944 and MCP2221A to the rest of the I<sup>2</sup>C bus on the board.

Figure 4-12. Power Monitor Overview

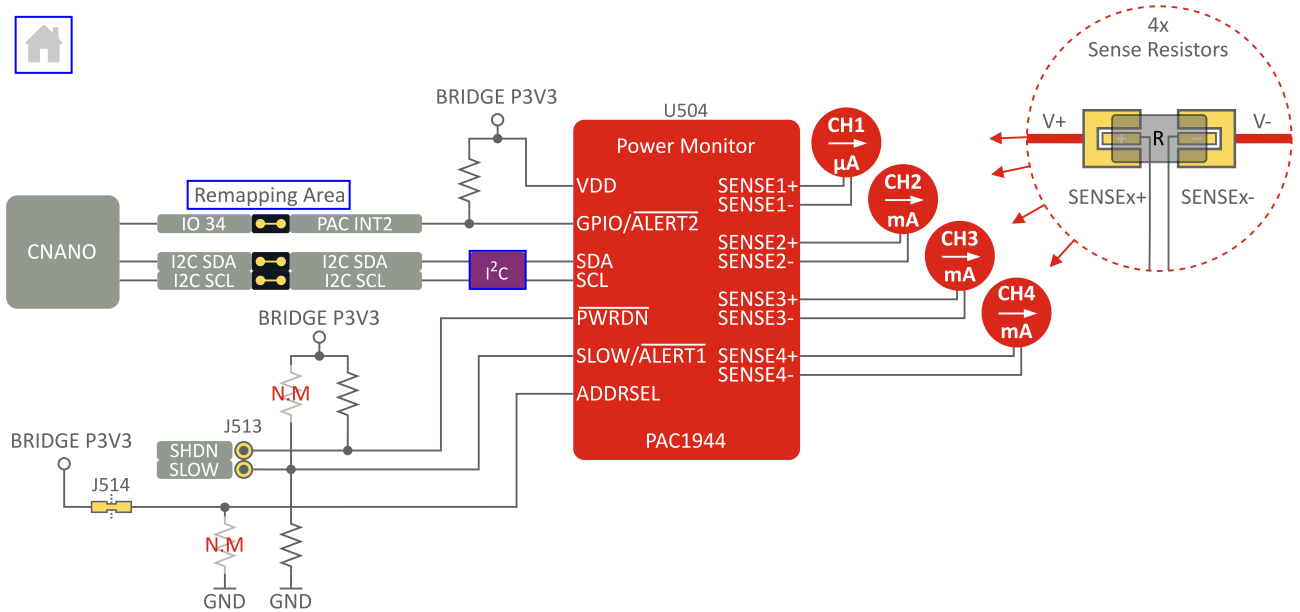

## 5. Buttons and LEDs

Digital Addressable LEDs, RGB LED, LED Row and I/O Expander 1, Buttons, Joystick and I/O Expander 2, Touch Controller

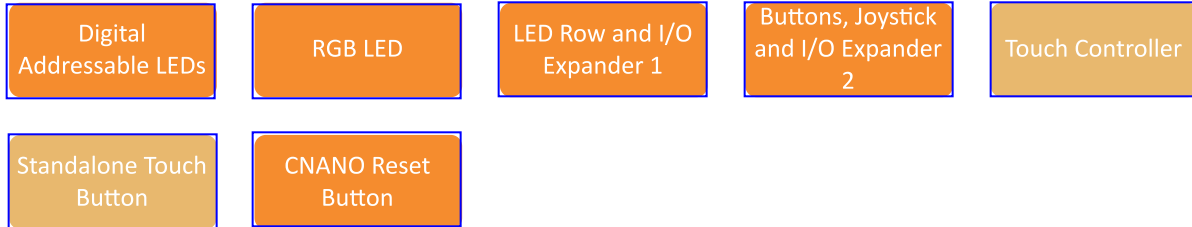

### 5.1. Digital Addressable LEDs

The Explorer features eight serially addressable RGB LEDs. These LEDs behave similarly to WS2812B LEDs. Comparator U301 (MCP6561) connects the control signal from the CNANO socket and acts as a logic-level translator.

- Select the power source using the J316 pin header
- Supply external power through the J302 pin header
- The LED strip is extendable using the J303 pin header

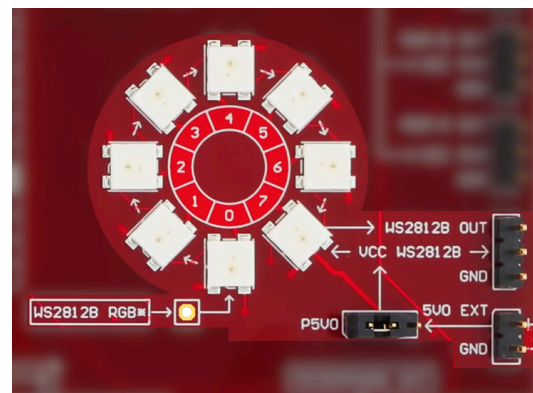

**Tip:** The LED strip input is available through the pin header footprint J313.

Figure 5-1. Addressable LED Circuit

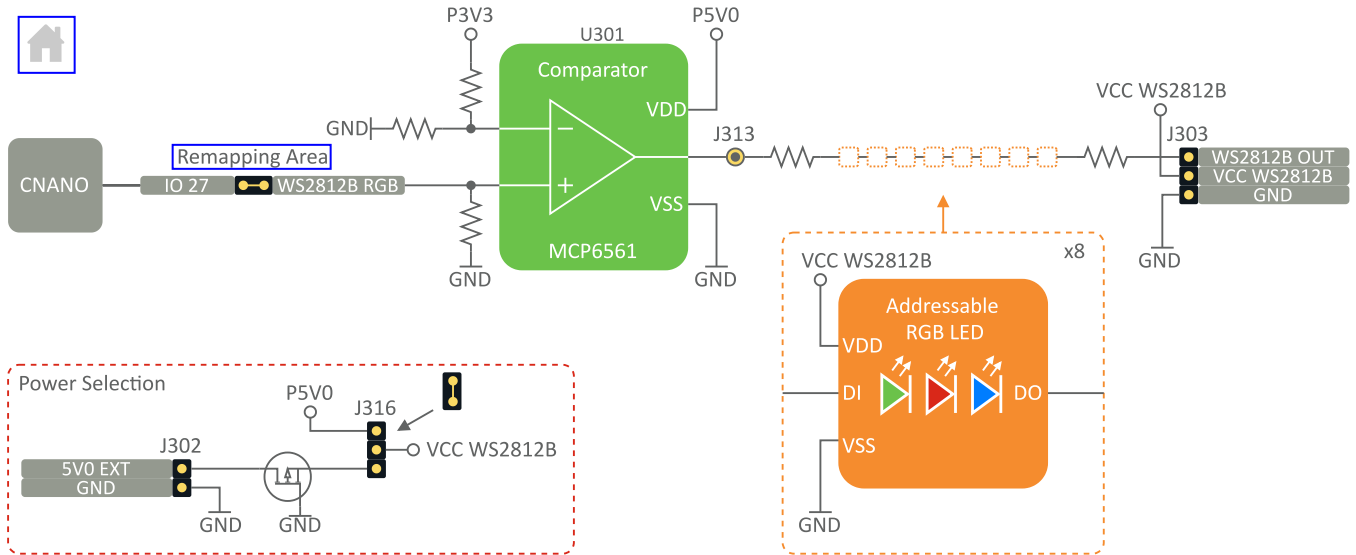

**➔ Important:** Long LED strips consume a lot of current, and it is recommended to use an external supply to power LED strips attached to the board.

**💡 Tip:** Check out the PIC<sup>®</sup> and AVR<sup>®</sup> examples for driving WS2812 or similar LEDs on MPLAB<sup>®</sup> Discover.

Related information: [Addressable LEDs Timing and Format](#).

## 5.2. RGB LED

An RGB LED is connected to the PWM outputs from the CNANO socket.

**⚠ CAUTION** The LED is very bright when driven at full power – do not stare at it.

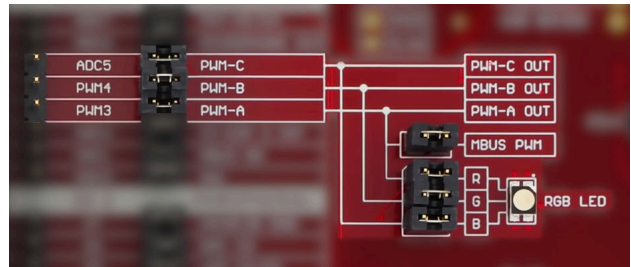

The PWM outputs from the CNANO socket are shared between the servomotor driver and the mikroBUS<sup>™</sup> socket. Disconnect the different channels by removing the jumper caps from J203 and J309.

- Pin header J309 connects the RGB LED to the CNANO socket
- Pin header J203 connects the mikroBUS<sup>™</sup> PWM channel to the CNANO socket

**Figure 5-2.** RGB LED Overview

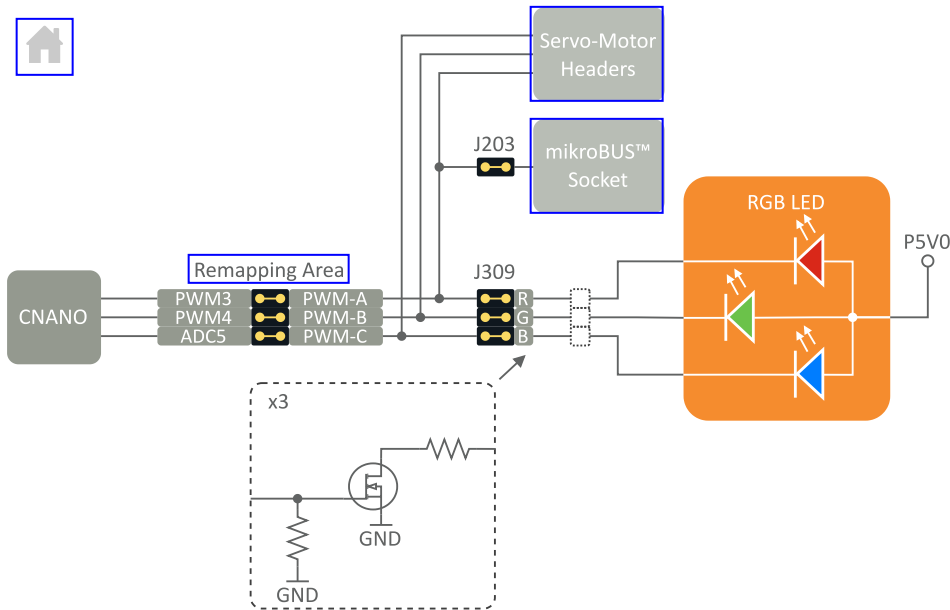

 **Tip:** Check out the PIC and AVR examples for driving RGB LEDs on [MPLAB® Discover](#).

### 5.3. LED Row and I/O Expander 1

#### LED Row

The Explorer features eight controllable yellow LEDs. Turn the LED on by pulling the pin low (active-low).

The eight LEDs can be controlled in three different ways:

1. From the Remapping Area.
2. From I/O Expander 1 via the I<sup>2</sup>C Bus.
3. From the 1x8 pin header (J301).

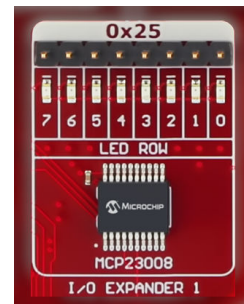

#### I/O Expander 1

Set the GP pin to output-low mode on the I/O Expander to activate (turn on) the LED.

 **Info:** Each LED is connected to a resistor network, ensuring that no short circuits occur if controlled from multiple sides simultaneously.

Figure 5-3. LED Row Connections



**Info:** I/O Expander 1's 7-bit I<sup>2</sup>C address: 0x25. The I<sup>2</sup>C address can be changed using pins A0-A2 and follows the address format '0100, A2, A1, A0'.

## 5.4. Buttons, Joystick and I/O Expander 2

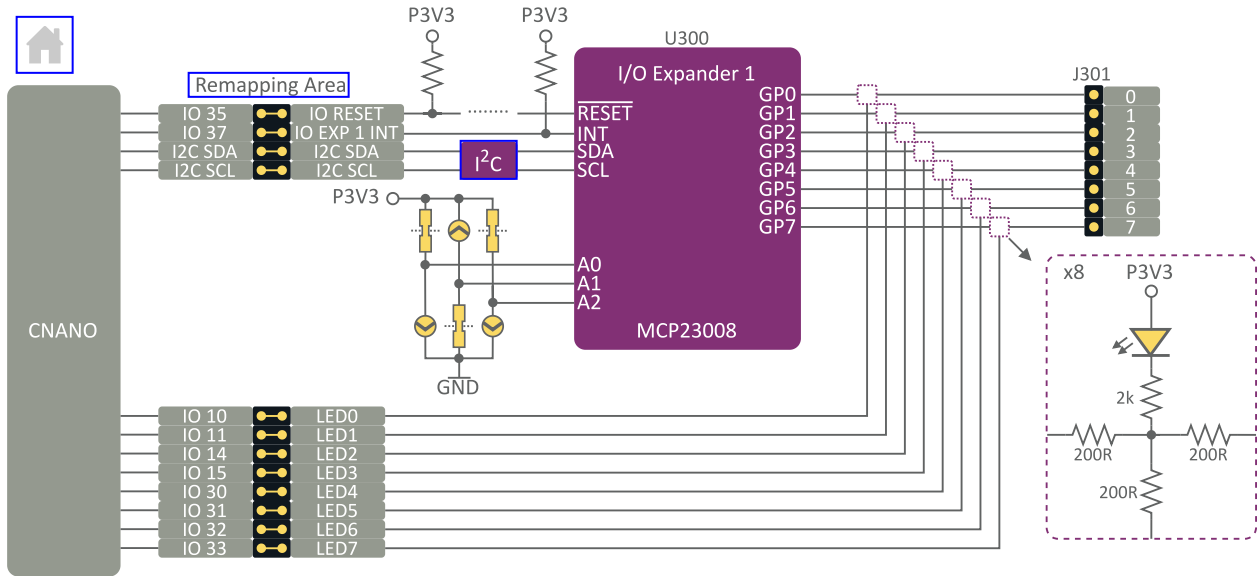
### Tactile and Touch Buttons

Three tactile and three touch buttons are available as user inputs on the Explorer. The buttons are connected in a group of one LED, one tactile, and one touch button. The grouping is shown on the silkscreen. Pressing any button in the same group will assert the same signal and activate the LED.

The button signals can be accessed in three different ways:

1. From the Remapping Area.
2. From I/O Expander 2 via the I<sup>2</sup>C Bus.
3. From the 1x8 pin header (J401).



**Tip:** See section [Touch Controller](#) for more information on the touch buttons.

## Joystick

The joystick signals can be accessed in two different ways:

1. From I/O Expander 2 via the I<sup>2</sup>C Bus.
2. From the 1x8 pin header (J401).

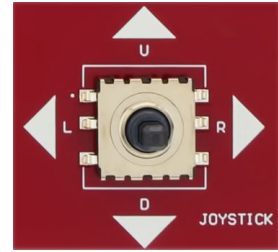

## I/O Expander 2

Configure the GP pins as inputs with internal pull-ups to read the button states with the I/O Expander.

---

**i Info:** Each button signal is connected to a resistor network, ensuring there are no short circuit occurs if a pin is set high while the button is pressed.

---

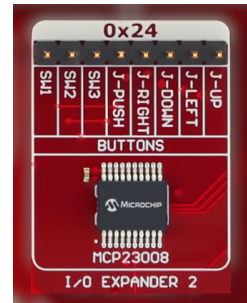
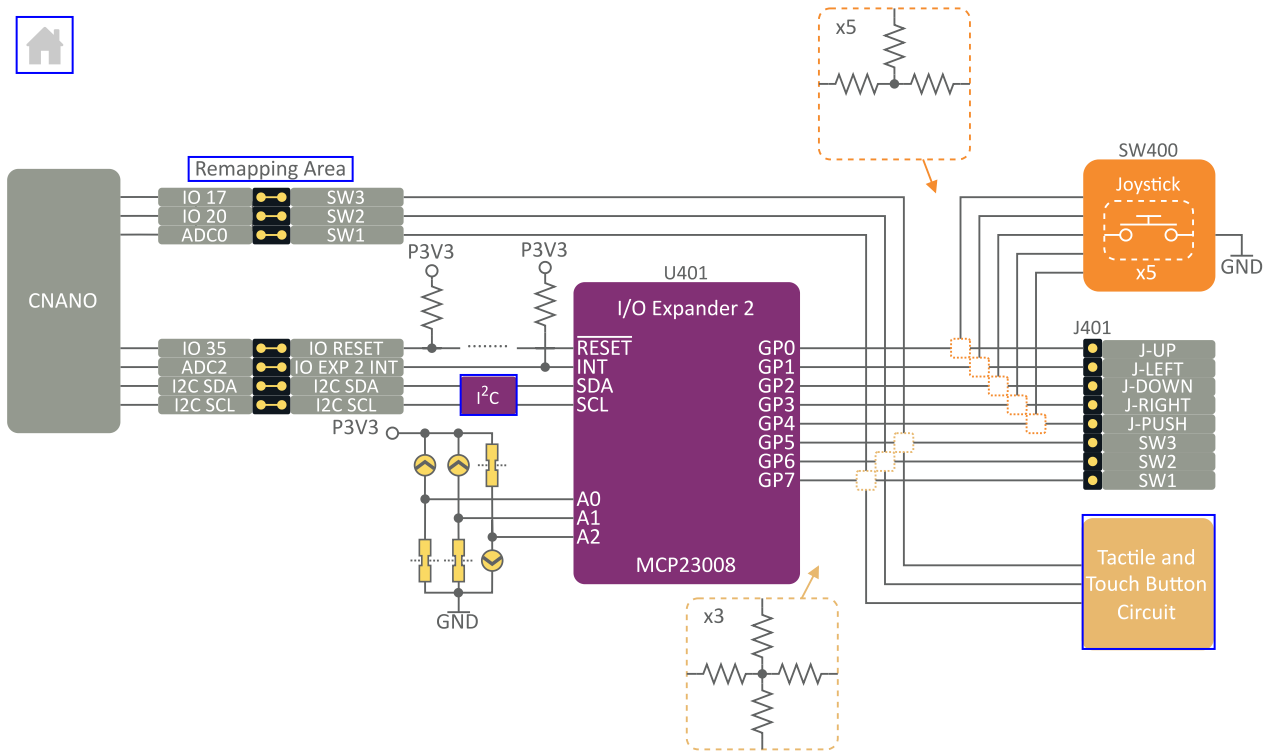

Figure 5-4. Buttons and Joystick Connections



**Info:** I/O Expander 2's 7-bit I<sup>2</sup>C address: 0x24. The I<sup>2</sup>C address can be changed using pins A0-A2 and follows the address format '0100, A2, A1, A0'.

## 5.5. Touch Controller

The three touch buttons are connected to the [MTCH1030](#) touch controller. The touch buttons are sensed using capacitive touch sensors with active shields utilizing the Driven Shield Plus feature. Response time, oversampling, touch sensitivity, easy tune, and single-button mode are configured through resistors networks on the bottom side of the Explorer. The parameters are read by the touch controller during power-up and only the single-button mode can be altered at run-time.

**Info:** OUTx pin indicates the touch detection state of BUTTONx. The pin idles in a high-impedance state. When the touch button is pressed, it switches to output-low.

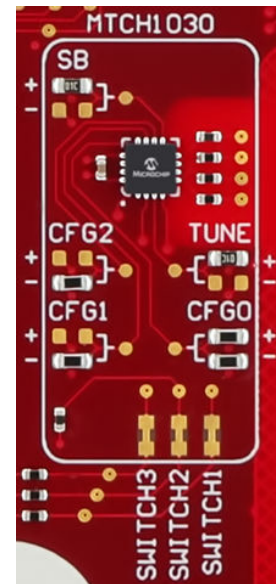
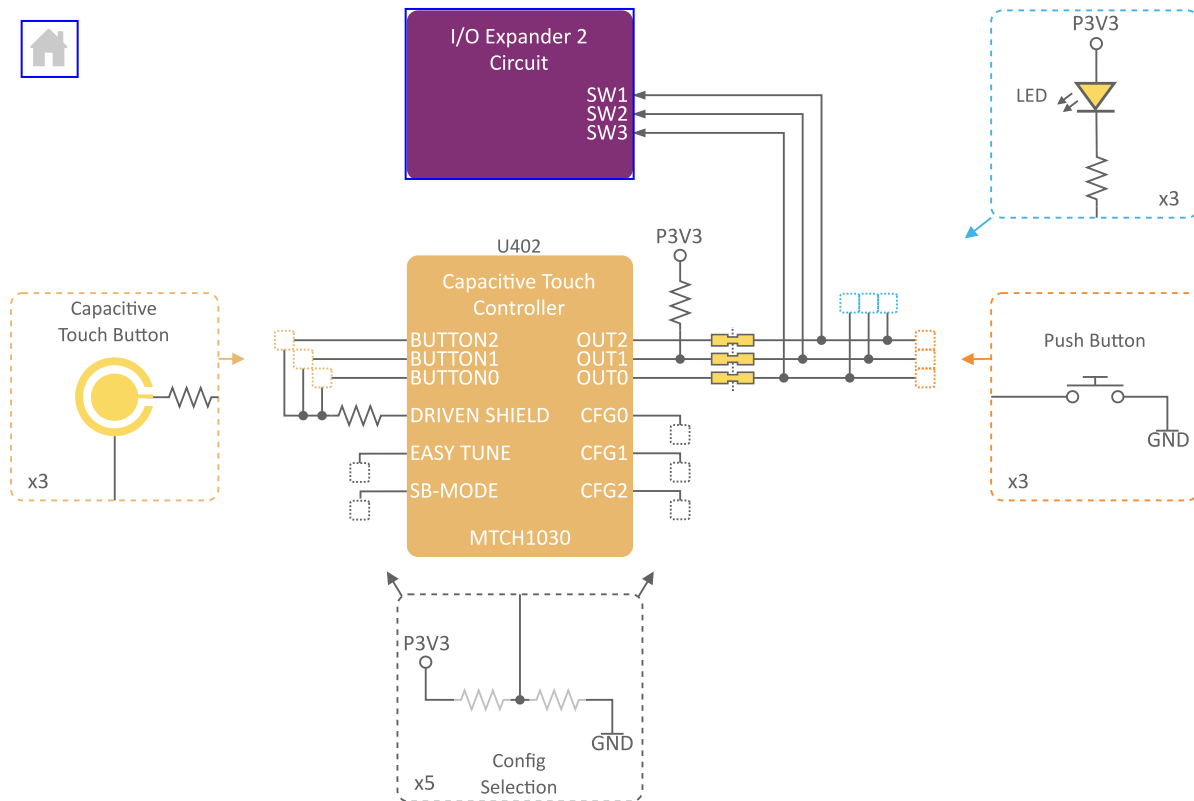

Figure 5-5. MTCH1030 Connections



**Info:** By default, the Touch Tune Data feature of MTCH1030 is disabled due to the pull-up resistor on pin OUT1. To use this feature, refer to the chapter [MTCH1030 Touch Tune Data](#) in the appendix.

**Info:** The MTCH1030 enables anti-touch recalibration if a touch button pressed for more than 8s. This causes the OUTx pin to revert to a high-impedance state.

The MTCH1030 touch controller on the Explorer is configured as follows:

- Measurement Period: Back-to-back measurements (minimum period)
- Oversampling: Eight samples per measurement cycle
- Sensitivity: 0-63
- Easy Tune: Disabled
- Single-Button Mode: Disabled

**Tip:** Touch sensor data captured with MTCH1030 can be visualized using the [MPLAB® Data Visualizer](#), see section [MTCH1030 Touch Tune Data](#).

## 5.6. Standalone Touch Button

Underneath the Microchip logo is a single standalone capacitive touch button with an optional active shield.

If the microcontroller on the CNANO supports capacitive touch sensing, the standalone capacitive touch button can be used by connecting it to the remapping area from the 1x2 pin header J404. See section [Direct Remapping](#).

The sensor and shield pins are labeled in the silkscreen next to the pin header.

**Figure 5-6.** Standalone Touch Button

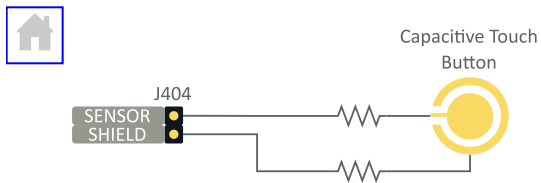

**Tip:** Generate code with the capacitive touch library in [MCC Melody](#) and visualize touch sensor data in [MPLAB® Data Visualizer](#).

## 5.7. CNANO Reset Button

The Explorer features a reset button connected to the default reset pin location of the CNANO. The CNANO microcontroller (MCU) must have the reset functionality enabled for this button to work. Refer to your MCU's data sheet to determine the pin location and function, and consult the CNANO schematics to see how it is connected.

**Important:** The reset button will reset only the CNANO MCU. Pressing the button will not reset the peripherals on the Explorer.

**Figure 5-7.** CNANO Reset Button

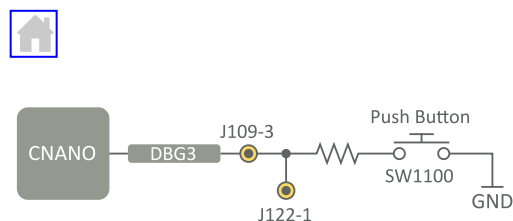

## 6. Serial Communication

USB Bridge, UART, I<sup>2</sup>C and SPI Peripherals.



### 6.1. USB Bridge

The [MCP2221A](#) is a USB-to-UART/I<sup>2</sup>C serial converter. It bridges the gap between a computer's USB port and the I<sup>2</sup>C and UART interfaces on the Explorer.

When the on-board USB-C<sup>®</sup> is disconnected, the USB bridge is held in reset. You can keep the USB bridge in reset using the MCU on the CNANO by pulling IO-37 on the Explorer low.

**Tip:** When not in use, it is recommended to disconnect the bridge reset from the CNANO socket by removing the jumper cap on IO-37.

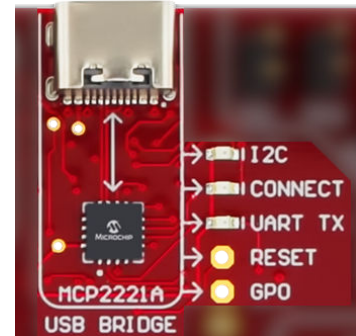
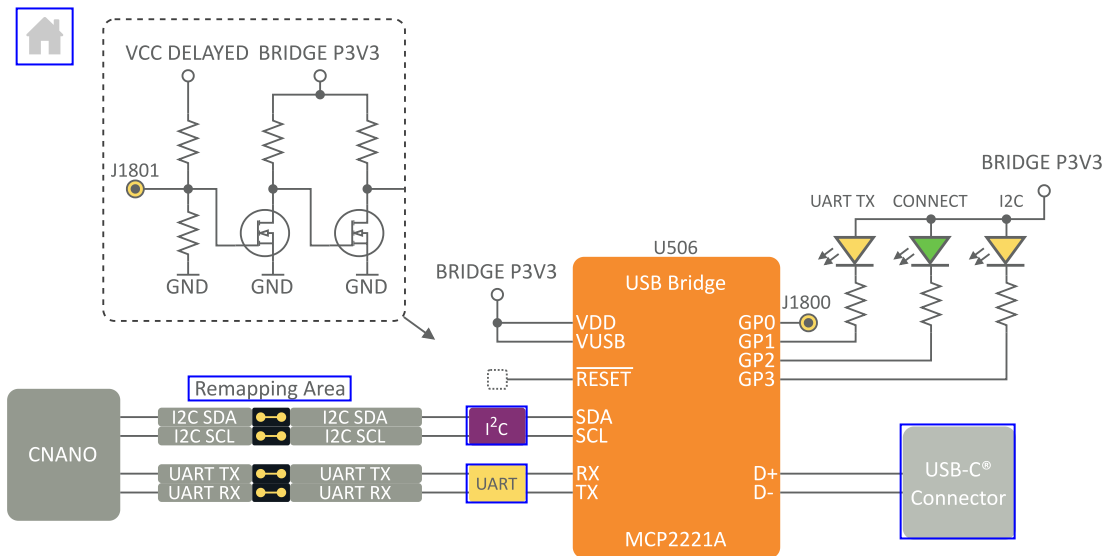

Figure 6-1. USB Bridge Overview



**Tip:** Drivers, CLI tools and apps are available to interface with the [MCP2221A](#) on its web page.

The USB bridge can be disconnected from the main I<sup>2</sup>C bus on the Explorer using slide switch S500. When disconnected, the USB bridge and the power monitor IC are isolated on their own I<sup>2</sup>C bus.

**➔ Important:** The USB bridge is only able to act as an I<sup>2</sup>C host.

The UART connection to the CNANO socket is shared between the USB bridge and the mikroBUS™ socket. Use slide switch S501 to select the connected UART.

## 6.2. UART Peripherals

The CNANO's default UART pins are shared between the USB bridge and the mikroBUS™ socket. Only one of the connections is active at any time. Select which pins are connected to the CNANO socket using slide switch S501.



Figure 6-2. UART Overview

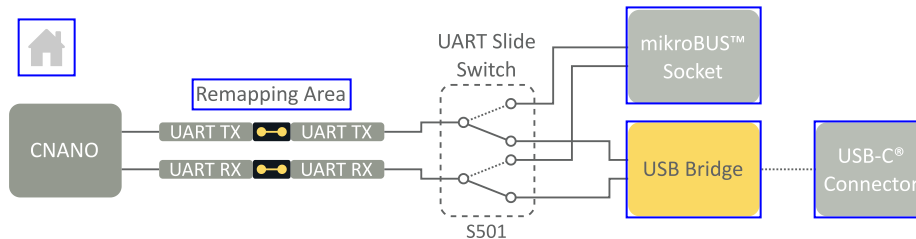

## 6.3. I<sup>2</sup>C Peripherals

### 6.3.1. I<sup>2</sup>C Bus

Figure 6-3. I<sup>2</sup>C Bus Overview

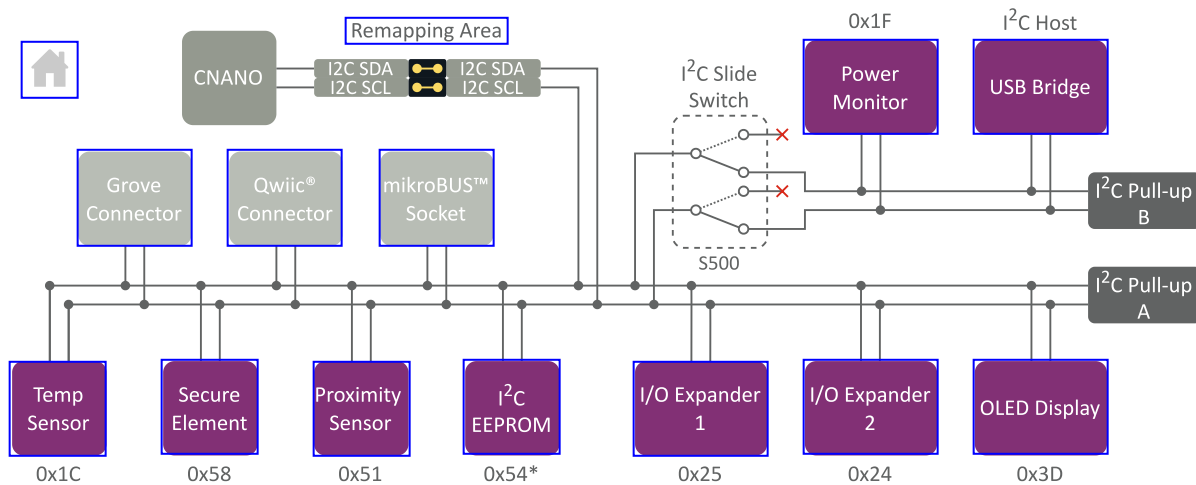

The Explorer features an I<sup>2</sup>C bus with several attached devices and external connectivity options. All connected devices are compatible with Standard Mode (100 kHz) and Fast Mode (400 kHz) I<sup>2</sup>C. The

bus is designed to meet the rise-time requirements for both modes. The SDA and SCL signals are connected to the COM section of the CNANO socket.

**➔ Important:** Connecting I<sup>2</sup>C extension boards with pull-ups will impact bus performance.

The Explorer's I<sup>2</sup>C bus can be split into two separate buses using the slide switch S500. Each bus has its own set of pull-ups - I<sup>2</sup>C pull-ups A and B.

When the I<sup>2</sup>C bus is split, the USB bridge and the power monitor ICs are isolated from the main I<sup>2</sup>C bus, with the USB bridge acting as the host to communicate with the power monitor IC.

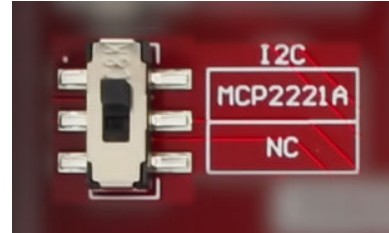

**➔ Important:** The USB bridge can function only as an I<sup>2</sup>C host.

**Table 6-1.** I<sup>2</sup>C Electrical Characteristics

Parameter	Value
I <sup>2</sup> C Pull-up A	2.7 kΩ
I <sup>2</sup> C Pull-up B	5.1 kΩ
<b>I<sup>2</sup>C bus with Pull-ups A and B</b>	
I <sup>2</sup> C bus capacitance <sup>1</sup>	130 pF
Rise-time <sup>2</sup>	~200 ns
<b>I<sup>2</sup>C bus with Pull-up A isolated</b>	
I <sup>2</sup> C bus capacitance <sup>1</sup>	95 pF
Rise-time <sup>2</sup>	~220 ns
<b>I<sup>2</sup>C bus with Pull-up B isolated</b>	
I <sup>2</sup> C bus capacitance <sup>1</sup>	35 pF
Rise-time <sup>2</sup>	~150 ns
<b>Note:</b>	
<sup>1</sup> Bus capacitance calculated using measured rise time with equation 1 from the I <sup>2</sup> C-bus specification and user manual.	
<sup>2</sup> Rise time is defined as the time it takes for the I <sup>2</sup> C bus to rise from 0.3*V <sub>DD</sub> to 0.7*V <sub>DD</sub> .	

### 6.3.2. Temperature Sensor

**MCP9808** is a digital temperature sensor connected to the Explorer's I<sup>2</sup>C bus. The alert pin is connected to the CNANO socket IO-24.

- Accuracy:
  - ±0.25°C (typical) from -40°C to +125°C
  - ±0.5°C (maximum) from -20°C to +100°C
- User selectable measurement resolution:
  - 0.0625°C
  - 0.125°C
  - 0.25°C
  - 0.5°C
- User programmable temperature limits:
  - Temperature window limit
  - Critical temperature limit



**Info:** 7-bit I<sup>2</sup>C address: 0x1C. The I<sup>2</sup>C address can be changed using pins A0-A2 and follows the address format '0011, A2, A1, A0'.

Figure 6-4. Temperature Sensor

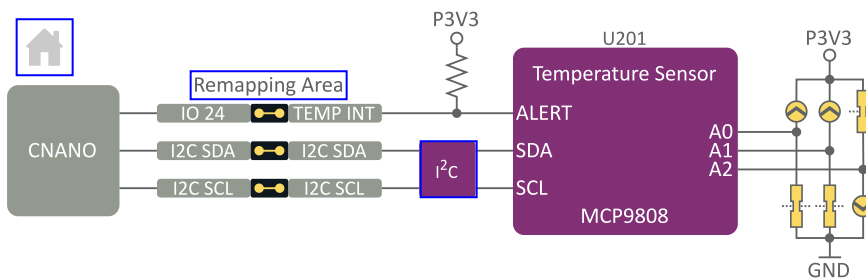

### 6.3.3. Secure Element

**ATECC608B** is a secure element in the Microchip CryptoAuthentication™ family and is connected to the Explorer's I<sup>2</sup>C bus.

- Supports advanced Elliptic Curve Cryptography (ECC)
- Protected storage for up to 16 keys, certificates or data
- Internal random number generator
- Secure boot support

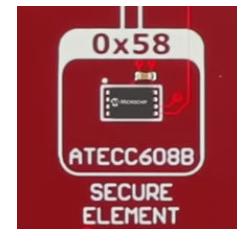

**Info:** 7-bit I<sup>2</sup>C address: 0x58.

Figure 6-5. Secure Element

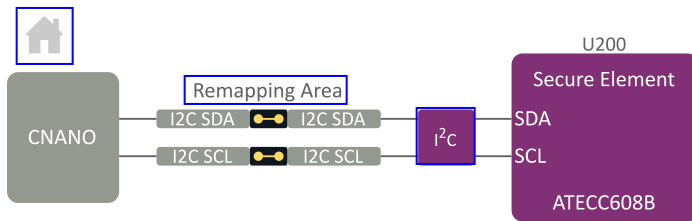

**Info:** The ATECC608B-MAH4I used on the Explorer is pre-provisioned for the Microchip Trust Platform and configured to support some of the most common IoT use cases. For more details, visit: <https://www.microchip.com/en-us/products/security/trust-platform/trustflex>.

### 6.3.4. Proximity and Ambient Light Sensor

VCNL4200 is a proximity sensor (PS) and ambient light sensor (ALS) connected to the Explorer's I<sup>2</sup>C bus.

- Programmable emitter current
- 16-bit resolution ALS
- 12-bit/16-bit resolution PS
- Detection distance of up to 1.5m
- Interrupt function available for ALS and PS with upper and lower thresholds



**Info:** 7-bit I<sup>2</sup>C address: 0x51.

Figure 6-6. Proximity and Ambient Light Sensor

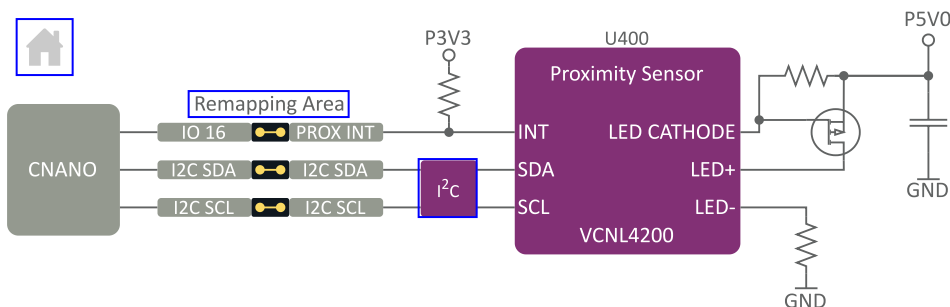

### 6.3.5. 2 Mb Serial EEPROM

[AT24CM02](#) is a 2 Mb Serial EEPROM connected to the Explorer's I<sup>2</sup>C bus.

- 1024 pages of 256 bytes each
- Random, byte and sequential read modes
- Byte and page write modes
- Built in error detection and correction
- Hardware write protection

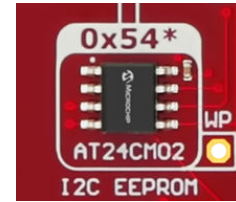

**Info:** 7-bit I<sup>2</sup>C address space: 0x54 - 0x57.

Figure 6-7. I<sup>2</sup>C EEPROM

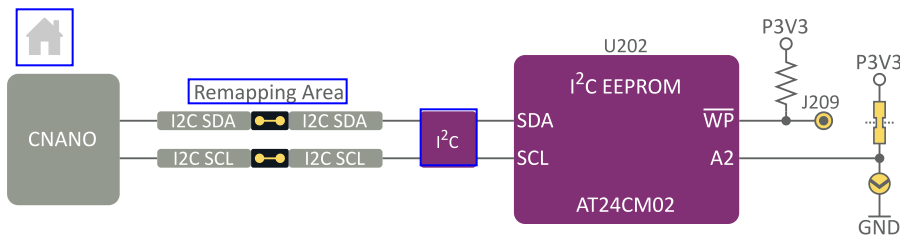

**Info:** The write protect pin is available through pin header footprint J209 and can be remapped to the CNANO socket.

### 6.3.6. I/O Expanders

The Explorer features two [MCP23008](#) I/O expanders connected to the I<sup>2</sup>C bus.

- 8-bit bidirectional I/O port
- I/O pins default to input
- Configurable interrupt output pin

I/O Expander 1 is set up to control the LED row containing eight yellow LEDs.

- See chapter [LED Row and I/O Expander 1](#) for more information.

I/O Expander 2 is set up to read the status of the joystick and tactile or touch buttons.

- See chapter [Buttons, Joystick and I/O Expander 2](#) for more information.

### 6.3.7. OLED Display Module

The Explorer features an OLED display connected to the I<sup>2</sup>C bus.

- SSD1306 display driver
- 1.30" screen size with 128x64 pixel resolution
- Fast response time ( $\leq 10 \mu\text{s}$ )
- Typical brightness: 120 cd/m<sup>2</sup>

**Info:** 7-bit I<sup>2</sup>C address: 0x3D. Alternative I<sup>2</sup>C address 0x3C can be used by connecting pin A0 to GND.

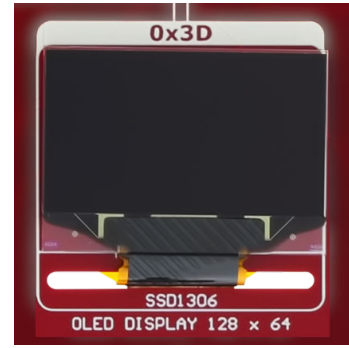
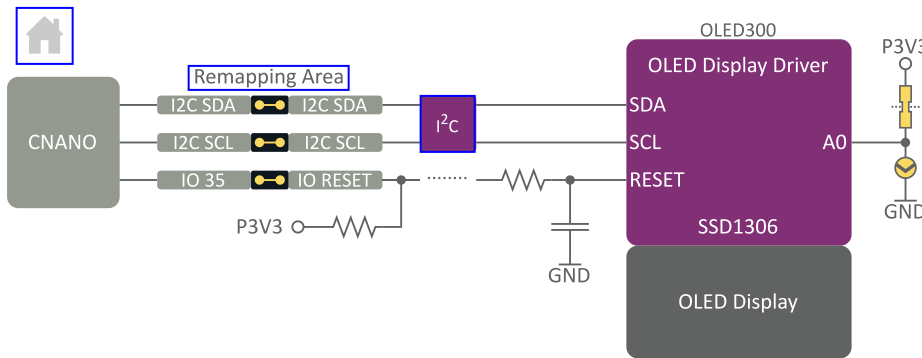

Figure 6-8. OLED Display



## 6.4. SPI Peripherals

### 6.4.1. SPI Bus

The Explorer features an SPI bus with several peripherals and a MikroBus socket attached. The individual Chip Select (CS) pins and the mutual SPI bus pins are routed to the CNANO socket.

Figure 6-9. SPI Bus Overview

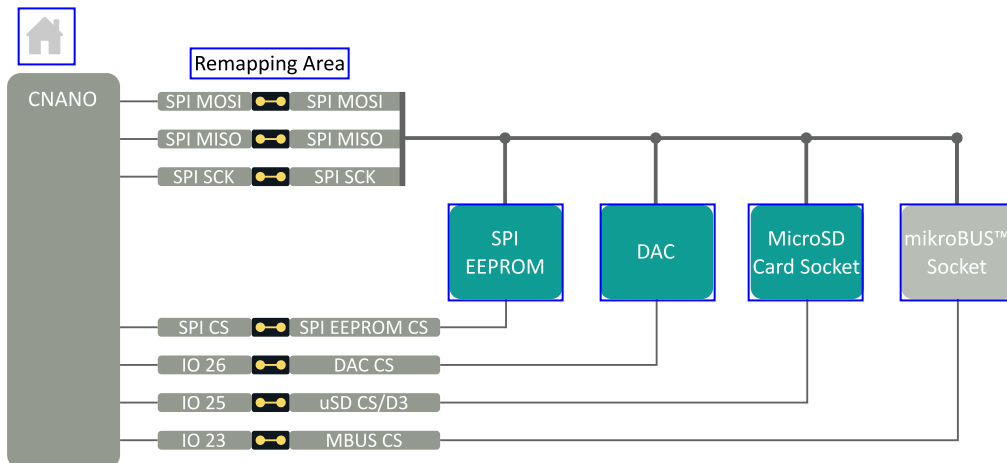

**Info:** A 47 kΩ pull-up resistor (R221) is mounted on the MISO line close to the microSD card socket, causing the MISO line to idle high.

### 6.4.2. Digital-to-Analog Converter

**MCP4821** is a single-channel 12-bit Digital-to-Analog converter (DAC) with internal voltage reference. The DAC is connected to the SPI bus on the Explorer.

- SPI with 20 MHz clock support
- 2.048V Internal voltage reference ( $V_{ref}$ )
- DAC output, limited by supply voltage (3.3V)
- Synchronous update of DAC output using the  $\overline{LDAC}$  pin

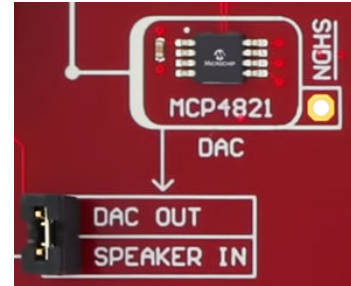

**Table 6-2.** Programmable Gain

Gain Selection	Ideal Output Range	LSb Size
2.048V	0.0-2.0475V	0.5 mV
4.096V	0.0-3.299V	1.0 mV

**Figure 6-10.** DAC Overview

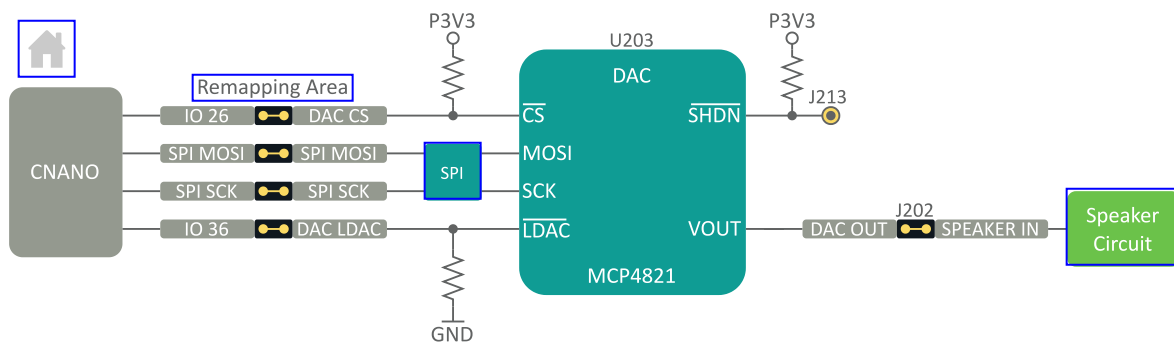

**Tip:** The DAC output is connected to the speaker circuit by default. It can be remapped using pin header J202.

### 6.4.3. 4 Mb Serial EEPROM

**25CSM04** is a 4 Mb Serial EEPROM connected to the Explorer's SPI bus.

- SPI with up to 8 MHz clock support
- 2048 pages of 256 bytes each
- Byte or sequential reads
- Byte or page writes
- Built-in Error Correction Code (ECC)
- Configurable software and/or hardware write protection

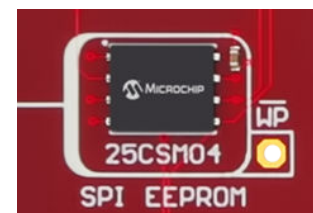
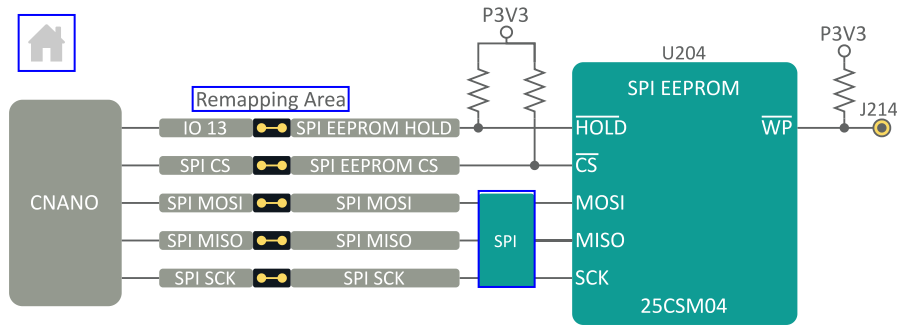

Figure 6-11. SPI EEPROM



**Tip:** Enable the hardware write-protected feature by pulling the  $\overline{WP}$  pin low.

#### 6.4.4. microSD Card Socket

The Explorer features a microSD card socket connected to its SPI bus. Only pins required for an SPI connection to a microSD card are connected to the CNANO socket.

All pins of the microSD card socket are available on pin headers close to the microSD card socket. The pin headers allow devices with a dedicated high-speed multimedia interface to fully utilize all data lines of a connected microSD card.

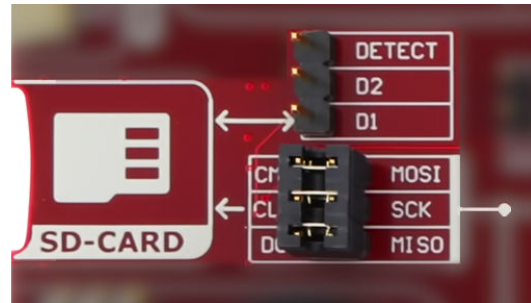

**Tip:** D1, D2, and the card detect pins are routed to a separate pin header (J212). With no card inserted, the card-detect pin is low.

Figure 6-12. microSD Card

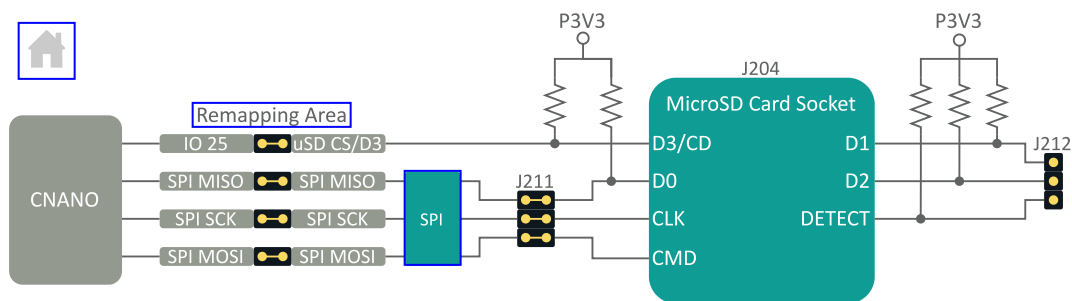

**Info:** A 47 k $\Omega$  pull-up resistor (R221) is mounted on the MISO line close to the microSD card socket, causing the MISO line to idle high.

## 7. Analog Peripherals

Microphone Circuit, Speaker Circuit, Rotary Potentiometer, Voltage Reference.

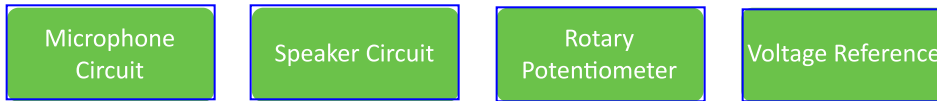

### 7.1. Microphone Circuit

A MEMS microphone is available as an analog input peripheral on the Explorer and is connected to its amplifier through the 1x2 pin header J206.

The dual operational amplifier MCP6022 is used to amplify the signal from the microphone with three selectable gain stages. The gain stages are 1, 221 (low) and 1001 (high), selectable using the slide switch S200.

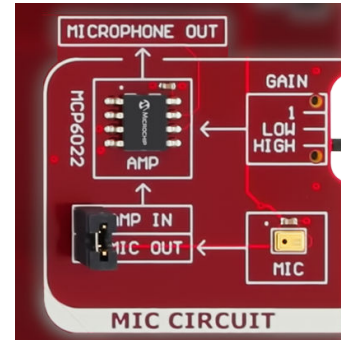
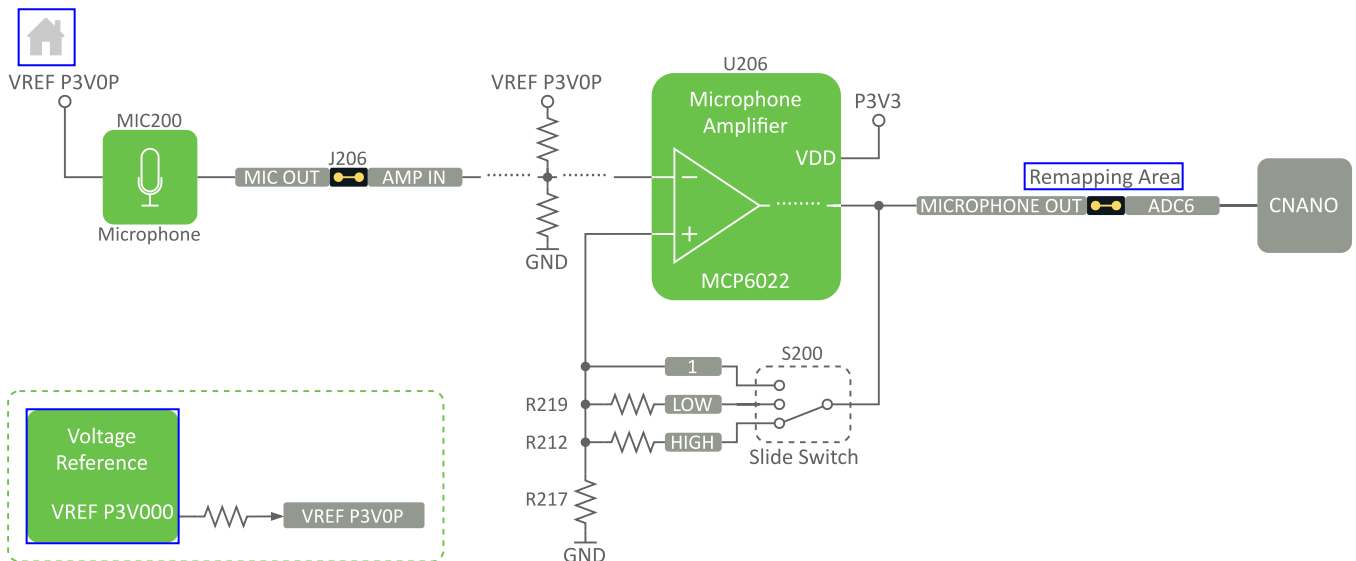

Figure 7-1. Microphone Circuit Overview



**Tip:** The microphone output can be disconnected from the amplifier and accessed directly through the 1x2 pin header J206.

## 7.2. Speaker Circuit

The Explorer features an 8Ω, 0.2W miniature speaker. The speaker amplifier input signal is, by default, connected to the output of the 12-bit DAC MCP4821.

A Class-D mono amplifier drives the speaker. Volume control is implemented with the rotary potentiometer R210, which provides an approximate logarithmic gain control for the amplifier input.

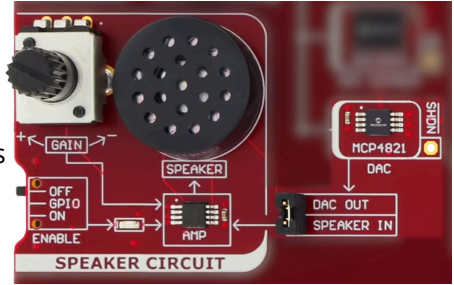

**Tip:** Pin header J202 can be used to remap the speaker input signal and/or DAC output.

Figure 7-2. Speaker Circuit Overview

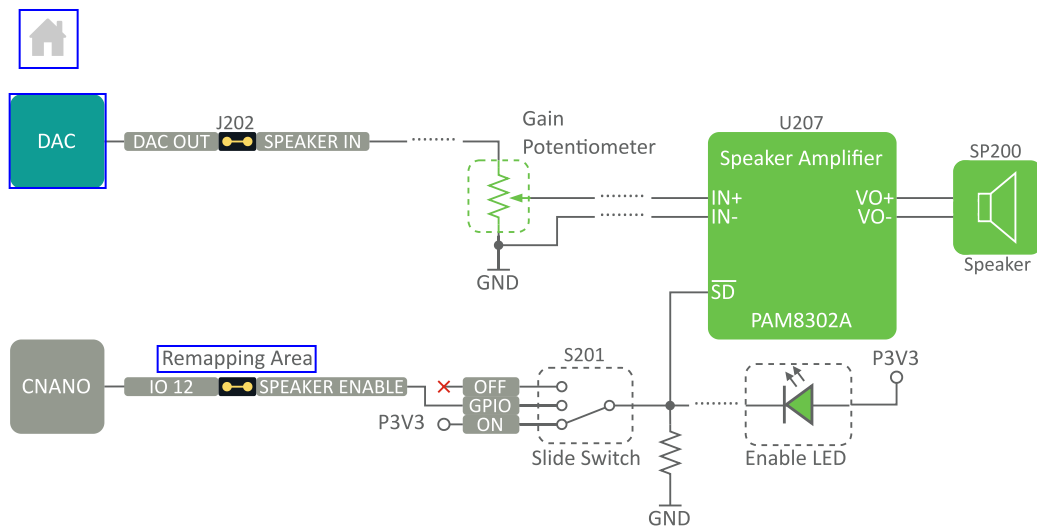

## 7.3. Rotary Potentiometer

A 10 kΩ ±20% rotary potentiometer is available to the user as an analog input (R421). The voltage output varies between 0V and 3.3V. The voltage output increases when turning the potentiometer clockwise.

Figure 7-3. Rotary Potentiometer

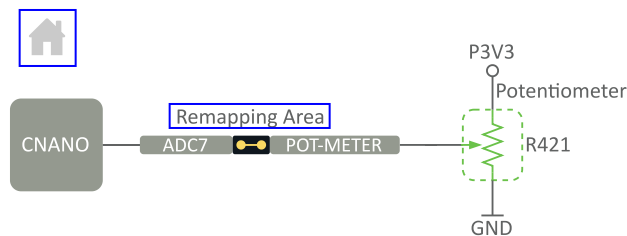

## 7.4. Voltage Reference

The MCP1501 voltage reference circuit serves two purposes.

- Power supply for the MEMS microphone
- Two accurate buffered voltage references, 1.50V and 3.00V, based on the MCP6V02 dual operational amplifier



Figure 7-4. Voltage Reference Overview

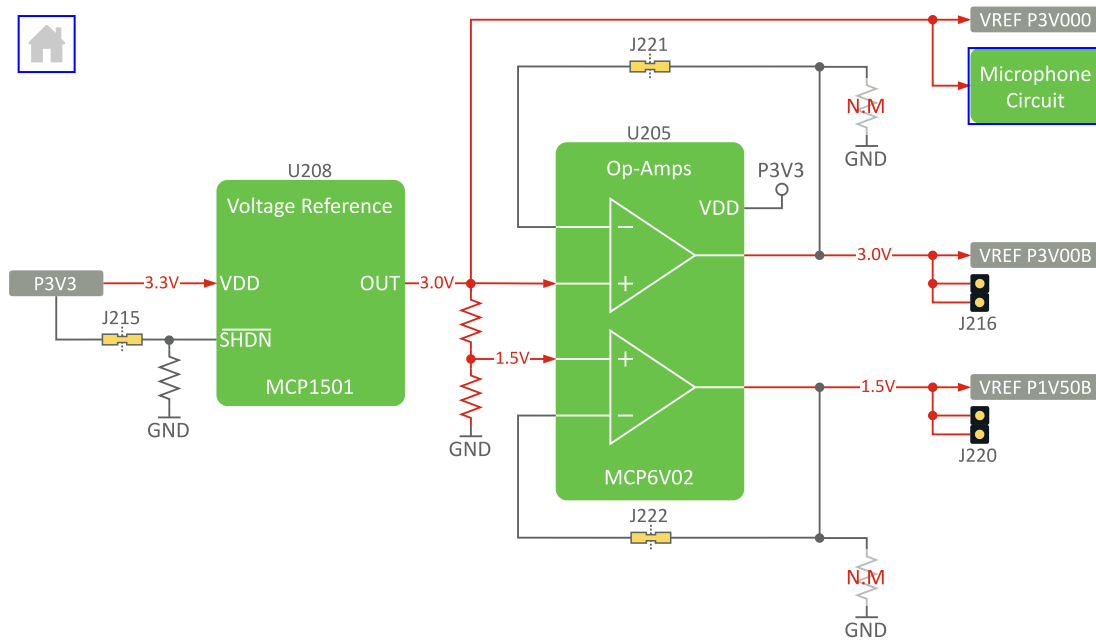

Table 7-1. Voltage Domain Specifications

Voltage Reference	Vnom	Vmin - Vmax	I <sub>max</sub>
VREF P3V000	3.000V	2.997-3.003V	20 mA
VREF P3V00B	3.00V	2.997-3.003V	5 mA
VREF P1V50B	1.50V	1.49-1.51V	5 mA

## 8. External Connectivity

Servomotor Headers, MikroBUS™, Grove, Qwiic®, PICkit™ Header.



### 8.1. Servomotor Headers

The Explorer features three-pin headers compatible with typical servomotor pinouts. The control signal of each pin header has a MOSFET-driven open-drain output.

The 5V supply on the board usually supplies the control signal and power output on the pin headers. External power can be supplied through pin header J310. Select between on-board and external power using pin header J308.

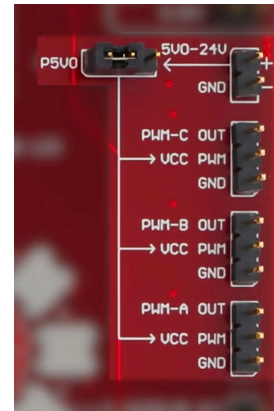

**Info:** The RGB LED will light up when driving servomotors and can be disconnected by removing pin jumpers from J309.

Figure 8-1. Servomotor Driver Circuit

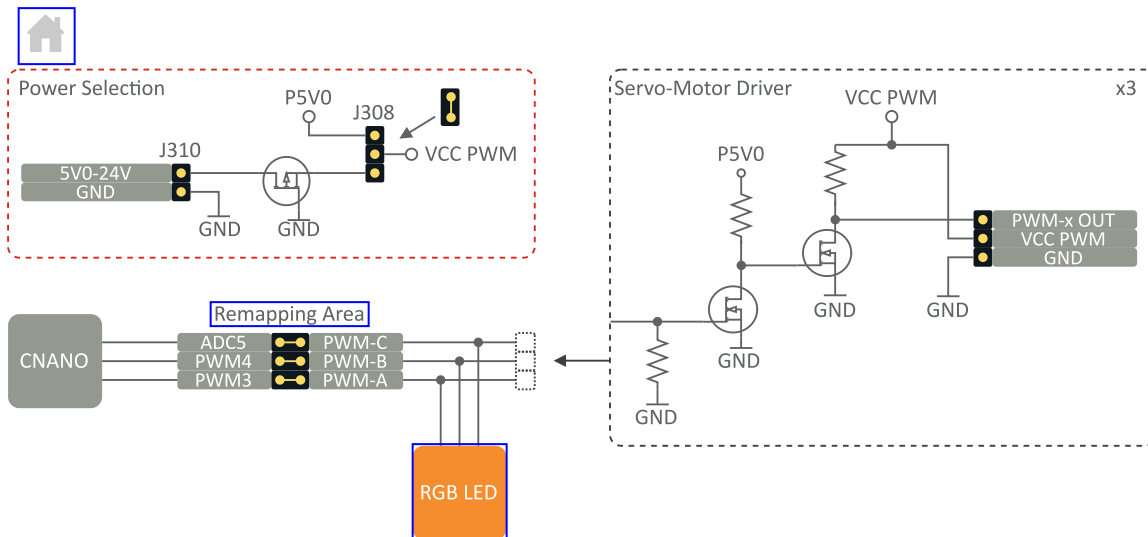

**Important:** Servomotors usually require high currents. It is recommended to use an external supply to power servomotors.

The circuit is rated for external power in the range of 5-24V.

## 8.2. MikroBUS™ Socket

The Explorer features a mikroBUS™ socket for Mikroelektronika Click boards™. The socket is connected to the Explorer's main I<sup>2</sup>C and SPI bus.

UART pins are shared between the USB bridge and the mikroBUS™ socket. Select your UART connections using the slide-switch S501.

The PWM pin is shared with the single RGB LED and servomotor driver and can be remapped with pin header J203.

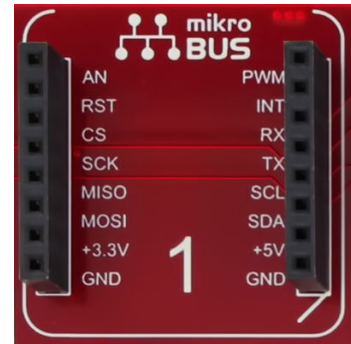
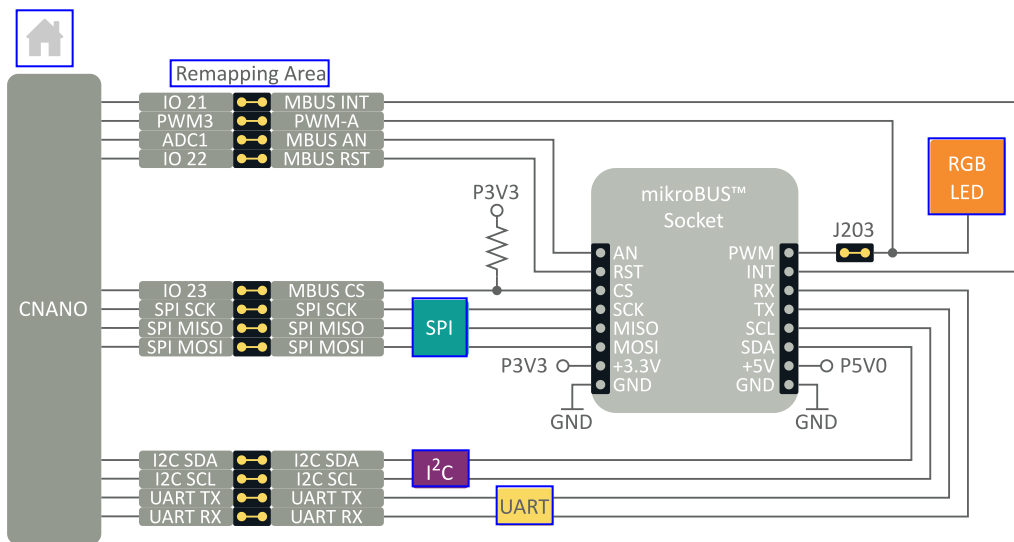

Figure 8-2. MikroBUS™ Socket



## 8.3. Grove

The Explorer features a Grove connector. The Grove system allows rapid prototyping using modular building blocks with many modules to choose from.

Figure 8-3. Grove Connector

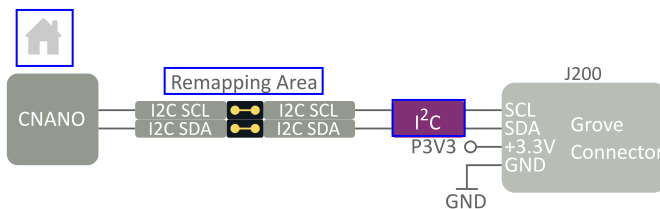
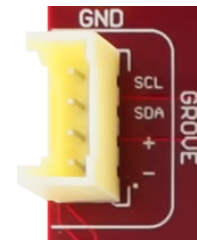

## 8.4. Qwiic<sup>®</sup>

The Explorer includes a 4-pin Qwiic<sup>®</sup> connector for easy daisy-chaining of multiple devices within the SparkFun Qwiic Connect System.



Figure 8-4. Qwiic Connector

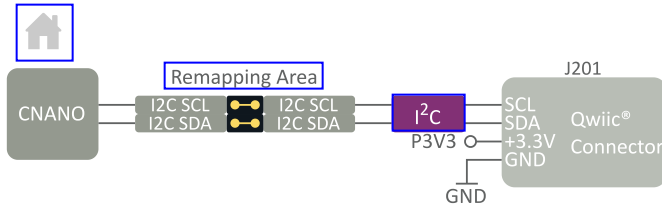

## 8.5. PICKit<sup>™</sup> Header

The Explorer has a 1x8 PICKit<sup>™</sup>-compatible connector footprint connected to the CNANO's debug pins.

A slide switch (S100) allows the user to select the programming interface for the connected CNANO. Position 1 for UPDI/ICSP<sup>™</sup> and position 2 for SWD.

To use a PICKit<sup>™</sup> with the Explorer, the user must insert the included 1x8 right-angled pin header into the staggered footprint J122.

**Tip:** For repeated use, it is recommended to solder in the 1x8 right-angled pin header.

Figure 8-5. Overview

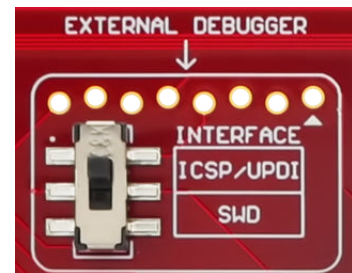
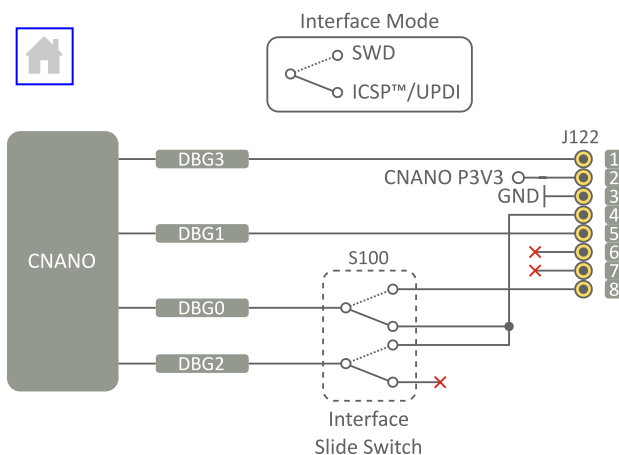

## 9. Hardware Revision History

### 9.1. Identifying Product ID and Revision

There are two ways to find the revision and product identifier of the Curiosity Nano Explorer: The MPLAB® X IDE Kit Window or the sticker on the bottom of the PCB.

The Kit Window appears in MPLAB X IDE when connecting a Curiosity Nano development board to the computer. An additional page for the Curiosity Nano Explorer shows when the CNANO is plugged into the socket on the board.

The first nine digits of the serial number, listed under kit information, contain the product identifier and revision.



**Tip:** If closed, the Kit Window can be opened in MPLAB X IDE through the menu bar **Window > Kit Window**.

The same information is found on the sticker on the bottom side of the PCB. The data matrix code on the sticker contains a string with the product identifier 02-00630, revision, and serial number.

The product identifier and revision are also printed in plain text as 02-00630/rr, where "rr" represents the revision. The serial number is printed on the following line.

The string in the data matrix code has the following format:

```
"nnnnnnnrrssssssss"
```

n = product identifier

r = revision

s = serial number

### 9.2. Hardware Revision History and Errata

This user guide provides information about the latest available revision of the board. Revision history and errata are available in the [Curiosity Nano Explorer Online Errata](#).

### 9.3. Document Revision History

Doc. Rev.	Date	Comments
B	8/2025	Updated to reflect Curiosity Nano Explorer Revision 4
A	6/2024	Initial document release

## 10. Appendix

MTCH1030 Touch Tune Data, Addressable LEDs Timing and Format, Schematics, Assembly Drawing. Schematics, and assembly drawing for the latest board revision are available as a PDF [here](#).

### 10.1. MTCH1030 Touch Tune Data

Touch sensor data captured with MTCH1030 can be visualized using the [MPLAB® Data Visualizer](#). UART data is output from MTCH1030 on the SW1 pin on the Explorer and can be streamed to the Data Visualizer through the on-board USB bridge.

**➔ Important:** Power off the Explorer before making any changes to the pin mapping.

To stream data from the MTCH1030, follow the steps below:

1. Remove the UART TX jumper cap in the pin remapping area.
2. Remove the SW1 jumper cap in the pin remapping area.
3. Make sure that the UART slide switch (S501) is set to connect the Explorer UART to the MCP2221A.
4. Connect the peripheral side of both SW1 and UART TX using a jumper wire.
5. Keep the mechanical SW2 button pressed while powering on the Explorer.
6. Follow the steps in the [MTCH1030 data sheet appendix](#) to configure the Data Visualizer.

**Figure 10-1.** Enabling Touch Tune Data

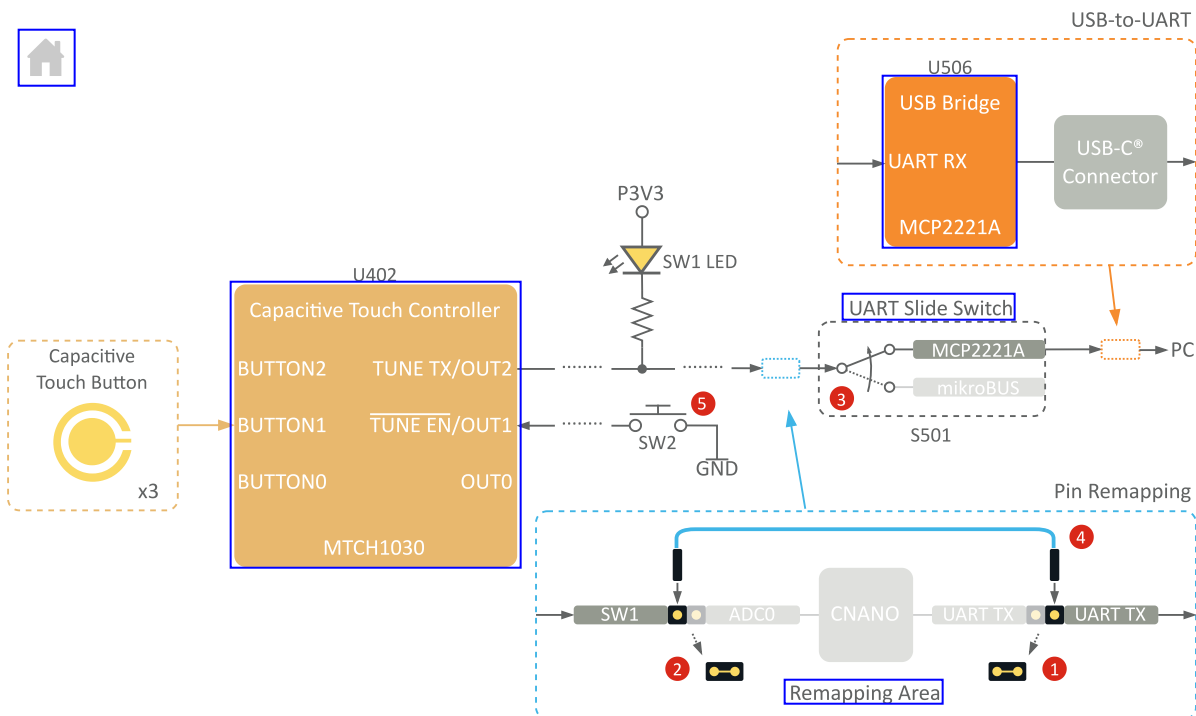

Related information: [Touch Controller](#)

## 10.2. Addressable LEDs Timing and Format

Lucklight manufactures the eight digital addressable LEDs on the Explorer. The manufacturer part number is FR5050RGB4C-F1A. They behave similarly to WS2812B LEDs but with slightly different timing information.

**Table 10-1.** Timing Characteristics

Data Transfer Time		
Parameter	Min. [ $\mu$ s]	Max. [ $\mu$ s]
T (Meta code cycle) <sup>1</sup>	1.2	--
T0H	0.2	0.4
T0L	0.8	--
T1L	0.7	1.0
T1H	0.2	--
Treset	>200	--

**Note:**

<sup>1</sup>The minimum requirement for the period is 1.2  $\mu$ s.

**Figure 10-2.** Sequence Chart

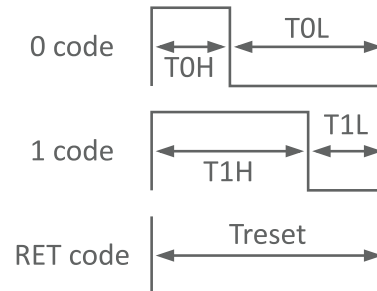

**Table 10-2.** 24-bit Data Format

G7	G6	G5	G4	G3	G2	G1	G0	R7	R6	R5	R4	R3	R2	R1	R0	B7	B6	B5	B4	B3	B2	B1	B0
----	----	----	----	----	----	----	----	----	----	----	----	----	----	----	----	----	----	----	----	----	----	----	----

The data bits must be sent one by one, starting with G7.

Related information: [Digital Addressable LEDs](#)

### 10.3. Schematics

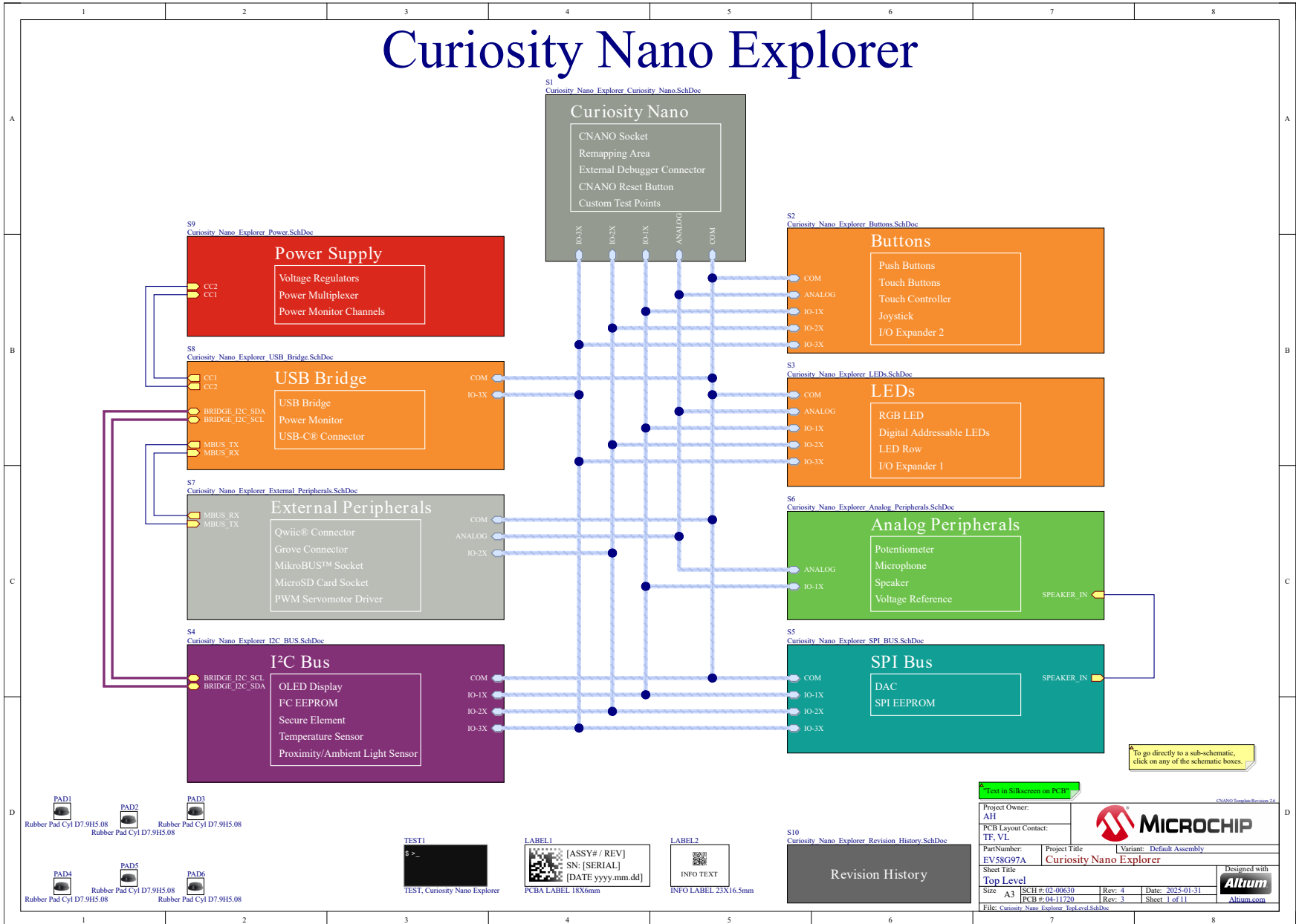

Figure 10-3. Curiosity Nano

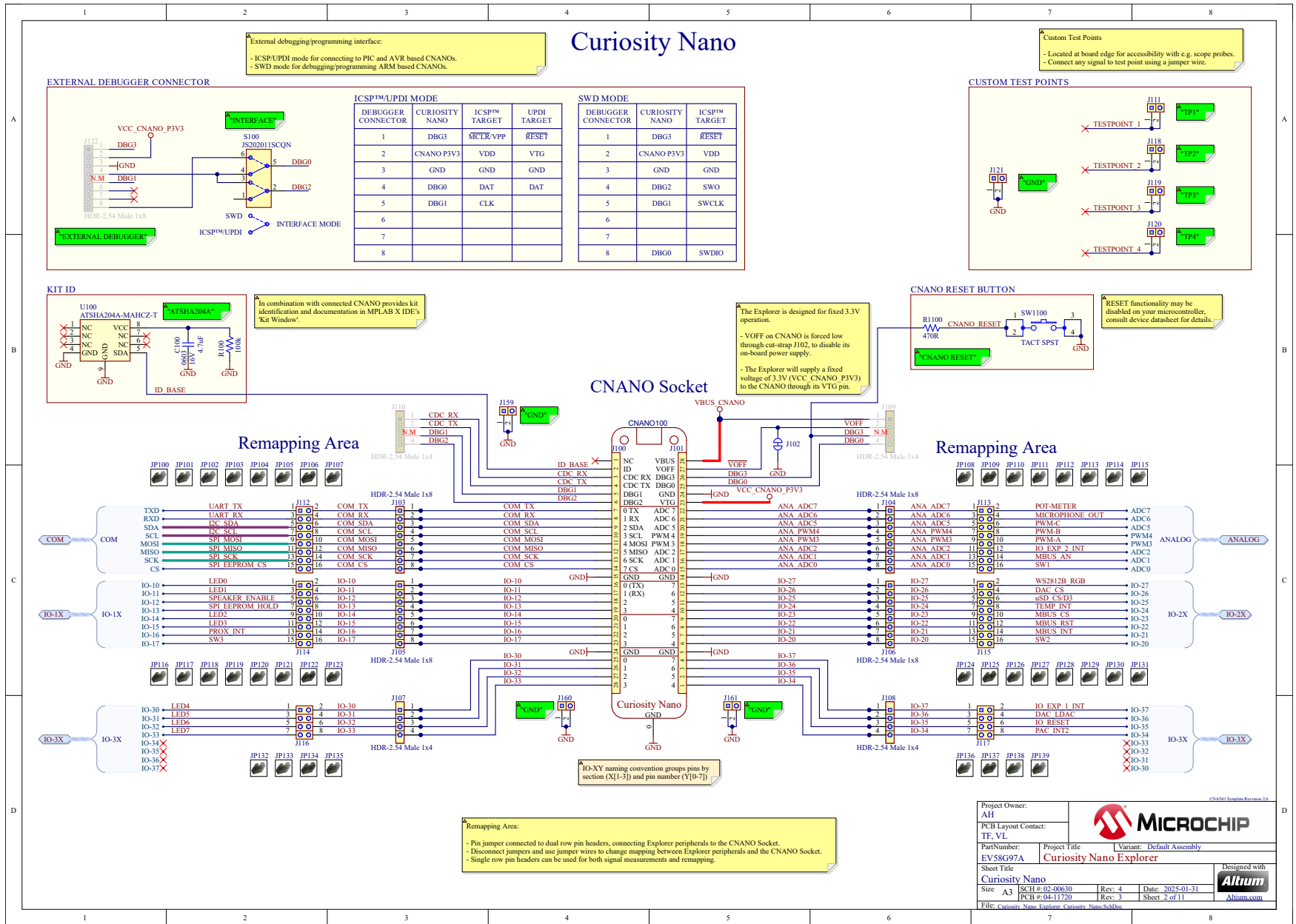
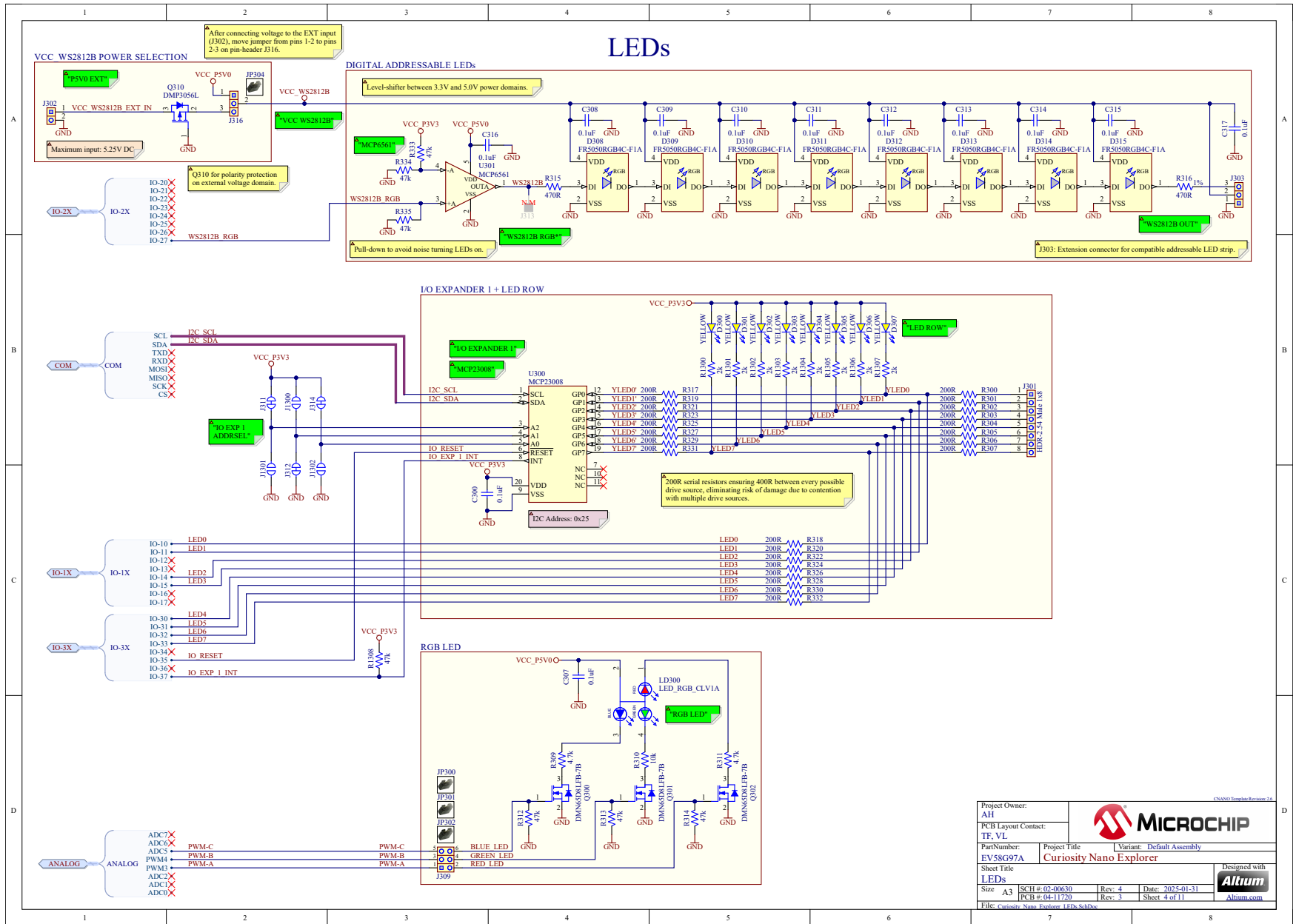

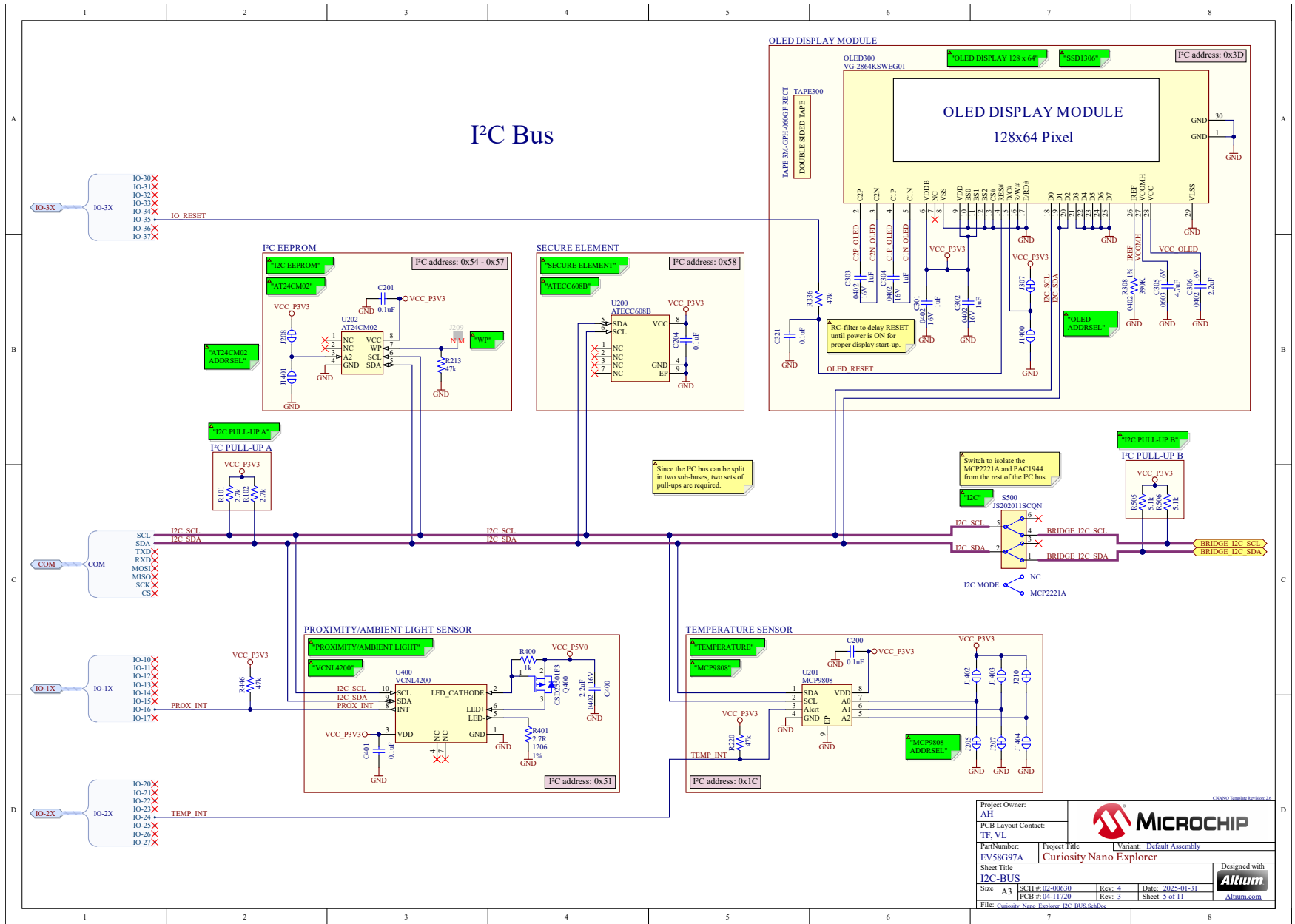

Figure 10-5. LEDs



Project Owner: AH			
PCB Layout Contact: TF, VL			
Part Number: EV58G97A		Project Title: Curiosity Nano Explorer	
Sheet Title: LEDs		Variant: Default Assembly	
Size: A3		Designed with: 	
SCH #: 02-00630		Rev: 4	
PCB #: 04-11720		Rev: 3	
Date: 2025-01-31		Sheet 4 of 11	
File: curiosity_nano_explorer_leds_schDoc			

Figure 10-6. I<sup>2</sup>C Bus



Project Owner: AH			
PCB Layout Contact: TF, VL			
Part Number: EV58G97A		Project Title Curiosity Nano Explorer	
Sheet Title I2C-BUS		Designed with 	
Size A3	SCH #: 02-00630	Rev: 4	Date: 2025-01-31
	PCB #: 04-11720	Rev: 3	Sheet 5 of 11
File: Curiosity Nano Explorer I2C-BUS.SchDoc			

Figure 10-7. SPI Bus

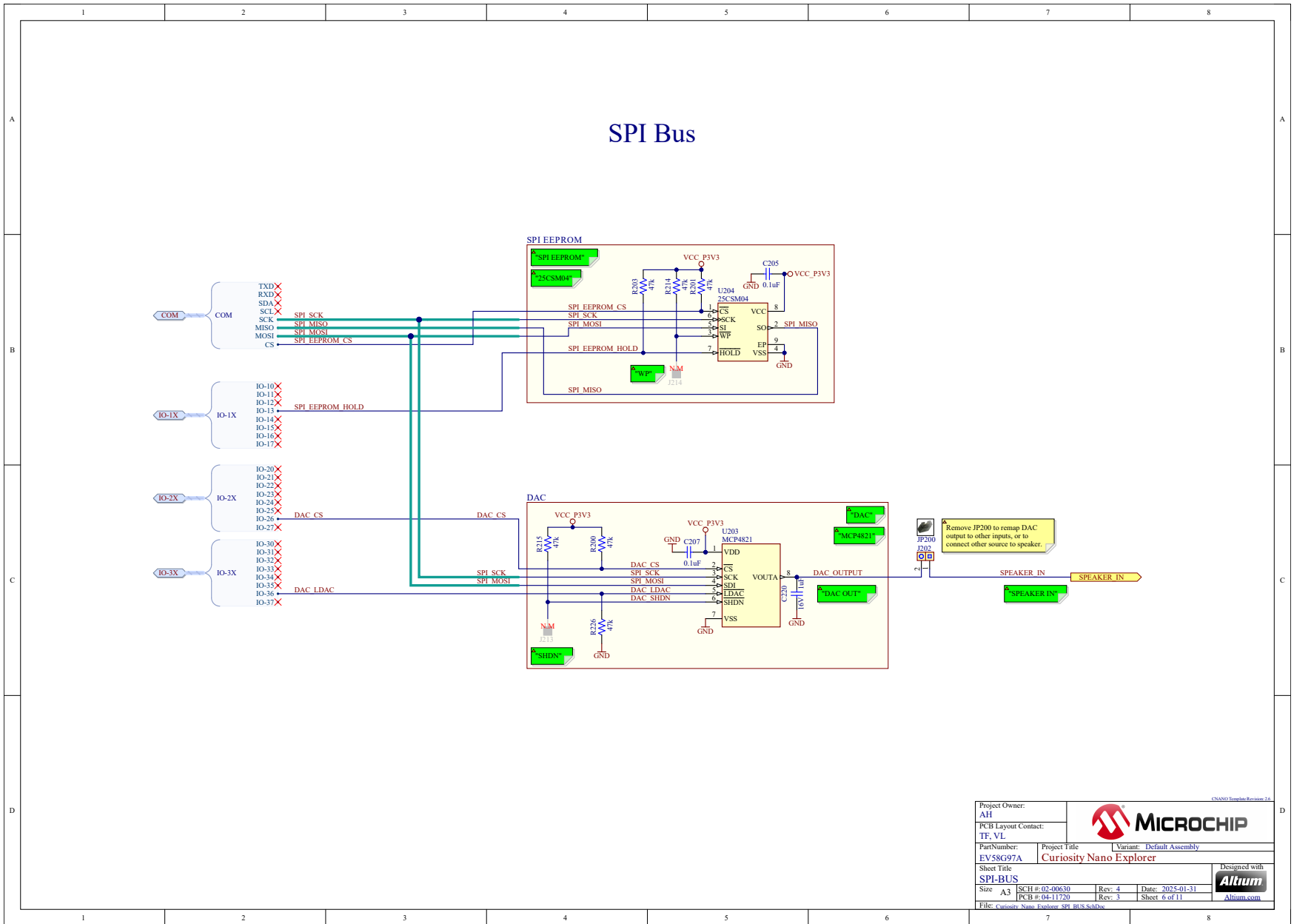

Project Owner: AH		Variant: Default Assembly	
PCB Layout Contact: TF, VL		Designed with 	
Part Number: EV58G97A		Project Title: Curiosity Nano Explorer	
Sheet Title: SPI-BUS			
Size A3	SCH #: 02-00630	Rev: 4	Date: 2025-01-31
	PCB #: 04-11720	Rev: 3	Sheet: 6 of 11
File: <i>curiosity_nano_explorer_spi_bus.schdoc</i>			

**Figure 10-8. Analog Peripherals**

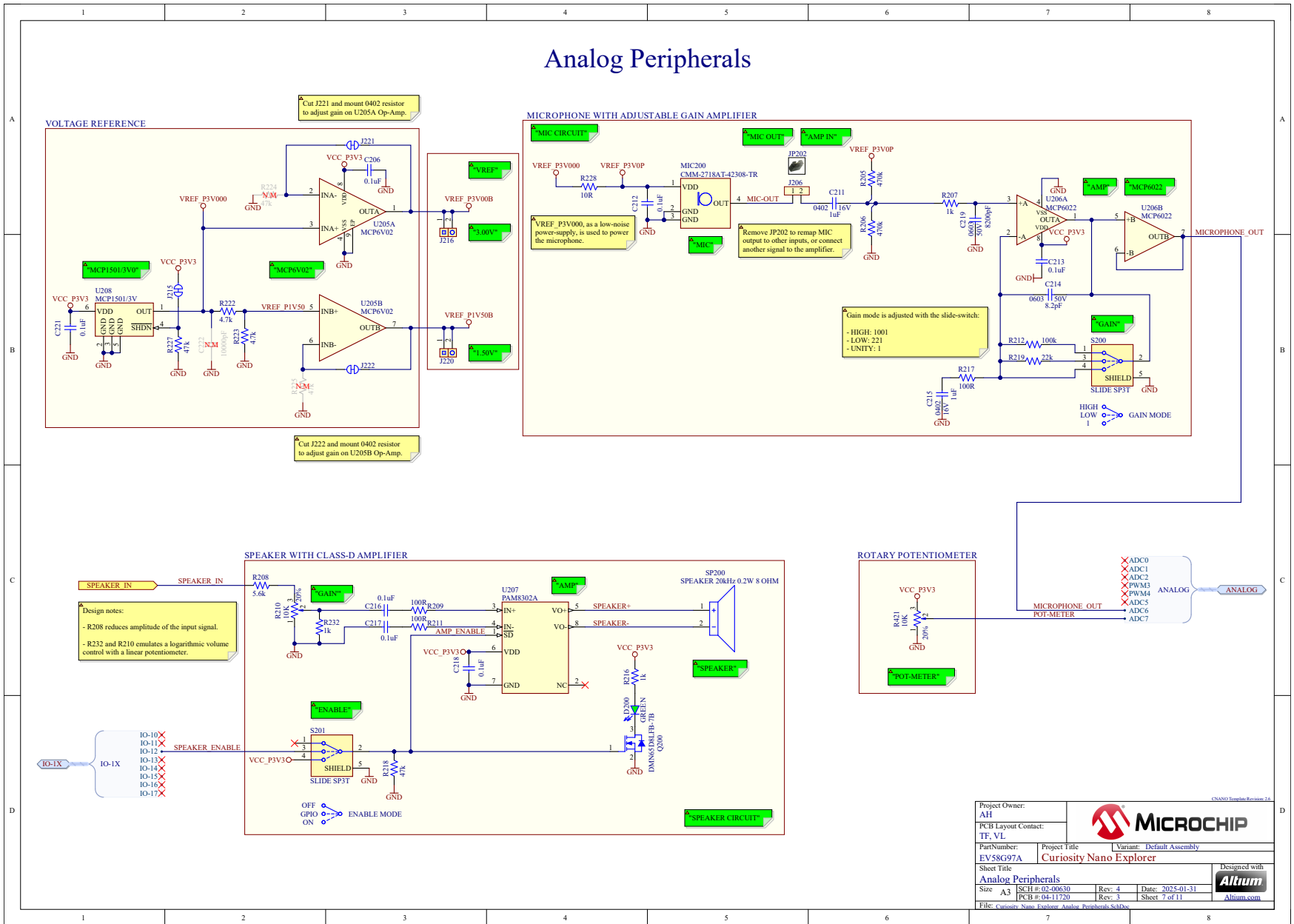

Project Owner: AH			
PCB Layout Contact: TF, VL			
Part Number: EV58C97A		Project Title: Curiosity Nano Explorer	
Sheet Title: Analog Peripherals		Variant: Default Assembly	
Size: A3		Designed with: 	
SCH #: 02-00630		Rev: 4	
PCB #: 04-11720		Date: 2025-01-31	
File: curiosity_nano_explorer_analog_peripherals.schDoc		Rev: 3	
		Sheet 7 of 11	
		Altium.com	

Figure 10-9. External Peripherals

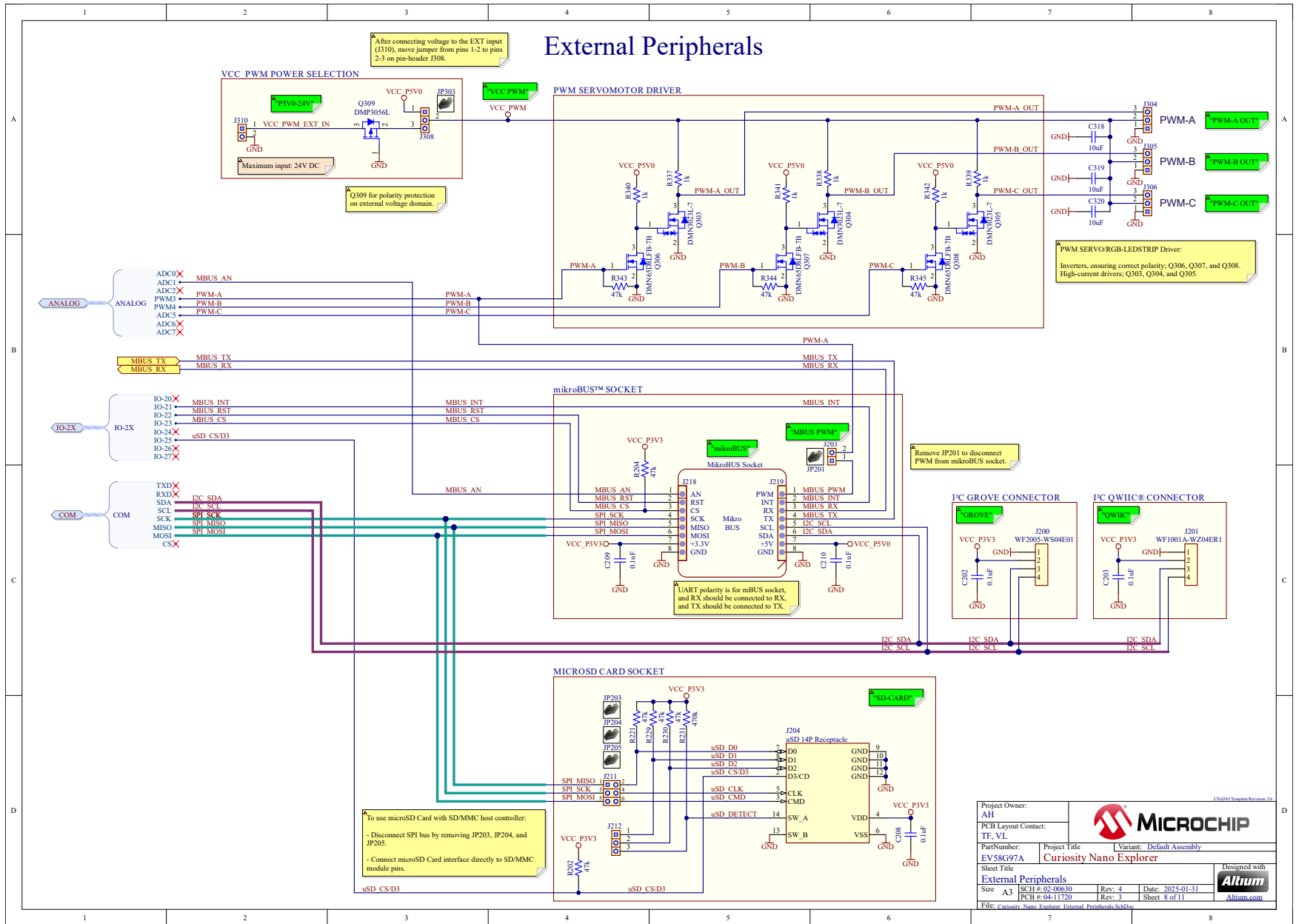
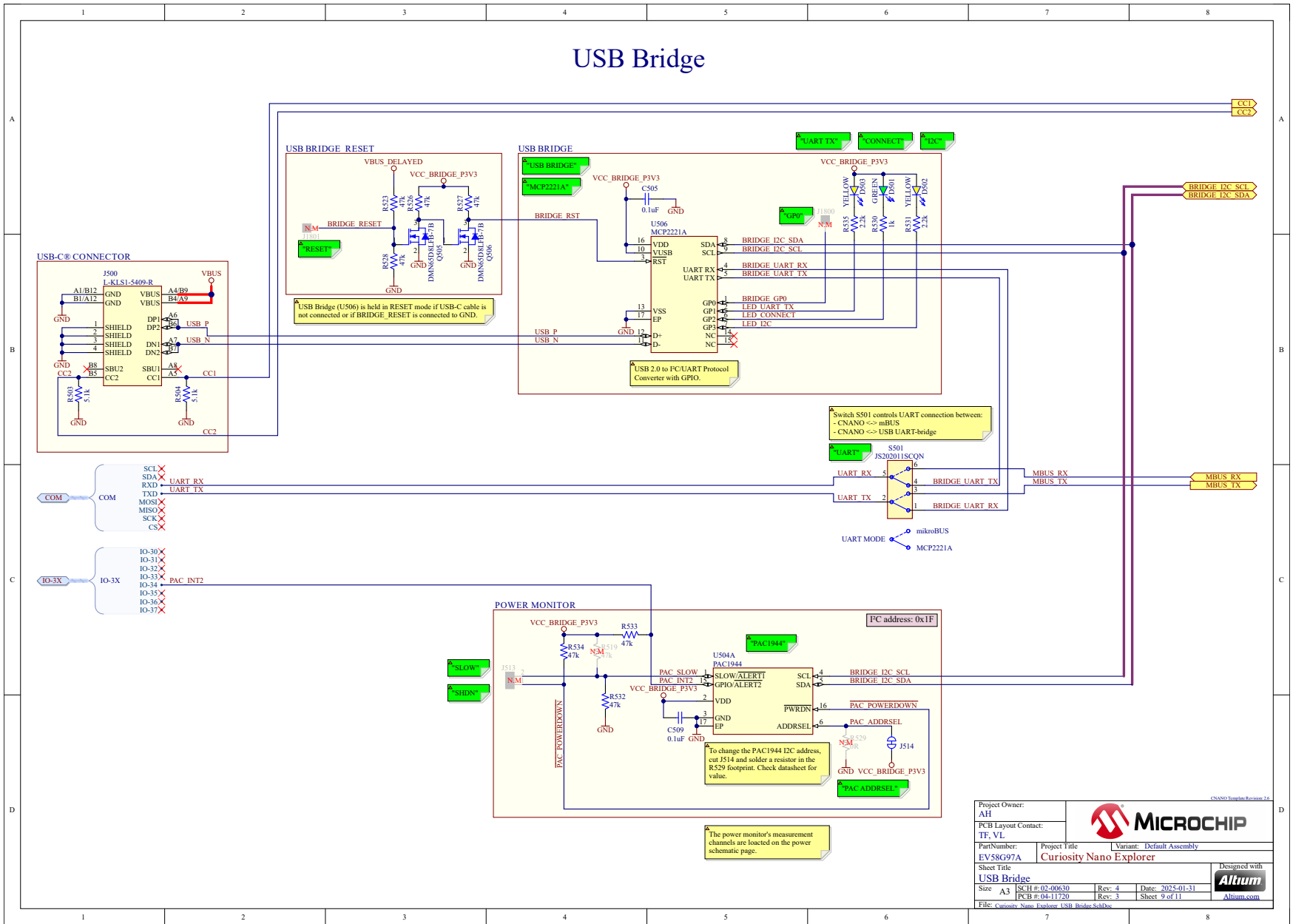
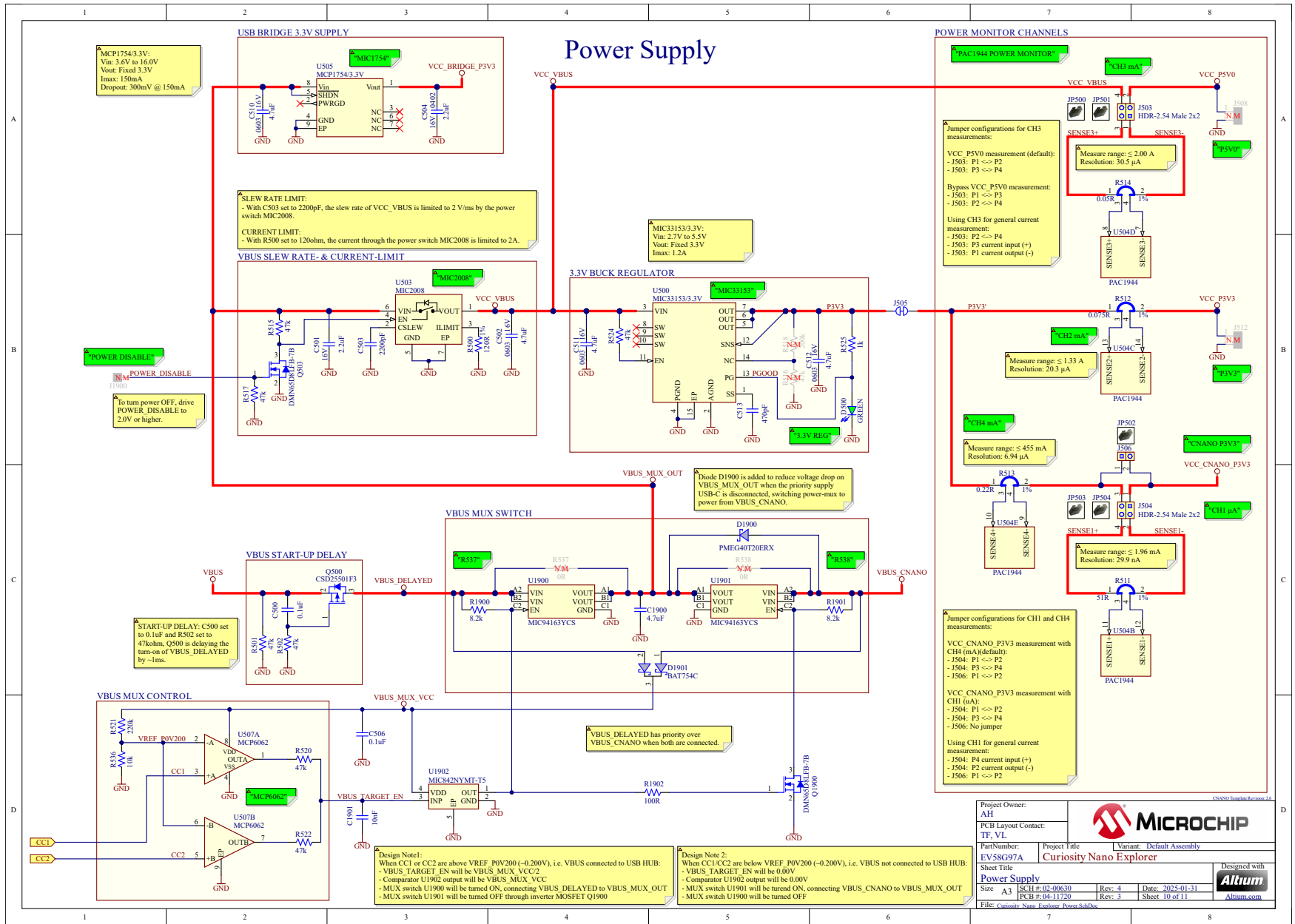

Figure 10-10. USB Bridge



Project Owner: AH			
PCB Layout Contact: TF, VL			
Part Number: EV58G97A	Project Title: Curiosity Nano Explorer	Variant: Default Assembly	
Sheet Title: USB Bridge		Designed with 	
Size A3	SCH #: 02-00630	Rev: 4	Date: 2025-01-31
	PCB #: 04-11720	Rev: 3	Sheet 9 of 11
File: <i>Curiosity Nano Explorer USB Bridge SchDoc</i>			

Figure 10-11. Power Supply



Project Owner: AH			
PCB Layout Contact: TF, VL		Variant: Default Assembly	
Part Number: EV58G97A		Project Title: Curiosity Nano Explorer	
Sheet Title: Power Supply		Designed with: 	
Size: A3	SC# #: 02-00630	Rev: 4	Date: 2025-01-31
PCB #: 04-11720	Rev: 3	Sheet 10 of 11	Altium.com
File: Curiosity Nano Explorer Power SubDoc			

# 10.4. Assembly Drawings

Figure 10-12. Curiosity Nano Explorer Top Assembly

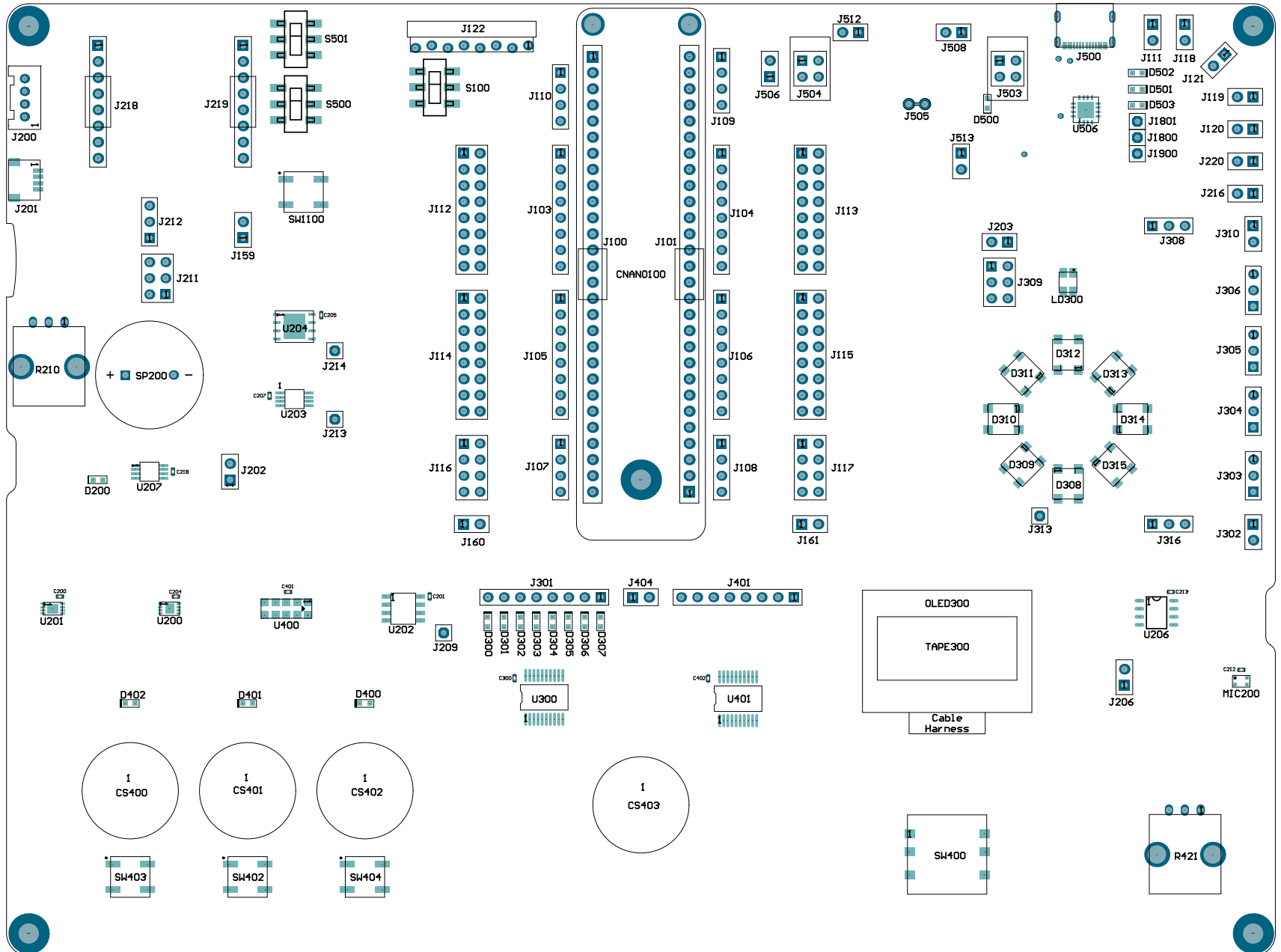
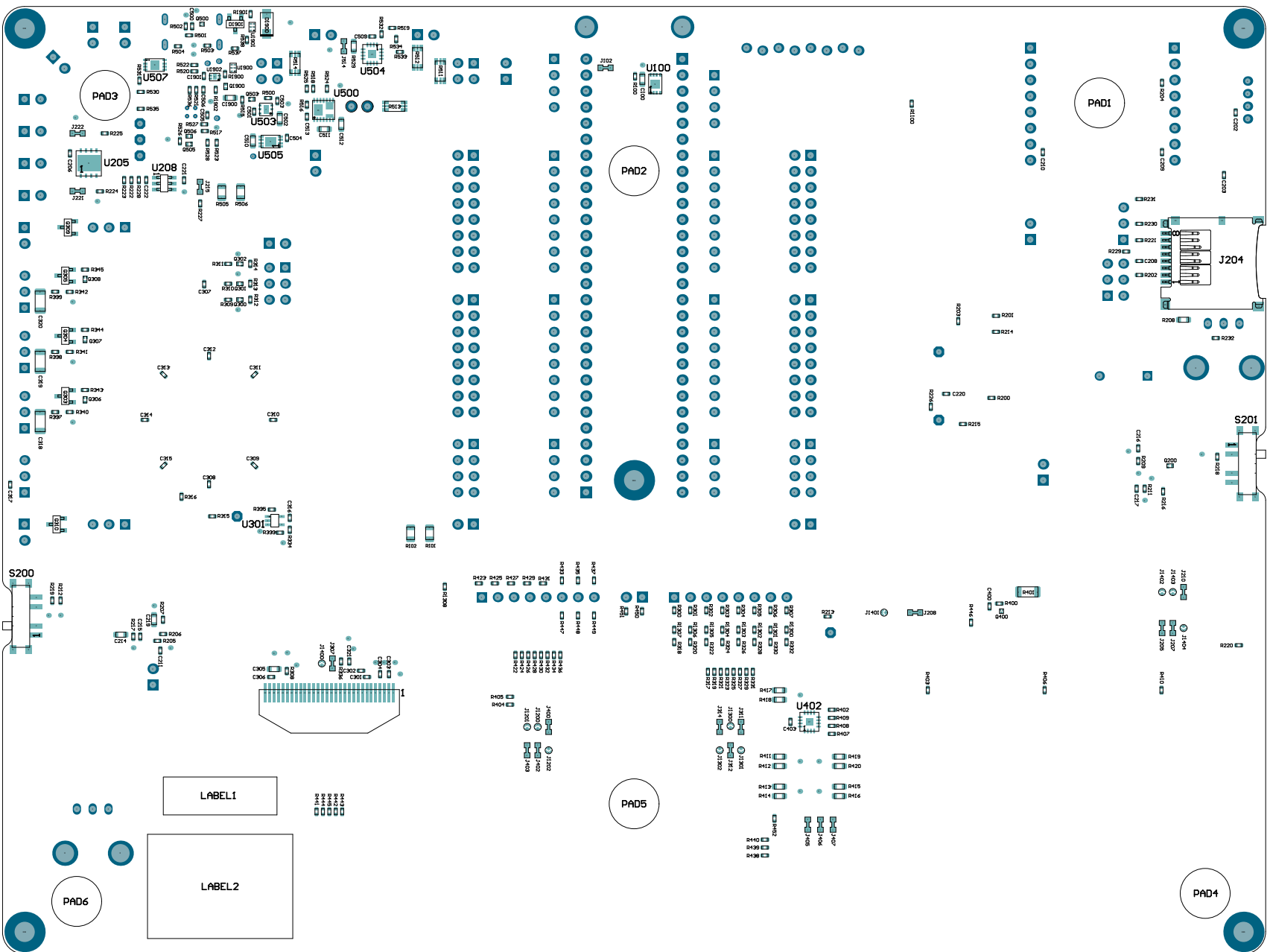

Figure 10-13. Curiosity Nano Explorer Bottom Assembly



## Microchip Information

### Trademarks

The “Microchip” name and logo, the “M” logo, and other names, logos, and brands are registered and unregistered trademarks of Microchip Technology Incorporated or its affiliates and/or subsidiaries in the United States and/or other countries (“Microchip Trademarks”). Information regarding Microchip Trademarks can be found at <https://www.microchip.com/en-us/about/legal-information/microchip-trademarks>.

ISBN: 979-8-3371-1733-1

### Legal Notice

This publication and the information herein may be used only with Microchip products, including to design, test, and integrate Microchip products with your application. Use of this information in any other manner violates these terms. Information regarding device applications is provided only for your convenience and may be superseded by updates. It is your responsibility to ensure that your application meets with your specifications. Contact your local Microchip sales office for additional support or, obtain additional support at [www.microchip.com/en-us/support/design-help/client-support-services](http://www.microchip.com/en-us/support/design-help/client-support-services).

THIS INFORMATION IS PROVIDED BY MICROCHIP “AS IS”. MICROCHIP MAKES NO REPRESENTATIONS OR WARRANTIES OF ANY KIND WHETHER EXPRESS OR IMPLIED, WRITTEN OR ORAL, STATUTORY OR OTHERWISE, RELATED TO THE INFORMATION INCLUDING BUT NOT LIMITED TO ANY IMPLIED WARRANTIES OF NON-INFRINGEMENT, MERCHANTABILITY, AND FITNESS FOR A PARTICULAR PURPOSE, OR WARRANTIES RELATED TO ITS CONDITION, QUALITY, OR PERFORMANCE.

IN NO EVENT WILL MICROCHIP BE LIABLE FOR ANY INDIRECT, SPECIAL, PUNITIVE, INCIDENTAL, OR CONSEQUENTIAL LOSS, DAMAGE, COST, OR EXPENSE OF ANY KIND WHATSOEVER RELATED TO THE INFORMATION OR ITS USE, HOWEVER CAUSED, EVEN IF MICROCHIP HAS BEEN ADVISED OF THE POSSIBILITY OR THE DAMAGES ARE FORESEEABLE. TO THE FULLEST EXTENT ALLOWED BY LAW, MICROCHIP’S TOTAL LIABILITY ON ALL CLAIMS IN ANY WAY RELATED TO THE INFORMATION OR ITS USE WILL NOT EXCEED THE AMOUNT OF FEES, IF ANY, THAT YOU HAVE PAID DIRECTLY TO MICROCHIP FOR THE INFORMATION.

Use of Microchip devices in life support and/or safety applications is entirely at the buyer’s risk, and the buyer agrees to defend, indemnify and hold harmless Microchip from any and all damages, claims, suits, or expenses resulting from such use. No licenses are conveyed, implicitly or otherwise, under any Microchip intellectual property rights unless otherwise stated.

### Microchip Devices Code Protection Feature

Note the following details of the code protection feature on Microchip products:

- Microchip products meet the specifications contained in their particular Microchip Data Sheet.
- Microchip believes that its family of products is secure when used in the intended manner, within operating specifications, and under normal conditions.
- Microchip values and aggressively protects its intellectual property rights. Attempts to breach the code protection features of Microchip products are strictly prohibited and may violate the Digital Millennium Copyright Act.
- Neither Microchip nor any other semiconductor manufacturer can guarantee the security of its code. Code protection does not mean that we are guaranteeing the product is “unbreakable”. Code protection is constantly evolving. Microchip is committed to continuously improving the code protection features of our products.

## Product Page Links

[25CSM04](#), [AT24CM02](#), [ATECC608B](#), [ATSHA204A](#), [MCP1501](#), [MCP2221A](#), [MCP23008](#), [MCP4821](#), [MCP6022](#), [MCP9808](#), [MTCH1030](#), [PAC1944](#)