

Main Product Characteristics

$V_{(BR)DSS}$	30V
$R_{DS(ON)}$	10mΩ (Max.)
I_D	50A

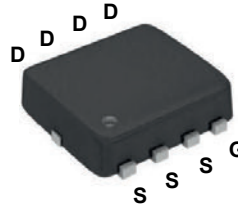

PPAK3x3

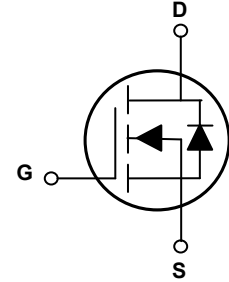

Schematic Diagram

Features and Benefits

- Advanced MOSFET process technology
- Ideal for high efficiency switched mode power supplies
- Low on-resistance with low gate charge
- Fast switching and reverse body recovery



Description

The GSFN3110 utilizes the latest techniques to achieve high cell density and low on-resistance. These features make this device extremely efficient and reliable for use in high efficiency switch mode power supplies and a wide variety of other applications.

Absolute Maximum Ratings ($T_C=25^{\circ}C$ unless otherwise specified)

Parameter	Symbol	Max.	Unit
Drain-Source Voltage	V_{DS}	30	V
Gate-to-Source Voltage	V_{GS}	±20	V
Continuous Drain Current, $T_C=25^{\circ}C$	I_D	50	A
Continuous Drain Current, $T_C=70^{\circ}C$		36	A
Pulsed Drain Current ¹	I_{DM}	200	A
Power Dissipation ($T_C=25^{\circ}C$)	P_D	35	W
Power Dissipation - Derate Above 25°C		0.28	W/°C
Single Pulse Avalanche Energy ²	E_{AS}	13	mJ
Single Pulse Avalanche Current ²	I_{AS}	16	A
Thermal Resistance, Junction-to-Case	$R_{\theta JC}$	3.58	°C/W
Operating Junction and Storage Temperature Range	T_J/T_{STG}	-55 to +150	°C

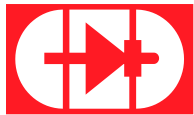
Electrical Characteristics ($T_J=25^\circ\text{C}$ unless otherwise specified)

Parameter	Symbol	Conditions	Min.	Typ.	Max.	Unit
On / Off Characteristics						
Drain-Source Breakdown Voltage	$V_{(BR)DSS}$	$V_{GS}=0V, I_D=250\mu A$	30	-	-	V
BV_{DSS} Temperature Coefficient	$\Delta BV_{DSS}/\Delta T_J$	Reference to 25°C $I_D=1mA$	-	0.04	-	$V/^\circ\text{C}$
Drain-Source Leakage Current	I_{DSS}	$V_{DS}=30V, V_{GS}=0V,$ $T_J=25^\circ\text{C}$	-	-	1	μA
		$V_{DS}=30V, V_{GS}=0V,$ $T_J=125^\circ\text{C}$	-	-	10	μA
Gate-Source Leakage Current	I_{GSS}	$V_{GS}=\pm 20V, V_{DS}=0V$	-	-	± 100	nA
Static Drain-Source On-Resistance ³	$R_{DS(ON)}$	$V_{GS}=10V, I_D=11A$	-	7.4	10	$m\Omega$
		$V_{GS}=4.5V, I_D=7A$	-	10.5	16	$m\Omega$
Gate Resistance	R_G	$V_{GS}=0V, V_{DS}=0V,$ $F=1MHz$	-	2.8	5.6	Ω
Gate Threshold Voltage	$V_{GS(th)}$	$V_{GS}=V_{DS}, I_D=250\mu A$	1.1	1.8	2.5	V
$V_{GS(th)}$ Temperature Coefficient	$\Delta V_{GS(th)}$		-	-4	-	$mV/^\circ\text{C}$
Forward Transconductance	g_{fs}	$V_{DS}=10V, I_D=3A$	-	6	-	S
Dynamic and Switching Characteristics						
Total Gate Charge ^{3,4}	Q_g	$V_{DS}=15V, I_D=5A$ $V_{GS}=4.5V$	-	8.6	14	nC
Gate-Source Charge ^{3,4}	Q_{gs}		-	2.3	5	
Gate-to-Drain Charge ^{3,4}	Q_{gd}		-	3	6	
Turn-On Delay Time ^{3,4}	$t_{d(on)}$	$V_{DD}=15V, R_G=6\Omega$ $V_{GS}=10V, I_D=1A$	-	3.8	7	nS
Rise Time ^{3,4}	t_r		-	10	19	
Turn-Off Delay Time ^{3,4}	$t_{d(off)}$		-	22	42	
Fall Time ^{3,4}	t_f		-	6.6	13	
Input Capacitance	C_{iss}	$V_{DS}=25V, V_{GS}=0V,$ $F=1MHz$	-	880	1700	pF
Output Capacitance	C_{oss}		-	89	125	
Reverse Transfer Capacitance	C_{rss}		-	68	90	
Drain-Source Diode Characteristics and Maximum Ratings						
Continuous Source Current	I_S	$V_G=V_D=0V,$ Force Current	-	-	50	A
Pulsed Source Current ³	I_{SM}		-	-	200	A
Diode Forward Voltage ³	V_{SD}	$V_{GS}=0V, I_S=1A,$ $T_J=25^\circ\text{C}$	-	-	1	V

Note:

1. Repetitive rating: Pulsed width limited by maximum junction temperature.
2. $V_{DD}=25V, V_{GS}=10V, L=0.1mH, I_{AS}=16A, R_G=25\Omega,$ Starting $T_J=25^\circ\text{C}$.
3. The data tested by pulsed, pulse width $\leq 300\mu s,$ duty cycle $\leq 2\%$.
4. Essentially independent of operating temperature.

Typical Electrical and Thermal Characteristic Curves

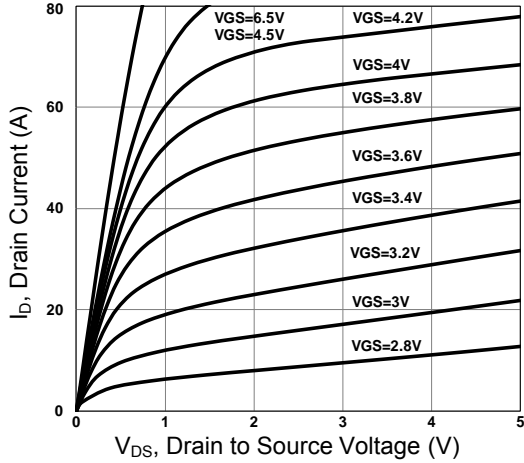

Figure 1. Output Characteristics

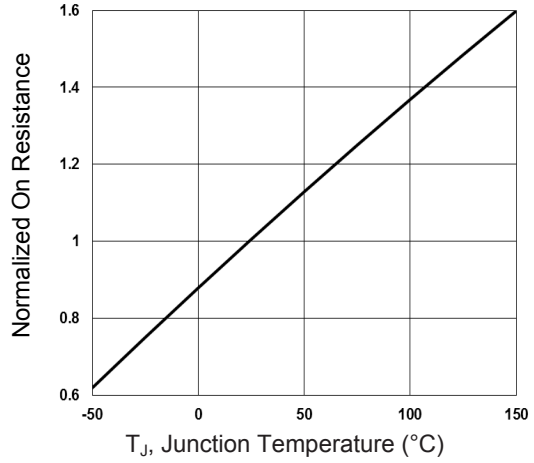

Figure 2. Normalized $R_{DS(ON)}$ Vs. T_J

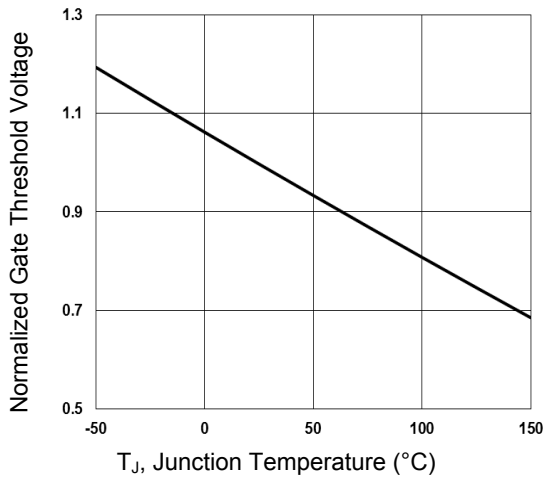

Figure 3. Normalized V_{th} Vs. T_J

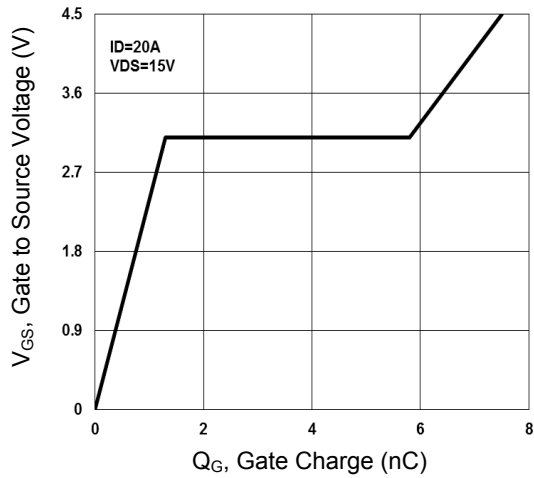

Figure 4. Gate Charge Characteristics

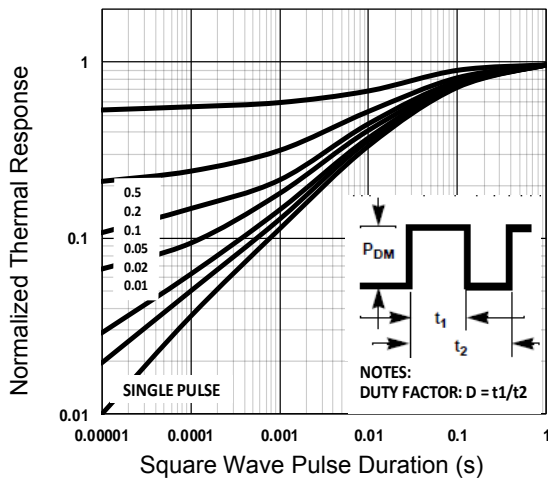

Figure 5. Normalized Transient Impedance

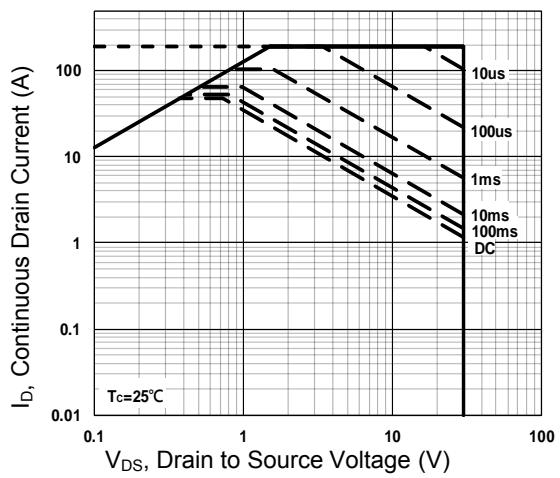
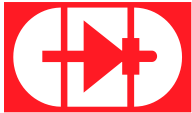
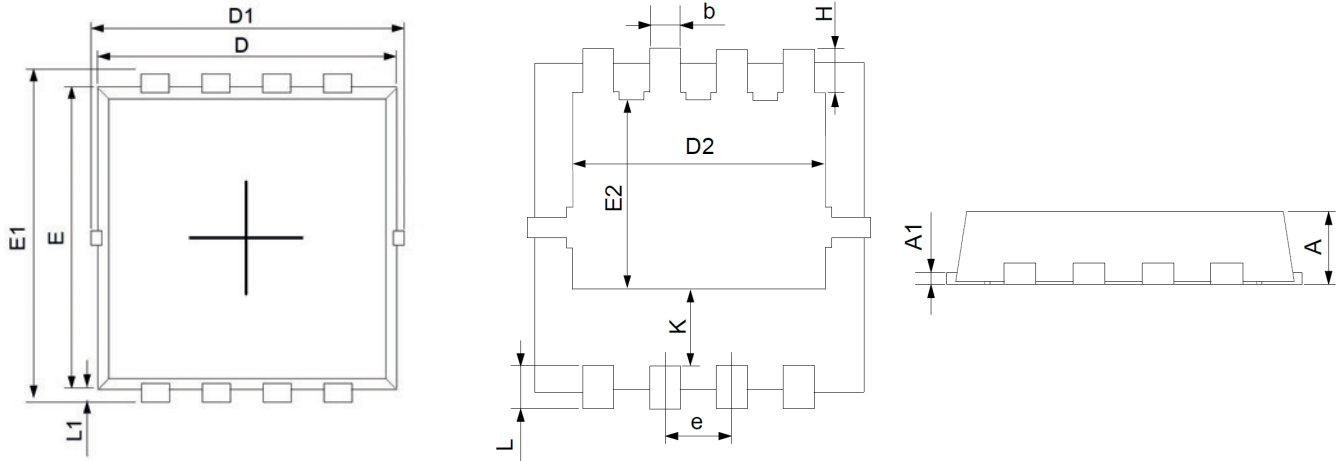

Figure 6. Maximum Safe Operation Area



Package Outline Dimensions (PPAK3x3)



Symbol	Dimensions In Millimeters		Dimensions In Inches	
	Min.	Max.	Min.	Max.
A	0.70	0.90	0.028	0.035
A1	0.14	0.20	0.006	0.008
D	3.05	3.25	0.120	0.128
E	2.90	3.10	0.114	0.122
D1	3.10	3.50	0.122	0.138
D2	2.35	2.50	0.093	0.098
E1	3.10	3.50	0.122	0.138
E2	1.64	1.84	0.065	0.072
b	0.25	0.35	0.010	0.014
K	0.59	0.79	0.023	0.031
e	0.55	0.75	0.022	0.030
L	0.25	0.55	0.010	0.022
L1	0.10	0.20	0.004	0.008
H	0.32	0.52	0.013	0.020

Order Information

Device	Package	Marking	Carrier	Quantity
GSFN3110	PPAK3x3	N3110	Tape & Reel	5,000pcs / Reel

For more information, please contact us at: inquiry@goodarksemi.com