

Crystal Clock Oscillator

■ NZ2016SH Data Sheet Standard Type

Application

For Automotive navigation system, Automotive audio equipment and Camera

For Smartphone, Tablet computers, Notebook PC, PC card, etc.

For Audio equipment and Wireless module

For Communication equipment for SDH/SONET, WiMAX, LTE, etc. and Base station

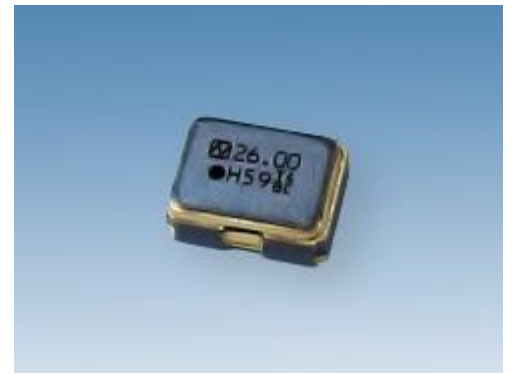

RoHS Compliant
Directive 2011/65/EU
Directive (EU) 2015/863

Pb free

AEC
Q100/Q200

Features

- Supports a wide temperature range from -40 to +125 °C.
- Ultra compact and light. Dimensions : 2.0 x 1.6 x 0.7 mm, weight : 0.01 g.
- This crystal clock oscillator can support low frequencies (6.5 MHz ~ 160 MHz) not easily achieved with crystal units of the same size.
- Low phase jitter (Typ. 100 fs (Frequency Offset : 12 kHz to 20 MHz)@80 MHz, 3.3 V)
- Taped units enable automatic mounting IR Reflow (lead free) is possible.
- Lead-free.
- Conforms to AEC-Q100/Q200.

1. Item : Crystal Clock Oscillator
 2. Type : NZ2016SH
 3. Nominal Frequency : 6.5 to 160 MHz
 4. NDK Spec. No. : See Table1

5. Maximum Ratings

	Item	Ratings			Notes
		min	max	Units	
1	Supply Voltage	-0.3	+4.0	V	80 < F max +3.96 V
2	Input Voltage	-0.3	V _{CC} +0.3	V	
3	Output Current	-20	+20	mA	
4	Storage Temperature Range	-55	+125	°C	

6. Electrical Specifications

	Parameters	SYM	Electrical Spec.				Notes
			min	typ	max	Units	
1	Nominal Frequency	f _{nom}	6.5		160	MHz	*2
2	Supply Voltage	V _{CC}	+1.8 to +3.3			V	*3
3	Current Consumption (Operating)	I _{CC}	See Table.2			mA	at 25 °C
4	Current Consumption (Stand-by)	I _{ST}			20	μA	at 25 °C
5	Output Level	-	CMOS				
6	Load Capacitance	C _L			15	pF	
7	Operating Temperature Range	T _{opr}	[-10 to +60] to [-40 to +125]			°C	Table.1
8	Overall Frequency Tolerance	Δf/f _{nom}	± 20 to ± 100			ppm	Table.1 *1
9	Output Voltage	V _{OL}			0.1 V _{CC}	V	6.5 ≤ F ≤ 80
		V _{OH}	0.9 V _{CC}			V	
		V _{OL}			0.2 V _{CC}	V	80 < F ≤ 160
		V _{OH}	0.8 V _{CC}			V	
10	Rise Time(t _r), Fall Time(t _f)	t _r /t _f			5	ns	+2.5 V to +3.3 V 0.1 V _{CC} to 0.9 V _{CC}
					6	ns	+1.8 V 0.1 V _{CC} to 0.9 V _{CC}
					3	ns	80 < F ≤ 160 0.2 V _{CC} ~ 0.8 V _{CC}
11	Symmetry	SYM	45		55	%	at 1/2 V _{CC}
12	Start-up Time	t _{su}			4	ms	
13	Output Wave Form	-	Square wave				
14	Stand-by Function	#1 PAD input				# 3 PAD output	
		H level (0.7 V _{CC} to V _{CC}) or open				Operating	
		L level (0.3 V _{CC} max)				High impedance	

*1 Inclusive of Freq. tolerance (at 25 °C), frequency/temperature characteristics, frequency/voltage coefficient.

*2 Frequencies below 6.5MHz are also available, so please contact us if you are interested.

*3 Supply Voltage: +2.5 to +3.3 V (131 to 160 MHz)

Table.1 NDK Spec. No. List
6.5MHz \leq F \leq 60MHz

Overall Frequency Tolerance	Operating Temperature Range [°C]	Supply Voltage [V]			
		+1.8 \pm 0.18	+2.5 \pm 0.25	+3.0 \pm 0.3	+3.3 \pm 0.33
$\pm 100 \times 10^{-6}$	-40 to +125	NSC5019A	NSC5019B	NSC5019C	NSC5019D
$\pm 50 \times 10^{-6}$	-40 to +105	NSC5021A	NSC5021B	NSC5021C	NSC5021D
$\pm 50 \times 10^{-6}$	-40 to +85	NSC5022A	NSC5022B	NSC5022C	NSC5022D
$\pm 30 \times 10^{-6}$	-10 to +70	NSC5024A	NSC5024B	NSC5024C	NSC5024D
$\pm 20 \times 10^{-6}$	-10 to +60	NSC5025A	NSC5025B	NSC5025C	NSC5025D

60MHz < F \leq 80MHz

Overall Frequency Tolerance	Operating Temperature Range [°C]	Supply Voltage [V]			
		+1.8 \pm 0.18	+2.5 \pm 0.25	+3.0 \pm 0.3	+3.3 \pm 0.33
$\pm 100 \times 10^{-6}$	-40 to +125	NSC5430A	NSC5430B	NSC5430C	NSC5430D
$\pm 50 \times 10^{-6}$	-40 to +105	NSC5431A	NSC5431B	NSC5431C	NSC5431D
$\pm 50 \times 10^{-6}$	-40 to +85	NSC5432A	NSC5432B	NSC5432C	NSC5432D
$\pm 30 \times 10^{-6}$	-10 to +70	NSC5433A	NSC5433B	NSC5433C	NSC5433D
$\pm 20 \times 10^{-6}$	-10 to +60	NSC5434A	NSC5434B	NSC5434C	NSC5434D

80MHz < F \leq 160MHz

Overall Frequency Tolerance	Operating Temperature Range [°C]	Supply Voltage [V]			
		+1.8 \pm 0.18	+2.5 \pm 0.25	+3.0 \pm 0.3	+3.3 \pm 0.33
$\pm 100 \times 10^{-6}$	-40 to +125	NSC5452A	NSC5452B	NSC5452C	NSC5452D
$\pm 50 \times 10^{-6}$	-40 to +105	NSC5453A	NSC5453B	NSC5453C	NSC5453D
$\pm 50 \times 10^{-6}$	-40 to +85	NSC5454A	NSC5454B	NSC5454C	NSC5454D
$\pm 30 \times 10^{-6}$	-10 to +70	NSC5455A	NSC5455B	NSC5455C	NSC5455D
$\pm 20 \times 10^{-6}$	-10 to +60	NSC5456A	NSC5456B	NSC5456C	NSC5456D

Table.2 Current Consumption (Operating)

Nominal Frequency [MHz]	Current Consumption [mA]							
	6.5 \leq F < 10	10 \leq F < 20	20 \leq F < 30	30 \leq F < 40	40 \leq F < 50	50 \leq F < 60	60 \leq F < 70	70 \leq F \leq 80
1.8 V	2.5 MAX	3.5 MAX	4.0 MAX	4.5 MAX	5.0 MAX	5.5 MAX	6.0 MAX	6.5 MAX
2.5 V	3.0 MAX	4.0 MAX	4.5 MAX	5.0 MAX	5.5 MAX	6.0 MAX	6.5 MAX	7.5 MAX
3.0 V	3.5 MAX	4.5 MAX	5.0 MAX	5.5 MAX	6.0 MAX	6.5 MAX	7.5 MAX	8.5 MAX
3.3 V	3.5 MAX	4.5 MAX	5.0 MAX	5.5 MAX	6.0 MAX	7.0 MAX	8.0 MAX	9.0 MAX

Nominal Frequency [MHz]	Current Consumption [mA]			
	80 < F \leq 85	85 < F \leq 105	105 < F \leq 130	130 < F \leq 160
1.8 V	9.5 MAX	10.5 MAX	12.0 MAX	—
2.5 V	11.5 MAX	12.5 MAX	15.5 MAX	32.0 MAX
3.0 V	13.0 MAX	15.5 MAX	19.5 MAX	37.5 MAX
3.3 V	13.5 MAX	16.0 MAX	20.0 MAX	38.0 MAX

Table.3 Supported Frequency List

Nominal Frequency [MHz]						
12 MHz	27 MHz	48 MHz	125 MHz			
13.33 MHz	30 MHz	49.152 MHz	156.25 MHz			
18.432 MHz	31.5 MHz	50 MHz	160 MHz			
20 MHz	32 MHz	60 MHz				
22.5792 MHz	33.33 MHz	63.75 MHz				
24 MHz	33.3333 MHz	64 MHz				
24.576 MHz	40 MHz	74.25 MHz				
25 MHz	42 MHz	80 MHz				
26 MHz	45.1584 MHz	100 MHz				

Frequencies not listed in the list are also available, so please contact us if you have any request.

Output Voltage

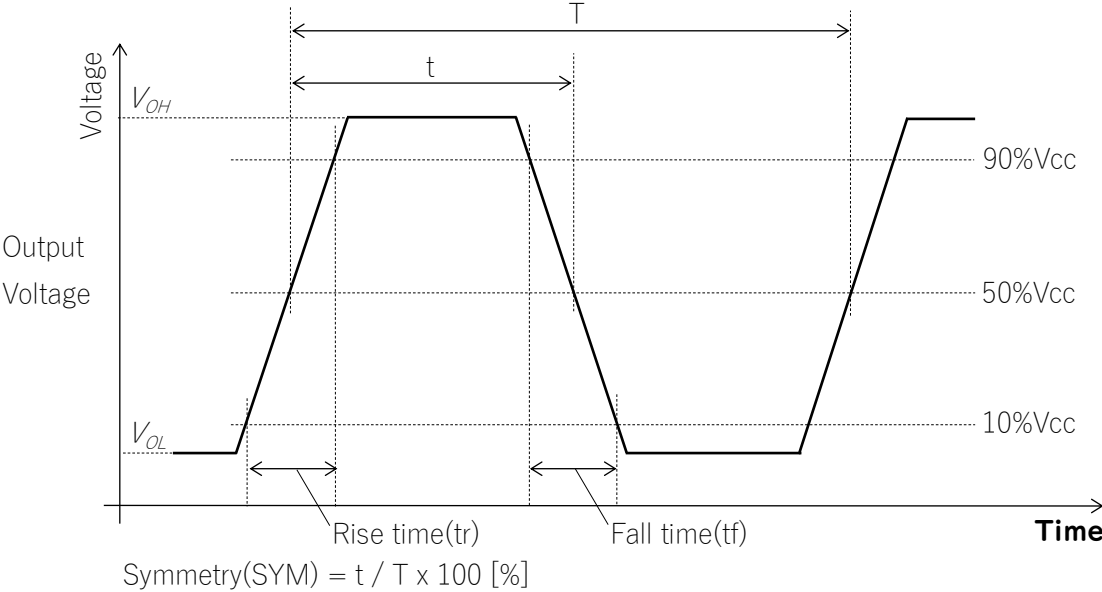

Start-up Time

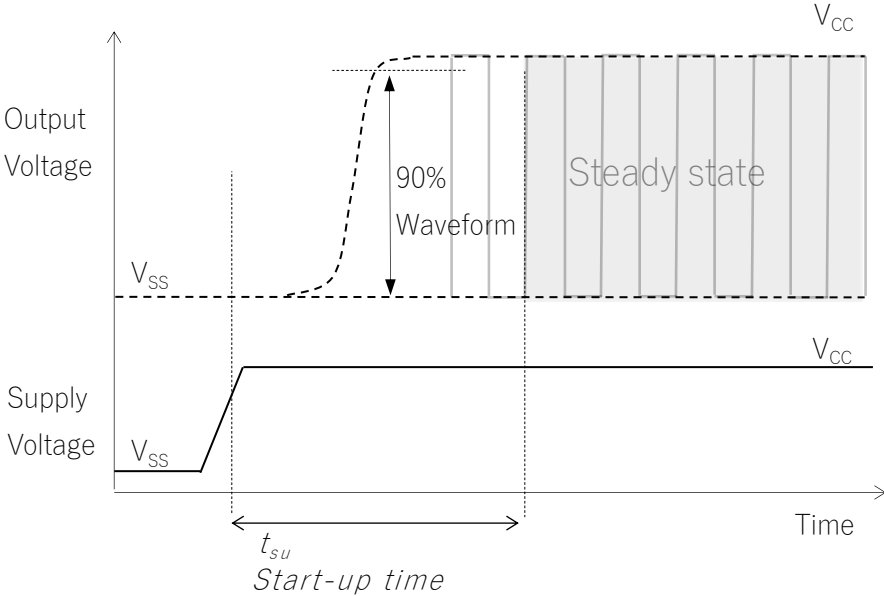

Measuring circuits

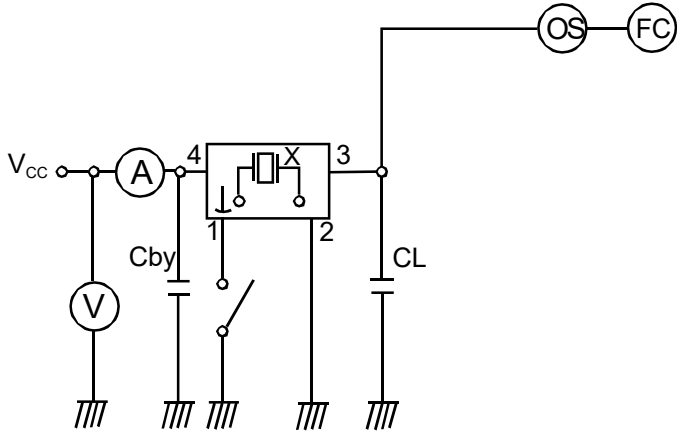

CL ; 15pF MAX including input capacity of oscilloscope
Cby ; Bypass capacitor (0.01uF)

7. Prohibited items

Example For Soldering Conditions (The below graph corresponds to Pb free solder)

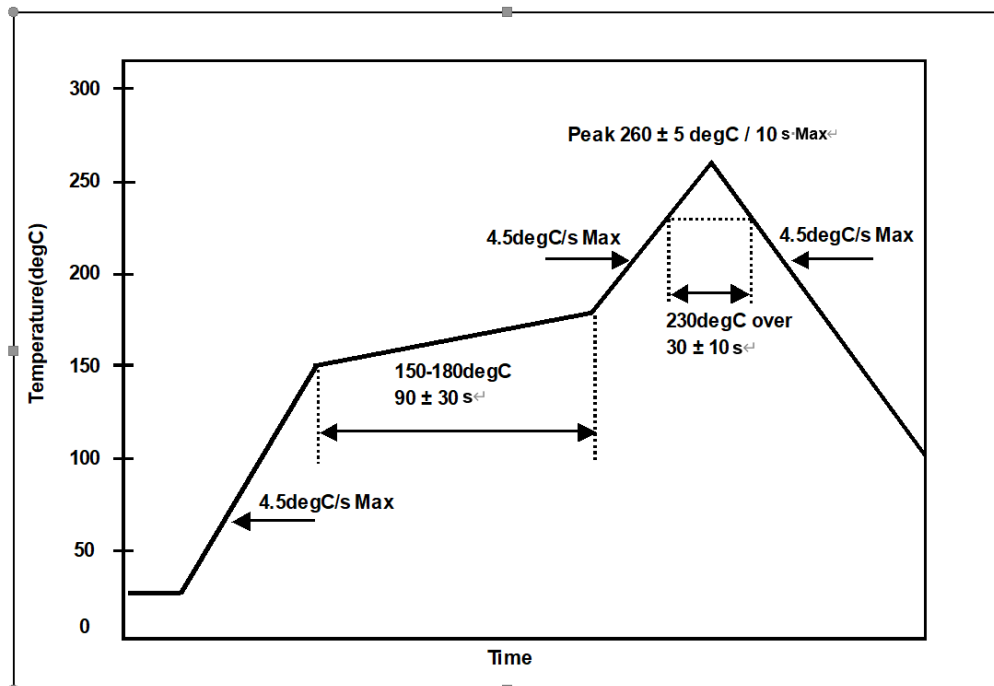

Be sure to use the product under the following conditions. Otherwise, the characteristics deterioration or destruction of the product may result.

- (1) Reflow soldering heat resistance
 - Peak temperature: 265 ° C, 10 s
 - Heating: 230 ° C or higher, 40 s
 - Preheating: 150 ° C to 180 ° C, 120 s
 - Reflow passage times: 3 times
- (2) Manual soldering heat resistance
 - Pressing a soldering iron of 350 ° C on the terminal electrode for 3 s.

8. Electrostatic Discharge

MM: 200 V
HBM: 2000 V
CDM: 500 V

9. MSL (Moisture Sensitivity Level)

This products MSL is 1.

Dimension of External

Unit : mm

Tolerance : ± 0.1 mm

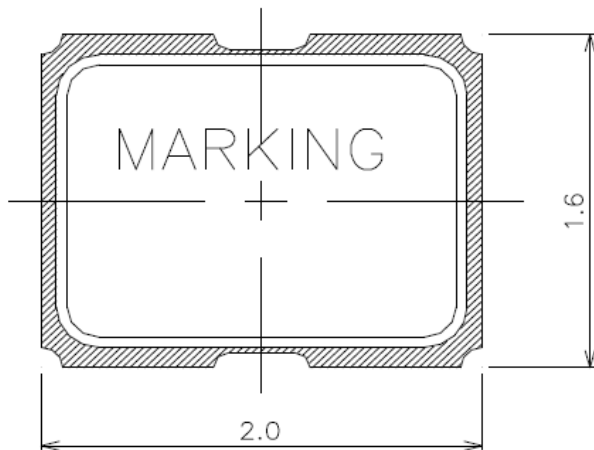

Terminal land connections

#1	STAND-BY
#2	GND
#3	OUTPUT
#4	Vcc

Unit:mm

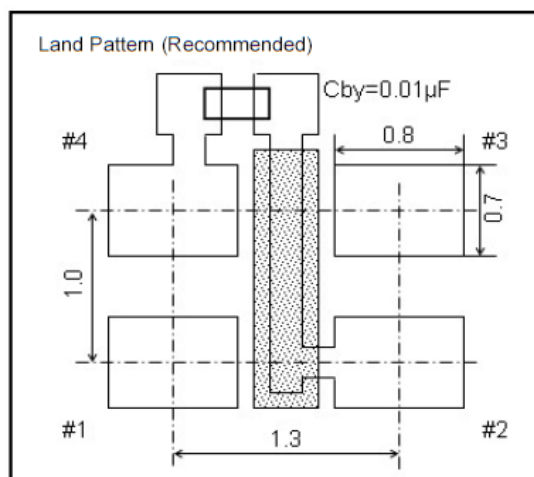
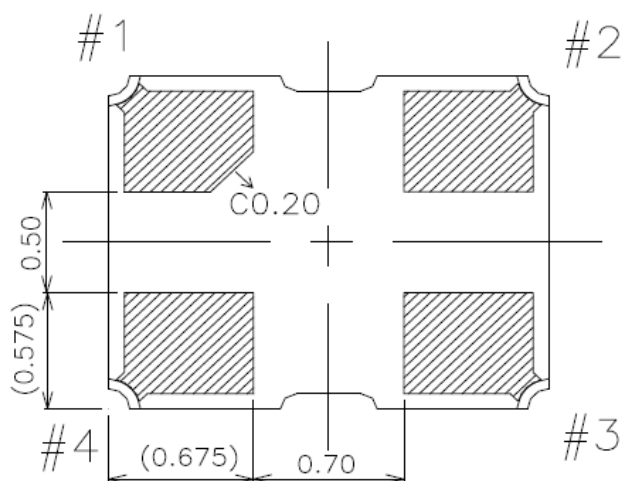
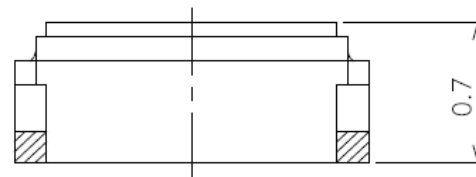
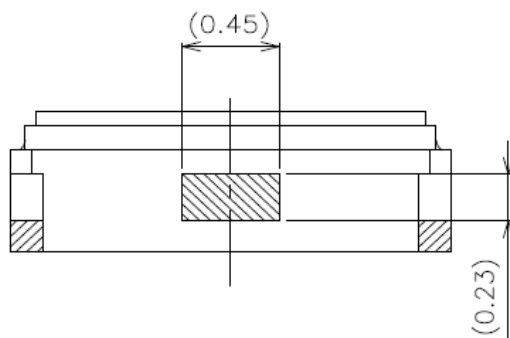

■ Taping and Reel Spec.

Unit : mm

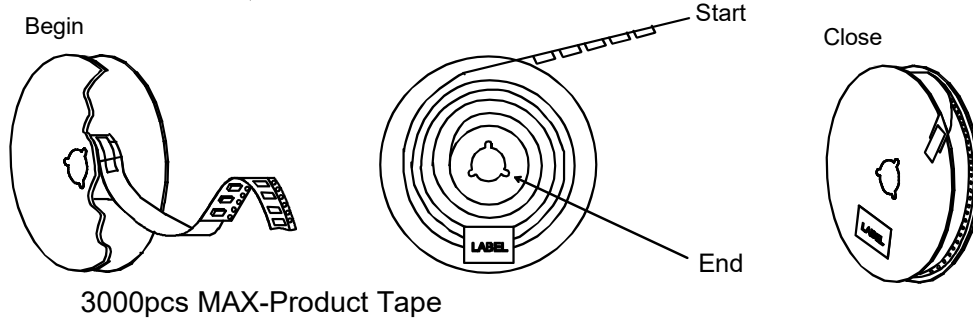
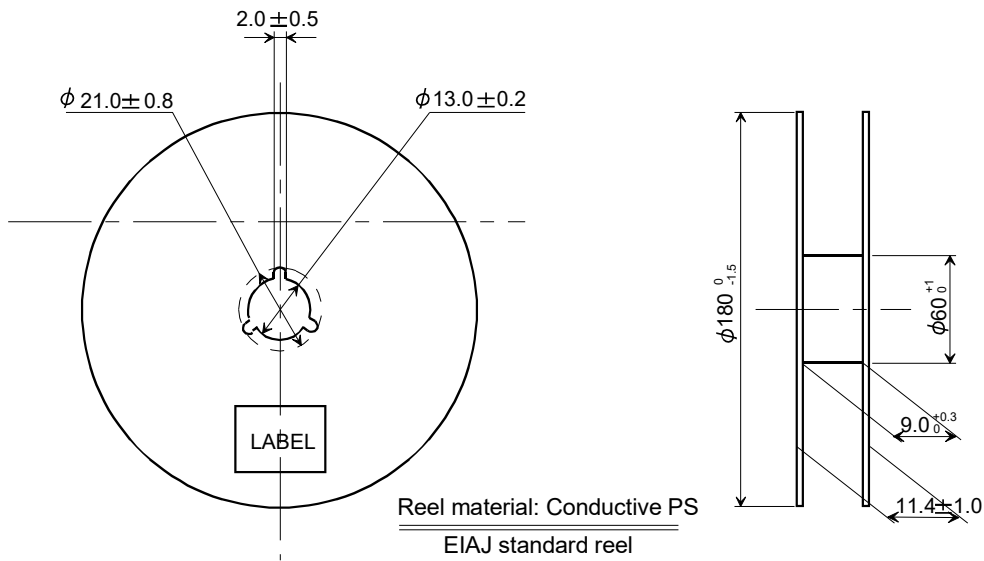
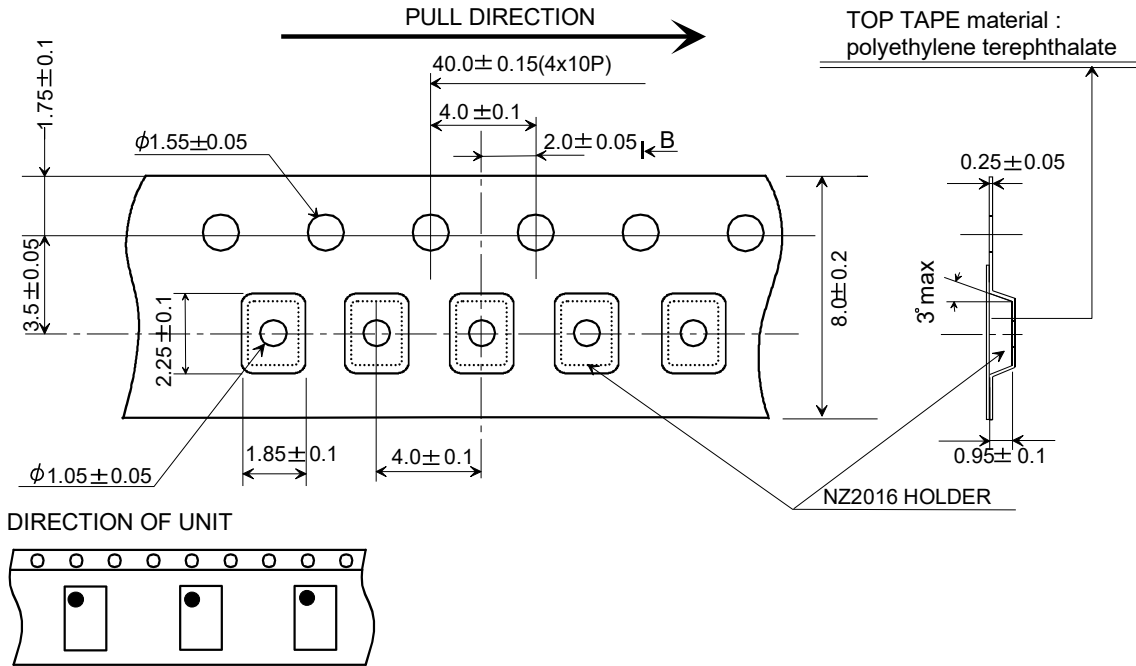

■ Marking

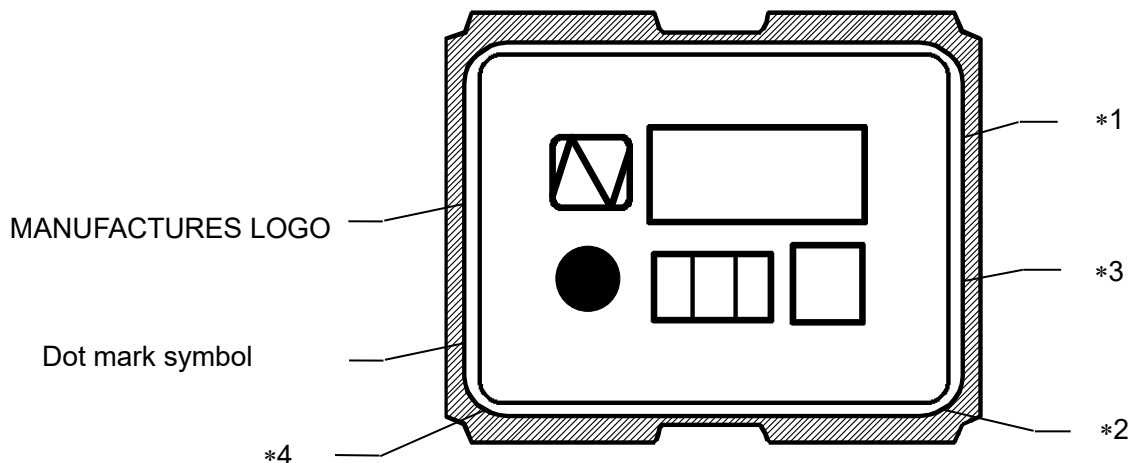

*1 [FREQUENCY]

Digits are four and 5TH digit will be omitted.
 MHz unit sign is not marked.
 ex,) 28.63636MHz → 28.63 [Unit sign not marked]

*2[Lot Code(Digits are Two)]

a:First digit:lower one digit of year.
 ex) 2008 →8 , 2009 → 9

b:Second digit:Month No.(See table)

Month	Jan	Feb	Mar	Apr	May	Jun	Jul	Aug	Sep	Oct	Nov	Dec
Month No.	1	2	3	4	5	6	7	8	9	X	Y	Z

*3 [Trace code]

Trace code consists of four digits number or letter.
 This code indicates production date and production line number.

*4 [Model Symbol]
 See right table.

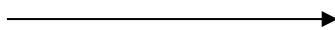

[MODEL MARK]		
NZ2016SD	→	D
NZ2016SDA	→	D
NZ2016SE	→	E
NZ2016SEB	→	E
NZ2016SF	→	F
NZ2016SFA	→	F
NZ2016SG	→	G
NZ2016SH	→	H
NZ2016SHA	→	H
NZ2016SJ	→	J
NZ2016SN	→	N

■ Data

- Phase jitter

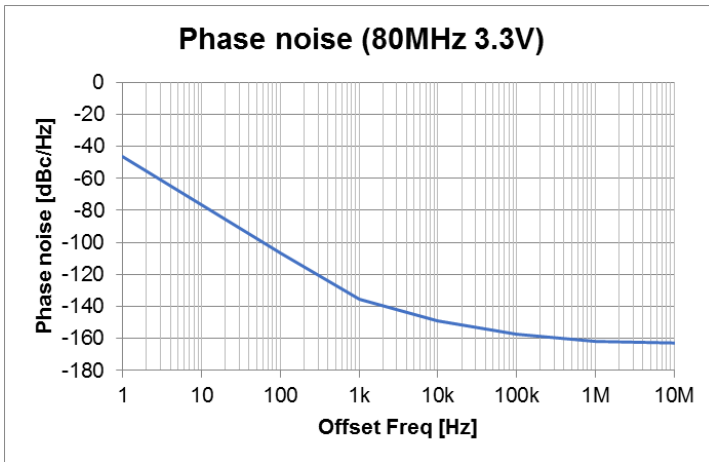

- Phase jitter : Typ. 100 fs (Frequency Offset: 12 kHz to 20 MHz) @80 MHz, 3.3 V

Instruction Notice

1 Noise

When using this product, please insert a bypass capacitor between the power supply and GND.
(Closer to the product terminal is desirable.)

The bypass capacitor values shown in our specifications and drawings are for reference only.
(They are not guaranteed values.)

In actual use, please select the appropriate bypass capacitor value for your circuit.

NDK shall not be liable for any and all events resulting from or in connection with the use of this product in a manner that does not comply with the above instruction.

2 Resistance to dropping

The NZ2016S series is designed to be impactproof so that no damage occurs when dropped a height (75 cm) three times. However, if dropped from a desk etc., it is advisable to check their performance or contact us to check it.

3 Electrostatic protection

The NZ2016S series employ C-MOS ICs for the active element. Please use them in static-free environments.

4 Cleaning

Basically, the NZ2016S series are applicable for ultrasonic wave cleaning. However, in some case, during ultrasonic wave cleanings, internal design may get damage. Please check condition carefully beforehand.

5 Other

The NZ2016S series are C-MOS applied products. And careful handling (same as with C-MOS IC) are needed to avoid electrostatic problems.

Incorrect PAD connection is cause of trouble. Please make sure to connect correctly as below.

#2 terminal → GND

#4 terminal → V_{CC}

Notes On Use

1 Even if the appearance color etc. of the product differs by purchasing the component parts by more than two companies, there is no influence on the characteristics and reliability.

2 IN THE CASE OF THE FOLLOWING ITEMS, WE ARE NOT RESPONSIBLE FOR WARRANTY / COMPENSATION.

(1) WHEN PRODUCTS OF THIS SPECIFICATION ARE USED FOR EQUIPMENT RELATED TO HUMAN LIFE OR PROPERTY, IT IS THE RESPONSIBILITY OF THE CUSTOMER TO CONFIRM THE INFLUENCE ON THIS PRODUCT AND EQUIPMENT TO BE USED BEFOREHAND, CONDUCT NECESSARY SAFETY DESIGN (INCLUDING REDUNDANT DESIGN, MALFUNCTION PREVENTION DESIGN, etc.), PLEASE USE IT AFTER SECURING SUFFICIENT SAFETY OF EQUIPMENT.

1.SAFETY-RELATED EQUIPMENT SUCH AS AUTOMOBILES, TRAINS, SHIPS, etc., OR EQUIPMENT DIRECTLY INVOLVED IN OPERATION

2.AIRCRAFT EQUIPMENT

3.SPACE EQUIPMENT

4.MEDICAL EQUIPMENT

5.MILITARY EQUIPMENT

6.DISASTER PREVENTION / CRIME PREVENTION EQUIPMENT

7.TRAFFIC LIGHT

8.OTHER EQUIPMENT REQUIRING THE SAME PERFORMANCE AS THE ABOVE-MENTIONED EQUIPMENT

(2) IN CASES WHERE IT IS NOT INDICATED IN THE REQUESTED STANDARD AND IS USED UNDER CONDITIONS OF USE (INCLUDING CIRCUIT MARGIN etc.) THAT CAN NOT BE PREDICTED AT THE PRODUCTION STAGE.

(3) WHEN USING ULTRASONIC WELDING MACHINE.(THERE IS A POSSIBILITY THAT THE CHARACTERISTIC DEGRADATION IS CAUSED BY THE RESONANCE PHENOMENON OF THE PIEZOELECTRIC MATERIAL.(EXAMPLE;CRYSTAL PIECE))

WE WILL NOT TAKE ANY RESPONSIBILITY FOR THE INFLUENCE OF THE CUSTOMERS' PROCESS.

SO, PLEASE SUFFICIENTLY EVALUATE AT A SAMPLE STEP WHEN YOU USE ULTRASONIC WELDING MACHINE.

- (4) USING RESIN MOLD MAY AFFECT THE PRODUCT CHARACTERISTIC.
PLEASE MAKE SURE TO TELL OUR SALES CONTACT WHEN YOU USE RESIN MOLD. WE WILL PERFORM INDIVIDUAL CORRESPONDENCE ABOUT A DELIVERY SPECIFICATION AND A EVALUATION METHOD.
IN ADDITION, IF YOU USE RESIN MOLD WITHOUT CONTACTING US, AND CAUSES DAMAGES AGAINST A CUSTOMER OR A THIRD PARTY, WE WILL NOT BE LIABLE FOR THE DAMAGES AND OTHER RESPONSIBILITIES BECAUSE WE CONSIDER IT IS UNDER SELF-RESPONSIBILITY USING RESIN MOLD.
WE WILL NOT TAKE ANY RESPONSIBILITY FOR THE INFLUENCE OF THE CUSTOMERS' PROCESS. PLEASE EFFICIENTLY EVALUATE AT A SAMPLE STEP WHEN YOU USE RESIN MOLD.
- (5) WHEN PERFORMING IMPROPER HANDLING THAT EXCEEDS THE GUARANTEED RANGE.
- 3 This product can not be used for equipment related to the safety of automobiles or equipment directly involved in operation.(example: air bag, TPMS, engine control, steering control, brake control etc.)

Notes on storage

- 1 When storing the product in high temperature and high humidity condition for a long time, product characteristics (solderability etc.) and packaging condition may be deteriorated. Please store product at temperature + 5 ° C to + 35 ° C, humidity 85 % RH or less. The product is an electronic component, so please do not storage and use, under a dewing state.
- 2 The product storage deadline is 12 months after delivery in unopened state. Please use within storage deadline. If you exceed storage deadline, please check the product characteristics etc, please use.

Handling of this document and other requests

Please refer to the " Site Guidance" on our website for the handling of information contained in this document. (<https://www.ndk.com/en/terms/>)