

Description

The AH332XQ is an AEC-Q100 qualified high-voltage Hall-effect unipolar switch IC designed for position and proximity sensing in automotive applications such as in seat and seatbelt buckle, steering lock/immobilization, gear stick, transmission actuator and gear position, HVAC compression, wiper, door/trunk closure, etc. To support a wide range of the demanding applications, the design has been optimized to operate over the supply range of 3.0V to 28V. With chopper stabilized architecture and an internal bandgap regulator to provide temperature compensated supply for internal circuits, the AH332XQ provides a reliable solution over the whole operating range. For robustness and protection, the device has a reverse blocking diode with a zener clamp on the supply. The output has an overcurrent limit and a zener clamp.

The single open-drain output can be switched on with South pole of sufficient strength. When the magnetic flux density (B) perpendicular to the package is larger than the operate point (B_{OP}) the output is switched on (pulled low) and is held on until the magnetic flux density B is lower than the release point (B_{RP}).

The magnetic operating and release polarity is opposite for SOT23 (Type S) and SC59 packages. The SOT23 (Type S), SIP-3 (Ammo Pack), and SIP-3 (Bulk Pack) packages require south pole to the part marking side to operate while SC59 requires south pole to the non-part marking side.

Features

- Unipolar Operation
- High Sensitivity: B_{OP} and B_{RP} of 30G to 275G and 20G to 250G Typical
- Single Open-Drain Output with Overcurrent Limit
- 3.0V to 28V Operating Voltage Range
- 40V Load Dump Protection
- Resistant to Physical Stress
- Chopper Stabilized Design Provides
 - Superior Temperature Stability
 - Minimal Switch Point Drift
 - Enhanced Immunity to Stress
- Good RF Noise Immunity
- Reverse Blocking Diode
- Zener Clamp on Supply and Output Pins
- -40°C to +150°C Operating Temperature
- High ESD HBM: 8kV, CDM: 1kV
- AEC-Q100 Grade 0 Qualified
- Industry Standard SC59, SOT23 (Type S), SIP-3 (Ammo Pack) and SIP-3 (Bulk Pack) Packages
- **Totally Lead-Free & Fully RoHS Compliant (Notes 1 & 2)**
- **Halogen and Antimony Free. "Green" Device (Note 3)**
- **The AH332XQ is suitable for automotive applications requiring specific change control; this part is AEC-Q100 qualified, PPAP capable, and manufactured in IATF 16949 certified facilities.**

<https://www.diodes.com/quality/product-definitions/>

- Notes:
1. No purposely added lead. Fully EU Directive 2002/95/EC (RoHS), 2011/65/EU (RoHS 2) & 2015/863/EU (RoHS 3) compliant.
 2. See <https://www.diodes.com/quality/lead-free/> for more information about Diodes Incorporated's definitions of Halogen- and Antimony-free, "Green" and Lead-free.
 3. Halogen- and Antimony-free "Green" products are defined as those which contain <900ppm bromine, <900ppm chlorine (<1500ppm total Br + Cl) and <1000ppm antimony compounds.

Pin Assignments

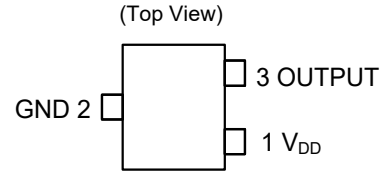

SC59 and SOT23 (Type S)

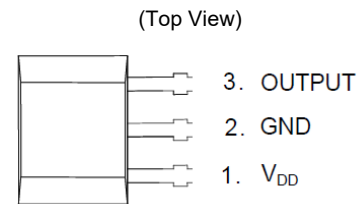

SIP-3 (Ammo Pack) and SIP-3 (Bulk Pack)

Applications

- Position and proximity sensing in automotive applications
- Seat positions
- Seatbelt buckles
- Steering locks/immobilization
- Gear sticks
- HVAC compression
- Transmission actuators
- Transmission gear positions
- Wipers
- Sunroofs and windows
- Door/trunk closures
- Door locks
- Contactless switches

Typical Applications Circuit

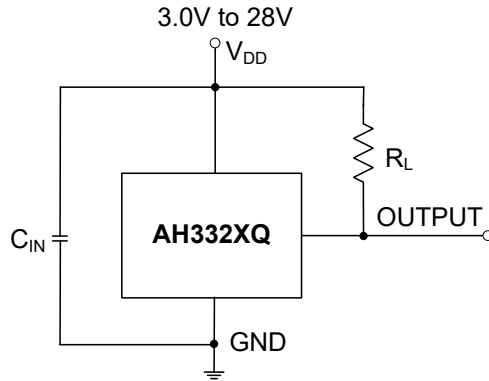

Note: 4. C_{IN} is for power stabilization and to strengthen the noise immunity. The recommended capacitance is 10nF to 100nF. R_L is the pullup resistor.

Pin Descriptions

Packages: SC59, SOT23 (Type S), SIP-3 (Ammo Pack) and SIP-3 (Bulk Pack)

Pin Number	Pin Name	Function
1	V _{DD}	Power Supply Input
2	GND	Ground
3	OUTPUT	Output Pin

Functional Block Diagram

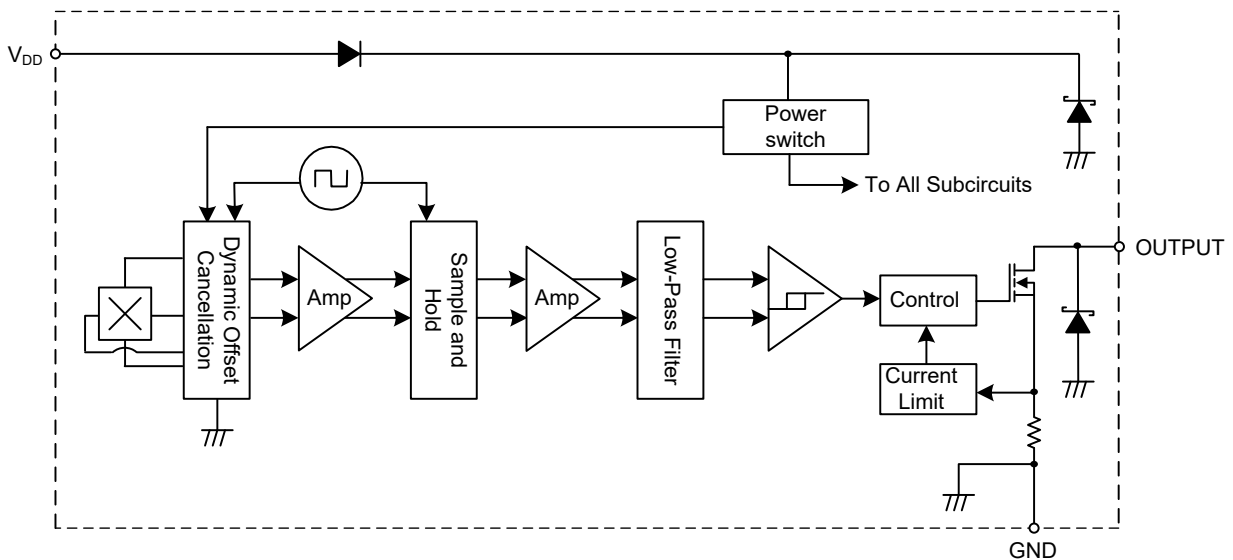

Absolute Maximum Ratings (Notes 5 & 6) (@T_A = +25°C, unless otherwise specified.)

Symbol	Characteristic	Value	Unit	
V _{DD}	Supply Voltage (Note 6)	40	V	
V _{DDR}	Reverse Supply Voltage	-18	V	
V _{OUT_MAX}	Output Pin Off Voltage (Note 6)	32	V	
I _{OUT}	Continuous Output Current	60	mA	
I _{OUT_R}	Reverse Output Current	-50	mA	
B	Magnetic Flux Density	Unlimited		
P _D	Package Power Dissipation	SIP-3 (Ammo Pack)	mW	
		SIP-3 (Bulk Pack)		550
		SC59 and SOT23 (Type S)		230
T _S	Storage Temperature Range	-65 to +165	°C	
T _J	Maximum Junction Temperature	+170	°C	
ESD HBM	Electrostatic Discharge Withstand Capability—Human Body Model	8	kV	
ESD CDM	Electrostatic Discharge Withstand Capability—Charged Device Model	1	kV	

- Notes:
- Stresses greater than those listed under *Absolute Maximum Ratings* can cause permanent damage to the device. These are stress ratings only, and functional operation of the device at these or any other conditions beyond those indicated under *Recommended Operating Conditions* is not implied. Exposure to *Absolute Maximum Ratings* for extended periods can affect device reliability.
 - The absolute maximum V_{DD} of 40V is a transient stress rating and is not meant as a functional operating condition. It is not recommended to operate the device at the absolute maximum-rated conditions for over 100ms.

Recommended Operating Conditions (@T_A = -40°C to +150°C, unless otherwise specified.)

Symbol	Parameter	Conditions	Rating	Unit
V _{DD}	Supply Voltage	Supply voltage, between V _{DD} and GND pins	3.0 to 28	V
T _A	Operating Temperature Range	Operating ambient temperature range	-40 to +150	°C

Electrical Characteristics (Notes 7 & 8) (@T_A = -40°C to +150°C, V_{DD} = 3V to 28V, unless otherwise specified.)

Symbol	Parameter	Conditions	Min	Typ	Max	Unit
V _{OUT_ON}	Output On Voltage	I _{OUT} = 20mA, B > B _{OP}	—	0.2	0.4	V
I _{OUT_OFF}	Output Leakage Current (When Output Is Off)	V _{OUT} = 28V, B < B _{RP} , output off	—	< 0.1	10	μA
I _{DD}	Supply Current	Output open, T _A = +25°C	—	3	4	mA
		Output open, T _A = -40°C to +150°C	—	—	5	mA
I _{DD_R}	Reverse Supply Current	V _{DD} = -18V, T _A = +25°C	—	0.001	—	mA
		V _{DD} = -18V, T _A = -40°C to +150°C	—	0.001	2.3	mA
t _{P_ON}	Device Power-On Time (Startup Time)	V _{DD} ≥ 3V, B > B _{OP} (Note 7)	—	10	—	μs
f _C	Chopping Frequency	V _{DD} ≥ 3V (Note 9)	—	500	—	kHz
t _D	Response Time Delay (Time from Magnetic Threshold Reached to the Start of the Output Rise or Fall)	(Note 9)	—	4	—	μs
t _R	Output Rising Time (External Pullup Resistor R _L and Load Capacitance Dependent)	R _L = 1kΩ, C _L = 20pF (Note 9)	—	0.2	1	μs
t _F	Output Falling Time (Internal Switch Resistance and Load Capacitance Dependent)	R _L = 1kΩ, C _L = 20pF (Note 9)	—	0.1	1	μs
I _{OCL}	Output Current Limit	B > B _{OP} (Note 10)	30	—	55	mA
V _Z	Zener Clamp Voltage	I _{DD} = 5mA, T _A = +25°C	28	—	—	V

- Notes:
- When power is initially turned on, V_{DD} must be within its correct operating range (3.0V to 28V) to guarantee the output sampling. The output state is valid after the startup time of 10μs typical from the operating voltage reaching 3V.
 - Typical values are defined at T_A = +25°C, V_{DD} = 12V. Maximum and minimum values over the operating temperature range is not tested in production but guaranteed by design, process control and characterization.
 - Guaranteed by design, process control, and characterization. Not tested in production.
 - The device limits the output current I_{OUT} to current limit of I_{OCL}.

Magnetic Characteristics (Notes 11 & 12) ($T_A = -40^{\circ}\text{C}$ to $+150^{\circ}\text{C}$, $V_{DD} = 3.0\text{V}$ to 28V , unless otherwise specified)

Part Number	Symbol	Parameter	Min	Typ	Max	Unit	Output Type
AH3322Q	B _{OPS} (South pole to the part marking side for SOT23 (Type S) and SIP-3 (Ammo Pack), SIP-3 (Bulk Pack) packages; South pole to the non-part marking side for SC59 package. See diagram below)	Operation Point	15	30	45	Gauss	Open-Drain
	B _{RPS} (South pole to the part marking side for SOT23 (Type S) and SIP-3 (Ammo Pack), SIP-3 (Bulk Pack) packages; South pole to the non-part marking side for SC59 package. See diagram below)	Release Point	5	20	35		
	B _{HY} (B _{OPX} - B _{RPX})	Hysteresis (Note 13)	5	10	17		
AH3323Q	B _{OPS} (South pole to the part marking side for SOT23 (Type S) and SIP-3 (Ammo Pack), SIP-3 (Bulk Pack) packages; South pole to the non-part marking side for SC59 package. See diagram below)	Operation Point	38	55	72	Gauss	Open-Drain
	B _{RPS} (South pole to the part marking side for SOT23 (Type S) and SIP-3 (Ammo Pack), SIP-3 (Bulk Pack) packages; South pole to the non-part marking side for SC59 package. See diagram below)	Release Point	20	35	50		
	B _{HY} (B _{OPX} - B _{RPX})	Hysteresis (Note 13)	12	20	28		
AH3324Q	B _{OPS} (South pole to the part marking side of SOT23 (Type S) and SIP-3 (Ammo Pack), SIP-3 (Bulk Pack) packages)	Operation Point	60	80	100	Gauss	Open-Drain
	B _{RPS} (South pole to the part marking side of SOT23 (Type S) and SIP-3 (Ammo Pack), SIP-3 (Bulk Pack) packages)	Release Point	40	60	80		
	B _{HY} (B _{OPX} - B _{RPX})	Hysteresis (Note 13)	14	20	29		
AH3325Q	B _{OPS} (South pole to the part marking side of SOT23 (Type S) and SIP-3 (Ammo Pack), SIP-3 (Bulk Pack) packages)	Operation Point	80	100	120	Gauss	Open-Drain
	B _{RPS} (South pole to the part marking side of SOT23 (Type S) and SIP-3 (Ammo Pack), SIP-3 (Bulk Pack) packages)	Release Point	60	80	100		
	B _{HY} (B _{OPX} - B _{RPX})	Hysteresis (Note 13)	15	20	31		

- Notes:
- When power is initially turned on, V_{DD} must be within its correct operating range (3.0V to 28V) to guarantee the output sampling. The output state is valid after the startup time of 10 μs typical from the operating voltage reaching 3V.
 - Typical values are defined at $T_A = +25^{\circ}\text{C}$, $V_{DD} = 12\text{V}$. Maximum and minimum values over the operating temperature range is not tested in production but guaranteed by design, process control, and characterization.
 - Maximum and minimum hysteresis is guaranteed by design, process control, and characterization.

Magnetic Characteristics (Notes 11 & 12) ($T_A = -40^{\circ}\text{C}$ to $+150^{\circ}\text{C}$, $V_{DD} = 3.0\text{V}$ to 28V , unless otherwise specified) (continued)

Part Number	Symbol	Parameter	Min	Typ	Max	Unit	Output Type
AH3326Q	B _{OPS} (South pole to the part marking side for SOT23 (Type S) and SIP-3 (Ammo Pack), SIP-3 (Bulk Pack) packages; South pole to the non-part marking side for SC59 package. See diagram below)	Operation Point	65	100	135	Gauss	Open-Drain
	B _{RPS} (South pole to the part marking side for SOT23 (Type S) and SIP-3 (Ammo Pack), SIP-3 (Bulk Pack) packages; South pole to the non-part marking side for SC59 package. See diagram below)	Release Point	50	85	120		
	B _{HY} (B _{OPX} - B _{RPX})	Hysteresis (Note 13)	8	15	25		
AH3327Q	B _{OPS} (South pole to the part marking side for SOT23 (Type S) and SIP-3 (Ammo Pack), SIP-3 (Bulk Pack) packages; South pole to the non-part marking side for SC59 package. See diagram below)	Operation Point	95	115	140	Gauss	Open-Drain
	B _{RPS} (South pole to the part marking side for SOT23 (Type S) and SIP-3 (Ammo Pack), SIP-3 (Bulk Pack) packages; South pole to the non-part marking side for SC59 package. See diagram below)	Release Point	70	90	120		
	B _{HY} (B _{OPX} - B _{RPX})	Hysteresis (Note 13)	18	25	36		
AH3328Q	B _{OPS} (South pole to the part marking side of SOT23 (Type S) and SIP-3 (Ammo Pack), SIP-3 (Bulk Pack) packages)	Operation Point	130	150	180	Gauss	Open-Drain
	B _{RPS} (South pole to the part marking side of SOT23 (Type S) and SIP-3 (Ammo Pack), SIP-3 (Bulk Pack) packages)	Release Point	105	125	160		
	B _{HY} (B _{OPX} - B _{RPX})	Hysteresis (Note 13)	16	25	33		
AH3329Q	B _{OPS} (South Pole to the part marking side of SOT23 (Type S) and SIP-3 (Ammo Pack), SIP-3 (Bulk Pack) packages)	Operation Point	150	175	200	Gauss	Open-Drain
	B _{RPS} (South pole to the part marking side of SOT23 (Type S) and SIP-3 (Ammo Pack), SIP-3 (Bulk Pack) packages)	Release Point	125	150	180		
	B _{HY} (B _{OPX} - B _{RPX})	Hysteresis (Note 13)	18	25	35		

- Notes:
11. When power is initially turned on, V_{DD} must be within its correct operating range (3.0V to 28V) to guarantee the output sampling. The output state is valid after the startup time of 10 μs typical from the operating voltage reaching 3V.
 12. Typical values are defined at $T_A = +25^{\circ}\text{C}$, $V_{DD} = 12\text{V}$. Maximum and minimum values over the operating temperature range is not tested in production but guaranteed by design, process control, and characterization.
 13. Maximum and minimum hysteresis is guaranteed by design, process control, and characterization.

Magnetic Characteristics (Notes 11 & 12) ($T_A = -40^{\circ}\text{C}$ to $+150^{\circ}\text{C}$, $V_{DD} = 3.0\text{V}$ to 28V , unless otherwise specified) (continued)

Part Number	Symbol	Parameter	Min	Typ	Max	Unit	Output Type
AH3320Q	B _{OPS} (South pole to the part marking side for SOT23 (Type S) and SIP-3 (Ammo Pack), SIP-3 (Bulk Pack) packages; South pole to the non-part marking side for SC59 package. See diagram below)	Operation Point	180	210	240	Gauss	Open-Drain
	B _{RPS} (South pole to the part marking side for SOT23 (Type S) and SIP-3 (Ammo Pack), SIP-3 (Bulk Pack) packages; South pole to the non-part marking side for SC59 package. See diagram below)	Release Point	155	185	220		
	B _{HY} (B _{OPX} - B _{RPX})	Hysteresis (Note 13)	17	25	35		
AH3321Q	B _{OPS} (South pole to the part marking side of SOT23 (Type S) and SIP-3 (Ammo Pack), SIP-3 (Bulk Pack) packages)	Operation Point	235	275	300	Gauss	Open-Drain
	B _{RPS} (South pole to the part marking side of SOT23 (Type S) and SIP-3 (Ammo Pack), SIP-3 (Bulk Pack) packages)	Release Point	210	250	275		
	B _{HY} (B _{OPX} - B _{RPX})	Hysteresis (Note 13)	17	25	36		

- Notes:
- When power is initially turned on, V_{DD} must be within its correct operating range (3.0V to 28V) to guarantee the output sampling. The output state is valid after the startup time of 10 μs typical from the operating voltage reaching 3V.
 - Typical values are defined at $T_A = +25^{\circ}\text{C}$, $V_{DD} = 12\text{V}$. Maximum and minimum values over the operating temperature range is not tested in production but guaranteed by design, process control, and characterization.
 - Maximum and minimum hysteresis is guaranteed by design, process control, and characterization.

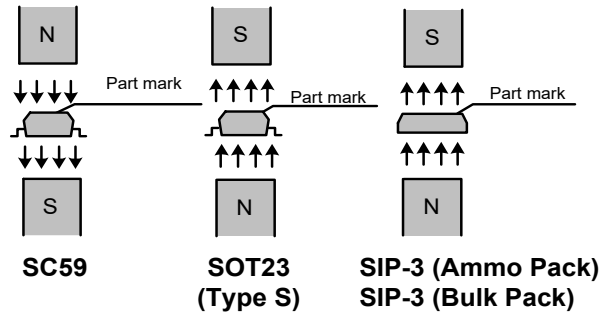
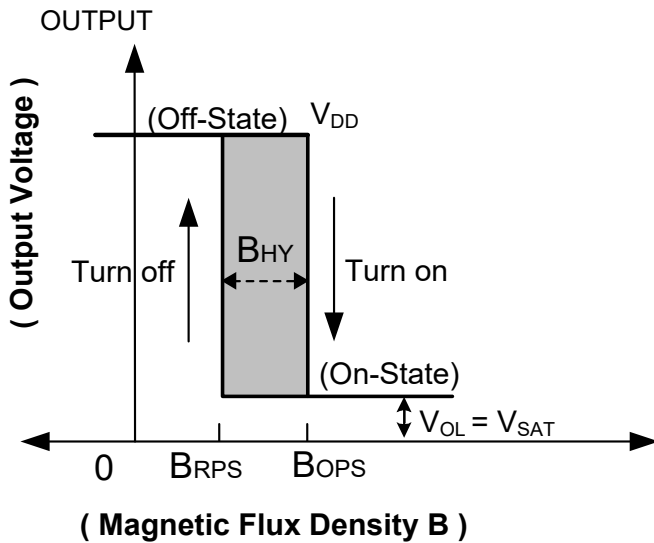

Thermal Performance Characteristics

(1) Package Types: SC59 and SOT23 (Type S)

T _A (°C)	25	50	60	70	80	85	90	100	105	110	120	125	130	140	150
P _D (mW)	230	184	166	147	129	120	110	92	83	74	55	46	37	18	0

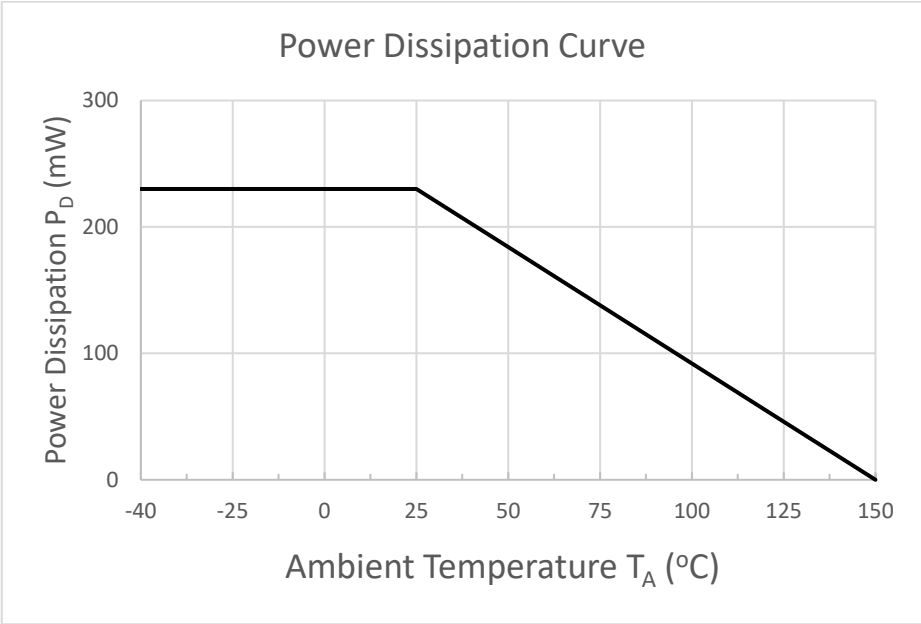

(2) Package Types: SIP-3 (Ammo Pack) and SIP-3 (Bulk Pack)

T _A (°C)	25	50	60	70	80	85	90	100	105	110	120	125	130	140	150
P _D (mW)	550	440	396	362	308	286	264	220	198	176	132	110	88	44	0

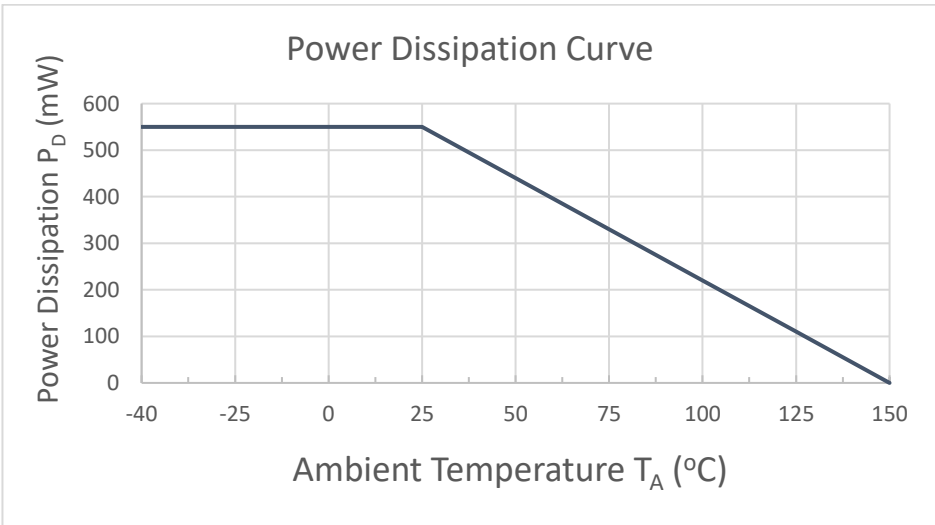

Ordering Information

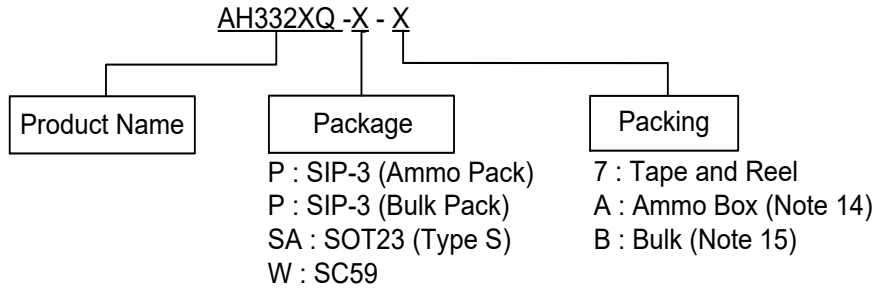

Orderable Part Number	Package Code	Package (Note 16)	Part Number Suffix	Packing	
				Qty.	Carrier
AH3322Q-P-A	P	SIP-3 (Ammo Pack)	-A	4,000	Ammo Box
AH3322Q-P-B	P	SIP-3 (Bulk Pack)	-B	1,000	Bulk
AH3322Q-SA-7	SA	SOT23 (Type S)	-7	3,000	7" Tape & Reel
AH3322Q-W-7	W	SC59	-7	3,000	7" Tape & Reel
AH3323Q-P-A	P	SIP-3 (Ammo Pack)	-A	4,000	Ammo Box
AH3323Q-P-B	P	SIP-3 (Bulk Pack)	-B	1,000	Bulk
AH3323Q-SA-7	SA	SOT23 (Type S)	-7	3,000	7" Tape & Reel
AH3323Q-W-7	W	SC59	-7	3,000	7" Tape & Reel
AH3324Q-P-B	P	SIP-3 (Bulk Pack)	-B	1,000	Bulk
AH3324Q-SA-7	SA	SOT23 (Type S)	-7	3,000	7" Tape & Reel
AH3325Q-P-B	P	SIP-3 (Bulk Pack)	-B	1,000	Bulk
AH3325Q-SA-7	SA	SOT23 (Type S)	-7	3,000	7" Tape & Reel
AH3326Q-P-A	P	SIP-3 (Ammo Pack)	-A	4,000	Ammo Box
AH3326Q-P-B	P	SIP-3 (Bulk Pack)	-B	1,000	Bulk
AH3326Q-SA-7	SA	SOT23 (Type S)	-7	3,000	7" Tape & Reel
AH3326Q-W-7	W	SC59	-7	3,000	7" Tape & Reel
AH3327Q-P-A	P	SIP-3 (Ammo Pack)	-A	4,000	Ammo Box
AH3327Q-P-B	P	SIP-3 (Bulk Pack)	-B	1,000	Bulk
AH3327Q-SA-7	SA	SOT23 (Type S)	-7	3,000	7" Tape & Reel
AH3327Q-W-7	W	SC59	-7	3,000	7" Tape & Reel
AH3328Q-P-A	P	SIP-3 (Ammo Pack)	-A	4,000	Ammo Box
AH3328Q-P-B	P	SIP-3 (Bulk Pack)	-B	1,000	Bulk
AH3328Q-SA-7	SA	SOT23 (Type S)	-7	3,000	7" Tape & Reel
AH3329Q-P-B	P	SIP-3 (Bulk Pack)	-B	1,000	Bulk
AH3329Q-SA-7	SA	SOT23 (Type S)	-7	3,000	7" Tape & Reel
AH3320Q-P-B	P	SIP-3 (Bulk Pack)	-B	1,000	Bulk
AH3320Q-SA-7	SA	SOT23 (Type S)	-7	3,000	7" Tape & Reel
AH3321Q-P-B	P	SIP-3 (Bulk Pack)	-B	1,000	Bulk
AH3321Q-SA-7	SA	SOT23 (Type S)	-7	3,000	7" Tape & Reel

Notes: 14. Ammo Box is for SIP-3 Spread Lead.
 15. Bulk is for SIP-3 Straight Lead.
 16. For packaging details, go to our website at <https://www.diodes.com/design/support/packaging/diodes-packaging/>.

Marking Information

(1) Package Type: SOT23 (Type S)

(Top View)

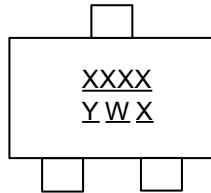

XXXX : Identification Code
Y : Year 0 to 9 (ex: 5 = 2025)
W : Week : A to Z : week 1 to 26;
 a to z : week 27 to 52; z represents
 week 52 and 53
X : Internal Code

Orderable Part Number	Package	Identification Code
AH3322Q-SA-7	SOT23 (Type S)	S2AQ
AH3323Q-SA-7	SOT23 (Type S)	S2BQ
AH3324Q-SA-7	SOT23 (Type S)	S2CQ
AH3325Q-SA-7	SOT23 (Type S)	S2DQ
AH3326Q-SA-7	SOT23 (Type S)	S2EQ
AH3327Q-SA-7	SOT23 (Type S)	S2FQ
AH3328Q-SA-7	SOT23 (Type S)	S2GQ
AH3329Q-SA-7	SOT23 (Type S)	S2HQ
AH3320Q-SA-7	SOT23 (Type S)	S2JQ
AH3321Q-SA-7	SOT23 (Type S)	S2KQ

(2) Package Type: SC59

(Top View)

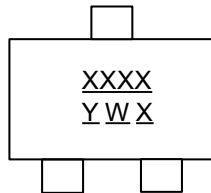

XXXX : Identification Code
Y : Year 0 to 9 (ex: 5 = 2025)
W : Week : A to Z : week 1 to 26;
 a to z : week 27 to 52; z represents
 week 52 and 53
X : Internal Code

Orderable Part Number	Package	Identification Code
AH3322Q-W-7	SC59	S3AQ
AH3323Q-W-7	SC59	S3BQ
AH3326Q-W-7	SC59	S3EQ
AH3327Q-W-7	SC59	S3FQ

Marking Information (continued)

(3) Package Types: SIP-3 (Ammo Pack)/SIP-3 (Bulk Pack)

(Top View)

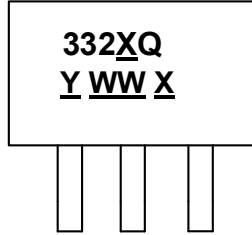

332XQ : Identification Code
Y : Year : 0 to 9 (ex: 5 = 2025)
WW : Week : 01 to 52, "52" represents week 52 and 53
X : Internal Code

Orderable Part Number	Package	Identification Code
AH3322Q-P-A	SIP-3 (Ammo Pack)	3322Q
AH3322Q-P-B	SIP-3 (Bulk Pack)	3322Q
AH3323Q-P-A	SIP-3 (Ammo Pack)	3323Q
AH3323Q-P-B	SIP-3 (Bulk Pack)	3323Q
AH3324Q-P-B	SIP-3 (Bulk Pack)	3324Q
AH3325Q-P-B	SIP-3 (Bulk Pack)	3325Q
AH3326Q-P-A	SIP-3 (Ammo Pack)	3326Q
AH3326Q-P-B	SIP-3 (Bulk Pack)	3326Q
AH3327Q-P-A	SIP-3 (Ammo Pack)	3327Q
AH3327Q-P-B	SIP-3 (Bulk Pack)	3327Q
AH3328Q-P-A	SIP-3 (Ammo Pack)	3328Q
AH3328Q-P-B	SIP-3 (Bulk Pack)	3328Q
AH3329Q-P-B	SIP-3 (Bulk Pack)	3329Q
AH3320Q-P-B	SIP-3 (Bulk Pack)	3320Q
AH3321Q-P-B	SIP-3 (Bulk Pack)	3321Q

Package Outline Dimensions (All dimensions in mm.)

Please see <http://www.diodes.com/package-outlines.html> for the latest version.

(1) Package Type: SOT23 (Type S)

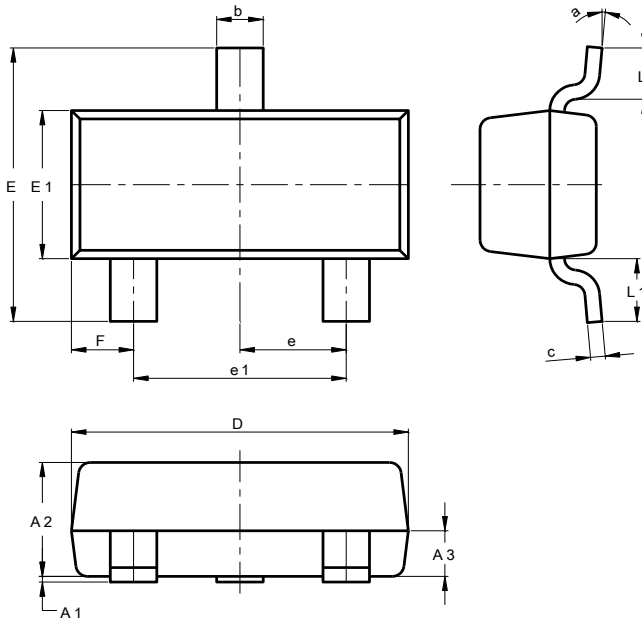

SOT23 (Type S)			
Dim	Min	Max	Typ
A1	0.013	0.10	0.05
A2	0.90	1.025	1.00
A3	0.375	0.425	0.40
b	0.37	0.51	0.40
c	0.10	0.18	0.125
D	2.80	3.00	2.90
E	2.30	2.50	2.40
E1	1.20	1.40	1.30
e	0.89	1.03	0.915
e1	1.78	2.05	1.83
F	0.45	0.60	0.535
L1	0.45	0.61	0.55
L	0.25	0.55	0.40
a	0°	8°	--
All Dimensions in mm			

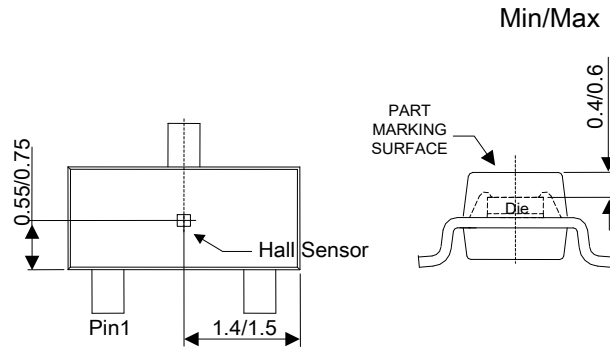

Sensor Location

Package Outline Dimensions (All dimensions in mm.) (continued)

Please see <http://www.diodes.com/package-outlines.html> for the latest version.

(2) Package Type: SC59

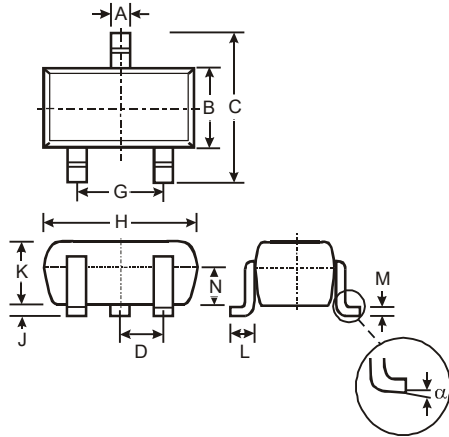

SC59			
Dim	Min	Max	Typ
A	0.35	0.50	0.38
B	1.50	1.70	1.60
C	2.70	3.00	2.80
D	-	-	0.95
G	-	-	1.90
H	2.90	3.10	3.00
J	0.013	0.10	0.05
K	1.00	1.30	1.10
L	0.35	0.55	0.40
M	0.10	0.20	0.15
N	0.70	0.80	0.75
α	0°	8°	-
All Dimensions in mm			

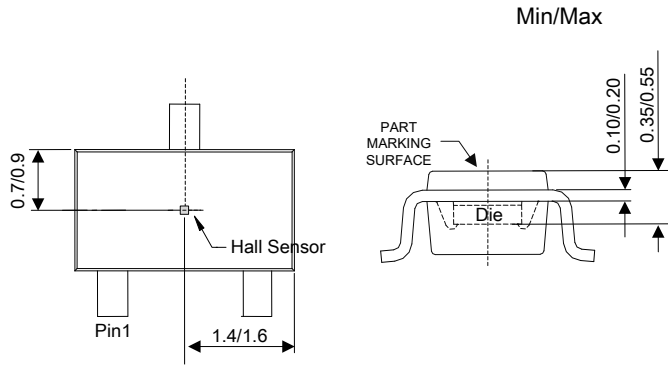

Sensor Location

Package Outline Dimensions (All dimensions in mm.) (continued)

Please see <http://www.diodes.com/package-outlines.html> for the latest version.

(3) Package Type: SIP-3 (Bulk Pack)

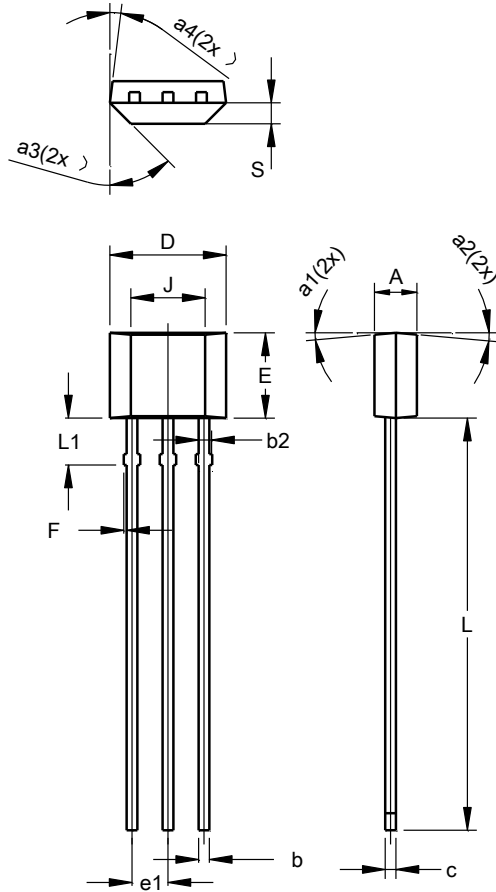

SIP-3 (Bulk Pack)			
Dim	Min	Max	Typ
A	1.40	1.60	1.50
b	0.33	0.43	0.38
b2	0.40	0.508	0.46
c	0.35	0.41	0.38
D	3.90	4.30	4.10
E	2.80	3.20	3.00
e1	1.24	1.30	1.27
F	0.00	0.20	--
J	2.62 REF		
L	14.00	15.00	14.50
L1	1.55	1.75	1.65
S	0.63	0.84	0.74
a1	--	--	5°
a2	--	--	5°
a3	--	--	45°
a4	--	--	3°
All Dimensions in mm			

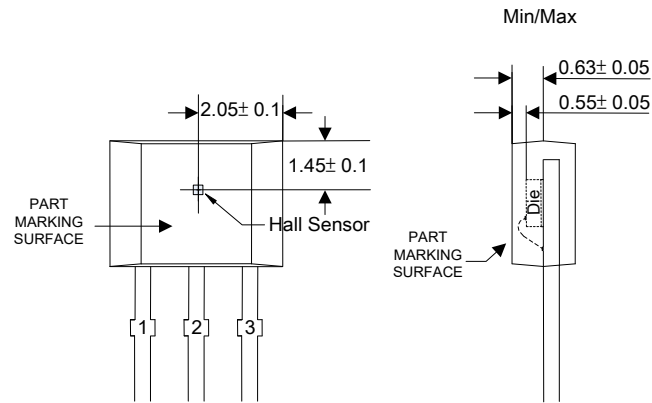

Sensor Location

Package Outline Dimensions (All dimensions in mm.) (continued)

Please see <http://www.diodes.com/package-outlines.html> for the latest version.

(4) Package Type: SIP-3 (Ammo Pack)

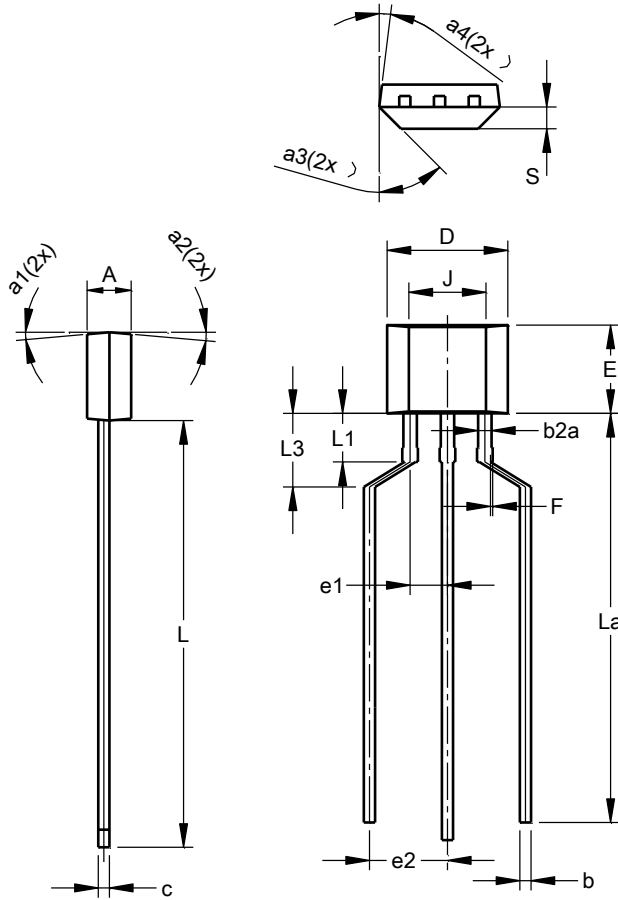

SIP-3 (Ammo Pack)			
Dim	Min	Max	Typ
A	1.40	1.60	1.50
b	0.33	0.43	0.38
b2a	0.40	0.52	0.46
c	0.35	0.41	0.38
D	3.90	4.30	4.10
E	2.80	3.20	3.00
e1	1.24	1.30	1.27
e2	2.40	2.90	2.65
F	0.00	0.20	--
J	2.62 REF		
L	14.00	15.00	14.50
La	12.90	14.90	13.90
L1	1.55	1.75	1.65
L3	2.00	3.00	2.50
S	0.63	0.84	0.74
a1	--	--	5°
a2	--	--	5°
a3	--	--	45°
a4	--	--	3°
All Dimensions in mm			

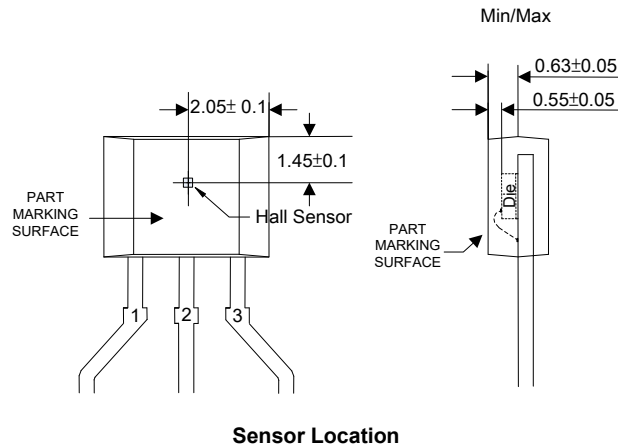

Suggested Pad Layout

Please see <http://www.diodes.com/package-outlines.html> for the latest version.

(1) Package Type: SOT23 (Type S)

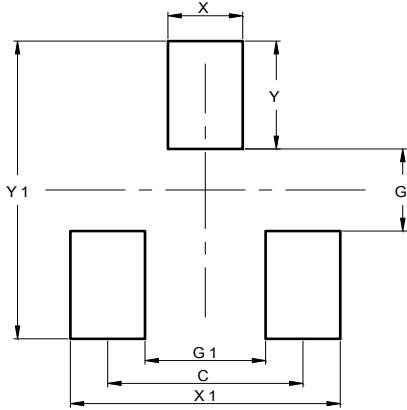

Dimensions	Value (in mm)
C	1.830
G	0.800
G1	1.130
X	0.700
X1	2.530
Y	1.050
Y1	2.900

(2) Package Type: SC59

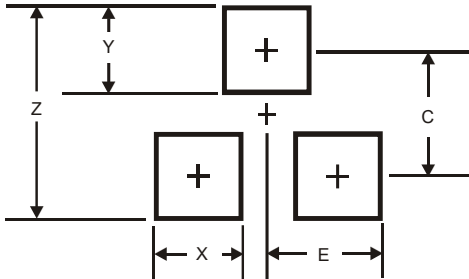

Dimensions	Value (in mm)
Z	3.4
X	0.8
Y	1.0
C	2.4
E	1.35

Mechanical Data

- Moisture Sensitivity: SOT23 (Type S)/SC59 – Level 1 per J-STD-020
- Terminals: Finish – Matte Tin Plated Leads, Solderable per MIL-STD-202, Method 208 (G3)
- Weight:
 - SIP-3 (Ammo Pack)/SIP-3 (Bulk Pack): 0.077 grams (Approximate)
 - SOT23 (Type S): 0.009 grams (Approximate)
 - SC59: 0.015 grams (Approximate)

IMPORTANT NOTICE

1. DIODES INCORPORATED (Diodes) AND ITS SUBSIDIARIES MAKE NO WARRANTY OF ANY KIND, EXPRESS OR IMPLIED, WITH REGARDS TO ANY INFORMATION CONTAINED IN THIS DOCUMENT, INCLUDING, BUT NOT LIMITED TO, THE IMPLIED WARRANTIES OF MERCHANTABILITY, FITNESS FOR A PARTICULAR PURPOSE OR NON-INFRINGEMENT OF THIRD PARTY INTELLECTUAL PROPERTY RIGHTS (AND THEIR EQUIVALENTS UNDER THE LAWS OF ANY JURISDICTION).
2. The Information contained herein is for informational purpose only and is provided only to illustrate the operation of Diodes' products described herein and application examples. Diodes does not assume any liability arising out of the application or use of this document or any product described herein. This document is intended for skilled and technically trained engineering customers and users who design with Diodes' products. Diodes' products may be used to facilitate safety-related applications; however, in all instances customers and users are responsible for (a) selecting the appropriate Diodes products for their applications, (b) evaluating the suitability of Diodes' products for their intended applications, (c) ensuring their applications, which incorporate Diodes' products, comply the applicable legal and regulatory requirements as well as safety and functional-safety related standards, and (d) ensuring they design with appropriate safeguards (including testing, validation, quality control techniques, redundancy, malfunction prevention, and appropriate treatment for aging degradation) to minimize the risks associated with their applications.
3. Diodes assumes no liability for any application-related information, support, assistance or feedback that may be provided by Diodes from time to time. Any customer or user of this document or products described herein will assume all risks and liabilities associated with such use, and will hold Diodes and all companies whose products are represented herein or on Diodes' websites, harmless against all damages and liabilities.
4. Products described herein may be covered by one or more United States, international or foreign patents and pending patent applications. Product names and markings noted herein may also be covered by one or more United States, international or foreign trademarks and trademark applications. Diodes does not convey any license under any of its intellectual property rights or the rights of any third parties (including third parties whose products and services may be described in this document or on Diodes' website) under this document.
5. Diodes' products are provided subject to Diodes' Standard Terms and Conditions of Sale (<https://www.diodes.com/about/company/terms-and-conditions/terms-and-conditions-of-sales/>) or other applicable terms. This document does not alter or expand the applicable warranties provided by Diodes. Diodes does not warrant or accept any liability whatsoever in respect of any products purchased through unauthorized sales channel.
6. Diodes' products and technology may not be used for or incorporated into any products or systems whose manufacture, use or sale is prohibited under any applicable laws and regulations. Should customers or users use Diodes' products in contravention of any applicable laws or regulations, or for any unintended or unauthorized application, customers and users will (a) be solely responsible for any damages, losses or penalties arising in connection therewith or as a result thereof, and (b) indemnify and hold Diodes and its representatives and agents harmless against any and all claims, damages, expenses, and attorney fees arising out of, directly or indirectly, any claim relating to any noncompliance with the applicable laws and regulations, as well as any unintended or unauthorized application.
7. While efforts have been made to ensure the information contained in this document is accurate, complete and current, it may contain technical inaccuracies, omissions and typographical errors. Diodes does not warrant that information contained in this document is error-free and Diodes is under no obligation to update or otherwise correct this information. Notwithstanding the foregoing, Diodes reserves the right to make modifications, enhancements, improvements, corrections or other changes without further notice to this document and any product described herein. This document is written in English but may be translated into multiple languages for reference. Only the English version of this document is the final and determinative format released by Diodes.
8. Any unauthorized copying, modification, distribution, transmission, display or other use of this document (or any portion hereof) is prohibited. Diodes assumes no responsibility for any losses incurred by the customers or users or any third parties arising from any such unauthorized use.
9. This Notice may be periodically updated with the most recent version available at <https://www.diodes.com/about/company/terms-and-conditions/important-notice>

The Diodes logo is a registered trademark of Diodes Incorporated in the United States and other countries.
All other trademarks are the property of their respective owners.
© 2025 Diodes Incorporated. All Rights Reserved.

www.diodes.com