

DESCRIPTION

- Collector-Emitter Breakdown Voltage-
: $V_{(BR)CEO} = 45V(\text{Min})$
- High DC Current Gain
: $h_{FE} = 750(\text{Min}) @ I_C = 3A$
- Collector Power Dissipation-
: $P_C = 70W @ T_C = 25^\circ C$
- 8 A Continuous Collector Current
- Complement to Type BD896

APPLICATIONS

- Designed for use as complementary AF push-pull output stage applications

ABSOLUTE MAXIMUM RATINGS ($T_a = 25^\circ C$)

SYMBOL	PARAMETER	VALUE	UNIT
V_{CBO}	Collector-Base Voltage	45	V
V_{CEO}	Collector-Emitter Voltage	45	V
V_{EBO}	Emitter-Base Voltage	5	V
I_C	Collector Current-Continuous	8	A
I_B	Base Current-Continuous	0.3	A
P_C	Collector Power Dissipation @ $T_a = 25^\circ C$	2	W
	Collector Power Dissipation @ $T_C = 25^\circ C$	70	
T_J	Junction Temperature	150	$^\circ C$
T_{stg}	Storage Temperature Range	-65~150	$^\circ C$

THERMAL CHARACTERISTICS

SYMBOL	PARAMETER	MAX	UNIT
$R_{th\ j-c}$	Thermal Resistance, Junction to Case	1.79	$^\circ C/W$
$R_{th\ j-a}$	Thermal Resistance, Junction to Ambient	62.5	$^\circ C/W$

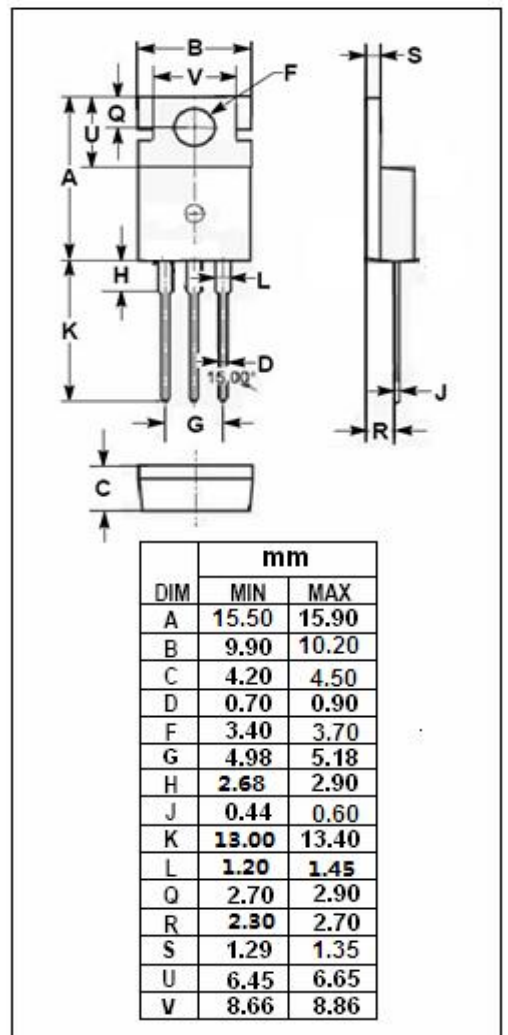
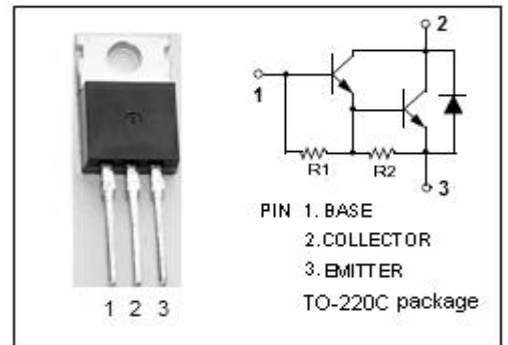

ELECTRICAL CHARACTERISTICS

$T_C=25^{\circ}\text{C}$ unless otherwise specified

SYMBOL	PARAMETER	CONDITIONS	MIN	TYP.	MAX	UNIT
$V_{(BR)CEO}$	Collector-Emitter Breakdown Voltage	$I_C=50\text{mA}; I_B=0$	45			V
$V_{CE(sat)}$	Collector-Emitter Saturation Voltage	$I_C=3\text{A}; I_B=12\text{mA}$			2.5	V
$V_{BE(on)}$	Base-Emitter On Voltage	$I_C=3\text{A}; V_{CE}=3\text{V}$			2.5	V
I_{CBO}	Collector Cutoff Current	$V_{CB}=45\text{V}; I_E=0$			0.2	mA
		$V_{CB}=45\text{V}; I_E=0; T_C=100^{\circ}\text{C}$			2.0	
I_{CEO}	Collector Cutoff Current	$V_{CE}=30\text{V}; I_B=0$			0.5	mA
I_{EBO}	Emitter Cutoff Current	$V_{EB}=5\text{V}; I_C=0$			2	mA
h_{FE}	DC Current Gain	$I_C=3\text{A}; V_{CE}=3\text{V}$	750			

Switching Times

t_{on}	Turn-On Time	$I_C=3\text{A}; I_{B1}=-I_{B2}=12\text{mA};$ $V_{BE(off)}=-3.5\text{V}; R_L=10\Omega;$ $t_p=20\mu\text{s}, \text{DutyCycle} \leq 2\%$		1		μs
t_{off}	Turn-Off Time			5		μs