



E22-900T33S Product Specification

AT command 868 / 915MHz 2W LoRa Wireless module



DISCLAIMER AND COPYRIGHT NOTICE	3
1 PRODUCT OVERVIEW	4
1.1 PRODUCT INTRODUCTION	4
1.2 FEATURES	4
1.3 APPLICATION SCENARIO	5
2 SPECIFICATIONS	5
2.1 LIMIT PARAMETER	5
2.2 WORKING PARAMETERS	5
3 MECHANICAL DIMENSIONS AND PIN DEFINITIONS	6
4 RECOMMENDED CONNECTION DIAGRAM	7
5 FUNCTION DETAILED EXPLANATION	8
5.1 FIXED - POINT LAUNCH	8
5.2 BROADCAST TRANSMISSION	9
5.3 BROADCAST ADDRESS	9
5.4 LISTENING ADDRESS	9
5.5 MODULE RESET	9
5.6 DETAILED EXPLANATION OF AUX	10
5.6.1 <i>Serial port data output indication</i>	10
5.6.2 <i>Wireless transmission indication</i>	10
5.6.3 <i>The module is being configured</i>	11
5.6.4 <i>Precautions</i>	11
6. WORKING MODE	12
6.1 PRECAUTIONS FOR MODE SWITCHING	12
6.2 NORMAL MODE (MODE 0)	13
6.3 WOR MODE (MODE 1)	13
6.4 CONFIGURATION MODE (MODE 2)	13
6.5 DEEP SLEEP MODE (MODE 3)	13
7. REGISTER READ AND WRITE CONTROL	14
7.1 COMMAND FORMAT	14
7.2 E22-400/900T30D, E22-400/900T30S REGISTER DESCRIPTION	15
7.3 FACTORY DEFAULT PARAMETERS	18

8. AT COMMAND	19
8.1 AT COMMAND LIST	19
8.2 AT PARAMETER ANALYSIS	21
8.3 NOTES FOR UPGRADING FIRMWARE VIA SERIAL PORT	21
9 USE OF RELAY NETWORKING MODE	22
10 PC CONFIGURATION INSTRUCTIONS	23
11HARDWARE DESIGN	24
12 FREQUENTLY ASKED QUESTIONS	25
12.1 THE TRANSMISSION DISTANCE IS NOT IDEAL	25
12.2 THE MODULE IS EASILY DAMAGED	25
12.3 BIT ERROR RATE IS TOO HIGH	25
13 WELDING OPERATION INSTRUCTIONS	26
13.1 REFLOW SOLDERING TEMPERATURE	26
13.2 REFLOW SOLDERING CURVE	27
14 RELATED MODELS	27
15 ANTENNA GUIDE	28
16 BATCH PACKAGING METHOD	29
REVISE HISTORY	29
ABOUT US	29

Disclaimer and Copyright Notice

Information in this document, including URL references, is subject to change without notice. The documentation is provided "as is" without any warranty of any kind, including any warranties of merchantability, fitness for a particular purpose, or non-infringement, and any warranties mentioned elsewhere in any proposal, specification, or sample. This document disclaims any responsibility, including liability for infringement of any patent rights arising out of the use of the information in this document. No license, express or implied, to any intellectual property right is hereby granted by this document, whether by estoppel or otherwise.

The test data obtained in this article are all obtained from Ebyte laboratory tests, and the actual results may be slightly different.

All trade names, trademarks and registered trademarks mentioned herein are the property of their respective owners and are hereby declared.

The final interpretation right belongs to Chengdu Ebyte Electronic Technology Co., Ltd.

Note :

Due to product version upgrades or other reasons, the contents of this manual may change. Ebyte Electronic Technology Co., Ltd. reserves the right to modify the contents of this manual without any notice or prompt. This manual is only used as a guide. Chengdu Ebyte Electronic Technology Co., Ltd. makes every effort to provide accurate information in this manual, but Chengdu Ebyte Electronic Technology Co., Ltd. does not guarantee that the content of the manual is completely error-free. All statements in this manual, information and advice do not constitute any express or implied warranty.

1 Product Overview

1.1 product introduction

E22-900T33S is a new generation of LoRa wireless data transmission module, this module(UART) is based on SEMTECH high-performance RF chip and developed. Spread spectrum technology, TTL level output, compatible with 3.3V and 5V IO port voltage.

E22-900T33S adopts a new generation of LoRa spread spectrum technology. faster speed, lower power consumption, and smaller size; it supports air wake-up, wireless configuration, and carrier sense. , automatic relay, communication key and other functions, support subpackage length setting, and can provide customized development services.



1.2 Features

- Developed a new LoRa spread spectrum modulation technology based on SEMTECH high-performance RF chip, which brings longer communication distance and stronger anti-interference ability;
- Support automatic relay networking, multi-level relay is suitable for ultra-long-distance communication , and multiple networks run simultaneously in the same area ;
- Support users to set the communication key by themselves, and it cannot be read, which greatly improves the confidentiality of user data;
- Support LBT function , monitor the channel environment noise before sending, which can greatly improve the communication success rate of the module in harsh environments ;
- Support RSSI signal strength indication function , used to evaluate signal quality, improve communication network, distance measurement;
- Support wireless parameter configuration, send command packets wirelessly, remotely configure or read wireless module parameters ;
- Support air wake-up, that is, ultra-low power consumption function, suitable for battery-powered applications;
- Support fixed-point transmission, broadcast transmission, channel monitoring;
- Support deep sleep, the power consumption of the whole machine is about 4uA in this mode ;
- Support global license-free ISM 868/915 MHz frequency band ;
- The module has built-in PA + LNA , and the communication distance can reach 16 km under ideal conditions;
- The parameters are saved after power-off , and the module will work according to the set parameters after power-on ;
- Efficient watchdog design, once an exception occurs, the module will automatically restart and continue to work according to the previous parameter settings ;
- Support data transmission rate of 2.4k ~ 62.5k bps ;
- Support 3.3 ~ 5.5V power supply, power supply greater than 5V can guarantee the best performance;
- Industrial-grade standard design, supporting long-term use at -40 ~ + 85 °C;
- Dual antennas are optional (IPEX/ stamp hole) , which is convenient for secondary development and integration.

1.3 Application Scenario

- Home security alarm and remote keyless entry;
- Smart home and industrial sensors, etc.;
- Wireless alarm security system ;
- Building automation solutions;
- Wireless industrial grade remote control;
- healthcare products;
- Advanced Meter Reading Infrastructure (AMI);
- Automotive industry applications.

2 Specifications

2.1 Limit parameter

The main parameters	performance		Remark
	minimum value	maximum value	
Power supply voltage (V)	3.3	5.5	Exceeding 5.5V may permanently burn the module
Blocking power (dBm)	-	10	Less chance of burning when used at close range
Working temperature (°C)	-40	+85 _	industrial grade

2.2 Working parameters

The main parameters	performance			Remark	
	minimum value	typical value	maximum value		
Working voltage (V)	3.3	5.0	5.5	≥5.0V guaranteed output power	
Communication level (V)		3.3 _		when using a 5V level	
Working temperature (°C)	-40	-	+85 _	industrial design	
Working frequency band (MHz)	850.125	-	930.125 _	Support ISM frequency band	
power consumption	Emission current (mA)	-	1200	-	Instantaneous power consumption @3 dBm
	Receive current (mA)	-	14	-	-
	Sleep current (uA)	-	3	-	software shutdown

Maximum transmit power (dBm)	32	33	34	-
Receiving sensitivity (dBm)	-123	-124	-125	Air rate 2.4 kbps
Air rate (bps)	2.4k _	2.4k	62.5k	User Programmable Control
Reference distance	16km _ _			Clear sky, antenna gain 5dBi, antenna height 2.5 meters, air rate 2.4kbps
launch length	2 4 0 Byte			4 0 bytes can be sent by command setting
cache capacity	1000 Byte			-
Modulation	LoRa			A new generation of Lo R a modulation technology
Communication Interface	UART serial port			T TL level
Encapsulation	SMD _			-
Interface	stamp hole			Stamp hole, pitch 2.54mm
Dimensions	25*40.5mm			-
RF interface	IPEX/stamp hole			Equivalent impedance about 50 Ω

3 Mechanical Dimensions and Pin Definitions

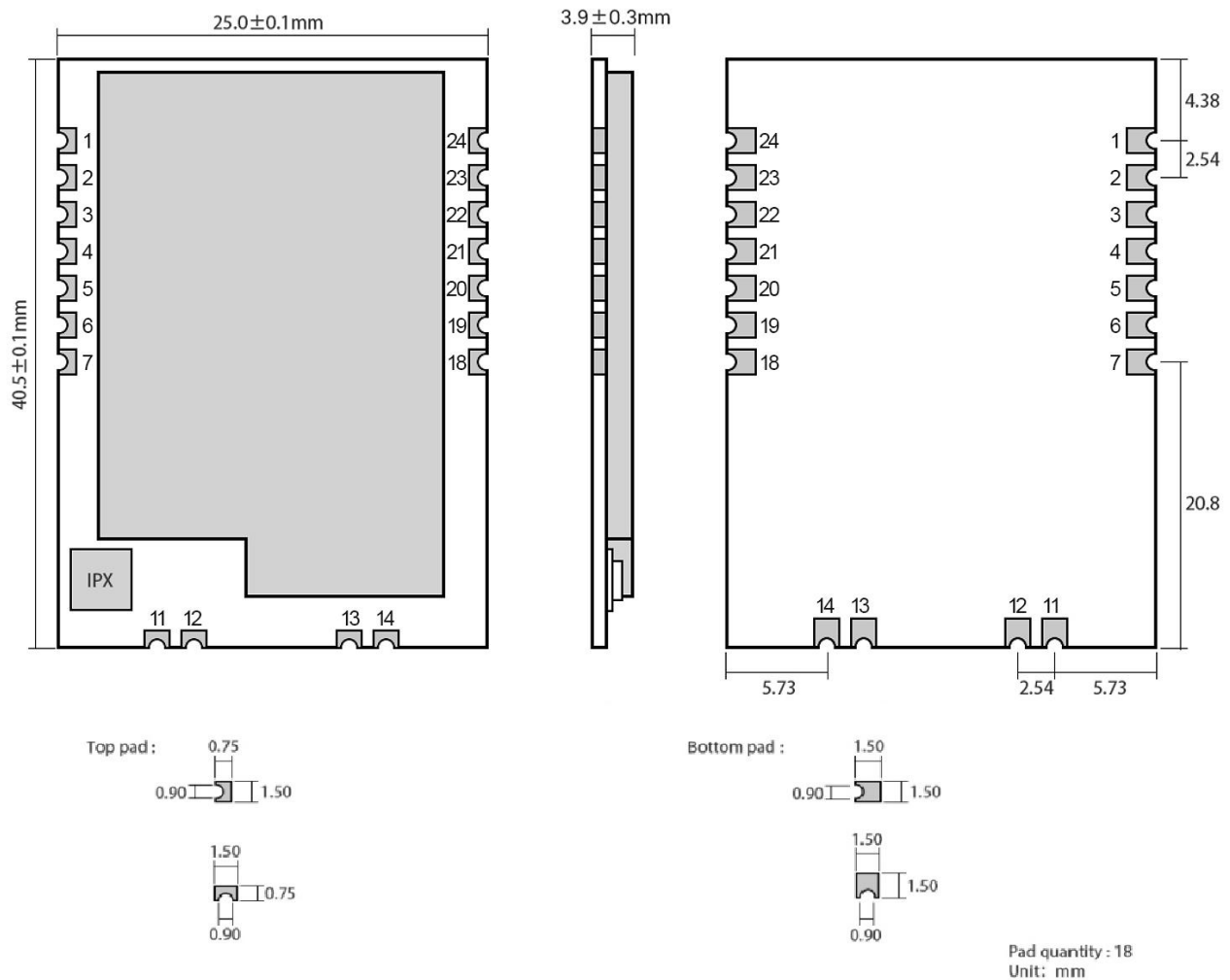

pin number	pin name	Pin direction	Pin usage
1	GND	enter	Module ground
2	VCC	enter	Module power positive reference, voltage range: 3.3 ~ 5.5V DC
3	AUX	output	Used to indicate the working status of the module; the user wakes up the external MCU, and outputs a low level during the initialization of the power-on self-test; (can be suspended)
4	TXD	output	TTL serial port output, connected to external RXD input pin;
5	RXD	enter	TTL serial port input, connected to the external TXD output pin;
6	M1	Input (very weak pull-up)	Cooperate with M0 to determine the 4 working modes of the module (not floating, if not used, it can be grounded)
7	M0	Input (very weak pull-up)	Cooperate with M1 to determine the 4 working modes of the module (not floating, if not used, it can be grounded)
11	ANT	output	Antenna interface (high-frequency signal output, 50 ohm characteristic impedance)
12	GND		Fixedly
13	GND		Fixedly
14	GND		Fixedly
18	NC	-	NC pin, this pin needs to be suspended (for subsequent expansion)
19	NC	-	NC pin, this pin needs to be suspended (for subsequent expansion)
20	NC	-	NC pin, this pin needs to be suspended (for subsequent expansion)
21	NC	-	empty feet
22	RESET	enter	Module reset pin
23	GND	-	Module ground
24	NC	-	empty feet

4 Recommended Connection Diagram

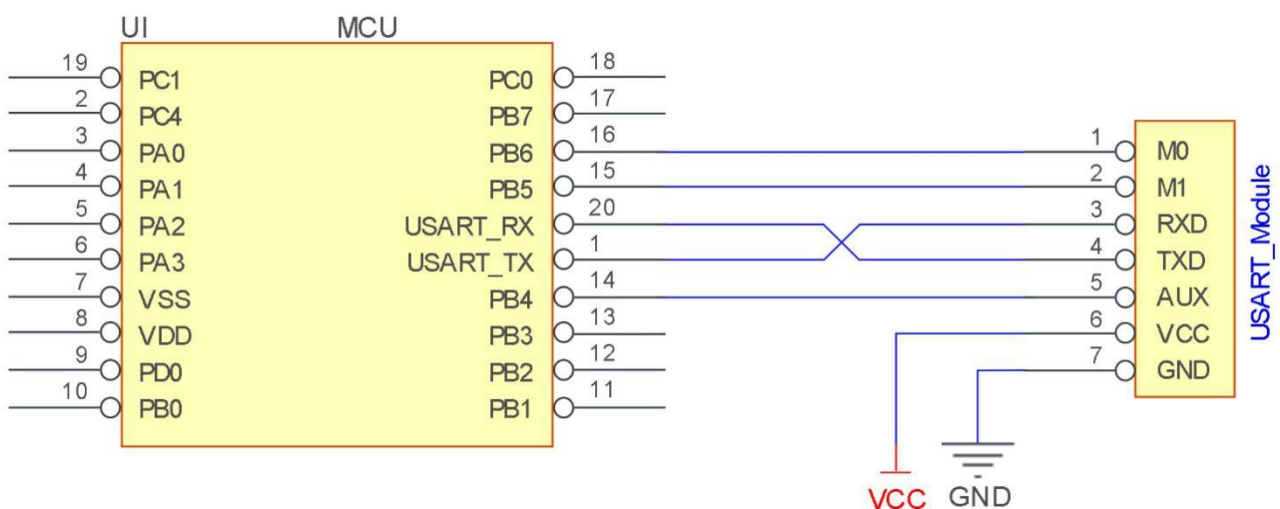

serial number	A brief description of the connection between the module and the microcontroller (the above figure takes the STM8L microcontroller as an example)
1	The wireless serial port module is TTL level, please connect it with TTL level MCU.
2	For some 5V microcontrollers, it may be necessary to add 4 ~ 10K pull-up resistors to the TXD and AUX pins of the module.

5 Function Detailed Explanation

5.1 Fixed - point launch

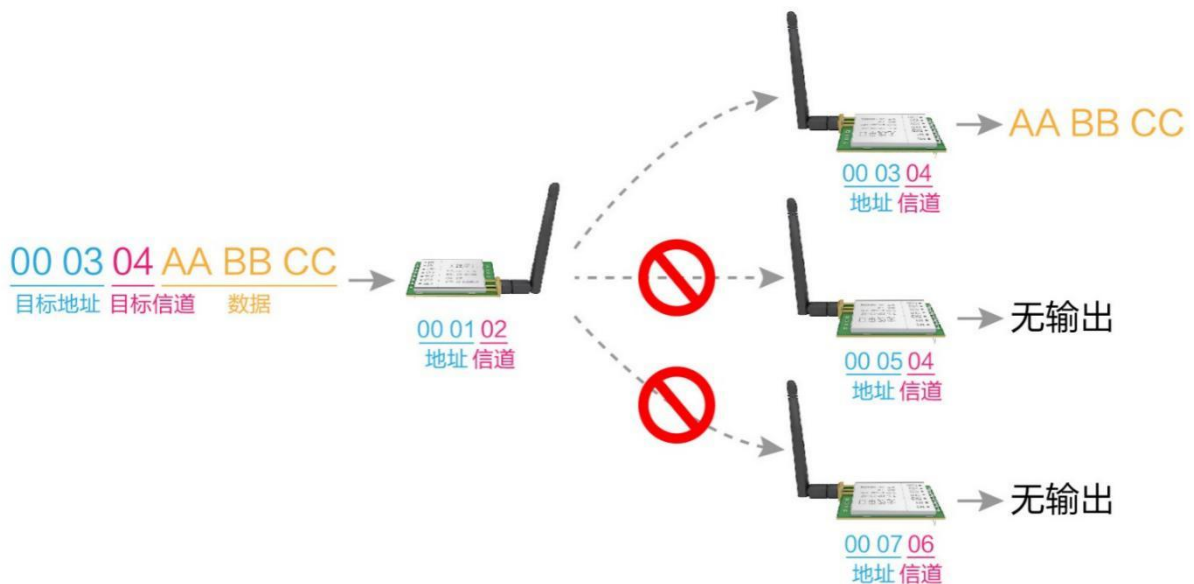

5.2 Broadcast transmission

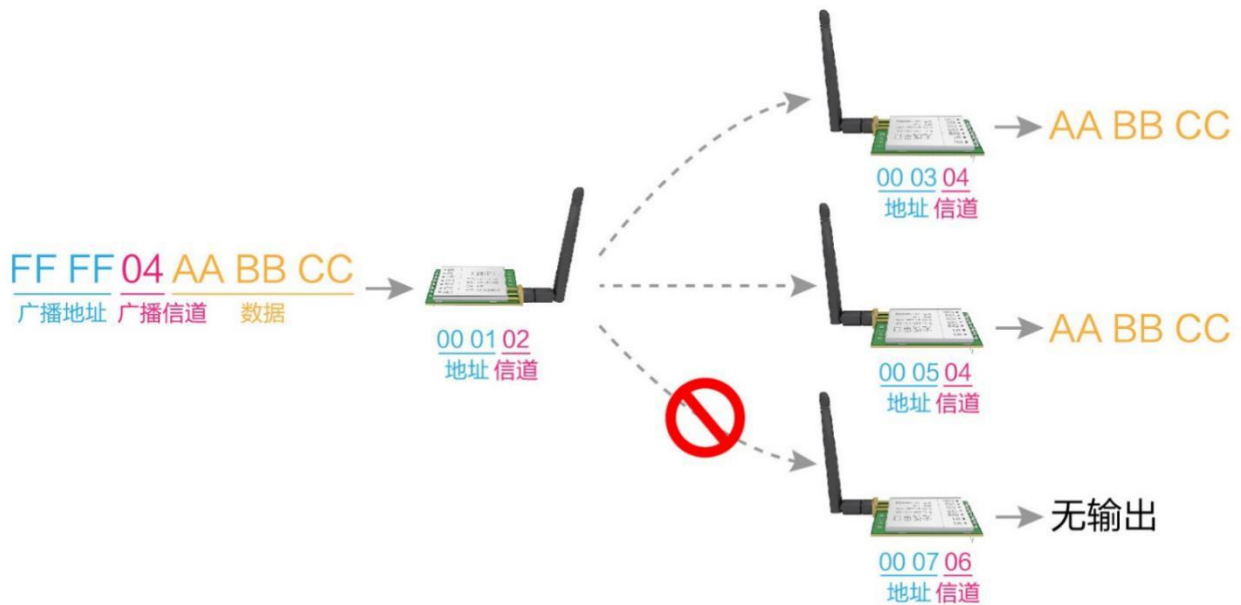

5.3 Broadcast address

- Example: Set the address of module A to 0xFFFF, and the channel to 0x04.
- When module A is used as a transmitter (same mode, transparent transmission mode), all receiving modules under the 0x04 channel can receive data to achieve the purpose of broadcasting.

5.4 Listening address

- Example: Set the address of module A to 0xFFFF, and the channel to 0x04.
- When module A is used as a receiver, it can receive all the data under the 0x04 channel to achieve the purpose of monitoring.

5.5 Module reset

- After the module is powered on, AUX will immediately output low level, and perform hardware self-test, and set the working mode according to user parameters;
During this process, AUX keeps low level, and after the completion, AUX outputs high level, and starts to work normally according to the working mode combined by M1 and M0;
Therefore, the user needs to wait for the rising edge of AUX as the starting point for the normal operation of the module.

5.6 Detailed explanation of AUX

- AUX is used for wireless transceiver buffer indication and self-test indication.
- It indicates whether the module has data that has not been transmitted through the wireless, or whether the received wireless data has not been sent through the serial port, or the module is in the process of initializing self-test.

5.6.1 Serial port data output indication

- Used to wake up the external MCU in sleep;

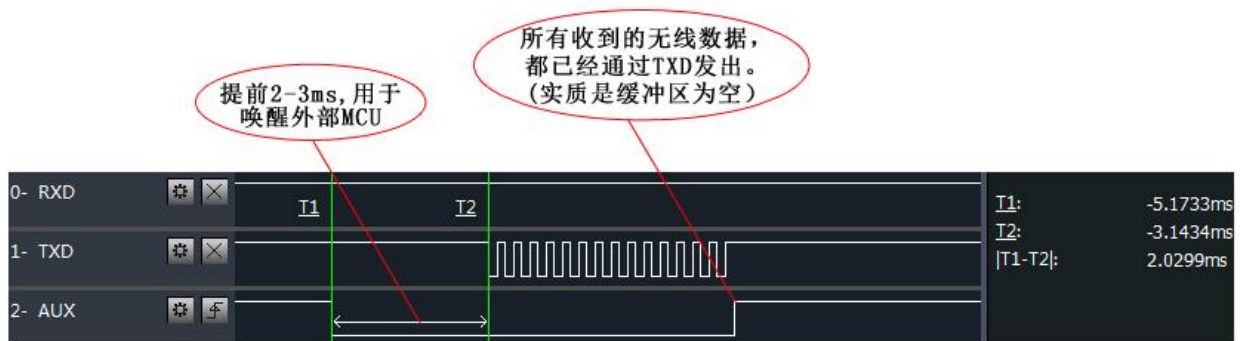

模块串口外发数据时，AUX引脚时序图

5.6.2 Wireless transmission indication

- Buffer is empty: the data in the internal 1000-byte buffer is written to the wireless chip (automatically subpackaged) ;
When AUX=1, the user continuously initiates data less than 1000 bytes, which will not overflow ;
When AUX=0, the buffer is not empty: the data in the internal 1000-byte buffer has not been written into the wireless chip and the transmission is started. At this time, the module may be waiting for the end of user data to time out, or it is transmitting wireless packets..

【Note】 : When AUX=1, it does not mean that all serial port data of the module has been transmitted wirelessly, or the last packet of data may be being transmitted.

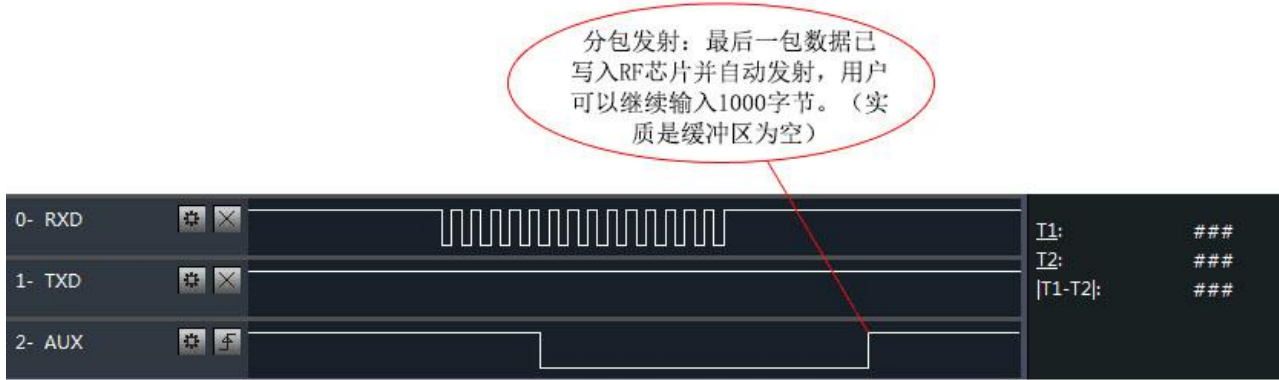

模块接收串口数据时，AUX引脚时序图

5.6.3 The module is being configured

- only on reset and when exiting sleep mode;

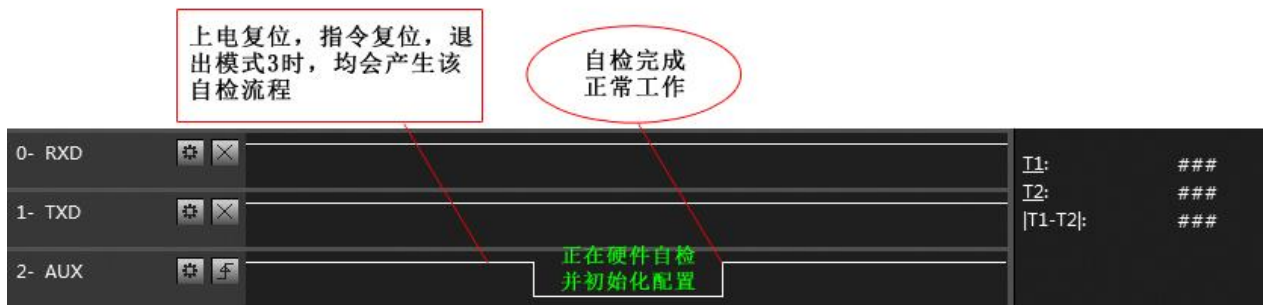

自检期间，AUX引脚时序图

5.6.4 Precautions _

serial number	Notes on AUX
1	The above function 1 and function 2, output low level priority, that is: if any output low level condition is met, AUX will output low level; When all low-level conditions are not met, AUX outputs high level.
2	When the AUX outputs a low level, it means the module is busy, and the working mode detection will not be performed at this time; When the module AUX outputs a high level within 1ms, the mode switching will be completed.
3	After the user switches to a new working mode, at least 2ms after the rising edge of AUX, the module will actually enter this mode; If AUX is always at high level, then the mode switch will take effect immediately.
4	When the user enters other modes from mode 3 (sleep mode) or during the reset process, the module will reset the user parameters, during which AUX outputs low level.
5	Due to the characteristics of the LoRa modulation method, the information transmission delay is much longer than that of FSK. It is recommended that customers do not transmit large amounts of data at low airspeeds to avoid communication abnormalities caused by data loss due to data accumulation.

6. Working Mode

The module has four working modes, which are set by pins M1 and M0; details are shown in the following table:

Mode (0-3)	M1	M0	Mode introduction	Remark
0 Transmission Mode	0	0	UART and wireless channel are open, transparent transmission is on	Support over-the-air configuration via special command
1 WOR Mode	0	1	Can be set as WOR Transmitter or WOR Receiver	Support wake up over the air
2 Configuration Mode	1	0	Users can access the registers through the serial port to control the working status of the module	
3 Deep Sleep Mode	1	1	Module goes to sleep	

6.1 Precautions for mode switching

No.	Remark
1	<ul style="list-style-type: none"> Users can combine high and low levels with M1 and M0 to determine the module's working mode. Two GPIOs of the MCU can be used to control mode switching; After changing M1 and M0: If the module is idle, after 1ms, it can start working according to the new mode; If there is serial port data of the module not been transmitted through the wireless, the new working mode can be switched after the transmission is completed; If the module receives the wireless data and transmits the data through the serial port, it needs to finish transmission before switching to the new working mode; Therefore, mode switching can only be valid when AUX output is 1, otherwise it will delay switching
2	<ul style="list-style-type: none"> For example, users continuously inputs a large amount of data and simultaneously performs mode switching. At this time, the switching mode operation is invalid; the module will process all the user data before performing the new mode detection; Therefore, the general recommendation is to detect the output state of the AUX pin and switch mode after 2ms when AUX outputs high level.
3	<ul style="list-style-type: none"> When the module is switched to sleep mode from other modes, if there is data not been processed yet, the module will process these data (including receiving and sending) before entering sleep mode. This feature can be used for fast sleep to save power; For example, the transmitter module works in mode 0, the user transmits the serial port data "12345". At the time, user does need to wait for the AUX pin to be idle (high level), user can directly switch the module to sleep mode and make user's main MCU immediately sleep, then the module will automatically transmit the user data through the wireless, and will enters sleep mode within 1ms automatically; This will saves MCU's working time and reduces its power consumption.
4	<ul style="list-style-type: none"> Similarly, any mode switching can use this feature. After the module processes the event in the current mode, it will automatically enter the new mode within 1ms; This saves the user's work of querying AUX and it achieves the purpose of fast switching; For example, switching from the transmit mode to the receive mode; the user MCU can also enter sleep before the mode switch, and use the external interrupt function to acquire the AUX change, thereby performing mode switching.
5	<ul style="list-style-type: none"> This operation mode is very flexible and efficient. It is designed according to the user's MCU's operation convenience, and it can reduce the workload of the entire system as much as possible, improving system efficiency, and reducing power consumption as well..

6.2 Normal mode (Mode 0)

Type	When M0 = 0, M1 = 0, module works in Mode 0
Transmitting	Users can input data through the serial port and the module will start wireless transmission.
Receiving	The module wireless receiving function is turned on, and after receiving the wireless data, it will be output through the serial port TXD pin.

6.3 WOR mode (Mode 1)

Type	When M0 = 1, M1 = 0, module works in Mode 1
Transmitting	When defined as the transmitter, the wake-up code for a certain period of time will be automatically added before transmitting
Receiving	Data can be received normally, and the receiving function is equivalent to that in mode 0

6.4 Configuration mode (Mode 2)

type	When M0 = 0, M1 = 1, the module works in mode 2
Transmitting	Wireless transmission is turned off and it will be automatically turned on during wireless configuration.
Receiving	Wireless reception is turned off and it will be automatically turned on during wireless configuration.
Configuration	Users can access registers to configure module's working status

6.5 Deep sleep mode (Mode 3)

Type	When M0 = 1, M1 = 1, module works in Mode 3
Transmitting	Unable to transmit wireless data.
Receiving	Unable to receive wireless data.
Note	When entering other modes from sleep mode, the module will reconfigure parameters. During the configuration process, AUX stays in low level; After completion of configuration, AUX will output a high level, so user is recommended to detect the rising edge of AUX.

7. Register Read and Write Control

7.1 Command format

In configuration mode (mode 2: M0 = 0, M1 = 1), the list of supported commands are as follows (**when setting, only 9600, 8N1 format is supported**):

No.	Command format	Detailed description															
1	Set register	Command: C0+starting address+length+parameters Response: C1+starting address+length+parameters E.g 1: Configure Channel to be 0x09 <table style="margin-left: 40px;"> <tr> <td>command</td> <td>starting address</td> <td>length</td> <td>parameter</td> </tr> <tr> <td>Send: C0</td> <td>05</td> <td>01</td> <td>09</td> </tr> <tr> <td>Return: C1</td> <td>05</td> <td>01</td> <td>09</td> </tr> </table> E.g 2: Configure module address (0x1234), network address (0x00), serial port (9600 8N1) and air data rate (2.4K). Send: C0 00 04 12 34 00 62 Return: C1 00 04 12 34 00 62	command	starting address	length	parameter	Send: C0	05	01	09	Return: C1	05	01	09			
command	starting address	length	parameter														
Send: C0	05	01	09														
Return: C1	05	01	09														
2	Read register	Command: C1+starting address+ length Response: C1+starting address+length+parameters E.g 1: Read channel <table style="margin-left: 40px;"> <tr> <td>command</td> <td>starting address</td> <td>length</td> <td>parameter</td> </tr> <tr> <td>Send: C1</td> <td>05</td> <td>01</td> <td></td> </tr> <tr> <td>Return: C1</td> <td>05</td> <td>01</td> <td>09</td> </tr> </table> E.g 2: Read module address, network address, serial port and air data rate. Send: C1 00 04 Return: C1 00 04 12 34 00 62	command	starting address	length	parameter	Send: C1	05	01		Return: C1	05	01	09			
command	starting address	length	parameter														
Send: C1	05	01															
Return: C1	05	01	09														
3	Set temporary register	Command: C2+starting address+length+parameters Response: C1+starting address+length+parameters E.g 1: Configure Channel to be 0x09 <table style="margin-left: 40px;"> <tr> <td>command</td> <td>starting address</td> <td>length</td> <td>parameter</td> </tr> <tr> <td>Send: C2</td> <td>05</td> <td>01</td> <td>09</td> </tr> <tr> <td>Return: C1</td> <td>05</td> <td>01</td> <td>09</td> </tr> </table> E.g 2: Configure module address (0x1234), network address (0x00), serial port (9600 8N1) and air data rate (2.4K). Send: C2 00 04 12 34 00 62 Return: C1 00 04 12 34 00 62	command	starting address	length	parameter	Send: C2	05	01	09	Return: C1	05	01	09			
command	starting address	length	parameter														
Send: C2	05	01	09														
Return: C1	05	01	09														
4	Wireless configuration	Command: CF CF + normal command Respond: CF CF + normal respond E.g 1: Configure Channel to be 0x09 by wireless configuration <table style="margin-left: 40px;"> <tr> <td>Command head</td> <td>command</td> <td>starting address</td> <td>length</td> <td>parameter</td> </tr> <tr> <td>Send: CF CF</td> <td>C0</td> <td>05</td> <td>01</td> <td>09</td> </tr> <tr> <td>Return: CF CF</td> <td>C1</td> <td>05</td> <td>01</td> <td>09</td> </tr> </table> E.g 2: Configure module address (0x1234), network address (0x00), serial port (9600 8N1) and air data rate (2.4K) by wireless configuration. Send: CF CF C0 00 04 12 34 00 62 Return: CF CF C1 00 04 12 34 00 62	Command head	command	starting address	length	parameter	Send: CF CF	C0	05	01	09	Return: CF CF	C1	05	01	09
Command head	command	starting address	length	parameter													
Send: CF CF	C0	05	01	09													
Return: CF CF	C1	05	01	09													

5	wrong format	Format error response FF FF FF
---	--------------	-----------------------------------

7.2 E22-400/900T30D, E22-400/900T30S register description

No.	Read or Write	Name	Description	Remark	
00H	Read/Write	ADDH	ADDH (default 0)	High byte and low byte in the module address; Note: When the module address is FFFF, it can be used as the broadcast and listening address, that is: the module will not perform address filtering.	
01H	Read/Write	ADDL	ADDL (default 0)		
02H	Read/Write	NETID	NETID (default 0)	Network address, used to distinguish the network. When two or more modules need to communicate with each other, their network address should be the same.	
03H	Read/Write	REG0	7 6 5	UART Serial port rate (bps)	For the two modules communicating with each other, their serial port baud rate can be different, and their serial parity bit can also be different. When transmitting large packets continuously, users need to consider the data blocking and possible data loss caused by the same baud rate. It is generally recommended that both communication parties have the same baud rate.
			0 0 0	Serial port baud rate 1200	
			0 0 1	Serial port baud rate 2400	
			0 1 0	Serial port baud rate 4800	
			0 1 1	Serial port baud rate 9600 (default)	
			1 0 0	Serial port baud rate 19200	
			1 0 1	Serial port baud rate 38400	
			1 1 0	Serial port baud rate 57600	
			1 1 1	Serial port baud rate 115200	
			4 3	Serial port parity bit	The communication parties can have different serial parity bit.
			0 0	8N1 (default)	
			0 1	8O1	
			1 0	8E1	
			1 1	8N1 (equal to 00)	
			2 1 0	Wireless air data rate (bps)	The communication parties must have the same air data rate. The higher the air data rate is, the smaller the delay in response, and the shorter the transmission distance is.
			0 0 0	Air data rate 2.4K	
			0 0 1	Air data rate 2.4K	
			0 1 0	Air data rate 2.4k (default)	
0 1 1	Air data rate 4.8k				
1 0 0	Air data rate 9.6k				
1 0 1	Air data rate 19.2k				
1 1 0	Air data rate 38.4k				
1 1 1	Air data rate 62.5k				
04H	Read/Write	REG1	7 6	Sub packet setting	When the data sent is smaller than the sub packet length, the serial output of the receiving end is an uninterrupted continuous output.
			0 0	240 bytes (default)	

			0	1	128 bytes	When the data sent is larger than the sub packet length, the serial port in receiving end will sub packet the data and then output them.
			1	0	64 bytes	
			1	1	32 bytes	
			5	RSSI environmental noise enable		RSSI enable command (Sub packet setting, transmit power as default parameters, configuration mode): C0 04 01 20;
			0	Disabled (default)		
			1	Enable		After enabling, the command C0 C1 C2 C3 can be sent in the normal mode(mode 0) or WOR transmission mode (transmitter in mode 1) to read the register; Register 0x00: current environmental noise RSSI; Register 0x01: RSSI at Last Data Received (Current channel noise is: dBm = -(256 - RSSI)); Command format: C0 C1 C2 C3+start address+read length; Return: C1 + address + read length + read valid value; For example: Send: C0 C1 C2 C3 00 01 Return: C1 00 01 RSSI (the address can only start from 00)
			4	3	Reserve	
			2	Software mode switching		If you use Ebyte's host computer configuration software, this bit will be turned off automatically. If you don't want to use the M0 M1 pins to switch working modes, you can enable this function, and use specific serial port commands to switch modes. Format: C0 C1 C2 C3 02 + working mode Send C0 C1 C2 C3 02 00 to switch to transparent transmission mode Send C0 C1 C2 C3 02 01 to switch to WOR mode Send C0 C1 C2 C3 02 02 to switch to configuration mode Send C0 C1 C2 C3 02 03 to switch to sleep mode Return: C1 C2 C3 02 + working mode Note: After enabling this function, WOR mode and sleep mode only support 9600 baud rate.
			0	Disabled (default)		
			1	Enable		
			1	0	Transmitting power	There is a non-linear relationship between power and current. At the maximum power, the power supply efficiency is the highest ; Current does not decrease proportionally with lower power.
			0	0	33dBm (default)	
			0	1	30dBm	
			1	0	27dBm	
			1	1	24dBm	
05H	Read/Write	REG2	Channel Control (CH) 0-80 respectively represent a total of 81 channels (applicable to the 900Mhz frequency band)			Actual frequency = 850.125MHz + CH * 1MHz
06H	Read/Write	REG3	7	Enable RSSI bytes		After enabled, when the module receives the wireless data, it will follow an RSSI strength byte after output via the serial port TXD
			0	Disabled (default)		

			1	Enable			
			6	Transmission mode			During fixed-point transmission, the module will identify the first three bytes of serial port data as: address high + address low + channel, and use them as wireless transmission targets.
			0	Transparent transmission (default)			
			1	Fixed point transmission			After the repeater function is enabled, if the target address is not the module itself, the module will start a forwarding ; In order to prevent data from being transmitted back, it is recommended to use it in conjunction with fixed-point mode ; that is, the destination address and source address are different.
			5	Repeater function			
			0	Disable repeater functionality (default)			When enabled, wireless data will be monitored before transmission, which can avoid interference to a certain extent, but may cause data delays;
			1	Enable repeater function			
			4	LBT Enable			The maximum dwell time of LBT is 2 seconds. The wireless data will be transmitted forcibly after 2 seconds.
			0	Disabled (default)			
			1	Enable			Below operation is valid for Mode 1 only;
			3	WOR mode transmission control			
			0	WOR receiver (default) Working in WOR listening mode, the listening period is shown below (WOR period), which can save a lot of power consumption.			In WOR receiving mode (as WOR receiver), the delay time after wake-up can be modified. The default time is 0; 1. To modify the delay time after wake-up, WOR receiver needs to send the command C0 09 02 03 E8 in the configuration mode (C0 is writing command, 09 is the starting address of the register, 02 is the length, 03 E8 is the set delay, the maximum delay FFFF is 65535ms, if the delay is set to 0, the wake-up delay is turn off.)
			1	WOR transmitter The module receiving and transmitting functions are turned on, and a wake-up code of a period of time is added when transmitting data.			
			2	1	0	WOR cycle time	Below description is valid for Mode 1 only; Cycle time $T = (1 + WOR) * 500ms$, max.4000ms, min.500ms; The longer the cycle time T (WOR listening interval period), the lower the average power consumption, but the greater the data delay. Both the transmitter and the receiver must be set as the same cycle time T (very important).
			0	0	0	500ms	
			0	0	1	1000ms	
			0	1	0	1500ms	
			0	1	1	2000ms	
			1	0	0	2500ms	
			1	0	1	3000ms	
			1	1	0	3500ms	
			1	1	1	4000ms	
07H	Write	CRYPT_H	High byte of Key (default 0)				
08H	Write	CRYPT_L	Low byte of Key (default 0)				Used for encryption to avoid interception of wireless data in the air by similar modules; The module will internally use these two bytes as a calculation factor to do a transform encryption processing for the wireless signal over the air.
80H ~ 86H	Read	PID	Product information 7 bytes				Product information 7 bytes

7.3 Factory Default Parameters

model	Factory default parameter value: C0 00 09 00 00 00 62 00 12 03 00 00						
Module model	frequency	address	channel	air speed	baud rate	Serial format	transmit power
E22-900T33S	868.125MHz	0x0000	0x12	2.4kbps	9600	8N1	33 dbm

8. AT command

- Parameter configuration or query using AT commands needs to be done in configuration mode;
- AT commands are used in configuration mode. AT commands are divided into three categories: command commands, setting commands and query commands;
- Users can query the AT command set supported by the module through "AT+HELP=?". The baud rate used by the AT command is 9600 8N1;
- When the input parameters exceed the range, they will be restricted. Please do not let the parameters exceed the range to avoid unknown situations.

8.1 AT command list

Command Commands	Description	Example	Example description
AT+IAP (use with caution, please see 8.3 Precautions for Serial Port Firmware Upgrade in this article for details .)	Enter IAP upgrade mode	AT+IAP	Enter IAP upgrade mode
AT+RESET	Device restart	AT+RESET	Device restart
AT+DEFAULT	Restore configuration parameters to default and the device restarts	AT+DEFAULT	Restore configuration parameters to default and the device restarts

Setting Commands	Description	Example	Example description
AT+UART=baud,parity	Set baud rate and parity	AT+UART=3,0	Set the baud rate to 9600, 8N1
AT+RATE=rate	Set air data rate	AT+RATE=7	Set air data rate to 62.5K
AT+PACKET=packet	Set packet length	AT+PACKET=0	Set the packet size to 240 bytes
AT+WOR=role	Set WOR role	AT+WOR=0	Set to WOR reception
AT+POWER=power	Set transmit power	AT+POWER=0	Set the transmit power to 33dBm
AT+TRANS=mode	Set transmission mode	AT+TRANS=1	Set to fixed point transmission mode
AT+ROUTER=router	Set repeater mode	AT+ROUTER=1	Set to repeater mode
AT+LBT=lbt	Set Listen Before Talk function switch	AT+LBT=1	Setting is enabled, please refer to Section 7.2 LBT Enable for details.
AT+ERSSI=erssi	Set the environmental noise RSSI switch	AT+ERSSI=1	The setting is enabled. For details, please refer to Section 7.2 RSSI environmental Noise Function.
AT+DRSSI=data_rssi	Set the receive data RSSI switch	AT+DRSSI=1	Receive data RSSI function is turned on
AT+ADDR=addr	Set module address	AT+ADDR=1234	Set the module address to 1234
AT+CHANNEL=channel	Set module working	AT+CHANNEL=23	Set frequency to 868.125M

	channel		
AT+NETID=netid	Set network ID	AT+NETID=2	Set network ID to 2
AT+KEY=key	Set module key	AT+KEY=1234	Set the module key to 1234
AT+DELAY=delay	Set WOR delay sleep time	AT+DELAY=1000	Set the WOR delay sleep time to 1000ms
AT+SWITCH=switch	Setting software mode switch	AT+SWITCH=1	Enable settings in configuration mode to allow software switching
AT+MODE=mode	Switch working mode	AT+MODE=0	Switch to transparent transmission mode
Setting Commands	Description	Example	Example description

Query Commands	Description	Return example	Example description
AT+HELP=?	Query AT command table		Return to AT command list
AT+DEVTYPE=?	Query module model	DEVTYPE=E22 -900T33S	Return module model
AT+FWCODE=?	Query firmware code	FWCODE=7432-0-10	Return firmware version
AT+UART=?	Query baud rate and checksum	AT+UART=3,0	Return baud rate 9600, 8N1
AT+RATE=?	Query air speed	AT+RATE=7	Return air rate is 62.5K
AT+PACKET=?	Query packet length	AT+PACKET=0	The returned packet is 240 bytes
AT+WOR=?	Query WOR roles and cycles	AT+WOR=0	Return as WOR receiver
AT+POWER=?	Query transmit power	AT+POWER=0	The return transmit power is 22dBm
AT+TRANS=?	Query sending mode	AT+TRANS=1	Return to fixed point mode
AT+ROUTER=?	Query relay mode	AT+ROUTER=1	Return to relay mode
AT+LBT=?	Query the Listen Before Talk function switch	AT+LBT=1	Return LBT switch status
AT+ERSSI=?	Query the environmental noise RSSI switch	AT+ERSSI=1	Return to environmental noise switch status
AT+DRSSI=?	Query RSSI output	AT+DRSSI=1	Return channel RSSI function is enabled
AT+ADDR=?	Query module address	AT+ADDR=1234	The return module address is 1234
AT+CHANNEL=?	Query module working channel	AT+CHANNEL=23	The return frequency is 868.125M
AT+NETID=?	Query network ID	AT+NETID=2	Return network ID is 2
AT+KEY=?	Query module key	Reading is not supported (security considerations)	Return ERR
AT+DELAY=?	Query WOR delayed sleep time	AT+DELAY=1000	Return to WOR delayed sleep time is 1000ms
AT+SWITCH=?	Query software switching mode switch	AT+SWITCH=0	Software switching mode is off

AT+MODE=?	Query the current working mode (can be queried in all modes)	AT+MODE=0	Returns the current transparent transmission mode
-----------	--	-----------	---

8.2 AT parameter analysis

When the serial port receives the correct command, the serial port will return "command=OK", otherwise it will return "=ERR"

Command parameters	Parameter meaning
Baud (serial port baud rate)	0:1200 1:2400 2:4800 3:9600 4:19200 5:38400 6 : 57600 7:115200
Parity (serial port parity bit)	0:8N1 1:8O1 2:8E1 3:8N1
Rate (over-the-air data rate)	0:2.4K 1:2.4K 2:2.4K 3:4.8K 4:9.6K 5:19.2K 6:38.4K 7:62.5K
Packet (packet length)	0: 240 1: 128 2:64 3:32
Role (WOR role)	0: Receiving 1: Transmitting
Period (WOR period)	0:500ms 1:1000ms 2:1500ms 3:2000ms 4:2500ms 5:3000ms 6:3500ms 7:4000ms
Power (transmit power)	0: 33dBm 1: 30dBm 2: 27dBm 3: 24dBm
Mode (transmission mode)	0: transparent 1: fixed point
Router (repeater mode)	0: Close 1: Open
LBT(listen before talk)	0: Close 1: Open
Erssi (environment RSSI)	0: Close 1: Open
Data_rssi (data RSSI)	0: Close 1: Open
Addr (module address)	Module address 0~65535 (decimal)
Channel (module channel)	Module channel 0~80 (decimal)
Netid (Network ID)	Module network 0~255 (decimal)
Key	Module key 0~65535 (decimal)
Delay (WOR delayed sleep)	Delayed sleep 0~65535 (decimal)
SWITCH (Software switching mode switch)	0: Close 1: Open
Mode(working mode)	0: Transparent transmission mode 1: WOR mode 2: Configuration mode

8.3 Notes for upgrading firmware via serial port

If the customer needs to upgrade the firmware, they need to find the corresponding BIN file provided by the official, and then use the officially provided host computer to upgrade the firmware. Generally, when users do not need to upgrade the firmware, please do not use the "AT+IAP" command.

The pins necessary for the upgrade must be lead out (M1, M0, AUX, TXD, RXD, VCC, GND), and then send the "AT+IAP" command in the configuration mode to enter the upgrade mode. **If you need to exit the IAP upgrade mode, you need to keep Power on and wait 60 seconds, the program will automatically exit, otherwise it will enter the upgrade mode indefinitely even if it is restarted.**

After entering the upgrade mode, the baud rate will automatically switch to 115200 until it automatically exits, during which there will be log output.

9 Use of relay networking mode

serial number	Description of relay mode
1	After setting the relay mode through the configuration mode, switch to the general mode and the relay starts to work.
2	In the repeater mode, ADDH and ADDL are no longer used as module addresses, but correspond to NETID forwarding pairs respectively. If one of the networks is received, it will be forwarded to another network ; The repeater's own network ID is invalid.
3	In relay mode, the relay module cannot send and receive data, and cannot operate with low power consumption.
4	When the user enters other modes from mode 3 (sleep mode) or during the reset process, the module will reset the user parameters, during which AUX outputs low level.

Relay networking rules description:

- 1、 Forwarding rules, the relay can bidirectionally forward data between two NETIDs.
- 2、 In relay mode, ADDH\ADDL is no longer used as a module address, but as a NETID forwarding pair.

As shown in the picture:

①relay

"Node 1" has a NETID of 08.

"Node 2" has a NETID of 33.

The ADDH\ADDL of trunk 1 are 08 and 33 respectively.

So the signal sent by node 1(08) can be forwarded to node 2 (33)

At the same time, node 1 and node 2 have the same address, so the data sent by node 1 can be received by node 2.

② Secondary relay

The ADDH\ADDL of relay 2 are 33 and 05 respectively.

So relay 2 can forward the data of relay 1 to network NETID:05.

Thus node 3 and node 4 can receive node 1 data. Node 4 outputs data normally, and node 3 has a different address from node 1, so no data is output.

③ Two -way relay

Configuration as shown in the figure: the data sent by node 1 can be received by nodes 2 and 4, and the data sent by nodes 2 and 4 can also be received by node 1.

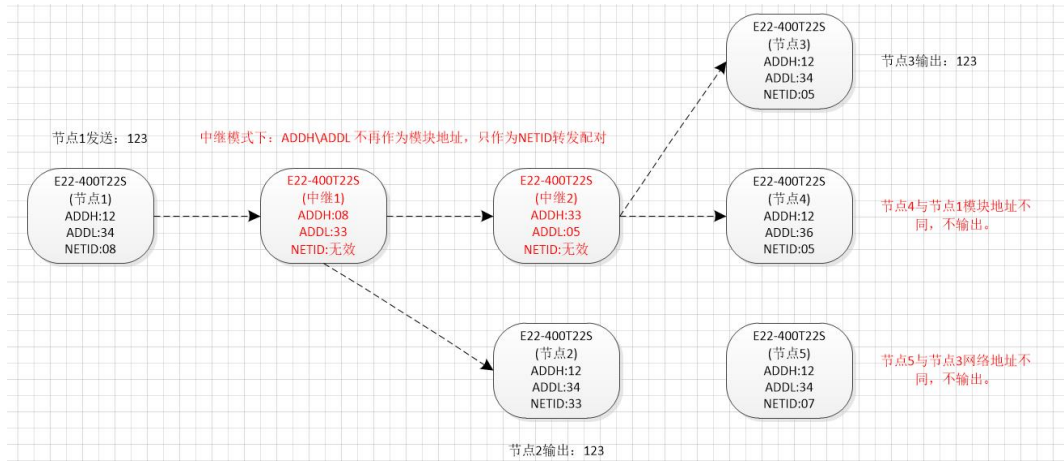

10 PC Configuration Instructions

- The figure below shows the display interface of the E22-900T33S configuration upper computer. The user can switch to the command mode through M0 and M1, and quickly configure and read parameters on the upper computer.



- In the configuration host computer, the module address, frequency channel, network ID, and key are all in decimal display mode; the value range of each parameter:

Network address: 0~65535

Frequency channel: 0~80

Network ID: 0~255

Key: 0~65535

- When using the host computer to configure the relay mode, the user needs to pay special attention. Since the parameters in the host computer are in decimal display mode, the module address and network ID need to be converted to decimal when filling in;

For example, if the network ID input by transmitter A is 02, and the network ID input by receiver B is 10, then when the relay terminal R sets the module address, convert the hexadecimal value 0X020A to the decimal value 522 and fill it in as the relay terminal R module address;

That is to say, the module address value that the relay terminal R needs to fill in at this time is 522.

11 Hardware Design

- It is recommended to use a DC regulated power supply to power the module, the power supply ripple factor should be as small as possible, and the module must be reliably grounded;
- Please pay attention to the correct connection of the positive and negative poles of the power supply, such as reverse connection may cause permanent damage to the module;
- Please check the power supply to ensure that it is between the recommended power supply voltage, if it exceeds the maximum value, it will cause permanent damage to the module;
- Please check the stability of the power supply, the voltage cannot fluctuate greatly and frequently;
- When designing the power supply circuit for the module, it is often recommended to reserve more than 30% of the margin, and the whole machine is conducive to long-term stable work;
- The module should be kept as far away as possible from parts with high electromagnetic interference such as power supplies, transformers, and high-frequency wiring;
- High-frequency digital traces, high-frequency analog traces, and power traces must avoid the bottom of the module. If it is really necessary to pass through the bottom of the module, assuming that the module is soldered to the Top Layer, lay copper on the top layer of the contact part of the module (all copper and Good grounding), must be close to the digital part of the module and routed in the Bottom Layer ;
- Assuming that the module is soldered or placed on the Top Layer, it is also wrong to randomly route the wires on the Bottom Layer or other layers, which will affect the stray and receiving sensitivity of the module to varying degrees ;
- Assuming that there are devices with large electromagnetic interference around the module, which will greatly affect the performance of the module, it is recommended to keep away from the module according to the intensity of the interference, and if the situation permits, proper isolation and shielding can be done;
- Assuming that there are traces with large electromagnetic interference around the module (high-frequency digital, high-frequency analog, power supply traces) will also greatly affect the performance of the module. According to the intensity of the interference, it is recommended to keep away from the module. If the situation permits, you can do it appropriately isolation and shielding;
- If the communication line uses a 5V level, a 1k-5.1k resistor must be connected in series (not recommended, there is still a risk of damage) ;
- Try to stay away from some TTL protocols whose physical layer is also 2.4GHz, for example: USB3.0;
- The antenna installation structure has a great impact on the performance of the module, so make sure that the antenna is exposed and preferably vertically upward;
- When the module is installed inside the casing, a high-quality antenna extension cable can be used to extend the antenna to the outside of the casing;
- The antenna must not be installed inside the metal shell, which will greatly weaken the transmission distance.

12 Frequently Asked Questions

12.1 The transmission distance is not ideal

- When there is a straight-line communication obstacle, the communication distance will be attenuated accordingly ;
- Temperature, humidity, and co-channel interference will increase the communication packet loss rate ;
- The ground absorbs and reflects radio waves, and the test effect is poor when it is close to the ground ;
- Seawater has a strong ability to absorb radio waves, so the seaside test results are poor ;
- There are metal objects near the antenna, or placed in a metal case, the signal attenuation will be very serious ;
- The power register is set incorrectly, and the air speed is set too high (the higher the air speed, the closer the distance) ;
- The low voltage of the power supply at room temperature is lower than the recommended value, and the lower the voltage, the lower the output power ;
- The matching degree between the antenna and the module is poor or the quality of the antenna itself is problematic.

12.2 The module is easily damaged

- Please check the power supply to ensure that it is between the recommended power supply voltage, if it exceeds the maximum value, it will cause permanent damage to the module ;
- Please check the stability of the power supply, the voltage cannot fluctuate greatly and frequently ;
- Please ensure anti-static operation during installation and use, and high-frequency devices are electrostatically sensitive ;
- Please ensure that the humidity during installation and use should not be too high, some components are humidity sensitive devices ;
- If there is no special requirement, it is not recommended to use it at too high or too low temperature.

12.3 bit error rate is too high

- There is co-channel signal interference nearby, stay away from the source of interference or modify the frequency and channel to avoid interference;

- Unsatisfactory power supply may also cause garbled characters, so be sure to ensure the reliability of the power supply;
- Poor quality or too long extension lines and feeders will also cause high bit error rates.

13 Welding Operation Instructions

13.1 Reflow soldering temperature

Profile Features	curve feature	Sn-Pb Assembly	Pb-Free Assembly
Solder Paste	Solder paste	Sn63/Pb37	Sn96.5/Ag3/Cu0.5
Preheat Temperature min (T _{smin})	Minimum preheat temperature	100 °C	150 °C
Preheat temperature max (T _{smax})	maximum preheating temperature	150 °C	200 °C
Preheat Time (T _{smin} to T _{smax})(ts)	Preheat time	60-120sec	60-120sec
Average ramp-up rate(T _{smax} to T _p)	average rate of ascent	3 °C /second max	3 °C /second max
Liquid Temperature (TL)	liquidus temperature	183 °C	217 °C
Time (tL) Maintained Above (TL)	time above liquidus	60-90sec	30-90sec
Peak temperature (T _p)	peak temperature	220-235 °C	230-250 °C
Average ramp-down rate (T _p to T _{smax})	average rate of decline	6 °C /second max	6 °C /second max
Time 25 °C to peak temperature	25 °C to peak temperature	6 minutes max	8 minutes max

13.2 Reflow Soldering Curve

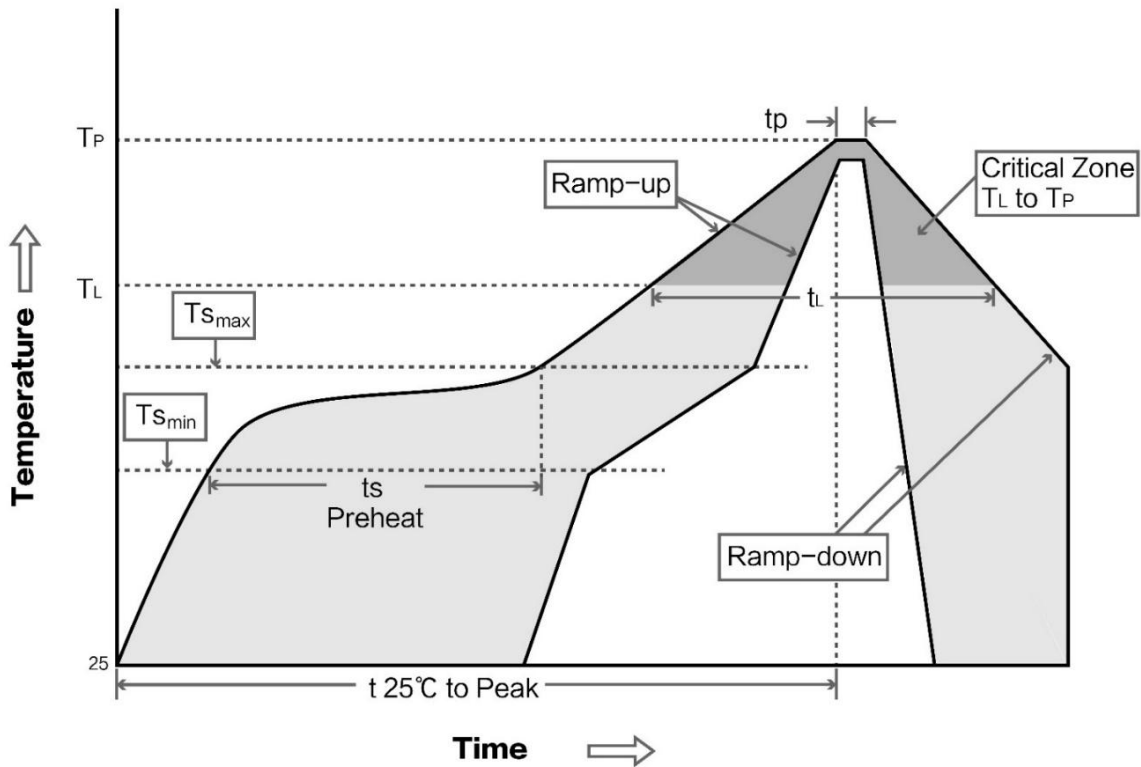

14 Related Models

Product number	carrier frequency Hz	transmit power dBm	Test distance km	Package form	Product Size mm	Communication Interface
E22-400T22S	433/470M	twenty two	5	patch	16*26	UART
E22-400T22D	433/470M	twenty two	5	in-line	21*36	UART
E22-400T30S	433/470M	30	10	patch	20*40.5	UART
E22-400T 30D	433/470M	30	10	in-line	24*43	UART
E22-9 00T22S	868 / 915M	twenty two	5	patch	16*26	UART
E22-9 00T22D	868 / 915M	twenty two	5	in-line	21*36	UART
E22-9 00T30S	868 / 915M	30	10	patch	20*40.5	UART
E22-9 00T 30 D	868 / 915M	30	10	in-line	24*43	UART

15 Antenna Guide

Antennas play an important role in the communication process, and often inferior antennas will have a great impact on the communication system. Therefore, our company recommends some antennas as antennas with excellent performance and reasonable price to match our wireless modules.

Product number	type	frequency Hz	interface	gain dBi	high m m	feeder c m	Features
TX 868 -JZ-5	Plastic Antenna	868M _	SMA-J	2.0 _	52	-	Ultra-short straight, omnidirectional antenna
TX 868 -JK-20	Plastic Antenna	868M _	SMA-J	3.0 _	210	-	Bendable Plastic, omnidirectional antenna
TX 868 -XP L -100	Suction cup antenna	868M _	SMA-J	3.5	290	100	Small suction cup antenna, high cost performance
TX 915 -JZ-5	Plastic Antenna	915M _	SMA-J	2.0	52	-	Ultra-short straight, omnidirectional antenna
T X915-JK-11	Plastic Antenna	915M _	SMA-J	2.5	110	-	Bendable Plastic, omnidirectional antenna
T X915-JK-20	Plastic Antenna	915M _	SMA-J	3.0 _	210	-	Bendable Plastic, omnidirectional antenna
TX 915 -XP L -100	Suction cup antenna	915M _	SMA-J	3.5	290	100	Small suction cup antenna, high cost performance

16 Batch Packaging Method

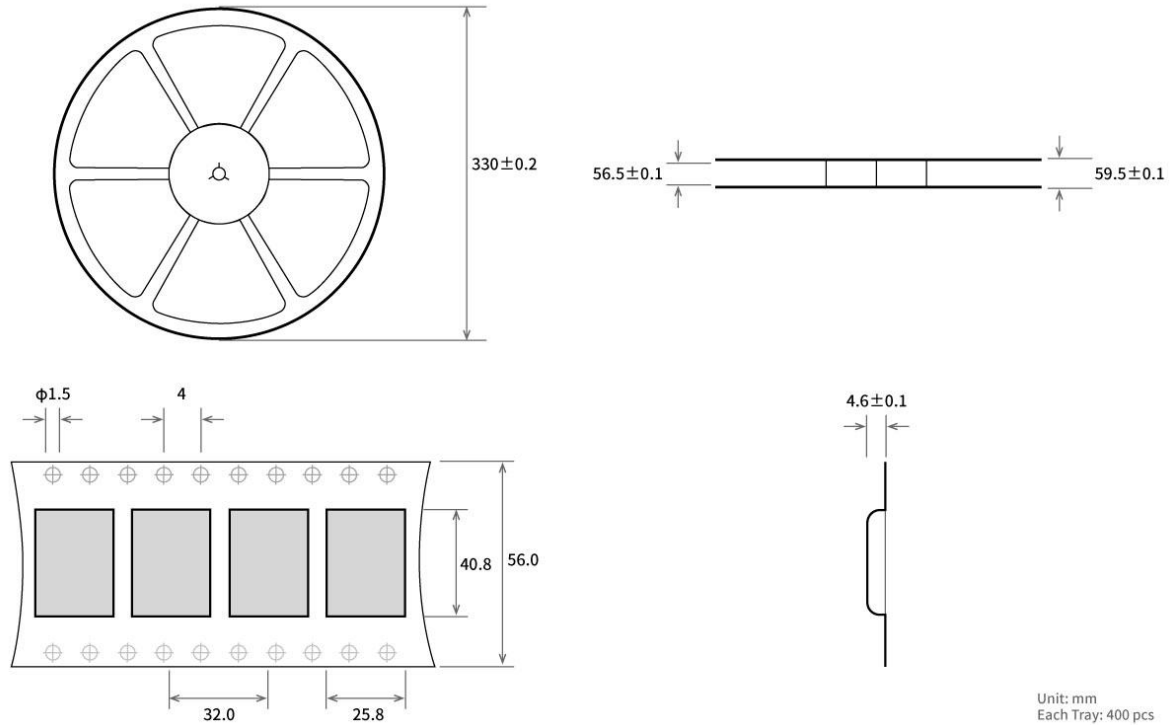

Revise History

Version	revision date	Revision Notes	Maintenance man
1.0	2023-6-6	initial version	Yan Yan
1.1	2024-1-9	Content correction	Hao
1.2	2024-4-16	Content correction	Hao
1.3	2024-8-30	Change power value	Hao

About US

Technical support: support@cdebyte.com

Documents and RF Setting download link: <https://www.cdebyte.com/>

Thank you for using Ebyte products! Please contact us with any questions or suggestions: info@cdebyte.com

Address: B5 Mould Industrial Park, 199# Xiqu Ave, High tech Zone, Chengdu, Sichuan, China



Chengdu Ebyte Electronic Technology Co.,Ltd.