

# MSKSEMI 美森科

SEMICONDUCTOR



ESD



TVS



TSS



MOV



GDT



PLED

## LD1117X-x.x(MS)

Product specification

## General Description

LD1117X-x.x(MS) is a series of low dropout three-terminal regulators with a dropout of 1.3V at 1A load current.

LD1117X-x.x(MS) features a very low standby current 2mA compared to 5mA of competitor.

Other than a fixed version,  $V_{out} = 1.2V, 1.5V, 1.8V, 2.5V, 2.85V, 3.3V,$  and  $5V$ , LD1117X-x.x(MS) has an adjustable version, which can provide an output voltage from 1.25 to 12V with only two external resistors.

LD1117X-x.x(MS) offers thermal shut down function, to assure the stability of chip and power system. And it uses trimming technique to guarantee output voltage accuracy within 2%. Other output voltage accuracy can be customized on demand, such as 1%.

LD1117X-x.x(MS) is available in SOT-223, TO-252 and SOT89 power package.

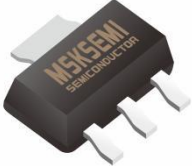

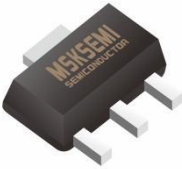
## Features

- Output current is 1A
- Range of operation input voltage: 15V
- Line regulation: 0.03%/V (typ.)
- Standby current: 2mA (typ.)
- Load regulation: 0.2%/A (typ.)
- Environment Temperature:  $-40^{\circ}C \sim 85^{\circ}C$

## Applications

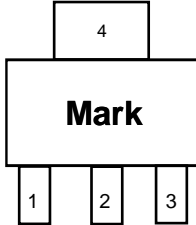
- Power Management for Computer Mother Board, Graphic Card
- LCD Monitor and LCD TV
- DVD Decode Board
- ADSL Modem
- Post Regulators for Switching Supplies

## Encapsulation form and pin definition function

PACKAGE OUTLINE	Marking
 <p>SOT-223</p>	<div data-bbox="1054 1491 1358 1671" style="background-color: black; color: white; padding: 10px; text-align: center;"> <p><b>LD1117</b> <b>1.2 MS**</b></p> </div> <p><b>Note:</b> 1.2 represents fixed voltage, * * represents internal production order number</p>
 <p>TO-252</p>	
 <p>SOT-89</p>	

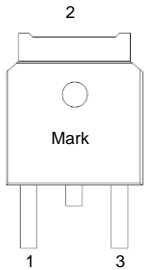
**Table1: ALM1117X-XXX(MS) series (SOT223 PKG)**

PIN NO.	PIN NAME	FUNCTION
1	VSS/ADJ	VSS/ADJ pin
2	VOUT	Output voltage pin
3	VIN	Input voltage pin
4	VOUT	Output voltage pin



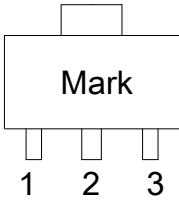
**Table2: LM1117X-XXX(MS) series (TO252 PKG)**

PIN NO.	PIN NAME	FUNCTION
1	VSS/ADJ	VSS/ADJ pin
2	VOUT	Output voltage pin
3	VIN	Input voltage pin

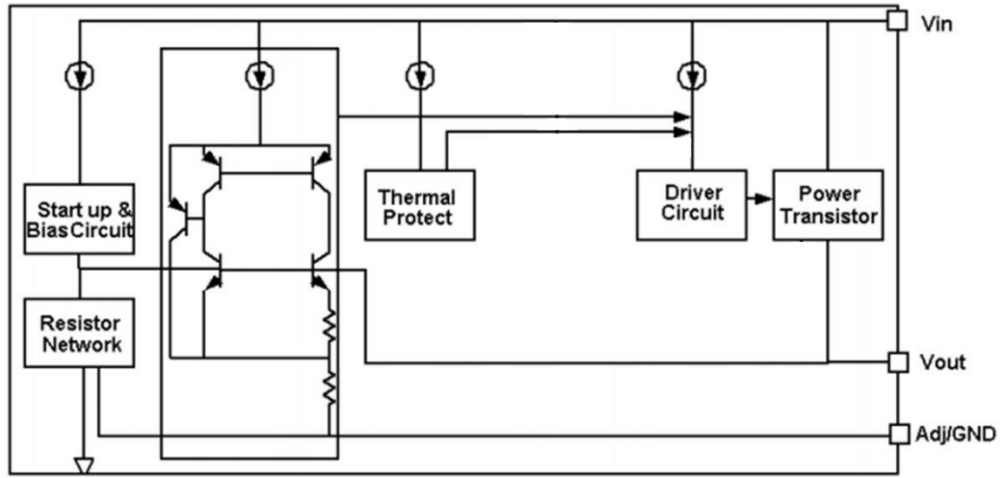


**Table3: LM1117CD-XXX(MS) series (SOT89 PKG)**

PIN NO.	PIN NAME	FUNCTION
1	VSS/ADJ	VSS/ADJ pin
2	VOUT	Output voltage pin
3	VIN	Input voltage pin



**Block Diagram**



**Selection Table**

Part No.	Part No.	Output Voltage	Package
LD1117X-x.x(MS)	X.X=12	1.2V	SOT-223 TO-252 SOT-89
	X.X=15	1.5V	
	X.X=18	1.8V	
	X.XX=285	2.85V	
	X.X=25	2.5V	
	X.X=33	3.3V	
	X.X=50	5.0V	
	XX=ADJ	ADJ	

**Ordering Information**

Part No.	Package Type	Packing type
LD1117F-x.x(MS)	SOT89	1000 Tape&Reel
LD1117S-x.x(MS)	SOT223	2500 Tape&Reel
LD1117-x.x(MS)	TO252	2500 Tape&Reel

**Note:** X . X stands for Output Voltage

## Absolute Maximum Ratings

Max Input Voltage ..... 18V  
 Max Operating Junction Temperature(Tj) ..... 150°C  
 Storage Temperature(Ts)..... -55°C~150°C  
 Lead Temperature & Time..... 260°C 10S  
 Caution: Exceed these limits to damage to the device. Exposure to absolute maximum rating conditions may affect device reliability.

## Electrical Characteristics

T<sub>A</sub>=25°C , unless otherwise noted.

Symbol	Parameter	Conditions	Min	Typ	Max	Unit
V <sub>in</sub>	Input voltage		--	15	18	V
V <sub>ref</sub>	Reference voltage	LD1117X-Adj 10mA ≤ I <sub>out</sub> ≤ 1A , V <sub>in</sub> =2.55V	1.225	1.25	1.275	V
V <sub>out</sub>	Output voltage	LD1117X-1.2V 0 ≤ I <sub>out</sub> ≤ 1A , V <sub>in</sub> =2.5V	1.176	1.2	1.224	V
		LD1117X-1.5V 0 ≤ I <sub>out</sub> ≤ 1A , V <sub>in</sub> =2.8V	1.47	1.5	1.53	V
		LD1117X-1.8V 0 ≤ I <sub>out</sub> ≤ 1A , V <sub>in</sub> =3.1V	1.764	1.8	1.836	V
		LD1117X-2.5V 0 ≤ I <sub>out</sub> ≤ 1A , V <sub>in</sub> =3.8V	2.45	2.5	2.55	V
		LD1117X-2.85V 0 ≤ I <sub>out</sub> ≤ 1A , V <sub>in</sub> =4.15V	2.793	2.85	2.907	V
		LD1117X-3.3V 0 ≤ I <sub>out</sub> ≤ 1A , V <sub>in</sub> =4.6V	3.234	3.3	3.366	V
		LD1117X-5.0V 0 ≤ I <sub>out</sub> ≤ 1A , V <sub>in</sub> =6.3V	4.9	5	5.1	V

ΔV <sub>out</sub>	Line regulation	LD1117X-1.2V I <sub>out</sub> =10mA, 2.5V ≤ V <sub>in</sub> ≤ 10V		4	19	mV
		LD1117X-1.5V I <sub>out</sub> =10mA, 2.8V ≤ V <sub>in</sub> ≤ 10V		5	26	mV
		LD1117X-ADJ I <sub>out</sub> =10mA, 2.55V ≤ V <sub>in</sub> ≤ 12V		5	24	mV
		LD1117X-1.8V I <sub>out</sub> =10mA, 3.1V ≤ V <sub>in</sub> ≤ 12V		5	32	mV
		LD1117X-2.5V I <sub>out</sub> =10mA, 3.8V ≤ V <sub>in</sub> ≤ 12V		8	41	mV
		LD1117X-2.85V I <sub>out</sub> =10mA, 4.15V ≤ V <sub>in</sub> ≤ 12V		8	46	mV
		LD1117X-3.3V I <sub>out</sub> =10mA, 4.6V ≤ V <sub>in</sub> ≤ 12V		9	49	mV
		LD1117X-5.0V I <sub>out</sub> =10mA, 6.3V ≤ V <sub>in</sub> ≤ 12V		10	56	mV

$\Delta V_{out}$	Load regulation	LD1117X-1.2V $V_{in} = 2.5V, 10mA \leq I_{out} \leq 1A$	10	40	mV
		LD1117X-1.5V $V_{in} = 2.8V, 10mA \leq I_{out} \leq 1A$	10	40	mV
		LD1117X-ADJ $V_{in} = 2.55V, 10mA \leq I_{out} \leq 1A$	10	40	mV
		LD1117X-1.8V $V_{in} = 3.1V, 10mA \leq I_{out} \leq 1A$	10	40	mV
		LD1117X-2.5V $V_{in} = 2.8V, 10mA \leq I_{out} \leq 1A$	10	40	mV
		LD1117X-2.85V $V_{in} = 4.15V, 10mA \leq I_{out} \leq 1A$	10	40	mV
		LD1117X-3.3V $V_{in} = 4.6V, 10mA \leq I_{out} \leq 1A$	10	40	mV
		LD1117X-5.0V $V_{in} = 6.3V, 10mA \leq I_{out} \leq 1A$	10	40	mV
Vdrop	Dropout voltage	$I_{out} = 100mA$	1.15	1.3	V
		$I_{out} = 1A$	1.3	1.5	V
Imin	Minimum load current	LD1117X-ADJ	2	10	mA
Iq	Quiescent Current	LD1117X-1.2V, $V_{in} = 10V$	2	5	mA
		LD1117X-1.5V, $V_{in} = 10V$	2	5	mA
		LD1117X-1.8V, $V_{in} = 12V$	2	5	mA
		LD1117X-2.5V, $V_{in} = 12V$	2	5	mA
		LD1117X, $V_{in} = 12V$	2	5	mA
		LD1117X, $V_{in} = 12V$	2	5	mA
		LD1117XL, $V_{in} = 12V$	2	5	mA
Iadj	Adjust pin current	LD1117X-ADJ $V_{in} = 5V, 10mA \leq I_{out} \leq 1A$	55	120	$\mu A$
Ichange	Iadj change	LD1117X-ADJ $V_{in} = 5V, 10mA \leq I_{out} \leq 1A$	0.2	10	$\mu A$

$\Delta V_{out}$	Temperature coefficient	$V_{in} = 4.5V, I_{out} = 10mA$ $V_{OUT} = 3.3V, 20^{\circ}C \leq T_a \leq 120^{\circ}C$	30		mV
$\theta_{JC}$	Thermal resistance	SOT-223	20		$^{\circ}C/W$
		TO-252	10		

**Note1:** All test are conducted under ambient temperature 25°C and within a short period of time 20ms

**Note2:** Load current smaller than minimum load current of LM1117-ADJ will lead to unstable or oscillation output.

## Detailed Description

LD1117X-x.x(MS) is a series of low dropout voltage, three terminal regulators. Its application circuit is very simple: the fixed version only needs two capacitors and the adjustable version only needs two resistors and two capacitors to work. It is composed of some modules including start-up circuit, bias circuit, bandgap, thermal shutdown, power transistors and its driver circuit and so on.

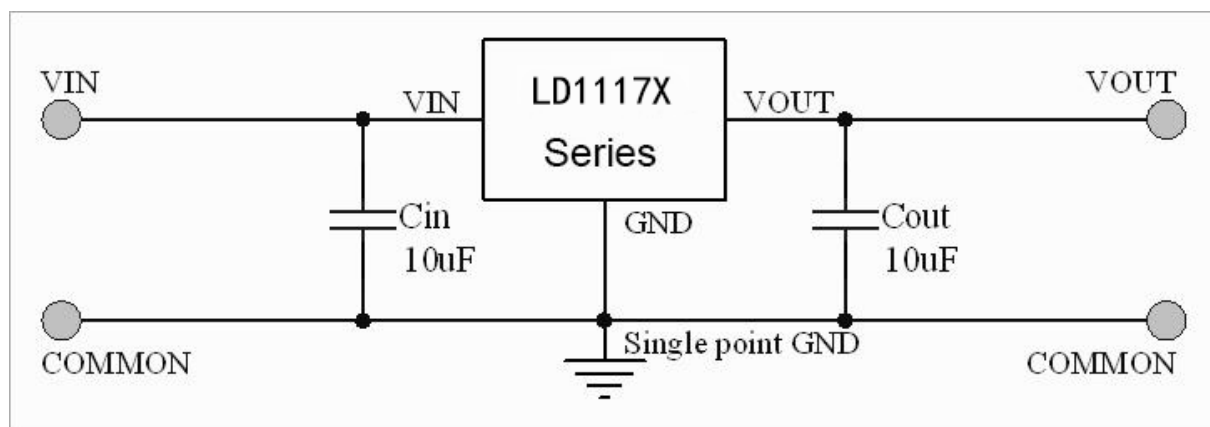
The thermal shut down modules can assure chip and its application system working safety when the temperature is larger than 170°C.

The bandgap module provides stable reference voltage, whose temperature coefficient is compensated by careful design considerations. The temperature coefficient is under 100 ppm/°C. And the accuracy of output voltage is guaranteed by trimming technique.

## Typical Application

LD1117X-x.x(MS) has an adjustable version and six fixed versions (1.2V, 1.5V, 1.8V, 2.5V, 2.85V, 3.3V and 5V)

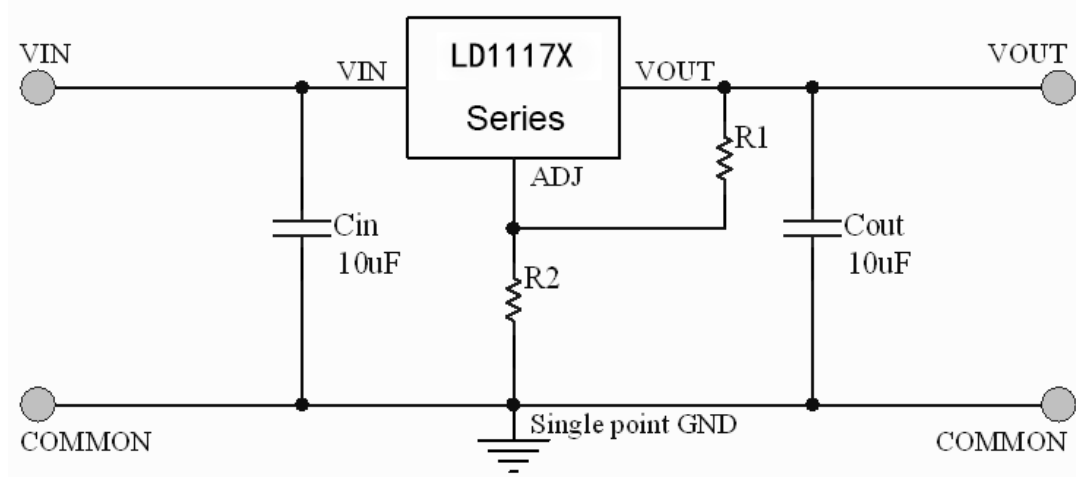
### Fixed Output Voltage Version



**Application circuit of LD1117X-x.x(MS) fixed version**

- (1) Recommend using 10uF tan capacitor as bypass capacitor (C1) for all application circuit.
- (2) Recommend using 10uF tan capacitor to assure circuit stability.

## Adjustable Output Voltage Version



Application Circuit of LD1117X-ADJ

The output voltage of adjustable version follows the equation:  $V_{out} = 1.25 \times (1 + R2/R1) + I_{Adj} \times R2$ . We can ignore  $I_{Adj}$  because  $I_{Adj}$  (about 50uA) is much less than the current of R1 (about 2~10mA).

1) To meet the minimum load current (>10mA) requirement, R1 is recommended to be 125ohm or lower. As LD1117X-ADJ can keep itself stable at load current about 2mA, R1 is not allowed to be higher than 625ohm.

2) Using a bypass capacitor ( $C_{ADJ}$ ) between the ADJ pin and ground can improve ripple rejection. This bypass capacitor prevents ripple from being amplified as the output voltage is increased. The impedance of  $C_{ADJ}$  should be less than R1 to prevent ripple from being amplified. As R1 is normally in the range of 100Ω~500Ω, the value of  $C_{ADJ}$  should satisfy this equation:  $1/(2\pi \times f_{ripple} \times C_{ADJ}) < R1$ .

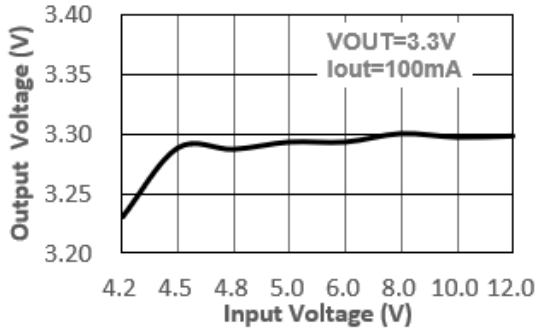
### Thermal Considerations

We have to take heat dissipation into great consideration when output current or differential voltage of input and output voltage is large. Because in such cases, the power dissipation consumed by LD1117X-x.x(MS) is very large. LD1117X-x.x(MS) series uses SOT-223 package type and its thermal resistance is about 20°C/W. And the copper area of application board can affect the total thermal resistance. If copper area is 5cm\*5cm (two sides), the resistance is about 30°C/W. So the total thermal resistance is about 20°C/W + 30°C/W. We can decrease total thermal resistance by increasing copper area in application board. When there is no good heat dissipation copper are in PCB, the total thermal resistance will be as high as 120°C/W, then the power dissipation of LD1117 could allow on itself is less than 1W. And furthermore, LD1117X-x.x(MS) will work at junction temperature higher than 125°C under such condition and no lifetime is guaranteed.

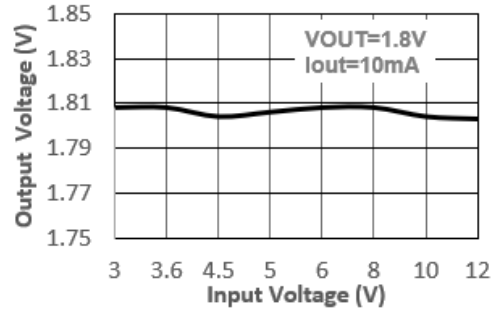
## Typical Performance Characteristics

T<sub>A</sub>=25°C, unless otherwise noted

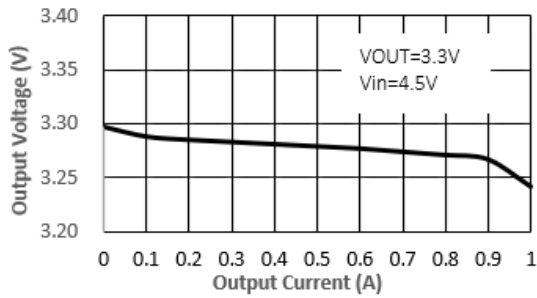
Output Voltage vs. Input Voltage (V<sub>OUT</sub>=3.3V)



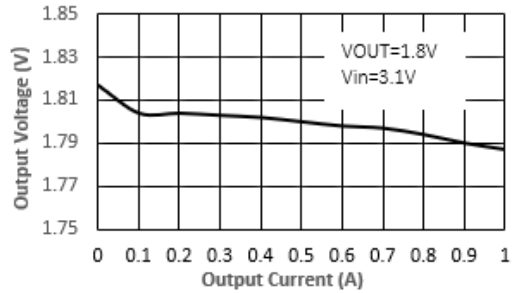
Output Voltage vs. Input Voltage (V<sub>OUT</sub>=1.8V)



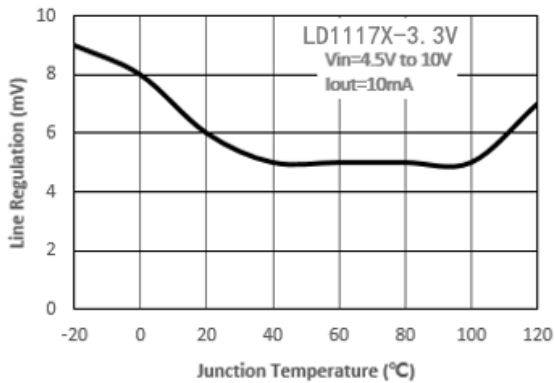
Output Voltage vs. Output Current (V<sub>OUT</sub>=3.3V)



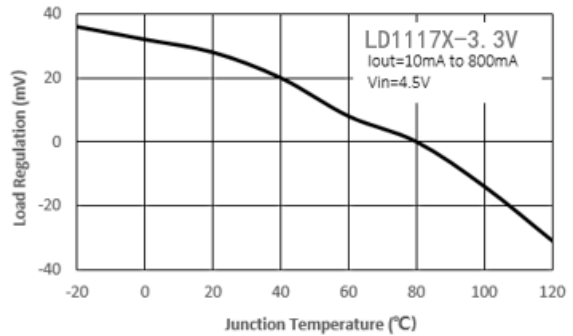
Output Voltage vs. Output Current (V<sub>OUT</sub>=1.8V)



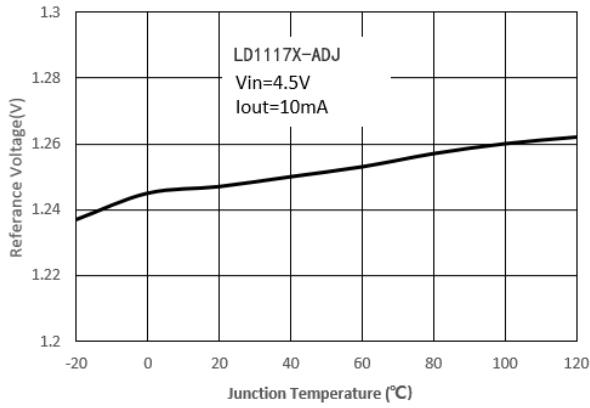
Line Regulation vs. Junction Temperature



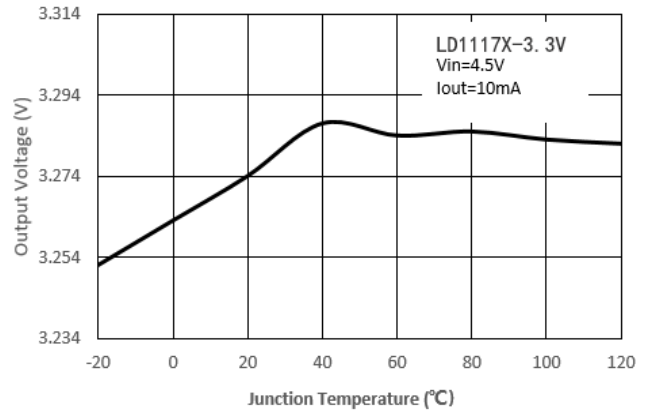
Load Regulation vs. Junction Temperature



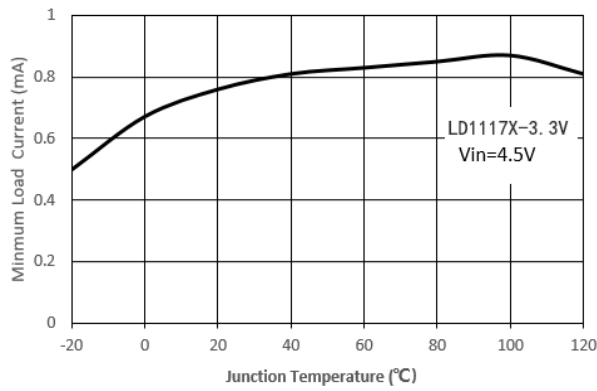
**Reference Voltage vs. Junction Temperature**



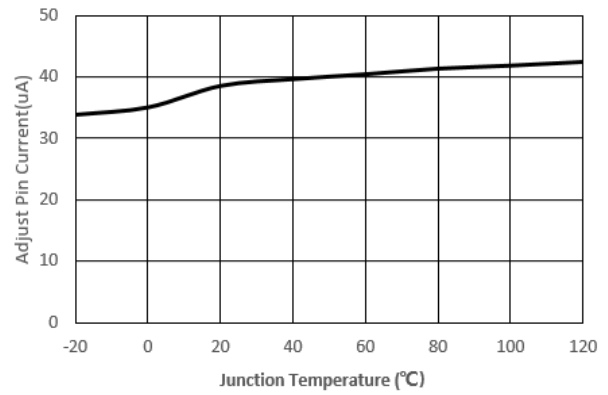
**Output Voltage vs. Junction Temperature**



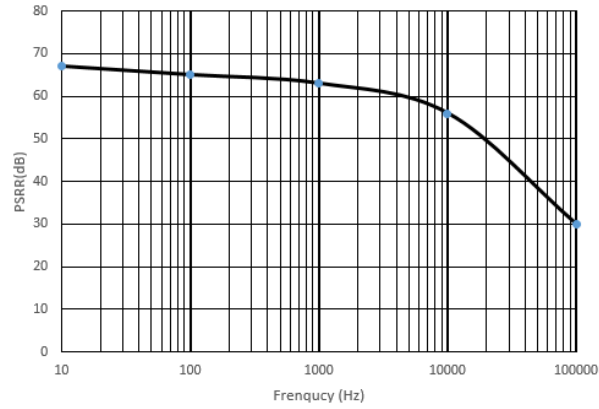
**Minimum Load Current vs. Junction Temperature**



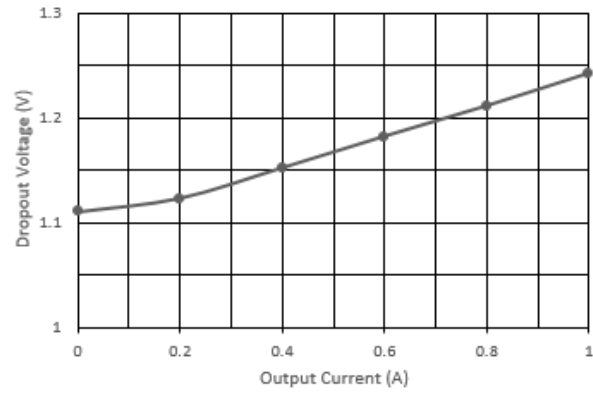
**Adjust Pin Current vs. Junction Temperature**



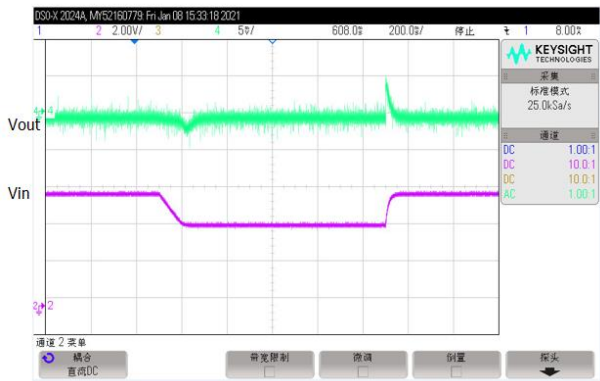
**PSRR vs. Frequency**



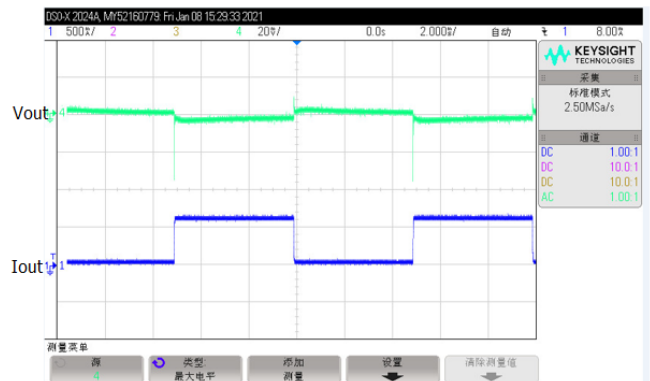
**Dropout Voltage vs. Output Current**



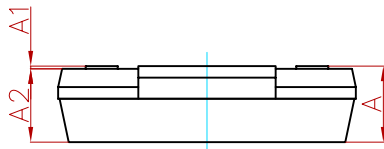
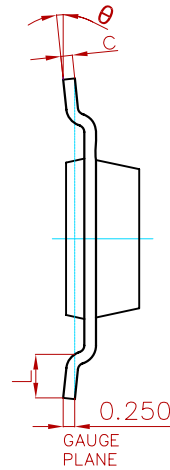
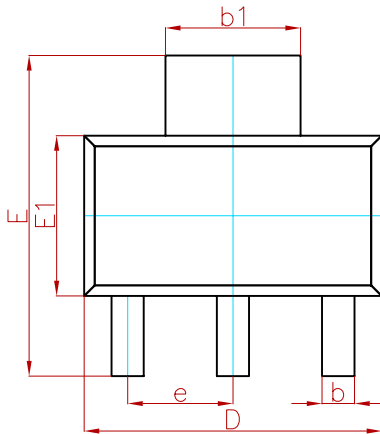
**Line Transient Response**



**Load Transient Response**

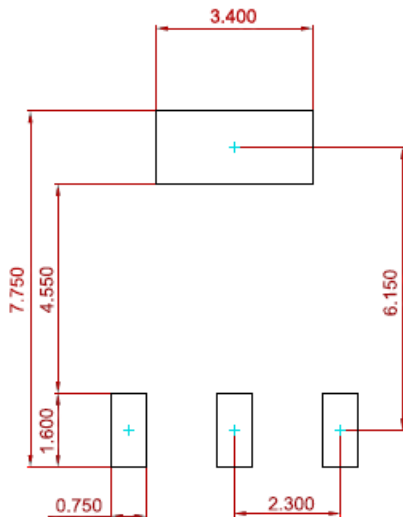


**SOT-223 PACKAGE MECHANICAL DATA**



Symbol	Dimensions In Millimeters		Dimensions In Inches	
	Min.	Max.	Min.	Max.
A	—	1.800	—	0.071
A1	0.020	0.100	0.001	0.004
A2	1.500	1.700	0.059	0.067
b	0.660	0.840	0.026	0.033
$b_1$	2.900	3.100	0.114	0.122
c	0.230	0.350	0.009	0.014
D	6.300	6.700	0.248	0.264
E	6.700	7.300	0.264	0.287
E1	3.300	3.700	0.130	0.146
e	2.300(BSC)		0.091(BSC)	
L	0.750	—	0.030	—
$\theta$	0°	10°	0°	10°

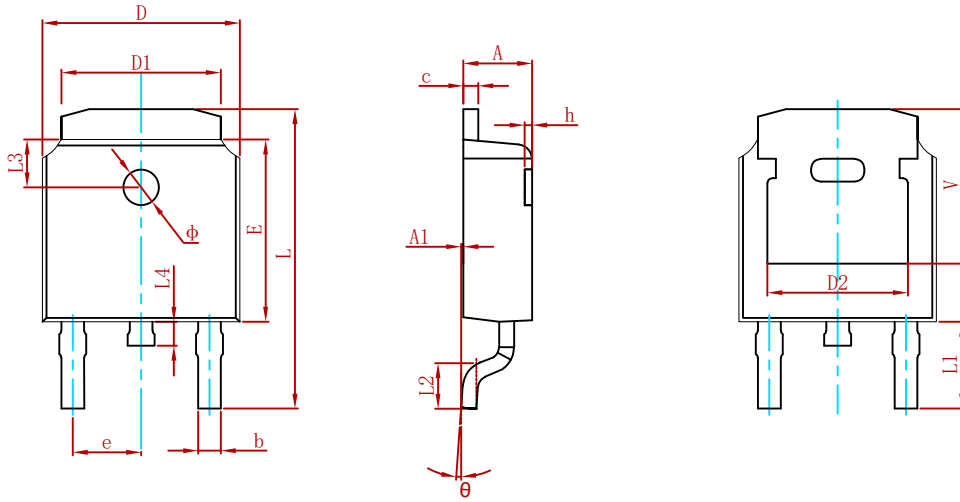
**Suggested Pad Layout**



**Note:**

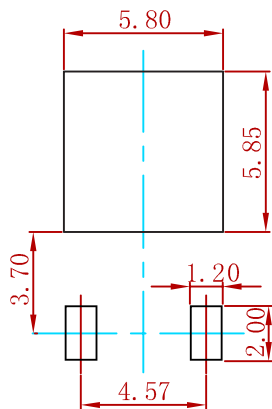
1. Controlling dimension: in millimeters.
2. General tolerance:  $\pm 0.050$  mm.
3. The pad layout is for reference purposes only.

**TO-252 PACKAGE MECHANICAL DATA**



Symbol	Dimensions In Millimeters		Dimensions In Inches	
	Min.	Max.	Min.	Max.
A	2.200	2.400	0.087	0.094
A1	0.000	0.127	0.000	0.005
b	0.635	0.770	0.025	0.030
c	0.460	0.580	0.018	0.023
D	6.500	6.700	0.256	0.264
D1	5.100	5.460	0.201	0.215
D2	4.830 REF.		0.190 REF.	
E	6.000	6.200	0.236	0.244
e	2.186	2.386	0.086	0.094
L	9.712	10.312	0.382	0.406
L1	2.900 REF.		0.114 REF.	
L2	1.400	1.700	0.055	0.067
L3	1.600 REF.		0.063 REF.	
L4	0.600	1.000	0.024	0.039
Φ	1.100	1.300	0.043	0.051
θ	0°	8°	0°	8°
h	0.000	0.300	0.000	0.012
V	5.250 REF.		0.207 REF.	

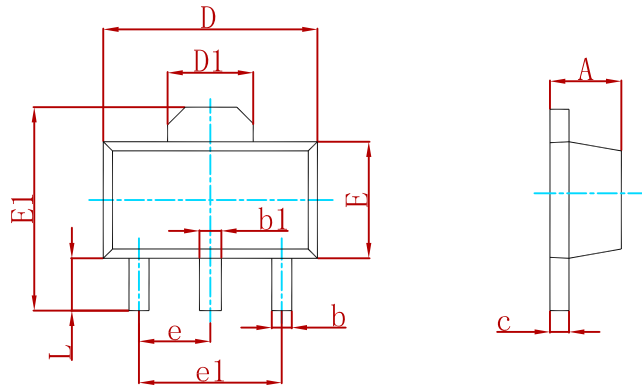
**Suggested Pad Layout**



**Note:**

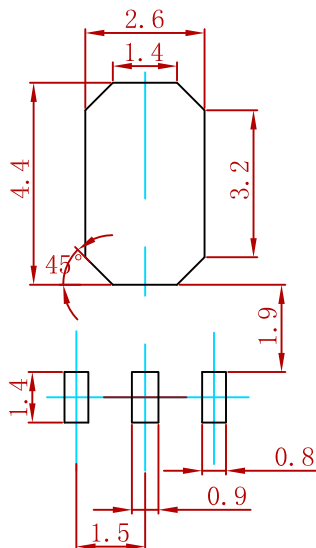
1. Controlling dimension: in millimeters.
2. General tolerance:  $\pm 0.05\text{mm}$ .
3. The pad layout is for reference purposes only.

**SOT-89 PACKAGE MECHANICAL DATA**



Symbol	Dimensions In Millimeters		Dimensions In Inches	
	Min	Max	Min	Max
A	1.400	1.600	0.055	0.063
b	0.320	0.520	0.013	0.020
b1	0.400	0.580	0.016	0.023
c	0.350	0.440	0.014	0.017
D	4.400	4.600	0.173	0.181
D1	1.550 REF.		0.061 REF.	
E	2.300	2.600	0.091	0.102
E1	3.940	4.250	0.155	0.167
e	1.500 TYP.		0.060 TYP.	
e1	3.000 TYP.		0.118 TYP.	
L	0.900	1.200	0.035	0.047

**Suggested Pad Layout**



- Note:
1. Controlling dimension: in millimeters.
  2. General tolerance:  $\pm 0.05$  mm.
  3. The pad layout is for reference purposes only.

## Attention

- Any and all MSKSEMI Semiconductor products described or contained herein do not have specifications that can handle applications that require extremely high levels of reliability, such as life-support systems, aircraft's control systems, or other applications whose failure can be reasonably expected to result in serious physical and/or material damage. Consult with your MSKSEMI Semiconductor representative nearest you before using any MSKSEMI Semiconductor products described or contained herein in such applications.
- MSKSEMI Semiconductor assumes no responsibility for equipment failures that result from using products at values that exceed, even momentarily, rated values (such as maximum ratings, operating condition ranges, or other parameters) listed in products specifications of any and all MSKSEMI Semiconductor products described or contained herein.
- Specifications of any and all MSKSEMI Semiconductor products described or contained herein stipulate the performance, characteristics, and functions of the described products in the independent state, and are not guarantees of the performance, characteristics, and functions of the described products as mounted in the customer's products or equipment. To verify symptoms and states that cannot be evaluated in an independent device, the customer should always evaluate and test devices mounted in the customer's products or equipment.
- MSKSEMI Semiconductor strives to supply high-quality high-reliability products. However, any and all semiconductor products fail with some probability. It is possible that these probabilistic failures could give rise to accidents or events that could endanger human lives, that could give rise to smoke or fire, or that could cause damage to other property. When designing equipment, adopt safety measures so that these kinds of accidents or events cannot occur. Such measures include but are not limited to protective circuits and error prevention circuits for safe design, redundant design, and structural design.
- In the event that any or all MSKSEMI Semiconductor products (including technical data, services) described or contained herein are controlled under any of applicable local export control laws and regulations, such products must not be exported without obtaining the export license from the authorities concerned in accordance with the above law.
- No part of this publication may be reproduced or transmitted in any form or by any means, electronic or mechanical, including photocopying and recording, or any information storage or retrieval system, or otherwise, without the prior written permission of MSKSEMI Semiconductor.
- Information (including circuit diagrams and circuit parameters) herein is for example only; it is not guaranteed for volume production. MSKSEMI Semiconductor believes information herein is accurate and reliable, but no guarantees are made or implied regarding its use or any infringements of intellectual property rights or other rights of third parties.
- Any and all information described or contained herein are subject to change without notice due to product/technology improvement, etc. When designing equipment, refer to the "Delivery Specification" for the MSKSEMI Semiconductor product that you intend to use.