

High-performance 480 MHz Arm® Cortex®-M85 core with Helium™, up to 2 MB code flash memory with Dual-bank, background and SWAP operation, 12 KB Data flash memory, and 1 MB SRAM with Parity/ECC. High-integration with Ethernet MAC controller, USB 2.0 High-Speed, CANFD, SDHI, I3C, Octal SPI, Decryption on-the-fly, Graphics LCD Controller, 2D Drawing Engine, MIPI DSI and advanced analog. Integrated Renesas Secure IP with cryptography accelerators, key management support, tamper detection and power analysis resistance in concert with Arm® TrustZone for integrated secure element functionality.

Features

- **Arm® Cortex®-M85 core with Helium™**
 - Armv8.1-M architecture profile
 - Armv8-M Security Extension
 - Maximum operating frequency: 480 MHz
 - Memory Protection Unit (Arm MPU)
 - Protected Memory System Architecture (PMSAv8)
 - Secure MPU (MPU_S): 8 regions
 - Non-secure MPU (MPU_NS): 8 regions
 - SysTick timer
 - Embeds two SysTick timers: Secure and Non-secure instance
 - Driven by CPUCLOCK or MOCO divided by 8
 - CoreSight™ ETM-M85
- **Memory**
 - Up to 2 MB code flash memory
 - 12 KB data flash memory (100,000 program/erase (P/E) cycles)
 - 1 MB SRAM including 128 KB of TCM
- **Connectivity**
 - Serial Communications Interface (SCI) × 6, up to 60 Mbps
 - Asynchronous interfaces
 - 8 bit clock synchronous interface
 - Smart card interface
 - Simple IIC
 - Simple SPI
 - Manchester coding (SCI0)
 - Simple LIN (SCI0, SCI1)
 - I²C bus interface (IIC) × 2
 - I³C bus interface (I3C)
 - Serial Peripheral Interface (SPI) × 2, up to 60 Mbps
 - Octal Serial Peripheral Interface (OSPI)
 - USB 2.0 Full-Speed Module (USBFS)
 - USB 2.0 High-Speed Module (USBHS)
 - CAN with Flexible Data-rate (CANFD) × 2
 - Ethernet MAC/DMA Controller (ETHERC/EDMAC)
 - SD/MMC Host Interface (SDHI) × 2
 - Serial Sound Interface Enhanced (SSIE) × 2
- **Analog**
 - 12-bit A/D Converter (ADC12) × 2
 - 12-bit D/A Converter (DAC12) × 2
 - High-Speed Analog Comparator (ACMPHS) × 2
 - Temperature Sensor (TSN)
- **Timers**
 - General PWM Timer 32-bit (GPT32) × 8
 - General PWM Timer 16-bit (GPT16) × 6
 - Low Power Asynchronous General Purpose Timer (AGT) × 2
 - Ultra-Low-Power Timer (ULPT) × 2
- **Security and Encryption**
 - Renesas Secure IP (RSIP-E51A)
 - Symmetric cryptography: AES
 - Asymmetric cryptography: RSA, ECC
 - Message digest computation: HASH
 - 128 bit unique ID
 - Arm® TrustZone®
 - Up to two or four regions for the code flash, depending on the bank mode
 - Up to two regions for the data flash
 - Up to two regions for the SRAM
 - Individual Secure or Non-secure security attribution for each peripheral
 - Privileged control
 - Device lifecycle management
 - Secure boot
 - Decryption on-the-fly (DOTF)
- Pin function
 - Up to three tamper-resistant pins
 - Secure pin multiplexing
- **System and Power Management**
 - Low power modes
 - Battery backup function (VBATT)
 - Realtime Clock (RTC) with calendar and VBATT support
 - Event Link Controller (ELC)
 - Data Transfer Controller (DTC)
 - DMA Controller (DMAC) × 8
 - Power-on reset
 - Programmable Voltage Detection (PVD) with voltage settings
 - Watchdog Timer (WDT)
 - Independent Watchdog Timer (IWDT)
- **Human Machine Interface (HMI)**
 - Graphics LCD Controller (GLCDC)
 - 2D Drawing Engine (DRW)
 - Capture Engine Unit (CEU)
 - MIPI DSI
- **Multiple Clock Sources**
 - Main clock oscillator (MOSC) (8 to 48 MHz)
 - Sub-clock oscillator (SOSC) (32.768 kHz)
 - High-speed on-chip oscillator (HOCO) (16/18/20/32/48 MHz)
 - Middle-speed on-chip oscillator (MOCO) (8 MHz)
 - Low-speed on-chip oscillator (LOCO) (32.768 kHz)
 - Clock trim function for HOCO/MOCO/LOCO
 - PLL1/PLL2
 - Clock out support
- **General-Purpose I/O Ports**
 - 5-V tolerance, open drain, input pull-up, switchable driving ability
- **Operating Voltage**
 - VCC: 1.68 to 3.6 V
 - VCC2: 1.65 to 3.6 V
- **Operating Junction Temperature and Packages**
 - T_j = -40°C to +125°C
 - 176-pin LQFP (24 mm × 24 mm, 0.5 mm pitch)
 - 224-pin BGA (13 mm × 13 mm, 0.8 mm pitch)

1. Overview

The MCU integrates multiple series of software-compatible Arm[®]-based 32-bit cores that share a common set of Renesas peripherals to facilitate design scalability and efficient platform-based product development.

The MCU in this series incorporates a high-performance Arm[®] Cortex[®]-M85 core with Helium[™] running up to 480 MHz with the following features:

- Up to 2 MB code flash memory
- 1 MB SRAM (128 KB of TCM RAM, 896 KB of user SRAM)
- Octal Serial Peripheral Interface (OSPI)
- Ethernet MAC Controller (ETHERC), USBFS, USBHS, SD/MMC Host Interface
- Graphics LCD Controller (GLCDC)
- 2D Drawing Engine (DRW)
- MIPI DSI interface
- Analog peripherals
- Security and safety features

1.1 Function Outline

Table 1.1 Arm core

Feature	Functional description
Arm [®] Cortex [®] -M85 core	<ul style="list-style-type: none"> • Maximum operating frequency: up to 480 MHz • Arm[®] Cortex[®]-M85 core <ul style="list-style-type: none"> – Revision: (r0p2-00rel0) – ARMv8.1-M architecture profile – Armv8-M Security Extension – Floating Point Unit (FPU) compliant with the ANSI/IEEE Std 754-2008 Scalar half, single, and double-precision floating-point operation – M-profile Vector Extension (MVE) Integer, half-precision, and single-precision floating-point MVE (MVE-F) – Helium[™] technology is M-profile Vector Extension (MVE) • Arm[®] Memory Protection Unit (Arm MPU) <ul style="list-style-type: none"> – Protected Memory System Architecture (PMSAv8) – Secure MPU (MPU_S): 8 regions – Non-secure MPU (MPU_NS): 8 regions • SysTick timer <ul style="list-style-type: none"> – Embeds two SysTick timers: Secure instance (SysTick_S) and Non-secure instance (SysTick_NS) – Driven by CPUCLK or MOCO divided by 8 • CoreSight[™] ETM-M85

Table 1.2 Memory

Feature	Functional description
Code flash memory	Maximum 2 MB of code flash memory.
Data flash memory	12 KB of data flash memory.
Option-setting memory	The option-setting memory determines the state of the MCU after a reset.
SRAM	On-chip high-speed SRAM with either parity bit or Error Correction Code (ECC). SRAM0 is ECC. SRAM1 is Parity check.
Standby SRAM	On-chip SRAM that can retain data in Deep Software Standby mode 1.
ROM	On-chip immutable ROM contains First Stage Bootloader (FSBL)

Table 1.3 System

Feature	Functional description
Operating modes	Three operating modes: <ul style="list-style-type: none"> • Single-chip mode • JTAG boot mode • SCI/USB boot mode
Resets	This MCU provides 13 types of reset.
Programmable Voltage Detection (PVD)	The Programmable Voltage Detection (PVD) module monitors the voltage level input to the VCC pin. The detection level can be selected by register settings. The PVD module consists of three separate voltage level detectors (PVD0, PVD1, PVD2). PVD0, PVD1, and PVD2 measure the voltage level input to the VCC pin. PVD registers allow your application to configure detection of VCC changes at various voltage thresholds.
Clocks	<ul style="list-style-type: none"> • Main clock oscillator (MOSC) • Sub-clock oscillator (SOSC) • High-speed on-chip oscillator (HOCO) • Middle-speed on-chip oscillator (MOCO) • Low-speed on-chip oscillator (LOCO) • PLL1/PLL2 • Clock out support
Clock Frequency Accuracy Measurement Circuit (CAC)	The Clock Frequency Accuracy Measurement Circuit (CAC) counts pulses of the clock to be measured (measurement target clock) within the time generated by the clock selected as the measurement reference (measurement reference clock), and determines the accuracy depending on whether the number of pulses is within the allowable range. When measurement is complete or the number of pulses within the time generated by the measurement reference clock is not within the allowable range, an interrupt request is generated.
Interrupt Controller Unit (ICU)	The Interrupt Controller Unit (ICU) controls which event signals are linked to the Nested Vector Interrupt Controller (NVIC), the DMA Controller (DMAC), and the Data Transfer Controller (DTC) modules. The ICU also controls non-maskable interrupts.
Low power modes	Power consumption can be reduced in multiple ways, including setting clock dividers, controlling EBCLK output, controlling SDCLK output, stopping modules, power gating control, selecting operating power control modes in normal operation, and transitioning to low power modes and processor low power modes.
Battery backup function	A battery backup function is provided for partial powering by a battery. The battery-powered area includes the RTC, SOSC, backup register, tamper detection and VBATT_R voltage drop detection and switch between VCC and VBATT.
Register write protection	The register write protection function protects important registers from being overwritten due to software errors. The registers to be protected are set with the Protect Register (PRCR_S and PRCR_NS).
Memory Protection Unit (MPU)	All bus masters have Memory Protection Units (MPUs).

Table 1.4 Event link

Feature	Functional description
Event Link Controller (ELC)	The Event Link Controller (ELC) uses the event requests generated by various peripheral modules as source signals to connect them to different modules, allowing direct link between the modules without CPU intervention.

Table 1.5 Direct memory access

Feature	Functional description
Data Transfer Controller (DTC)	A Data Transfer Controller (DTC) module is provided for transferring data when activated by an interrupt request.
DMA Controller (DMAC)	The 8-channel direct memory access controller (DMAC) that can transfer data without intervention from the CPU. When a DMA transfer request is generated, the DMAC transfers data stored at the transfer source address to the transfer destination address.

Table 1.6 External bus interface

Feature	Functional description
External buses	<ul style="list-style-type: none"> CS area (ECBI): Connected to the external devices (external memory interface) SDRAM area (ECBI): Connected to the SDRAM (external memory interface) OSPI area (EOBI): Connected to the OSPI (external device interface)

Table 1.7 Timers

Feature	Functional description
General PWM Timer (GPT)	The General PWM Timer (GPT) is a 32-bit timer with GPT32 × 8 channels and a 16-bit timer with GPT16 × 6 channels. PWM waveforms can be generated by controlling the up-counter, down-counter, or the up- and down-counter. In addition, PWM waveforms can be generated for controlling brushless DC motors. The GPT can also be used as a general-purpose timer.
Port Output Enable for GPT (POEG)	The Port Output Enable (POEG) function can place the General PWM Timer (GPT) output pins in the output disable state
Low Power Asynchronous General Purpose Timer (AGT)	The Low Power Asynchronous General Purpose Timer (AGT) is a 16-bit timer that can be used for pulse output, external pulse width or period measurement, and counting external events. This timer consists of a reload register and a down counter. The reload register and the down counter are allocated to the same address, and can be accessed with the AGT register.
Ultra-Low-Power Timer (ULPT)	The Ultra-Low-Power Timer (ULPT) is a 32-bit timer which can be used for outputting pulses or counting external events. This 32-bit timer consists of reload registers and a down-counter. The reload registers and the down-counter are allocated to the same address and can be accessed through the ULPTCNT register.
Realtime Clock (RTC)	The realtime clock (RTC) has two counting modes, calendar count mode and binary count mode, that are used by switching register settings. For calendar count mode, the RTC has a 100-year calendar from 2000 to 2099 and automatically adjusts dates for leap years. For binary count mode, the RTC counts seconds and retains the information as a serial value. Binary count mode can be used for calendars other than the Gregorian (Western) calendar.
Watchdog Timer (WDT)	The Watchdog Timer (WDT) is a 14-bit down counter that can be used to reset the MCU when the counter underflows because the system has run out of control and is unable to refresh the WDT. In addition, the WDT can be used to generate a non-maskable interrupt or an underflow interrupt.
Independent Watchdog Timer (IWDT)	The Independent Watchdog Timer (IWDT) has a 14-bit down-counter, which resets the MCU by a reset output when the down-counter underflows. Alternatively, generation of an interrupt request when the counter underflows can be selected. This enables detection of a program runaway taking the refresh interval into account. The IWDT has two start modes: auto start mode, in which counting automatically starts after release from the reset state, and register start mode, in which counting is started by refreshing (writing to a specific register).

Table 1.8 Communication interfaces (1 of 2)

Feature	Functional description
Serial Communications Interface (SCI)	<p>The Serial Communications Interface (SCI) × 6 channels have asynchronous and synchronous serial interfaces:</p> <ul style="list-style-type: none"> Asynchronous interfaces (UART and Asynchronous Communications Interface Adapter (ACIA)) 8-bit clock synchronous interface Simple IIC (master-only) Simple SPI Smart card interface Manchester interface Simple LIN interface <p>The smart card interface complies with the ISO/IEC 7816-3 standard for electronic signals and transmission protocol. All channels have FIFO buffers to enable continuous and full-duplex communication, and the data transfer speed can be configured independently using an on-chip baud rate generator.</p> <p>The maximum rate supported on this MCU. Refer to the electrical characteristics for the actual rate.</p>
I ² C Bus interface (IIC)	The I ² C Bus interface (IIC) has 2 channels. The IIC module conforms with and provides a subset of the NXP I ² C (Inter-Integrated Circuit) bus interface functions.
I ³ C Bus Interface (I3C)	The I3C Bus Interface (I3C) has 1 channel. The I3C module conform with and provide a subset of the NXP I ² C (Inter-Integrated Circuit) bus interface functions and a subset of the MIPI I3C.

Table 1.8 Communication interfaces (2 of 2)

Feature	Functional description
Serial Peripheral Interface (SPI)	The Serial Peripheral Interface (SPI) provides high-speed full-duplex synchronous serial communications with multiple processors and peripheral devices. The maximum rate supported on this MCU. Refer to the electrical characteristics for the actual rate.
Control Area Network with Flexible Data-Rate Module (CANFD)	The CAN with Flexible Data-Rate (CANFD) module can handle classical CAN frames and CANFD frames complied with ISO 11898-1 standard. The module supports 4 transmit buffers per channel and 16 receive buffers per channel.
USB 2.0 Full-Speed module (USBFS)	The USB 2.0 Full-Speed module (USBFS) can operate as a host controller or device controller. The module supports full-speed and low-speed (host controller only) transfer as defined in Universal Serial Bus Specification 2.0. The module has an internal USB transceiver and supports all of the transfer types defined in Universal Serial Bus Specification 2.0. The USB has buffer memory for data transfer, providing a maximum of 10 pipes. Pipes 1 to 9 can be assigned any endpoint number based on the peripheral devices used for communication or based on your system.
USB 2.0 High-speed Module (USBHS)	The USB 2.0 High-Speed Module (USBHS) that operates as a host or a device controller compliant with the Universal Serial Bus (USB) Specification revision 2.0. The host controller supports USB 2.0 high-speed, full speed, and low-speed transfers, and the device controller supports USB 2.0 high-speed and full-speed transfers. The USBHS has an internal USB transceiver and supports all of the transfer types defined in the USB 2.0 specification. The USBHS has FIFO buffer for data transfers, providing a maximum of 10 pipes.
Octal Serial Peripheral Interface (OSPI)	The Octal Serial Peripheral Interface (OSPI) is a memory controller that supports EXpanded Serial Peripheral Interface (xSPI) (JEDEC Standard JESD251, JESD251-1 and JESD252) . The OSPI supports 1-bit, 2-bit, 4-bit and 8-bit protocols. JESD251 specifies two interface profiles where profile 1.0 is Octal SPI and profile 2.0 is HyperBus™.
Serial Sound Interface Enhanced (SSIE)	The Serial Sound Interface Enhanced (SSIE) peripheral provides functionality to interface with digital audio devices for transmitting I ² S/Monaural/TDM audio data over a serial bus. The SSIE supports an audio clock frequency of up to 50 MHz, and can be operated as a slave or master receiver, transmitter, or transceiver to suit various applications. The SSIE includes 32-stage FIFO buffers in the receiver and transmitter, and supports interrupts and DMA-driven data reception and transmission.
SD/MMC Host Interface (SDHI)	The Secure Digital (SD) Card and Multi Media Card (MMC) Host Interface provides the functionality required to connect a variety of external memory cards to the MCU. The SDHI supports both 1- and 4-bit buses for connecting memory cards that support SD, SDHC, and SDXC formats. When developing host devices that are compliant with the SD Specifications, you must comply with the SD Host/Ancillary Product License Agreement (SD HALA). The MMC interface supports 1-bit, 4-bit, and 8-bit MMC buses that provide eMMC 4.51 (JEDEC Standard JESD 84-B451) device access. This interface also provides backward compatibility and supports high-speed SDR transfer modes.
Ethernet Controller (ETHERC)	One-channel Ethernet Controller (ETHERC) compliant with the Ethernet/IEEE802.3 Media Access Control (MAC) layer protocol. An ETHERC channel provides one channel of the MAC layer interface, connecting the MCU to the physical layer LSI (PHY-LSI) that allows transmission and reception of frames compliant with the Ethernet and IEEE802.3 standards. The ETHERC is connected to the Ethernet DMA Controller (EDMAC) so data can be transferred without using the CPU.

Table 1.9 Analog (1 of 2)

Feature	Functional description
12-bit A/D Converter (ADC12)	A 12-bit successive approximation A/D Converter is provided. Up to 25 analog input channels are selectable. Temperature sensor output, and internal reference voltage and VBATT 1/3 voltage monitor are selectable for conversion.
12-bit D/A Converter (DAC12)	A 12-bit D/A Converter (DAC12) is provided.
Temperature Sensor (TSN)	The on-chip Temperature Sensor (TSN) determines and monitors the die temperature for reliable operation of the device. The sensor outputs a voltage directly proportional to the die temperature, and the relationship between the die temperature and the output voltage is fairly linear. The output voltage is provided to the ADC12 for conversion and can be further used by the end application.

Table 1.9 Analog (2 of 2)

Feature	Functional description
High-Speed Analog Comparator (ACMPHS)	The High-Speed Analog Comparator (ACMPHS) can be used to compare an analog input voltage with a reference voltage and to provide a digital output based on the result of conversion. Both the analog input voltage and the reference voltage can be provided to the ACMPHS from internal sources (D/A converter output or internal reference voltage) and an external source. Such flexibility is useful in applications that require go/no-go comparisons to be performed between analog signals without necessarily requiring A/D conversion.

Table 1.10 Human machine interfaces

Feature	Functional description
Graphics LCD Controller (GLCDC)	The Graphics LCD Controller (GLCDC) provides multiple functions and supports various data formats and panels. Key GLCDC features include: <ul style="list-style-type: none"> GLCDC0BI/GLCDC1BI master function for accessing graphics data Superimposition of three planes (single-color background plane, graphic 1-plane, and graphic 2-plane) Support for many types of 32-bit or 16-bit per pixel graphics data and 8-bit, 4-bit, or 1-bit LUT data format Digital interface signal output supporting a video image size of WXGA.
2D Drawing Engine (DRW)	The 2D Drawing Engine (DRW) provides flexible functions that can support almost any object geometry rather than being bound to only a few specific geometries such as lines, triangles, or circles. The edges of every object can be independently blurred or antialiased. Rasterization is executed at one pixel per clock on the bounding box of the object from left to right and top to bottom. The DRW can also raster from bottom to top to optimize the performance in certain cases. In addition, optimization methods are available to avoid rasterization of many empty pixels of the bounding box. The distances to the edges of the object are calculated by a set of edge equations for every pixel of the bounding box. These edge equations can be combined to describe the entire object. If a pixel is inside the object, it is selected for rendering. If it is outside, it is discarded. If it is on the edge, an alpha value can be chosen proportional to the distance of the pixel to the nearest edge for antialiasing. Every pixel that is selected for rendering can be textured. The resulting ARGB quadruple can be modified by a general raster operation approach independently for each of the four channels. The ARGB quadruples can then be blended with one of the multiple blend modes of the DRW. The DRW provides two inputs (texture read and framebuffer read), and one output (framebuffer write). The internal color format is always ARGB (8888). The color formats from the inputs are converted to the internal format on read and a conversion back is made on write.
Capture Engine Unit (CEU)	The Capture Engine Unit (CEU) is a capture module that fetches image data externally input and transfers it to the memory.
MIPI DSI interface	The MIPI DSI interface module has a Transmitter function for MIPI Alliance Specification for Display Serial Interface 2 (DSI-2). This module supports MIPI Alliance Specification for Display Serial Interface 2 (DSI-2) Specification. And it works with MIPI Alliance Specification for D-PHY Specification. This module provides a solution for transmitting MIPI DSI-2 compliant digital video and packets.

Table 1.11 Data processing

Feature	Functional description
Cyclic Redundancy Check (CRC) calculator	The Cyclic Redundancy Check (CRC) calculator generates CRC codes to detect errors in the data. The bit order of CRC calculation results can be switched for LSB-first or MSB-first communication. Additionally, various CRC-generation polynomials are available. The snoop function allows monitoring reads from and writes to specific addresses. This function is useful in applications that require CRC code to be generated automatically in certain events, such as monitoring writes to the serial transmit buffer and reads from the serial receive buffer.
Data Operation Circuit (DOC)	The Data Operation Circuit (DOC) compares, adds, and subtracts 32-bits data. When a selected condition applies, 32-bit data is compared and an interrupt can be generated.

1.2 Block Diagram

Figure 1.1 shows a block diagram of the MCU superset. Some individual devices within the group have a subset of the features.

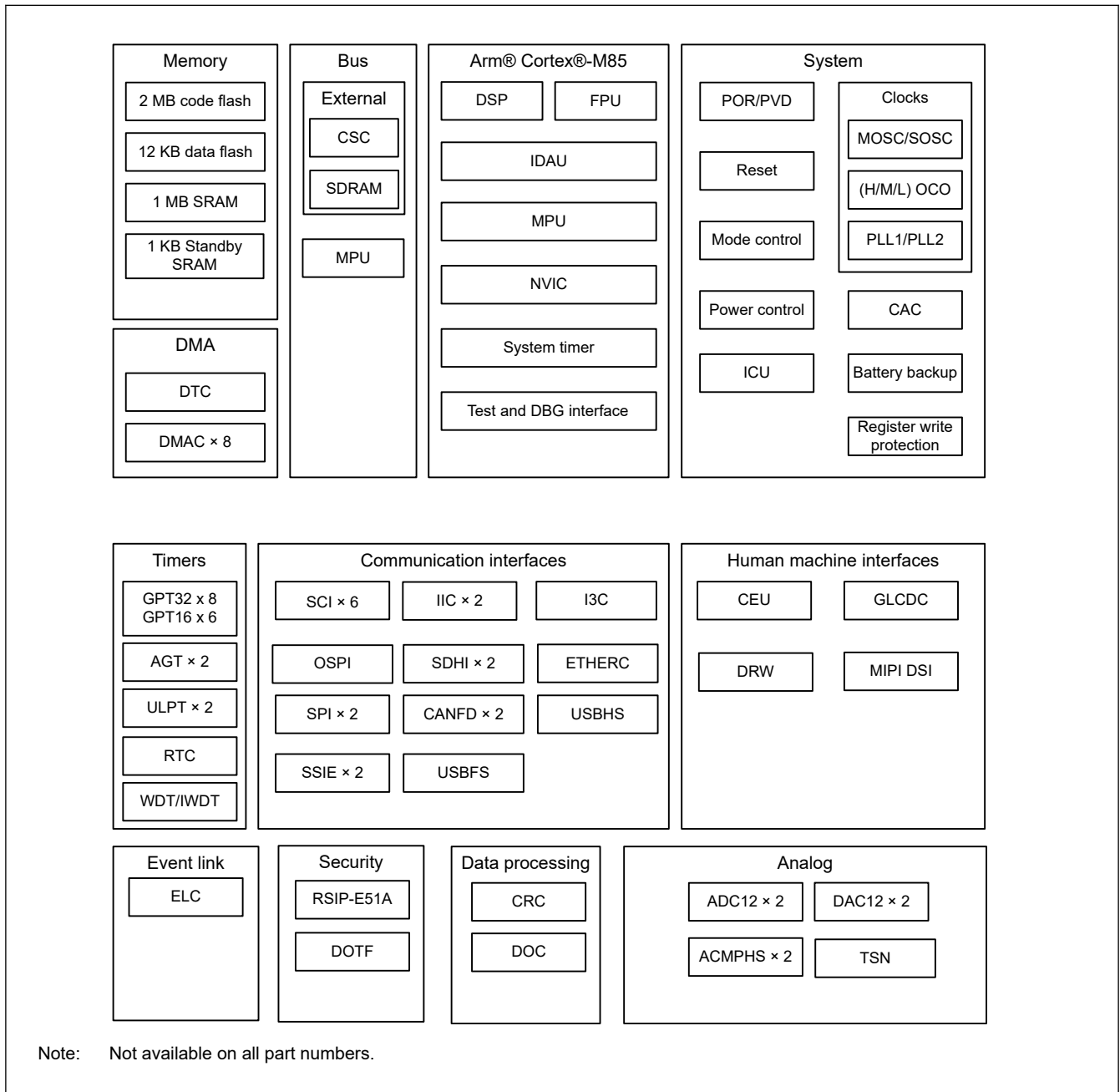

Figure 1.1 Block diagram

1.3 Part Numbering

Figure 1.2 shows the product part number information, including memory capacity and package type. Table 1.12 shows a list of products.

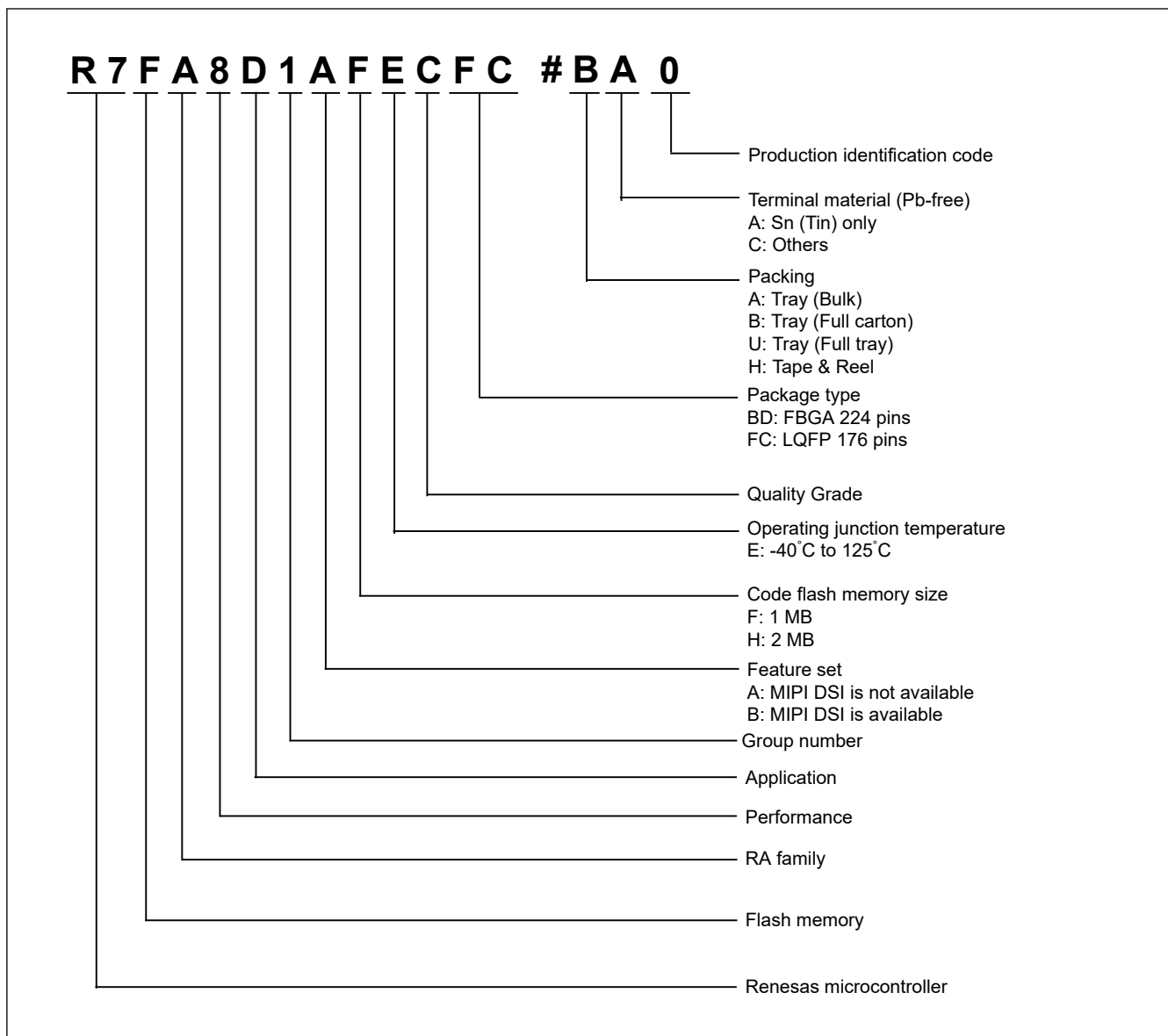

Figure 1.2 Part numbering scheme

Table 1.12 Product list

Product part number	MIPI	Package code	Code flash	Data flash	SRAM	Operating junction temperature
R7FA8D1AHECBD	—	PLBG0224GD-A	2 MB	12 KB	1 MB	-40 to +125°C
R7FA8D1BHECBD	✓					
R7FA8D1AHECFC	—	PLQP0176KJ-A				
R7FA8D1BHECFC	✓					
R7FA8D1AFECBD	—	PLBG0224GD-A	1 MB			
R7FA8D1BFECBD	✓					
R7FA8D1AFECFC	—	PLQP0176KJ-A				
R7FA8D1BFECFC	✓					

1.4 Function Comparison

Table 1.13 Function Comparison (1 of 2)

Parts number		R7FA8D1AxECBD	R7FA8D1BxECBD	R7FA8D1AxECFC	R7FA8D1BxECFC
Pin count		224		176	
Package		BGA		LQFP	
I/O Port		174	165	128	119
Code flash memory		2 MB, 1 MB			
Data flash memory		12 KB			
TCM		128 KB			
I/D Caches		32 KB			
SRAM		896 KB			
		Parity		512 KB	
		ECC		384 KB	
Standby SRAM		1 KB			
DMA		DTC		Yes	
		DMAC		8	
BUS		External bus		32-bit bus	
		SDRAM		16-bit bus	
System		CPU clock		32-bit bus	
		CPU clock sources		480 MHz (max.)	
		CAC		MOSC, SOSC, HOCO, MOCO, PLL1P	
		WDT/IWDT		Yes	
		Backup register		Yes	
Communication		SCI		128 B	
		IIC		6	
		I3C		2	
		SPI		Yes	
		CANFD		2	
		USBFS		2	
		USBHS		Yes	
		OSPI		Yes	
		SSIE		2	
		SDHI/MMC		2	
		ETHERC		Yes	
Timers		GPT32*1		8	
		GPT16*1		6	
		AGT*1		2	
		ULPT*1		2	
		RTC		Yes	
Analog		ADC12		Unit 0: 12, Unit 1: 13	
		DAC12		Unit 0: 12, Unit 1: 12	
		ACMPHS		2	
		TSN		2	
				Yes	

Table 1.13 Function Comparison (2 of 2)

Parts number		R7FA8D1AxECBD	R7FA8D1BxECBD	R7FA8D1AxECFC	R7FA8D1BxECFC
HMI	GLCDC	RGB888			
	DRW	Yes			
	MIPI DSI	No	Yes	No	Yes
	CEU	Yes			
Data processing	CRC	Yes			
	DOC	Yes			
Event control	ELC	Yes			
Security		RSIP-E51A, Secure Debug, Immutable Storage, TrustZone, and Lifecycle management			

Note: The product name differs depend on the memory size and MIPI DSI is supported. see [section 1.3. Part Numbering](#).

Note 1. Available pins depend on the Pin count, about details see [section 1.7. Pin Lists](#).

1.5 Pin Functions

Table 1.14 Pin functions (1 of 7)

Function	Signal	I/O	Description
Power supply	VCC, VCC2	Input	Power supply pin. Connect it to the system power supply. Connect this pin to VSS by a 0.1- μ F capacitor. The capacitor should be placed close to the pin.
	VCC_DCDC	Input	Switching regulator power supply pin.
	VLO	I/O	Switching regulator pin.
	VCL	Input	Connect this pin to the VSS pin by the smoothing capacitor used to stabilize the internal power supply. Place the capacitor close to the pin.
	VBATT	Input	Battery Backup power pin
	VSS, VSS_DCDC	Input	Ground pin. Connect it to the system power supply (0 V).
Clock	XTAL	Output	Pins for a crystal resonator. An external clock signal can be input through the EXTAL pin.
	EXTAL	Input	
	XCIN	Input	Input/output pins for the sub-clock oscillator. Connect a crystal resonator between XCOOUT and XCIN.
	XCOOUT	Output	
	EXCIN	Input	External sub-clock input
	CLKOUT	Output	Clock output pin
Operating mode control	MD	Input	Pin for setting the operating mode. The signal level on this pin must not be changed during operation mode transition on release from the reset state.
System control	RES	Input	Reset signal input pin. The MCU enters the reset state when this signal goes low.
CAC	CACREF	Input	Measurement reference clock input pin
On-chip emulator	TMS	Input	On-chip emulator or boundary scan pins
	TDI	Input	
	TCK	Input	
	TDO	Output	
	TCLK	Output	Output clock for synchronization with the trace data
	TDATA0 to TDATA3	Output	Trace data output
	SWO	Output	Serial wire trace output pin
	SWDIO	I/O	Serial wire debug data input/output pin
	SWCLK	Input	Serial wire clock pin
Interrupt	NMI	Input	Non-maskable interrupt request pin
	IRQn	Input	Maskable interrupt request pins
	IRQn-DS	Input	Maskable interrupt request pins that can also be used in Deep Software Standby mode

Table 1.14 Pin functions (2 of 7)

Function	Signal	I/O	Description
External bus interface	EBCLK	Output	Outputs the external bus clock for external devices
	RD	Output	Strobe signal indicating that reading from the external bus interface space is in progress, active-low.
	WR	Output	Strobe signal indicating that writing to the external bus interface space is in progress, in 1-write strobe mode, active-low.
	WRn	Output	Strobe signals indicating that either group of data bus pins (D07 to D00, D15 to D08, D23 to D16 or D31 to D24) is valid in writing to the external bus interface space, in byte strobe mode, active-low.
	BCn	Output	Strobe signals indicating that either group of data bus pins (D07 to D00, D15 to D08, D23 to D16 or D31 to D24) is valid in access to the external bus interface space, in 1-write strobe mode, active-low.
	ALE	Output	Address latch signal when address/data multiplexed bus is selected.
	WAIT	Input	Input pin for wait request signals in access to the external space, active-low.
	CSn	Output	Select signals for CS areas, active-low
	A00 to A23	Output	Address bus
	D00 to D31	I/O	Data bus
	A00/D00 to A15/D15	I/O	Address/data multiplexed bus
SDRAM interface	SDCLK	Output	Outputs the SDRAM-dedicated clock
	CKE	Output	SDRAM clock enable signal
	SDCS	Output	SDRAM chip select signal, active low
	RAS	Output	SDRAM low address strobe signal, active low
	CAS	Output	SDRAM column address strobe signal, active low
	WE	Output	SDRAM write enable signal, active low
	DQMn	Output	SDRAM I/O data mask enable signal for DQ07 to DQ00, DQ15 to DQ08, DQ23 to DQ16 or DQ31 to DQ24.
	A00 to A16	Output	Address bus
	DQ00 to DQ31	I/O	Data bus
GPT	GTETRGA, GTETRGB, GTETRGC, GTETRGD	Input	External trigger input pins
	GTIOCnA, GTIOCnB	I/O	Input capture, output compare, or PWM output pins
	GTADSM0, GTADSM1	Output	A/D conversion start request monitoring output pins
	GTIU	Input	Hall sensor input pin U
	GTIV	Input	Hall sensor input pin V
	GTIW	Input	Hall sensor input pin W
	GTOUUP	Output	3-phase PWM output for BLDC motor control (positive U phase)
	GTOULO	Output	3-phase PWM output for BLDC motor control (negative U phase)
	GTOVUP	Output	3-phase PWM output for BLDC motor control (positive V phase)
	GTOVLO	Output	3-phase PWM output for BLDC motor control (negative V phase)
	GTOWUP	Output	3-phase PWM output for BLDC motor control (positive W phase)
	GTOWLO	Output	3-phase PWM output for BLDC motor control (negative W phase)

Table 1.14 Pin functions (3 of 7)

Function	Signal	I/O	Description
AGT	AGTEEn	Input	External event input enable signals
	AGTIO _n	I/O	External event input and pulse output pins
	AGTO _n	Output	Pulse output pins
	AGTOA _n	Output	Output compare match A output pins
	AGTOB _n	Output	Output compare match B output pins
ULPT	ULPTEEn	Input	External count control input
	ULPTEVIn	Input	External event input
	ULPTO _n	Output	Pulse output
	ULPTOA _n	Output	Output compare match A output
	ULPTOB _n	Output	Output compare match B output
	ULPTEEn-DS	Input	External count control input that can also be used in Deep Software Standby mode1
	ULPTEVIn-DS	Input	External event input that can also be used in Deep Software Standby mode1
	ULPTO _n -DS	Output	Pulse output that can also be used in Deep Software Standby mode1
	ULPTOA _n -DS	Output	Output compare match A output that can also be used in Deep Software Standby mode1
	ULPTOB _n -DS	Output	Output compare match B output that can also be used in Deep Software Standby mode1
RTC	RTCCOUT	Output	Output pin for 1-Hz or 64-Hz clock
	RTCCIC _n	Input	Time capture event input pins
SCI	SCK _n	I/O	Input/output pins for the clock (clock synchronous mode)
	RXD _n	Input	Input pins for received data (asynchronous mode/clock synchronous mode)
	TXD _n	Output	Output pins for transmitted data (asynchronous mode/clock synchronous mode)
	CTS _n _RTS _n	I/O	Input/output pins for controlling the start of transmission and reception (asynchronous mode/clock synchronous mode), active-low.
	CTS _n	Input	Input for the start of transmission.
	DE _n	Output	Driver enable signal for RS-485
	SCL _n	I/O	Input/output pins for the IIC clock (simple IIC mode)
	SDA _n	I/O	Input/output pins for the IIC data (simple IIC mode)
	SCK _n	I/O	Input/output pins for the clock (simple SPI mode)
	MISO _n	I/O	Input/output pins for slave transmission of data (simple SPI mode)
	MOSI _n	I/O	Input/output pins for master transmission of data (simple SPI mode)
	SS _n	Input	Chip-select input pins (simple SPI mode), active-low
IIC	SCL _n	I/O	Input/output pins for the clock
	SDA _n	I/O	Input/output pins for data
I3C	I3C_SCL0	I/O	Input/output pins for the clock
	I3C_SDA0	I/O	Input/output pins for data

Table 1.14 Pin functions (4 of 7)

Function	Signal	I/O	Description
SPI	RSPCKA, RSPCKB	I/O	Clock input/output pin
	MOSIA, MOSIB	I/O	Input or output pins for data output from the master
	MISOA, MISOB	I/O	Input or output pins for data output from the slave
	SSLA0, SSLB0	I/O	Input or output pin for slave selection
	SSLA1 to SSLA3, SSLB1 to SSLB3	Output	Output pins for slave selection
CANFD	CRXn	Input	Receive data
	CTXn	Output	Transmit data
USBFS	VCC_USB	Input	Power supply pin
	VSS_USB	Input	Ground pin
	USB_DP	I/O	D+ pin of the USB on-chip transceiver. Connect this pin to the D+ pin of the USB bus.
	USB_DM	I/O	D- pin of the USB on-chip transceiver. Connect this pin to the D- pin of the USB bus.
	USB_VBUS	Input	USB cable connection monitor pin. Connect this pin to VBUS of the USB bus. The VBUS pin status (connected or disconnected) can be detected when the USB module is operating as a function controller.
	USB_EXICEN	Output	Low-power control signal for external power supply (OTG) chip
	USB_VBUSEN	Output	VBUS (5 V) supply enable signal for external power supply chip
	USB_OVRCURA, USB_OVRCURB	Input	Connect the external overcurrent detection signals to these pins. Connect the VBUS comparator signals to these pins when the OTG power supply chip is connected.
	USB_OVRCURA-DS, USB_OVRCURB-DS	Input	Overcurrent pins for USBFS that can also be used in Deep Software Standby mode ¹ . Connect the external overcurrent detection signals to these pins. Connect the VBUS comparator signals to these pins when the OTG power supply chip is connected.
	USB_ID	Input	Connect the MicroAB connector ID input signal to this pin during operation in OTG mode
USBHS	VCC_USBHS	Input	Power supply pin
	VSS1_USBHS, VSS2_USBHS	Input	Ground pin
	AVCC_USBHS	Input	Analog power supply
	USBHS_RREF	I/O	Reference current source pin for the USBHS Must be connected to the VSS2_USBHS pin through a 2.2-kΩ (±1%) resistor.
	USBHS_DP	I/O	Input/output pin for the D+ data line of the USB bus
	USBHS_DM	I/O	Input/output pin for the D- data line of the USB bus
	USBHS_EXICEN	Output	Must be connected to the OTG power supply IC
	USBHS_ID	input	Must be connected to the OTG power supply IC
	USBHS_VBUSEN	Output	VBUS power supply enable pin for the USBHS
	USBHS_OVRCURA, USBHS_OVRCURB	Input	Overcurrent pin for the USBHS
	USBHS_OVRCURA-DS, USBHS_OVRCURB-DS	Input	Overcurrent pin for the USBHS that can also be used in Deep Software Standby mode ¹ .
	USBHS_VBUS	Input	USB cable connection monitor input pin

Table 1.14 Pin functions (5 of 7)

Function	Signal	I/O	Description
OSPI	OM_SCLK	Output	Clock output (OCTACLK divided by 2)
	OM_SCLKN	Output	Inverted clock output (OCTACLK divided by 2)
	OM_CS _n	Output	Chip select signal for an OctaFlash device, active-low
	OM_DQS	I/O	Read data strobe/write data mask signal
	OM_SIO _n	I/O	Data input/output
	OM_RESET	Output	Reset signal for both slave devices, active-low
	OM_ECSINT1	Input	Error Correction Status and Interrupt for slave1
	OM_RSTO1	Input	Slave reset status for slave1
	OM_WP1	Output	Write Protect for slave1, active-low
SSIE	SSIBCK0, SSIBCK1	I/O	SSIE serial bit clock pins
	SSILRCK0/SSIFS0, SSILRCK1/SSIFS1	I/O	LR clock/frame synchronization pins
	SSITXD0	Output	Serial data output pin
	SSIRXD0	Input	Serial data input pin
	SSIDATA1	I/O	Serial data input/output pins
	AUDIO_CLK	Input	External clock pin for audio (input oversampling clock)
	SDHI/MMC	SDnCLK	Output
SDnCMD		I/O	Command output pin and response input signal pins
SDnDATA0 to SDnDATA7		I/O	SD and MMC data bus pins
SDnCD		Input	SD card detection pins
SDnWP		Input	SD write-protect signals

Table 1.14 Pin functions (6 of 7)

Function	Signal	I/O	Description
ETHERC	REF50CK0	Input	50-MHz reference clock. This pin inputs reference signal for transmission/reception timing in RMII mode.
	RMII0_CRS_DV	Input	Indicates carrier detection signals and valid receive data on RMII0_RXD1 and RMII0_RXD0 in RMII mode
	RMII0_TXDn	Output	2-bit transmit data in RMII mode
	RMII0_RXDn	Input	2-bit receive data in RMII mode
	RMII0_TXD_EN	Output	Output pin for data transmit enable signal in RMII mode
	RMII0_RX_ER	Input	Indicates an error occurred during reception of data in RMII mode
	ET0_CRS	Input	Carrier detection/data reception enable signal
	ET0_RX_DV	Input	Indicates valid receive data on ET0_ERXD3 to ET0_ERXD0
	ET0_EXOUT	Output	General-purpose external output pin
	ET0_LINKSTA	Input	Input link status from the PHY-LSI
	ET0_ETXDn	Output	4 bits of MII transmit data
	ET0_ERXDn	Input	4 bits of MII receive data
	ET0_TX_EN	Output	Transmit enable signal. Functions as signal indicating that transmit data is ready on ET0_ETXD3 to ET0_ETXD0.
	ET0_TX_ER	Output	Transmit error pin. Functions as signal notifying the PHY_LSI of an error during transmission.
	ET0_RX_ER	Output	Receive error pin. Functions as signal to recognize an error during reception.
	ET0_TX_CLK	Input	Transmit clock pin. This pin inputs reference signal for output timing from ET0_TX_EN, ET0_ETXD3 to ET0_ETXD0, and ET0_TX_ER.
	ET0_RX_CLK	Input	Receive clock pin. This pin inputs reference signal for input timing to ET0_RX_DV, ET0_ERXD3 to ET0_ERXD0, and ET0_RX_ER.
	ET0_COL	Input	Input collision detection signal
	ET0_WOL	Output	Receive Magic packets
	ET0_MDC	Output	Output reference clock signal for information transfer through ET0_MDIO
ET0_MDIO	I/O	Input or output bidirectional signal for exchange of management data with PHY-LSI	
Analog power supply	AVCC0	Input	Analog voltage supply pin. This is used as the analog power supply for the respective modules.
	AVSS0	Input	Analog ground pin. This is used as the analog ground for the respective modules. Supply this pin with the same voltage as the VSS pin.
	VREFH	Input	Analog reference voltage supply pin for the ADC12 (unit 1) and D/A Converter. Connect this pin to AVCC0 when not using the ADC12 (unit 1) and D/A Converter.
	VREFL	Input	Analog reference ground pin for the ADC12 and D/A Converter. Connect this pin to AVSS0 when not using the ADC12 (unit 1) and D/A Converter.
	VREFH0	Input	Analog reference voltage supply pin for the ADC12 (unit 0). Connect this pin to AVCC0 when not using the ADC12 (unit 0).
	VREFL0	Input	Analog reference ground pin for the ADC12. Connect this pin to AVSS0 when not using the ADC12 (unit 0).

Table 1.14 Pin functions (7 of 7)

Function	Signal	I/O	Description
ADC12	ANmn	Input	Input pins for the analog signals to be processed by the A/D converter. (m: ADC unit number, n: pin number)
	ADTRGm	Input	Input pins for the external trigger signals that start the A/D conversion, active-low.
DAC12	DAn	Output	Output pins for the analog signals processed by the D/A converter.
ACMPHS	VCOUT	Output	Comparator output pin
	IVREFn	Input	Reference voltage input pins for comparator
	IVCMPn	Input	Analog voltage input pins for comparator
I/O ports	Pmn	I/O	General-purpose input/output pins (m: port number, n: pin number)
	P200	Input	General-purpose input pin
GLCDC	LCD_DATA23 to LCD_DATA00	Output	Data output pins for panel
	LCD_TCON3 to LCD_TCON0	Output	Output pins for panel timing adjustment
	LCD_CLK	Output	Panel clock output pin
	LCD_EXTCLK	Input	Panel clock source input pin
MIPI	VCC18_MIPI	Input	Power supply pin
	AVCC_MIPI	Input	Analog power supply
	VSS_MIPI	Input	Ground pin
	MIPI_CL_P	Output	DSI Clock Lane positive pin
	MIPI_CL_N	Output	DSI Clock Lane negative pin
	MIPI_DL0_P	I/O	DSI Data Lane 0 positive pin
	MIPI_DL0_N	I/O	DSI Data Lane 0 negative pin
	MIPI_DL1_P	Output	DSI Data Lane 1 positive pin
	MIPI_DL1_N	Output	DSI Data Lane 1 negative pin
DSI_TE	Input	DSI Tearing Effect pin	
CEU	VIO_D15 to VIO_D0	Input	CEU data bus pins
	VIO_CLK	Input	CEU clock pin
	VIO_VD	Input	CEU vertical sync pin
	VIO_HD	Input	CEU horizontal sync pin

1.6 Pin Assignments

The following figures show the pin assignments from the top view.

	1	2	3	4	5	6	7	8	9	10	11	12	13	14	15	
A	NC	P301	P304	P306	P308	P905	P909	VCL	RES	MIPL_DL1_N	MIPL_CL_N	MIPL_DLO_N	VCC_USB	P814/USB_DP	P413	A
B	P609	P112	P302	P305	P307	P311	P907	P200	AVCC_MIPI	MIPL_DL1_P	MIPL_CL_P	MIPL_DLO_P	VSS_USB	P815/USB_DM	P408	B
C	PA14	P114	P113	P303	P915	P309	P906	P908	P903	VSS_MIPI	VCC18_MIPI	VSS	P207	P415	P412	C
D	P611	PA12	P115	PA11	P300	P310	P312	P210/TMS/SWDIO	P904	P902	P206	P407	P411	P410	P414	D
E	PA09	P613	P615	P610	PA13	P911	P910	P913	P201/MD	P211/TCK/SWCLK	P409	P712	P708	P710	P709	E
F	VCL	PA10	P612	P614	PA15	P914	P912	P208/TDI	P209/TDO	P711	P715	VCC	VCC_USBHS	USBHS_DP	USBHS_DM	F
G	VCC_DCDC	VCC_DCDC	PA08	PA03	PA07	VCL	VSS	VSS	VCC	P714	P713	VCC	USBHS_RREF	VSS2_USBHS	VSS1_USBHS	G
H	VLO	VLO	PA01	PA00	PA05	VCL	VSS	VSS	VCC	P804	P805	VSS	AVCC_USBHS	P213/XTAL	P212/EXTAL	H
J	VSS_DCDC	VSS	VCC2	P607	P813	VCC	VSS	VSS	VCC	P802	P806	P807	VSS	XCOUT	XCIN	J
K	P107	P106	P600	P601	P605	PA02	P503	P505	P511	P705	P707	P704	P706	VBATT	VCL	K
L	P104	P103	P105	P602	PA06	PA04	P507	P509	P009	P404	P703	P701	P702	P800	P801	L
M	P102	P101	P800	P603	P606	P811	P508	P010	P011	P007	P805	P402	P406/EXCIN	P700	P803	M
N	P100	P801	P803	P604	P504	P506	P510	AVCC0	AVSS0	P005	P806	P807	P512	P403	P405	N
P	P802	P804	VCC2	P810	P500	P502	P014	VREFL	VREFL0	P004	P003	P001	P513	P514	P401	P
R	P808	P809	VSS	P812	P501	VCL	P015	VREFH	VREFH0	P008	P006	P002	P000	P515	P400	R
	1	2	3	4	5	6	7	8	9	10	11	12	13	14	15	

Figure 1.3 Pin assignment for BGA 224-pin

	1	2	3	4	5	6	7	8	9	10	11	12	13	14	15	
A	NC	P301	P304	P306	P308	P905	P909	VCL	RES	P314	P202	P204	VCC_USB	P814/ USB_DP	P413	A
B	P609	P112	P302	P305	P307	P311	P907	P200	P901	P313	P203	P205	VSS_USB	P815/ USB_DM	P408	B
C	PA14	P114	P113	P303	P915	P309	P906	P908	P903	P900	P315	VSS	P207	P415	P412	C
D	P611	PA12	P115	PA11	P300	P310	P312	P210/ TMS/ SWDIO	P904	P902	P206	P407	P411	P410	P414	D
E	PA09	P613	P615	P610	PA13	P911	P910	P913	P201/MD	P211/TCK/ SWCLK	P409	P712	P708	P710	P709	E
F	VCL	PA10	P612	P614	PA15	P914	P912	P208/TDI	P209/TDO	P711	P715	VCC	VCC_USBHS	USBHS_DP	USBHS_DM	F
G	VCC_DCDC	VCC_DCDC	PA08	PA03	PA07	VCL	VSS	VSS	VCC	P714	P713	VCC	USBHS_RREF	VSS2_USBHS	VSS1_USBHS	G
H	VLO	VLO	PA01	PA00	PA05	VCL	VSS	VSS	VCC	PB04	PB05	VSS	AVCC_USBHS	P213 /XTAL	P212 /EXTAL	H
J	VSS_DCDC	VSS	VCC2	P607	P813	VCC	VSS	VSS	VCC	PB02	PB06	PB07	VSS	XCOUT	XCIN	J
K	P107	P106	P600	P601	P605	PA02	P503	P505	P511	P705	P707	P704	P706	VBATT	VCL	K
L	P104	P103	P105	P602	PA06	PA04	P507	P509	P009	P404	P703	P701	P702	PB00	PB01	L
M	P102	P101	P800	P603	P606	P811	P508	P010	P011	P007	P805	P402	P406 /XCIN	P700	PB03	M
N	P100	P801	P803	P604	P504	P506	P510	AVCC0	AVSS0	P005	P806	P807	P512	P403	P405	N
P	P802	P804	VCC2	P810	P500	P502	P014	VREFL	VREFL0	P004	P003	P001	P513	P514	P401	P
R	P808	P809	VSS	P812	P501	VCL	P015	VREFH	VREFH0	P008	P006	P002	P000	P515	P400	R
	1	2	3	4	5	6	7	8	9	10	11	12	13	14	15	

Figure 1.4 Pin assignment for without_MIPI_BGA 224-pin

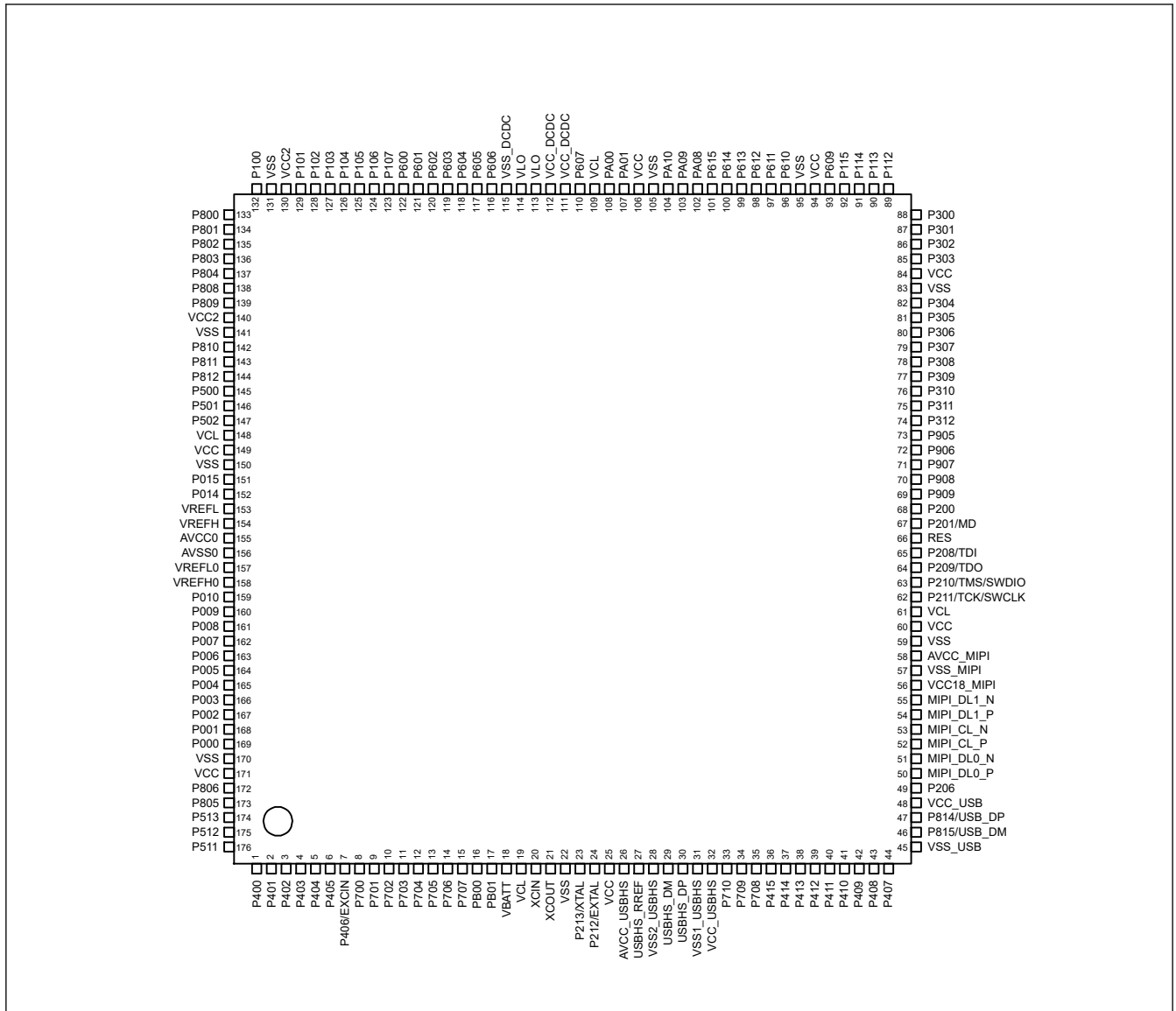

Figure 1.5 Pin assignment for LQFP 176-pin

1.7 Pin Lists

Table 1.15 Pin list (1 of 7)

BCA224	BCA224 without MIP1	LOFP176	LOFP176 without MIP1	Power, System, Clock, Debug, CAC	I/O ports	Ex. Bus, SDRAM	Ex. Interrupt	SCI/IIC/I3C/SPI/CANFD/USBFS/USBHS/OSPI/SSIE/SDHI/MMC/EHTERC(MII, RMII)	GPT/AGT/ULPT/RTC	ADC12/DAC12/ACMPHS	MIPI, GLCDC, CEU
R15	R15	1	1	-	P400	-	IRQ0	TXD1_A/MOSI1_A/SDA1_A/I3C_SCL0/AUDIO_CLK/SD1CLK_B/ET0_WOL/ET0_WOL	GTIOC6A/AGTIO1	ADTRG1	VIO_D0
P15	P15	2	2	-	P401	-	IRQ5-DS	RXD1_A/MISO1_A/SCL1_A/I3C_SDA0/CTX0/SD1CMD_B/ET0_MDC/ET0_MDC	GTETRGA/GTIOC6B	-	VIO_D1
M12	M12	3	3	CACREF	P402	-	IRQ4-DS	SCK1_A/DE1/CRX0/AUDIO_CLK/SD1DAT0_B/ET0_MDIO/ET0_MDIO	RTCIC0	-	-
N14	N14	4	4	-	P403	-	IRQ14-DS	CTS_RTS4_A/SS4_A/DE1/SSIBCK0_A/SD1DAT1_B/ET0_LINKSTA/ET0_LINKSTA	GTIOC3A/RTCIC1	-	-
L10	L10	5	5	-	P404	-	IRQ15-DS	CTS1_A/SSILRCK0/SSIFS0_A/SD1DAT2_B/ET0_EXOUT/ET0_EXOUT	GTIOC3B/RTCIC2	-	VIO_D3
N15	N15	6	6	-	P405	-	-	SCK2_B/DE2/SSITXD0_A/SD1DAT3_B/ET0_TX_EN/RMII0_TXD_EN_B	GTIOC1A/AGTIO1	-	VIO_D2
M13	M13	7	7	EXCIN	P406	-	-	TXD2_B/MOSI2_B/SDA2_B/SSLA3_C/SSIRXD0_A/SD1CD/ET0_RX_ER/RMII0_TXD1_B	GTIOC1B	-	VIO_D3
M14	M14	8	8	-	P700	-	-	RXD2_B/MISO2_B/SCL2_B/MISOA_C/SSIDATA1_B/SD1WP/ET0_ETXD1/RMII0_TXD0_B	GTIOC5A	-	VIO_D4
L12	L12	9	9	-	P701	-	-	CTS_RTS2_B/SS2_B/DE2/MOSIA_C/SSILRCK1/SSIFS1_B/SD1DAT4_B/ET0_ETXD0/REF50CK0_B	GTIOC5B/ULPTO1	-	VIO_D5
L13	L13	10	10	-	P702	-	-	CTS2_B/RSPCKA_C/SSIBCK1_B/SD1DAT5_B/ET0_ERXD1/RMII0_RXD0_B	GTIOC6A/ULPTO0	-	VIO_D6
L11	L11	11	11	-	P703	-	-	SSLA0_C/SD1DAT6_B/ET0_ERXD0/RMII0_RXD1_B	GTIOC6B/AGTO1	VCOUT	VIO_D7
K12	K12	12	12	-	P704	-	-	SSLA1_C/CTX0/SD1DAT7_B/ET0_RX_CLK/RMII0_RX_ER_B	GTADSM0/AGTO0	-	VIO_D8
K10	K10	13	13	-	P705	-	-	CTS1_B/SSLA2_C/CRX0/ET0_CRS/RMII0_CRS_DV_B	GTADSM1/AGTIO0	-	VIO_D9
K13	K13	14	14	-	P706	-	IRQ7	RXD1_B/MISO1_B/SCL1_B/USBHS_OVRCURB-DS	AGTIO0	-	VIO_D10
K11	K11	15	15	-	P707	-	IRQ8	TXD1_B/MOSI1_B/SDA1_B/USBHS_OVRCURA-DS	-	-	LCD_DATA23_B
L14	L14	16	16	-	PB00	-	-	SCK1_B/DE1/USBHS_VBUSEN	-	-	LCD_DATA22_B
J10	J10	-	-	-	PB02	-	-	-	-	-	LCD_DATA21_B
M15	M15	-	-	-	PB03	-	-	-	-	-	LCD_DATA20_B
H10	H10	-	-	-	PB04	-	-	-	-	-	LCD_DATA19_B
L15	L15	17	17	-	PB01	ALE	-	CTS_RTS1_B/SS1_B/DE1/USBHS_VBUS	-	-	LCD_DATA18_B/VIO_D11
H11	H11	-	-	-	PB05	-	-	-	-	-	LCD_DATA17_B
J11	J11	-	-	-	PB06	-	-	-	GTIOC9A	-	LCD_DATA16_B
J12	J12	-	-	-	PB07	-	-	-	GTIOC9B	-	LCD_DATA15_B
K14	K14	18	18	VBATT	-	-	-	-	-	-	-
K15	K15	19	19	VCL	-	-	-	-	-	-	-
J15	J15	20	20	XCIN	-	-	-	-	-	-	-
J14	J14	21	21	XCOUT	-	-	-	-	-	-	-
J13	J13	22	22	VSS	-	-	-	-	-	-	-
H14	H14	23	23	XTAL	P213	-	IRQ2	TXD1_C/MOSI1_C/SDA1_C	GTETRGC/GTIOC0A/ULPTEE0	ADTRG1	-
H15	H15	24	24	EXTAL	P212	-	IRQ3	RXD1_C/MISO1_C/SCL1_C	GTETRGD/GTIOC0B/AGTEE1	-	-
G12	G12	25	25	VCC	-	-	-	-	-	-	-
H13	H13	26	26	AVCC_USBHS	-	-	-	-	-	-	-

Table 1.15 Pin list (2 of 7)

BGA224	BGA224 without MIPI	LQFP176	LQFP176 without MIPI	Power, System, Clock, Debug, CAC	I/O ports	Ex. Bus, SDRAM	Ex. Interrupt	SCI/IIC/I3C/SPI/CANFD/USBFS/USBHS/OSPI/SSIE/SDHI/MMC/EHTERC(MII,RMII)	GPT/AGT/ULPT/RTC	ADC12/DAC12/ACMPHS	MIPI, GLCDC, CEU
G13	G13	27	27	USBHS_RREF	-	-	-	-	-	-	-
G14	G14	28	28	VSS2_USBHS	-	-	-	-	-	-	-
F15	F15	29	29	-	-	-	-	USBHS_DM	-	-	-
F14	F14	30	30	-	-	-	-	USBHS_DP	-	-	-
G15	G15	31	31	VSS1_USBHS	-	-	-	-	-	-	-
F13	F13	32	32	VCC_USBHS	-	-	-	-	-	-	-
F11	F11	-	-	-	P715	-	-	RXD4_C/MISO4_C/SCL4_C	-	-	LCD_DATA14_B
G10	G10	-	-	-	P714	-	-	TXD4_C/MOSI4_C/SDA4_C	-	-	LCD_DATA13_B
H12	H12	-	-	VSS	-	-	-	-	-	-	-
G11	G11	-	-	-	P713	-	-	-	GTIOC2A/AGTOA0	-	LCD_DATA12_B
E12	E12	-	-	-	P712	-	-	-	GTIOC2B/AGTOB0	-	LCD_DATA11_B
F10	F10	-	-	-	P711	-	-	-	AGTEE0	-	LCD_DATA10_B
E14	E14	33	33	-	P710	CS5	-	CTS4_B	-	-	VIO_VD
E15	E15	34	34	-	P709	CS4	IRQ10	CTS_RTS4_B/SS4_B/DE4	-	-	VIO_HD
E13	E13	35	35	CACREF	P708	WR1/BC1	IRQ11	SCK4_B/DE4/SSLB3_B/AUDIO_CLK	-	-	VIO_CLK
C14	C14	36	36	-	P415	WAIT	IRQ8	TXD4_B/MOSI4_B/SDA4_B/SSLB2_B/CTX1/SD0CD	GTADSM0/GTIOC0A	-	VIO_D12
D15	D15	37	37	-	P414	A23	IRQ9	RXD4_B/MISO4_B/SCL4_B/SSLB1_B/CRX1/SD0WP	GTADSM1/GTIOC0B	-	VIO_D13
A15	A15	38	38	-	P413	A22	-	SSLB0_B/SD0CLK_A	GTOUUP/ULPTEE1	-	-
C15	C15	39	39	-	P412	A21	-	CTS3_A/RSPCKB_B/USB_EXICEN/USBHS_EXICEN/SD0CMD_A	GTOULO/AGTEE1	-	-
D13	D13	40	40	-	P411	A20	IRQ4	CTS_RTS3_A/SS3_A/DE3/MOSIB_B/USB_ID/USBHS_ID/SD0DAT0_A	GTOVUP/GTIOC9A/AGTOA1	-	-
D14	D14	41	41	-	P410	A19	IRQ5	SCK3_A/DE3/SCL0_A/MISOB_B/USB_OVRCURB-DS/USBHS_OVRCURB/SD0DAT1_A	GTOVLO/GTIOC9B/AGTOB1	-	-
E11	E11	42	42	-	P409	A18	IRQ6	TXD3_A/MOSI3_A/SDA3_A/SDA0_A/USB_OVRCURA-DS/USBHS_OVRCURA	GTOVUP/ULPTOA0	-	-
G6	G6	-	-	VCL	-	-	-	-	-	-	-
B15	B15	43	43	-	P408	A17	IRQ7	CTS4_A/RXD3_A/MISO3_A/SCL3_A/SCL0_B/USB_VBUSEN/USBHS_VBUSEN	GTOVLO/GTIOC10A/ULPTOB0	-	-
D12	D12	44	44	-	P407	CS6	-	CTS_RTS4_A/SS4_A/DE4/SDA0_B/SSLA3_A/USB_VBUS	GTIOC10B/AGTIO0/RTCOUT	ADTRG0	-
B13	B13	45	45	VSS_USB	-	-	-	-	-	-	-
B14	B14	46	46	-	P815	-	-	CTX0/USB_DM	GTIOC8A	-	-
A14	A14	47	47	-	P814	-	-	CRX0/USB_DP	GTIOC8B	-	-
A13	A13	48	48	VCC_USB	-	-	-	-	-	-	-
C13	C13	-	-	-	P207	-	-	-	-	-	LCD_DATA9_B
D11	D11	49	49	-	P206	CS7	IRQ0-DS	RXD4_A/MISO4_A/SCL4_A/SDA1_B/SSLA2_A/USB_VBUSEN/SSIDATA1_A/SD0DAT2_A	GTIU	-	DSI_TE
B12	-	50	-	MIPI_DL0_P	-	-	-	-	-	-	-
A12	-	51	-	MIPI_DL0_N	-	-	-	-	-	-	-
B11	-	52	-	MIPI_CL_P	-	-	-	-	-	-	-
A11	-	53	-	MIPI_CL_N	-	-	-	-	-	-	-
B10	-	54	-	MIPI_DL1_P	-	-	-	-	-	-	-
A10	-	55	-	MIPI_DL1_N	-	-	-	-	-	-	-
C11	-	56	-	VCC18_MIPI	-	-	-	-	-	-	-
C10	-	57	-	VSS_MIPI	-	-	-	-	-	-	-

Table 1.15 Pin list (3 of 7)

BGA224	BGA224 without MIPI	LQFP176	LQFP176 without MIPI	Power, System, Clock, Debug, CAC	I/O ports	Ex. Bus, SDRAM	Ex. Interrupt	SCI/IIC/I3C/SPI/CANFD/USBFS/USBHS/OSPI/SSIE/SDHI/MMC/EHTERC(MII,RMII)	GPT/AGT/ULPT/RTC	ADC12/DAC12/ACMPHS	MIPI, GLCDC, CEU
B9	-	58	-	AVCC_MIPI	-	-	-	-	-	-	-
-	B12	-	50	CLKOUT	P205	-	IRQ1-DS	TXD4_A/MOSI4_A/SDA4_A/SCL1_B/SSLA1_A/USB_OVRCURB/SSILRCK1/SSIFS1_A/SD0DAT3_A	GTIV/GTIOC4A/AGTO1	-	-
-	A12	-	51	CACREF	P204	-	-	SCK4_A/DE4/SSLA0_A/USB_OVRCURB/SSIBCK1_A/SD0DAT4_A	GTIW/GTIOC4B/AGTIO1	-	-
-	B11	-	52	-	P203	-	IRQ2-DS	RSPCKA_A/CTX0/SD0DAT5_A	GTIOC5A/ULPTOA1	-	-
-	A11	-	53	-	P202	-	IRQ3-DS	MOSIA_A/CRX0/SD0DAT6_A	GTIOC5B/ULPTOB1	-	-
-	B10	-	54	-	P313	-	-	CTS3_C/MISOA_A/SD0DAT7_A	-	-	-
-	A10	-	55	-	P314	-	-	CTS_RTS3_C/SS3_C/DE3	-	ADTRG0	-
-	C11	-	56	-	P315	-	-	SCK3_C/DE3	-	-	-
-	C10	-	57	-	P900	-	-	TXD3_C/MOSI3_C/SDA3_C	-	-	-
-	B9	-	58	-	P901	-	-	RXD3_C/MISO3_C/SCL3_C	AGTIO1	-	-
D10	D10	-	-	-	P902	-	-	-	-	-	LCD_DATA8_B
C12	C12	59	59	VSS	-	-	-	-	-	-	-
F12	F12	60	60	VCC	-	-	-	-	-	-	-
C9	C9	-	-	-	P903	-	-	-	GTIOC11A	-	LCD_DATA7_B
D9	D9	-	-	-	P904	-	-	-	GTIOC11B	-	LCD_DATA6_B
A8	A8	61	61	VCL	-	-	-	-	-	-	-
E10	E10	62	62	TCK/SWCLK	P211	-	-	SCK9_B/DE9	GTOUJUP/GTIOC0A	-	-
D8	D8	63	63	TMS/SWDIO	P210	-	-	CTS_RTS9_B/SS9_B/DE9	GTOULO/GTIOC0B	-	-
F9	F9	64	64	TDO/SWO/CLKOUT	P209	-	-	TXD9_B/MOSI9_B/SDA9_B/CTX1	GTOUJUP/GTIOC1A	-	-
F8	F8	65	65	TDI	P208	-	IRQ3	RXD9_B/MISO9_B/SCL9_B/CRX1	GTOVLO/GTIOC1B	VCOUT	-
E8	E8	-	-	CLKOUT	P913	-	-	-	-	-	LCD_DATA5_B
A9	A9	66	66	RES	-	-	-	-	-	-	-
E9	E9	67	67	MD	P201	-	-	-	-	-	-
B8	B8	68	68	-	P200	-	NMI	-	-	-	-
F7	F7	-	-	-	P912	-	-	-	GTIOC3A	-	LCD_DATA4_B
E6	E6	-	-	-	P911	-	-	-	GTIOC3B	-	LCD_DATA3_B
E7	E7	-	-	-	P910	-	-	-	-	-	LCD_DATA2_B
A7	A7	69	69	-	P909	CS3/CAS	-	USBHS_EXICEN	GTIOC12A	-	LCD_DATA23_A
C8	C8	70	70	-	P908	CS2/RAS	IRQ11	USBHS_ID	GTIOC12B	-	LCD_DATA22_A
B7	B7	71	71	-	P907	A16/A16	IRQ10	USB_EXICEN	GTIOC13A	-	LCD_DATA21_A
C7	C7	72	72	-	P906	A15/A15	IRQ9	USB_ID	GTIOC13B	-	LCD_DATA20_A
A6	A6	73	73	-	P905	A14/A14	IRQ8	CTS3_B	-	-	LCD_DATA19_A
D7	D7	74	74	-	P312	A13/A13	-	CTS_RTS3_B/SS3_B/DE3/CTX0/ET0_TX_CLK	GTADSM0/AGTOA1	-	LCD_DATA18_A
B6	B6	75	75	-	P311	A12/A12	-	SCK3_B/DE3/CRX0/ET0_TX_ER	GTADSM1/AGTOB1	-	LCD_DATA17_A
G8	G8	-	-	VSS	-	-	-	-	-	-	-
D6	D6	76	76	-	P310	A11/A11	-	TXD3_B/MOSI3_B/SDA3_B/ET0_ETXD2	AGTEE1	-	LCD_DATA16_A
C6	C6	77	77	-	P309	A10/A10	-	RXD3_B/MISO3_B/SCL3_B/ET0_ETXD3	-	-	LCD_DATA15_A
A5	A5	78	78	TCLK	P308	A9/A9	-	CTS9_B/SD0CLK_B/ET0_MDC/ET0_MDC	GTIU/ULPTOB1	-	-
B5	B5	79	79	TDATA0	P307	A8/A8	-	SD0CMD_B/ET0_MDIO/ET0_MDIO	GTIV/ULPTOA1	-	-
A4	A4	80	80	TDATA1	P306	A7/A7	-	SD0CD/ET0_TX_EN/RMII0_TXD_EN_A	GTIW/ULPTEV1	-	-

Table 1.15 Pin list (4 of 7)

BGA224	BGA224 without MIPI	LQFP176	LQFP176 without MIPI	Power, System, Clock, Debug, CAC	I/O ports	Ex. Bus, SDRAM	Ex. Interrupt	SCI/IIC/I3C/SPI/CANFD/USBFS/USBHS/OSPI/SSIE/SDHI/MMC/EHTERC(MII,RMII)	GPT/AGT/ULPT/RTC	ADC12/DAC12/ACMPHS	MIPI, GLCDC, CEU
B4	B4	81	81	TDATA2	P305	A6/A6	IRQ8	SD0WP/ET0_RX_ER/ RMII0_TXD1_A	GTOVUP/ ULPTEE1	-	-
A3	A3	82	82	TDATA3	P304	A5/A5	IRQ9	SD0DAT0_B/ET0_ETXD1/ RMII0_TXD0_A	GTOVLO/ GTIOC7A/ ULPTO1	-	-
G7	G7	83	83	VSS	-	-	-	-	-	-	-
G9	G9	84	84	VCC	-	-	-	-	-	-	-
C5	C5	-	-	-	P915	-	-	-	GTIOC5A	-	LCD_DATA1_B
F6	F6	-	-	-	P914	-	-	-	GTIOC5B	-	LCD_DATA0_B
C4	C4	85	85	-	P303	A4/A4	-	SD0DAT1_B/ET0_ETXD0/ REF50CK0_A	GTIOC7B	-	LCD_DATA14_A
B3	B3	86	86	-	P302	A3/A3	IRQ5	SD0DAT2_B/ET0_ERXD1/ RMII0_RXD0_A	GTOUUP/ GTIOC4A/ ULPTO0-DS	-	LCD_DATA13_A
A2	A2	87	87	-	P301	A2/A2	IRQ6	SD0DAT3_B/ET0_ERXD0/ RMII0_RXD1_A	GTOULO/ GTIOC4B/ GTIO0/ ULPTEE0-DS	-	LCD_DATA12_A
D5	D5	88	88	-	P300	A1/A1/DQM3	IRQ4	SCK0_A/DE0/SSLA3_B/ ET0_RX_CLK/RMII0_RX_ER_A	GTIOC3A/ ULPTEV10-DS	-	LCD_DATA11_A
B2	B2	89	89	-	P112	A0/BC0/A0/DQM1	-	TXD0_A/MOSI0_A/SDA0_A/ SSLA2_B/SSIBCK0_B/ET0_CRS/ RMII0_CRS_DV_A	GTIOC3B/ ULPTOB0-DS	-	LCD_DATA10_A
C3	C3	90	90	-	P113	CS1/CKE	-	RXD0_A/MISO0_A/SCL0_A/ SSLA1_B/SSILRCK0/SSIFS0_B/ ET0_EXOUT/ET0_EXOUT	GTIOC2A/ ULPTOA0-DS	-	LCD_DATA9_A
C2	C2	91	91	-	P114	CS0/WE	-	CTS0_RTS0_A/SS0_A/DE0/ SSLA0_B/SSIRXD0_B/ ET0_LINKSTA/ET0_LINKSTA	GTIOC2B	-	LCD_DATA8_A
D3	D3	92	92	-	P115	SDCS	-	CTS0_A/MOSIA_B/SSITXD0_B/ ET0_WOL/ET0_WOL	GTIOC5A	-	LCD_DATA7_A
B1	B1	93	93	-	P609	D8[A8/D8]/DQ8	-	TXD0_C/MOSI0_C/SDA0_C/ MISOA_B/CTX1/ET0_RX_DV	GTIOC5B/ ULPTOA1-DS	-	LCD_DATA6_A
D4	D4	-	-	-	PA11	WR2/BC2/DQM2	-	-	GTIOC6A	-	-
D2	D2	-	-	-	PA12	D16/DQ16	-	-	GTIOC6B	-	-
E5	E5	-	-	-	PA13	D17/DQ17	-	-	-	-	-
C1	C1	-	-	-	PA14	D18/DQ18	-	TXD9_C/MOSI9_C/SDA9_C	-	-	-
-	-	94	94	VCC	-	-	-	-	-	-	-
H7	H7	95	95	VSS	-	-	-	-	-	-	-
E4	E4	96	96	-	P610	D9[A9/D9]/DQ9	-	RXD0_C/MISO0_C/SCL0_C/ RSPCKA_B/CRX1/ET0_COL	GTIOC4A/ ULPTOB1-DS	-	LCD_DATA5_A
D1	D1	97	97	CLKOUT/CACREF	P611	D10[A10/D10]/DQ10	-	SCK0_C/DE0/MOSIA_B/ ET0_ERXD2	GTIOC4B	-	LCD_DATA4_A
F3	F3	98	98	-	P612	D11[A11/D11]/DQ11	-	CTS_RTS0_C/SS0_C/DE0/ SSLA0_B/ET0_ERXD3	-	-	LCD_DATA3_A
E2	E2	99	99	-	P613	D12[A12/D12]/DQ12	-	CTS0_C	GTETRGA/ AGTO1	-	LCD_DATA2_A
F4	F4	100	100	-	P614	D13[A13/D13]/DQ13	-	-	GTETRGB/ AGTO0	-	LCD_DATA1_A
E3	E3	101	101	-	P615	D14[A14/D14]/DQ14	IRQ7	USB_VBUSEN	GTETRGC	-	LCD_DATA0_A
G3	G3	102	102	-	PA08	D15[A15/D15]/DQ15	IRQ6	-	GTETRGD	-	LCD_TCON3_A
E1	E1	103	103	-	PA09	EBCLK/SDCLK	IRQ5	-	-	-	LCD_TCON2_A
F2	F2	104	104	-	PA10	WR/WR0/DQM0	IRQ4	-	-	-	LCD_TCON1_A
F5	F5	-	-	-	PA15	D19/DQ19	-	RXD9_C/MISO9_C/SCL9_C	-	-	-
J5	J5	-	-	-	P813	D20/DQ20	-	-	-	-	-
G5	G5	-	-	-	PA07	D21/DQ21	-	-	GTIOC7A	-	-
L5	L5	-	-	-	PA06	D22/DQ22	-	CTS2_C	GTIOC7B	-	-
H5	H5	-	-	-	PA05	D23/DQ23	-	CTS_RTS2_C/SS2_C/DE2	-	-	-
L6	L6	-	-	-	PA04	D24/DQ24	-	SCK2_C/DE2	-	-	-
G4	G4	-	-	-	PA03	D25/DQ25	-	TXD2_C/MOSI2_C/SDA2_C	-	-	-
K6	K6	-	-	-	PA02	D26/DQ26	-	RXD2_C/MISO2_C/SCL2_C	-	-	-

Table 1.15 Pin list (5 of 7)

BGA224	BGA224 without MIPI	LQFP176	LQFP176 without MIPI	Power, System, Clock, Debug, CAC	I/O ports	Ex. Bus, SDRAM	Ex. Interrupt	SCI/IIC/I3C/SPI/CANFD/USBFS/USBHS/OSPI/SSIE/SDHI/MMC/EHTERC(MII,RMII)	GPT/AGT/ULPT/RTC	ADC12/DAC12/ACMPHS	MIPI, GLCDC, CEU
J7	J7	105	105	VSS	-	-	-	-	-	-	-
J6	J6	106	106	VCC	-	-	-	-	-	-	-
H3	H3	107	107	-	PA01	RD	-	-	-	-	LCD_TCON0_A
H4	H4	108	108	-	PA00	D7[A7/D7]/DQ7	-	-	-	-	LCD_CLK_A
F1	F1	109	109	VCL	-	-	-	-	-	-	-
J4	J4	110	110	-	P607	D6[A6/D6]/DQ6	-	-	-	-	LCD_EXTCLK_A
G1	G1	111	111	VCC_DCDC	-	-	-	-	-	-	-
G2	G2	112	112	VCC_DCDC	-	-	-	-	-	-	-
H1	H1	113	113	VLO	-	-	-	-	-	-	-
H2	H2	114	114	VLO	-	-	-	-	-	-	-
J1	J1	115	115	VSS_DCDC	-	-	-	-	-	-	-
M5	M5	116	116	-	P606	D5[A5/D5]/DQ5	-	-	-	-	-
K5	K5	117	117	-	P605	D4[A4/D4]/DQ4	-	CTS0_B	GTIOC8A	-	-
N4	N4	118	118	-	P604	D3[A3/D3]/DQ3	-	CTS_RTS0_B/SS0_B/DE0	GTIOC8B	-	-
M4	M4	119	119	-	P603	D2[A2/D2]/DQ2	-	TXD0_B/MOSI0_B/SDA0_B	GTIOC7A/ULPT00	-	-
L4	L4	120	120	-	P602	D1[A1/D1]/DQ1	-	RXD0_B/MISO0_B/SCL0_B	GTIOC7B/ULPTEE0	-	-
K4	K4	121	121	-	P601	D0[A0/D0]/DQ0	-	SCK0_B/DE0/OM_WP1	GTIOC6A/ULPTEV10/RTCOUT	-	-
K3	K3	122	122	CACREF	P600	-	-	OM_RST01	GTIOC6B/ULPTEV11-DS	-	-
K1	K1	123	123	-	P107	-	-	OM_CS0	GTOWUP/GTIOC8A/AGTOA0	-	-
K2	K2	124	124	-	P106	-	-	SSLB3_A/OM_RESET	GTOWLO/GTIOC8B/AGTOB0/ULPTEE1-DS	-	-
L3	L3	125	125	-	P105	-	IRQ0	SSLB2_A/OM_ECSINT1	GTIOC1A/ULPT01-DS	-	-
L1	L1	126	126	-	P104	-	IRQ1	CTS9_A/SSLB1_A/OM_CS1	GTETRGB/GTIOC1B	-	-
L2	L2	127	127	-	P103	-	-	CTS9_RTS9_A/SS9_A/DE9/SSLB0_A/CTX0/OM_SIO2	GTOWUP/GTIOC2A	-	-
M1	M1	128	128	-	P102	-	-	TXD9_A/MOSI9_A/SDA9_A/RSPCKB_A/CRX0/OM_SIO4	GTOWLO/GTIOC2B/AGTO0	ADTRG0	-
M2	M2	129	129	-	P101	-	IRQ1	RXD9_A/MOSI9_A/SCL9_A/MOSIB_A/OM_SIO3	GTETRGB/GTIOC8A/AGTEE0	-	-
J3	J3	130	130	VCC2	-	-	-	-	-	-	-
J2	J2	131	131	VSS	-	-	-	-	-	-	-
N1	N1	132	132	-	P100	-	IRQ2	SCK9_A/DE9/MISOB_A/OM_SIO0	GTETRGA/GTIOC8B/AGTIO0	-	-
M3	M3	133	133	-	P800	-	IRQ11	CTS2_A/OM_SIO5	GTIU/GTIOC11A/AGTOA0	-	-
N2	N2	134	134	-	P801	-	IRQ12	TXD2_A/MOSI2_A/SDA2_A/OM_DQS	GTIV/GTIOC11B/AGTOB0	-	-
P1	P1	135	135	-	P802	-	-	RXD2_A/MISO2_A/SCL2_A/OM_SIO6	GTIW/GTIOC12A	-	-
N3	N3	136	136	-	P803	-	-	SCK2_A/DE2/OM_SIO1	GTETRGC/GTIOC12B	-	-
P2	P2	137	137	-	P804	-	IRQ14	CTS_RTS2_A/SS2_A/DE2/OM_SIO7	GTETRGD/GTIOC13A	-	-
R1	R1	138	138	-	P808	-	IRQ15	OM_SCLK	GTIOC13B	-	-
R2	R2	139	139	-	P809	-	-	OM_SCLKN	-	-	-
P3	P3	140	140	VCC2	-	-	-	-	-	-	-
R3	R3	141	141	VSS	-	-	-	-	-	-	-
P4	P4	142	142	-	P810	-	-	SD1CLK_A	ULPT0A0	-	-

Table 1.15 Pin list (6 of 7)

BGA224	BGA224 without MIPI	LQFP176	LQFP176 without MIPI	Power, System, Clock, Debug, CAC	I/O ports	Ex. Bus, SDRAM	Ex. Interrupt	SCI/IIC/I3C/SPI/CANFD/USBFS/USBHS/OSPI/SSIE/SDHI/MMC/EHTERC(MII,RMII)	GPT/AGT/ULPT/RTC	ADC12/DAC12/ACMPHS	MIPI, GLCDC, CEU
M6	M6	143	143	-	P811	-	-	USB_ID/SD1CMD_A	ULPTOB0	-	-
R4	R4	144	144	-	P812	-	-	USB_EXICEN/SD1DAT0_A	-	AN122	-
P5	P5	145	145	CACREF	P500	-	-	USB_VBUSEN/SD1DAT1_A	-	AN121	-
R5	R5	146	146	-	P501	-	-	USB_OVRCURA/SD1DAT2_A	-	AN120	-
P6	P6	147	147	-	P502	-	-	USB_OVRCURB/SD1DAT3_A	-	AN019/AN119	-
K7	K7	-	-	-	P503	-	-	SD1CD	-	-	-
N5	N5	-	-	-	P504	-	-	SD1WP	-	-	-
K8	K8	-	-	-	P505	D27/DQ27	-	SD1DAT4_A	-	-	-
N6	N6	-	-	-	P506	D28/DQ28	-	SD1DAT5_A	-	-	-
L7	L7	-	-	-	P507	D29/DQ29	-	SD1DAT6_A	-	-	-
M7	M7	-	-	-	P508	D30/DQ30	IRQ1	SD1DAT7_A	-	-	-
L8	L8	-	-	-	P509	D31/DQ31	IRQ2	-	ULPTEV1	-	-
N7	N7	-	-	-	P510	WR3/BC3	IRQ3	-	ULPTEV0	-	-
R6	R6	148	148	VCL	-	-	-	-	-	-	-
J9	J9	149	149	VCC	-	-	-	-	-	-	-
J8	J8	150	150	VSS	-	-	-	-	-	-	-
R7	R7	151	151	-	P015	-	IRQ13	-	-	AN105/DA1	-
P7	P7	152	152	-	P014	-	-	-	-	AN007/DA0	-
P8	P8	153	153	VREFL	-	-	-	-	-	-	-
R8	R8	154	154	VREFH	-	-	-	-	-	-	-
N8	N8	155	155	AVCC0	-	-	-	-	-	-	-
N9	N9	156	156	AVSS0	-	-	-	-	-	-	-
P9	P9	157	157	VREFL0	-	-	-	-	-	-	-
R9	R9	158	158	VREFH0	-	-	-	-	-	-	-
M9	M9	-	-	-	P011	-	-	-	-	AN106	-
M8	M8	159	159	-	P010	-	IRQ14	-	-	AN005/IVCMP0	-
L9	L9	160	160	-	P009	-	IRQ13-DS	-	-	AN006	-
R10	R10	161	161	-	P008	-	IRQ12-DS	-	-	AN008	-
M10	M10	162	162	-	P007	-	-	-	-	AN004	-
R11	R11	163	163	-	P006	-	IRQ11-DS	-	-	AN002/IVCMP3	-
N10	N10	164	164	-	P005	-	IRQ10-DS	-	-	AN001	-
P10	P10	165	165	-	P004	-	IRQ9-DS	-	-	AN000/IVCMP2	-
P11	P11	166	166	-	P003	-	-	-	-	AN104/IVREF1	-
R12	R12	167	167	-	P002	-	IRQ8-DS	-	-	AN102/IVCMP3	-
P12	P12	168	168	-	P001	-	IRQ7-DS	-	-	AN101/IVREF0	-
R13	R13	169	169	-	P000	-	IRQ6-DS	-	-	AN100/IVCMP2	-
H6	H6	-	-	VCL	-	-	-	-	-	-	-
H8	H8	170	170	VSS	-	-	-	-	-	-	-
H9	H9	171	171	VCC	-	-	-	-	-	-	-
N11	N11	172	172	-	P806	-	IRQ0	-	-	AN018/AN118	LCD_CLK_B/ VIO_D14
M11	M11	173	173	-	P805	-	-	-	-	AN017/AN117	LCD_TCON0_B/ VIO_D15
N12	N12	-	-	-	P807	-	-	-	-	-	LCD_TCON1_B
P13	P13	174	174	-	P513	-	-	-	-	AN016/ AN116/ IVCMP0	LCD_TCON2_B/ VIO_FLD
R14	R14	-	-	-	P515	-	-	-	-	-	LCD_TCON3_B

Table 1.15 Pin list (7 of 7)

BGA224	BGA224 without MIPI	LQFP176	LQFP176 without MIPI	Power, System, Clock, Debug, CAC	I/O ports	Ex. Bus, SDRAM	Ex. Interrupt	SCI/IIC/I3C/SPI/CANFD/USBFS/USBHS/OSPI/SSIE/SDHI/MMC/EHTERC(MII,RMII)	GPT/AGT/ULPT/RTC	ADC12/DAC12/ACMPHS	MIPI, GLCDC, CEU
N13	N13	175	175	-	P512	-	IRQ14	SCL1_A/CTX1	GTIOC0A	-	-
P14	P14	-	-	-	P514	-	-	-	-	-	LCD_EXTCLK_B
K9	K9	176	176	-	P511	-	IRQ15	SDA1_A/CRX1	GTIOC0B	-	-

Note: Several pin names have the added suffix of _A, _B, and _C. These suffixes have special conditions for electrical characteristics.

2. Electrical Characteristics

Unless otherwise specified, minimum and maximum values are guaranteed by either design simulation, characterization results or test in production.

Supported peripheral functions and pins differ from one product name to another.

Unless otherwise specified, the electrical characteristics of the MCU are defined under the following conditions:

- $VCC = VCC_DCDC = VCC_USB = VBATT = 1.68$ to 3.6 V
- $VCC2 = 1.65$ to 3.6 V
- $AVCC0 = 1.65$ to 3.6 V
- $VCC_USBHS = AVCC_USBHS = 3.0$ to 3.6 V
- $AVCC_MIPI = 3.0$ to 3.6 V
- $VREFH0 = 2.7$ V to $AVCC0$
- $VREFH = 1.65$ V to $AVCC0$
- $VCC18_MIPI = 1.7$ to 1.9 V
- $VSS = VSS_DCDC = AVSS0 = VREFL0 / VREFL = VSS_USB = VSS1_USBHS = VSS2_USBHS = VSS_MIPI = 0$ V
- VCC voltage is lower than 2.7 V : $LVOCR.LVO0E = 1$, otherwise $LVOCR.LVO0E = 0$
- $VCC2$ voltage is lower than 2.7 V : $LVOCR.LVO1E = 1$, otherwise $LVOCR.LVO1E = 0$
- $T_j = T_{opj}$

When not specified otherwise, typical values are measured at room temperature of 25 °C and $VCC = VCC_DCDC = VCC_USB = VBATT = VCC_USBHS = AVCC_USBHS = AVCC0 = AVCC_MIPI = VREFH0 = VREFH = 3.3$ V, $VCC18_MIPI = 1.8$ V.

Figure 2.1 shows the timing conditions.

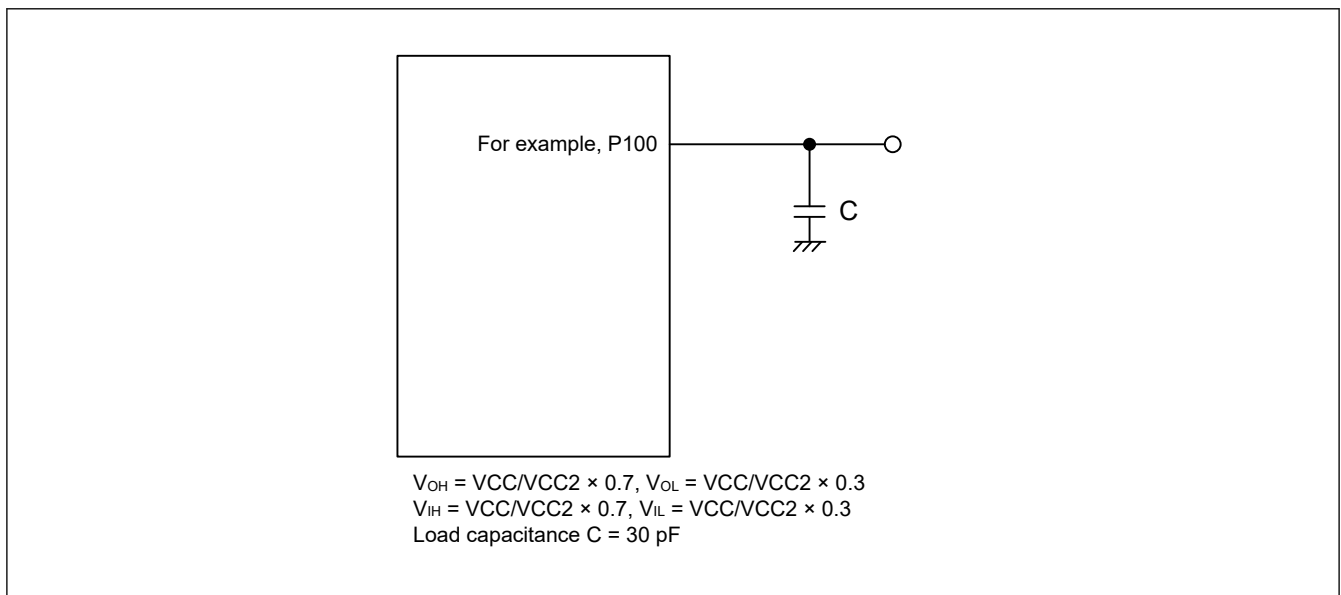

Figure 2.1 Input or output timing measurement conditions

The recommended measurement conditions for the timing specification of each peripheral provided are for the best peripheral operation. Make sure to adjust the driving abilities of each pin to meet your conditions.

2.1 Absolute Maximum Ratings

Table 2.1 Absolute maximum ratings

Parameter	Symbol	Value	Unit
Power supply voltage	VCC, VCC2, VCC_DCDC, VCC_USB ^{*2}	-0.3 to +4.0	V
External power supply voltage	VCL	-0.3 to +1.6	V
VBATT power supply voltage	VBATT	-0.3 to +4.0	V
Input voltage (except for 5 V-tolerant ports ^{*1})	V _{in}	-0.3 to VCC + 0.3 or -0.3 to VCC2 + 0.3	V
Input voltage (5 V-tolerant ports ^{*1})	V _{in}	-0.3 to + VCC + 4.0 (max. 5.8)	V
Reference power supply voltage	VREFH/VREFH0	-0.3 to AVCC0 + 0.3	V
USBHS power supply voltage	VCC_USBHS	-0.3 to +4.0	V
USBHS analog power supply voltage	AVCC_USBHS	-0.3 to +4.0	V
MIPI PHY analog power supply voltage	AVCC_MIPI	-0.3 to +4.0	V
MIPI PHY power supply voltage	VCC18_MIPI	-0.3 to +2.5	V
MIPI_DL0_P and MIPI_DL0_N input voltage	V _{PIN}	-0.5 to VCC18_MIPI + 0.5	V
Analog power supply voltage	AVCC0	-0.3 to +4.0	V
Analog input voltage	V _{AN}	-0.3 to AVCC0 + 0.3	V
Operating junction temperature ^{*3 *4}	T _{opj}	-40 to +125	°C
Storage temperature	T _{stg}	-55 to +125	°C

Note 1. Ports P205, P206, P402 to P404, P406 to P415, P511, P512, P709 to P715 and PB01 are 5 V tolerant.

Note 2. Connect VCC_DCDC and VCC_USB to VCC.

Note 3. See [section 2.2.1. Tj/Ta Definition](#).

Note 4. Contact a Renesas Electronics sales office for information on derating operation when T_j = +105°C to +125°C. Derating is the systematic reduction of load for improved reliability.

Caution: Permanent damage to the MCU might result if absolute maximum ratings are exceeded.

Table 2.2 Recommended operating conditions (1 of 2)

Parameter	Symbol	Min	Typ	Max	Unit	
Power supply voltages	VCC, VCC_DCDC	Other than the following	1.68	—	3.60	V
		When ETHERC/IIC Fast-mode + is used	2.70	—	3.60	V
		When USB/SDRAM is used	3.00	—	3.60	V
	VCC2	1.65	—	3.60	V	
	VCL	When external VDD is used ^{*2}	1.20	—	1.25	V
		When DCDC is used (High-speed mode)	—	1.21	—	V
		When DCDC is used (Low-speed mode or Software Standby mode)	—	1.18	—	V
VSS, VSS_DCDC	—	0	—	V		
USB power supply voltages	VCC_USB, VCC_USBHS, AVCC_USBHS	—	VCC	—	V	
	VSS_USB, VSS1_USBHS, VSS2_USBHS	—	0	—	V	
MIPI PHY power supply voltages	VCC18_MIPI	1.70	1.80	1.90	V	
	AVCC_MIPI	3.00	—	3.60	V	
	VSS_MIPI	—	0	—	V	
VBATT power supply voltage	VBATT	1.62	—	3.60	V	

Table 2.2 Recommended operating conditions (2 of 2)

Parameter	Symbol	Min	Typ	Max	Unit	
Analog power supply voltages	AVCC0*1	When ADC is not used	1.65	—	3.60	V
		When ADC is used	2.70	—	3.60	V
	AVSS0	—	0	—	V	

Note 1. When the A/D converter, the D/A converter and the High-Speed Analog Comparator are not in use, do not leave the AVCC0, VREFH/VREFH0, AVSS0, and VREFL/VREFL0 pins open. Connect the AVCC0 and VREFH/VREFH0 pins to VCC, and the AVSS0 and VREFL/VREFL0 pins to VSS, respectively.

Note 2. VCL voltage must never be higher than VCC voltage.

2.2 DC Characteristics

2.2.1 T_j/T_a Definition

Table 2.3 DC characteristics

Parameter	Symbol	Typ	Max	Unit	Test conditions
Permissible operating junction temperature	T _j	—	125	°C	High-speed mode Low-speed mode

Note: Make sure that $T_j = T_a + \theta_{ja} \times \text{total power consumption (W)}$, where total power consumption = $(V_{CC} - V_{OH}) \times \Sigma I_{OH} + V_{OL} \times \Sigma I_{OL} + (I_{CCmax} + I_{CC_DCDCmax}) \times V_{CC}$.

Note: Minimum Ambient Temperature(T_a) is -40°C

2.2.2 I/O V_{IH} , V_{IL} Table 2.4 I/O V_{IH} , V_{IL} except for Schmitt trigger input pins

Parameter		VCC/VCC2/ AVCC0	Symbol	Min	Typ	Max	Unit
Peripheral function pins	EXTAL (external clock input), WAIT, SPI ^{*1} (except RSPCK)	1.68 V or above	V_{IH}	$VCC \times 0.8$	—	—	V
			V_{IL}	—	—	$VCC \times 0.2$	
	SPI ^{*2} (except RSPCKB_A)	1.65 V or above	V_{IH}	$VCC2 \times 0.8$	—	—	
			V_{IL}	—	—	$VCC2 \times 0.2$	
	OSPI (except OM_RSTO1 and OM_ECSINT1)	2.70 V or above	V_{IH}	$VCC2 \times 0.8$	—	—	
			V_{IL}	—	—	$VCC2 \times 0.2$	
		1.65 V or above	V_{IH}	$VCC2 \times 0.7$	—	$VCC2 + 0.3$	
			V_{IL}	$VSS - 0.3$	—	$VCC2 \times 0.3$	
	SD ^{*3}	2.70 V or above	V_{IH}	$VCC \times 0.625$	—	$VCC + 0.3$	
			V_{IL}	$VSS - 0.3$	—	$VCC \times 0.25$	
		1.70 V ~ 1.95 V	V_{IH}	1.27	—	2	
			V_{IL}	$VSS - 0.3$	—	0.58	
	SD ^{*4}	2.70 V or above	V_{IH}	$VCC2 \times 0.625$	—	$VCC2 + 0.3$	
			V_{IL}	$VSS - 0.3$	—	$VCC2 \times 0.25$	
		1.70 V ~ 1.95 V	V_{IH}	1.27	—	2	
			V_{IL}	$VSS - 0.3$	—	0.58	
	MMC ^{*5}	2.70 V or above	V_{IH}	$VCC \times 0.625$	—	$VCC + 0.3$	
			V_{IL}	$VSS - 0.3$	—	$VCC \times 0.25$	
		1.70 V ~ 1.95 V	V_{IH}	$VCC \times 0.65$	—	$VCC + 0.3$	
			V_{IL}	$VSS - 0.3$	—	$VCC \times 0.35$	
MMC ^{*6}	2.70 V or above	V_{IH}	$VCC2 \times 0.625$	—	$VCC2 + 0.3$		
		V_{IL}	$VSS - 0.3$	—	$VCC2 \times 0.25$		
	1.70 V ~ 1.95 V	V_{IH}	$VCC2 \times 0.65$	—	$VCC2 + 0.3$		
		V_{IL}	$VSS - 0.3$	—	$VCC2 \times 0.35$		
D00 to D31, TMS, TDI, TCK, SWDIO, SWCLK	1.68 V or above	V_{IH}	$VCC \times 0.7$	—	—		
		V_{IL}	—	—	$VCC \times 0.3$		
DQ00 to DQ31	3.00 V or above	V_{IH}	$VCC \times 0.7$	—	—		
		V_{IL}	—	—	$VCC \times 0.3$		
ETHERC	2.70 V or above	V_{IH}	2.3	—	—		
		V_{IL}	—	—	$VCC \times 0.2$		
IIC (SMBus)	2.70 V or above	V_{IH}	2.1	—	$VCC + 3.6$ (max 5.8)		
		V_{IL}	—	—	0.8		
RTCIC0, RTCIC1, RTCIC2, EXCIN when VCC power supply is selected	1.68 V or above	V_{IH}	0.9	—	3.9		
		V_{IL}	—	—	0.3		
RTCIC0, RTCIC1, RTCIC2, EXCIN when VBATT power supply is selected		V_{IH}	0.9	—	3.9		
		V_{IL}	—	—	0.3		

- Note 1. SPI0_A, SPI0_B, SPI0_C and SPI1_B
- Note 2. SPI1_A
- Note 3. SD_A ch0, SD_B ch1 and SD_B ch1
- Note 4. SD_A ch1
- Note 5. MMC_A ch0, MMC_A ch1 and MMC_B ch1
- Note 6. MMC_A ch1 (Up to 4-bit bus width)
- Note 7. RES and peripheral function pins associated with P205, P206, P402 to P404, P406 to P415, P511, P512, P709 to P715, PB01 (total 26 pins).
- Note 8. All input pins except for the peripheral function pins already described in the table. There is an item for each power supply voltage for each port. Refer to the IO chapter for the power supply of the port.
- Note 9. P205, P206, P402 to P404, P406 to P415, P511, P512, P709 to P715, PB01 (total 25 pins).
- Note 10. All input pins except for the ports already described in the table. There is an item for each power supply voltage for each port. Refer to the IO chapter for the power supply of the port.
- Note 11. When VCC is less than 1.68 V, the input voltage of 5 V-tolerant ports should be less than 3.6 V, otherwise breakdown may occur because 5 V-tolerant ports are electrically controlled so as not to violate the break down voltage.

Table 2.5 I/O V_{IH}, V_{IL} of Schmitt trigger input pins

Parameter		VCC/VCC2/ AVCC0	Symbol	Min	Typ	Max	Unit
Peripheral function pins	IIC (except for SMBus)	1.68 V or above	V _{IH}	VCC × 0.7	—	VCC + 3.6 (max 5.8)	V
			V _{IL}	—	—	VCC × 0.3	
			ΔV _T	VCC × 0.05	—	—	
	I3C	1.68 V or above	V _{IH}	VCC × 0.7	—	VCC + 0.3	
			V _{IL}	—	—	VCC × 0.3	
			ΔV _T	VCC × 0.1	—	—	
	5 V-tolerant ports ^{*7*11}	1.68 V or above	V _{IH}	VCC × 0.8	—	VCC + 3.6 (max 5.8)	
			V _{IL}	—	—	VCC × 0.2	
			ΔV _T	VCC × 0.05	—	—	
	Other VCC input pins ^{*8}	1.68 V or above	V _{IH}	VCC × 0.8	—	—	
			V _{IL}	—	—	VCC × 0.2	
			ΔV _T	VCC × 0.05	—	—	
	Other VCC2 input pins ^{*8}	1.65 V or above	V _{IH}	VCC2 × 0.8	—	—	
			V _{IL}	—	—	VCC2 × 0.2	
			ΔV _T	VCC2 × 0.05	—	—	
	Other AVCC0 input pins ^{*8}	1.65 V or above	V _{IH}	AVCC0 × 0.8	—	—	
			V _{IL}	—	—	AVCC0 × 0.2	
			ΔV _T	AVCC0 × 0.05	—	—	
Ports	5 V-tolerant port ^{*9*11}	1.68 V or above	V _{IH}	VCC × 0.8	—	VCC + 3.6 (max 5.8)	
			V _{IL}	—	—	VCC × 0.2	
	Other VCC input pins ^{*10}	1.68 V or above	V _{IH}	VCC × 0.8	—	—	
			V _{IL}	—	—	VCC × 0.2	
	Other VCC2 input pins ^{*10}	1.65 V or above	V _{IH}	VCC2 × 0.8	—	—	
			V _{IL}	—	—	VCC2 × 0.2	
	Other AVCC0 input pins ^{*10}	1.65 V or above	V _{IH}	AVCC0 × 0.8	—	—	
			V _{IL}	—	—	AVCC0 × 0.2	

- Note 1. SPI0_A, SPI0_B, SPI0_C and SPI1_B
- Note 2. SPI1_A
- Note 3. SD_A ch0, SD_B ch1 and SD_B ch1
- Note 4. SD_A ch1
- Note 5. MMC_A ch0, MMC_A ch1 and MMC_B ch1
- Note 6. MMC_A ch1 (Up to 4-bit bus width)

- Note 7. RES and peripheral function pins associated with P205, P206, P402 to P404, P406 to P415, P511, P512, P709 to P715, PB01 (total 26 pins).
- Note 8. All input pins except for the peripheral function pins already described in the table. There is an item for each power supply voltage for each port. Refer to the IO chapter for the power supply of the port.
- Note 9. P205, P206, P402 to P404, P406 to P415, P511, P512, P709 to P715, PB01 (total 25 pins).
- Note 10. All input pins except for the ports already described in the table. There is an item for each power supply voltage for each port. Refer to the IO chapter for the power supply of the port.
- Note 11. When VCC is less than 1.68 V, the input voltage of 5 V-tolerant ports should be less than 3.6 V, otherwise breakdown may occur because 5 V-tolerant ports are electrically controlled so as not to violate the break down voltage.

2.2.3 I/O I_{OH} , I_{OL}

Table 2.6 I/O I_{OH} , I_{OL} (1 of 2)

Parameter			VCC/ VCC2/ AVCC0	Symbol	Min	Typ	Max	Unit		
Permissible output current (average value per pin)	Ports P000 to P011, P014, P015, P201	—	—	I_{OH}	—	—	-2.0	mA		
				I_{OL}	—	—	2.0	mA		
	Ports P205, P206, P402 to P404, P406 to P408, P411 to P415, P709 to P715, PB01 (total 21 pins)	Low drive* ¹	—	—	I_{OH}	—	—	-2.0	mA	
					I_{OL}	—	—	2.0	mA	
		Middle drive* ²	—	—	—	I_{OH}	—	—	-4.0	mA
						I_{OL}	—	—	4.0	mA
		High drive* ³	—	—	—	I_{OH}	—	—	-20	mA
						I_{OL}	—	—	20.0	mA
	Ports P100 to P103, P304 to P308, P800 to P804, P808 to P810, PA09 (total 18 pins)	Low drive* ¹	—	—	I_{OH}	—	—	-2.0	mA	
					I_{OL}	—	—	2.0	mA	
		Middle drive* ²	—	—	—	I_{OH}	—	—	-4.0	mA
						I_{OL}	—	—	4.0	mA
		High drive* ³	—	—	—	I_{OH}	—	—	-16	mA
						I_{OL}	—	—	16.0	mA
		High-speed high drive* ⁴	—	—	—	I_{OH}	—	—	-20	mA
						I_{OL}	—	—	20.0	mA
	Other output pins* ⁵	Low drive* ¹	—	—	I_{OH}	—	—	-2.0	mA	
					I_{OL}	—	—	2.0	mA	
		Middle drive* ²	—	—	—	I_{OH}	—	—	-4.0	mA
						I_{OL}	—	—	4.0	mA
High drive* ³		—	—	—	I_{OH}	—	—	-16	mA	
					I_{OL}	—	—	16.0	mA	

Table 2.6 I/O I_{OH} , I_{OL} (2 of 2)

Parameter			VCC/ VCC2/ AVCC0	Symbol	Min	Typ	Max	Unit	
Permissible output current (max value per pin)	Ports P000 to P011, P014, P015, P201	—	—	I_{OH}	—	—	-4.0	mA	
				I_{OL}	—	—	4.0	mA	
	Ports P205, P206, P402 to P404, P406 to P408, P411 to P415, P709 to P715, PB01 (total 21 pins)	Low drive* ¹	—	—	I_{OH}	—	—	-4.0	mA
					I_{OL}	—	—	4.0	mA
		Middle drive* ²	—	—	I_{OH}	—	—	-8.0	mA
					I_{OL}	—	—	8.0	mA
		High drive* ³	—	—	I_{OH}	—	—	-40	mA
					I_{OL}	—	—	40.0	mA
	Ports P100 to P103, P304 to P308, P800 to P804, P808 to P810, PA09 (total 18 pins)	Low drive* ¹	—	—	I_{OH}	—	—	-4.0	mA
					I_{OL}	—	—	4.0	mA
		Middle drive* ²	—	—	I_{OH}	—	—	-8.0	mA
					I_{OL}	—	—	8.0	mA
		High drive* ³	—	—	I_{OH}	—	—	-32	mA
					I_{OL}	—	—	32.0	mA
		High-speed high drive* ⁴	—	—	I_{OH}	—	—	-40	mA
					I_{OL}	—	—	40.0	mA
	Other output pins* ⁵	Low drive* ¹	—	—	I_{OH}	—	—	-4.0	mA
					I_{OL}	—	—	4.0	mA
		Middle drive* ²	—	—	I_{OH}	—	—	-8.0	mA
					I_{OL}	—	—	8.0	mA
High drive* ³		—	—	I_{OH}	—	—	-32	mA	
				I_{OL}	—	—	32.0	mA	
Permissible output current (max value of total of all pins)	Maximum of all output pins	VCC I/O	1.68 V or above	$\Sigma I_{OH} (max)$	—	—	-80	mA	
		VCC2 I/O	1.65 V or above		—	—	-80		
		AVCC0 I/O	1.65 V or above		—	—	-33		
		VCC and VCC2 I/O	1.65 V or above	$\Sigma I_{OL} (max)$	—	—	80	mA	
		AVCC0 I/O	1.65 V or above		—	—	33		

Note 1. This is the value when low driving ability is selected in the Port Drive Capability bit in the PmnPFS register. The selected driving ability except for 400 and P401 is retained in Deep Software Standby mode.

Note 2. This is the value when middle driving ability is selected in the Port Drive Capability bit in the PmnPFS register. The selected driving ability except for 400 and P401 is retained in Deep Software Standby mode.

Note 3. This is the value when high driving ability is selected in the Port Drive Capability bit in the PmnPFS register. The selected driving ability except for 400 and P401 is retained in Deep Software Standby mode.

Note 4. This is the value when high-speed high driving ability is selected in the Port Drive Capability in the PmnPFS register. The selected driving ability is retained in Deep Software Standby mode.

Note 5. Except for P200, which is an input port.

Caution: To protect the reliability of the MCU, the output current values should not exceed the values in this table. The average output current indicates the average value of current measured during 100 μ s.

2.2.4 I/O V_{OH} , V_{OL} , and Other CharacteristicsTable 2.7 I/O V_{OH} , V_{OL} , and other characteristics (1 of 3)

Parameter		VCC/VCC2/ AVCC0	Symbol	Min	Typ	Max	Unit	Test conditions	
Output voltage	IIC	2.70 V or above	V_{OL}	—	—	0.4	V	$I_{OL} = 3.0 \text{ mA}$	
			V_{OL}	—	—	0.6		$I_{OL} = 6.0 \text{ mA}$	
		1.68 V or above	V_{OL}	—	—	$VCC \times 0.2$		$I_{OL} = 3.0 \text{ mA}$	
			V_{OL}	—	—	0.6		$I_{OL} = 6.0 \text{ mA}$	
	IIC*1	2.70 V or above	V_{OL}	—	—	0.4		$I_{OL} = 15.0 \text{ mA}$ (ICFER.FMPE = 1)	
			V_{OL}	—	0.4	—		$I_{OL} = 20.0 \text{ mA}$ (ICFER.FMPE = 1)	
	I3C	2.70 V or above	V_{OL}	—	—	0.4		$I_{OL} = 3.0 \text{ mA}$ (PRTS.PRTMD = 1, BFCTL.FMPE = 0, BFCTL.HSME = 0)	
			V_{OL}	—	—	0.6		$I_{OL} = 6.0 \text{ mA}$ (PRTS.PRTMD = 1, BFCTL.FMPE = 0, BFCTL.HSME = 0)	
			V_{OL}	—	—	0.4		$I_{OL} = 15.0 \text{ mA}$ (PRTS.PRTMD = 1, BFCTL.FMPE = 1, BFCTL.HSME = 0)	
			V_{OL}	—	0.4	—		$I_{OL} = 20.0 \text{ mA}$ (PRTS.PRTMD = 1, BFCTL.FMPE = 1, BFCTL.HSME = 0)	
			V_{OL}	—	—	0.4		$I_{OL} = 3.0 \text{ mA}$ (PRTS.PRTMD = 1, BFCTL.FMPE = 0, BFCTL.HSME = 1)	
			V_{OH}	$VCC - 0.27$	—	—		$I_{OH} = 3.0 \text{ mA}$ (PRTS.PRTMD = 0, BFCTL.FMPE = 0, BFCTL.HSME = 0)	
			V_{OL}	—	—	0.27		$I_{OL} = 3.0 \text{ mA}$ (PRTS.PRTMD = 0, BFCTL.FMPE = 0, BFCTL.HSME = 0)	
			1.68 V or above	V_{OL}	—	—		$VCC \times 0.2$	$I_{OL} = 3.0 \text{ mA}$ (PRTS.PRTMD = 1, BFCTL.FMPE = 0, BFCTL.HSME = 0)
				V_{OL}	—	—		0.6	$I_{OL} = 6.0 \text{ mA}$ (PRTS.PRTMD = 1, BFCTL.FMPE = 0, BFCTL.HSME = 0)
				V_{OL}	—	—		$VCC \times 0.2$	$I_{OL} = 3.0 \text{ mA}$ (PRTS.PRTMD = 1, BFCTL.FMPE = 0, BFCTL.HSME = 1)
		V_{OH}		$VCC - 0.27$	—	—		$I_{OH} = 3.0 \text{ mA}$ (PRTS.PRTMD = 0, BFCTL.FMPE = 0, BFCTL.HSME = 0)	
		V _{OL}	—	—	0.27	$I_{OL} = 3.0 \text{ mA}$ (PRTS.PRTMD = 0, BFCTL.FMPE = 0, BFCTL.HSME = 0)			
			—	—	0.27	$I_{OL} = 3.0 \text{ mA}$ (PRTS.PRTMD = 0, BFCTL.FMPE = 0, BFCTL.HSME = 0)			
		ETHERC	2.70 V or above	V_{OH}	$VCC - 0.5$	—		—	$I_{OH} = -1.0 \text{ mA}$
	V_{OL}			—	—	0.4		$I_{OL} = 1.0 \text{ mA}$	
	SD	2.70 V or above	V_{OH}	$VCC \times 0.75$	—	—		$I_{OH} = -2.0 \text{ mA}$	
			V_{OL}	—	—	$VCC \times 0.125$		$I_{OL} = 3.0 \text{ mA}$	
			V_{OH}	$VCC2 \times 0.75$	—	—		$I_{OH} = -2.0 \text{ mA}$	
V_{OL}			—	—	$VCC2 \times 0.125$	$I_{OL} = 3.0 \text{ mA}$			
1.70 V to 1.95 V		V_{OH}	1.4	—	—	$I_{OH} = -2.0 \text{ mA}$			
		V_{OL}	—	—	0.45	$I_{OL} = 2.0 \text{ mA}$			

Table 2.7 I/O V_{OH} , V_{OL} , and other characteristics (2 of 3)

Parameter		VCC/VCC2/ AVCC0	Symbol	Min	Typ	Max	Unit	Test conditions
Output voltage	MMC	2.70 V or above	V_{OH}	$VCC \times 0.75$	—	—	V	$I_{OH} = -0.1 \text{ mA}$ ($VCC = 2.7V$)
			V_{OL}	—	—	$VCC \times 0.125$	$I_{OL} = 0.1 \text{ mA}$ ($VCC = 2.7V$)	
			V_{OH}	$VCC2 \times 0.75$	—	—	$I_{OH} = -0.1 \text{ mA}$ ($VCC2 = 2.7V$)	
			V_{OL}	—	—	$VCC2 \times 0.125$	$I_{OL} = 0.1 \text{ mA}$ ($VCC2 = 2.7V$)	
		1.70 V to 1.95 V	V_{OH}	$VCC - 0.45$	—	—	$I_{OH} = -2.0 \text{ mA}$	
			V_{OL}	—	—	0.45	$I_{OL} = 2.0 \text{ mA}$	
	V_{OH}		$VCC2 - 0.45$	—	—	$I_{OH} = -2.0 \text{ mA}$		
	Ports P205, P206, P402 to P404, P406 to P415, P709 to P715, PA09, PB01 (total 24 pins)	—	V_{OH}	$VCC - 1.0$	—	—	$I_{OH} = -20 \text{ mA}$ $VCC = 3.3 \text{ V}$	
		—	V_{OL}	—	—	1	$I_{OL} = 20 \text{ mA}$ $VCC = 3.3 \text{ V}$	
	Other output pins	1.68 V or above	V_{OH}	$VCC - 0.5$	—	—	$I_{OH} = -1.0 \text{ mA}$	
			V_{OL}	—	—	0.5	$I_{OL} = 1.0 \text{ mA}$	
		1.65V or above	V_{OH}	$VCC2 - 0.5$	—	—	$I_{OH} = -1.0 \text{ mA}$	
			V_{OL}	—	—	0.5	$I_{OL} = 1.0 \text{ mA}$	
			V_{OH}	$AVCC0 - 0.5$	—	—	$I_{OH} = -1.0 \text{ mA}$	
			V_{OL}	—	—	0.5	$I_{OL} = 1.0 \text{ mA}$	
	Input leakage current	RES	1.68 V or above	$ I_{in} $	—	—	5.0	μA
Port P200		—			—	1.0	$V_{in} = 0 \text{ V}$ $V_{in} = VCC$	
Three-state leakage current (off state)	5 V-tolerant ports	1.68 V or above	$ I_{TSI} $	—	—	5.0	μA	$V_{in} = 0 \text{ V}$ $V_{in} = 5.5 \text{ V}$
	Other ports (except for port P200)	1.68 V or above		—	—	1.0	$V_{in} = 0 \text{ V}$ $V_{in} = VCC$	
		1.65 V or above		—	—	1.0	$V_{in} = 0 \text{ V}$ $V_{in} = VCC2, AVCC0$	
Input pull-up MOS current	Ports P0 to PB	2.70 V or above	I_p	-300	—	-10	μA	$VCC, VCC2, AVCC0 = 2.7 \text{ to } 3.6 \text{ V}$ $V_{in} = 0 \text{ V}$
		1.68 V or above		-300	—	-5	μA	$VCC = 1.68 \text{ to } 3.6 \text{ V}$ $V_{in} = 0 \text{ V}$
		1.65 V or above		-300	—	-5	μA	$VCC2, AVCC0 = 1.65 \text{ to } 3.6 \text{ V}$ $V_{in} = 0 \text{ V}$
Pull-up current serving as the SCL current source	I3C ³	3.0 V to 3.6 V	I_{cs}	3	—	12	mA	$VCC = 3.0 \text{ to } 3.6 \text{ V}$ $V_{in} = 0.3 \times VCC \text{ to } 0.7 \times VCC$
		1.68 V to 1.95 V						$VCC = 1.68 \text{ to } 1.95 \text{ V}$ $V_{in} = 0.3 \times VCC \text{ to } 0.7 \times VCC$

Table 2.7 I/O V_{OH} , V_{OL} , and other characteristics (3 of 3)

Parameter		VCC/VCC2/ AVCC0	Symbol	Min	Typ	Max	Unit	Test conditions
Input capacitance	Ports P014, P015	—	C_{in}	—	—	16	pF	Vbias = 0 V Vamp = 20 mV f = 1 MHz Ta = 25°C
	Ports P814/ USB_DP, P815/ USB_DM	—		—	—	12		
	Ports P400, P401, P409, P410, P511, P512, USBHS_DP, USBHS_DM, MIPI_DL0_P, MIPI_DL0_N	—		—	—	10		
	Other input pins	—		—	—	8		

Note 1. SCL0_A, SDA0_A, SCL1_A, SDA1_A (total 4 pins).

Note 2. This is the value when high driving ability is selected in the Port Drive Capability bit in the PmnPFS register.
The selected driving ability is retained in Deep Software Standby mode.

Note 3. I3C_SCL0 (1 pin). This is the value when IIC high speed mode is selected.

2.2.5 Operating and Standby Current

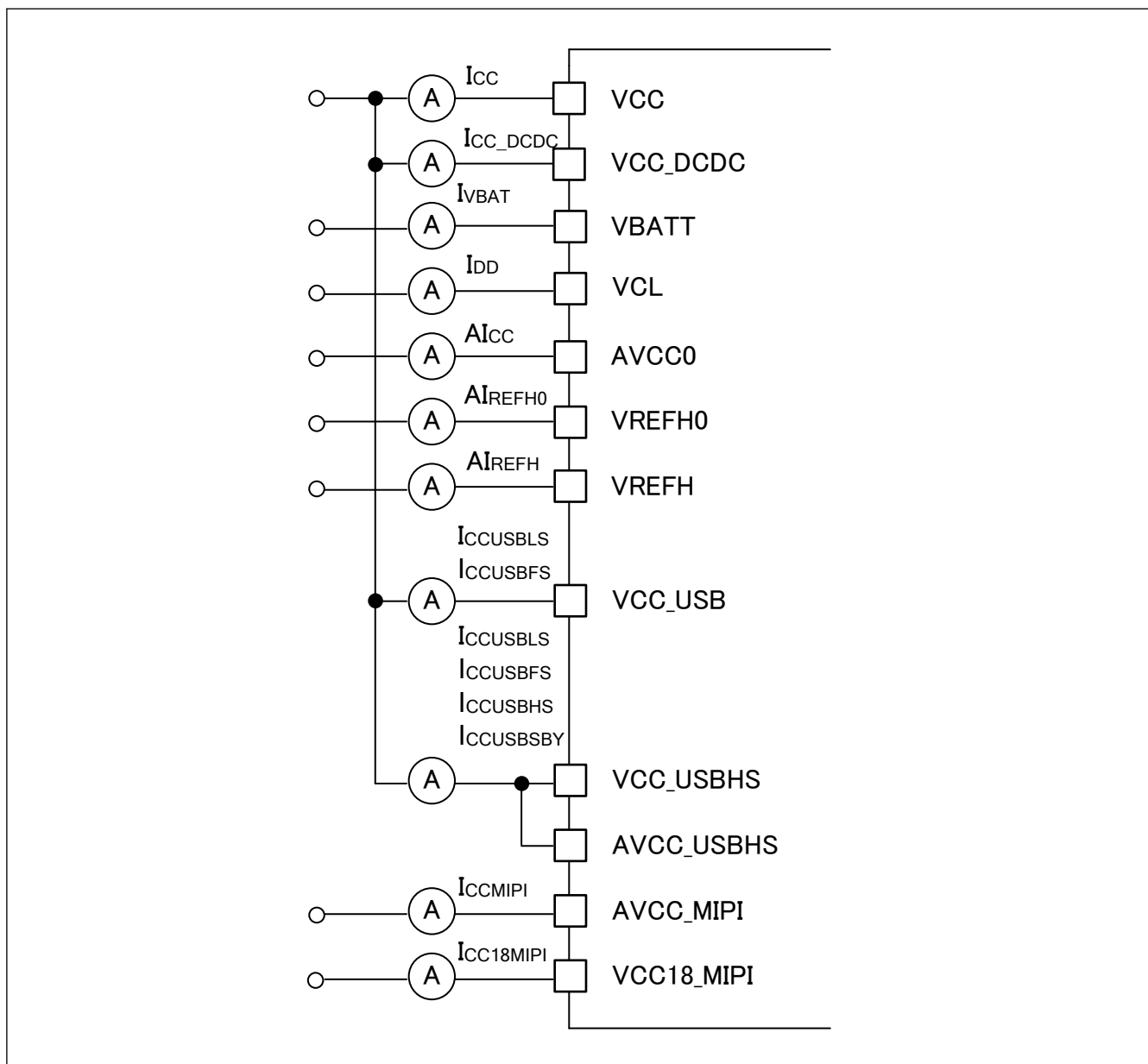

Figure 2.2 Consumption current measurement diagram

Table 2.8 Current of high-speed mode, maximum condition (DCDC mode)

Parameter	Symbol	Typ	Max		Unit	Test conditions	
			105°C	125°C			
Supply current *1*2	—	—	5.97	6.11	mA		
CPUCLK = 480 MHz	VCC_DCD C ≥ 2.5 V	I _{CC_DCDC} ^{*5}	—	303	—	mA	VCC_DCDC = 3.3 V CPUCLK = 480 MHz, ICLK = 240 MHz, PCLKA = 120 MHz, PCLKB = 60 MHz, PCLKC = 60 MHz, PCLKD = 120 MHz, PCLKE = 240 MHz, FCLK = 60 MHz, BCLK = 120 MHz
		I _{DD} ^{*3}	—	624	—		
	VCC_DCD C < 2.5 V	I _{CC_DCDC} ^{*5}	—	320	—	mA	VCC_DCDC = 1.8 V
		I _{DD}	—	400 ^{*4}	—		
CPUCLK = 400 MHz	VCC_DCD C ≥ 2.5 V	I _{CC_DCDC} ^{*5}	—	267	307	mA	VCC_DCDC = 3.3 V CPUCLK = 400 MHz, ICLK = 200 MHz, PCLKA = 100 MHz, PCLKB = 50 MHz, PCLKC = 50 MHz, PCLKD = 100 MHz, PCLKE = 100 MHz, FCLK = 50 MHz, BCLK = 100 MHz
		I _{DD} ^{*3}	—	550	632		
	VCC_DCD C < 2.5 V	I _{CC_DCDC} ^{*5}	—	320	320	mA	VCC_DCDC = 1.8 V
		I _{DD}	—	400 ^{*4}	400 ^{*4}		
CPUCLK = 360 MHz	VCC_DCD C ≥ 2.5 V	I _{CC_DCDC} ^{*5}	—	257	297	mA	VCC_DCDC = 3.3 V CPUCLK = 360 MHz, ICLK = 120 MHz, PCLKA = 120 MHz, PCLKB = 60 MHz, PCLKC = 60 MHz, PCLKD = 120 MHz, PCLKE = 120 MHz, FCLK = 60 MHz, BCLK = 120 MHz
		I _{DD} ^{*3}	—	530	612		
	VCC_DCD C < 2.5 V	I _{CC_DCDC} ^{*5}	—	320	320	mA	VCC_DCDC = 1.8 V
		I _{DD}	—	400 ^{*4}	400 ^{*4}		
CPUCLK = 240 MHz	VCC_DCD C ≥ 2.5 V	I _{CC_DCDC} ^{*5}	—	224	264	mA	VCC_DCDC = 3.3 V CPUCLK = 240 MHz, ICLK = 240 MHz, PCLKA = 120 MHz, PCLKB = 60 MHz, PCLKC = 60 MHz, PCLKD = 120 MHz, PCLKE = 120 MHz, FCLK = 60 MHz, BCLK = 120 MHz
		I _{DD} ^{*3}	—	460	544		
	VCC_DCD C < 2.5 V	I _{CC_DCDC} ^{*5}	—	320	320	mA	VCC_DCDC = 1.8 V
		I _{DD}	—	400 ^{*4}	400 ^{*4}		

Note 1. Supply current values are with all output pins unloaded and all input pull-up MOSs in the off state.

Note 2. Measured with clocks supplied to the peripheral functions and peripherals being operated. This does not include the BGO operation.

Note 3. I_{DD} depends on f (CPUCLK and ICLK) as follows.

I_{DD} Max. (105°C) = 0.68 × f CPUCLK + 0.51 × f ICLK + 180 (unit : mA, fCPUCLK and fICLK are MHz)

I_{DD} Max. (125°C) = 0.68 × f CPUCLK + 0.51 × f ICLK + 258 (unit : mA, fCPUCLK and fICLK are MHz)

Note 4. Do not actual consumption current during operation exceed the current value described here in VCC_DCDC < 2.5V.

Note 5. Typical DCDC efficiency is applied.

Table 2.9 Current of high-speed mode, maximum condition (External VDD mode)

Parameter	CPUCLK Frequency	Symbol	Typ	Max		Unit	Test conditions
				105°C	125°C		
Supply current ^{*1} ^{*2}	—	I _{CC}	—	5.97	6.11	mA	
	CPUCLK = 480 MHz	I _{DD} ^{*3}	—	624	—	mA	CPUCLK = 480 MHz, ICLK = 240 MHz, PCLKA = 120 MHz, PCLKB = 60 MHz, PCLKC = 60 MHz, PCLKD = 120 MHz, PCLKE = 240 MHz, FCLK = 60 MHz, BCLK = 120 MHz
	CPUCLK = 400 MHz	I _{DD} ^{*3}	—	550	632	mA	CPUCLK = 400 MHz, ICLK = 200 MHz, PCLKA = 100 MHz, PCLKB = 50 MHz, PCLKC = 50 MHz, PCLKD = 100 MHz, PCLKE = 100 MHz, FCLK = 50 MHz, BCLK = 100 MHz
	CPUCLK = 360 MHz	I _{DD} ^{*3}	—	530	612	mA	CPUCLK = 360 MHz, ICLK = 120 MHz, PCLKA = 120 MHz, PCLKB = 60 MHz, PCLKC = 60 MHz, PCLKD = 120 MHz, PCLKE = 120 MHz, FCLK = 60 MHz, BCLK = 120 MHz
	CPUCLK = 240 MHz	I _{DD} ^{*3}	—	460	544	mA	CPUCLK = 240 MHz, ICLK = 240 MHz, PCLKA = 120 MHz, PCLKB = 60 MHz, PCLKC = 60 MHz, PCLKD = 120 MHz, PCLKE = 120 MHz, FCLK = 60 MHz, BCLK = 120 MHz

Note 1. Supply current values are with all output pins unloaded and all input pull-up MOSs in the off state.

Note 2. Measured with clocks supplied to the peripheral functions and peripherals being operated. This does not include the BGO operation.

Note 3. I_{DD} depends on f (CPUCLK and ICLK) as follows.

I_{DD} Max. (105°C) = 0.68 × f CPUCLK + 0.51 × f ICLK + 180 (unit : mA, fCPUCLK and fICLK are MHz)

I_{DD} Max. (125°C) = 0.68 × f CPUCLK + 0.51 × f ICLK + 258 (unit : mA, fCPUCLK and fICLK are MHz)

Table 2.10 Current of high-speed mode, maximum data processing, peripheral clock ON (DCDC mode)

Parameter	Symbol	Typ	Max		Unit	Test conditions	
			105°C	125°C			
Supply current ^{*1} ^{*2}	CPUCLK = 480 MHz	I _{CC_DCDC} ^{*4}	—	276	—	mA	VCC_DCDC = 3.3 V ^{*5}
		I _{DD} ^{*3}	—	568	—		
	CPUCLK = 400 MHz	I _{CC_DCDC} ^{*4}	—	246	286		
		I _{DD} ^{*3}	—	506	589		
	CPUCLK = 360 MHz	I _{CC_DCDC} ^{*4}	—	232	272		
		I _{DD} ^{*3}	—	478	561		
	CPUCLK = 240 MHz	I _{CC_DCDC} ^{*4}	—	198	239		
		I _{DD} ^{*3}	—	408	492		

Note 1. Supply current values are with all output pins unloaded and all input pull-up MOSs in the off state.

Note 2. Measured with clocks supplied to the peripheral functions and peripherals being operated. This does not include the BGO operation.

Note 3. I_{DD} depends on f (CPUCLK and ICLK) as follows.

I_{DD} Max. (105°C) = 0.67 × f CPUCLK + 0.30 × f ICLK + 180 (unit : mA, fCPUCLK and fICLK are MHz)

I_{DD} Max. (125°C) = 0.67 × f CPUCLK + 0.30 × f ICLK + 258 (unit : mA, fCPUCLK and fICLK are MHz)

Note 4. Typical DCDC efficiency is applied.

Note 5. Same frequency condition is applied as in the maximum condition.

Table 2.11 Current of high-speed mode, maximum data processing, peripheral clock ON (External VDD mode)

Parameter	Symbol	Typ	Max		Unit	Test conditions
			105°C	125°C		
Supply current ^{*1*2}	CPUCLK = 480 MHz	I_{DD}^{*3}	—	568	—	mA ^{*4}
	CPUCLK = 400 MHz	I_{DD}^{*3}	—	506	589	
	CPUCLK = 360 MHz	I_{DD}^{*3}	—	478	561	
	CPUCLK = 240 MHz	I_{DD}^{*3}	—	408	492	

Note 1. Supply current values are with all output pins unloaded and all input pull-up MOSs in the off state.

Note 2. Measured with clocks supplied to the peripheral functions and peripherals being operated. This does not include the BGO operation.

Note 3. I_{DD} depends on f (CPUCLK and ICLK) as follows.

$$I_{DD} \text{ Max. (105°C)} = 0.67 \times f \text{ CPUCLK} + 0.30 \times f \text{ ICLK} + 180 \text{ (unit : mA, fCPUCLK and fICLK are MHz)}$$

$$I_{DD} \text{ Max. (125°C)} = 0.67 \times f \text{ CPUCLK} + 0.30 \times f \text{ ICLK} + 258 \text{ (unit : mA, fCPUCLK and fICLK are MHz)}$$

Note 4. Same frequency condition is applied as in the maximum condition.

Table 2.12 Current of high-speed mode, maximum data processing, peripheral clock OFF (DCDC mode)

Parameter	Symbol	Typ	Max		Unit	Test conditions
			105°C	125°C		
Supply current ^{*1*2}	CPUCLK = 480 MHz	$I_{CC_DCDC}^{*4}$	—	263	—	mA $V_{CC_DCDC} = 3.3 \text{ V}$ ^{*5}
		I_{DD}^{*3}	—	541	—	
	CPUCLK = 400 MHz	$I_{CC_DCDC}^{*4}$	—	235	274	
		I_{DD}^{*3}	—	483	565	
	CPUCLK = 360 MHz	$I_{CC_DCDC}^{*4}$	—	219	259	
		I_{DD}^{*3}	—	450	533	
	CPUCLK = 240 MHz	$I_{CC_DCDC}^{*4}$	—	184	224	
		I_{DD}^{*3}	—	378	462	

Note 1. Supply current values are with all output pins unloaded and all input pull-up MOSs in the off state.

Note 2. Supply of the clock signal to peripherals is stopped in this state. This does not include the BGO operation.

Note 3. I_{DD} depends on f (CPUCLK and ICLK) as follows.

$$I_{DD} \text{ Max. (105°C)} = 0.68 \times f \text{ CPUCLK} + 0.17 \times f \text{ ICLK} + 180 \text{ (unit : mA, fCPUCLK and fICLK are MHz)}$$

$$I_{DD} \text{ Max. (125°C)} = 0.68 \times f \text{ CPUCLK} + 0.17 \times f \text{ ICLK} + 258 \text{ (unit : mA, fCPUCLK and fICLK are MHz)}$$

Note 4. Typical DCDC efficiency is applied.

Note 5. Same frequency condition is applied as in the maximum condition.

Table 2.13 Current of high-speed mode, maximum data processing, peripheral clock OFF (External VDD mode)

Parameter	Symbol	Typ	Max		Unit	Test conditions
			105°C	125°C		
Supply current ^{*1*2}	CPUCLK = 480 MHz	I_{DD}^{*3}	—	541	—	mA ^{*4}
	CPUCLK = 400 MHz	I_{DD}^{*3}	—	483	565	
	CPUCLK = 360 MHz	I_{DD}^{*3}	—	450	533	
	CPUCLK = 240 MHz	I_{DD}^{*3}	—	378	462	

Note 1. Supply current values are with all output pins unloaded and all input pull-up MOSs in the off state.

Note 2. Supply of the clock signal to peripherals is stopped in this state. This does not include the BGO operation.

Note 3. I_{DD} depends on f (CPUCLK and ICLK) as follows.

$$I_{DD} \text{ Max. (105°C)} = 0.68 \times f \text{ CPUCLK} + 0.17 \times f \text{ ICLK} + 180 \text{ (unit : mA, fCPUCLK and fICLK are MHz)}$$

$$I_{DD} \text{ Max. (125°C)} = 0.68 \times f \text{ CPUCLK} + 0.17 \times f \text{ ICLK} + 226 \text{ (unit : mA, fCPUCLK and fICLK are MHz)}$$

Note 4. Same frequency condition is applied as in the maximum condition.

Table 2.14 Current of high-speed mode, CPU Sleep mode (DCDC mode and External VDD mode)

Parameter		Symbol	Typ	Max		Unit	Test conditions
				105°C	125°C		
Supply current ^{*1*3*4}	CPUCLK = 240 MHz	I _{DD} ^{*2}	29	221	315	mA	—

Note 1. Supply current values are with all output pins unloaded and all input pull-up MOSs in the off state.

Note 2. I_{DD} depends on f (CPUCLK and ICLK) as follows.

$$I_{DD} \text{ Typ. (25°C)} = 0.063 \times f \text{ CPUCLK} + 0.13 \times f \text{ ICLK} + 17.6 \text{ (unit : mA, fCPUCLK and fICLK are MHz)}$$

$$I_{DD} \text{ Max. (105°C)} = 0.063 \times f \text{ CPUCLK} + 0.13 \times f \text{ ICLK} + 180 \text{ (unit : mA, fCPUCLK and fICLK are MHz)}$$

$$I_{DD} \text{ Max. (125°C)} = 0.063 \times f \text{ CPUCLK} + 0.13 \times f \text{ ICLK} + 258 \text{ (unit : mA, fCPUCLK and fICLK are MHz)}$$

Note 3. Supply of the clock signal to peripherals is stopped in this state. This does not include the BGO operation.

Note 4. ICLK, FCLK, BCLK, PCLKA, PCLKB, PCLKC, PCLKD and PCLKE are set to divided by 64.

Table 2.15 Current of high-speed mode, CPU Deep Sleep mode (DCDC mode and External VDD mode)

Parameter		Symbol	Typ	Max		Unit	Test conditions
				105°C	125°C		
Supply current ^{*1*3*4}	CPUCLK = 240 MHz	I _{DD} ^{*2}	12	90	117	mA	—

Note 1. Supply current values are with all output pins unloaded and all input pull-up MOSs in the off state.

Note 2. I_{DD} depends on f (ICLK) as follows.

$$I_{DD} \text{ Typ. (25°C)} = 0.13 \times f \text{ ICLK} + 5.3 \text{ (unit : mA, fCPUCLK and fICLK are MHz)}$$

$$I_{DD} \text{ Max. (105°C)} = 0.13 \times f \text{ ICLK} + 72 \text{ (unit : mA, fCPUCLK and fICLK are MHz)}$$

$$I_{DD} \text{ Max. (125°C)} = 0.13 \times f \text{ ICLK} + 101 \text{ (unit : mA, fCPUCLK and fICLK are MHz)}$$

Note 3. Supply of the clock signal to peripherals is stopped in this state. This does not include the BGO operation.

Note 4. ICLK, FCLK, BCLK, PCLKA, PCLKB, PCLKC, PCLKD and PCLKE are set to divided by 64.

Table 2.16 Increase during BGO operation (DCDC mode and External VDD mode)

Parameter		Symbol	Typ	Max		Unit	Test conditions
				105°C	125°C		
Supply current ^{*1}	Data flash P/E	I _{CC}	6	—	—	mA	—
	Code flash P/E		8	—	—		

Note 1. Supply current values are with all output pins unloaded and all input pull-up MOSs in the off state.

Table 2.17 Current of Low-speed mode (DCDC mode)

Parameter	Symbol	Typ	Max		Unit	Test conditions
			105°C	125°C		
Supply current ^{*1*2*3}	I _{DD}	14.5	—	—	mA	CPUCLK = ICLK = 1MHz Graphics power domain is off

Note 1. Supply current values are with all output pins unloaded and all input pull-up MOSs in the off state.

Note 2. Supply of the clock signal to peripherals is stopped in this state. This does not include the BGO operation.

Note 3. FCLK, BCLK, PCLKA, PCLKB, PCLKC, PCLKD and PCLKE are set to divided by 64 (15.6 kHz).

Table 2.18 Standby current (DCDC mode)

Parameter		Symbol	Typ	Max 125°C	Unit	Test conditions		
Supply current ^{*1}	Software Standby mode ^{*2}	I _{CC}	0.02	0.94	mA	—		
	Data of SRAM and TCM is retained	I _{CC_DCDC}	0.88	28.29		VCC_DCDC = 3.3 V PDRAMSCR0.RKEEPn = 1 (n = 0 to 6) PDRAMSCR1.RKEEP0 = 1		
	Data of SRAM and TCM is not retained	I _{CC_DCDC}	0.83	26.64		VCC_DCDC = 3.3 V PDRAMSCR0.RKEEPn = 0 (n = 0 to 6) PDRAMSCR1.RKEEP0 = 0		
	Deep Software Standby mode 1		I _{CC}	5.21	148	µA	—	
			I _{CC_DCDC}	0.57	5.50		—	
		Increase when the function is activated	Data of Standby SRAM is retained	I _{CC}	0.12		2.60	—
			PVD0, PVD1,PVD2 or Battery power supply switch		See Table 2.20		—	
			When the LOCO is in use		3.10		—	—
			Crystal oscillator and RTC		See Table 2.21		—	
	IWDT and ULPT(all units) are operating	0.07	—	—				
	Deep Software Standby mode 2		I _{CC}	1.68	43.99	µA	—	
			I _{CC_DCDC}	0.57	5.50		—	
Increase when the function is activated		PVD0, PVD1,PVD2 or Battery power supply switch	I _{CC}	See Table 2.20	—			
		Crystal oscillator and RTC		See Table 2.21	—			
Deep Software Standby mode 3		I _{CC}	0.99	42.90	µA	—		
		I _{CC_DCDC}	0.57	5.50		—		
	Increase when the function is activated	Crystal oscillator and RTC		See Table 2.21		—		
RTC operating while VCC is off (with the battery backup function, only the RTC operate)	When a crystal oscillator with low power mode 3 is in use	I _{VBAT}	0.52	—	VBATT=1.8 V, VCC=0 V			
			1.05	—	VBATT=3.3 V, VCC=0 V			
	When a crystal oscillator with low power mode 2 is in use		0.56	—	VBATT=1.8 V, VCC=0 V			
			1.10	—	VBATT=3.3 V, VCC=0 V			
	When a crystal oscillator with low power mode 1 is in use		0.62	—	VBATT=1.8 V, VCC=0V			
			1.17	—	VBATT=3.3 V, VCC=0 V			
	When a crystal oscillator with standard mode is in use		0.93	—	VBATT=1.8 V, VCC=0 V			
			1.50	—	VBATT=3.3 V, VCC=0 V			
	When EXCIN is in use		0.37	—	VBATT=1.8 V, VCC=0 V			
			0.86	—	VBATT=3.3 V, VCC=0 V			
			Increase when the function is activated	Common circuit when using RTCICn (n = 0~2) input or EXCIN	0.04	—	VBATT=1.8 V, VCC=0 V	
				0.04	—	VBATT=3.3 V, VCC=0 V		
RTCICn (n = 0~2) input is in use per channel	0.02	—	VBATT=1.8 V, VCC=0 V					
	0.02	—	VBATT=3.3 V, VCC=0 V					

Note 1. Supply current values are with all output pins unloaded and all input pull-up MOSs in the off state.

Note 2. When an external clock is used, EXTAL pin is pull-up or pull-down. In case clock is toggled, software standby mode current consumption is increased by 130µA at 48MHz under typical conditions.

Table 2.19 Coremark and normal mode current (DCDC and External power supply mode)

Parameter			Symbol	Typ	Max	Unit	Test conditions		
Supply current ^{*1*2}	Coremark	Cache on	I _{DD}	318	—	μA/MHz	CPUCLK = 480 MHz ICLK = 240 MHz PCLKA = 7.5 MHz PCLKB = 7.5 MHz PCLKC = 7.5 MHz PCLKD = 7.5 MHz PCLKE = 7.5 MHz FCLK = 7.5 MHz BCLK = 7.5 MHz		
		Cache off, executing from ITCM		281	—				
		Cache off, executing from SRAM		178	—				
		Cache off, executing from flash		169	—				
	Normal mode	All peripheral disabled, Cache on, while (1) code		223	—				
		All peripheral disabled, Cache off, while (1) code executing from flash		138	—				
	Coremark	Cache off, executing from flash		165	—			μA/MHz	CPUCLK = 360 MHz ICLK = 120 MHz PCLKA = 30 MHz PCLKB = 30 MHz PCLKC = 30 MHz PCLKD = 30 MHz PCLKE = 30 MHz FCLK = 30 MHz BCLK = 30 MHz
	Normal mode	All peripheral disabled, Cache off, while (1) code executing from flash		137	—				

Note 1. Supply current values are with all output pins unloaded and all input pull-up MOSs in the off state.

Note 2. Supply of the clock signal to peripherals is stopped in this state. This does not include the BGO operation.

Table 2.20 Increase when the PVD0, PVD1, PVD2 or Battery power supply switch is enabled in Deep Software Standby mode 1 and 2.

Parameter		Symbol	Typ	Max 125°C	Unit	Test conditions
Supply current	Common circuit when enabling PVDn (n = 0 to 2) or Battery power supply switch in Deep Software Standby mode 1	I _{CC}	4.51	—	μA	—
	Common circuit when enabling PVDn (n = 0 to 2) or Battery power supply switch in Deep Software Standby mode 2		4.97	—		—
	PVD0 enabled with OFS1(_SEC).PVDLPSEL = 1		2.16	—		—
	PVD1 enabled		2.16	—		—
	PVD2 enabled		2.16	—		—
	Battery power supply switch enabled with following conditions.*1		2.16	—		—

Note 1. Consumption current is not increased in other condition.

Table 2.21 Increase when the sub-clock oscillator and RTC are enabled in Deep Software Standby mode 1, 2 and 3.

Parameter			Symbol	Typ	Max 125°C	Unit	Test conditions
Supply current	When a crystal oscillator is in use	Low Power mode 3	I _{CC}	0.22	—	μA	—
		Low Power mode 2		0.27	—		—
		Low Power mode 1		0.34	—		—
		Standard mode		0.67	—		—
	RTC is operating	0.33		—	—		

Table 2.22 Inrush current

Parameter				Symbol	Typ	Max 125°C	Unit	Test conditions
Supply current	Inrush current on returning from deep software standby mode	Inrush current of VCC_DCD C*1	DPSBYCR.DCSSMODE = 0	I _{RUSH}	—	630	mA	—
			DPSBYCR.DCSSMODE = 1		—	1020		—

Note 1. Reference value

Table 2.23 Operating current (Analog) (1 of 2)

Parameter			Symbol	Typ	Max 125 °C	Unit	Test conditions
Supply current *1	Oscillator	Main clock oscillator	I _{CC}	0.48	—	mA	MOMCR.MODRV0[2:0] = 000b
				0.58	—	mA	MOMCR.MODRV0[2:0] = 011b
				0.90	—	mA	MOMCR.MODRV0[2:0] = 101b
Analog power supply current	During 12-bit A/D conversion		AI _{CC}	0.8	1.1	mA	—
	During 12-bit A/D conversion with S/H amp			2.3	3.3	mA	—
	ACMPHS(1unit)			100	150	μA	—
	Temperature sensor			0.1	0.2	mA	—
	During D/A conversion(per unit)	Without AMP output		0.1	0.2	mA	—
		With AMP output		0.8	1.6	mA	—
	Waiting for A/D, D/A conversion (all units)			0.9	1.6	mA	—
	ADC12, DAC12 in standby modes (all units)*2			2	8	μA	—
Reference power supply current (VREFH0)	During 12-bit A/D conversion (unit 0)		AI _{REFH0}	70	120	μA	—
	Waiting for 12-bit A/D conversion (unit 0)			0.07	0.5	μA	—
	ADC12 in standby modes (unit 0)			0.07	0.5	μA	—
Reference power supply current (VREFH)	During 12-bit A/D conversion (unit 1)		AI _{REFH}	70	120	μA	—
	During D/A conversion(per unit)	Without AMP output		0.1	0.4	mA	—
		With AMP output		0.1	0.4	mA	—
	Waiting for 12-bit A/D (unit 1), D/A (all units) conversion			0.07	0.8	μA	—
	ADC12 in standby modes (unit 1)			0.07	0.8	μA	—
USB operating current	Low speed	USBFS	I _{CCUSBLS}	3.5	6.5	μA	VCC_USB
		USBHS		10.5	13.6	μA	VCC_USBHS = AVCC_USBHS (PHYSET.HSEB = 0)
		USBHS		4.4	6.0	mA	VCC_USBHS = AVCC_USBHS (PHYSET.HSEB = 1)
	Full speed	USBFS	I _{CCUSBFS}	4.0	10.0	mA	VCC_USB
		USBHS		11.4	13.7	mA	VCC_USBHS = AVCC_USBHS (PHYSET.HSEB = 0)
		USBHS		5.2	6.0	mA	VCC_USBHS = AVCC_USBHS (PHYSET.HSEB = 1)
	High speed	USBHS	I _{CCUSBHS}	45.7	51.4	mA	VCC_USBHS = AVCC_USBHS
	Standby mode (direct power down)	USBHS	I _{CCUSB_SB_Y}	0.5	3.00	μA	VCC_USBHS = AVCC_USBHS

Table 2.23 Operating current (Analog) (2 of 2)

Parameter		Symbol	Typ	Max 125 °C	Unit	Test conditions	
Supply current *1	MIPI operating current	DSI_ULP1	I _{CC18MPI}	1.5	2.5	mA	2 lanes PLL = OFF
		DSI_ULP2		1.5	2.5	mA	2 lanes PLL = ON
		DSI-LP		5.6	11.3	mA	2 lanes CL = 60pF
		DSI-HS		9.8	15.1	mA	2 lanes
		Standby		0.001	0.2	mA	Software standby mode, Deep Software standby mode
				1.0	3.1	mA	DPHYPWRCR.PWRS EN = 1'b0 in Normal mode, CPU Sleep mode or CPU Deep Sleep mode
				0.001	0.2	mA	DPHYPWRCR.PWRS EN = 1'b1 in Normal mode, CPU Sleep mode or CPU Deep Sleep mode
		DSI_ULP1	I _{CCMIPI}	1.4	6.5	mA	2 lanes PLL = OFF
		DSI_ULP2		4.0	10.1	mA	2 lanes PLL = ON
		DSI-LP		4.0	10.1	mA	2 lanes
		DSI-HS		9.0	24.2	mA	2 lanes
		Standby		0.001	0.1	mA	Software standby mode, Deep Software standby mode
				0.001	0.1	mA	DPHYPWRCR.PWRS EN = 1'b0 in Normal mode, CPU Sleep mode or CPU Deep Sleep mode
				1.0	2.0	mA	DPHYPWRCR.PWRS EN = 1'b1 in Normal mode, CPU Sleep mode or CPU Deep Sleep mode

Note 1. Supply current values are with all output pins unloaded and all input pull-up MOSs in the off state.

Note 2. When the MCU is in Software Standby mode or the MSTPCRD.MSTPD16 (12-Bit A/D Converter 0 Module Stop bit) and MSTPCRD.MSTPD15 (12-bit A/D converter 1 module stop bit) are in the module-stop state.

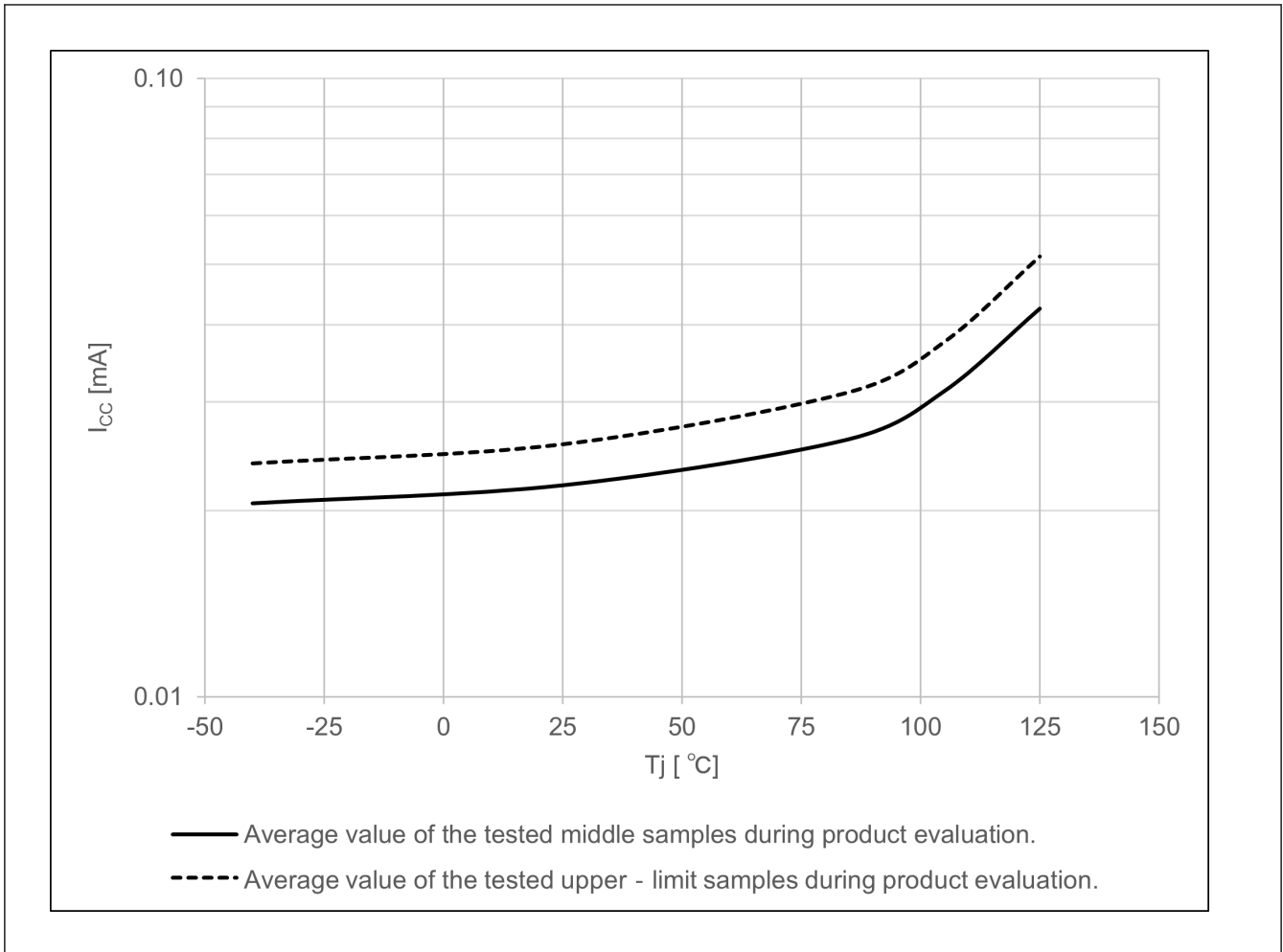

Figure 2.3 Temperature dependency in Software Standby mode (I_{CC}) (reference data)

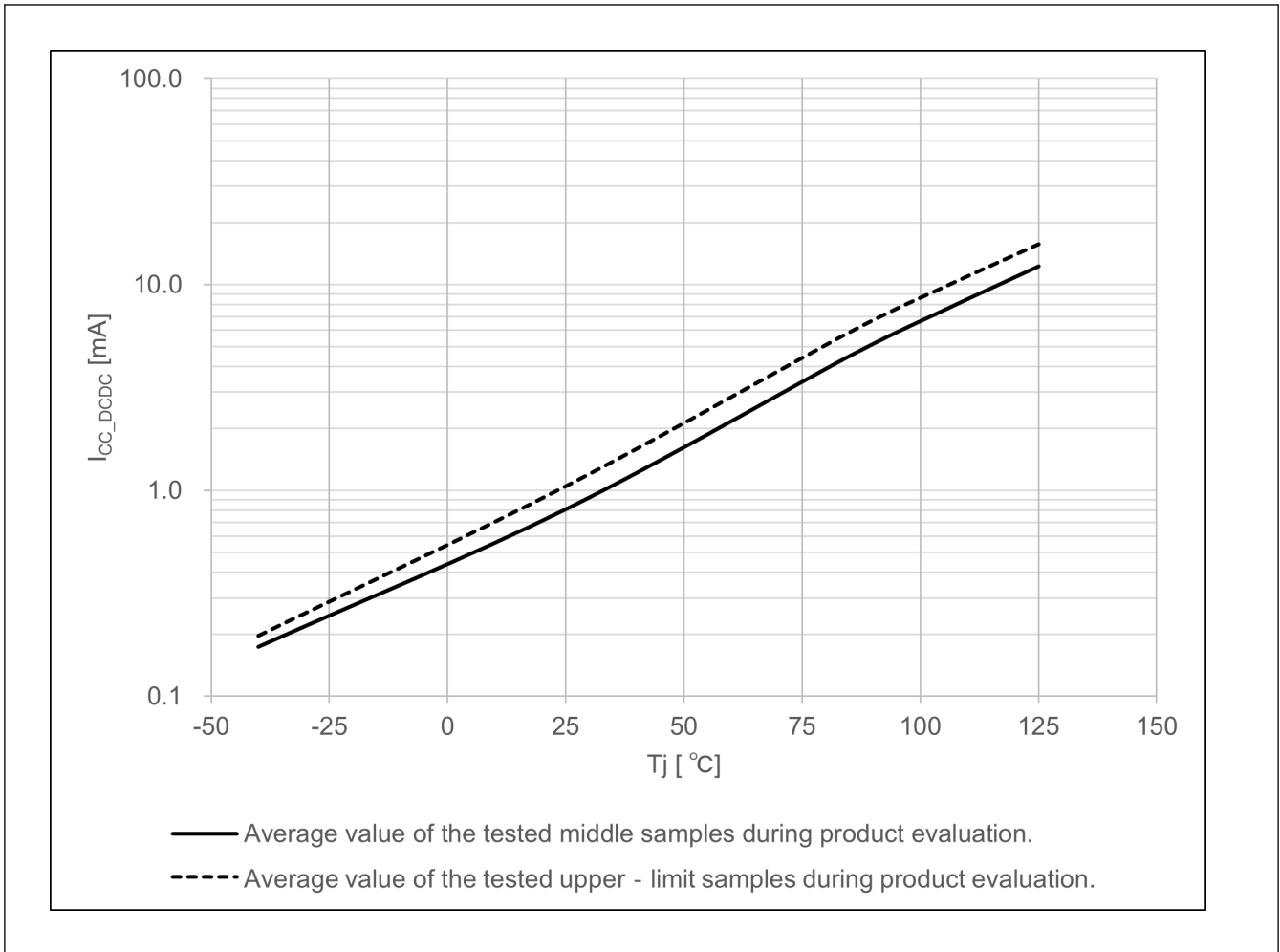

Figure 2.4 Temperature dependency in Software Standby mode (I_{CC_DCDC}) (reference data)

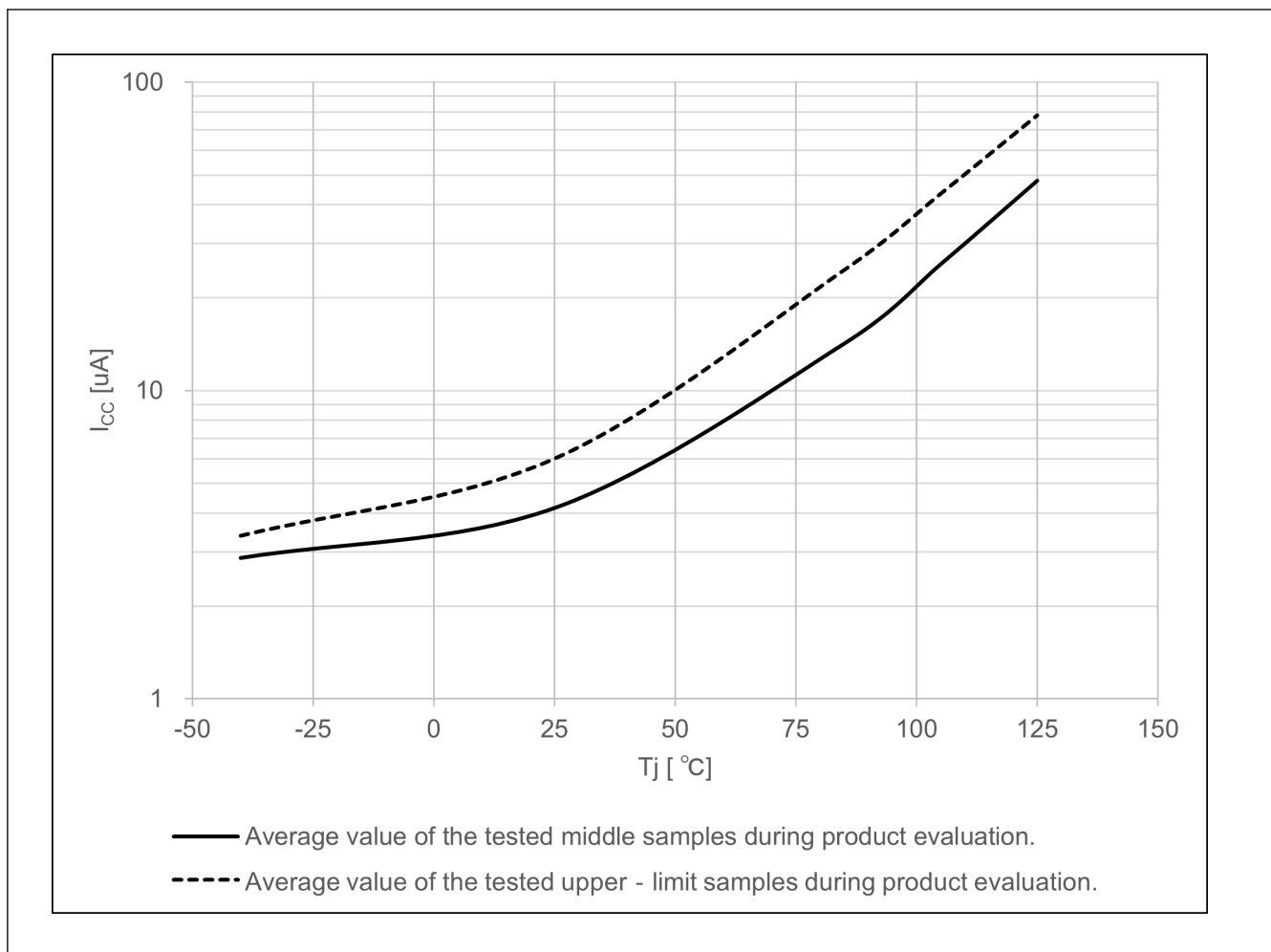

Figure 2.5 Temperature dependency in Deep Software Standby mode 1 (reference data)

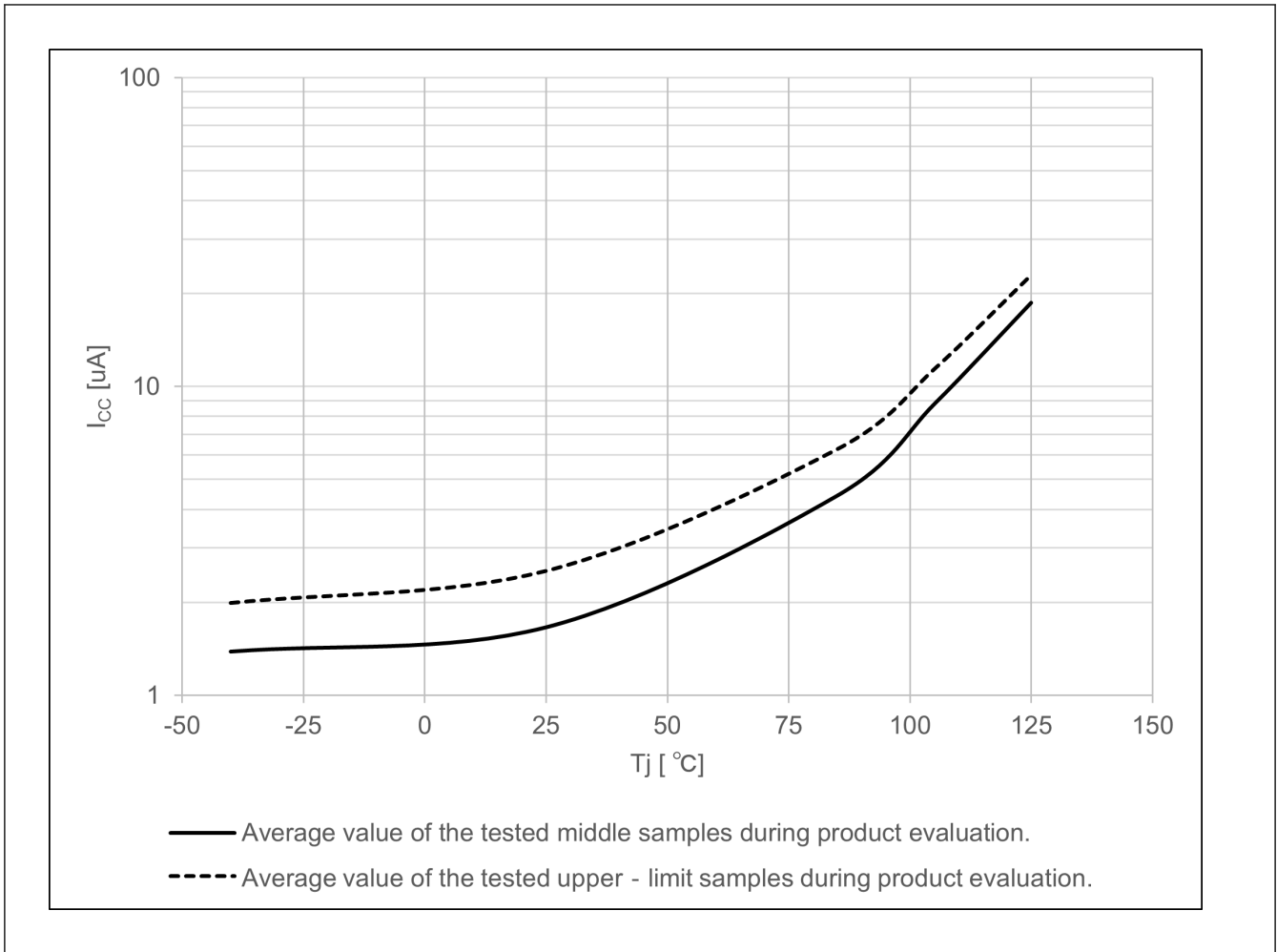

Figure 2.6 Temperature dependency in Deep Software Standby mode 2 (reference data)

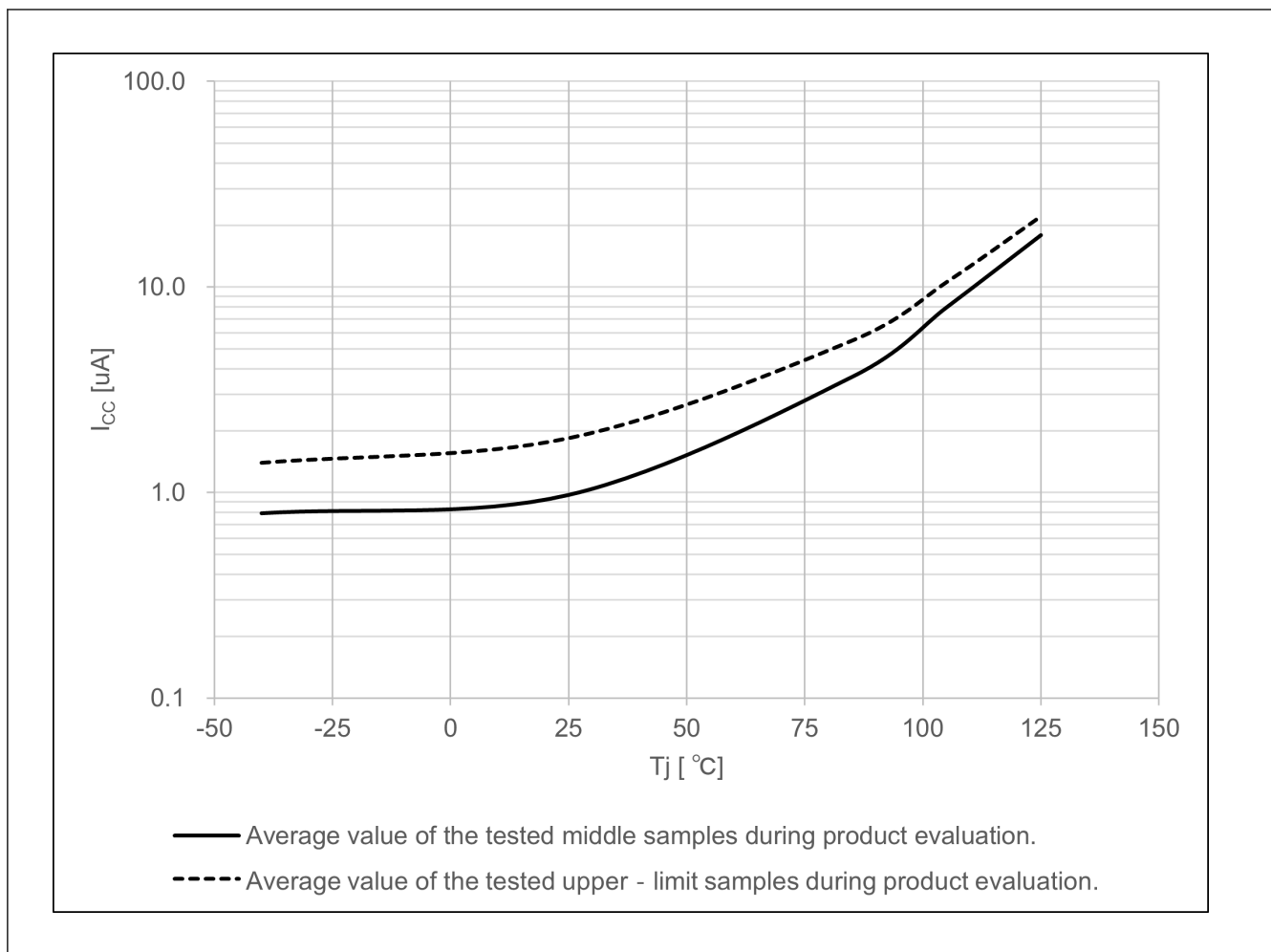

Figure 2.7 Temperature dependency in Deep Software Standby mode 3 (reference data)

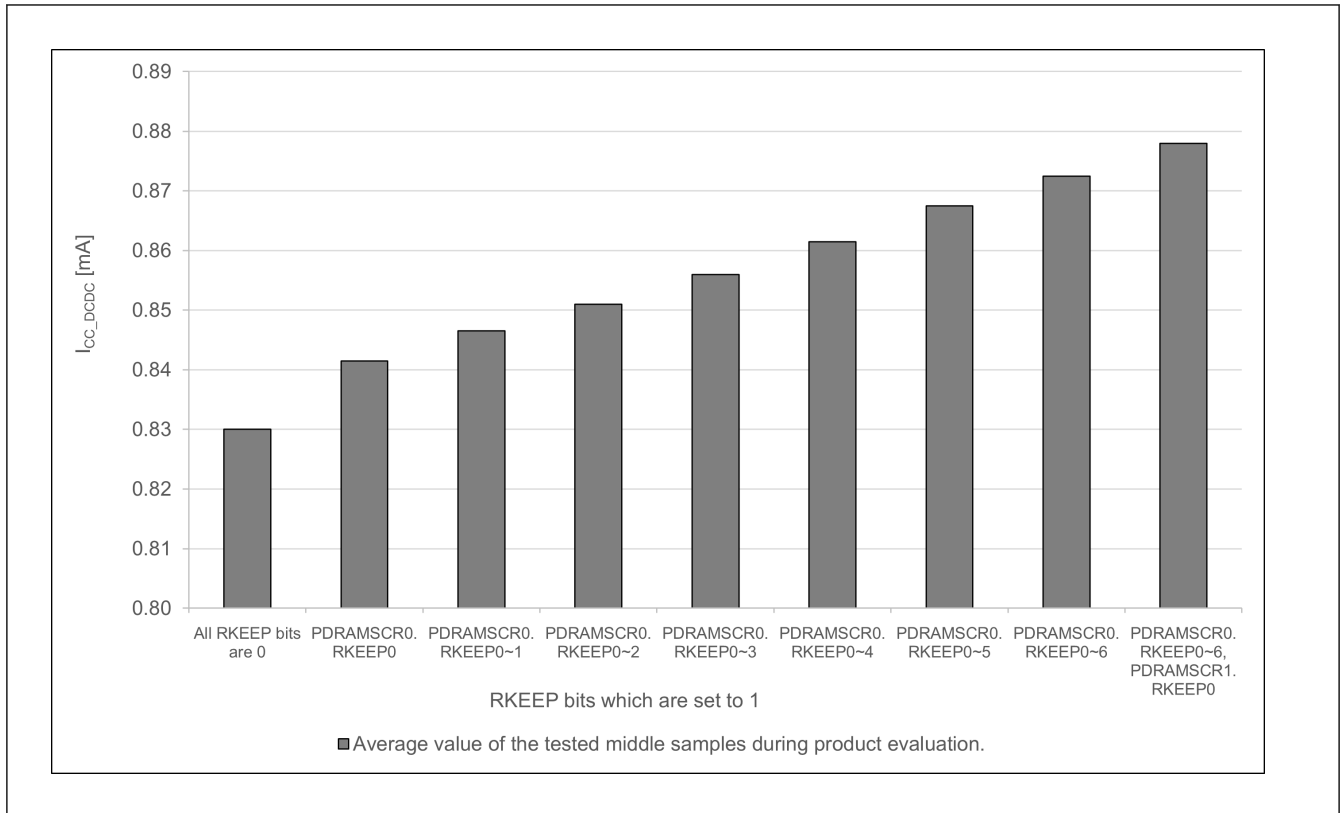

Figure 2.8 Software Standby current per SRAM state (reference data)

The more practical I_{CC_DCDC} value can be obtained with the following formula.

$$I_{CC_DCDC} = I_{DD} \times (V_{CL} \div V_{CC}) \div \text{efficiency}$$

Where: V_{CL} and V_{CC} are the voltage of V_{CL} pin and V_{CC} pin respectively, and efficiency is shown in the following figures.

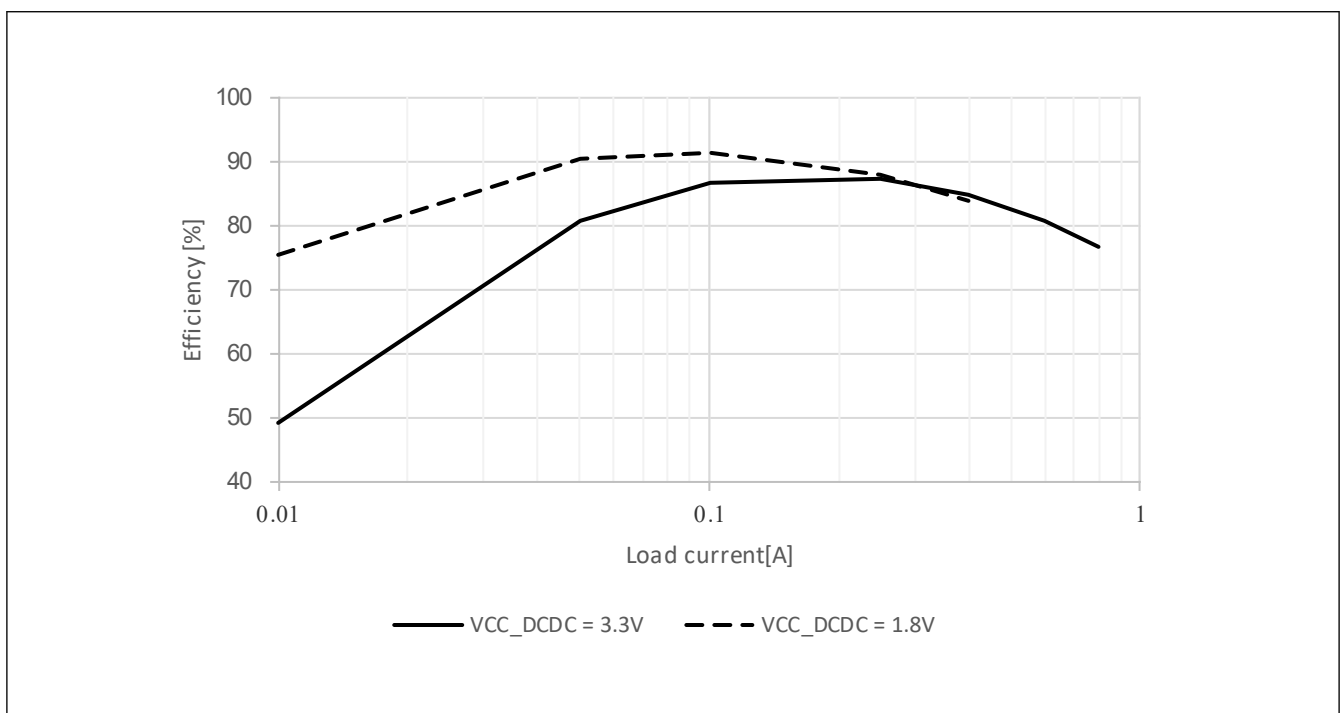

Figure 2.9 Typical DCDC efficiency (%) vs load current (A) in High-speed mode , Tj = 25°C

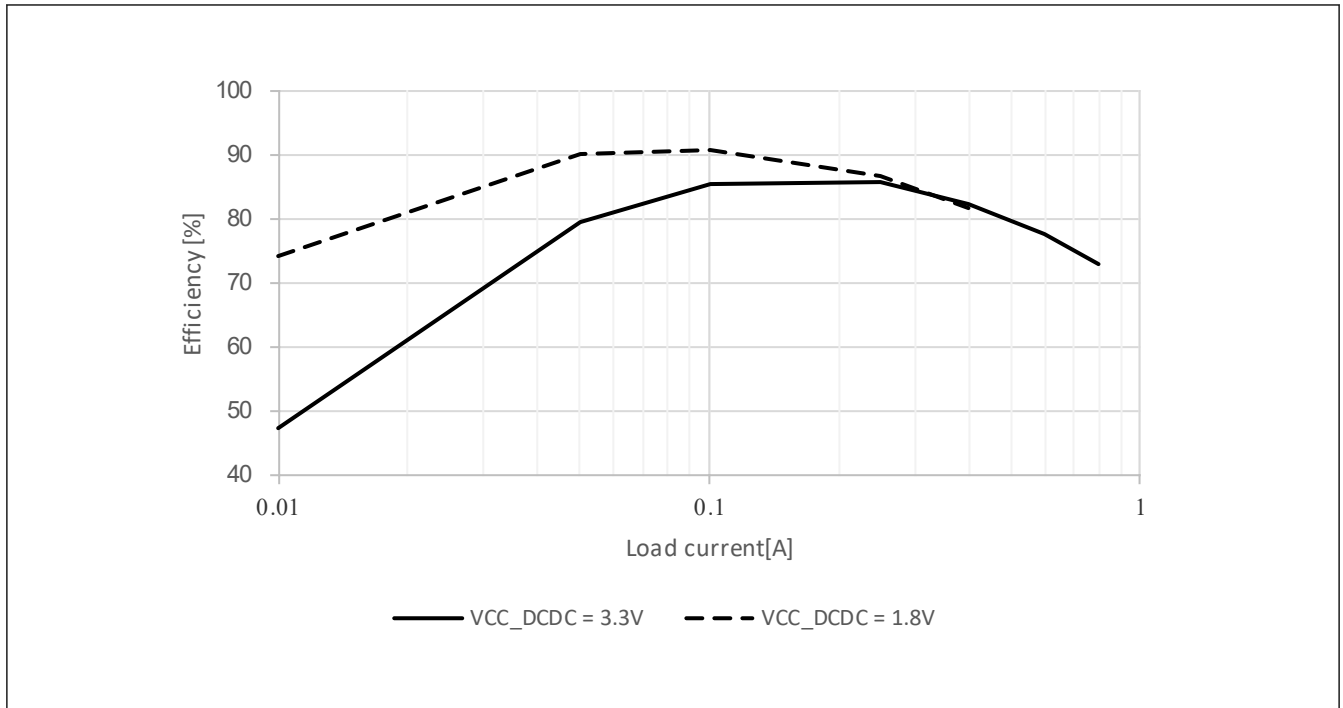

Figure 2.10 Typical DCDC efficiency (%) vs load current (A) in High-speed mode , Tj = 125°C

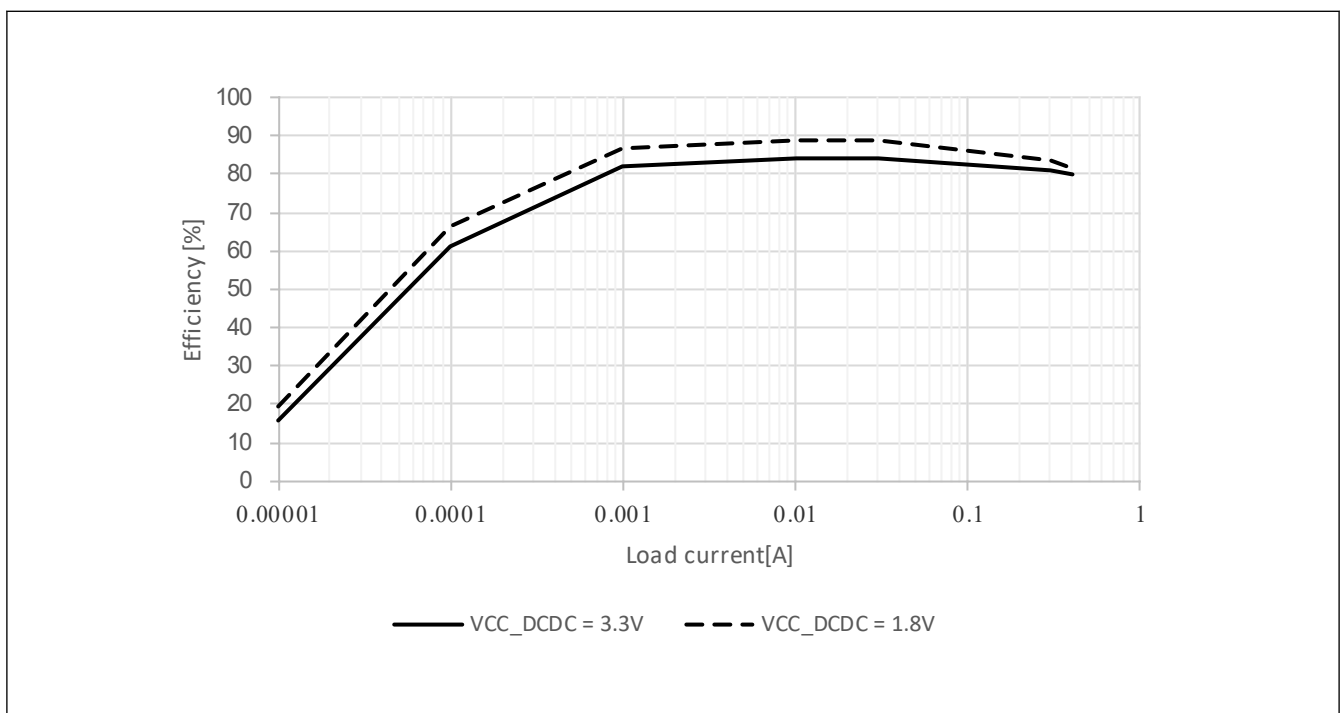

Figure 2.11 Typical DCDC efficiency (%) vs load current (A) in Low-speed mode and Software Standby mode, Tj = 25°C

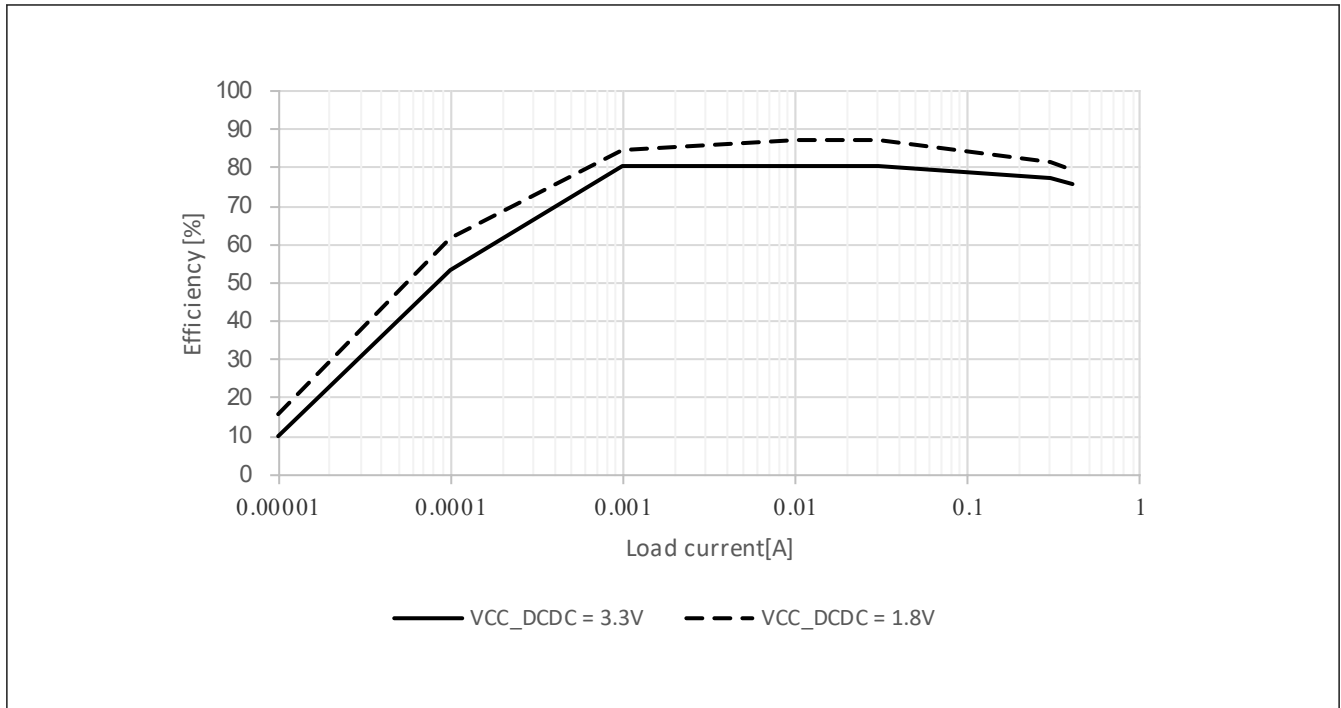

Figure 2.12 Typical DCDC efficiency (%) vs load current (A) in Low-speed mode and Software Standby mode, $T_j = 125^\circ\text{C}$

Note: DCDC efficiency is obtained based on the VCC_DCDC current.

2.2.6 VCC Rise and Fall Gradient and Ripple Frequency

Table 2.24 VCC rise and fall gradient characteristics at power on/off

Parameter	Symbol	Min	Typ	Max	Unit	Test conditions
VCC rising gradient at power on*1	SrVCC	0.0084	—	20	ms/V	—
VCC falling gradient at power off	VBATT function is disabled*1	SfVCC1	0.0084	—	—	ms/V
	VBATT function is enabled	SfVCC2	1.0000	—	—	—

Note 1. In case the VCC voltage crosses V_{POR1} .

Table 2.25 VCC ripple frequency and gradient characteristics during operation

The ripple voltage must meet the allowable ripple frequency $f_r(VCC)$ within the range between the VCC upper limit (3.6 V) and lower limit (1.68 V). When the VCC change exceeds $VCC \pm 10\%$, the allowable voltage change rising and falling gradient $dt/dVCC$ must be met.

Parameter	Symbol	Min	Typ	Max	Unit	Test conditions
Allowable ripple frequency	$f_r(VCC)$	—	—	10.0	kHz	Figure 2.13 $V_r(VCC) \leq VCC \times 0.2$
		—	—	1.0	MHz	Figure 2.13 $V_r(VCC) \leq VCC \times 0.08$
		—	—	10.0	MHz	Figure 2.13 $V_r(VCC) \leq VCC \times 0.06$
Allowable voltage change rising and falling gradient	$dt/dVCC^{*1}$	1.0	—	—	ms/V	When VCC change exceeds $VCC \pm 10\%$

Note 1. In case the VCC voltage does not cross V_{POR1} .

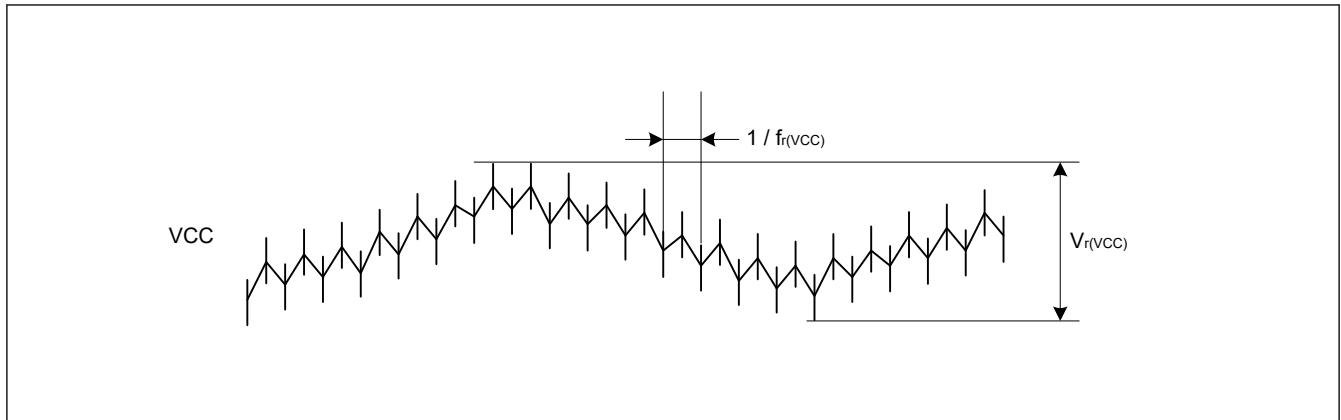

Figure 2.13 Ripple waveform

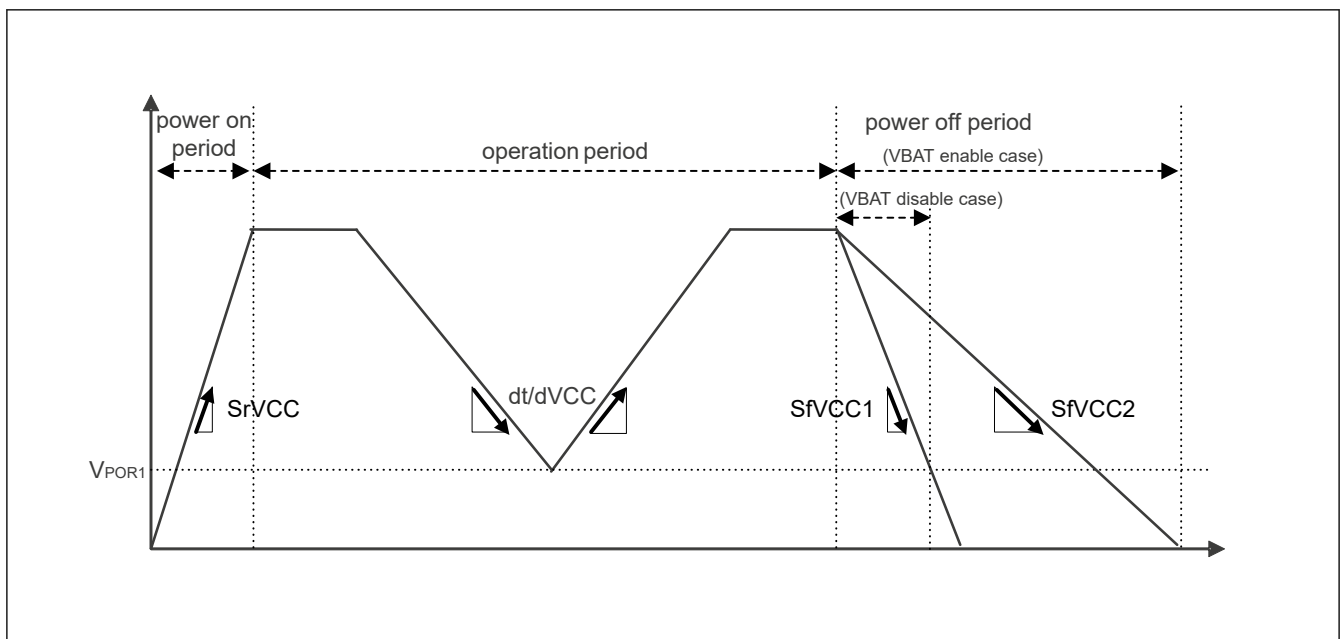

Figure 2.14 VCC rising and falling waveform

2.2.7 Thermal Characteristics

Maximum value of junction temperature (T_j) must not exceed the value of [section 2.2.1. \$T_j/T_a\$ Definition](#).

T_j is calculated by either of the following equations.

- $T_j = T_a + \theta_{ja} \times \text{Total power consumption}$
- $T_j = T_t + \Psi_{jt} \times \text{Total power consumption}$
 - T_j : Junction Temperature ($^{\circ}\text{C}$)
 - T_a : Ambient Temperature ($^{\circ}\text{C}$)
 - T_t : Top Center Case Temperature ($^{\circ}\text{C}$)
 - θ_{ja} : Thermal Resistance of “Junction”-to-“Ambient” ($^{\circ}\text{C}/\text{W}$)
 - Ψ_{jt} : Thermal Resistance of “Junction”-to-“Top Center Case” ($^{\circ}\text{C}/\text{W}$)
- Total power consumption = Voltage \times (Leakage current + Dynamic current)
- Leakage current of IO = $\Sigma (I_{OL} \times V_{OL}) / \text{Voltage} + \Sigma (|I_{OH}| \times |VCC - V_{OH}|) / \text{Voltage}$
- Dynamic current of IO = $\Sigma IO (C_{in} + C_{load}) \times IO \text{ switching frequency} \times \text{Voltage}$
 - C_{in} : Input capacitance
 - C_{load} : Output capacitance

Regarding θ_{ja} and Ψ_{jt} , see [Table 2.26](#).

Table 2.26 Thermal Resistance

Parameter	Package	Symbol	Value*1	Unit	Test conditions
Thermal Resistance	176-pin LQFP (PLQP0176KJ-A)	θ_{ja}	32.0	°C/W	JESD 51-2 and 51-7 compliant
	224-pin BGA (PLBG0224GD-A)		21.5		JESD 51-2 and 51-9 compliant
	176-pin LQFP (PLQP0176KJ-A)	Ψ_{jt}	0.42	°C/W	JESD 51-2 and 51-7 compliant
	224-pin BGA (PLBG0224GD-A)		0.24		JESD 51-2 and 51-9 compliant

Note 1. The values are reference values when the 4-layer board is used. Thermal resistance depends on the number of layers or size of the board. For details, see the JEDEC standards.

2.2.7.1 Calculation guide of maximum current

Table 2.27 Power consumption of each unit (1 of 2)

Dynamic current/ Leakage current	MCU Domain	Category	Item	Symbol	Frequency [MHz]	Current [uA/MHz]	Current*1 [mA]	Condition		
Leakage current	Analog	Regulator and Leak*1	Tj = 95°C	I_{CC}	—	—	0.54	—		
			Tj = 105°C		—	—	0.64			
			Tj = 115°C		—	—	0.75			
			Tj = 125°C		—	—	0.85			
			Tj = 95°C	I_{CC_DCDC}	VCC_DCDC = 3.3V, High speed mode, PDCTRGD.P DDE = 0	—	—	64	—	
			Tj = 105°C			—	—	77		
			Tj = 115°C			—	—	94		
			Tj = 125°C			—	—	111		
			Tj = 95°C	VCC_DCDC = 1.8V, High speed mode, PDCTRGD.P DDE = 0		—	—	115	—	
			Tj = 105°C			—	—	138		
			Tj = 115°C			—	—	168		
			Tj = 125°C			—	—	199		
			Tj = 95°C	I_{DD}		PDCTRGD.P DDE = 0	—	—	150	—
			Tj = 105°C				—	—	180	
Tj = 115°C	—	—	220							
Tj = 125°C	—	—	260							
Dynamic current	CPU	Operation with Cache	CoreMark	I_{DD}	480		307	147	CPUCLK = 480MHz	
			Peripheral Unit		Timer		RTC	60		1.299
	GPT16 (6ch)*2	120					16.988	2.039		
	GPT32 (8ch)*2	120					20.279	2.433		
	POEG (4 Groups)*2	60					1.363	0.082		
	AGT (2ch)*2	60					2.233	0.134		
	ULPT (2ch)*2	60					0.350	0.021		
	WDT	60					0.775	0.047		
	IWDT	60					0.100	0.006		

Table 2.27 Power consumption of each unit (2 of 2)

Dynamic current/ Leakage current	MCU Domain	Category	Item	Symbol	Frequency [MHz]	Current [uA/MHz]	Current*1 [mA]	Condition		
Dynamic current	Peripheral Unit	Communication interfaces	ETHERC	I _{DD}	120	8.149	0.978	—		
			USBFS		60	8.713	0.523			
			USBHS		120	11.911	1.429			
			SCI (6ch)*2		120	22.717	2.726			
			IIC (2ch)*2		60	2.867	0.172			
			I3C		120	15.274	1.833			
			CANFD (2ch)*2		120	9.050	1.086			
			SPI (2ch)*2		120	7.950	0.954			
			OSPI		60	40.796	2.448			
			SSIE (2ch)*2		60	6.818	0.409			
			SDHI (2ch)*2		60	16.742	1.005			
			Analog		ADC (2Units)*2	120	3.961		0.475	—
		DAC12 (2ch)*2		120	1.079	0.129				
		TSN		60	0.092	0.005				
		ACMPHS (2ch)*2		60	0.083	0.005				
		Human machine interfaces	GLCDC	120	44.530	5.344	—			
			DRW	120	59.158	7.099				
			MIPI DSI	120	31.344	3.761				
			CEU	120	24.143	2.897				
		Event link	ELC	60	1.670	0.100	—			
		Security	RSIP-E51A	120	311.301	37.4	—			
			DOTF	60	63.393	3.804				
		Data processing	CRC	120	4.372	0.525	—			
			DOC	120	0.427	0.051				
		System	CAC	60	0.738	0.044	—			
		DMA	DMAC (per 1ch)	240	9.012	2.163	—			
			DTC	240	8.980	2.155				
		FSBL operation					240	—	93.4	—
							120	—	72.9	—

Note 1. Regulator and Leak are Internal voltage regulator's current and MCU's leakage current.
It is selected according to the temperature of T_j.

Note 2. To determine the current consumption per channel or unit, divide Current [mA] by the number of channels, groups or units.

Table 2.28 Outline of operation for each unit (1 of 2)

Peripheral	Outline of operation
RTC	RTC is operating with LOCO.
GPT	Operating modes is set to saw-wave PWM mode.
POEG	Only clear module stop bit.
AGT	AGT is operating with PCLKB.
ULPT	ULPT is operating with LOCO.

Table 2.28 Outline of operation for each unit (2 of 2)

Peripheral	Outline of operation
WDT	WDT is operating with PCLKB.
IWDT	IWDT is operating with IWDTCLK.
ETHERC	Operation modes is set to full-duplex mode. ETHERC is operating using Reduced Media Independent Interface (RMII).
USBFS	Transfer types is set to bulk transfer. USBFS is operating using Full-speed transfer (12 Mbps).
USBHS	Transfer types is set to bulk transfer. USBHS is operating using High-speed transfer.
SCI	SCI is transmitting data in clock synchronous mode.
IIC	Communication format is set to I2C-bus format. IIC is transmitting data in master mode.
I3C	Communication format is set to I3C SDR format. I3C is transmitting data in master mode (12.5MHz).
CANFD	CANFD is transmitting and receiving data in self-test mode 1.
SPI	SPI mode is set to SPI operation (4-wire method). SPI master/slave mode is set to master mode. SPI is transmitting 32-bit width data.
OSPI	OSPI is issuing memory write command to HyperRAM.
SSIE	Communication mode is set to Master. System word length is set to 32 bits. Data word length is set to 20 bits. SSIE is transmitting data using I2S format.
SDHI	Transfer bus mode is set to 8-bit wide bus mode. SDHI is issuing CMD24 (single-block write).
ADC	Resolution is set to 12-bit accuracy. Data registers is set to A/D-converted value addition mode. ADC12 is converting the analog input in continuous scan mode.
DAC12	DAC12 is outputting the conversion result while updating the value of data register.
TSN	TSN is operating.
ACMPHS	ACMPHS is operating.
GLCDC	GLCDC is operating after writing data to CLUT.
DRW	DRW is doing rendering operation after sending data from SDRAM.
MIPI DSI	MIPI DSI is operating with HS mode using 2-lane. Data is input via GLCDC.
CEU	CEU is capturing data and transferring to the SRAM.
ELC	Only clear module stop bit.
RSIP-E51A	RSIP is doing self-test operation.
DOTF	DOTF is doing decryption with AES.
CRC	CRC is generating CRC code using 32-bit CRC32-C polynomial.
DOC	DOC is operating in data comparison mode.
CAC	Measurement target clocks is set to PCLKB. Measurement reference clocks is set to PCLKB. CAC is measuring the clock frequency accuracy.
DMAC	Bit length of transfer data is set to 32 bits. Transfer mode is set to block transfer mode. DMAC is transferring data from SRAM0 to SRAM0.
DTC	Bit length of transfer data is set to 32 bits. Transfer mode is set to block transfer mode. DTC is transferring data from SRAM0 to SRAM0.

2.2.7.2 Example of Tj calculation

Assumption :

- Package 224-pin BGA : $\theta_{ja} = 21.5 \text{ }^{\circ}\text{C/W}$
- $T_a = 80 \text{ }^{\circ}\text{C}$
- $I_{CC} + I_{CC_DCDC} = 240 \text{ mA}$
- $V_{CC} = 3.5 \text{ V}$ ($V_{CC} = V_{CC2} = AV_{CC0} = AV_{CC_USBHS} = V_{CC_USB} = V_{CC_USBHS}$)
- $I_{OH} = 1 \text{ mA}$, $V_{OH} = V_{CC} - 0.5 \text{ V}$, 12 Outputs

- $I_{OL} = 20 \text{ mA}$, $V_{OL} = 1.0 \text{ V}$, 8 Outputs
- $I_{OL} = 1 \text{ mA}$, $V_{OL} = 0.5 \text{ V}$, 12 Outputs
- $C_{in} = 8 \text{ pF}$, 32 pins, Input frequency = 10 MHz
- $C_{load} = 30 \text{ pF}$, 32 pins, Output frequency = 10 MHz

$$\begin{aligned} \text{Static current of IO} &= \Sigma (V_{OL} \times I_{OL}) / \text{Voltage} + \Sigma ((V_{CC} - V_{OH}) \times I_{OH}) / \text{Voltage} \\ &= (20 \text{ mA} \times 1 \text{ V}) \times 8 / 3.5 \text{ V} + (1 \text{ mA} \times 0.5 \text{ V}) \times 12 / 3.5 \text{ V} + ((V_{CC} - (V_{CC} - 0.5 \text{ V})) \times 1 \text{ mA}) \times 12 / 3.5 \text{ V} \\ &= 45.7 \text{ mA} + 1.71 \text{ mA} + 1.71 \text{ mA} \\ &= 49.1 \text{ mA} \end{aligned}$$

$$\begin{aligned} \text{Dynamic current of IO} &= \Sigma IO (C_{in} + C_{load}) \times \text{IO switching frequency} \times \text{Voltage} \\ &= ((8 \text{ pF} \times 32) \times 10 \text{ MHz} + (30 \text{ pF} \times 32) \times 10 \text{ MHz}) \times 3.5 \text{ V} \\ &= 42.6 \text{ mA} \end{aligned}$$

$$\begin{aligned} \text{Total power consumption} &= \text{Voltage} \times (\text{Static current} + \text{Dynamic current}) \\ &= (240 \text{ mA} \times 3.5 \text{ V}) + (49.1 \text{ mA} + 42.6 \text{ mA}) \times 3.5 \text{ V} \\ &= 1161 \text{ mW (1.161 W)} \end{aligned}$$

$$\begin{aligned} T_j &= T_a + \theta_{ja} \times \text{Total power consumption} \\ &= 80 \text{ }^\circ\text{C} + 21.5 \text{ }^\circ\text{C/W} \times 1.161 \text{ W} \\ &= 105.0 \text{ }^\circ\text{C} \end{aligned}$$

2.3 AC Characteristics

2.3.1 Frequency

Table 2.29 Operation frequency value in high-speed mode

Parameter			Symbol	Min	Typ	Max	Unit
Operation frequency	CPU clock (CPUCLK)	DCDC, BGA package, $T_j \leq 105^\circ\text{C}^{*3}$	f	—	—	480	MHz
		DCDC, BGA package, $T_j \leq 125^\circ\text{C}^{*3}$		—	—	400	
		External VDD, BGA package, $T_j \leq 105^\circ\text{C}$		—	—	480	
		External VDD, BGA package, $T_j \leq 125^\circ\text{C}$		—	—	400	
		DCDC, 176-pin LQFP package, $T_j \leq 125^\circ\text{C}^{*3}$		—	—	400	
		External VDD, 176-pin LQFP package, $T_j \leq 125^\circ\text{C}$		—	—	400	
	System clock (ICLK)			—	—	240	
	Peripheral module clock (PCLKA)			—	—	120	
	Peripheral module clock (PCLKB)			—	—	60	
	Peripheral module clock (PCLKC)			— ^{*2}	—	60	
	Peripheral module clock (PCLKD)			—	—	120	
	Peripheral module clock (PCLKE)			—	—	240	
	Flash interface clock (FCLK)			— ^{*1}	—	60	
	External bus clock (BCLK)	$V_{CC} \geq 2.7\text{ V}$		—	—	120	
		$V_{CC} \geq 1.68\text{ V}$		—	—	60	
	EBCLK pin output	$V_{CC} \geq 2.7\text{ V}$		—	—	60	
		$V_{CC} \geq 1.68\text{ V}$		—	—	30	
	SDCLK pin output	$V_{CC} \geq 3.0\text{ V}$		—	—	120	
	SCI clock (SCICLK)			—	—	120	
	SPI clock (SPICLK)			—	—	120	
Octal SPI clock (OCTACLK)		—	—	200			
CANFD core clock (CANFDCLK)		—	—	80			
LCD clock (LCDCLK)		—	—	240			
USB clock (USBCLK)		—	—	48			
USB clock (USB60CLK)		—	—	60			
I3C clock (I3CCLK)		—	—	200			

Note 1. FCLK must run at a frequency of at least 4 MHz when programming or erasing the flash memory.

Note 2. When the ADC12 is used, the PCLKC frequency must be at least 1 MHz.

Note 3. When DCDC is used with $V_{CC_DCDC} < 2.5\text{V}$, I_{DD} current must be less than the value specified in operating current.

Please see [Table 2.8](#).

Table 2.30 Operation frequency value in low-speed mode

Parameter		Symbol	Min	Typ	Max	Unit	
Operation frequency	CPU clock (CPUCLK)	f	—	—	1	MHz	
	System clock (ICLK)		—	—	1		
	Peripheral module clock (PCLKA)		—	—	1		
	Peripheral module clock (PCLKB)		—	—	1		
	Peripheral module clock (PCLKC)		—*2	—	1		
	Peripheral module clock (PCLKD)		—	—	1		
	Peripheral module clock (PCLKE)		—	—	1		
	Flash interface clock (FCLK)		—*1	—	1		
	External bus clock (BCLK)		—	—	1		
	EBCLK pin output		—	—	1		
	SDCLK pin output		VCC ≥ 3.0 V	—	—		1
	SCI clock (SCICLK)		—	—	1		
	SPI clock (SPICLK)		—	—	1		
	Octal SPI clock (OCTACLK)		—	—	1		
	CANFD core clock (CANFDCLK)		—	—	1		
	LCD clock (LCDCLK)		—	—	1		
	USB clock (USBCLK)		—	—	1		
USB clock (USB60CLK)	—	—	1				
I3C clock (I3CCLK)	—	—	1				

Note 1. Programming or erasing the flash memory is disabled in low-speed mode.

Note 2. When the ADC12 is used, the PCLKC frequency must be at least 1 MHz.

2.3.2 Clock Timing

Table 2.31 Clock timing except for sub-clock oscillator (1 of 2)

Parameter		Symbol	Min	Typ	Max	Unit	Test conditions
EBCLK pin output cycle time	VCC = 2.70 V or above	t _{Bcyc}	16.6	—	—	ns	Figure 2.15
	VCC = 1.68 V or above		33.3	—	—		
EBCLK pin output high pulse width	VCC = 2.70 V or above	t _{CH}	3.3	—	—	ns	
	VCC = 1.68 V or above		9.6	—	—		
EBCLK pin output low pulse width	VCC = 2.70 V or above	t _{CL}	3.3	—	—	ns	
	VCC = 1.68 V or above		9.6	—	—		
EBCLK pin output rise time	VCC = 2.70 V or above	t _{Cr}	—	—	5.0	ns	
	VCC = 1.68 V or above		—	—	7.0		
EBCLK pin output fall time	VCC = 2.70 V or above	t _{Cf}	—	—	5.0	ns	
	VCC = 1.68 V or above		—	—	7.0		
SDCLK pin output cycle time		t _{SDcyc}	8.33	—	—	ns	
SDCLK pin output high pulse width		t _{CH}	1.0	—	—	ns	
SDCLK pin output low pulse width		t _{CL}	1.0	—	—	ns	
SDCLK pin output rise time		t _{Cr}	—	—	3.0	ns	
SDCLK pin output fall time		t _{Cf}	—	—	3.0	ns	

Table 2.31 Clock timing except for sub-clock oscillator (2 of 2)

Parameter	Symbol	Min	Typ	Max	Unit	Test conditions		
EXTAL external clock input cycle time	t_{EXcyc}	20.80	—	—	ns	Figure 2.16		
EXTAL external clock input high pulse width	t_{EXH}	5.30	—	—	ns			
EXTAL external clock input low pulse width	t_{EXL}	5.30	—	—	ns			
EXTAL external clock rise time	t_{EXr}	—	—	3.0	ns			
EXTAL external clock fall time	t_{EXf}	—	—	3.0	ns			
Main clock oscillator frequency	f_{MAIN}	8	—	48	MHz	—		
Main clock oscillation stabilization wait time (crystal)*1	$t_{MAINOSCW T}$	—	—	—*1	ms	Figure 2.17		
LOCO clock oscillation frequency	f_{LOCO}	29.4912	32.768	36.0448	kHz	—		
LOCO clock oscillation stabilization wait time	t_{LOCOWT}	—	—	60.4	μ s	Figure 2.18		
MOCO clock oscillation frequency	f_{MOCO}	6.8	8.0	9.2	MHz	—		
MOCO clock oscillation stabilization wait time	t_{MOCOWT}	—	—	15.0	μ s	—		
HOCO clock oscillator oscillation frequency	Without FLL	f_{HOCO16}	15.78	16.00	16.22	MHz	$-20 \leq T_j \leq 125 \text{ }^\circ\text{C}$	
		f_{HOCO18}	17.75	18.00	18.25			
		f_{HOCO20}	19.72	20.00	20.28			
		f_{HOCO32}	31.55	32.00	32.45			
		f_{HOCO48}	47.33	48.00	48.67			
	$-40 \leq T_j \leq -20 \text{ }^\circ\text{C}$	f_{HOCO16}	15.71	16.00	16.29			
		f_{HOCO18}	17.68	18.00	18.32			
		f_{HOCO20}	19.64	20.00	20.36			
		f_{HOCO32}	31.42	32.00	32.58			
		f_{HOCO48}	47.14	48.00	48.86			
	With FLL	f_{HOCO16}	15.960	16.000	16.040	MHz	$-40 \leq T_j \leq 125 \text{ }^\circ\text{C}$ Sub-clock frequency accuracy is ± 50 ppm.	
		f_{HOCO18}	17.955	18.000	18.045			
		f_{HOCO20}	19.950	20.000	20.050			
		f_{HOCO32}	31.920	32.000	32.080			
		f_{HOCO48}	47.880	48.000	48.120			
HOCO clock oscillation stabilization wait time*2	t_{HOCOWT}	—	—	64.7	μ s			—
HOCO stop width time	$t_{HOCOSTP}$	1	—	—	μ s			Figure 2.21
HOCO period jitter	Jitter	-3	—	3	%			—
FLL stabilization wait time	t_{FLLWT}	—	—	1.8	ms			—
PLL1/PLL2 VCO frequency	f_{VCO}	640	—	1440.0	MHz			—
PLL1/PLL2 Output frequency for output clock P	t_{PLL}	40	—	480	MHz	—		
PLL1/PLL2 Output frequency for output clock Q, R	t_{PLL}	71	—	480	MHz	—		
PLL1/PLL2 clock oscillation stabilization wait time	t_{PLLWT}	—	—	40	μ s	Figure 2.19		
PLL1/PLL2 period jitter	—	—	± 70	—	ps	—		
PLL1/PLL2 long term jitter	—	—	± 300	—	ps	Term: 1 μ s, 10 μ s		

Note 1. When setting up the main clock oscillator, ask the oscillator manufacturer for an oscillation evaluation, and use the results as the recommended oscillation stabilization time. Set the MOSCWTCR register to a value equal to or greater than the recommended value.

After changing the setting in the MOSCCR.MOSTP bit to start main clock operation, read the OSCSF.MOSCSF flag to confirm that it is 1, and then start using the main clock oscillator.

Note 2. This is the time from release from reset state until the HOCO oscillation frequency (f_{HOCO}) reaches the range for guaranteed operation.

Table 2.32 Clock timing for the sub-clock oscillator

Parameter	Symbol	Min	Typ	Max	Unit	Test conditions
Sub-clock frequency	f_{SUB}	—	32.768	—	kHz	—
Sub-clock oscillation stabilization wait time	$t_{SUBOSCWT}$	—	—	—*1	s	Figure 2.20

Note 1. When setting up the sub-clock oscillator, ask the oscillator manufacturer for an oscillation evaluation and use the results as the recommended oscillation stabilization time.
 After changing the setting in the SOSCCR.SOSTP bit to start sub-clock operation, only start using the sub-clock oscillator after the sub-clock oscillation stabilization time elapses with an adequate margin. A value that is two times the value shown is recommended.

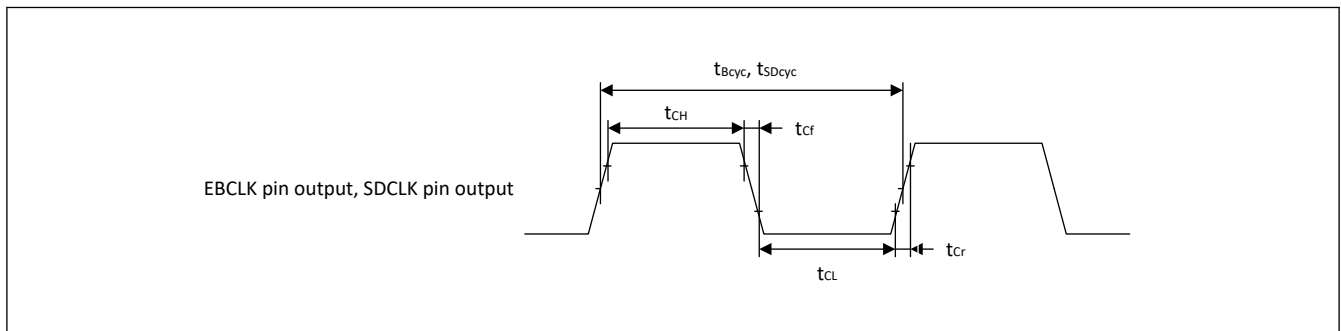

Figure 2.15 EBCLK and SDCLK output timing

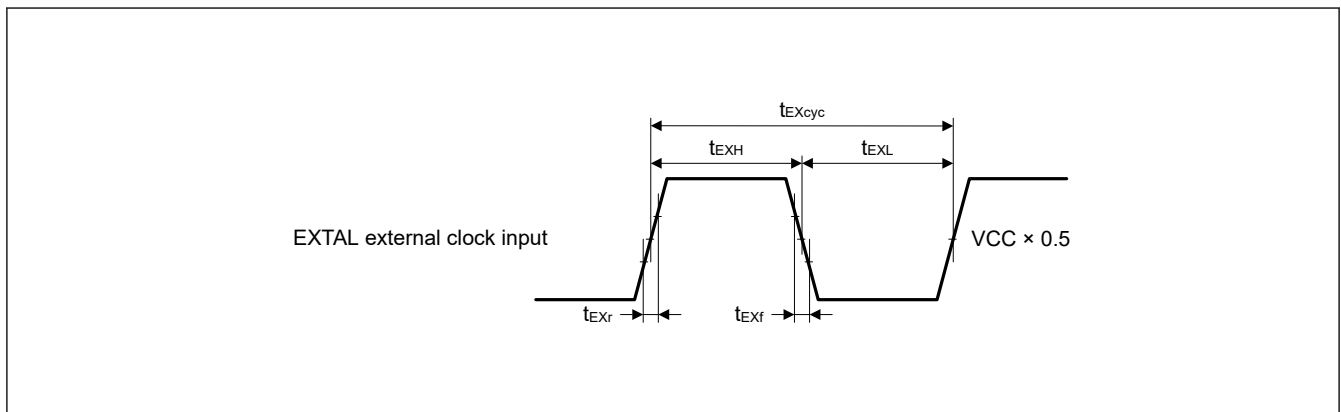

Figure 2.16 EXTAL external clock input timing

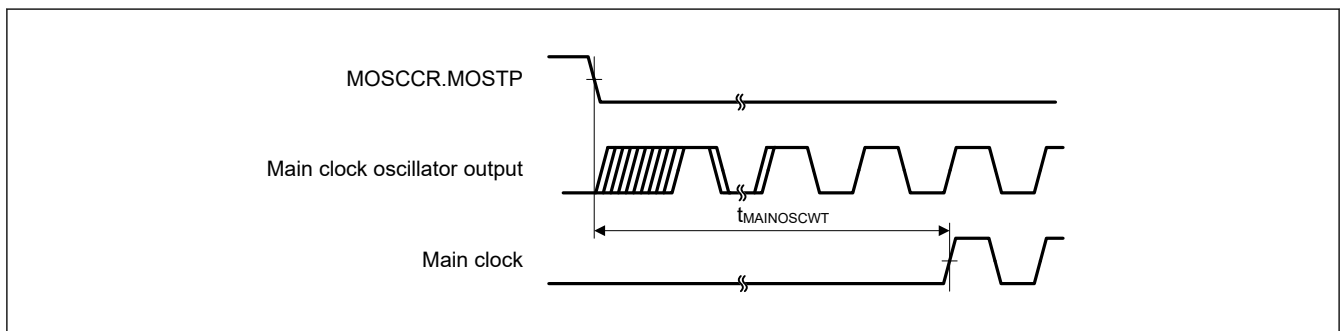

Figure 2.17 Main clock oscillation start timing

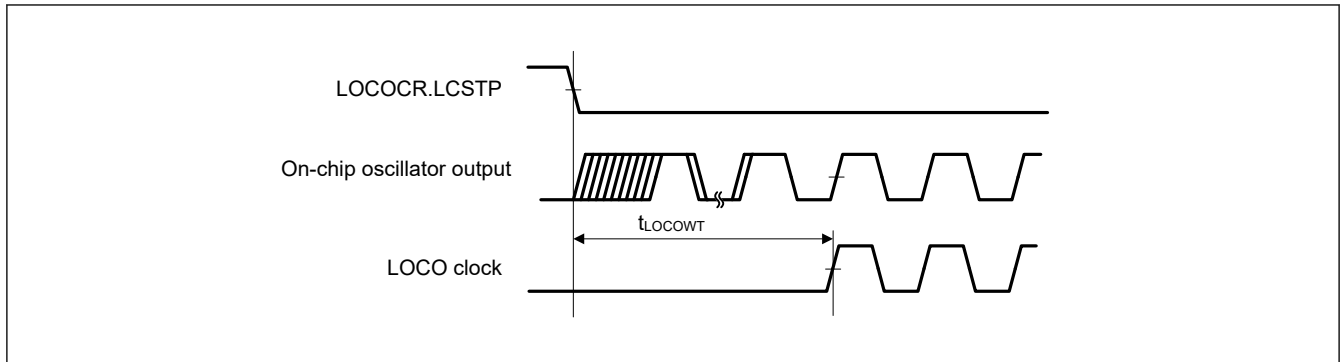

Figure 2.18 LOCO clock oscillation start timing

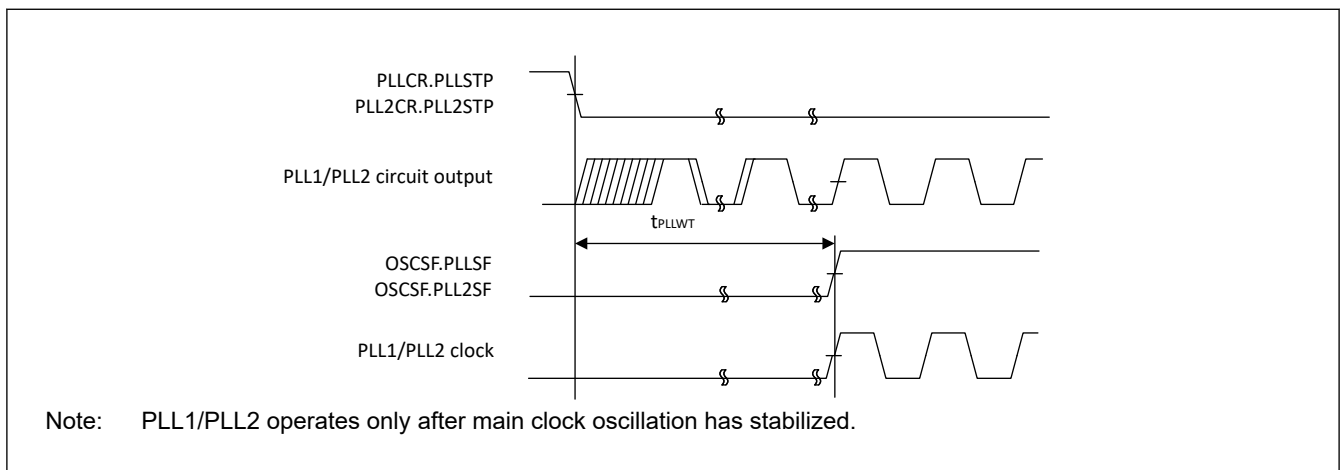

Figure 2.19 PLL1/PLL2 clock oscillation start timing

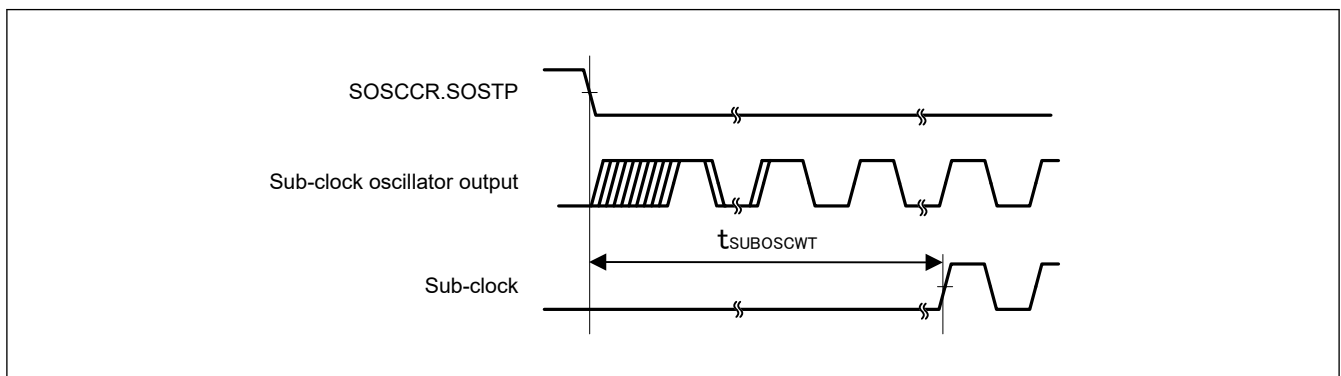

Figure 2.20 Sub-clock oscillation start timing

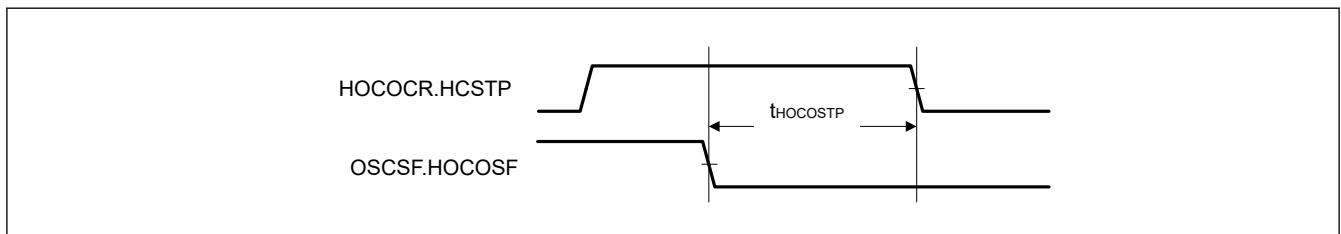

Figure 2.21 HOCO stop width time

2.3.3 Reset Timing

Table 2.33 Reset timing

Parameter		Symbol	Min	Typ	Max	Unit	Test conditions	
RES pulse width	Power-on	t_{RESWP}	4.2	—	—	ms	Figure 2.22	
	Deep Software Standby mode 1	DPSBYCR.DCSSMODE = 0	t_{RESWD}	1.30	—	—	ms	Figure 2.23
		DPSBYCR.DCSSMODE = 1		0.71	—	—		
	Deep Software Standby mode 2	DPSBYCR.DCSSMODE = 0	t_{RESWD}	2.00	—	—	ms	Figure 2.23
		DPSBYCR.DCSSMODE = 1		1.50	—	—		
	Deep Software Standby mode 3	DPSBYCR.DCSSMODE = 0	t_{RESWD}	3.50	—	—	ms	Figure 2.23
		DPSBYCR.DCSSMODE = 1		2.90	—	—		
	Software Standby mode		t_{RESWS}	0.66	—	—	ms	
	Low-speed Mode		t_{RESWLS}	0.46	—	—	ms	
	CPU Deep Sleep mode (SOSC operation)		$t_{RESWSODS}$	0.36	—	—	ms	
	CPU Deep Sleep mode (Other than SOSC operation)		t_{RESWDS}	0.24	—	—	ms	
	SOSC operation	PDCTRGD.PDDE = 1	t_{RESWSO}	0.19	—	—	ms	Figure 2.23
PDCTRGD.PDDE = 0		0.15		—	—			
Other than above	PDCTRGD.PDDE = 1	t_{RESW}	62.0	—	—	μ s	Figure 2.23	
	PDCTRGD.PDDE = 0		25.5	—	—			
Wait time after RES cancellation		t_{RESWT}	—	54.9	64.6	μ s	Figure 2.22	
Wait time after internal reset cancellation (IWDT reset, WDT reset, CPU Lockup reset, Bus Error reset, Common Memory Error reset, Software reset)		t_{RESW2}	—	54.9	64.6	μ s	—	

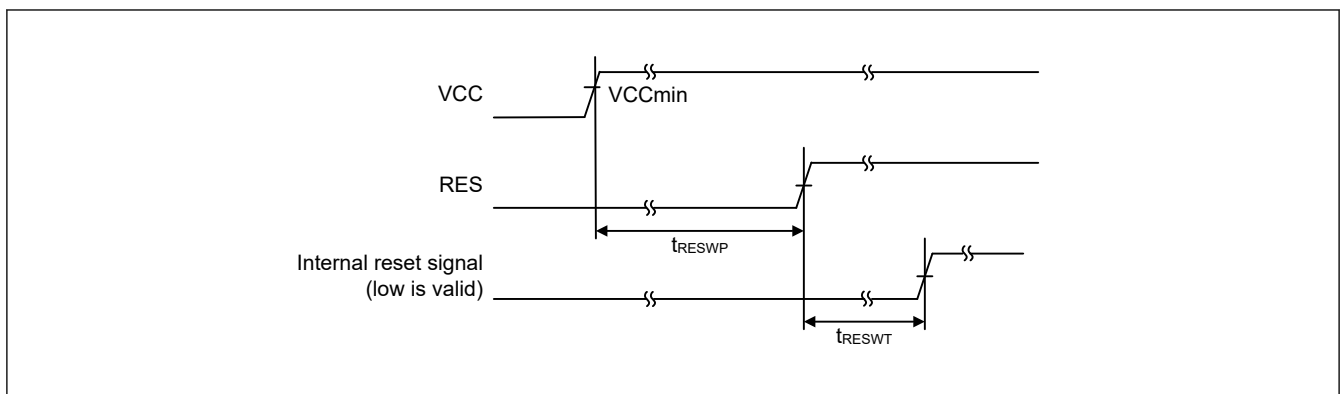

Figure 2.22 RES pin input timing under the condition that VCC exceeds V_{POR} voltage threshold

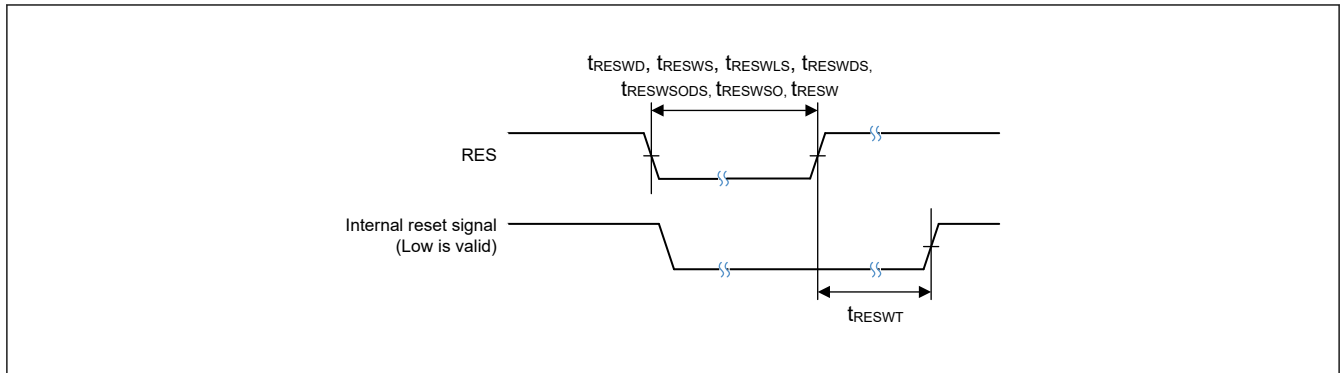

Figure 2.23 Reset input timing

2.3.4 Wakeup Timing

Table 2.34 Timing of recovery from low power modes (1 of 2)

Parameter	Fast return function	Symbol	Min	Typ	Max	Unit	Test conditions	
Recovery time from CPU Deep Sleep mode	—	$t_{DSL P}^{*10}$	—	182	214	μs	—	
Recovery time from Software Standby mode	Crystal resonator connected to main clock oscillator	System clock source is main clock oscillator* ¹ MOSCSCR.MOSCSOK P = 0	Enabled	t_{SBYMC}^{*9}	—	2.33	2.43	ms
		System clock source is main clock oscillator* ¹ MOSCSCR.MOSCSOK P = 1	Enabled	—	310	385	μs	
		System clock source is PLL1P with main clock oscillator* ² MOSCSCR.MOSCSOK P = 0	Enabled	t_{SBYPC}^{*9}	—	2.47	2.59	ms
		System clock source is PLL1P with main clock oscillator* ² MOSCSCR.MOSCSOK P = 1	Enabled	—	388	511	μs	
	External clock input to main clock oscillator	System clock source is main clock oscillator* ³	Enabled	t_{SBYEX}^{*9}	—	310	385	μs
		System clock source is PLL1P with main clock oscillator* ⁴	Enabled	t_{SBYPE}^{*9}	—	388	511	μs
	System clock source is sub-clock oscillator* ⁵	Enabled	t_{SBYSC}^{*9}	—	0.81	0.87	ms	
	System clock source is HOCO clock oscillator* ⁶	Enabled	t_{SBYHO}^{*9}	—	310	385	μs	
System clock source is PLL1P with HOCO* ⁷	Enabled	t_{SBYPH}^{*9}	—	398	522	μs		
System clock source is MOCO clock oscillator* ⁸	Enabled	t_{SBYMO}^{*9}	—	312	387	μs		

Figure 2.24
The division ratio of all oscillators is 1.

Table 2.34 Timing of recovery from low power modes (2 of 2)

Parameter			Fast return function	Symbol	Min	Typ	Max	Unit	Test conditions
Recovery time from Deep Software Standby mode	Deep Software Standby mode 1	Any of PVD0(OFS1(_SEC).PVDLPSEL=1), PVD1, PVD2, or Battery power supply switch is enabled	Standard	t_{DSBY}	—	0.68	1.20	ms	Figure 2.25
			Fast		—	0.29	0.62	ms	
		All of PVD0(OFS1(_SEC).PVDLPSEL=1), PVD1, PVD2, and Battery power supply switch are disabled	Standard		—	0.73	1.30		
			Fast		—	0.33	0.71		
	Deep Software Standby mode 2	DPSWCR.WSTS = 0x0B	Standard		—	0.73	1.10	ms	
			Fast		—	0.33	0.50	ms	
		DPSWCR.WSTS = 0x9A	Standard		—	1.60	2.00	ms	
			Fast		—	1.20	1.50	ms	
	Deep Software Standby mode 3	Standard			—	2.10	3.50	ms	
		Fast			—	1.70	2.90	ms	
Wait time after cancellation of Deep Software Standby mode			—	t_{DSBYWT}	47.7	—	64.6	μ s	

- Note 1. When the frequency of the crystal is 48 MHz (Main Clock Oscillator Wait Control Register (MOSCWTCR) is set to 0x05) and the greatest value of the internal clock division setting is 1.
- Note 2. When the frequency of PLL1P is 480 MHz (Main Clock Oscillator Wait Control Register (MOSCWTCR) is set to 0x05) and the greatest value of the internal clock division setting is 8.
- Note 3. When the frequency of the external clock is 48 MHz (Main Clock Oscillator Wait Control Register (MOSCWTCR) is set to 0x00) and the greatest value of the internal clock division setting is 1.
- Note 4. When the frequency of PLL1P is 480 MHz (Main Clock Oscillator Wait Control Register (MOSCWTCR) is set to 0x00) and the greatest value of the internal clock division setting is 8.
- Note 5. The Sub-clock oscillator frequency is 32.768 kHz and the greatest value of the internal clock division setting is 1.
- Note 6. The HOCO frequency is 20 MHz and the greatest value of the internal clock division setting is 1.
- Note 7. The PLL frequency is 480 MHz and the greatest value of the internal clock division setting is 8.
- Note 8. The MOCO frequency is 8 MHz and the greatest value of the internal clock division setting is 1.
- Note 9. The recovery time can be calculated with the equation of $t_{Common} + \max(t_{OSCSTB}, t_{PG1}, t_{PGCK}) + \max(t_{PG2}, t_{LPW})$. And they can be determined with the following values and equations. For n, the greatest value is selected from among the internal clock(CPUCLK, ICLK, PCLKm, FCLK, BCLK and EBCLK) division settings (m = A to E). t_{OSCSTB} in the table below means the time when each oscillator is active. When multiple oscillators are active, t_{OSCSTB} is determined by the longest t_{OSCSTB} among the active oscillators.
- Note 10. The ICLK frequency is 240 MHz. This recovery time corresponds to t_{PG2} .

Table 2.35 Each element of recovery time

Wakeup time	Oscillation keep	Fast return function	Typ							Max						Unit
			t _{Common}	t _{OSCSTB} *1	t _{PG1}	t _{PGCK}	t _{PG2}	t _{LPW}	t _{Common}	t _{OSCSTB} *1	t _{PG1}	t _{PGCK}	t _{PG2}	t _{LPW}		
t _{SBYMC}	MOSC disabled	Enabled	52.667 + 4/f _{ICLK}	t _{MAINOSC} WT	75.5	2.1 + 10.5/f _{MOCO} + 2.5n/f _{MOCO} + 2.5/f _{SRCCLK} + 2/f _{ICLK}	1449/f _{MOCO} + 10/f _{ICLK}	10 + 2/f _{ICLK} + 2n/f _{MAIN}	82.369 + 4/f _{ICLK}	t _{MAINOSC} WT + 11/0.236	88.8	2.5 + 10.5/f _{MOCO} + 2.5n/f _{MOCO} + 2.5/f _{SRCCLK} + 2/f _{ICLK}	1449/f _{MOCO} + 10/f _{ICLK}	10 + 2/f _{ICLK} + 2n/f _{MAIN}	μs	
	MOSC enabled	Enabled	52.667 + 4/f _{ICLK}	3/0.262				10 + 2/f _{ICLK} + 2n/f _{MAIN}	82.369 + 4/f _{ICLK}	14/0.236				10 + 2/f _{ICLK} + 2n/f _{MAIN}		μs
t _{SBYPC}	MOSC disabled	Enabled	52.667 + 4/f _{ICLK}	t _{MAINOSC} CWT + 31/0.262*2				10 + 2/f _{ICLK} + 2n/f _{PLL}	82.369 + 4/f _{ICLK}	24.05 + t _{MAINOSC} WT + 42/0.236*3				10 + 2/f _{ICLK} + 2n/f _{PLL}	μs	
	MOSC enabled	Enabled	52.667 + 4/f _{ICLK}	24.125 + 34/0.262*2				10 + 2/f _{ICLK} + 2n/f _{PLL}	82.369 + 4/f _{ICLK}	24.05 + 45/0.236*3				10 + 2/f _{ICLK} + 2n/f _{PLL}		μs
t _{SBYEX}	—	Enabled	52.667 + 4/f _{ICLK}	3/0.262				10 + 2/f _{ICLK} + 2n/f _{EXMAIN}	82.369 + 4/f _{ICLK}	14/0.236				10 + 2/f _{ICLK} + 2n/f _{EXMAIN}	μs	
t _{SBYPE}	—	Enabled	52.667 + 4/f _{ICLK}	24.125 + 34/0.262*2				10 + 2/f _{ICLK} + 2n/f _{PLL}	82.369 + 4/f _{ICLK}	24.05 + 45/0.236*3				10 + 2/f _{ICLK} + 2n/f _{PLL}	μs	
t _{SBYSC}	—	Enabled	52.667 + 4/f _{ICLK}	0				10 + 2/f _{ICLK} + 2n/f _{SOSC}	82.369 + 4/f _{ICLK}	0				10 + 2/f _{ICLK} + 2n/f _{SOSC}	μs	
t _{SBYHO}	—	Enabled	52.667 + 4/f _{ICLK}	23.375				10 + 2/f _{ICLK} + 2n/f _{HOCO}	82.369 + 4/f _{ICLK}	70.234				10 + 2/f _{ICLK} + 2n/f _{HOCO}	μs	
t _{SBYPH}	—	Enabled	52.667 + 4/f _{ICLK}	24.125 + 140*2				10 + 2/f _{ICLK} + 2n/f _{PLL}	82.369 + 4/f _{ICLK}	24.05 + 202*3				10 + 2/f _{ICLK} + 2n/f _{PLL}	μs	
t _{SBYMO}	—	Enabled	52.667 + 4/f _{ICLK}	0				10 + 2/f _{ICLK} + 2n/f _{MOCO}	82.369 + 4/f _{ICLK}	0				10 + 2/f _{ICLK} + 2n/f _{MOCO}	μs	

Note: The unit of frequency is MHz.

Note 1. If more than one oscillator is operating, the largest value of the operating oscillator in this column is applied.

Note 2. "24.125" can be reduced when both PLL1LDOCR.SKEEP and PLL2LDOCR.SKEEP are 1.

Note 3. "24.05" can be reduced when both PLL1LDOCR.SKEEP and PLL2LDOCR.SKEEP are 1.

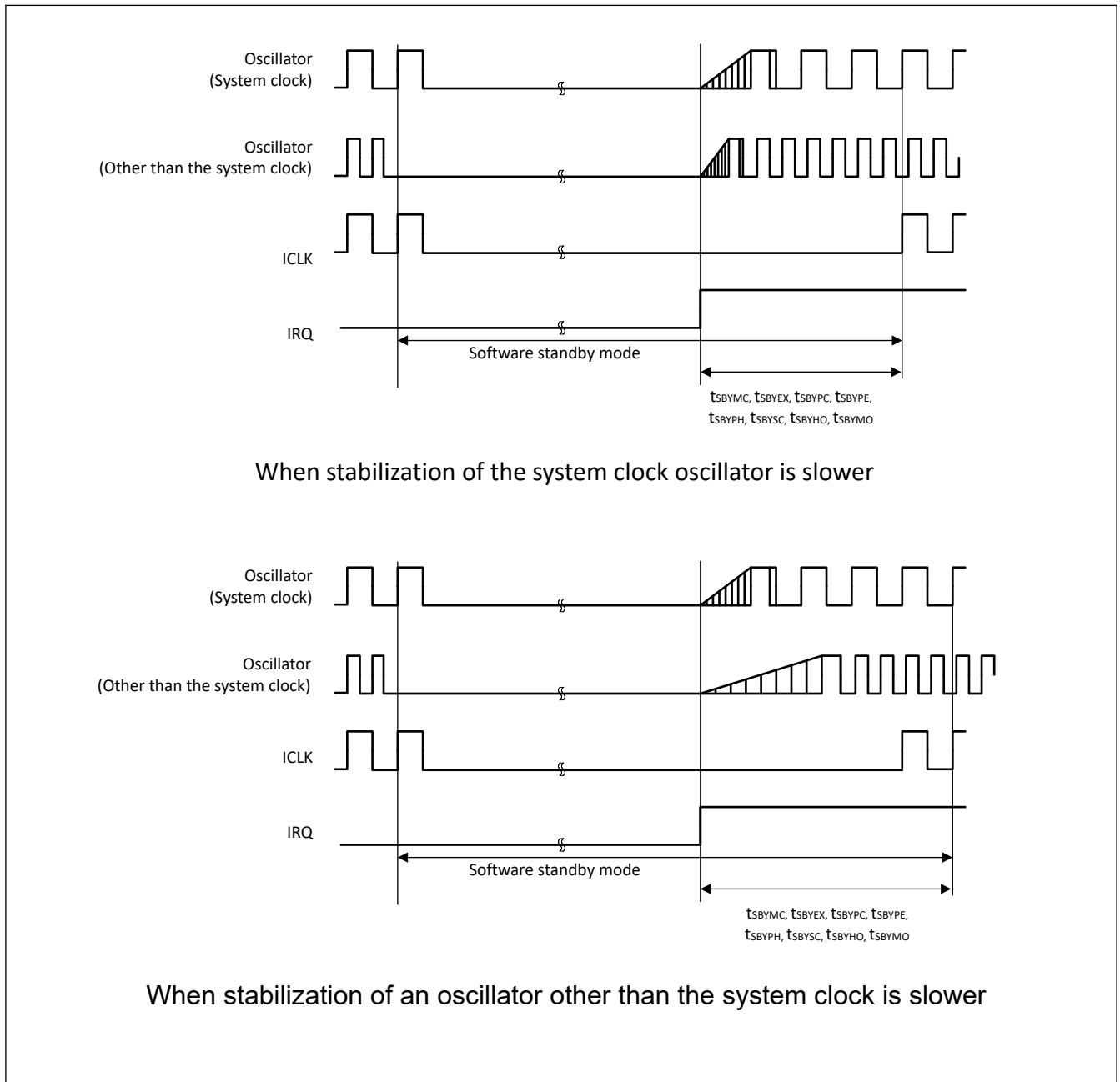

Figure 2.24 Software Standby mode cancellation timing

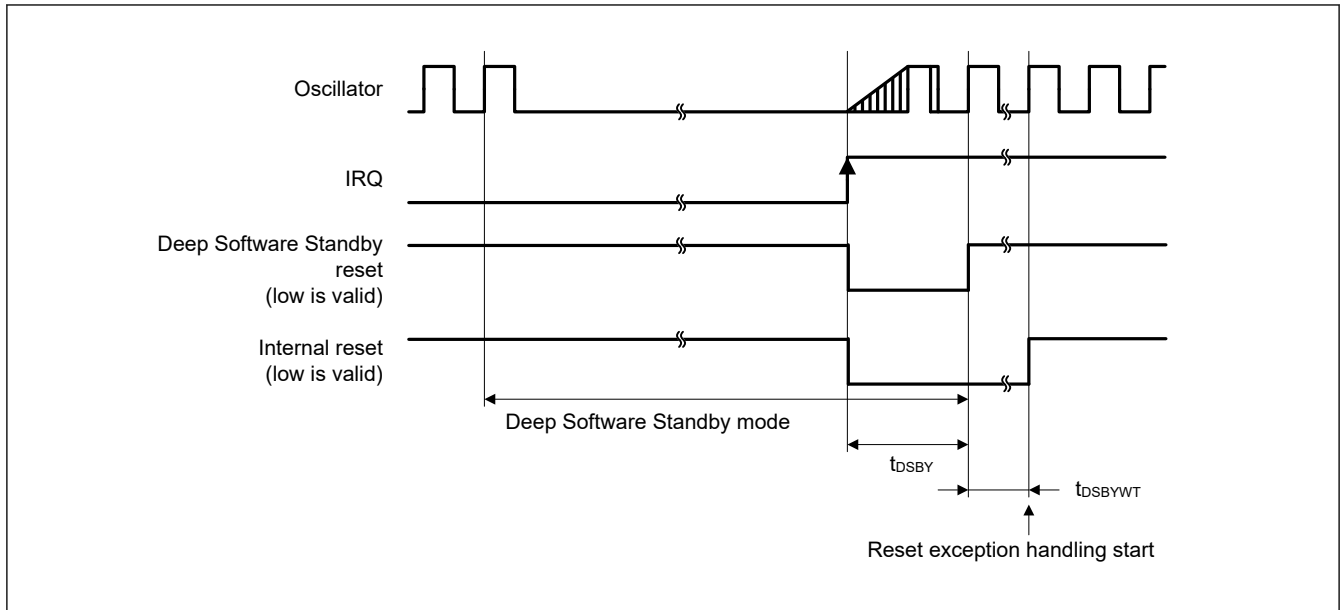

Figure 2.25 Deep Software Standby mode cancellation timing

2.3.5 NMI and IRQ Noise Filter

Table 2.36 NMI and IRQ noise filter

Parameter	Symbol	Min	Typ	Max	Unit	Test conditions	
NMI pulse width	t_{NMIW}	200	—	—	ns	NMI digital filter disabled	$t_{Pcyc} \times 2 \leq 200$ ns
		$t_{Pcyc} \times 2^{*1}$	—	—			$t_{Pcyc} \times 2 > 200$ ns
		200	—	—		NMI digital filter enabled	$t_{NMICK} \times 3 \leq 200$ ns
		$t_{NMICK} \times 3.5^{*2}$	—	—			$t_{NMICK} \times 3 > 200$ ns
IRQ pulse width	t_{IRQW}	200	—	—	ns	IRQ digital filter disabled	$t_{Pcyc} \times 2 \leq 200$ ns
		$t_{Pcyc} \times 2^{*1}$	—	—			$t_{Pcyc} \times 2 > 200$ ns
		200	—	—		IRQ digital filter enabled	$t_{IRQCK} \times 3 \leq 200$ ns
		$t_{IRQCK} \times 3.5^{*3}$	—	—			$t_{IRQCK} \times 3 > 200$ ns

- Note: 200 ns minimum in Software Standby mode.
- Note: If the system clock source is switched, add 4 clock cycles of the switched source.
- Note 1. t_{Pcyc} indicates the PCLKB cycle.
- Note 2. t_{NMICK} indicates the cycle of the NMI digital filter sampling clock.
- Note 3. t_{IRQCK} indicates the cycle of the IRQi digital filter sampling clock.

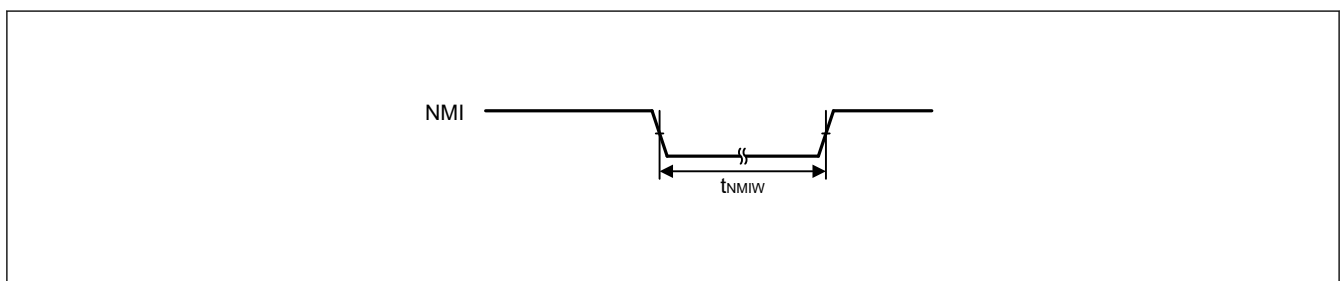

Figure 2.26 NMI interrupt input timing

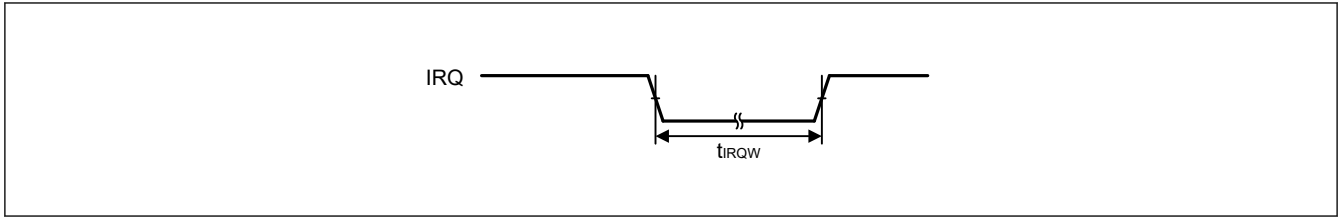

Figure 2.27 IRQ interrupt input timing

2.3.6 Bus Timing

Table 2.37 Bus timing (1 of 2)

Condition 1: When using the CS area controller (CSC).

VCC = VCC_DCDC = VCC_USB = VBATT = 1.68 V to 3.6 V, VCC2 = 1.65 V to 3.6 V

BCLK = 8 to 120 MHz, EBCLK = 8 to 60 MHz (When VCC = VCC_USB = VBATT = 2.70 to 3.6 V)

BCLK = 8 to 60 MHz, EBCLK = 8 to 30 MHz (When VCC = VCC_USB = VBATT = 1.68 to 3.6 V)

Output load conditions: VOH = VCC × 0.5, VOL = VCC × 0.5, C = 30 pF

EBCLK: High drive output is selected in the port drive capability bit in the PmnPFS register.

Others: Middle drive output is selected in the port drive capability bit in the PmnPFS register.

Condition 2: When using the SDRAM area controller (SDRAMC).

BCLK = SDCLK = 8 to 120 MHz

VCC = VCC2 = VCC_DCDC = VCC_USB = VBATT = 3.0 to 3.6 V

Output load conditions: VOH = VCC × 0.5, VOL = VCC × 0.5, C = 15 pF

SDCLK: High-speed high drive output is selected in the port drive capability bit in the PmnPFS register.

Others: High drive output is selected in the port drive capability bit in the PmnPFS register.

Condition 3: When using the SDRAM area controller (SDRAMC) and CS area controller (CSC) simultaneously.

BCLK = SDCLK = 8 to 60 MHz

VCC = VCC2 = VCC_DCDC = VCC_USB = VBATT = 3.0 to 3.6 V

Output load conditions: VOH = VCC × 0.5, VOL = VCC × 0.5, C = 15 pF

EBCLK/SDCLK: High drive output is selected in the port drive capability bit in the PmnPFS register.

Others: Middle drive output is selected in the port drive capability bit in the PmnPFS register.

Parameter		Symbol	Min	Max	Unit	Test conditions
Address delay	2.70V or above	t_{AD}	1.0	12.5	ns	Figure 2.28 to Figure 2.34
	1.68V or above		1.0	12.5	ns	
Byte control delay	2.70V or above	t_{BCD}	1.0	12.5	ns	
	1.68V or above		1.0	12.5	ns	
CS delay	2.70V or above	t_{CSD}	1.0	12.5	ns	
	1.68V or above		1.0	12.5	ns	
ALE delay time	2.70V or above	t_{ALED}	1.0	12.5	ns	
	1.68V or above		1.0	12.5	ns	
RD delay	2.70V or above	t_{RSD}	1.0	12.5	ns	
	1.68V or above		1.0	12.5	ns	
Read data setup time	2.70V or above	t_{RDS}	12.5	—	ns	
	1.68V or above		20.5	—	ns	
Read data hold time	2.70V or above	t_{RDH}	0	—	ns	
	1.68V or above		0	—	ns	
WR/WRn delay	2.70V or above	t_{WRD}	1.0	12.5	ns	
	1.68V or above		1.0	12.5	ns	
Write data delay	2.70V or above	t_{WDD}	—	12.5	ns	
	1.68V or above		—	12.5	ns	
Write data hold time	2.70V or above	t_{WDH}	1.0	—	ns	
	1.68V or above		1.0	—	ns	
WAIT setup time	2.70V or above	t_{WTS}	12.5	—	ns	
	1.68V or above		20.5	—	ns	
WAIT hold time	2.70V or above	t_{WTH}	0	—	ns	
	1.68V or above		0	—	ns	

Table 2.37 Bus timing (2 of 2)

Condition 1: When using the CS area controller (CSC).

VCC = VCC_DCDC = VCC_USB = VBATT = 1.68 V to 3.6 V, VCC2 = 1.65 V to 3.6 V

BCLK = 8 to 120 MHz, EBCLK = 8 to 60 MHz (When VCC = VCC_USB = VBATT = 2.70 to 3.6 V)

BCLK = 8 to 60 MHz, EBCLK = 8 to 30 MHz (When VCC = VCC_USB = VBATT = 1.68 to 3.6 V)

Output load conditions: VOH = VCC × 0.5, VOL = VCC × 0.5, C = 30 pF

EBCLK: High drive output is selected in the port drive capability bit in the PmnPFS register.

Others: Middle drive output is selected in the port drive capability bit in the PmnPFS register.

Condition 2: When using the SDRAM area controller (SDRAMC).

BCLK = SDCLK = 8 to 120 MHz

VCC = VCC2 = VCC_DCDC = VCC_USB = VBATT = 3.0 to 3.6 V

Output load conditions: VOH = VCC × 0.5, VOL = VCC × 0.5, C = 15 pF

SDCLK: High-speed high drive output is selected in the port drive capability bit in the PmnPFS register.

Others: High drive output is selected in the port drive capability bit in the PmnPFS register.

Condition 3: When using the SDRAM area controller (SDRAMC) and CS area controller (CSC) simultaneously.

BCLK = SDCLK = 8 to 60 MHz

VCC = VCC2 = VCC_DCDC = VCC_USB = VBATT = 3.0 to 3.6 V

Output load conditions: VOH = VCC × 0.5, VOL = VCC × 0.5, C = 15 pF

EBCLK/SDCLK: High drive output is selected in the port drive capability bit in the PmnPFS register.

Others: Middle drive output is selected in the port drive capability bit in the PmnPFS register.

Parameter		Symbol	Min	Max	Unit	Test conditions
Address delay 2 (SDRAM)	Condition 2	t_{AD2}	0.8	6.8	ns	Figure 2.35 to Figure 2.41
	Condition 3		0.8	10.8		
CS delay 2 (SDRAM)	Condition 2	t_{CSD2}	0.8	6.8	ns	
	Condition 3		0.8	10.8		
DQM delay (SDRAM)	Condition 2	t_{DQMD}	0.8	6.8	ns	
	Condition 3		0.8	10.8		
CKE delay (SDRAM)	Condition 2	t_{CKED}	0.8	6.8	ns	
	Condition 3		0.8	10.8		
Read data setup time 2 (SDRAM)	Condition 2	t_{RDS2}	2.9	—	ns	
	Condition 3		6.9	—		
Read data hold time 2 (SDRAM)	Condition 2	t_{RDH2}	1.5	—	ns	
	Condition 3		1.5	—		
Write data delay 2 (SDRAM)	Condition 2	t_{WDD2}	—	6.8	ns	
	Condition 3		—	10.8		
Write data hold time 2 (SDRAM)	Condition 2	t_{WDH2}	0.8	—	ns	
	Condition 3		0.8	—		
WE delay (SDRAM)	Condition 2	t_{WED}	0.8	6.8	ns	
	Condition 3		0.8	10.8		
RAS delay (SDRAM)	Condition 2	t_{RASD}	0.8	6.8	ns	
	Condition 3		0.8	10.8		
CAS delay (SDRAM)	Condition 2	t_{CASD}	0.8	6.8	ns	
	Condition 3		0.8	10.8		

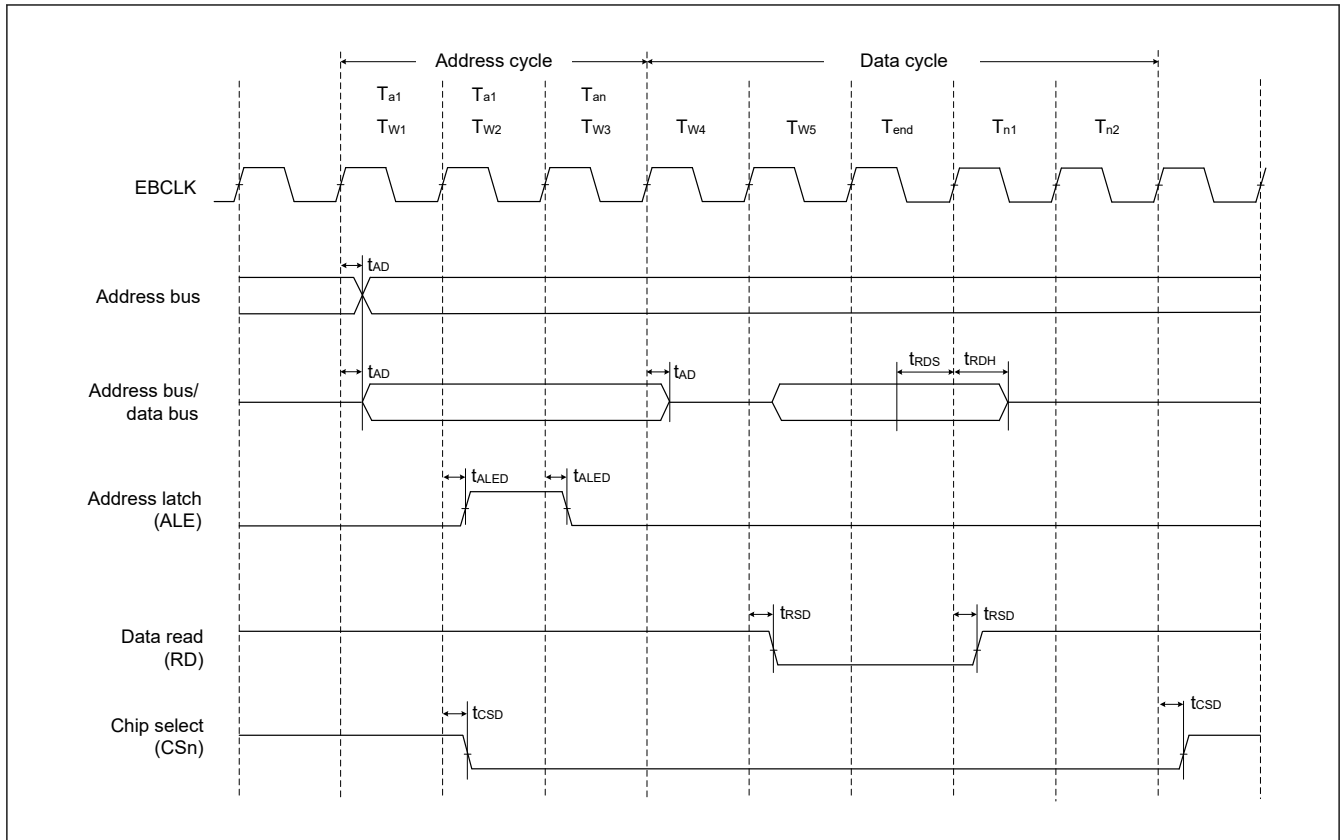

Figure 2.28 Address/data multiplexed bus read access timing

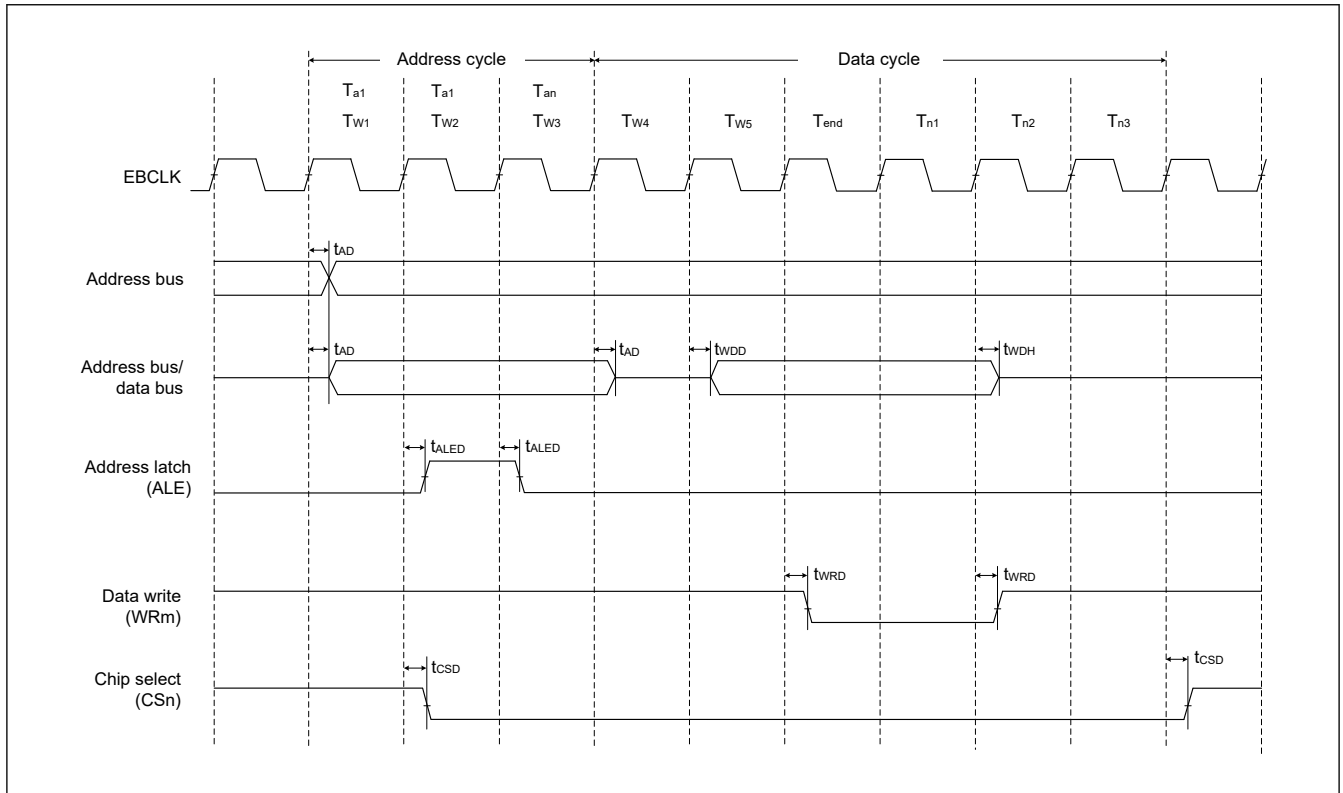

Figure 2.29 Address/data multiplexed bus write access timing

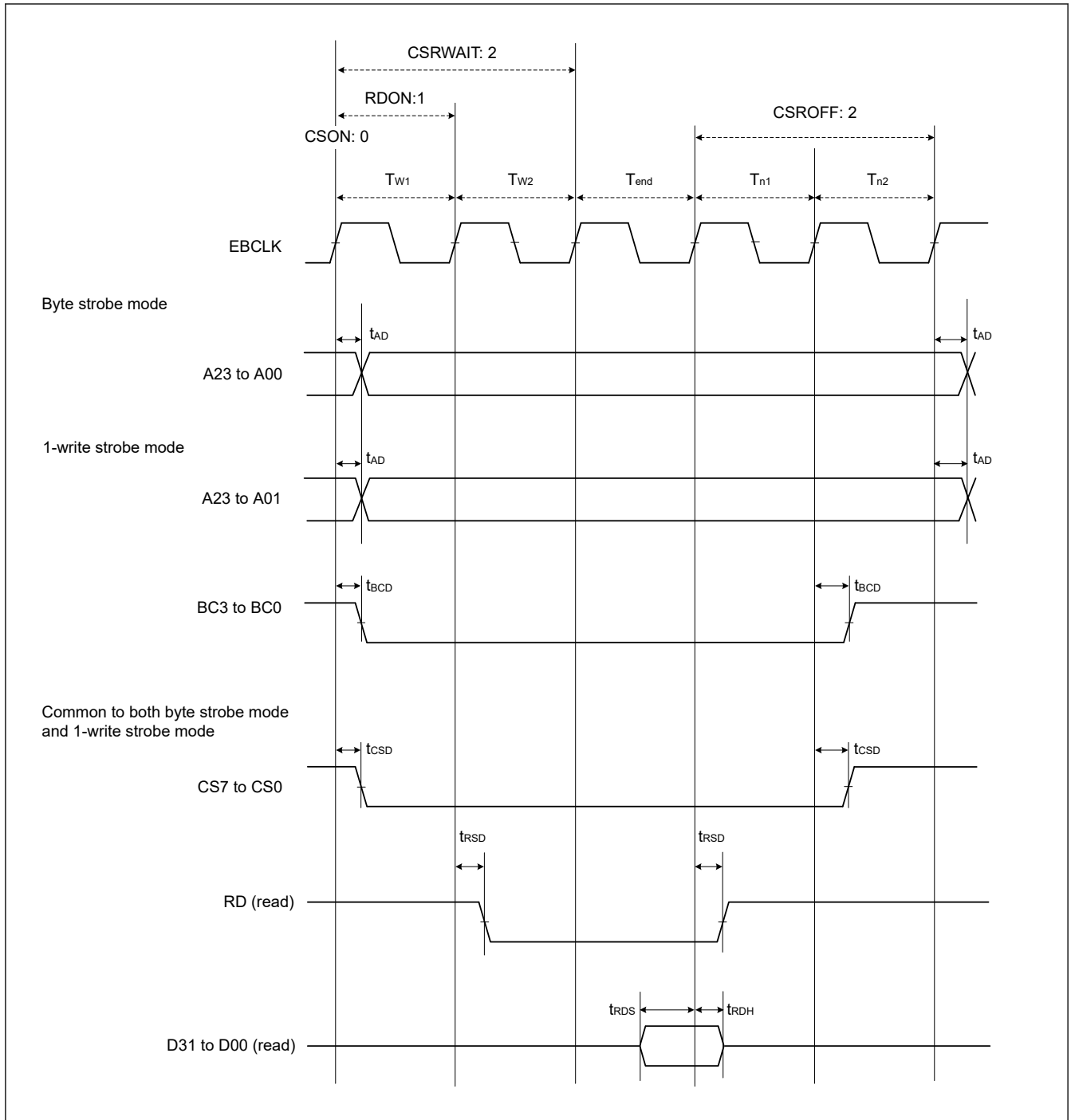

Figure 2.30 External bus timing for normal read cycle with bus clock synchronized

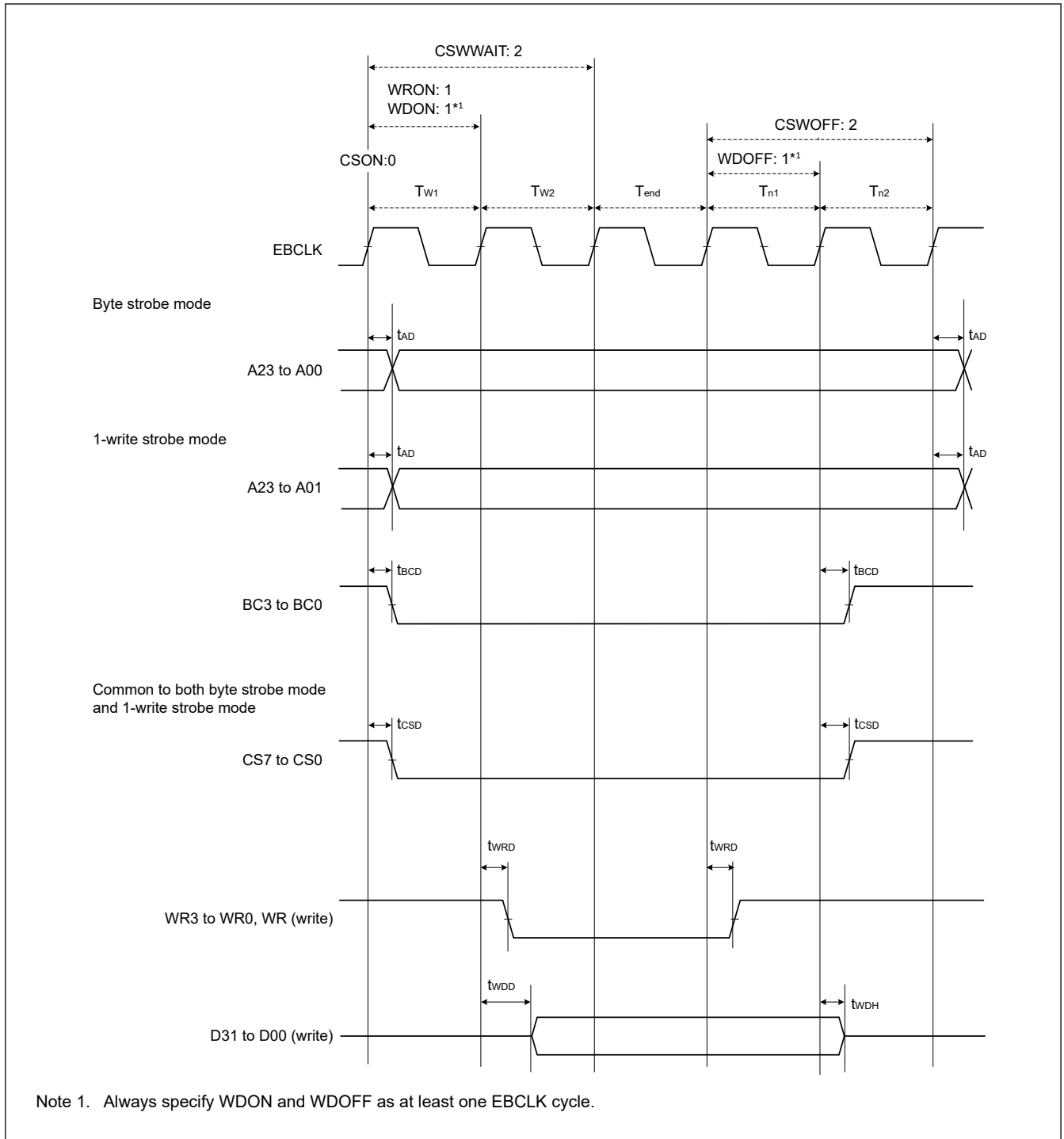

Figure 2.31 External bus timing for normal write cycle with bus clock synchronized

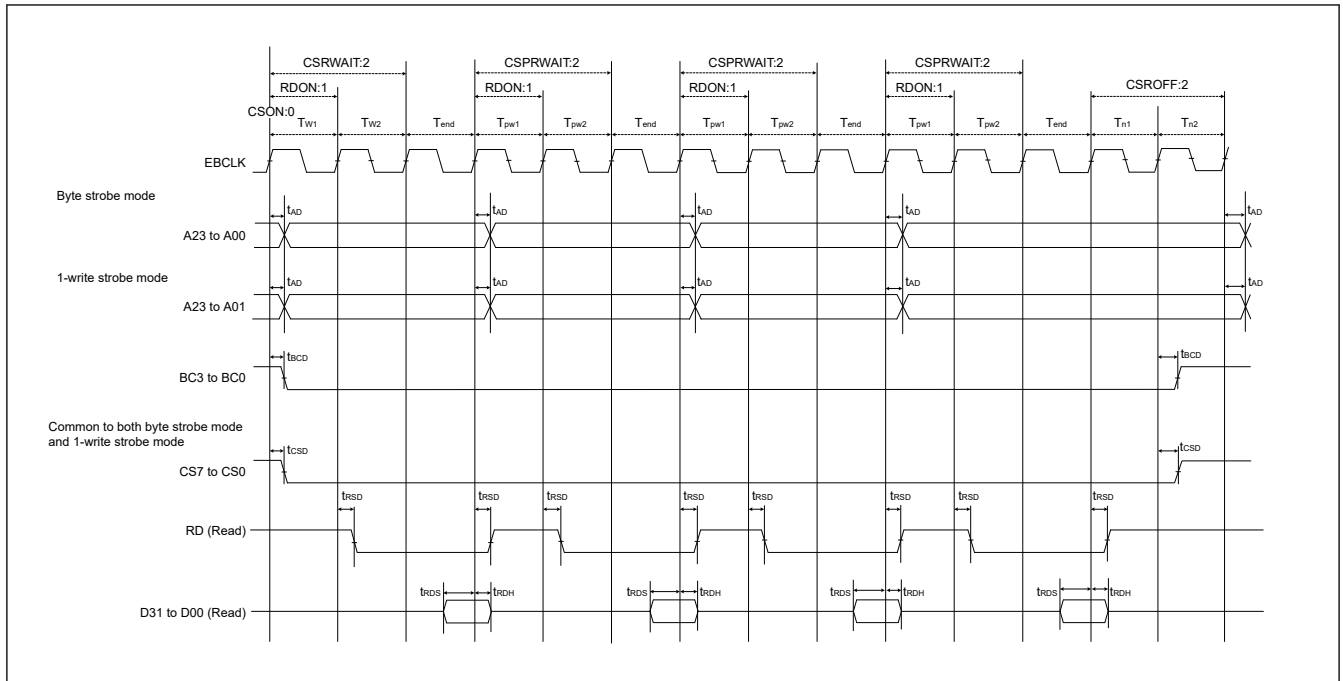
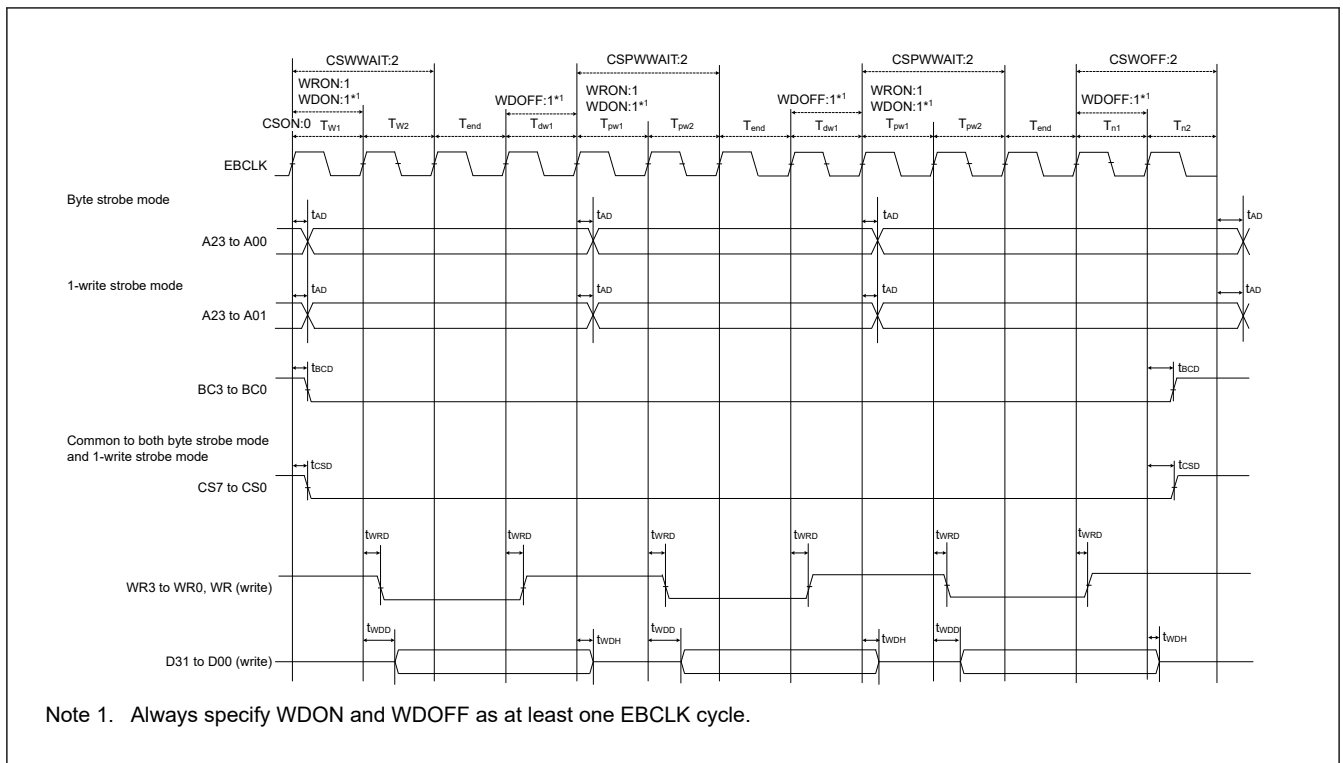

Figure 2.32 External bus timing for page read cycle with bus clock synchronized



Note 1. Always specify WDON and WDOFF as at least one EBCLK cycle.

Figure 2.33 External bus timing for page write cycle with bus clock synchronized

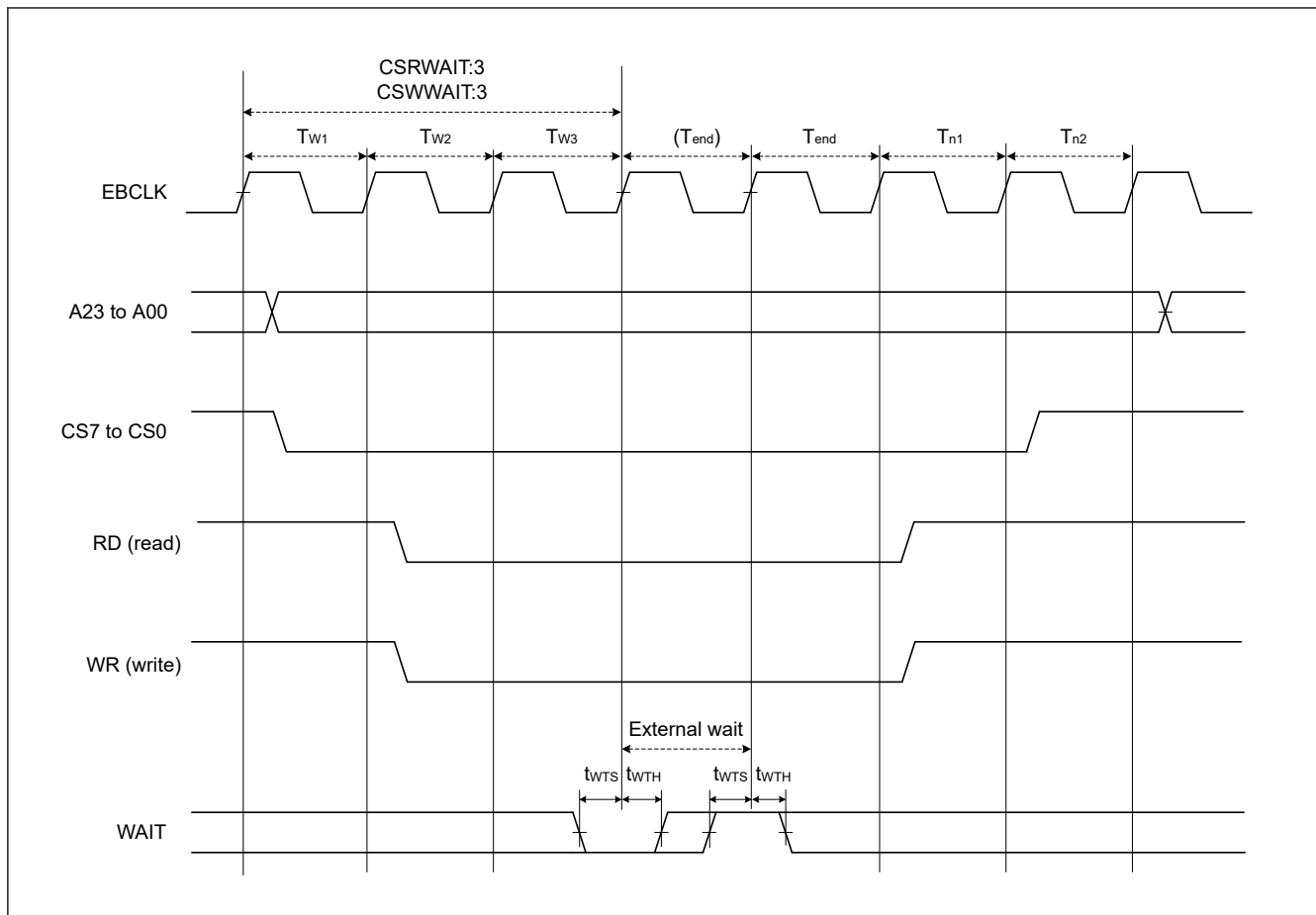

Figure 2.34 External bus timing for external wait control

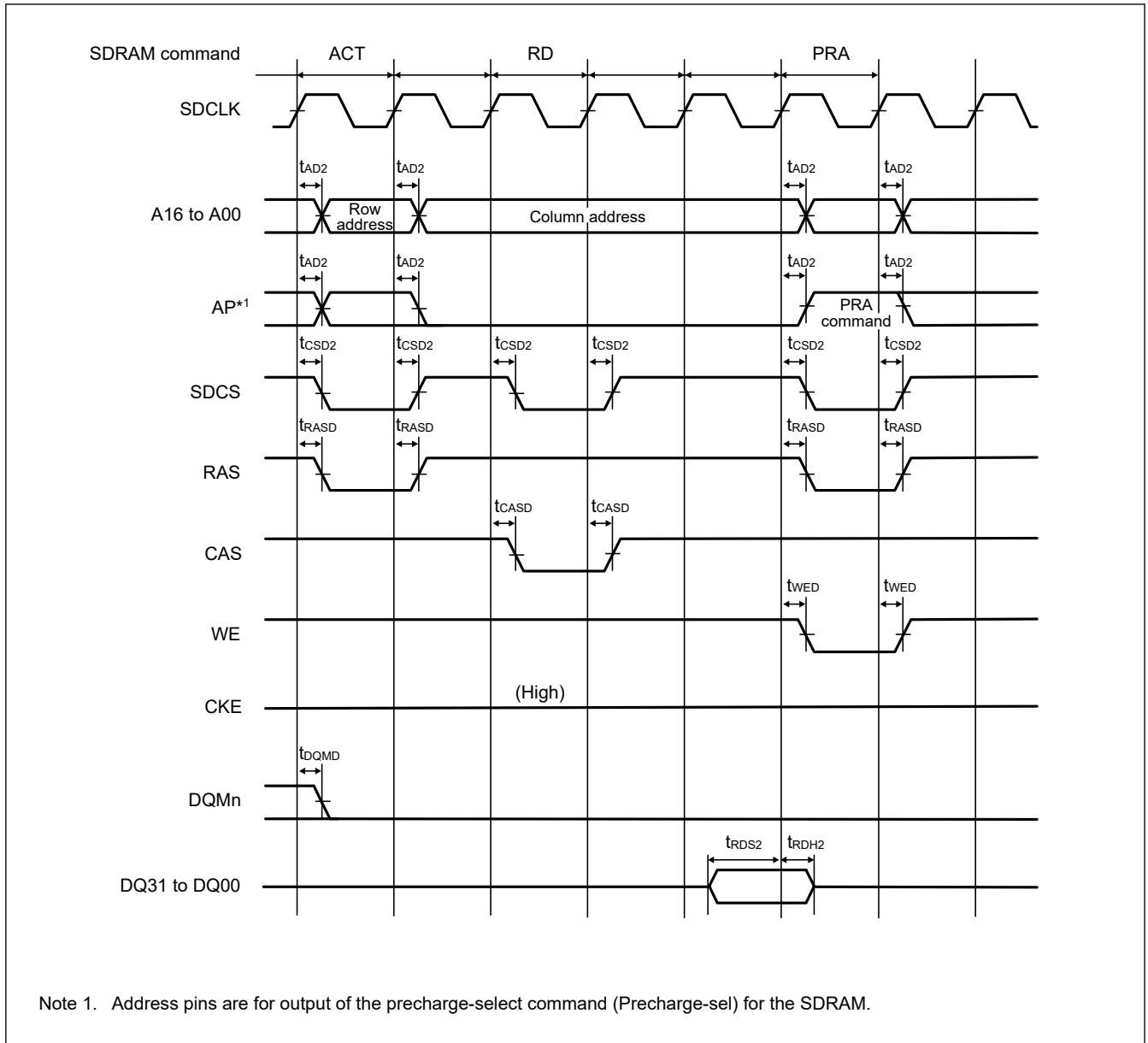

Figure 2.35 SDRAM single read timing

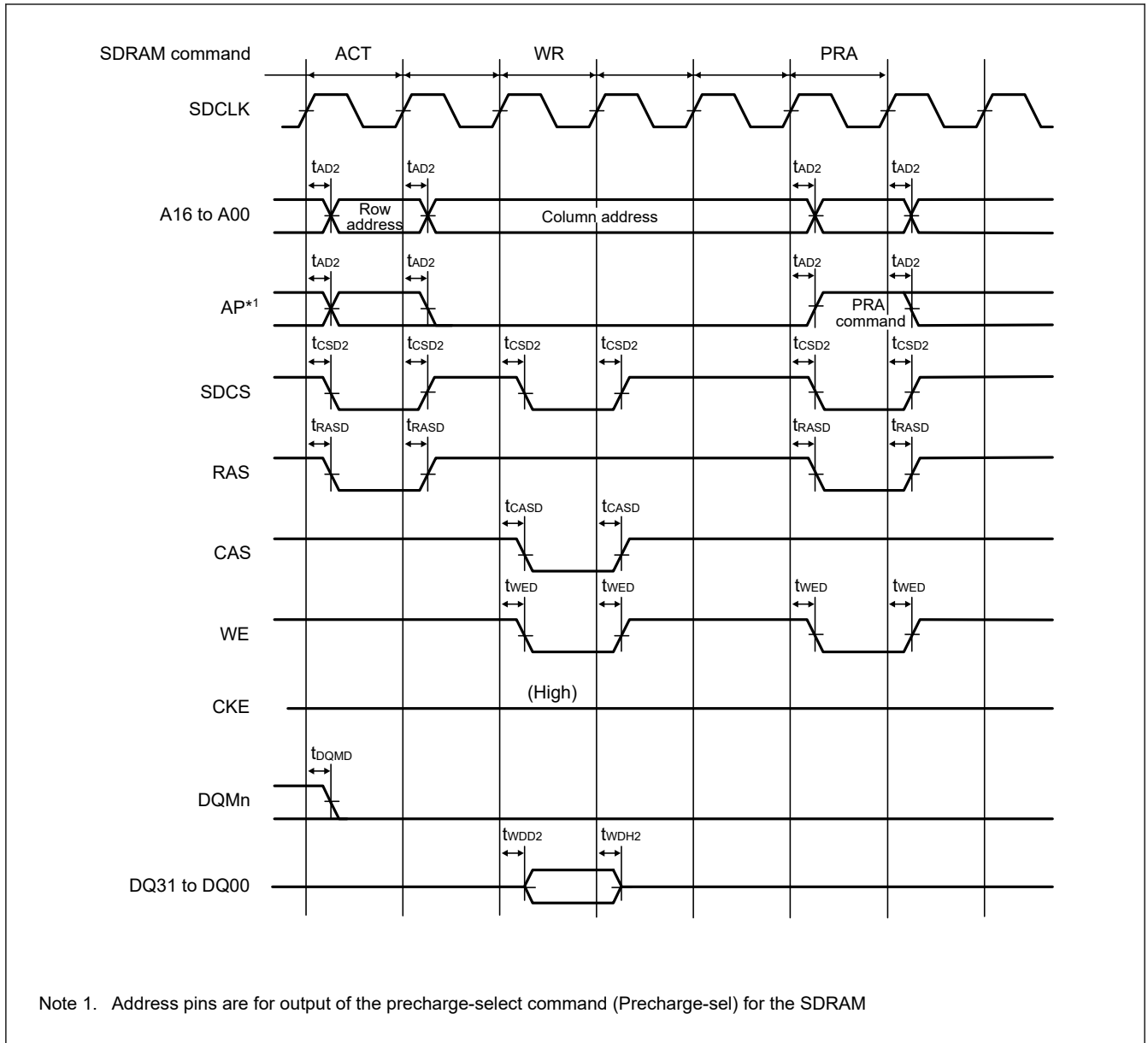
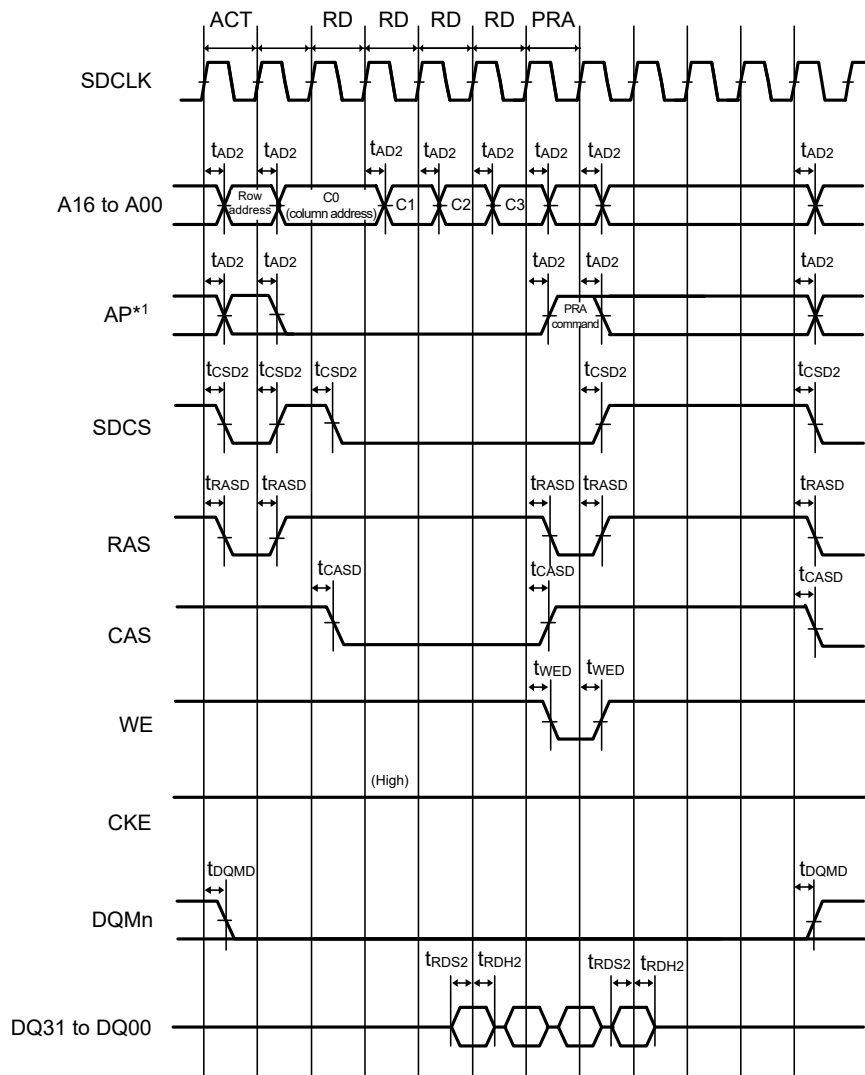
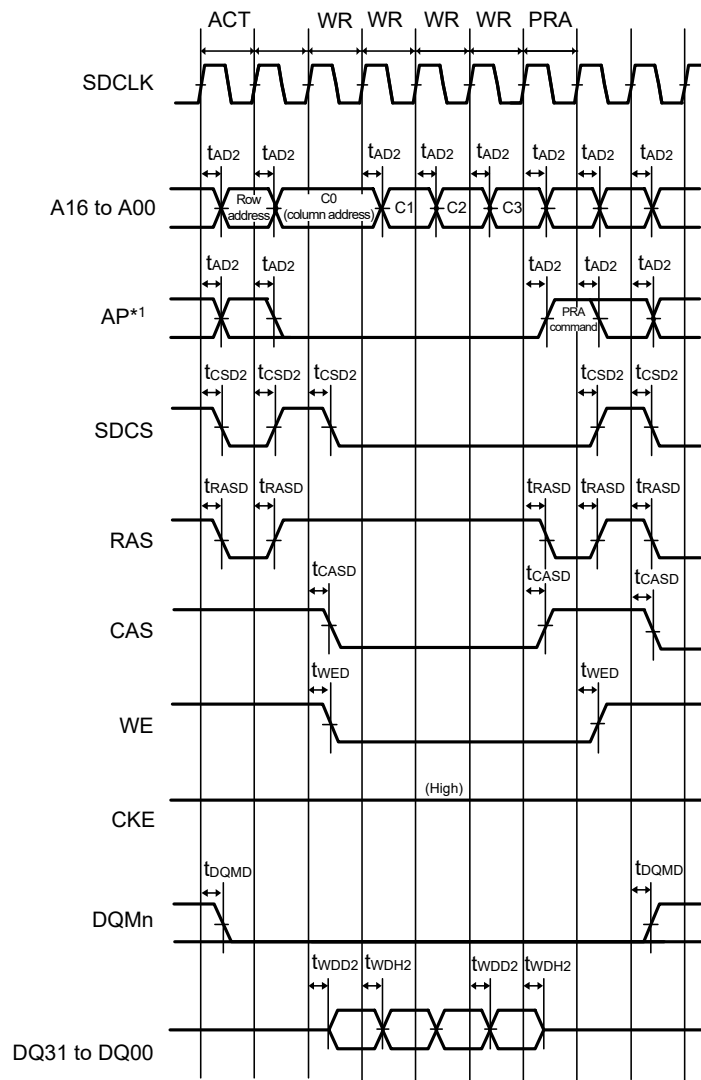

Figure 2.36 SDRAM single write timing



Note 1. Address pins are for output of the precharge-select command (Precharge-sel) for the SDRAM.

Figure 2.37 SDRAM multiple read timing



Note 1. Address pins are for output of the precharge-select command (Precharge-sel) for the SDRAM.

Figure 2.38 SDRAM multiple write timing

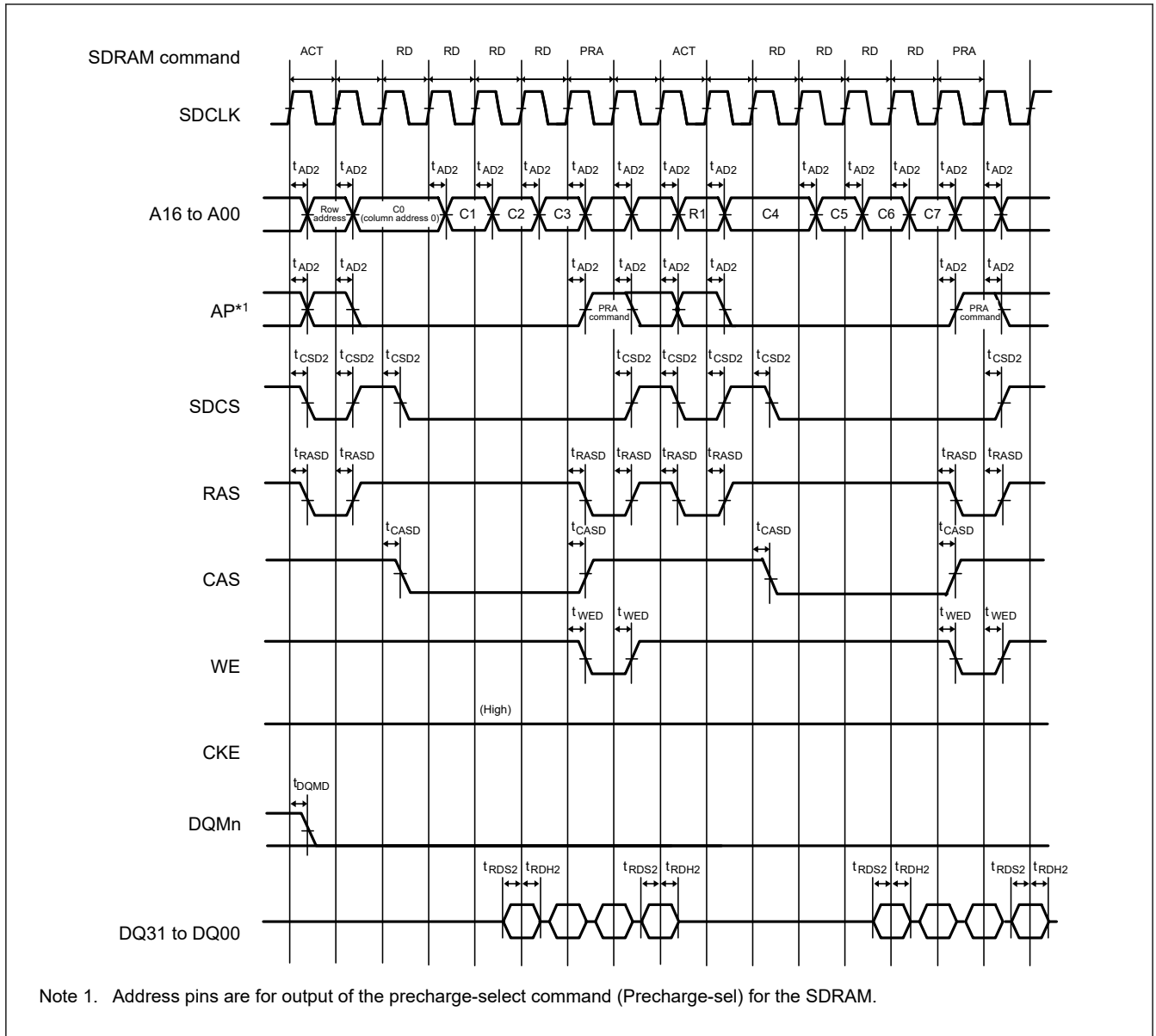

Figure 2.39 SDRAM multiple read line stride timing

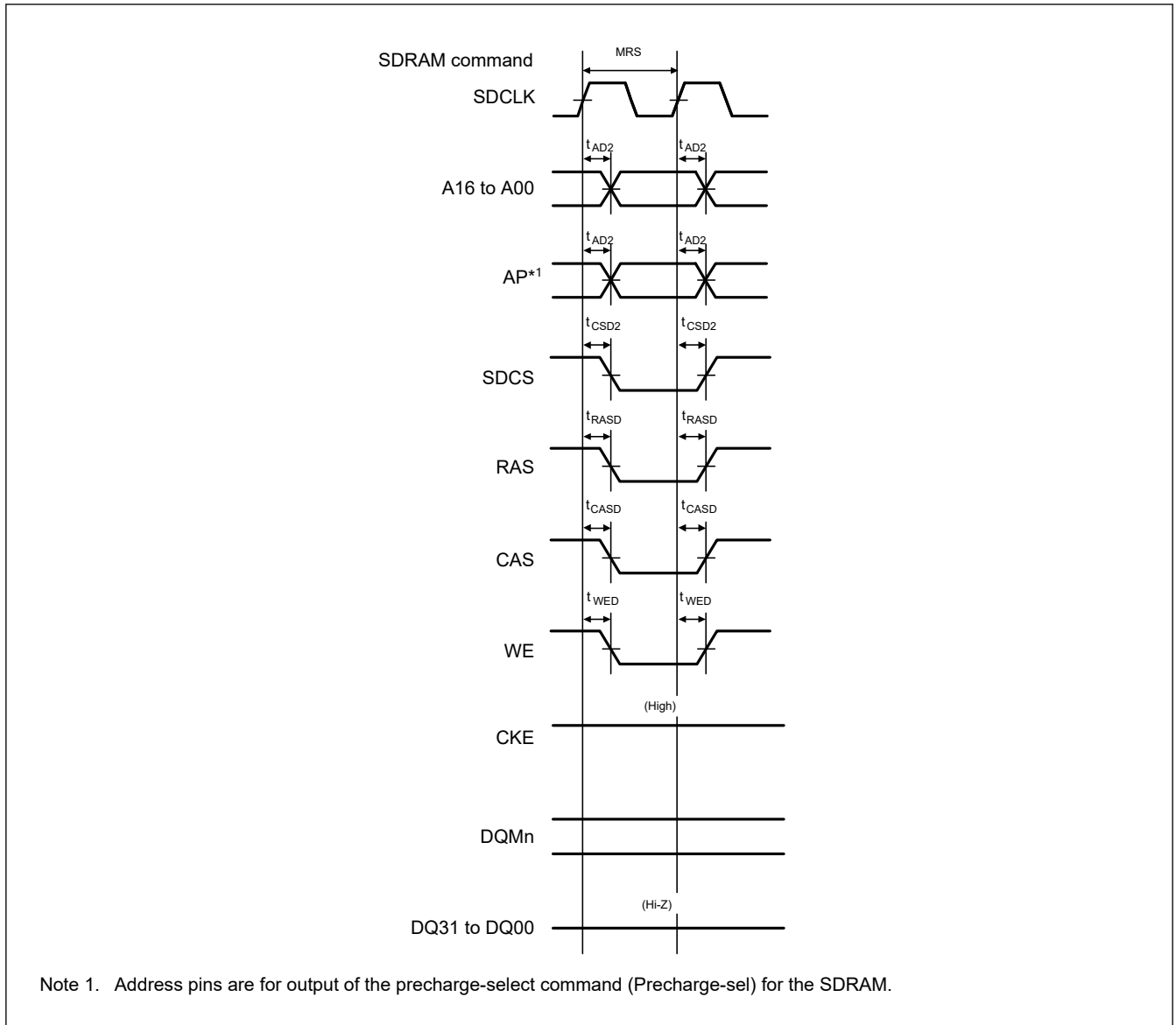

Figure 2.40 SDRAM mode register set timing

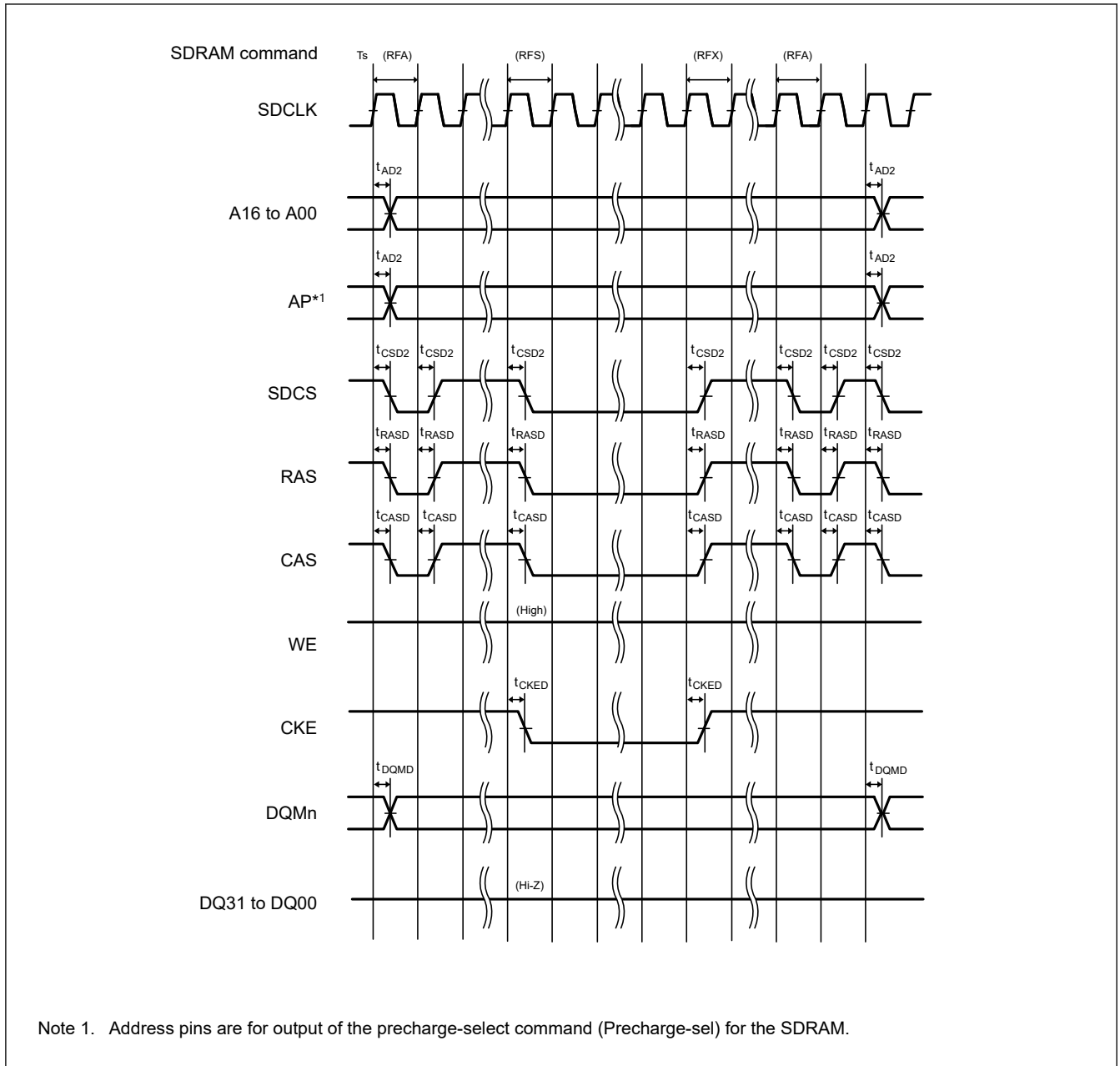

Figure 2.41 SDRAM self-refresh timing

2.3.7 I/O Ports, POEG, GPT, AGT, ULPT and ADC12 Trigger Timing

Table 2.38 I/O ports, POEG, GPT, AGT, ULPT and ADC12 trigger timing (1 of 3)

GPT Conditions:

Middle drive output is selected in the Port Drive Capability bit in the PmnPFS register.

If GPT pins are specified across the VCC I/O and VCC2 I/O, characteristics below is guaranteed only when VCC = VCC2.

AGT Conditions:

Middle drive output is selected in the Port Drive Capability bit in the PmnPFS register.

Parameter	Symbol	Min	Max	Unit	Test conditions	
I/O ports	Input data pulse width	t_{PRW}	5.5	—	t_{cyc}	Figure 2.42
	EXCIN input frequency	t_{EXCIN}	—	36	kHz	
	RTCICn (n = 0 to 2) input pulse width	t_{RTCICW}	13.89	—	μs	Figure 2.43
POEG	POEG input trigger pulse width	t_{POEW}	3	—	t_{Pcyc}	Figure 2.44

Table 2.38 I/O ports, POEG, GPT, AGT, ULPT and ADC12 trigger timing (2 of 3)

GPT Conditions:

Middle drive output is selected in the Port Drive Capability bit in the PmnPFS register.

If GPT pins are specified across the VCC I/O and VCC2 I/O, characteristics below is guaranteed only when VCC = VCC2.

AGT Conditions:

Middle drive output is selected in the Port Drive Capability bit in the PmnPFS register.

Parameter		Symbol	Min	Max	Unit	Test conditions	
GPT	Input capture pulse width (Cycle)	Single edge	t_{GTICW}^{*1}	1.5	—	t_{pDcyc}	Figure 2.45
		Dual edge		2.5	—		
	Input capture pulse width (Time)	2.70V or above	t_{GTICW}^{*1}	12.5	—	ns	
		1.68V or above (VCC)		25.0	—		
		1.65V or above (VCC2)					
	GTIOCxY output skew (x = 0 to 7, Y = A or B)	2.70V or above	t_{GTISK}	—	4	ns	
		1.68V or above (VCC)		—	5		
	GTIOCxY output skew (x = 8 to 13, Y = A or B)	2.70V or above	t_{GTISK}	—	4	ns	
		1.68V or above (VCC)		—	5		
	GTIOCxY output skew (x = 0 to 13, Y = A or B)	2.70V or above	t_{GTISK}	—	6	ns	
		1.68V or above (VCC)		—	7		
	OPS output skew GTOUUP, GTOULO, GTOVUP, GTOVLO, GTOWUP, GTOWLO	2.70V or above	t_{GTOSK}	—	5	ns	Figure 2.47
1.68V or above (VCC)		—		6			
AGT	AGTIO, AGTEE input cycle	t_{ACYC}^{*2}	2.70V or above	100	—	ns	Figure 2.48
			1.68V or above (VCC)	100	—		
			1.65V or above (VCC2)				
	AGTIO, AGTEE input high width, low width	t_{ACKWH}, t_{ACKWL}	2.70V or above	40	—	ns	
			1.68V or above (VCC)	40	—		
	AGTIO, AGTO, AGTOA, AGTOB output cycle	t_{ACYC2}	2.70V or above	62.5	—	ns	
1.68V or above (VCC)			62.5	—			
			1.65V or above (VCC2)				

Table 2.38 I/O ports, POEG, GPT, AGT, ULPT and ADC12 trigger timing (3 of 3)

GPT Conditions:

Middle drive output is selected in the Port Drive Capability bit in the PmnPFS register.

If GPT pins are specified across the VCC I/O and VCC2 I/O, characteristics below is guaranteed only when VCC = VCC2.

AGT Conditions:

Middle drive output is selected in the Port Drive Capability bit in the PmnPFS register.

Parameter		Symbol	Min	Max	Unit	Test conditions
ULPT	ULPTEE, ULPTEVI input cycle	2.70V or above	32	-	μs	Figure 2.49
		1.68V or above (VCC) 1.65V or above (VCC2)	32	-		
	ULPTEE, ULPTVI input high width, low width	2.70V or above	12	-	μs	
		1.68V or above (VCC) 1.65V or above (VCC2)	12	-		
	ULPTO, ULPTOA, ULPTOB output cycle	2.70V or above	64	-	μs	
		1.68V or above (VCC) 1.65V or above (VCC2)	64	-		
ADC12	ADC12 trigger input pulse width	2.70V or above	1.5	—	t _{P_{cy}}	Figure 2.50
		1.68V or above (VCC) 1.65V or above (VCC2)	3.0	—		

Note: t_{IC_{yc}}: ICLK cycle, t_{P_{cy}}: PCLKB cycle, t_{PD_{cy}}: PCLKD cycle, t_{ULPTLCLK}: ULPTLCLK cycle..

Note 1. For Cycle and Time, the longer time characteristics is applied.

Note 2. Constraints on input cycle:

When not switching the source clock: t_{P_{cy}} × 2 < t_{AC_{yc}} should be satisfied.

When switching the source clock: t_{P_{cy}} × 6 < t_{AC_{yc}} should be satisfied.

Note 3. Constraints on input cycle:

ULPTEVI : t_{P_{cy}} × 2 < t_{ULCYC} should be satisfied.

ULPTEE: t_{ULPTLCLK} × 2 < t_{ULCYC} should be satisfied.

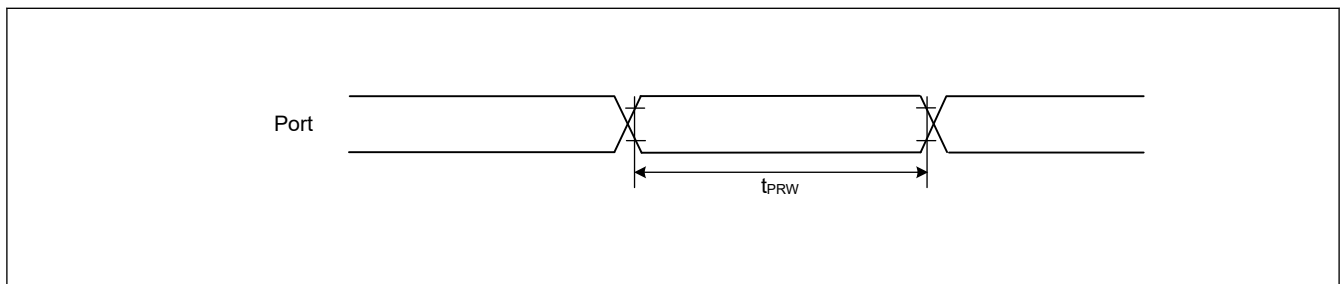

Figure 2.42 I/O ports input timing

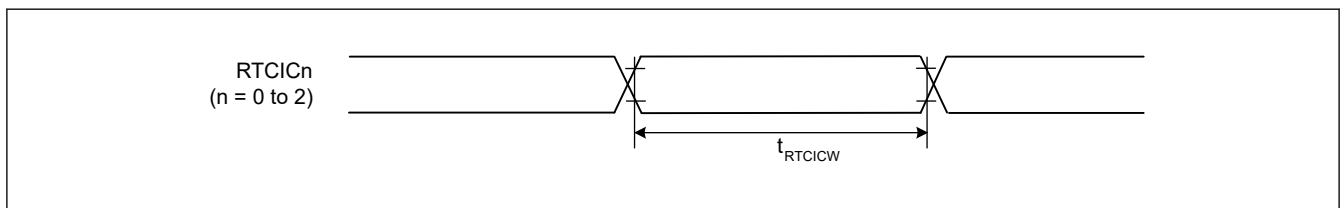

Figure 2.43 RTCICn input timing

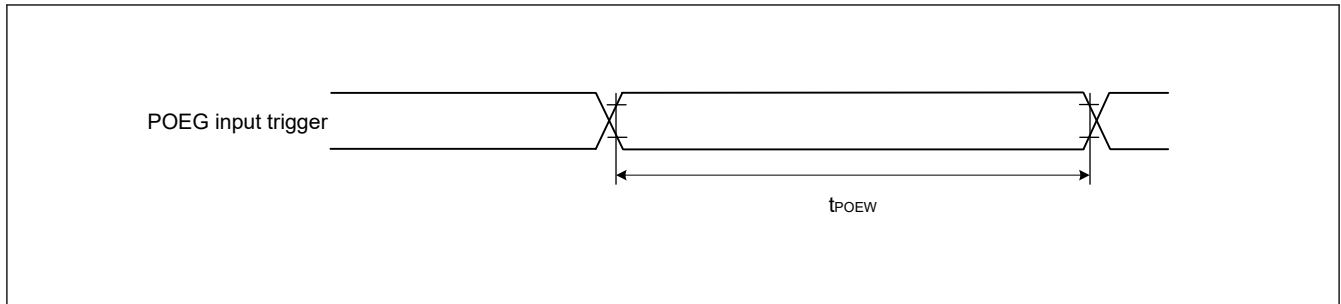

Figure 2.44 POEG input trigger timing

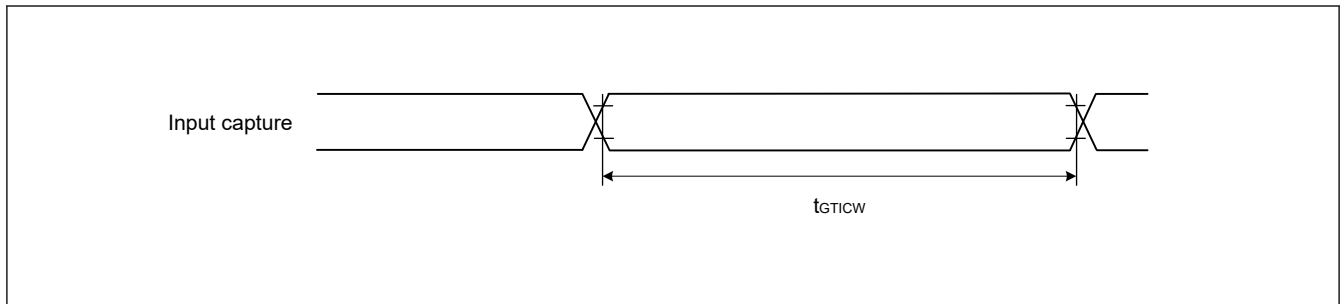

Figure 2.45 GPT input capture timing

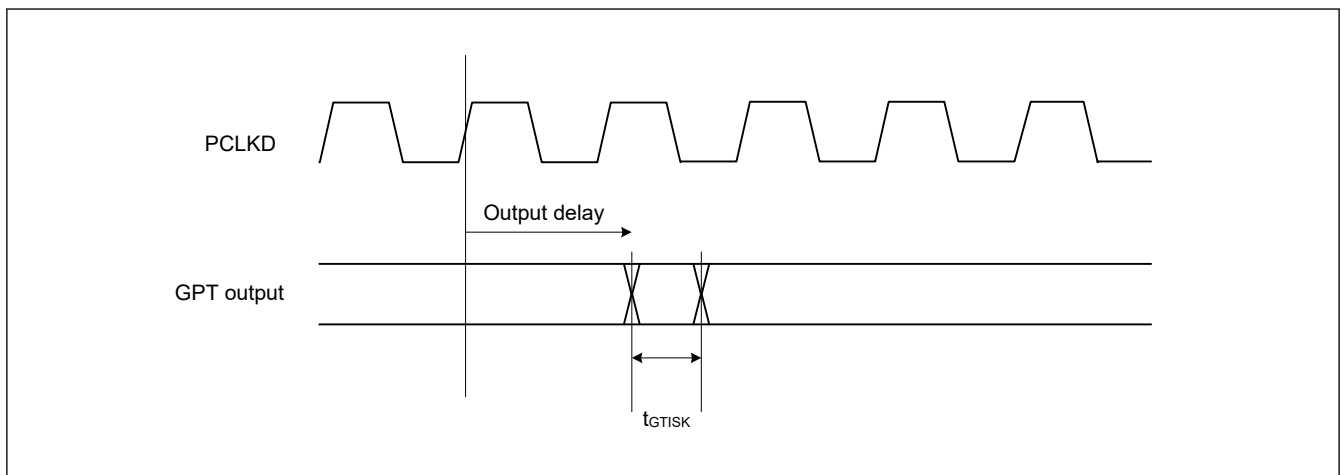

Figure 2.46 GPT output delay skew

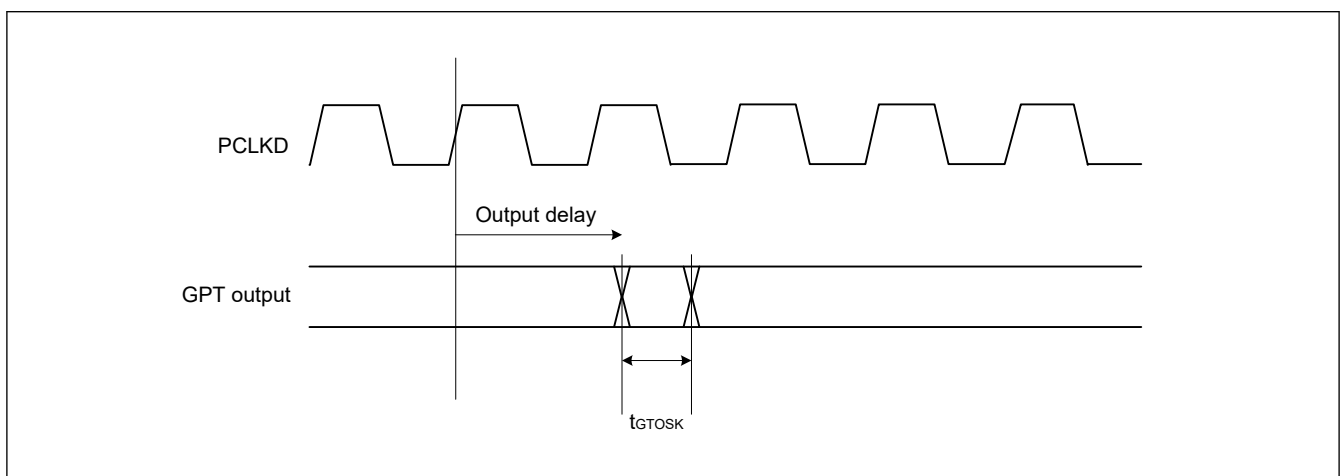

Figure 2.47 GPT output delay skew for OPS

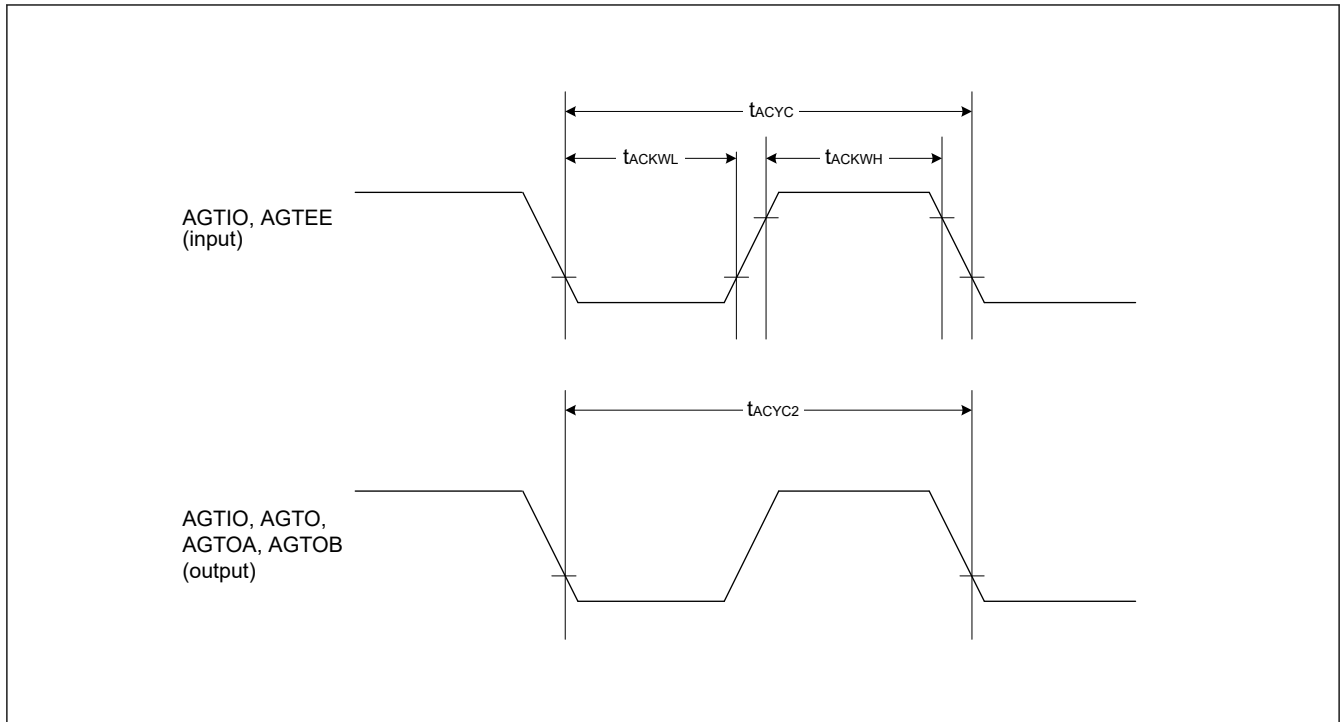

Figure 2.48 AGT input/output timing

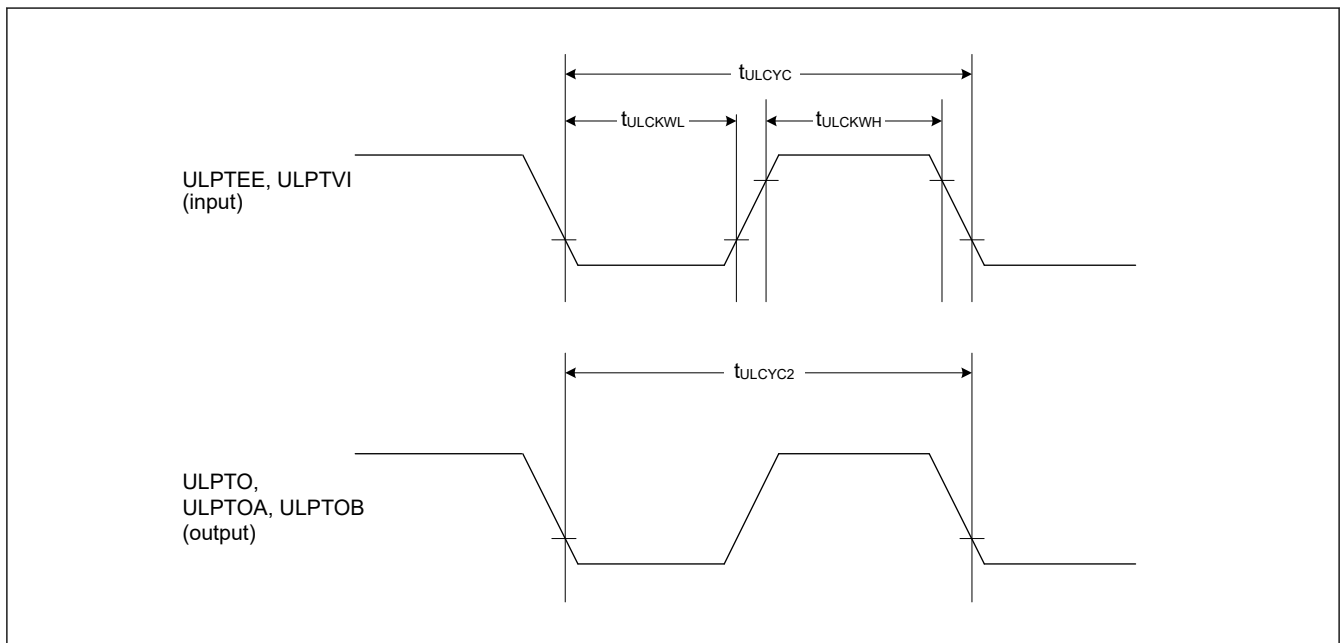

Figure 2.49 ULPT input/output timing

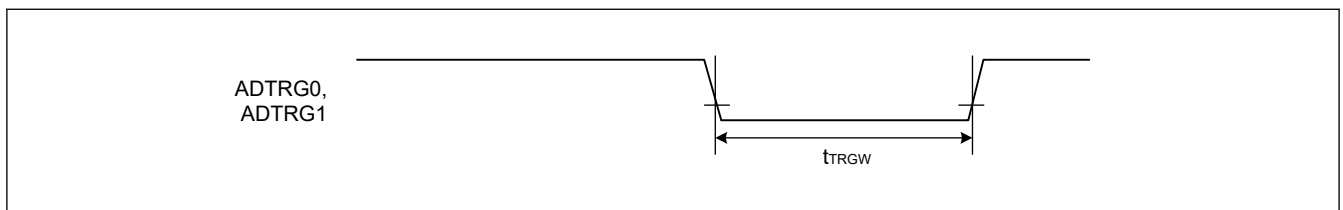

Figure 2.50 ADC12 trigger input timing

2.3.8 CAC Timing

Table 2.39 CAC timing

Parameter		Symbol	Min	Typ	Max	Unit	Test conditions
CAC	CACREF input pulse width	t_{PBcyc}	$t_{PBcyc} \leq t_{cac}^{*1}$	—	—	ns	—
			$t_{PBcyc} > t_{cac}^{*1}$	$4.5 \times t_{cac} + 3 \times t_{PBcyc}$	—	—	

Note: t_{PBcyc} : PCLKB cycle.

Note 1. t_{cac} : CAC count clock source cycle.

2.3.9 SCI Timing

Table 2.40 SCI timing (Asynchronous mode)

Conditions: High drive output is selected in the Port Drive Capability bit in the PmnPFS register.

If SCI pins are specified across the VCC I/O and VCC2 I/O, characteristics below is guaranteed only when VCC = VCC2.

Parameter	VCC/VCC2	Symbol	Min	Max	Unit	Note
Input clock cycle	1.68 V or above (VCC) 1.65 V or above (VCC2)	t_{Scyc}	4.0	—	t_{Tcyc}	Figure 2.51
Input clock pulse width	1.68 V or above (VCC) 1.65 V or above (VCC2)	t_{Sckw}	0.4	—	t_{Scyc}	
Input clock rise time	1.68 V or above (VCC) 1.65 V or above (VCC2)	t_{Sckr}	—	0.1 ^{*1}	t_{Scyc}	
Input clock fall time	1.68 V or above (VCC) 1.65 V or above (VCC2)	t_{Sckf}	—	0.1 ^{*1}	t_{Scyc}	
Output clock cycle	1.68 V or above (VCC) 1.65 V or above (VCC2)	t_{Scyc}	6.0	—	t_{Tcyc}	
Output clock pulse width	1.68 V or above (VCC) 1.65 V or above (VCC2)	t_{Sckw}	0.4	—	t_{Scyc}	
Output clock rise time	2.70 V or above	t_{Sckr}	—	3.3	ns	
	1.68 V or above (VCC) 1.65 V or above (VCC2)		—	6.6		
Output clock fall time	2.70 V or above	t_{Sckf}	—	3.3	ns	
	1.68 V or above (VCC) 1.65 V or above (VCC2)		—	6.6		

Note: t_{Tcyc} : TCLK cycle.

Note 1. 1 μ s at the longest

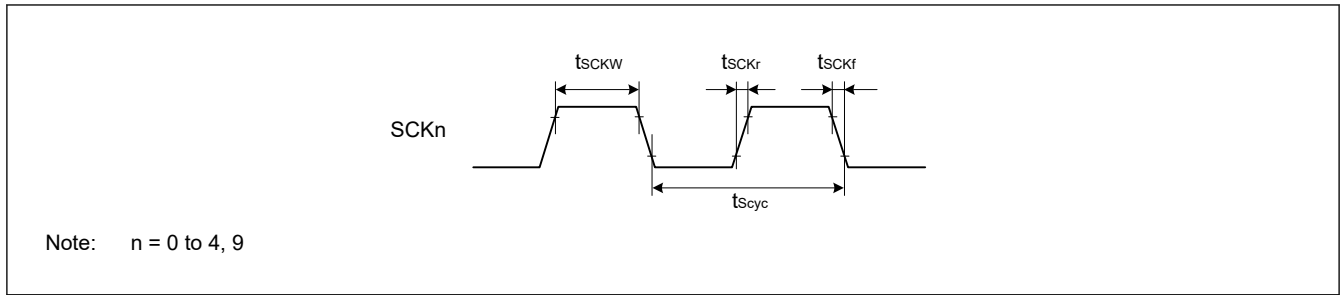

Figure 2.51 SCK clock input/output timing

Table 2.41 SCI timing (Simple SPI) (1 of 3)

Conditions: High drive output is selected in the Port Drive Capability bit in the PmnPFS register.

If SCI pins are specified across the VCC I/O and VCC2 I/O, characteristics below is guaranteed only when VCC = VCC2.

Parameter		High Speed/ Default	VCC/VCC2	Symbol	Min	Max	Unit	Note
SCK clock cycle output	Master	—	2.70 V or above	t_{SPcyc}	2.0	65536	t_{Tcyc}	Figure 2.52
			1.68 V or above (VCC) 1.65 V or above (VCC2)		4.0	65536		
SCK clock cycle input	Slave	—	2.70 V or above	t_{SPcyc}	2.0	65536	t_{Tcyc}	
			1.68 V or above (VCC) 1.65 V or above (VCC2)		4.0	65536		
SCK clock high pulse width	Master	—	1.68 V or above (VCC) 1.65 V or above (VCC2)	t_{SPCKWH}	0.4	—	t_{SPcyc}	
	Slave	—						
SCK clock low pulse width	Master	—	1.68 V or above (VCC) 1.65 V or above (VCC2)	t_{SPCKWL}	0.4	—	t_{SPcyc}	
	Slave	—						
SCK clock rise and fall time	Output	—	2.70 V or above	t_{SPCKr} , t_{SPCKf}	—	3.3	ns	
			1.68 V or above (VCC) 1.65 V or above (VCC2)		—	6.6		
	Input	—	2.70 V or above	t_{SPcyc}	—	0.1^{*3}		
			1.68 V or above (VCC) 1.65 V or above (VCC2)		—	0.1^{*3}		
Data input setup time	Master	High Speed ^{*1}	2.70 V or above	t_{SU}	14.9 - (AST[2:0] settings)	—	ns	Figure 2.53, Figure 2.54
			1.68 V or above (VCC) 1.65 V or above (VCC2)		23.1 - (AST[2:0] settings)	—		
		Default ^{*2}	2.70 V or above		16.2 - (AST[2:0] settings)	—		
			1.68 V or above (VCC) 1.65 V or above (VCC2)		23.8 - (AST[2:0] settings)	—		
	Slave	Default ^{*2}	2.70 V or above	2.5	—			
			1.68 V or above (VCC) 1.65 V or above (VCC2)	4.5	—			

Table 2.41 SCI timing (Simple SPI) (2 of 3)

Conditions: High drive output is selected in the Port Drive Capability bit in the PmnPFS register.

If SCI pins are specified across the VCC I/O and VCC2 I/O, characteristics below is guaranteed only when VCC = VCC2.

Parameter	High Speed/Default	VCC/VCC2	Symbol	Min	Max	Unit	Note		
Data input hold time	Master	High Speed* ¹	2.70 V or above	t_H	-3.2 + (AST[2:0] settings)	—	ns	Figure 2.53, Figure 2.54	
			1.68 V or above (VCC) 1.65 V or above (VCC2)		-3.2 + (AST[2:0] settings)	—			
		Default* ²	2.70 V or above		-3.2 + (AST[2:0] settings)	—			
			1.68 V or above (VCC) 1.65 V or above (VCC2)		-3.2 + (AST[2:0] settings)	—			
	Slave	Default* ²	2.70 V or above		2.5	—			
			1.68 V or above (VCC) 1.65 V or above (VCC2)		4.5	—			
Data output delay	Master	High Speed* ¹	2.70 V or above	t_{OD}	—	3.0	ns	Figure 2.53, Figure 2.54	
			1.68 V or above (VCC) 1.65 V or above (VCC2)		—	4.5			
		Default* ²	2.70 V or above		—	3.5			
			1.68 V or above (VCC) 1.65 V or above (VCC2)		—	5.5			
	Slave	High Speed* ¹	2.70 V or above		—	15.0			
			1.68 V or above (VCC) 1.65 V or above (VCC2)		—	23.0			
		Default* ²	2.70 V or above		—	21.0			
			1.68 V or above (VCC) 1.65 V or above (VCC2)		—	29.0			
Data output hold time	Master	High Speed* ¹	2.70 V or above	t_{OH}	-3.0	—	ns	Figure 2.53, Figure 2.54	
			1.68 V or above (VCC) 1.65 V or above (VCC2)		-4.5	—			
		Default* ²	2.70 V or above		-3.5	—			
			1.68 V or above (VCC) 1.65 V or above (VCC2)		-5.5	—			
	Slave	Default* ²	2.70 V or above		0.0	—			
			1.68 V or above (VCC) 1.65 V or above (VCC2)		0.0	—			
Data rise and fall time	Output	—	2.70 V or above	t_{Dr}, t_{Df}	—	3.3	ns		
			1.68 V or above (VCC) 1.65 V or above (VCC2)		—	6.6			
	Input	—	2.70 V or above		—	1.0			μs
			1.68 V or above (VCC) 1.65 V or above (VCC2)		—	1.0			
SS input setup time	—	1.68 V or above (VCC) 1.65 V or above (VCC2)	t_{LEAD}	1.0	—	t_{SPcyc}	Figure 2.55, Figure 2.56		
SS input hold time	—	1.68 V or above (VCC) 1.65 V or above (VCC2)	t_{LAG}	1.0	—	t_{SPcyc}			
SS input rise and fall time	—	1.68 V or above (VCC) 1.65 V or above (VCC2)	t_{SSLr}, t_{SSLf}	—	1.0	μs	—		

Table 2.41 SCI timing (Simple SPI) (3 of 3)

Conditions: High drive output is selected in the Port Drive Capability bit in the PmnPFS register.

If SCI pins are specified across the VCC I/O and VCC2 I/O, characteristics below is guaranteed only when VCC = VCC2.

Parameter	High Speed/ Default	VCC/VCC2	Symbol	Min	Max	Unit	Note
Slave access time	—	2.70 V or above	t_{SA}	—	$3 \times t_{Tcyc} + 25$	ns	Figure 2.55, Figure 2.56
		1.68 V or above (VCC) 1.65 V or above (VCC2)		—	$3 \times t_{Tcyc} + 32$		
Slave output release time	—	2.70 V or above	t_{REL}	—	$3 \times t_{Tcyc} + 25$	ns	
		1.68 V or above (VCC) 1.65 V or above (VCC2)		—	$3 \times t_{Tcyc} + 32$		

Note: t_{Tcyc} : TCLK cycle.

Note 1. Must use pins that have a letter appended to their name, for instance _A, _B, _C, to indicate group membership. SCI0, SCI1, SCI2, SCI3 and SCI9 are instance _A, SCI4 is instance _B.

Note 2. All pins of group membership can be used.

Note 3. 1 μ s at the longest

Table 2.42 SCI timing (Clock synchronous mode) (1 of 4)

Conditions: High drive output is selected in the Port Drive Capability bit in the PmnPFS register.

If SCI pins are specified across the VCC I/O and VCC2 I/O, characteristics below is guaranteed only when VCC = VCC2.

Parameter	High Speed/ Default	VCC/VCC2	Symbol	Min	Max	Unit	Note
SCK clock cycle output	Master	—	t_{Scyc}	2.0	—	t_{Tcyc}	
		1.68 V or above (VCC) 1.65 V or above (VCC2)		4.0	—		
SCK clock cycle input	Slave	—	t_{Scyc}	2.0	—	t_{Tcyc}	
		1.68 V or above (VCC) 1.65 V or above (VCC2)		4.0	—		
SCK clock high pulse width	Master	—	t_{SCKWH}	0.4	—	t_{Scyc}	
	Slave	1.68 V or above (VCC) 1.65 V or above (VCC2)					
SCK clock low pulse width	Master	—	t_{SCKWL}	0.4	—	t_{Scyc}	
	Slave	1.68 V or above (VCC) 1.65 V or above (VCC2)					

Table 2.42 SCI timing (Clock synchronous mode) (2 of 4)

Conditions: High drive output is selected in the Port Drive Capability bit in the PmnPFS register.

If SCI pins are specified across the VCC I/O and VCC2 I/O, characteristics below is guaranteed only when VCC = VCC2.

Parameter		High Speed/Default	VCC/VCC2	Symbol	Min	Max	Unit	Note
SCK clock rise and fall time	Output	—	2.70 V or above	$t_{SCKr}, SCKf$	—	3.3	ns	
			1.68 V or above (VCC) 1.65 V or above (VCC2)		—	6.6		
	Input	—	1.68 V or above (VCC) 1.65 V or above (VCC2)		—	0.1*3	t_{Scyc}	
Data input setup time	Master	High Speed*1	2.70 V or above	t_{SU}	15.1 - (AST[2:0] settings)	—	ns	
			1.68 V or above (VCC) 1.65 V or above (VCC2)		23.2 - (AST[2:0] settings)	—		
		Default*2	2.70 V or above		16.5 - (AST[2:0] settings)	—		
			1.68 V or above (VCC) 1.65 V or above (VCC2)		24.2 - (AST[2:0] settings)	—		
	Slave	Default*2	2.70 V or above	3.3	—			
			1.68 V or above (VCC) 1.65 V or above (VCC2)	5.3	—			
Data input hold time	Master	High Speed*1	2.70 V or above	t_H	-3.3 + (AST[2:0] settings)	—	ns	
			1.68 V or above (VCC) 1.65 V or above (VCC2)		-3.3 + (AST[2:0] settings)	—		
		Default*2	2.70 V or above		-3.2 + (AST[2:0] settings)	—		
			1.68 V or above (VCC) 1.65 V or above (VCC2)		-3.2 + (AST[2:0] settings)	—		
	Slave	Default*2	2.70 V or above	3.0	—			
			1.68 V or above (VCC) 1.65 V or above (VCC2)	5.0	—			

Table 2.42 SCI timing (Clock synchronous mode) (3 of 4)

Conditions: High drive output is selected in the Port Drive Capability bit in the PmnPFS register.

If SCI pins are specified across the VCC I/O and VCC2 I/O, characteristics below is guaranteed only when VCC = VCC2.

Parameter		High Speed/Default	VCC/VCC2	Symbol	Min	Max	Unit	Note
Data output delay	Master	High Speed*1	2.70 V or above	t_{OD}	—	5.0	ns	
			1.68 V or above (VCC) 1.65 V or above (VCC2)		—	5.0		
		Default*2	2.70 V or above		—	7.3		
			1.68 V or above (VCC) 1.65 V or above (VCC2)		—	7.3		
	Slave	High Speed*1	2.70 V or above		—	15.0		
			1.68 V or above (VCC) 1.65 V or above (VCC2)		—	23.0		
		Default*2	2.70 V or above		—	21.0		
			1.68 V or above (VCC) 1.65 V or above (VCC2)		—	29.0		
Data output hold time	Master	High Speed*1	2.70 V or above	t_{OH}	-5.0	—	ns	
			1.68 V or above (VCC) 1.65 V or above (VCC2)		-5.0	—		
		Default*2	2.70 V or above		-7.3	—		
			1.68 V or above (VCC) 1.65 V or above (VCC2)		-7.3	—		
	Slave	High Speed*1	2.70 V or above		0	—		
			1.68 V or above (VCC) 1.65 V or above (VCC2)		0	—		
		Default*2	2.70 V or above		0	—		
			1.68 V or above (VCC) 1.65 V or above (VCC2)		0	—		

Table 2.42 SCI timing (Clock synchronous mode) (4 of 4)

Conditions: High drive output is selected in the Port Drive Capability bit in the PmnPFS register.
 If SCI pins are specified across the VCC I/O and VCC2 I/O, characteristics below is guaranteed only when VCC = VCC2.

Parameter	High Speed/Default	VCC/VCC2	Symbol	Min	Max	Unit	Note
Data rise and fall time	Output	—	t_{Dr}, t_{Df}	—	3.3	ns	
		—		1.68 V or above (VCC) 1.65 V or above (VCC2)	—		
	Input	—		1.68 V or above (VCC) 1.65 V or above (VCC2)	—	1.0	

Note: t_{Tcyc} : TCLK cycle.

Note 1. Must use pins that have a letter appended to their name, for instance _A, _B, _C, to indicate group membership. SCI0, SCI1, SCI2, SCI3 and SCI9 are instance _A, SCI4 is instance _B.

Note 2. All pins of group membership can be used.

Note 3. 1 μ s at the longest

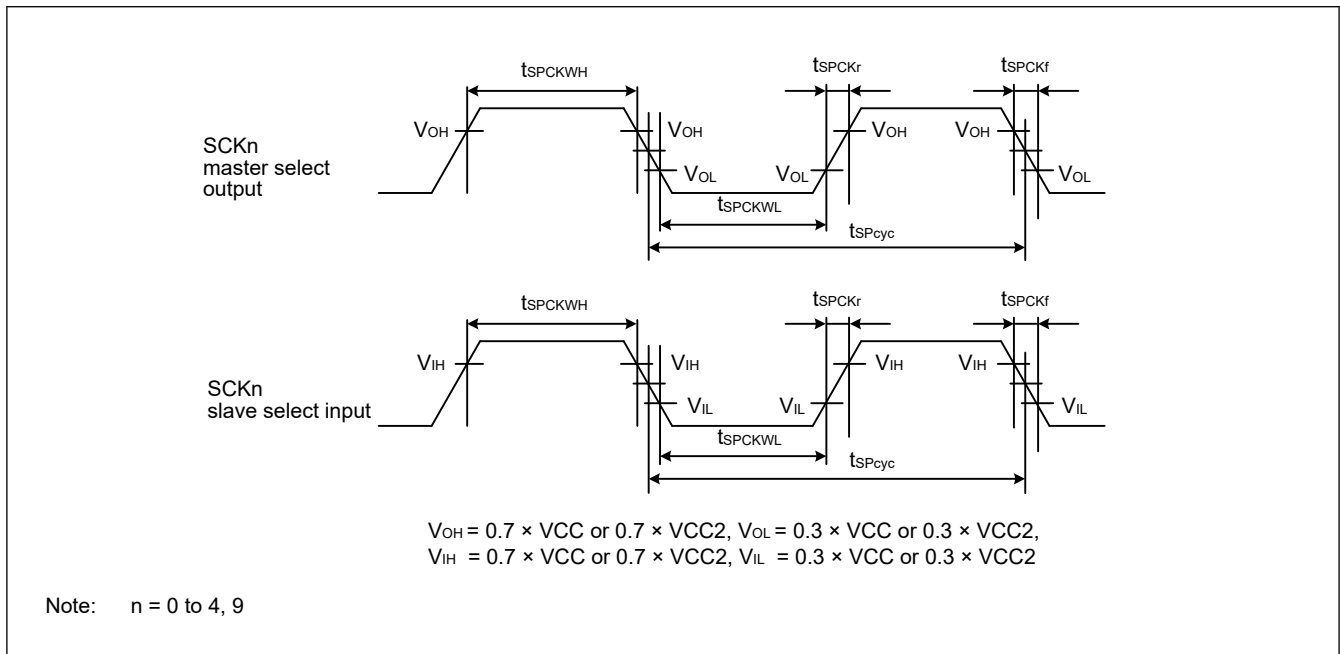

Figure 2.52 SCI simple SPI mode clock timing

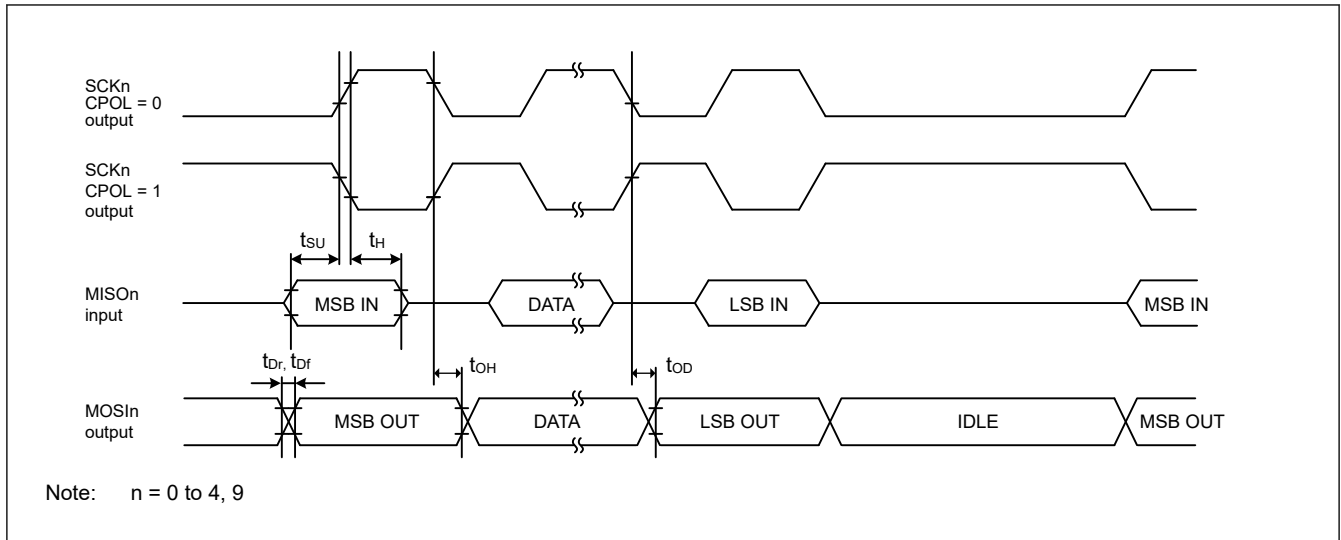

Figure 2.53 SCI simple SPI mode timing for master when CPHA = 0

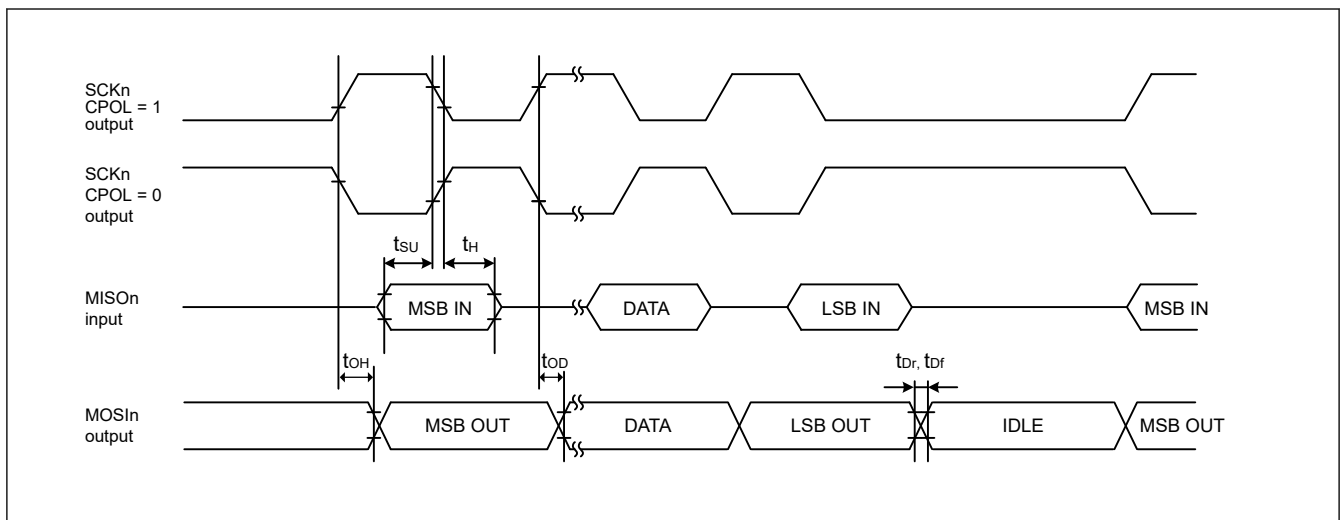

Figure 2.54 SCI simple SPI mode timing for master when CPHA = 1

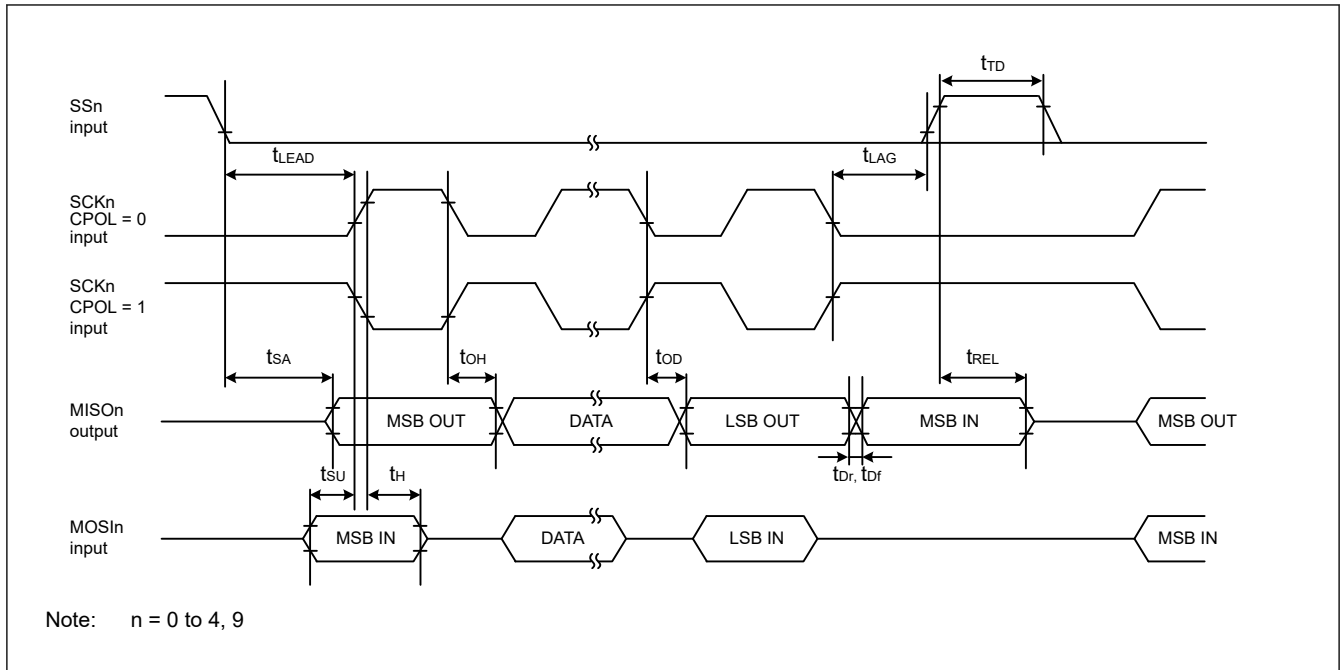

Figure 2.55 SCI simple SPI mode timing for slave when CPHA = 0

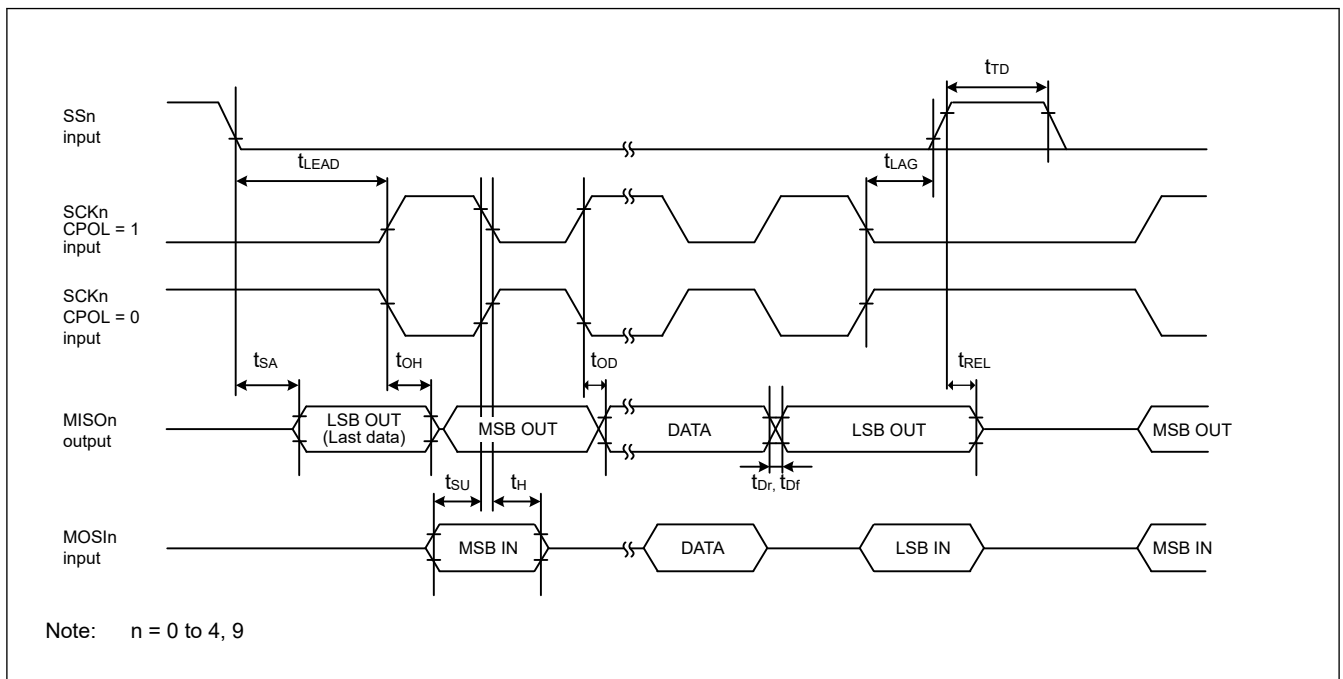

Figure 2.56 SCI simple SPI mode timing for slave when CPHA = 1

Table 2.43 SCI timing (Simple IIC mode)

Conditions: Middle drive output is selected in the Port Drive Capability bit in the PmnPFS register.
 VCC: 1.68V or above, VCC2: 1.65V or above

If SCI pins are specified across the VCC I/O and VCC2 I/O, characteristics below is guaranteed only when VCC = VCC2.

Parameter	Symbol	Min	Max	Unit	Note
Simple IIC (Standard mode)	SCL, SDA input rise time	t_{sr}	—	1000	ns
	SCL, SDA input fall time	t_{sf}	—	300	ns
	SCL, SDA input spike pulse removal time	t_{sp}	0	$4 \times t_{Tcyc}$	ns
	Data input setup time	t_{SDAS}	250	—	ns
	Data input hold time	t_{SDAH}	0	—	ns
	SCL, SDA capacitive load	C_b^{*1}	—	400	pF
Simple IIC (Fast mode)	SCL, SDA input rise time	t_{sr}	—	300	ns
	SCL, SDA input fall time	t_{sf}	—	300	ns
	SCL, SDA input spike pulse removal time	t_{sp}	0	$4 \times t_{Tcyc}$	ns
	Data input setup time	t_{SDAS}	100	—	ns
	Data input hold time	t_{SDAH}	0	—	ns
	SCL, SDA capacitive load	C_b^{*1}	—	400	pF

Note: t_{Tcyc} : TCLK cycle.

Note 1. C_b indicates the total capacity of the bus line.

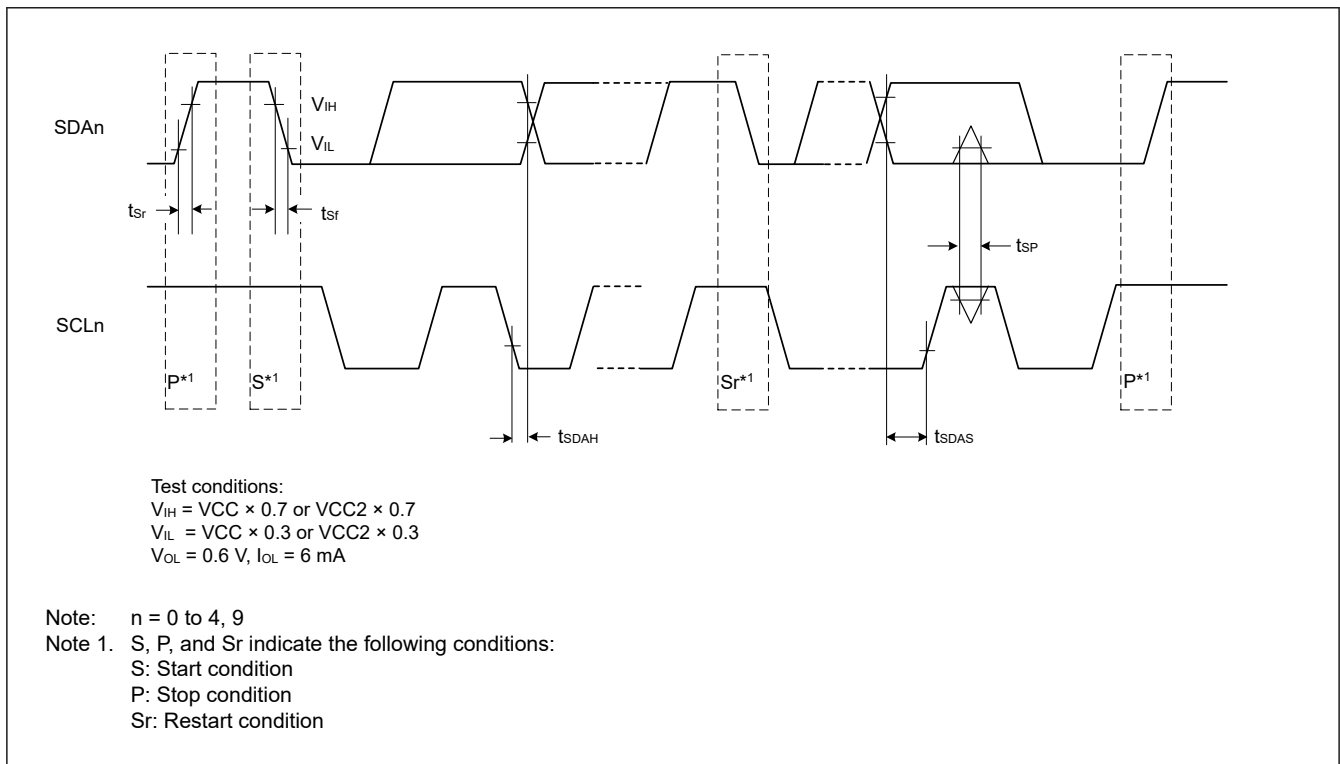

Figure 2.57 SCI simple IIC mode timing

2.3.10 SPI Timing

Table 2.44 SPI timing (1 of 4)

Conditions:

1. High drive output is selected in the Port Drive Capability bit in the PmnPFS register.
2. Use pins that have a letter appended to their names, for instance “_A” or “_B” to indicate group membership.
3. Load capacitance C = 15pF is applied to the VCC/VCC2 condition “3.00 V or above”.

Parameter		VCC/VCC2	Symbol	Min	Max	Unit	Note
RSPCK clock cycle	Master	3.00 V or above	t_{SPCyc}	2.0	4096	t_{Tcyc}	Figure 2.58
		2.70 V or above		2.0	4096		
		1.68 V or above (VCC) 1.65 V or above (VCC2)		4.0	4096		
	Slave	3.00 V or above		2.0	—		
		2.70 V or above		2.0	—		
		1.68 V or above (VCC) 1.65 V or above (VCC2)		4.0	—		
RSPCK clock high pulse width	Master	1.68 V or above (VCC) 1.65 V or above (VCC2)	t_{SPCKWH}	$(t_{SPCyc} - t_{SPCKr} - t_{SPCKf}) / 2 - 3$		ns	
	Slave	1.68 V or above (VCC) 1.65 V or above (VCC2)		0.4	—	t_{SPCyc}	
RSPCK clock low pulse width	Master	1.68 V or above (VCC) 1.65 V or above (VCC2)	t_{SPCKWL}	$(t_{SPCyc} - t_{SPCKr} - t_{SPCKf}) / 2 - 3$		ns	
	Slave	1.68 V or above (VCC) 1.65 V or above (VCC2)		0.4	—	t_{SPCyc}	
RSPCK clock rise and fall time	Output	3.00 V or above	t_{SPCKr}, t_{SPCKf}	—	1.66	ns	
		2.70 V or above		—	3.30		
		1.68 V or above (VCC) 1.65 V or above (VCC2)		—	6.60		
	Input	3.00 V or above		—	0.1*1	t_{SPCyc}	
		2.70 V or above		—	0.1*1		
		1.68 V or above (VCC) 1.65 V or above (VCC2)		—	0.1*1		

Table 2.44 SPI timing (2 of 4)

Conditions:

1. High drive output is selected in the Port Drive Capability bit in the PmnPFS register.
2. Use pins that have a letter appended to their names, for instance “_A” or “_B” to indicate group membership.
3. Load capacitance C = 15pF is applied to the VCC/VCC2 condition "3.00 V or above".

Parameter		VCC/VCC2	Symbol	Min	Max	Unit	Note
Data input setup time	Master	3.00 V or above	t_{SU}	-2.5	—	ns	Figure 2.59, Figure 2.60
		2.70 V or above		0.0	—		
		1.68 V or above (VCC) 1.65 V or above (VCC2)		0.0	—		
	Slave	3.00 V or above		2.5	—		
		2.70 V or above		2.5	—		
		1.68 V or above (VCC) 1.65 V or above (VCC2)		2.5	—		
Data input hold time	Master	3.00 V or above	t_H	7.5	—	ns	
		2.70 V or above		7.5	—		
		1.68 V or above (VCC) 1.65 V or above (VCC2)		9.5	—		
	Slave	3.00 V or above		2.5	—		
		2.70 V or above		2.5	—		
		1.68 V or above (VCC) 1.65 V or above (VCC2)		5.5	—		
SSL setup time	Master	3.00 V or above	t_{LEAD}	$1 \times t_{SPcyc} - 10$	$8 \times t_{SPcyc} + 10$	ns	
		2.70 V or above		$1 \times t_{SPcyc} - 10$	$8 \times t_{SPcyc} + 10$		
		1.68 V or above (VCC) 1.65 V or above (VCC2)		$1 \times t_{SPcyc} - 10$	$8 \times t_{SPcyc} + 10$		
	Slave	3.00 V or above		4.0	—	t_{Tcyc}	
		2.70 V or above		4.0	—		
		1.68 V or above (VCC) 1.65 V or above (VCC2)		4.0	—		
SSL hold time	Master	3.00 V or above	t_{LAG}	$1 \times t_{SPcyc} - 10$	$8 \times t_{SPcyc} + 10$	ns	
		2.70 V or above		$1 \times t_{SPcyc} - 10$	$8 \times t_{SPcyc} + 10$		
		1.68 V or above (VCC) 1.65 V or above (VCC2)		$1 \times t_{SPcyc} - 10$	$8 \times t_{SPcyc} + 10$		
	Slave	3.00 V or above		4.0	—	t_{Tcyc}	
		2.70 V or above		4.0	—		
		1.68 V or above (VCC) 1.65 V or above (VCC2)		4.0	—		

Table 2.44 SPI timing (3 of 4)

Conditions:

- High drive output is selected in the Port Drive Capability bit in the PmnPFS register.
- Use pins that have a letter appended to their names, for instance “_A” or “_B” to indicate group membership.
- Load capacitance C = 15pF is applied to the VCC/VCC2 condition “3.00 V or above”.

Parameter	VCC/VCC2	Symbol	Min	Max	Unit	Note		
TI SSP SS input setup time	Slave	3.00 V or above	t_{TISS}	2.5	—	ns	Figure 2.64	
				2.70 V or above	2.5			—
				1.68 V or above (VCC) 1.65 V or above (VCC2)	2.5			—
TI SSP SS input hold time	Slave	3.00 V or above	t_{TISH}	2.5	—	ns		
				2.70 V or above	2.5			—
				1.68 V or above (VCC) 1.65 V or above (VCC2)	5.5			—
TI SSP next-access time	Slave	3.00 V or above	t_{TIND}	$2 \times t_{TCyc} + SLNDL \times t_{TCyc}$	—	ns		
				2.70 V or above	$2 \times t_{TCyc} + SLNDL \times t_{TCyc}$			—
				1.68 V or above (VCC) 1.65 V or above (VCC2)	$2 \times t_{TCyc} + SLNDL \times t_{TCyc}$			—
TI SSP master SS output delay	Master	3.00 V or above	t_{TISSOD}	—	4.0	ns	Figure 2.61	
				2.70 V or above	—			8.0
				1.68 V or above (VCC) 1.65 V or above (VCC2)	—			8.0
Data output delay time	Master	3.00 V or above	t_{OD1}	—	2.0	ns	Figure 2.59, Figure 2.60	
				2.70 V or above	—			3.0
				1.68 V or above (VCC) 1.65 V or above (VCC2)	—			6.0
		3.00 V or above	t_{OD2}	—	2.5			
				2.70 V or above	—			2.5
				1.68 V or above (VCC) 1.65 V or above (VCC2)	—			4.5
	Slave	3.00 V or above	t_{OD}	—	12.5			
				2.70 V or above	—			16.0
				1.68 V or above (VCC) 1.65 V or above (VCC2)	—			24.0
Data output hold time	Master	3.00 V or above	t_{OH}	-2.5	—	ns	Figure 2.59, Figure 2.60	
				2.70 V or above	-2.5			—
				1.68 V or above (VCC) 1.65 V or above (VCC2)	-4.5			—
	Slave	3.00 V or above		0.0	—			
				2.70 V or above	0.0			—
				1.68 V or above (VCC) 1.65 V or above (VCC2)	0.0			—

Table 2.44 SPI timing (4 of 4)

Conditions:

1. High drive output is selected in the Port Drive Capability bit in the PmnPFS register.
2. Use pins that have a letter appended to their names, for instance “_A” or “_B” to indicate group membership.
3. Load capacitance C = 15pF is applied to the VCC/VCC2 condition “3.00 V or above”.

Parameter		VCC/VCC2	Symbol	Min	Max	Unit	Note
Successive transmission delay time	Master	3.00 V or above	t_{TD}	$t_{SPcyc} + 2 \times t_{TCyc}$	$8 \times t_{SPcyc} + 2 \times t_{TCyc}$	ns	Figure 2.59, Figure 2.60
		2.70 V or above		$t_{SPcyc} + 2 \times t_{TCyc}$	$8 \times t_{SPcyc} + 2 \times t_{TCyc}$		
		1.68 V or above (VCC) 1.65 V or above (VCC2)		$t_{SPcyc} + 2 \times t_{TCyc}$	$8 \times t_{SPcyc} + 2 \times t_{TCyc}$		
	Slave	3.00 V or above		t_{TCyc}	—	ns	
		2.70 V or above		t_{TCyc}	—		
		1.68 V or above (VCC) 1.65 V or above (VCC2)		t_{TCyc}	—		
MOSI and MISO rise and fall time	Output	3.00 V or above	t_{Dr}, t_{Df}	—	1.66	ns	Figure 2.59, Figure 2.60
		2.70 V or above		—	3.30		
		1.68 V or above (VCC) 1.65 V or above (VCC2)		—	6.60		
	Input	3.00 V or above		—	1.0	μs	
		2.70 V or above		—	1.0		
		1.68 V or above (VCC) 1.65 V or above (VCC2)		—	1.0		
SSL rise and fall time	Output	3.00- V or above	t_{SSLr}, t_{SSLf}	—	1.66	ns	Figure 2.59, Figure 2.60
		2.70 V or above		—	3.30		
		1.68 V or above (VCC) 1.65 V or above (VCC2)		—	6.60		
	Input	3.00 V or above		—	1.0	μs	
		2.70 V or above		—	1.0		
		1.68 V or above (VCC) 1.65 V or above (VCC2)		—	1.0		
Slave access time	Slave	3.00 V or above	t_{SA}	—	20.0	ns	Figure 2.62, Figure 2.63
		2.70 V or above		—	20.0		
		1.68 V or above (VCC) 1.65 V or above (VCC2)		—	25.0		
Slave output release time	Slave	3.00 V or above	t_{REL}	—	20.0	ns	
		2.70 V or above		—	20.0		
		1.68 V or above (VCC) 1.65 V or above (VCC2)		—	25.0		

Note 1. 1 μs at the longest

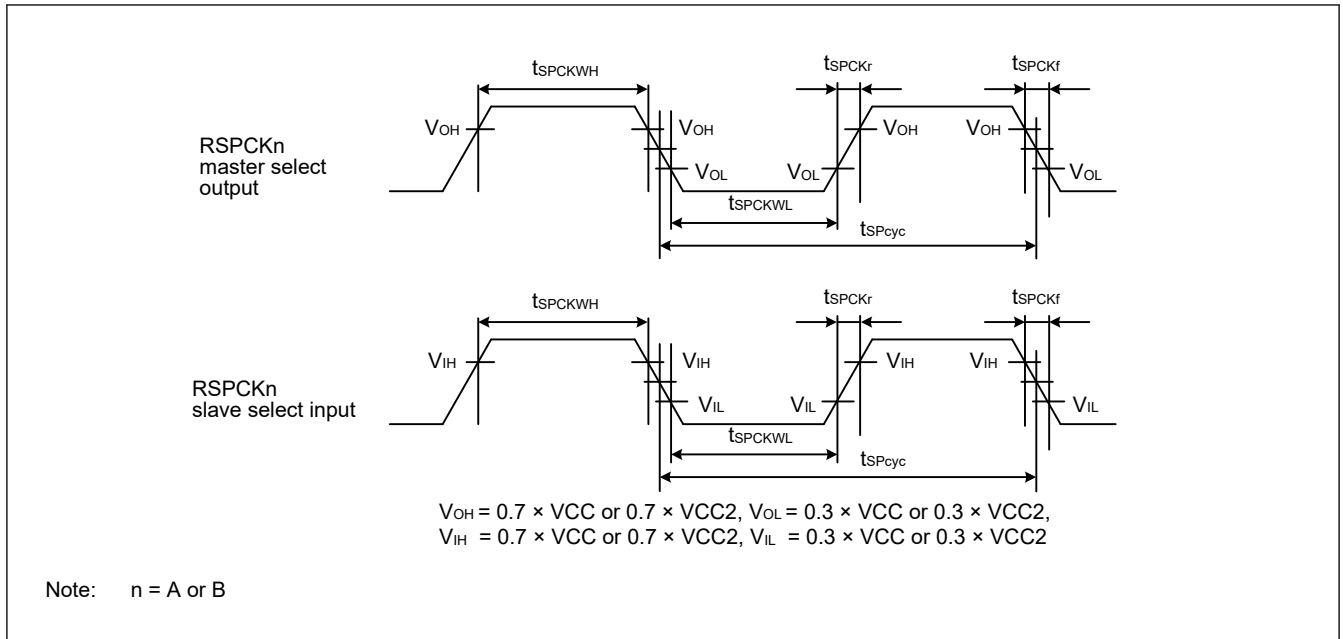

Figure 2.58 SPI clock timing

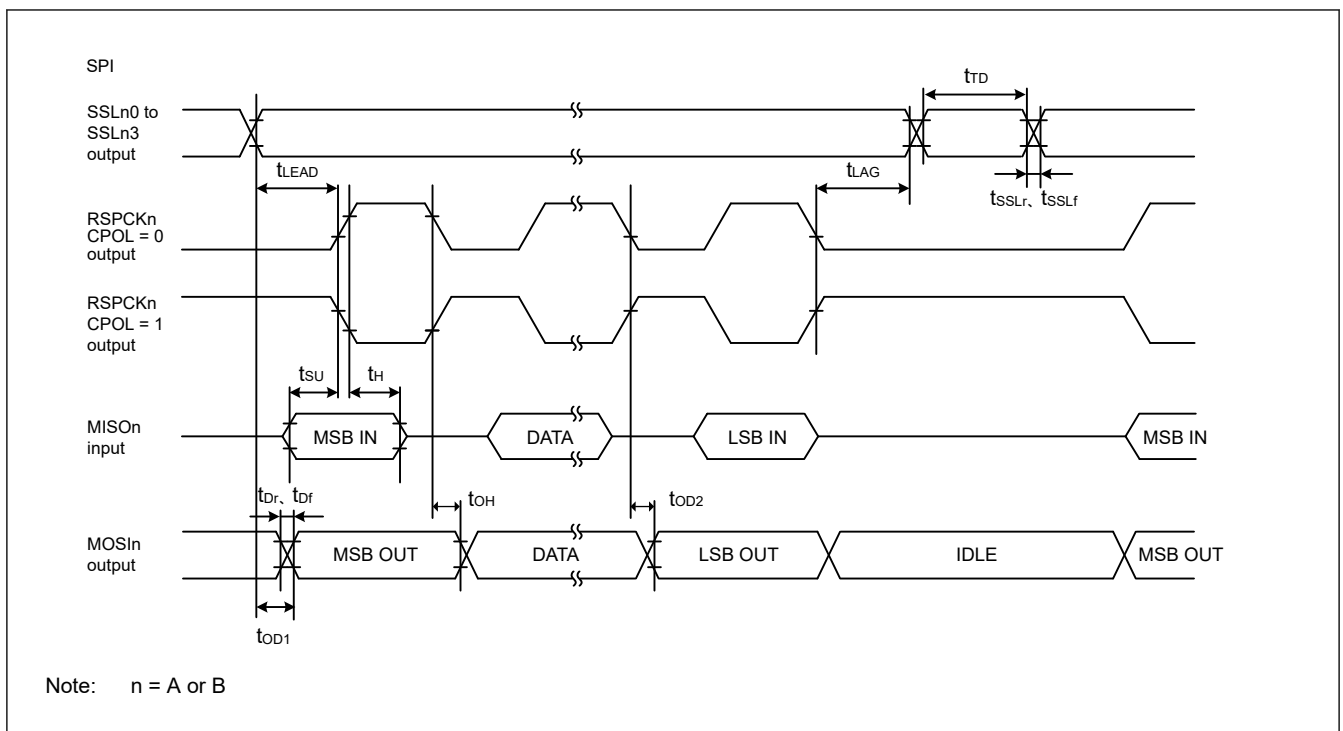

Figure 2.59 SPI timing for Motorola SPI master when CPHA = 0

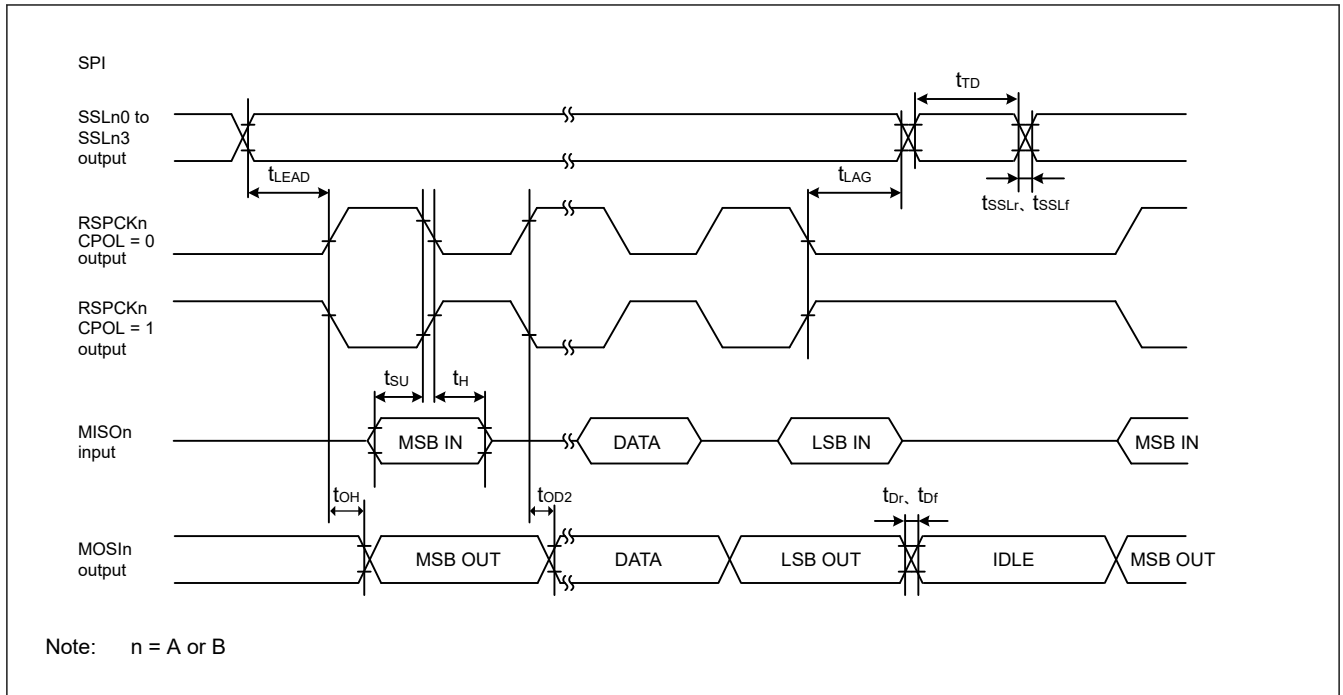

Figure 2.60 SPI timing for Motorola SPI master when CPHA = 1

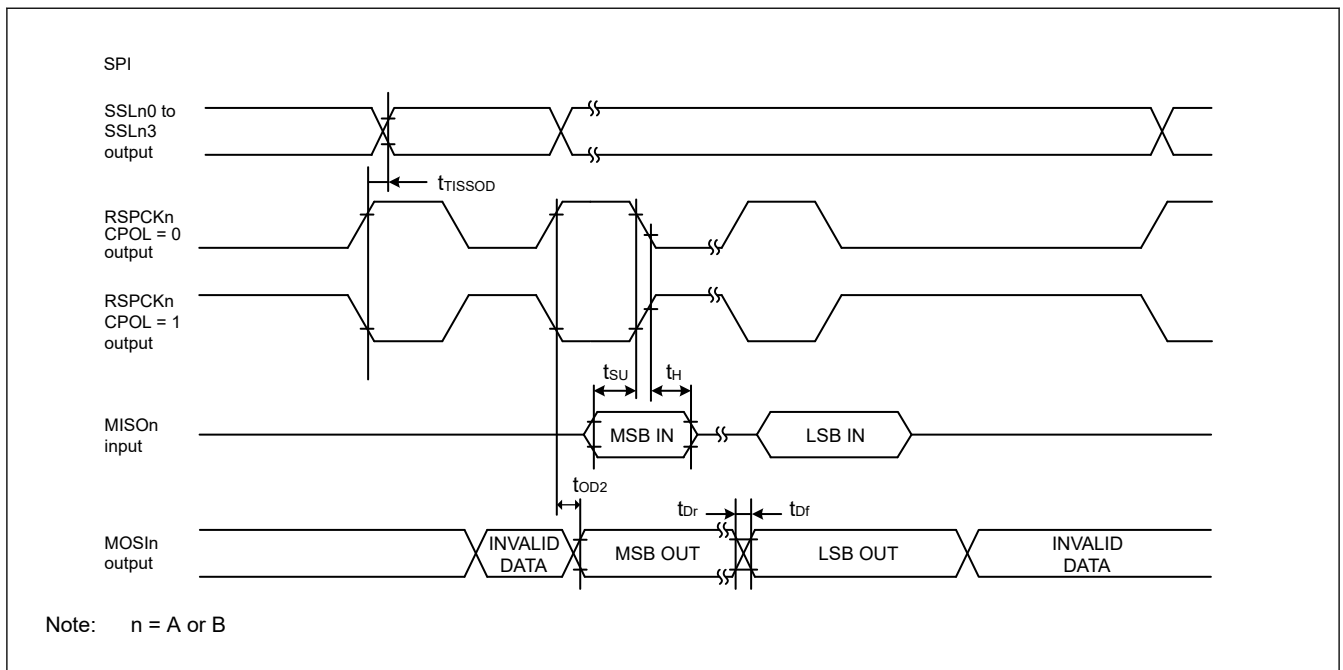

Figure 2.61 SPI timing for TI SSP master

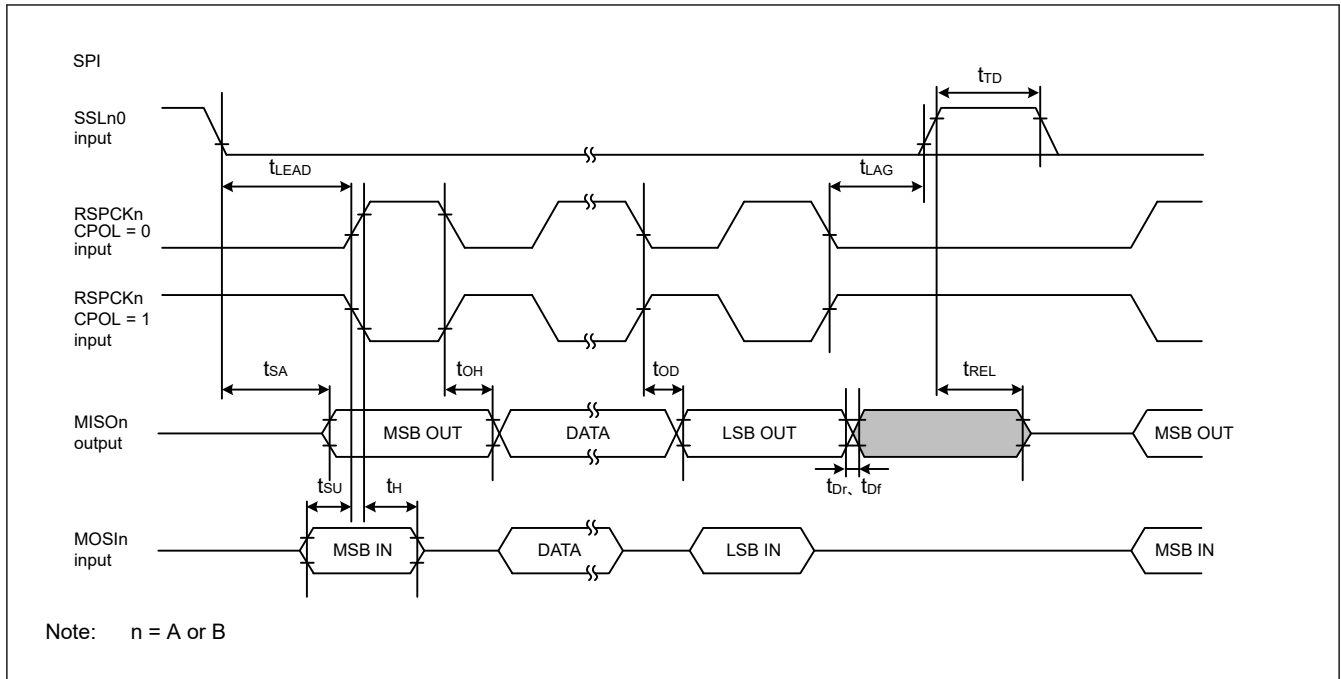

Figure 2.62 SPI timing for Motorola SPI slave when CPHA = 0

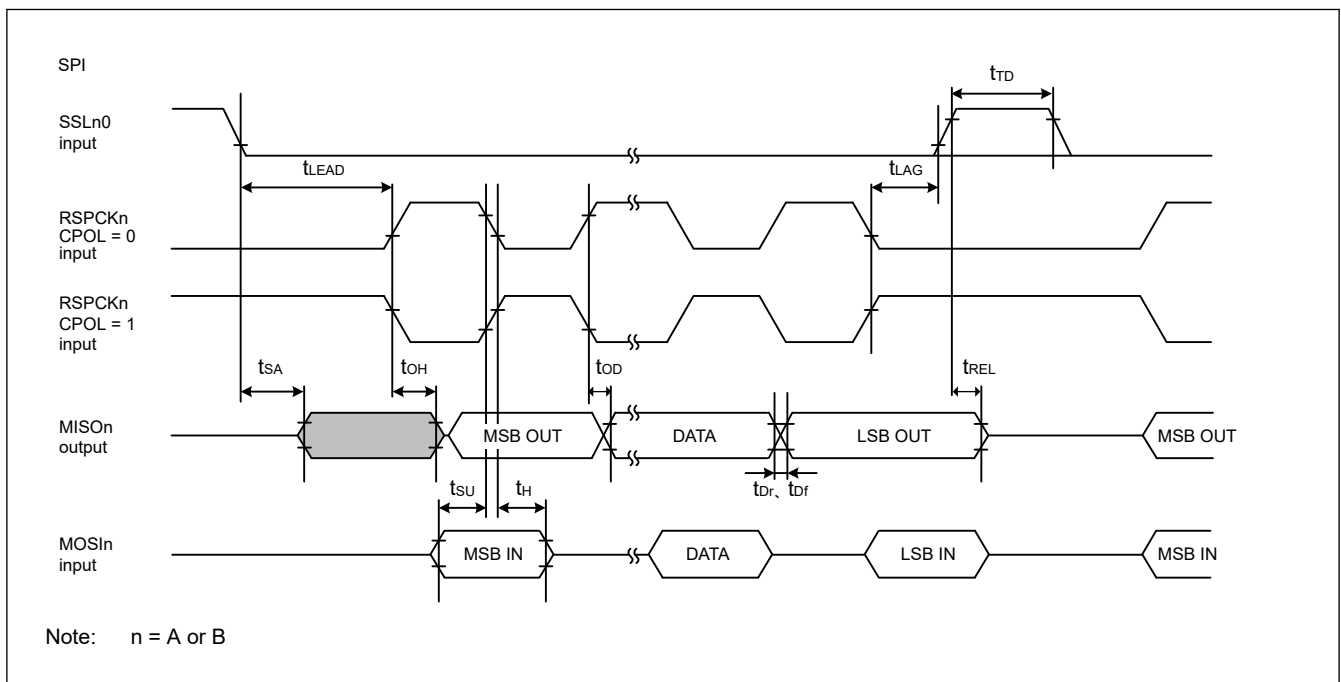

Figure 2.63 SPI timing for Motorola SPI slave when CPHA = 1

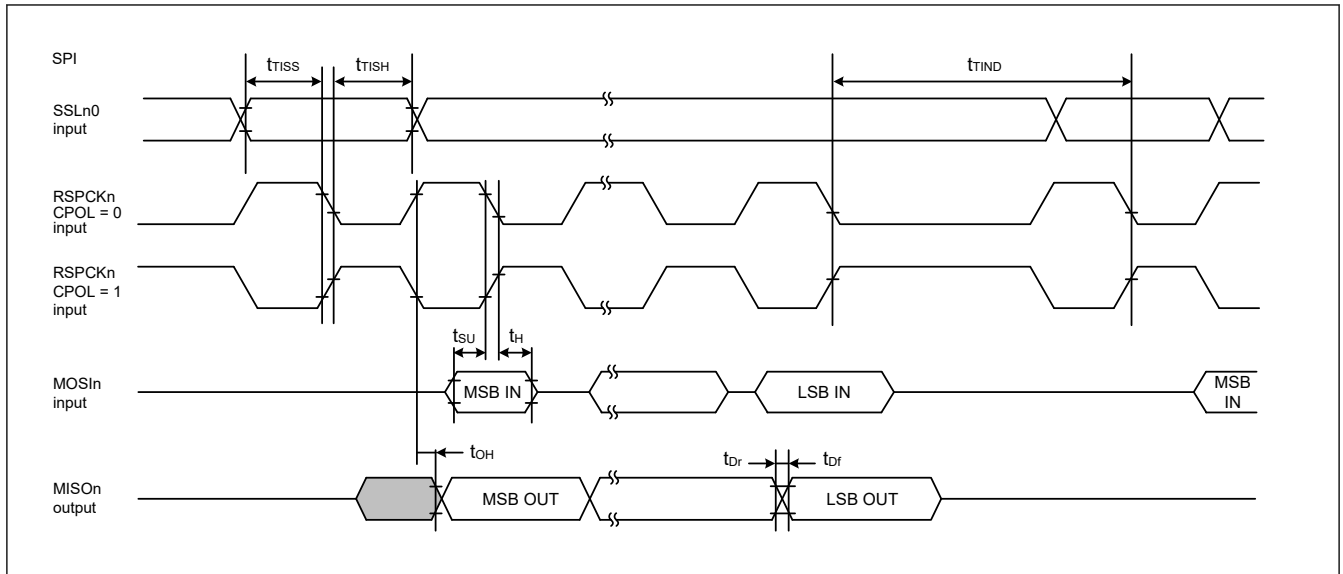

Figure 2.64 SPI timing for TI SSP slave when transmit with delay between frames

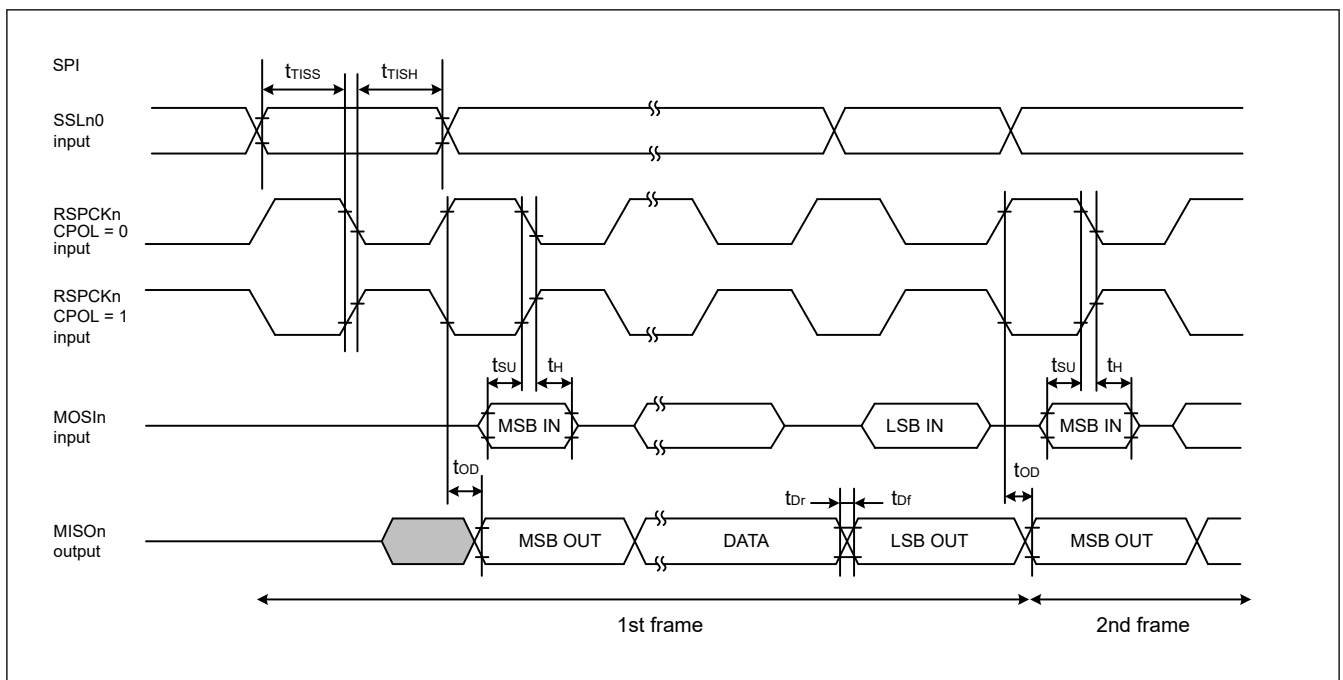

Figure 2.65 SPI timing for TI SSP slave when transmit with no delay between frames

2.3.11 OSPI Timing

Table 2.45 OSPI timing (1 of 2)

Conditions:

High-speed high drive output is selected in the port drive capability bit in the PmnPFS register for the following pins: OM_SCLK, OM_SCLKN, OM_SIO7-0, OM_DQS.

High drive output is selected in the port drive capability bit in the PmnPFS register for the following pins: OM_CS0, OM_CS1.

Load capacitance C = 20 pF

Item	Symbol	VCC/VCC2	Min	Max	Unit	Note
Cycle time	SDR without OM_DQS	2.70 V or above	20	—	ns	Figure 2.66
		1.65 V to 2.00 V	20	—		
	SDR with OM_DQS/DDR	2.70 V or above	10	—	ns	
		1.65 V to 2.00 V	10	—		
Clock output slew rate	t_{SRck}	2.70 V or above	0.56	—	V/ns	
		1.65 V to 2.00 V	0.56	—		
Clock Duty cycle-distortion	t_{CKDCD}	2.70 V or above	0	0.5	ns	
		1.65 V to 2.00 V	0	0.5		
Clock Minimum Pulse width	t_{CKMPW}	2.70 V or above	4.5	—	ns	
		1.65 V to 2.00 V	4.5	—		
Differential clock crossing volate	$V_{ox}(AC)$	2.70 V or above	$0.4 \times VCC2$	$0.6 \times VCC2$	V	
		1.65 V to 2.00 V	$0.4 \times VCC2$	$0.6 \times VCC2$		
DS Duty cycle distortion	t_{DSDCD}	2.70 V or above	0	0.4	ns	
		1.65 V to 2.00 V	0	0.4		
DS Minimum Pulse width	t_{DSMPW}	2.70 V or above	4.1	—	ns	
		1.65 V to 2.00 V	4.1	—		
Data input/output slew rate	t_{SR}	2.70 V or above	1.03	—	ns	
		1.65 V to 2.00 V	0.56	—		
Data input setup time (to OM_SCLK/ OM_SCLKN)	t_{SU}	2.70 V or above	8.0	—	ns	Figure 2.67
		1.65 V to 2.00 V	12.5	—		
Data input hold time (to OM_SCLK/ OM_SCLKN)	t_H	2.70 V or above	0.5	—	ns	
		1.65 V to 2.00 V	0.5	—		
Data output valid time	t_{OV}^{*2}	2.70 V or above	—	4.0	ns	
		1.65 V to 2.00 V	—	4.0		
Data output hold time	t_{OH}	2.70 V or above	-2.0	—	ns	
		1.65 V to 2.00 V	-2.0	—		
Data output buffer off time	t_{BOFF}	2.70 V or above	-2.0	—	ns	
		1.65 V to 2.00 V	-2.0	—		

Table 2.45 OSPI timing (2 of 2)

Conditions:

High-speed high drive output is selected in the port drive capability bit in the PmnPFS register for the following pins: OM_SCLK, OM_SCLKN, OM_SIO7-0, OM_DQS.

High drive output is selected in the port drive capability bit in the PmnPFS register for the following pins: OM_CS0, OM_CS1.

Load capacitance C = 20 pF

Item	Symbol	VCC/VCC2	Min	Max	Unit	Note	
Data input setup time (to OM_DQS)	t_{SU}	2.70 V or above	-0.9	—	ns	Figure 2.68, Figure 2.69	
		1.65 V to 2.00 V	-0.9	—			
Data input hold time (to OM_DQS)	t_H	2.70 V or above	3.2	—	ns		
		1.65 V to 2.00 V	3.2	—			
Data output valid time	t_{OV}^{*2}	2.70 V or above	—	$t_{PERIOD}/4 + 0.9$	ns		
		1.65 V to 2.00 V	—	$t_{PERIOD}/4 + 0.9$			
Data output hold time	t_{HO}	2.70 V or above	1.1	—	ns		
		1.65 V to 2.00 V	1.1	—			
Data output buffer off time	t_{BOFF}	2.70 V or above	1.1	—	ns		
		1.65 V to 2.00 V	1.1	—			
Clock Low to CS Low	t_{CKLCSL}	2.70 V or above	8	—	ns	Figure 2.67, Figure 2.68, Figure 2.69	
		1.65 V to 2.00 V	8	—			
CS Low to Clock High	t_{CSLCKH}^{*3}	2.70 V or above	8	—	ns		
		1.65 V to 2.00 V	8	—			
Clock Low to CS High	t_{CKLCSH}	2.70 V or above	8	—	ns		
		1.65 V to 2.00 V	8	—			
CS High to Clock High	t_{CSHCKH}	2.70 V or above	8	—	ns		
		1.65 V to 2.00 V	8	—			
DS Low output to CS High	t_{DSLCSH}	2.70 V or above	$0.8 \times t_{PERIOD}$	—	ns		Figure 2.70
		1.65 V to 2.00 V	$0.8 \times t_{PERIOD}$	—			
CS High to DS Tri-State	t_{CSHDST}	2.70 V or above	—	t_{PERIOD}	ns		
		1.65 V to 2.00V	—	t_{PERIOD}			
CS Low to DS Low input ^{*1}	t_{CSLDSL}	2.70 V or above	0	18.5	ns		
		1.65 V to 2.00 V	0	12.5			
DS Tri-State to CS Low	t_{DSTCSL}	2.70 V or above	0	—	ns		
		1.65 V to 2.00 V	0	—			

Note 1. This restriction does not need to be met when using the JESD251 Profile 1.0 memory with an external pull-down attached to the OM_DQS pin.

Note 2. Condition: COMCFG.OEASTEX = 1

Note 3. Condition: LIOCFGCSx.CSASTEX = 1

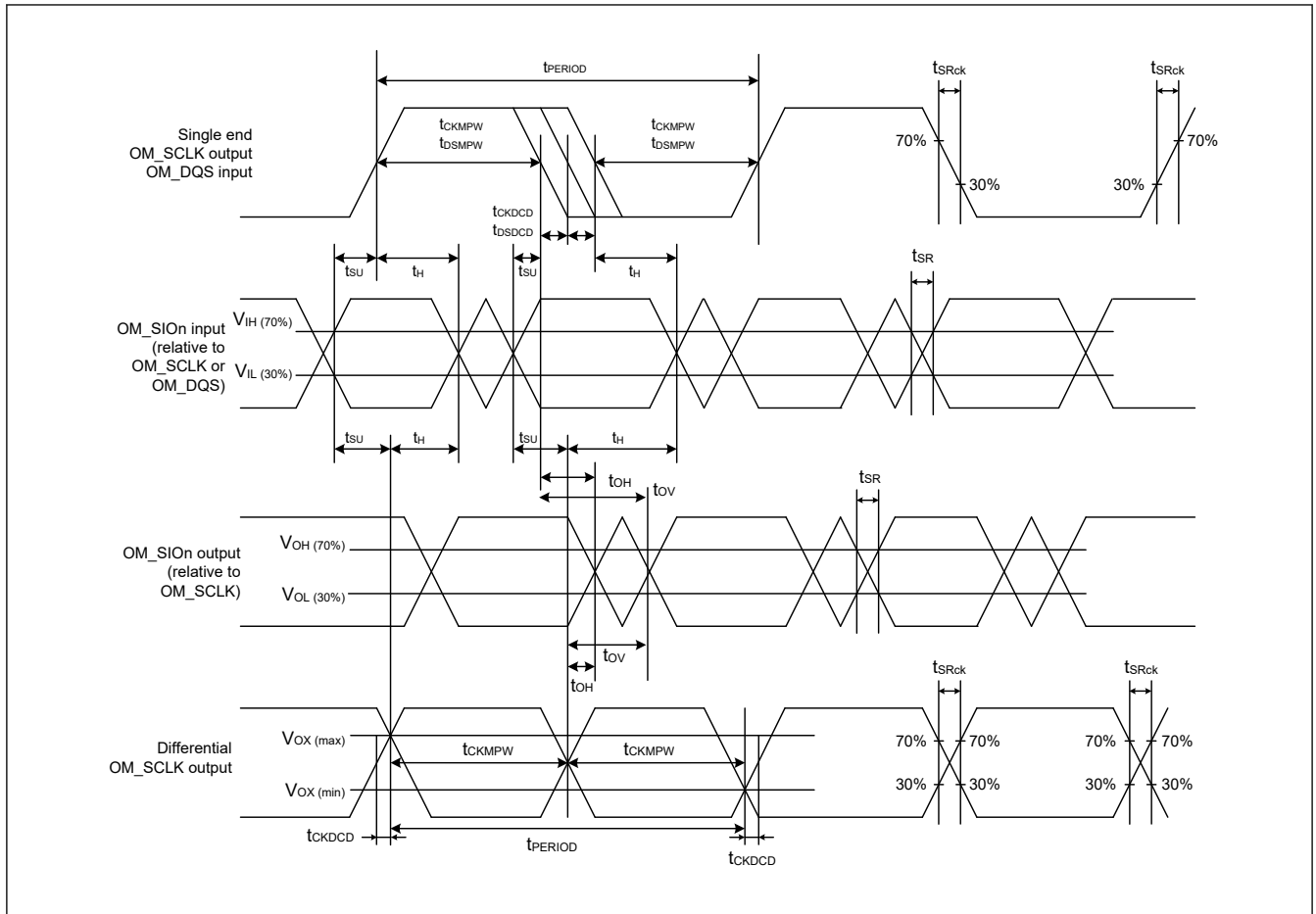

Figure 2.66 OSPI clock / DS timing

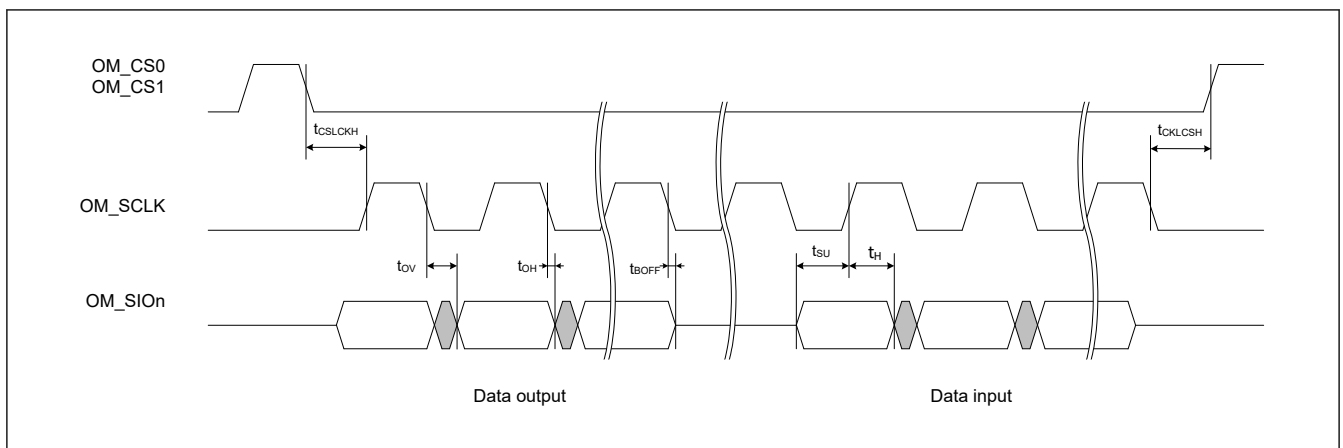

Figure 2.67 SDR transmit/receive timing (1S-1S-1S, 1S-2S-2S, 2S-2S-2S, 1S-4S-4S, 4S-4S-4S)

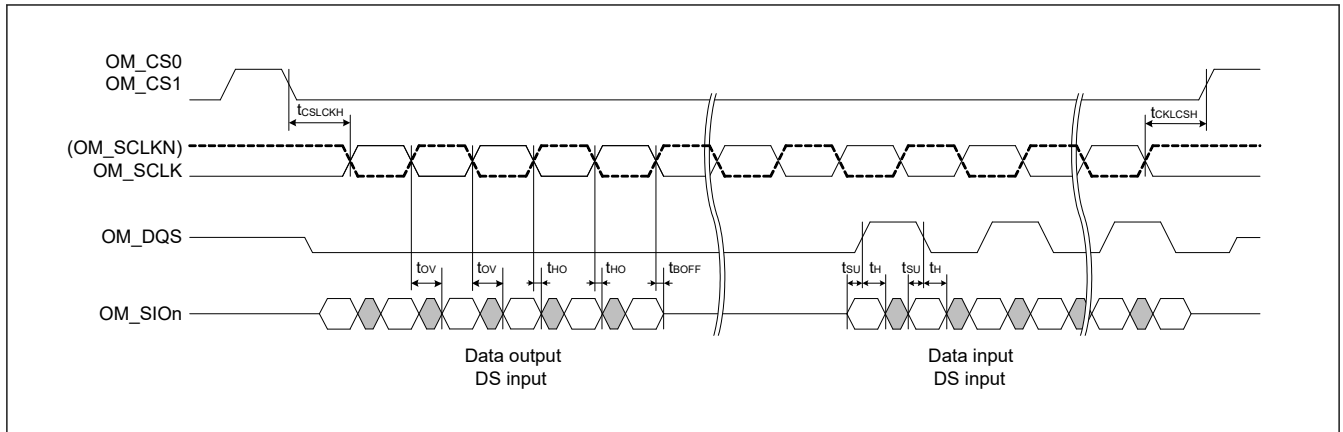

Figure 2.68 DDR transmit/receive timing (4S-4D-4D, 8D-8D-8D)

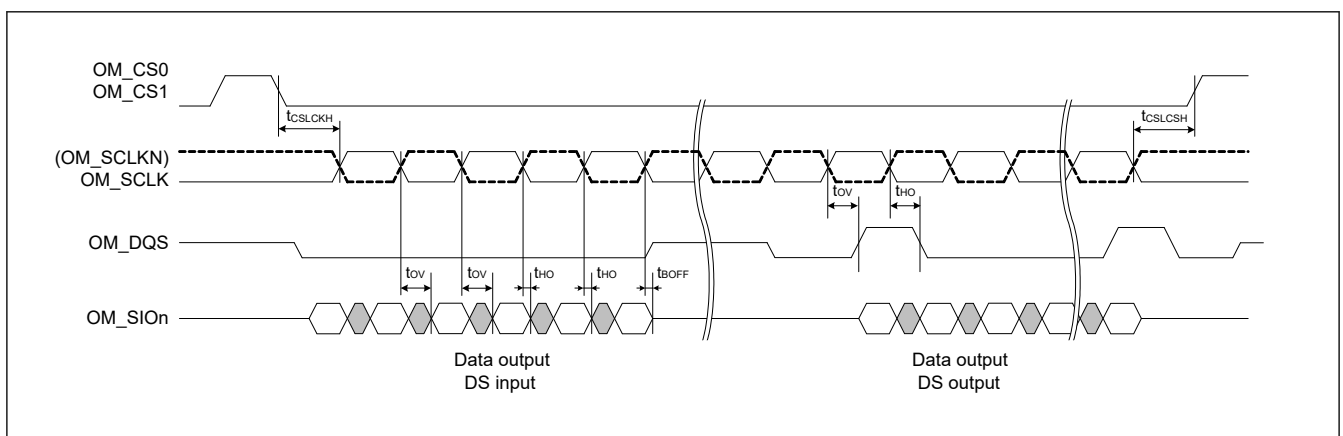

Figure 2.69 DDR transmit/receive timing (HyperRAM write)

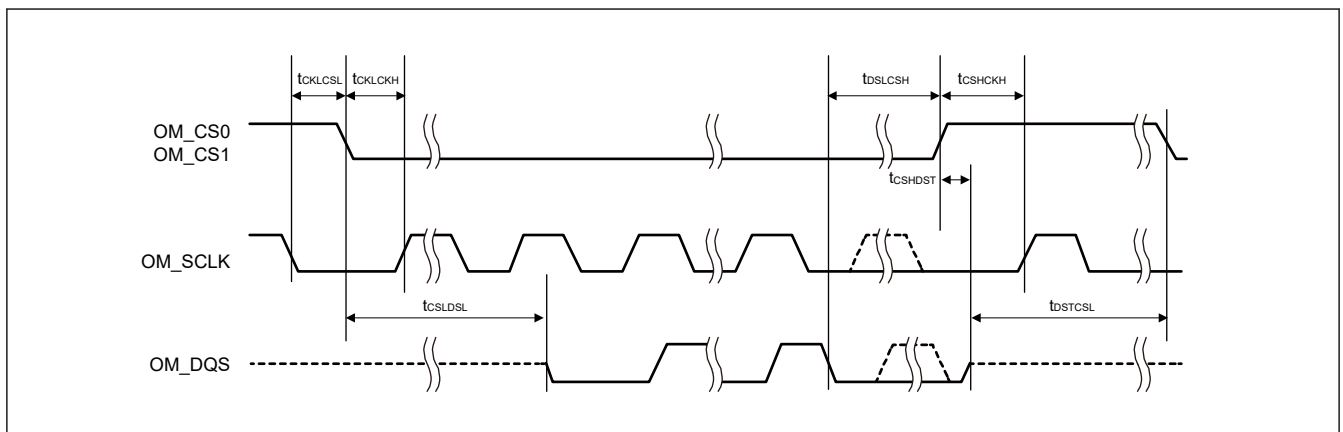

Figure 2.70 DS to CS signal timing

2.3.12 IIC Timing

Table 2.46 IIC timing (1) (1 of 2)

(1) Conditions: Middle drive output is selected when VCC is 2.70 V or above, High drive output is selected when VCC is 1.68 to 1.95 V in the port drive capability bit in the PmnPFS register for the following pins: SDA0_B, SCL0_B, SDA1_B, SCL1_B

(2) The following pins do not require setting: SCL0_A, SDA0_A, SCL1_A, SDA1_A

(3) Use pins that have a letter appended to their names, for instance “_A” or “_B”, to indicate group membership.

For the IIC interface, the AC portion of the electrical characteristics is measured for each group.

Parameter	Symbol	VCC	Min	Max	Unit	Test conditions	
IIC (Standard mode, SMBus) ICFER.FMPE = 0 when VCC is 2.70 V or above, ICFER.FMPE = 1 when VCC is 1.68 to 1.95 V	SCL input cycle time	t_{SCL}	2.70 V or above 1.68 to 1.95 V	$6 (12) \times t_{IICcyc} + 1300$	—	ns	Figure 2.71
	SCL input high pulse width	t_{SCLH}	2.70 V or above 1.68 to 1.95 V	$3 (6) \times t_{IICcyc} + 300$	—	ns	
	SCL input low pulse width	t_{SCLL}	2.70 V or above 1.68 to 1.95 V	$3 (6) \times t_{IICcyc} + 300$	—	ns	
	SCL, SDA rise time	t_{Sr}	2.70 V or above 1.68 to 1.95 V	—	1000	ns	
	SCL, SDA fall time	t_{Sf}	2.70 V or above 1.68 to 1.95 V	—	300	ns	
	SCL, SDA input spike pulse removal time	t_{SP}	2.70 V or above 1.68 to 1.95 V	0	$1 (4) \times t_{IICcyc}$	ns	
	SDA input bus free time when wakeup function is disabled	t_{BUF}	2.70 V or above 1.68 to 1.95 V	$3 (6) \times t_{IICcyc} + 300$	—	ns	
	SDA input bus free time when wakeup function is enabled	t_{BUF}	2.70 V or above 1.68 to 1.95 V	$3 (6) \times t_{IICcyc} + 4 \times t_{Pcyc} + 300$	—	ns	
	START condition input hold time when wakeup function is disabled	t_{STAH}	2.70 V or above 1.68 to 1.95 V	$t_{IICcyc} + 300$	—	ns	
	START condition input hold time when wakeup function is enabled	t_{STAH}	2.70 V or above 1.68 to 1.95 V	$1 (5) \times t_{IICcyc} + t_{Pcyc} + 300$	—	ns	
	Repeated START condition input setup time	t_{STAS}	2.70 V or above 1.68 to 1.95 V	1000	—	ns	
	STOP condition input setup time	t_{STOS}	2.70 V or above 1.68 to 1.95 V	1000	—	ns	
	Data input setup time	t_{SDAS}	2.70 V or above 1.68 to 1.95 V	$t_{IICcyc} + 50$	—	ns	
	Data input hold time	t_{SDAH}	2.70 V or above 1.68 to 1.95 V	0	—	ns	
	SCL, SDA capacitive load	C_b	2.70 V or above 1.68 to 1.95 V	—	400	pF	

Table 2.46 IIC timing (1) (2 of 2)

(1) Conditions: Middle drive output is selected when VCC is 2.70 V or above, High drive output is selected when VCC is 1.68 to 1.95 V in the port drive capability bit in the PmnPFS register for the following pins: SDA0_B, SCL0_B, SDA1_B, SCL1_B

(2) The following pins do not require setting: SCL0_A, SDA0_A, SCL1_A, SDA1_A

(3) Use pins that have a letter appended to their names, for instance "_A" or "_B", to indicate group membership.

For the IIC interface, the AC portion of the electrical characteristics is measured for each group.

Parameter	Symbol	VCC	Min	Max	Unit	Test conditions	
IIC (Fast mode) ICFER.FMPE = 0 when VCC is 2.70 V or above, ICFER.FMPE = 1 when VCC is 1.68 to 1.95 V	SCL input cycle time	t _{SCL}	2.70 V or above	6 (12) × t _{IICcyc} + 600	—	ns	Figure 2.71
		1.68 to 1.95 V					
	SCL input high pulse width	t _{SCLH}	2.70 V or above	3 (6) × t _{IICcyc} + 300	—	ns	
			1.68 to 1.95 V				
	SCL input low pulse width	t _{SCLL}	2.70 V or above	3 (6) × t _{IICcyc} + 300	—	ns	
			1.68 to 1.95 V				
	SCL, SDA rise time	t _{Sr}	2.70 V or above	20	300	ns	
			1.68 to 1.95 V				
	SCL, SDA fall time	t _{Sf}	2.70 V or above	20 × (external pullup voltage/5.5 V) ^{*1}	300	ns	
			1.68 to 1.95 V				
	SCL, SDA input spike pulse removal time	t _{SP}	2.70 V or above	0	1 (4) × t _{IICcyc}	ns	
			1.68 to 1.95 V				
	SDA input bus free time when wakeup function is disabled	t _{BUF}	2.70 V or above	3 (6) × t _{IICcyc} + 300	—	ns	
			1.68 to 1.95 V				
	SDA input bus free time when wakeup function is enabled	t _{BUF}	2.70 V or above	3 (6) × t _{IICcyc} + 4 × t _{Pcyc} + 300	—	ns	
			1.68 to 1.95 V				
START condition input hold time when wakeup function is disabled	t _{STAH}	2.70 V or above	t _{IICcyc} + 300	—	ns		
		1.68 to 1.95 V					
START condition input hold time when wakeup function is enabled	t _{STAH}	2.70 V or above	1 (5) × t _{IICcyc} + t _{Pcyc} + 300	—	ns		
		1.68 to 1.95 V					
Repeated START condition input setup time	t _{STAS}	2.70 V or above	300	—	ns		
		1.68 to 1.95 V					
STOP condition input setup time	t _{STOS}	2.70 V or above	300	—	ns		
		1.68 to 1.95 V					
Data input setup time	t _{SDAS}	2.70 V or above	t _{IICcyc} + 50	—	ns		
		1.68 to 1.95 V					
Data input hold time	t _{SDAH}	2.70 V or above	0	—	ns		
		1.68 to 1.95 V					
SCL, SDA capacitive load	C _b	2.70 V or above	—	400	pF		
		1.68 to 1.95 V					

Note: t_{IICcyc}: IIC internal reference clock (IICφ) cycle, t_{Pcyc}: PCLKB cycle.

Note: Values in parentheses apply when ICMR3.NF[1:0] is set to 11b while the digital filter is enabled with ICFER.NFE set to 1.

Note: Must use pins that have a letter appended to their name, for instance "_A", "_B", to indicate group membership. For the IIC interface, the AC portion of the electrical characteristics is measured for each group.

Note 1. Only supported for SCL0_A, SDA0_A, SCL1_A, and SDA1_A.

Table 2.47 IIC timing (2)

Setting of the SCL0_A, SDA0_A, SCL1_A, SDA1_A pins are not required with the port drive capability bit in the PmnPFS register.

Parameter		Symbol	VCC	Min	Max	Unit	Test conditions
IIC (Fast-mode+) ICFER.FMPE = 1	SCL input cycle time	t_{SCL}	2.70 V or above	$6 (12) \times t_{IICcyc} + 240$	—	ns	Figure 2.71
	SCL input high pulse width	t_{SCLH}	2.70 V or above	$3 (6) \times t_{IICcyc} + 120$	—	ns	
	SCL input low pulse width	t_{SCLL}	2.70 V or above	$3 (6) \times t_{IICcyc} + 120$	—	ns	
	SCL, SDA rise time	t_{Sr}	2.70 V or above	—	120	ns	
	SCL, SDA fall time	t_{Sf}	2.70 V or above	$20 \times (\text{external pullup voltage} / 5.5V)$	120	ns	
	SCL, SDA input spike pulse removal time	t_{SP}	2.70 V or above	0	$1 (4) \times t_{IICcyc}$	ns	
	SDA input bus free time when wakeup function is disabled	t_{BUF}	2.70 V or above	$3 (6) \times t_{IICcyc} + 120$	—	ns	
	SDA input bus free time when wakeup function is enabled	t_{BUF}	2.70 V or above	$3 (6) \times t_{IICcyc} + 4 \times t_{Pcyc} + 120$	—	ns	
	Start condition input hold time when wakeup function is disabled	t_{STAH}	2.70 V or above	$t_{IICcyc} + 120$	—	ns	
	START condition input hold time when wakeup function is enabled	t_{STAH}	2.70 V or above	$1 (5) \times t_{IICcyc} + t_{Pcyc} + 120$	—	ns	
	Restart condition input setup time	t_{STAS}	2.70 V or above	120	—	ns	
	Stop condition input setup time	t_{STOS}	2.70 V or above	120	—	ns	
	Data input setup time	t_{SDAS}	2.70 V or above	$t_{IICcyc} + 30$	—	ns	
	Data input hold time	t_{SDAH}	2.70 V or above	0	—	ns	
SCL, SDA capacitive load	C_b^{*1}	2.70 V or above	—	550	pF		

Note: t_{IICcyc} : IIC internal reference clock (IIC ϕ) cycle, t_{Pcyc} : PCLKB cycle.

Note: Values in parentheses apply when ICMR3.NF[1:0] is set to 11b while the digital filter is enabled with ICFER.NFE set to 1.

Note 1. C_b indicates the total capacity of the bus line.

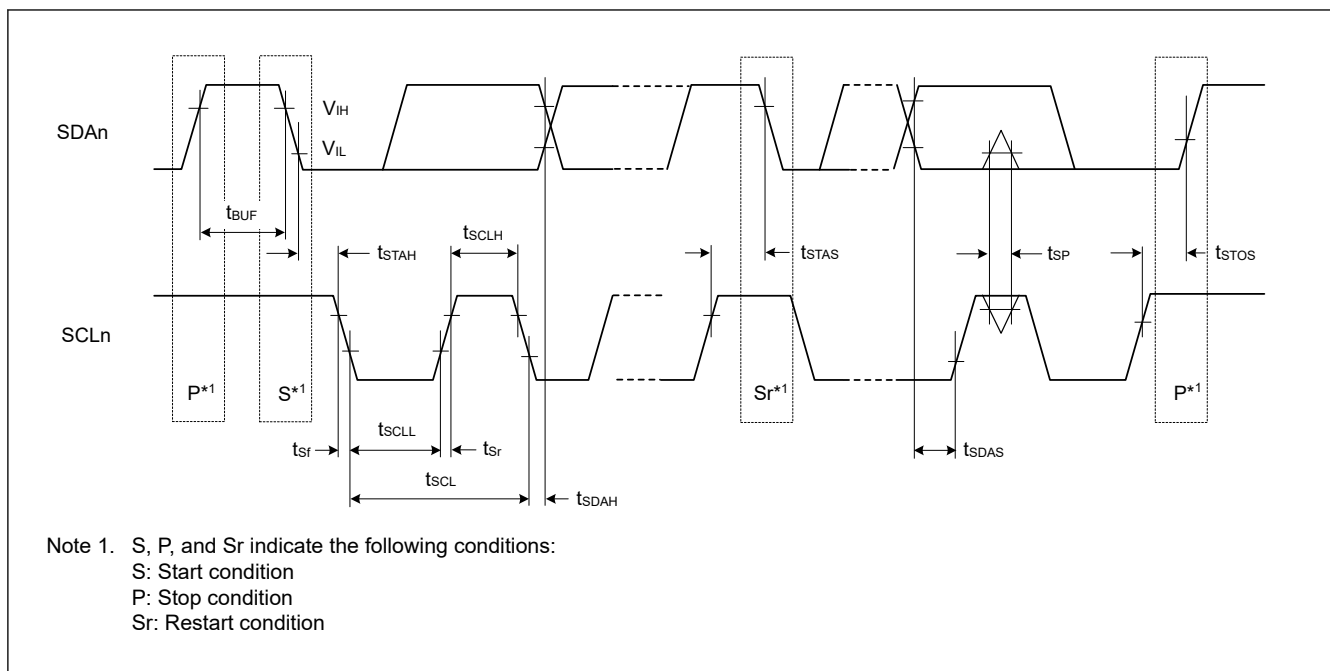

Figure 2.71 I²C bus interface input/output timing

2.3.13 I3C Timing

Table 2.48 IIC timing(1)-1

Setting of the I3C_SCL0, I3C_SDA0 pins are not required with the Port Drive Capability bit in the PmnPFS register.

Parameter	Symbol	VCC	Min	Max	Unit	
IIC (Standard mode, SMBus) BFCTL.FMPE = 0	SCL input cycle time	t_{SCL}	2.70 V or above, 1.68 to 1.95 V	$10 (18) \times t_{I3CCyc} + 1300$	—	ns
	SCL input high pulse width	t_{SCLH}	2.70 V or above, 1.68 to 1.95 V	$5 (9) \times t_{I3CCyc} + 300$	—	ns
	SCL input low pulse width	t_{SCLL}	2.70 V or above, 1.68 to 1.95 V	$5 (9) \times t_{I3CCyc} + 300$	—	ns
	SCL, SDA rise time	t_{Sr}	2.70 V or above, 1.68 to 1.95 V	—	1000	ns
	SCL, SDA fall time	t_{Sf}	2.70 V or above, 1.68 to 1.95 V	—	300	ns
	SCL, SDA input spike pulse removal time	t_{SP}	2.70 V or above, 1.68 to 1.95 V	0	$1 (4) \times t_{I3CCyc}$	ns
	SDA input bus free time when wakeup function is disabled	t_{BUF}	2.70 V or above, 1.68 to 1.95 V	$5(9) \times t_{I3CCyc} + 300$	—	ns
	SDA input bus free time when wakeup function is enabled	t_{BUF}	2.70 V or above, 1.68 to 1.95 V	$5(9) \times t_{I3CCyc} + 4 \times t_{Tcyc} + 300$	—	ns
	START condition input hold time when wakeup function is disabled	t_{STAH}	2.70 V or above, 1.68 to 1.95 V	$t_{I3CCyc} + 300$	—	ns
	START condition input hold time when wakeup function is enabled	t_{STAH}	2.70 V or above, 1.68 to 1.95 V	$1(5) \times t_{I3CCyc} + t_{Tcyc} + 300$	—	ns
	Repeated START condition input setup time	t_{STAS}	2.70 V or above, 1.68 to 1.95 V	1000	—	ns
	STOP condition input setup time	t_{STOS}	2.70 V or above, 1.68 to 1.95 V	1000	—	ns
	Data input setup time	t_{SDAS}	2.70 V or above, 1.68 to 1.95 V	$t_{I3CCyc} + 50$	—	ns
	Data input hold time	t_{SDAH}	2.70 V or above, 1.68 to 1.95 V	0	—	ns
SCL, SDA capacitive load	C_b^{*1}	2.70 V or above, 1.68 to 1.95 V	—	400	pF	

Note: t_{I3CCyc} : I3C internal reference clock (I3C ϕ) cycle, t_{Tcyc} : TCLK cycle.

Note: Values in parentheses apply when INCTL.DNFS[3:0] is set to 0011b while the digital filter is enabled with INCTL.DNFE set to 1.

Note 1. C_b indicates the total capacity of the bus line.

Table 2.49 IIC timing(1)-2

Setting of the I3C_SCL0, I3C_SDA0 pins are not required with the Port Drive Capability bit in the PmnPFS register.

Parameter	Symbol	VCC	Min	Max	Unit	
IIC (Fast-mode)	SCL input cycle time	t_{SCL}	2.70 V or above, 1.68 to 1.95 V	$10 (18) \times t_{I3CCyc} + 600$	—	ns
	SCL input high pulse width	t_{SCLH}	2.70 V or above, 1.68 to 1.95 V	$5 (9) \times t_{I3CCyc} + 300$	—	ns
	SCL input low pulse width	t_{SCLL}	2.70 V or above, 1.68 to 1.95 V	$5 (9) \times t_{I3CCyc} + 300$	—	ns
	SCL, SDA rise time	t_{Sr}	2.70 V or above, 1.68 to 1.95 V	20	300	ns
	SCL, SDA fall time	t_{Sf}	2.70 V or above, 1.68 to 1.95 V	$20 \times (\text{external pull-up voltage}/3.6 \text{ V})$	300	ns
	SCL, SDA input spike pulse removal time	t_{SP}	2.70 V or above, 1.68 to 1.95 V	0	$1 (4) \times t_{I3CCyc}$	ns
	SDA input bus free time when wakeup function is disabled	t_{BUF}	2.70 V or above, 1.68 to 1.95 V	$5 (9) \times t_{I3CCyc} + 300$	—	ns
	SDA input bus free time when wakeup function is enabled		2.70 V or above, 1.68 to 1.95 V	$5(9) \times t_{I3CCyc} + 4 \times t_{TCyc} + 300$	—	ns
	START condition input hold time when wakeup function is disabled	t_{STAH}	2.70 V or above, 1.68 to 1.95 V	$t_{I3CCyc} + 300$	—	ns
	START condition input hold time when wakeup function is enabled		2.70 V or above, 1.68 to 1.95 V	$1(5) \times t_{I3CCyc} + t_{TCyc} + 300$	—	ns
	Repeated START condition input setup time	t_{STAS}	2.70 V or above, 1.68 to 1.95 V	300	—	ns
	STOP condition input setup time	t_{STOS}	2.70 V or above, 1.68 to 1.95 V	300	—	ns
	Data input setup time	t_{SDAS}	2.70 V or above, 1.68 to 1.95 V	$t_{I3CCyc} + 50$	—	ns
	Data input hold time	t_{SDAH}	2.70 V or above, 1.68 to 1.95 V	0	—	ns
	SCL, SDA capacitive load	C_b^{*1}	2.70 V or above, 1.68 to 1.95 V	—	400	pF

Note: t_{I3CCyc} : I3C internal reference clock (I3C ϕ) cycle, t_{TCyc} : TCLK cycle.

Note: Values in parentheses apply when INCTL.DNFS[3:0] is set to 0011b while the digital filter is enabled with INCTL.DNFE set to 1.

Note 1. C_b indicates the total capacity of the bus line.

Table 2.50 IIC timing(1)-3

Setting of the I3C_SCL0, I3C_SDA0 pins are not required with the Port Drive Capability bit in the PmnPFS register.

Parameter	Symbol	VCC	Min	Max	Unit	
IIC (Fast-mode +) BFCTL.FMPE = 1	SCL input cycle time	t_{SCL}	2.70 V or above	$10 (18) \times t_{I3C_{Cyc}} + 240$	—	ns
	SCL input high pulse width	t_{SCLH}	2.70 V or above	$5 (9) \times t_{I3C_{Cyc}} + 120$	—	ns
	SCL input low pulse width	t_{SCLL}	2.70 V or above	$5 (9) \times t_{I3C_{Cyc}} + 120$	—	ns
	SCL, SDA rise time	t_{Sr}	2.70 V or above	—	120	ns
	SCL, SDA fall time	t_{Sf}	2.70 V or above	$20 \times (\text{external pull-up voltage}/3.3V)$	120	ns
	SCL, SDA input spike pulse removal time	t_{SP}	2.70 V or above	0	$1 (4) \times t_{I3C_{Cyc}}$	ns
	SDA input bus free time when wakeup function is disabled	t_{BUF}	2.70 V or above	$5 (9) \times t_{I3C_{Cyc}} + 120$	—	ns
	SDA input bus free time when wakeup function is enabled			$5(9) \times t_{I3C_{Cyc}} + 4 \times t_{T_{Cyc}} + 120$	—	ns
	START condition input hold time when wakeup function is disabled	t_{STAH}	2.70 V or above	$t_{I3C_{Cyc}} + 120$	—	ns
	START condition input hold time when wakeup function is enabled			$1(5) \times t_{I3C_{Cyc}} + t_{T_{Cyc}} + 120$	—	ns
	Restart condition input setup time	t_{STAS}	2.70 V or above	120	—	ns
	Stop condition input setup time	t_{STOS}	2.70 V or above	120	—	ns
	Data input setup time	t_{SDAS}	2.70 V or above	$t_{I3C_{Cyc}} + 30$	—	ns
	Data input hold time	t_{SDAH}	2.70 V or above	0	—	ns
	SCL, SDA capacitive load	C_b^{*1}	2.70 V or above	—	550	pF

Note: $t_{I3C_{Cyc}}$: I3C internal reference clock (I3C ϕ) cycle. $t_{T_{Cyc}}$: TCLK cycle.

Note: Values in parentheses apply when INCTL.DNFS[3:0] is set to 0011b while the digital filter is enabled with INCTL.DNFE set to 1.

Note 1. C_b indicates the total capacity of the bus line.

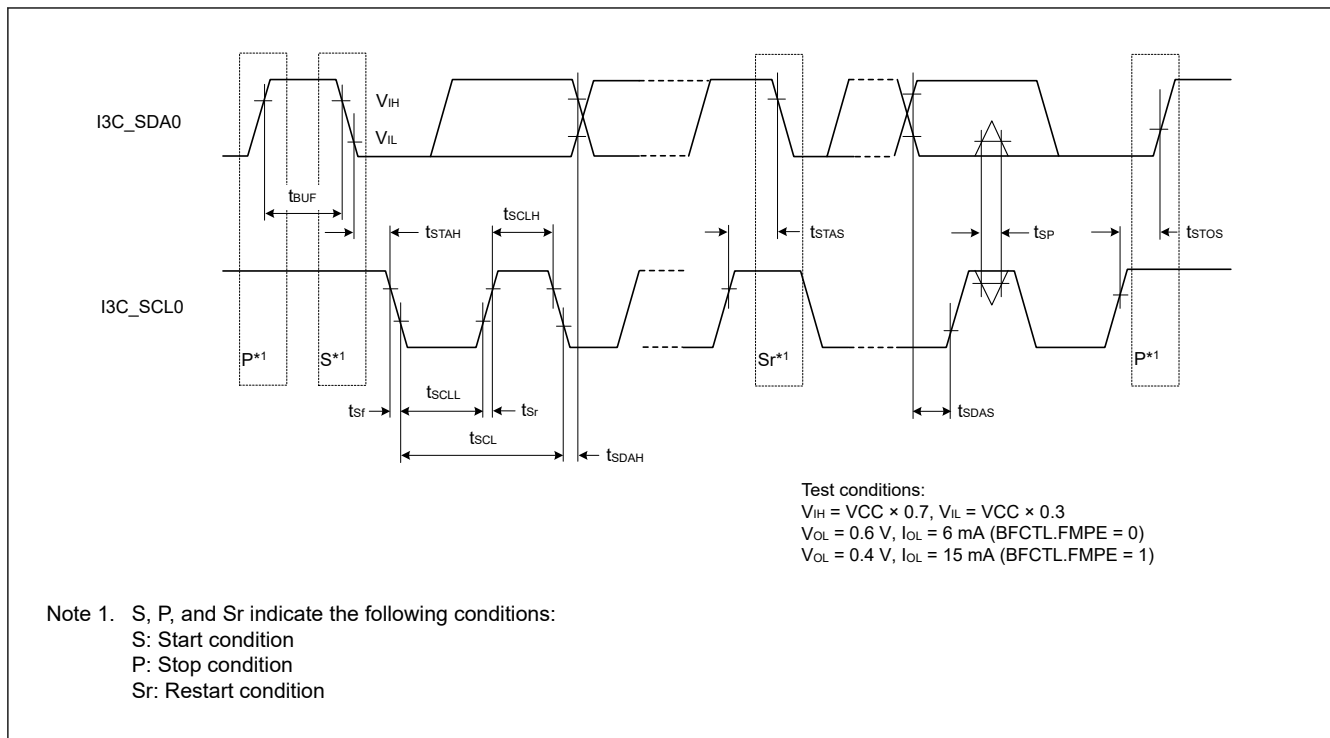

Figure 2.72 I²C bus interface input/output timing

Table 2.51 IIC timing(2)

Setting of the I3C_SCL0, I3C_SDA0 pins are not required with the Port Drive Capability bit in the PmnPFS register.

Parameter		Symbol	VCC	Min	Max	Unit	
IIC (Hs-mode) BFCTL.HS ME = 1	SCL input cycle time		t _{SCL}	3.00 V or above	47 (49) × t _{I3CcyC}	—	ns
				1.68 to 1.95 V	48 (50) × t _{I3CcyC}	—	
	SCL input high pulse width	Cb = 400 pF	t _{SCLH}	3.00 V or above	36 (37) × t _{I3CcyC}	—	ns
				1.68 to 1.95 V	31 (32) × t _{I3CcyC}	—	
		Cb = 100 pF		3.00 V or above	18 (19) × t _{I3CcyC}	—	
				1.68 to 1.95 V	19 (20) × t _{I3CcyC}	—	
	SCL input low pulse width	Cb = 400 pF	t _{SCLL}	3.00 V or above	61 (62) × t _{I3CcyC}	—	ns
				1.68 to 1.95 V	61 (62) × t _{I3CcyC}	—	
		Cb = 100 pF		3.00 V or above	29 (30) × t _{I3CcyC}	—	
				1.68 to 1.95 V	29 (30) × t _{I3CcyC}	—	
	SCL rise time	Cb = 400 pF	t _{SrCL}	3.00 V or above	—	80	ns
				1.68 to 1.95 V	—	80	
		Cb = 100 pF		3.00 V or above	—	40	
				1.68 to 1.95 V	—	40	
	SDA rise time	Cb = 400 pF	t _{SrDA}	3.00 V or above	—	160	ns
				1.68 to 1.95 V	—	160	
		Cb = 100 pF		3.00 V or above	—	80	
				1.68 to 1.95 V	—	80	
	SCL fall time	Cb = 400 pF	t _{SfCL}	3.00 V or above	—	80	ns
				1.68 to 1.95 V	—	80	
Cb = 100 pF		3.00 V or above		—	40		
		1.68 to 1.95 V		—	40		
SDA fall time	Cb = 400 pF	t _{SfDA}	3.00 V or above	—	160	ns	
			1.68 to 1.95 V	—	160		
	Cb = 100 pF		3.00 V or above	—	80		
			1.68 to 1.95 V	—	80		
SCL, SDA input spike pulse removal time		t _{SP}	3.00 V or above	0	1 (1) × t _{I3CcyC}	ns	
			1.68 to 1.95 V	0	1 (1) × t _{I3CcyC}		
Repeated START condition input setup time		t _{STAS}	3.00 V or above	40	—	ns	
			1.68 to 1.95 V	40	—		
STOP condition input setup time		t _{STOS}	3.00 V or above	40	—	ns	
			1.68 to 1.95 V	40	—		
Data input setup time		t _{SDAS}	3.00 V or above	10	—	ns	
			1.65 to 1.95 V	10	—		
Data input hold time	Cb = 400 pF	t _{SDAH}	3.00 V or above	0	150	ns	
			1.68 to 1.95 V	0	150		
	Cb = 100 pF		3.00 V or above	0	70		
			1.68 to 1.95 V	0	70		
SCL, SDA capacitive load		C _b ^{*1}	3.00 V or above	—	400	pF	
			1.68 to 1.95 V	—	400		

Note: t_{13Cyc} : I3C internal reference clock (I3C ϕ) cycle.

Note: Values in parentheses apply when INCTL.DNFS[3:0] is set to 0011b while the digital filter is enabled with INCTL.DNFE set to 1.

Note 1. C_b indicates the total capacity of the bus line.

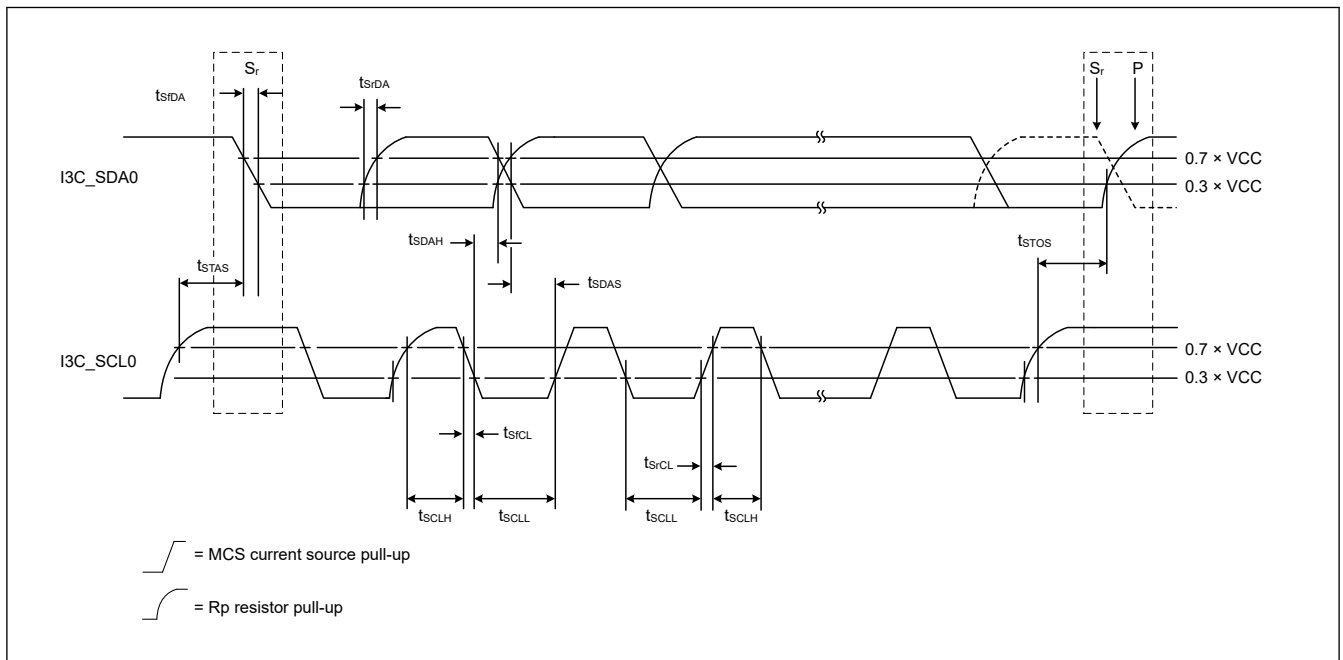

Figure 2.73 I²C bus interface input/output timing (Hs-mode)

Table 2.52 I3C timing (Open Drain Timing Parameters)

Setting of the I3C_SCL0, I3C_SDA0 pins are not required with the Port Drive Capability bit in the PmnPFS register.

Parameter	Symbol	VCC	Min	Max	Unit	Test conditions	
I3C Open Drain Timing Parameters	SCL Clock Low Period	$t_{LOW_OD}^{*1 *2}$	3.00 V or above	200	—	ns	Figure 2.76
			1.68 to 1.95 V	200	—		
	$t_{DIG_OD_L}$	3.00 V or above	$t_{LOW_ODmin} + t_{fDA_ODmin}$	—	ns	Figure 2.76	
		1.68 to 1.95 V	$t_{LOW_ODmin} + t_{fDA_ODmin}$	—			
	SCL Clock High Period	$t_{HIGH}^{*3 *4}$	3.00 V or above	—	41	ns	Figure 2.74
			1.68 to 1.95 V	—	41		
	t_{DIG_H}	3.00 V or above	—	$t_{HIGH} + t_{CF}$	ns	Figure 2.74	
		1.68 to 1.95 V	—	$t_{HIGH} + t_{CF}$			
	SDA Signal Fall Time	t_{fDA_OD}	3.00 V or above	t_{CF}	12	ns	Figure 2.76
			1.68 to 1.95 V	t_{CF}	12		
	SDA Data Setup Time Open Drain Mode	$t_{SU_OD}^{*1}$	3.00 V or above	12	—	ns	Figure 2.75
			1.68 to 1.95 V	18	—		
Clock After START (S) Condition	$t_{CAS}^{*5 *6}$	3.00 V or above	38.4 nano	For ENAS0: 1 μ	seconds	Figure 2.76	
				For ENAS1: 100 μ			
				For ENAS2: 2 milli			
				For ENAS3: 50 milli			
1.68 to 1.95 V	38.4 nano	For ENAS0: 1 μ					
		For ENAS1: 100 μ					
		For ENAS2: 2 milli					
		For ENAS3: 50 milli					
Clock Before STOP (P) Condition	t_{CBP}	3.00 V or above	$t_{CASmin} / 2$	—	seconds	Figure 2.77	
		1.68 to 1.95 V	$t_{CASmin} / 2$	—			
Current Master to Secondary Master Overlap time during handoff	$t_{MMOverlap}$	3.00 V or above	$t_{DIG_OD_Lmin}$	—	ns	Figure 2.83	
		1.68 to 1.95 V	$t_{DIG_OD_Lmin}$	—			
Bus Available Condition	t_{AVAL}^{*7}	3.00 V or above	1	—	μ s	—	
		1.68 to 1.95 V	1	—			
Bus Idle Condition	t_{IDLE}	3.00 V or above	1	—	ms	—	
		1.68 to 1.95 V	1	—			
Time Internal Where New Master Not Driving SDA Low	t_{MMLock}	3.00 V or above	$t_{AVALmin}$	—	μ s	Figure 2.83	
		1.68 to 1.95 V	$t_{AVALmin}$	—			

Note 1. This is approximately equal to $t_{LOWmin} + t_{DS_ODmin} + t_{rDA_ODtyp} + t_{SU_ODmin}$.

Note 2. The Master may use a shorter Low period if it knows that this is safe, i.e., that SDA is already above VIH

Note 3. Based on t_{SPIKE} , rise and fall times, and interconnectNote 4. This maximum High period may be exceeded when the signals can be safely seen by Legacy I²C Devices, and/or in consideration of the interconnect (e.g., a short Bus).

As a product specification, if this Max value cannot be guaranteed, change this Max value and specify that it cannot be used in the Mixed Bus.

Note 5. On a Legacy Bus where I²C Devices need to see Start

Note 6. Slaves that do not support the optional ENTASx CCCs shall use the t_{CAS} Max value shown for ENTAS3

Note 7. On a Mixed Bus with Fm Legacy I²C Devices, t_{AVAIL} is 300 ns shorter than the Fm Bus Free Condition time (t_{BUF})

Table 2.53 I3C timing (Push-Pull Timing Parameters for SDR and HDR-DDR Modes)

Setting of the I3C_SCL0, I3C_SDA0 pins are not required with the Port Drive Capability bit in the PmnPFS register.

Parameter		Symbol	VCC	Min	Max	Unit	Test conditions
I3C Push-Pull Timing Parameters for SDR and HDR-DDR Modes	SCL Clock Frequency	f _{SCL} ^{*1}	3.00 V or above	0.01	12.5	MHz	—
			1.68 to 1.95 V	0.01	12.5		
	SCL Clock Low Period	t _{LOW}	3.00 V or above	27	—	ns	Figure 2.74
			1.68 to 1.95 V	32	—		
		t _{DIG_L} ^{*2 *4}	3.00 V or above	35	—	ns	Figure 2.74
			1.68 to 1.95 V	40	—		
	SCL Clock High Period for Mixed Bus	t _{HIGH_MIXED}	3.00 V or above	24	—	ns	Figure 2.74
			1.68 to 1.95 V	27	—		
		t _{DIG_H_MIXED} ^{*2 *3}	3.00 V or above	32	45	ns	Figure 2.74
			1.68 to 1.95 V	35	45		
	SCL Clock High Period	t _{HIGH}	3.00 V or above	24	—	ns	Figure 2.74
			1.68 to 1.95 V	27	—		
		t _{DIG_H} ^{*2}	3.00 V or above	32	—	ns	Figure 2.74
			1.68 to 1.95 V	35	—		
	Clock in to Data Out for Slave	t _{SCO}	3.00 V or above	—	12	ns	Figure 2.79
			1.68 to 1.95 V	—	12		
	SCL Clock Rise Time	t _{CR}	3.00 V or above	—	150 × 1 / f _{SCL} (capped at 60)	ns	Figure 2.74
			1.68 to 1.95 V	—	150 × 1 / f _{SCL} (capped at 60)		
	SCL Clock Fall Time	t _{CF}	3.00 V or above	—	150 × 1 / f _{SCL} (capped at 60)	ns	Figure 2.74
			1.68 to 1.95 V	—	150 × 1 / f _{SCL} (capped at 60)		
SDA Signal Data Hold in Push-Pull Mode	Master	t _{HD_PP} ^{*4*5}	3.00 V or above	t _{CR} + 3 and t _{CF} + 3	—	—	Figure 2.78
			1.68 to 1.95 V	t _{CR} + 3 and t _{CF} + 3	—		
	Slave	t _{HD_PP} ^{*5}	3.00 V or above	0	—	—	Figure 2.78
			1.68 to 1.95 V	0	—		
SDA Signal Data Setup in Push-Pull Mode	t _{SU_PP}	3.00 V or above	12	N/A	ns	Figure 2.80	
		1.68 to 1.95 V	18	N/A			
Clock After Repeated START (Sr)	t _{CASr}	3.00 V or above	t _{CASmin}	N/A	ns	Figure 2.82	
		1.68 to 1.95 V	t _{CASmin}	N/A			
Clock Before Repeated START (Sr)	t _{CBSr}	3.00 V or above	t _{CASmin} / 2	N/A	ns	Figure 2.82	
		1.68 to 1.95 V	t _{CASmin} / 2	N/A			
Capacitive Load per Bus Line (SDA/SCL)	C _b	3.00 V or above	—	50	pF	—	
		1.68 to 1.95 V	—	50			

- Note 1. $f_{SCL} = 1 / (t_{DIG_L} + t_{DIG_H})$
- Note 2. t_{DIG_L} and t_{DIG_H} are the clock Low and High periods as seen at the receiver end of the I3C Bus using V_{IL} and V_{IH} .
- Note 3. When communicating with an I3C Device on a mixed Bus, the $t_{DIG_H_MIXED}$ period must be constrained in order to make sure that I²C Devices do not interpret I3C signaling as valid I²C signaling.
- Note 4. As both edges are used, the hold time needs to be satisfied for the respective edges; i.e., $t_{CF} + 3$ for falling edge clocks, and $t_{CR} + 3$ for rising edge clocks.
- Note 5. In SDR Mode the Hold time parameter is referred to as t_{HD_SDR} , and in DDR Mode it is referred to as t_{HD_DDR} .

Table 2.54 I3C timing (Push-Pull Timing Parameters for HDR-TSP and HDR-TSL Modes)

Setting of the I3C_SCL0, I3C_SDA0 pins are not required with the Port Drive Capability bit in the PmnPFS register.

Parameter	Symbol	VCC	Min	Max	Unit	Test conditions	
I3C Push-Pull Timing Parameters for HDR-TSP and HDR-TSL Modes	Edge-to-Edge Period	$t_{EDGE}^{*1 *2}$	3.00 V or above	t_{DIG_H}	—	ns	Figure 2.74
			1.68 to 1.95 V	t_{DIG_H}	—		
	Allowed Difference Between Signals for 'Simultaneous' Change	t_{SKEW}	3.00 V or above	—	10	ns	
			1.68 to 1.95 V	—	10		
	Stable Condition Between Symbols	t_{EYE}	3.00 V or above	12	—	ns	
			1.68 to 1.95 V	12	—		
	Time Between Successive Symbols	t_{SYMBOL}	3.00 V or above	$t_{EDGE} \text{ Min}$	—	ns	
			1.68 to 1.95 V	$t_{EDGE} \text{ Min}$	—		
	Symbol Clock	t_{CLOCK}	3.00 V or above	$1 / f_{SCL} \text{ (Max)}$	—	—	
			1.68 to 1.95 V	$1 / f_{SCL} \text{ (Max)}$	—		

- Note 1. Edges occur at the rate of $1 / (t_{EDGE} \times 2)$
- Note 2. In a Mixed Bus, HDR-TSL shall respect the maximum $t_{DIG_H_MIXED}$ shown in Figure 2.77.

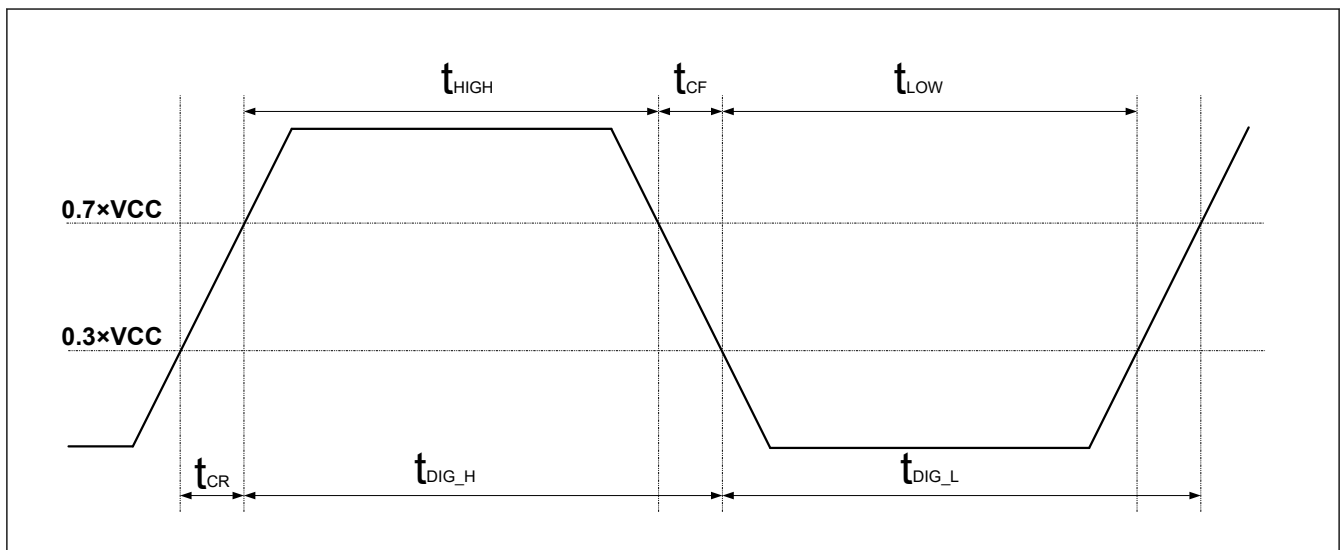

Figure 2.74 t_{DIG_H} and t_{DIG_L}

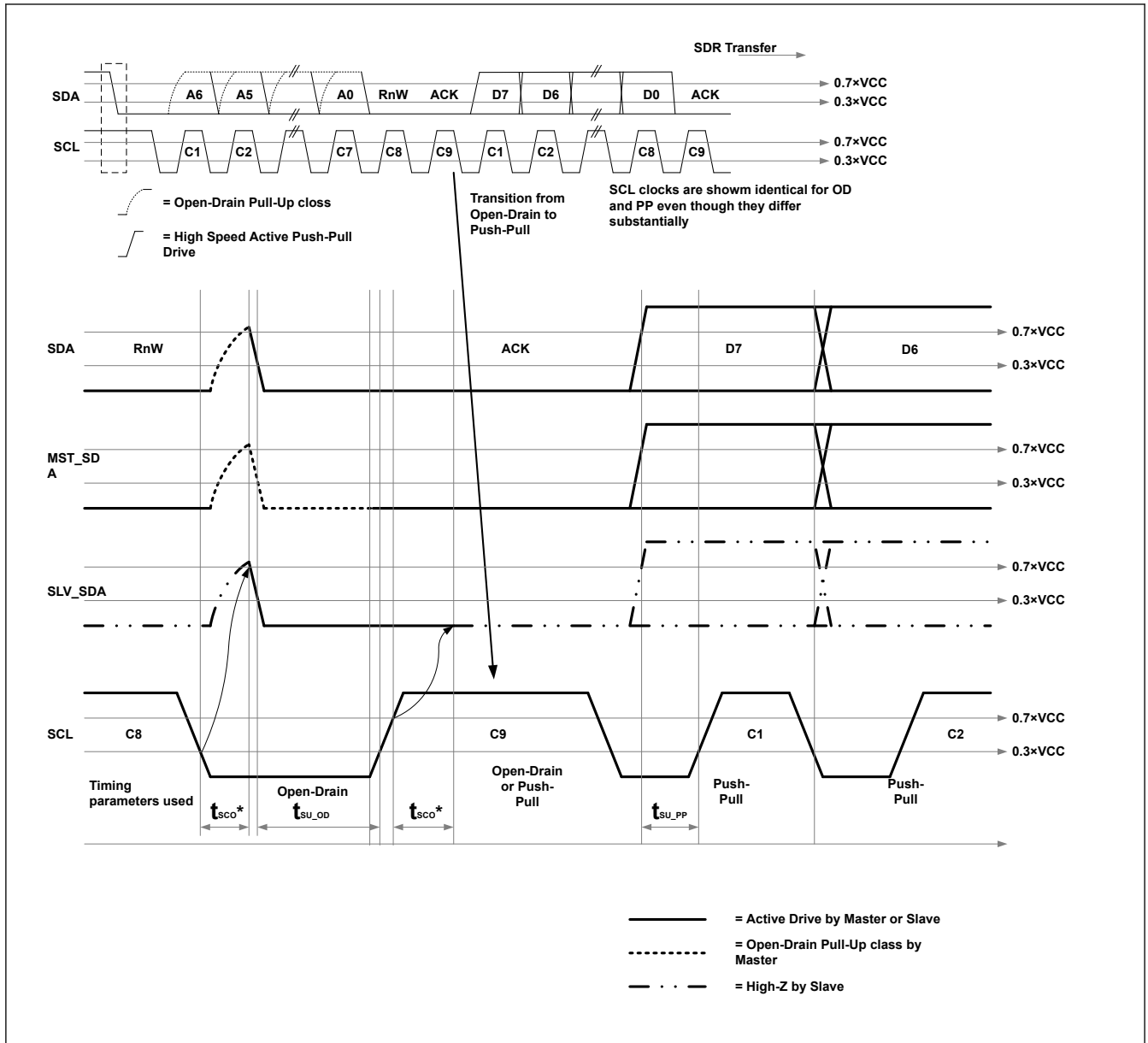

Figure 2.75 I3C Data Transfer – ACK by Slave

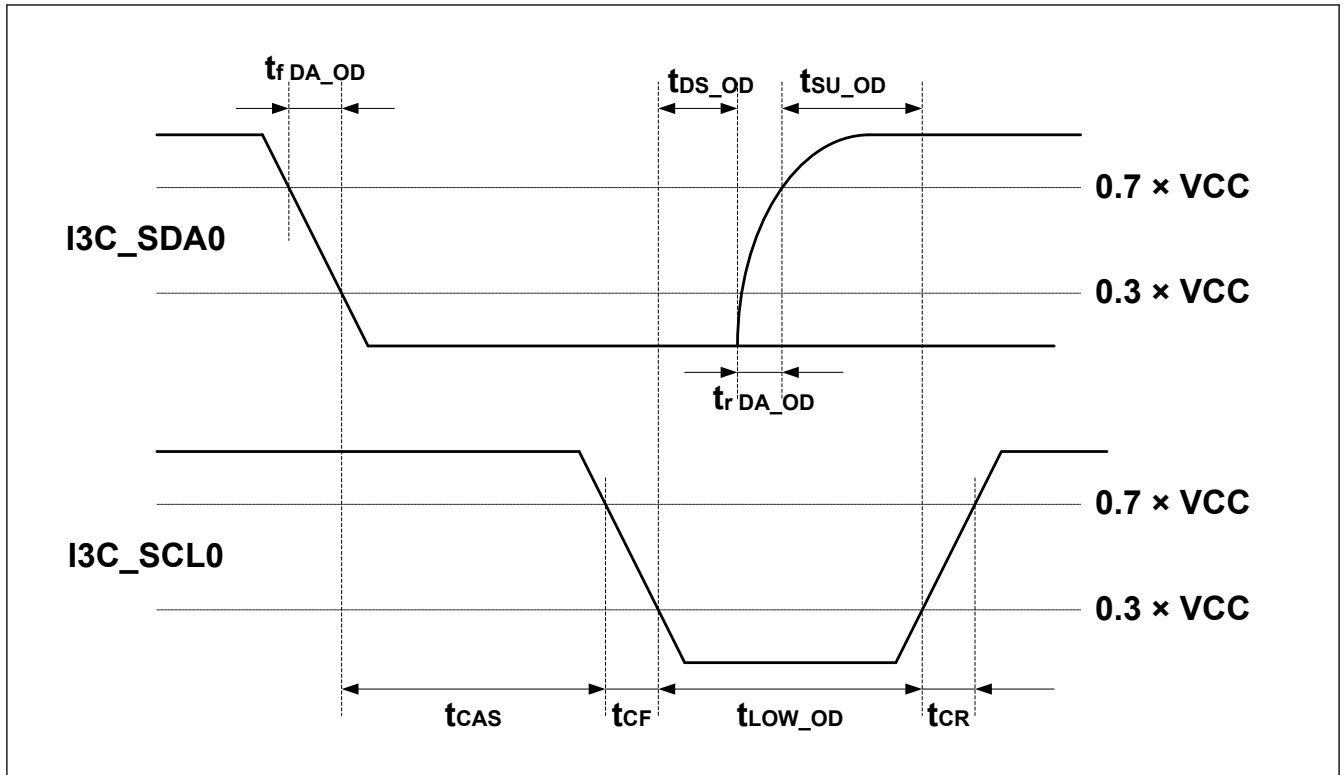

Figure 2.76 I3C START condition Timing

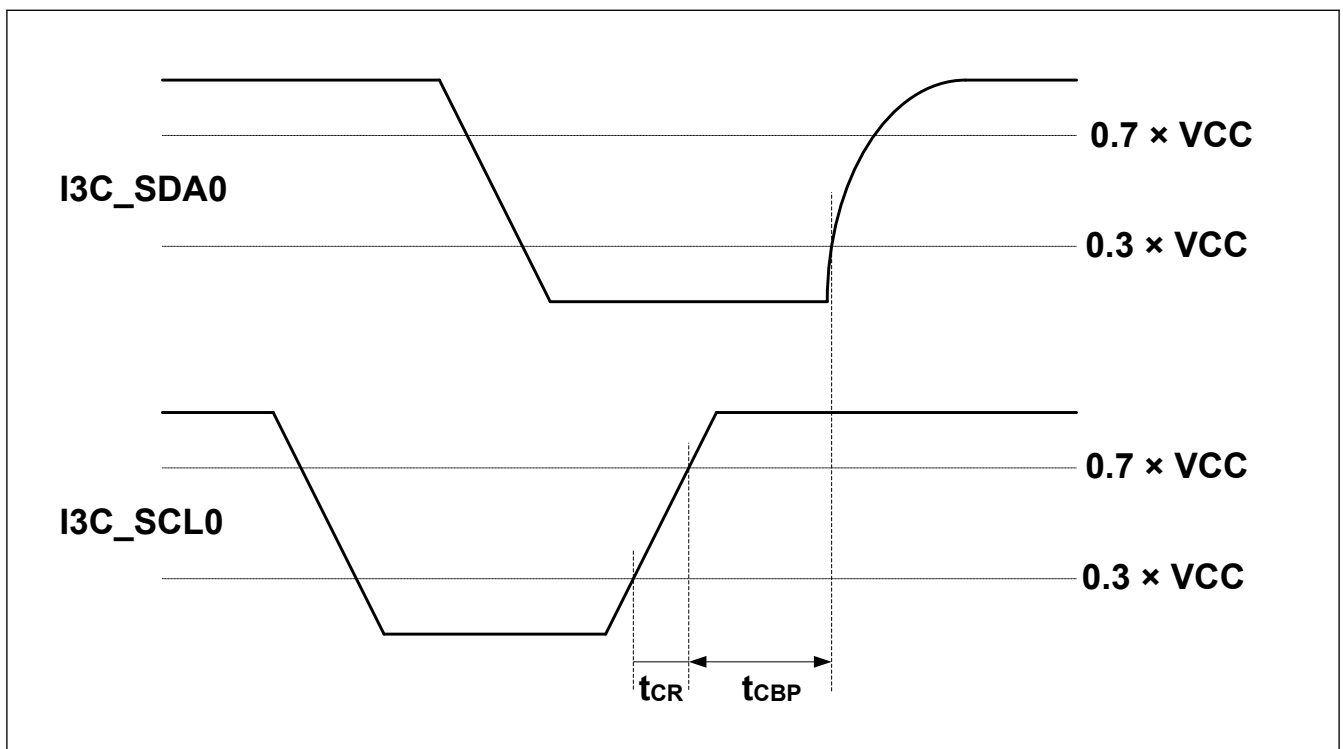

Figure 2.77 I3C STOP condition Timing

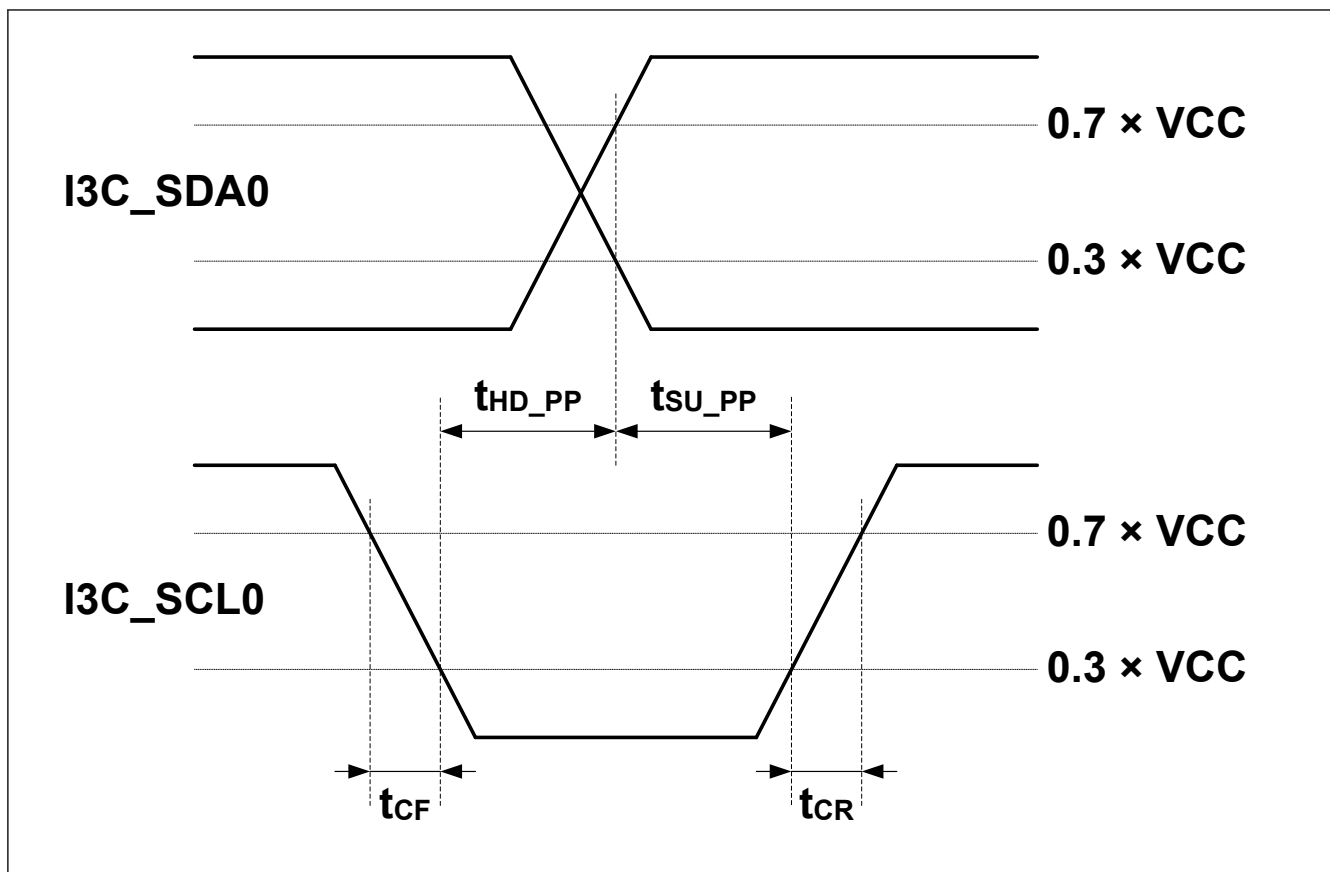

Figure 2.78 I3C Master Out Timing

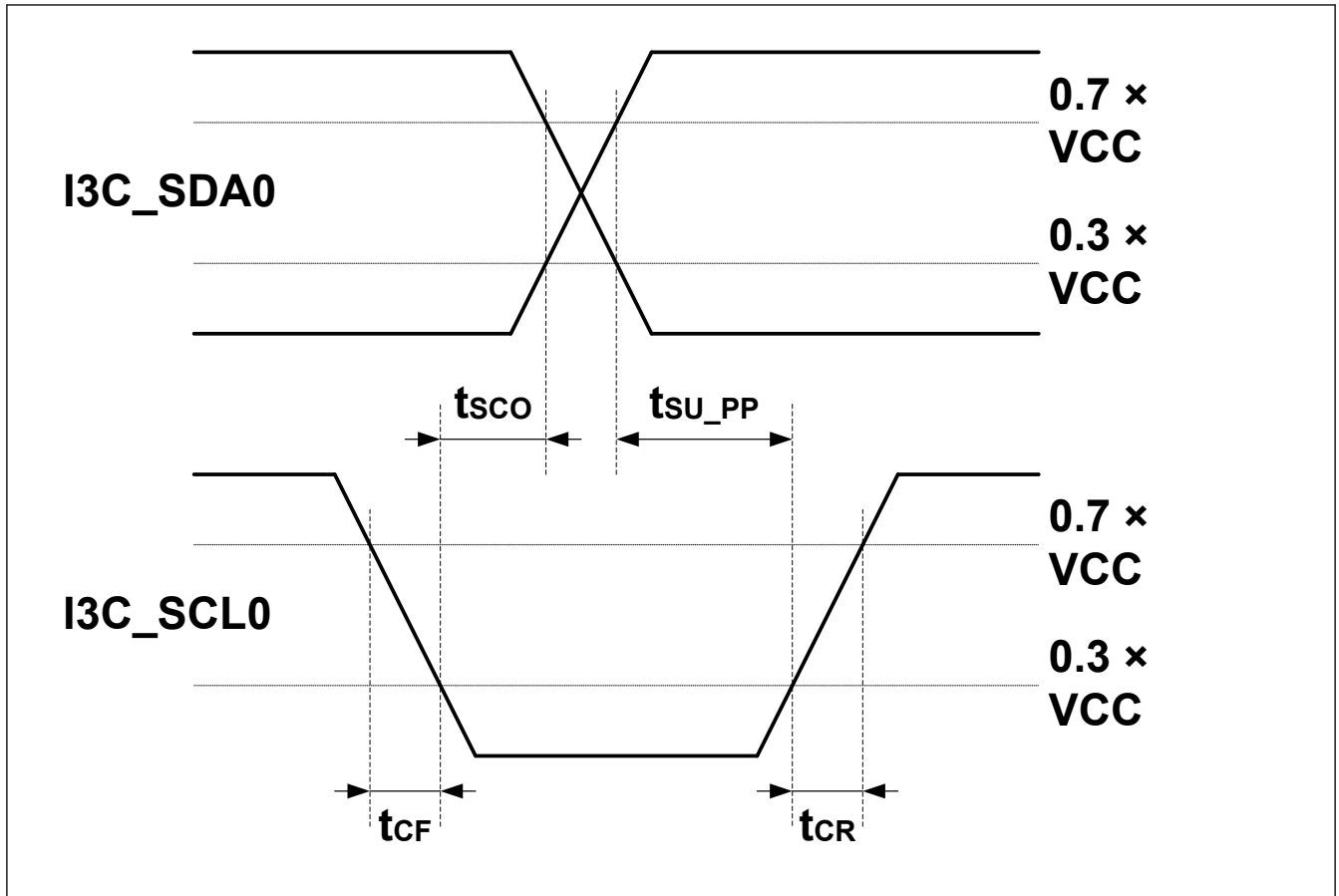

Figure 2.79 I3C Slave Out Timing

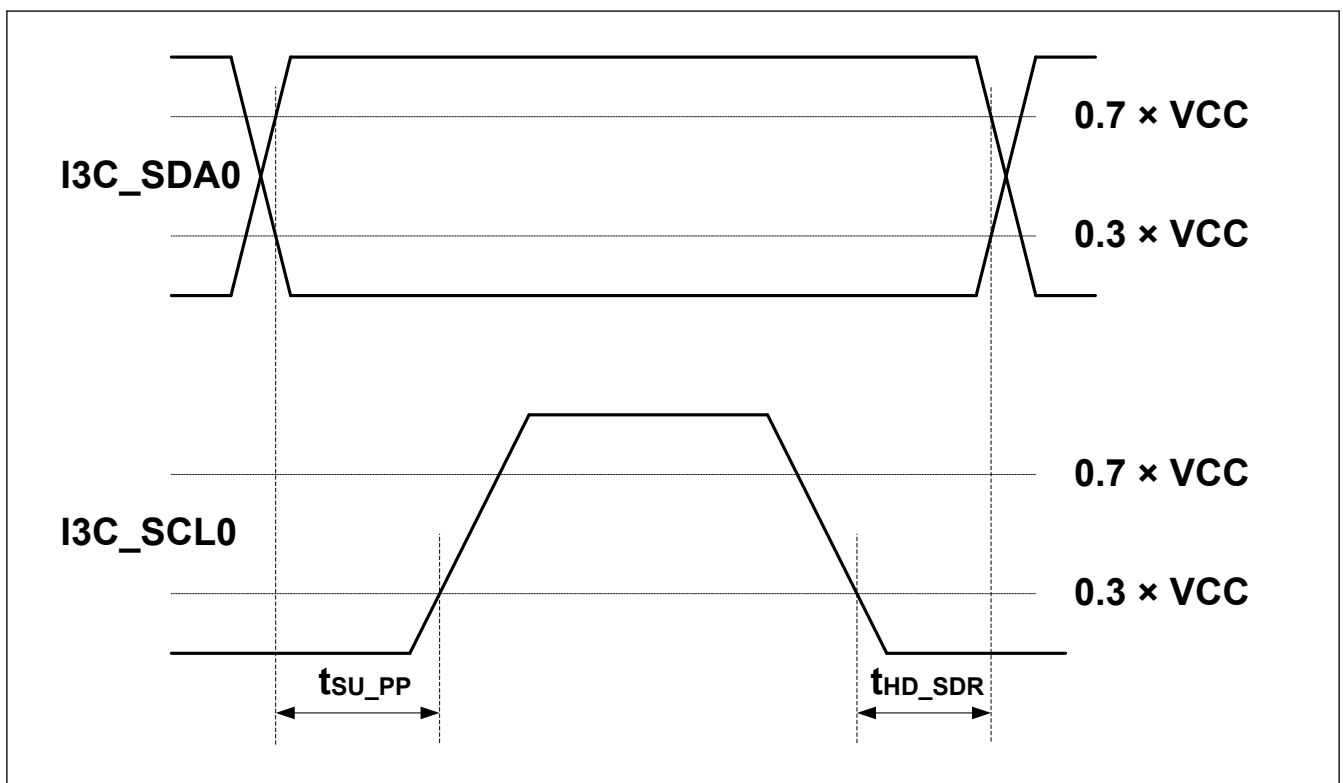

Figure 2.80 Master SDR Timing

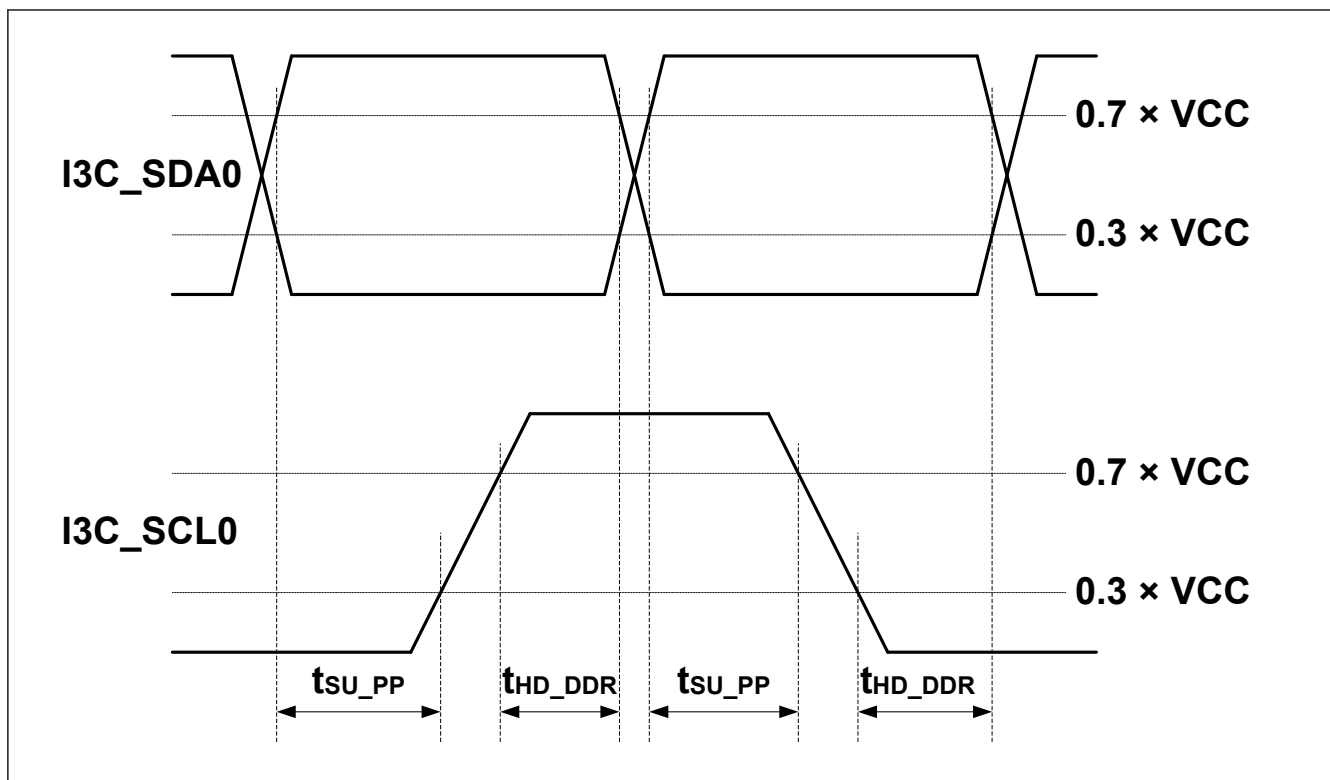

Figure 2.81 Master DDR Timing

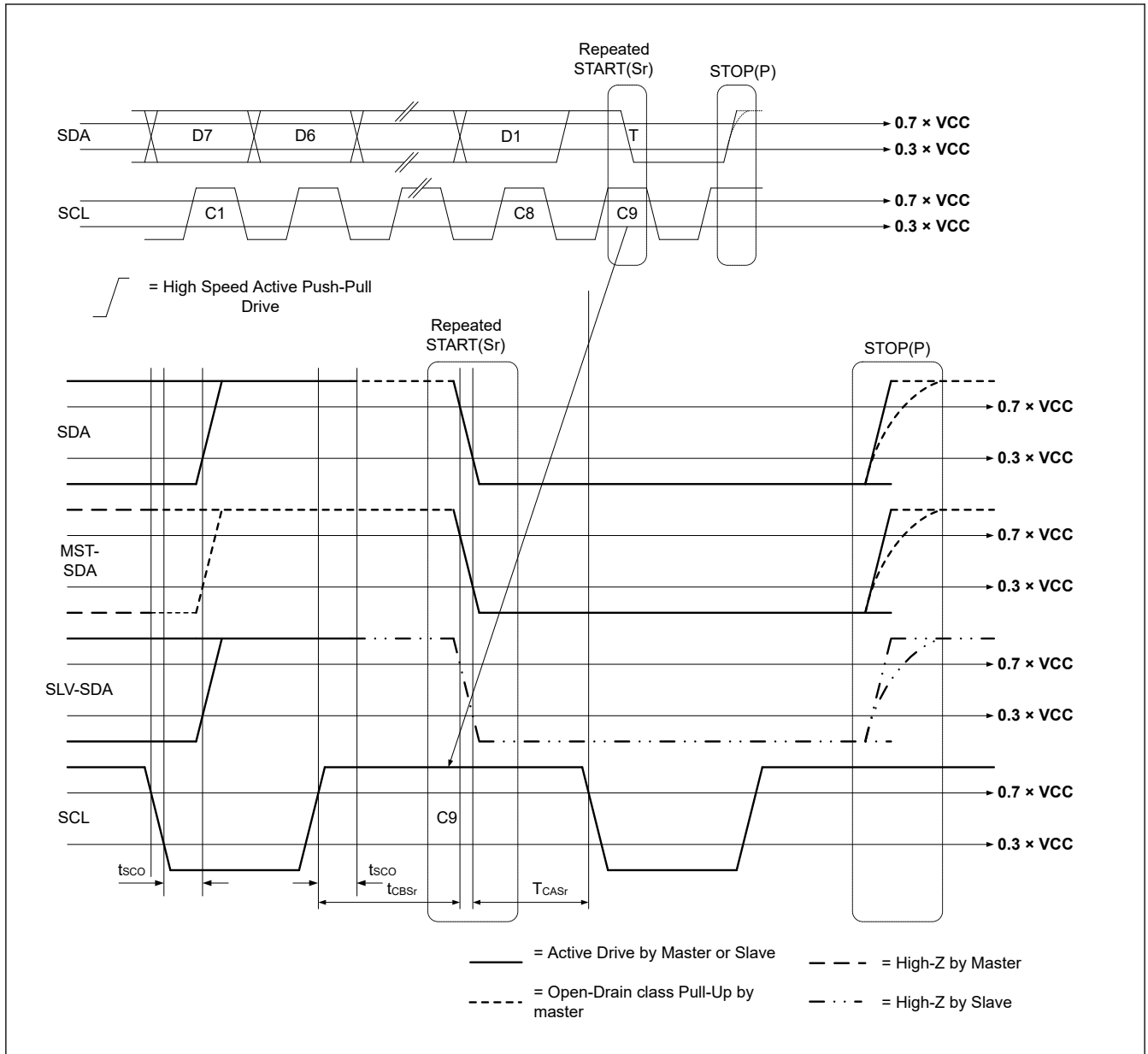

Figure 2.82 T-Bit When Master Ends Read with Repeated START and STOP

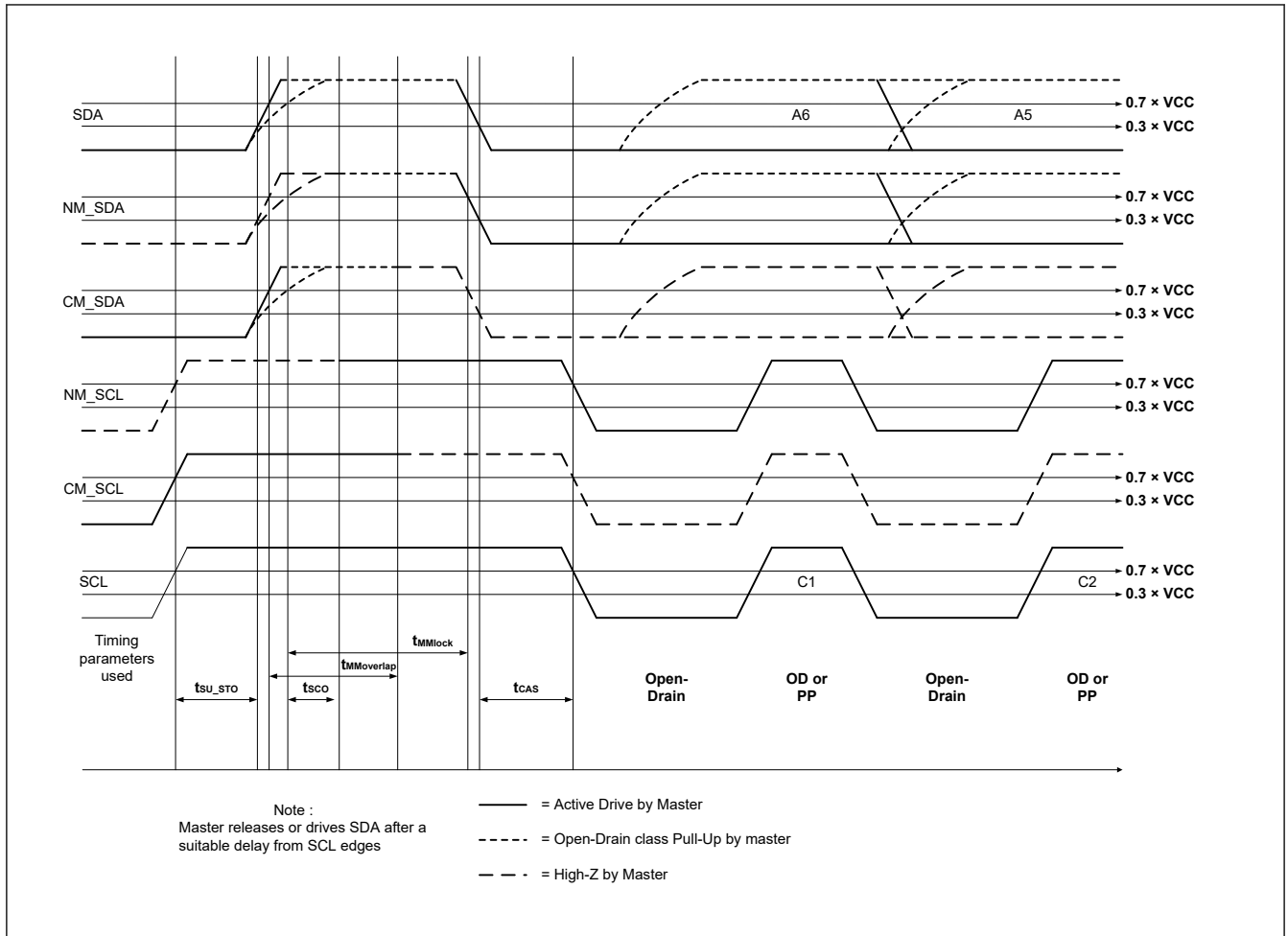

Figure 2.83 Master to Master Bus Handoff

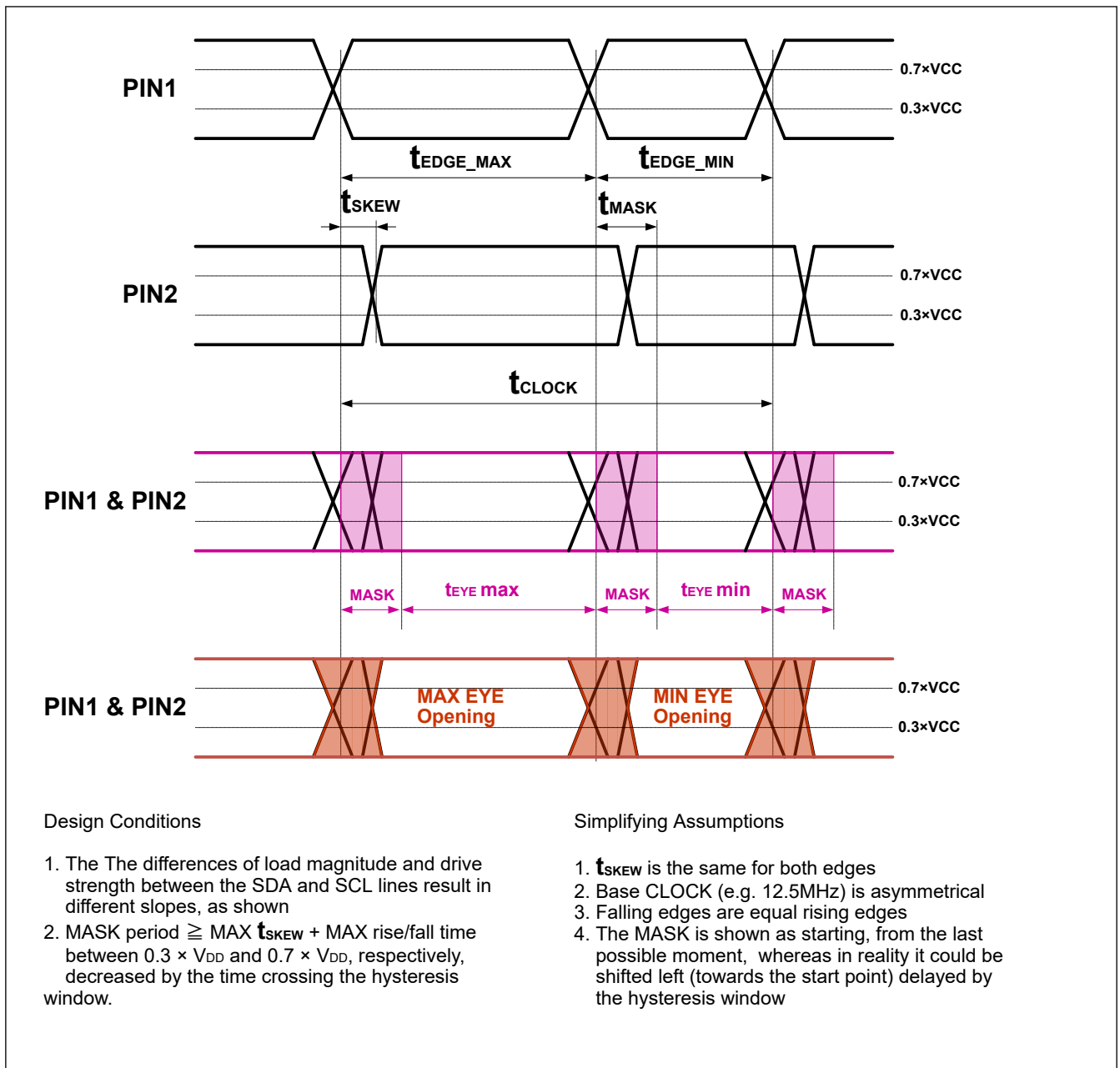

Figure 2.84 Ternary Protocol Timing

2.3.14 SSIE Timing

Table 2.55 SSIE timing (1 of 2)

(1) High drive output is selected with the Port Drive Capability bit in the PmnPFS register.

(2) Use pins that have a letter appended to their names, for instance “_A”, “_B” or “_C” to indicate group membership. For the SSIE interface, the AC portion of the electrical characteristics is measured for each group.

Parameter			Symbol	VCC	Min.	Max.	Unit	Comments
SSIBCK	Cycle	Master	t_O	2.70V or above	80	—	ns	Figure 2.85
				1.68V or above	80	—		
		Slave	t_I	2.70V or above	80	—	ns	
				1.68V or above	80	—		
	High level/ low level	Master	t_{HC}/t_{LC}	2.70V or above	0.35	—	t_O	
				1.68V or above	0.35	—		
		Slave		2.70V or above	0.35	—	t_I	
				1.68V or above	0.35	—		
	Rising time/ falling time	Master	t_{RC}/t_{FC}	2.70V or above	—	0.15	t_O / t_I	
				1.68V or above	—	0.15		
		Slave		2.70V or above	—	0.15	t_O / t_I	
				1.68V or above	—	0.15		

Table 2.55 SSIE timing (2 of 2)

(1) High drive output is selected with the Port Drive Capability bit in the PmnPFS register.

(2) Use pins that have a letter appended to their names, for instance “_A”, “_B” or “_C” to indicate group membership. For the SSIE interface, the AC portion of the electrical characteristics is measured for each group.

Parameter			Symbol	VCC	Min.	Max.	Unit	Comments
SSILRCK0/ SSIFS0, SSITXD0, SSIRXD0	Input set up time	Master	t_{SR}	2.70V or above	12	—	ns	Figure 2.87, Figure 2.88
				1.68V or above	20	—		
		Slave		2.70V or above	12	—	ns	
				1.68V or above	12	—		
	Input hold time	Master	t_{HR}	2.70V or above	8	—	ns	
				1.68V or above	8	—		
		Slave		2.70V or above	15	—	ns	
				1.68V or above	15	—		
	Output delay time	Master	t_{DTR}	2.70V or above	-10	5	ns	
				1.68V or above	-10	7		
		Slave		2.70V or above	0	20	ns	
				1.68V or above	0	25		
Output delay time from SSILRCK/ SSIFS change	Slave	t_{DTRW}	2.70V or above	—	20	ns	Figure 2.89	
			1.68V or above	—	25			
GTIOC2A, AUDIO_CLK	Cycle	t_{EXcyc}	2.70V or above	20	—	ns	Figure 2.86*1	
			1.68V or above	40	—			
	High level/ low level	t_{EXL}/t_{EXH}	2.70V or above	0.4	—	t_{EXcyc}		
			1.68V or above	0.4	—			
	Rising time/ falling time	t_{EXr}/t_{EXf}	2.70V or above	—	0.1*2	t_{EXcyc}		
			1.68V or above	—	0.1*2			

Note 1. For slave-mode transmission, SSIE has a path, through which the signal input from the SSILRCK/SSIFS pin is used to generate transmit data, and the transmit data is logically output to the SSITXD0 or SSIDATA1 pin.

Note 2. 1 μ s at the longest

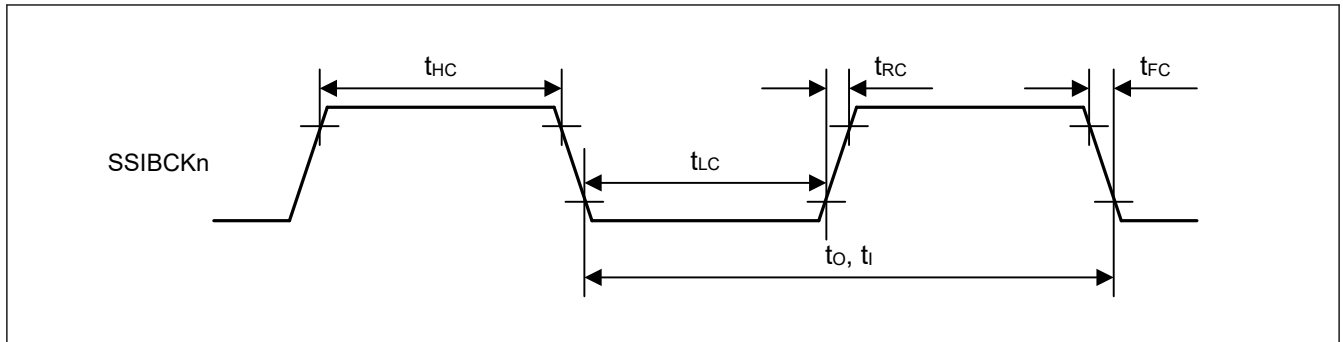

Figure 2.85 SSIE clock input/output timing

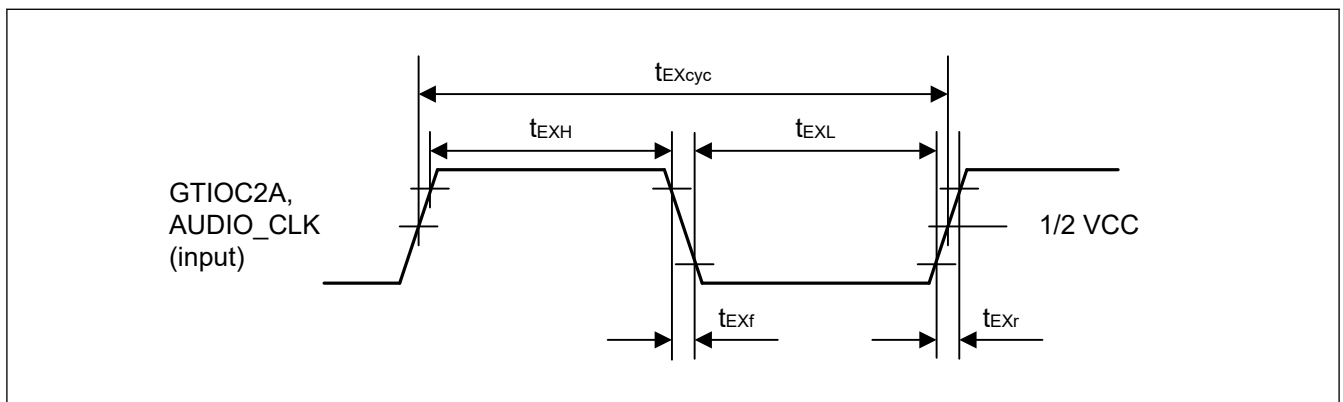

Figure 2.86 Clock input timing

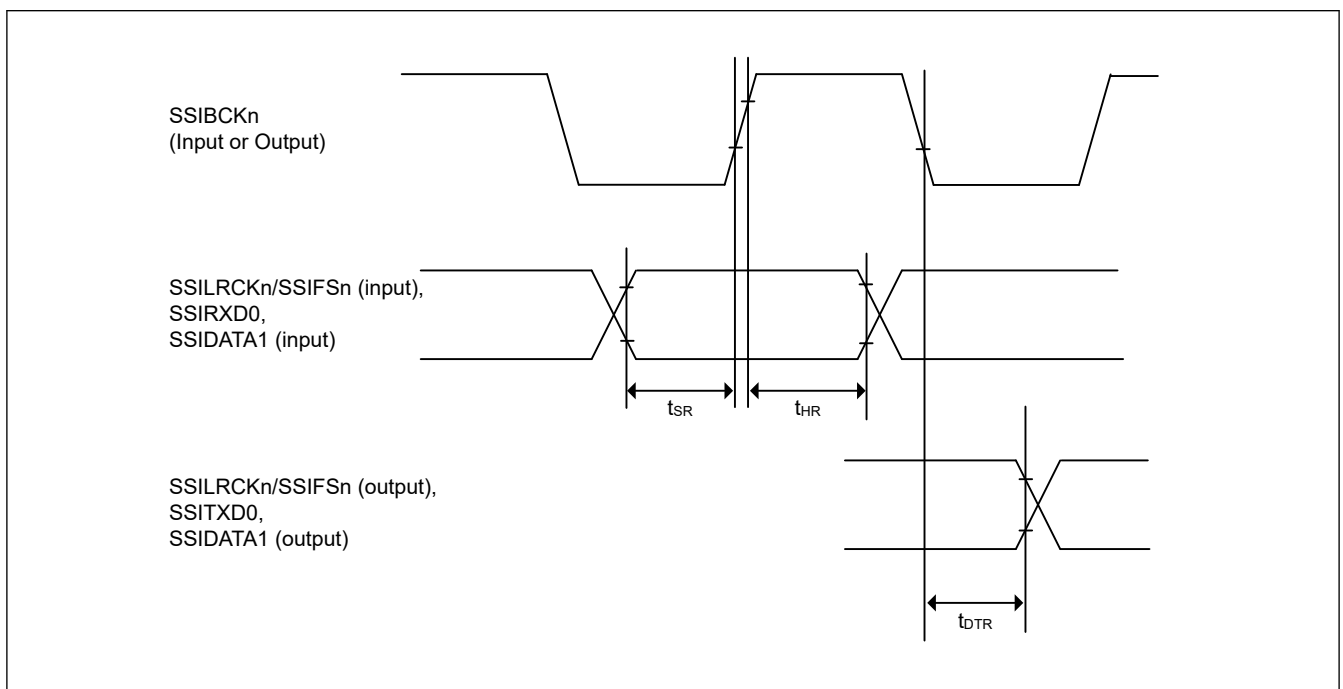

Figure 2.87 SSIE data transmit and receive timing when SSICR.BCKP = 0

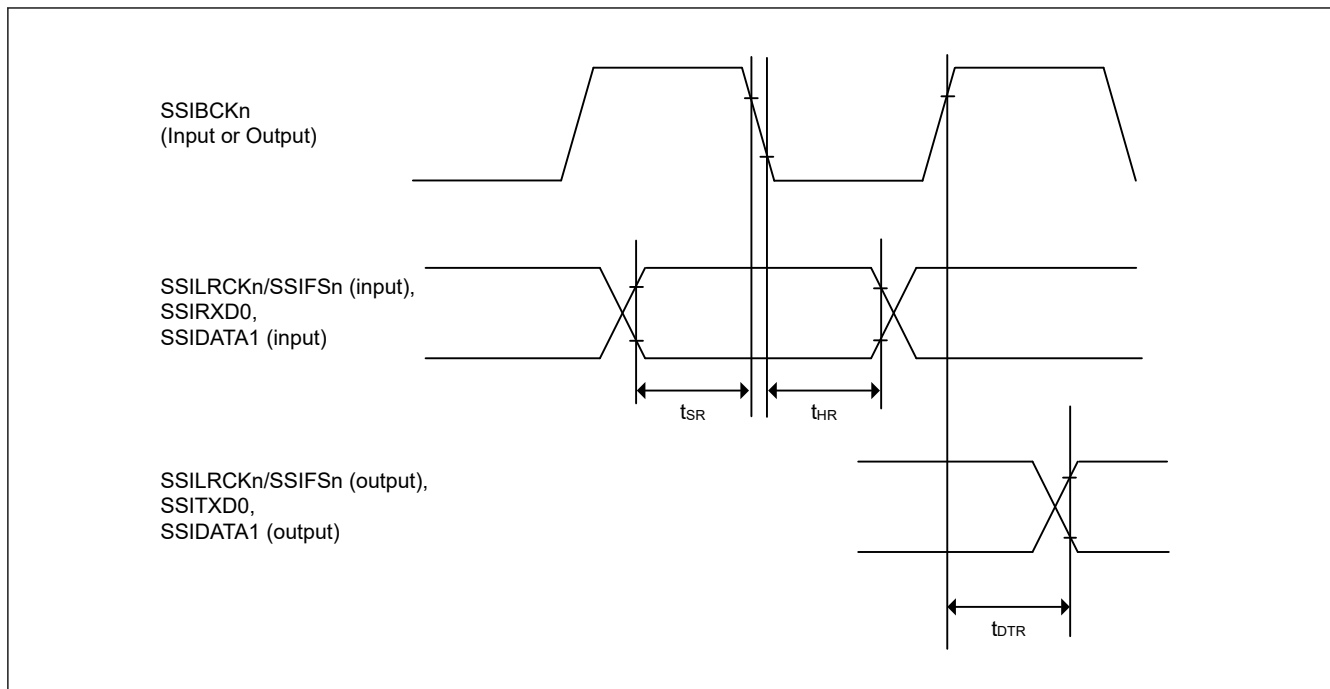

Figure 2.88 SSIE data transmit and receive timing when SSICR.BCKP = 1

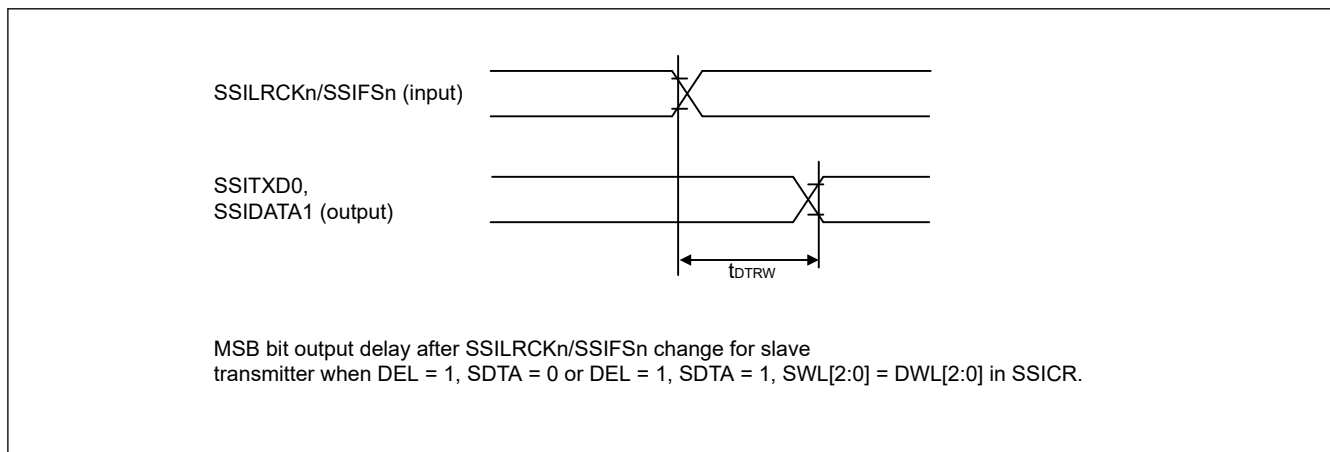

Figure 2.89 SSIE data output delay after SSILRCK0/SSIFS0 change

2.3.15 SD/MMC Host Interface Timing

Table 2.56 SD/MMC Host Interface signal timing

Conditions: High drive output is selected in the Port Drive Capability bit in the PmnPFS register.
High-speed high drive output is selected in specific condition, please see note 1.
Clock duty ratio is 50%.

Parameter	Symbol	VCC/VCC2	Min	Max	Unit	Test conditions
SDCLK clock cycle	t_{SDCYC}	2.70V or above	20	—	ns	Figure 2.90
		1.70 to 1.95V*1	20	—		
		1.70 to 1.95V	40	—		
SDCLK clock high pulse width	t_{SDWH}	2.70V or above	6.5	—	ns	
		1.70 to 1.95V*1	6.5	—		
		1.70 to 1.95V	13.0	—		
SDCLK clock low pulse width	t_{SDWL}	2.70V or above	6.5	—	ns	
		1.70 to 1.95V*1	6.5	—		
		1.70 to 1.95V	13.0	—		
SDCLK clock rise time	t_{SDLH}	2.70V or above	—	3.0	ns	
		1.70 to 1.95V*1	—	4.0		
		1.70 to 1.95V	—	8.0		
SDCLK clock fall time	t_{SDHL}	2.70V or above	—	3.0	ns	
		1.70 to 1.95V*1	—	4.0		
		1.70 to 1.95V	—	8.0		
SDCMD/SDDAT output data delay	t_{SDODLY}	2.70V or above	-7.0	4.0	ns	
		1.70 to 1.95V*1	-7.0	7.0		
		1.70 to 1.95V	-15.0	15.0		
SDCMD/SDDAT input data setup	t_{SDIS}	2.70V or above	4.5	—	ns	
		1.70 to 1.95V*1	4.5	—		
		1.70 to 1.95V	20.0	—		
SDCMD/SDDAT input data hold	t_{SDIH}	2.70V or above	1.5	—	ns	
		1.70 to 1.95V	1.5	—		

Note: Must use pins that have a letter appended to their name, for instance “_A”, “_B”, to indicate group membership. For the SD/MMC Host interface, the AC portion of the electrical characteristics is measured for each group.

Note: If SD1DAT4_A~SD1DAT7_A are used, characteristics above is guaranteed only when VCC = VCC2.

Note 1. Only supported for Ch0 group B (“SD0*_B”) and Ch1 group A (“SD1*_A”)

High-speed high drive output is selected in the port drive capability bit in the PmnPFS register for the following pins:
SD0CLK_B, SD1CLK_A

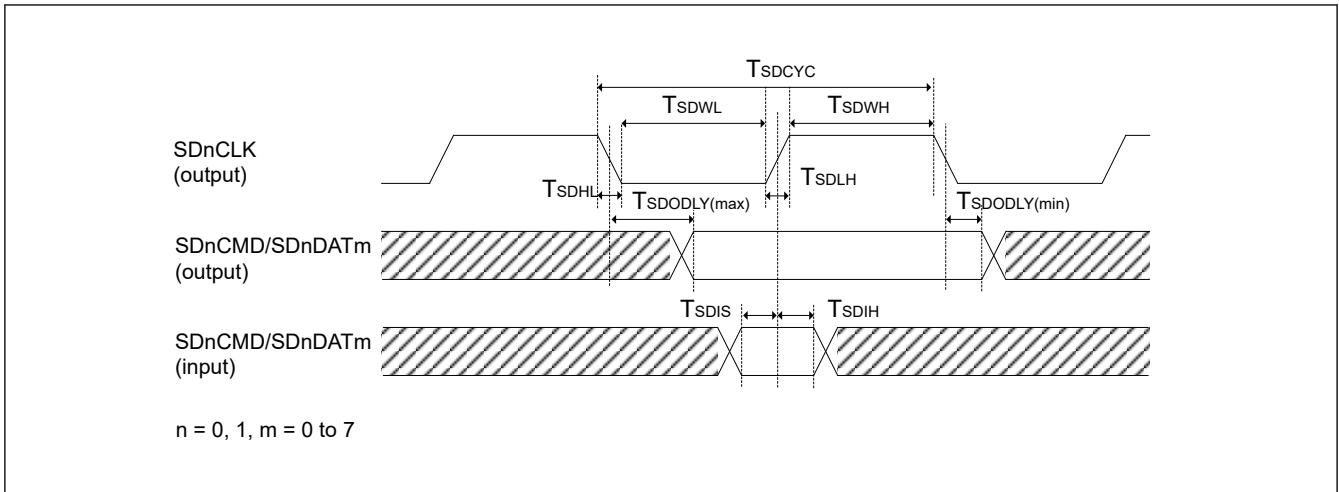

Figure 2.90 SD/MMC Host Interface signal timing

2.3.16 ETHERC Timing

Table 2.57 ETHERC timing

Conditions: ETHERC (RMII): Middle drive output is selected in the Port Drive Capability bit in the PmnPFS register for the following pins: ET0_MDC, ET0_MDIO.

For other pins, high drive output is selected in the Port Drive Capability bit in the PmnPFS register.

ETHERC (MII): Middle drive output is selected in the Port Drive Capability bit in the PmnPFS register.

Parameter	Symbol	VCC	Min	Max	Unit	Test conditions	
ETHERC (RMII)	REF50CK0 cycle time	T_{ck}	2.70V or above	20	—	ns	Figure 2.91 to Figure 2.94
	REF50CK0 frequency, typical 50 MHz	—	—	50 + 100 ppm	MHz		
	REF50CK0 duty	—	35	65	%		
	REF50CK0 rise/fall time	$T_{ckr/ckf}$	0.5	3.5	ns		
	RMII_XXXX ^{*1} output delay	T_{co}	2.5	12.0	ns		
	RMII_XXXX ^{*2} setup time	T_{su}	3	—	ns		
	RMII_XXXX ^{*2} hold time	T_{hd}	1	—	ns		
	RMII_XXXX ^{*1, *2} rise/fall time	T_r/T_f	0.5	5.0	ns		
	ET0_WOL output delay	t_{WOLd}	1	23.5	ns	Figure 2.95	
ETHERC (MII)	ET0_TX_CLK cycle time	t_{Tcyc}	40	—	ns	—	
	ET0_TX_EN output delay	t_{TENd}	1	20	ns	Figure 2.96	
	ET0_ETXD0 to ET_ETXD3 output delay	t_{MTDd}	1	20	ns	Figure 2.97	
	ET0_CRS setup time	t_{CRSs}	10	—	ns		
	ET0_CRS hold time	t_{CRSh}	10	—	ns		
	ET0_COL setup time	t_{COLs}	10	—	ns		
	ET0_COL hold time	t_{COLh}	10	—	ns		
	ET0_RX_CLK cycle time	t_{TRcyc}	40	—	ns		—
	ET0_RX_DV setup time	t_{RDVs}	10	—	ns	Figure 2.98	
	ET0_RX_DV hold time	t_{RDVh}	10	—	ns		
	ET0_ERXD0 to ET_ERXD3 setup time	t_{MRDs}	10	—	ns		
	ET0_ERXD0 to ET_ERXD3 hold time	t_{MRDh}	10	—	ns		
	ET0_RX_ER setup time	t_{RERs}	10	—	ns	Figure 2.99	
	ET0_RX_ER hold time	t_{RESh}	10	—	ns		
	ET0_WOL output delay	t_{WOLd}	1	23.5	ns	Figure 2.100	

Note: The following pins must use pins that have a letter appended to their name, for instance “_A”, “_B”, to indicate group membership. For the ETHERC (RMII) Host interface, the AC portion of the electrical characteristics is measured for each group. REF50CK0_A, REF50CK0_B, RMII0_XXXX_A, RMII0_XXXX_B.

Note 1. RMII_TXD_EN, RMII_TXD1, RMII_TXD0.

Note 2. RMII_CRS_DV, RMII_RXD1, RMII_RXD0, RMII_RX_ER.

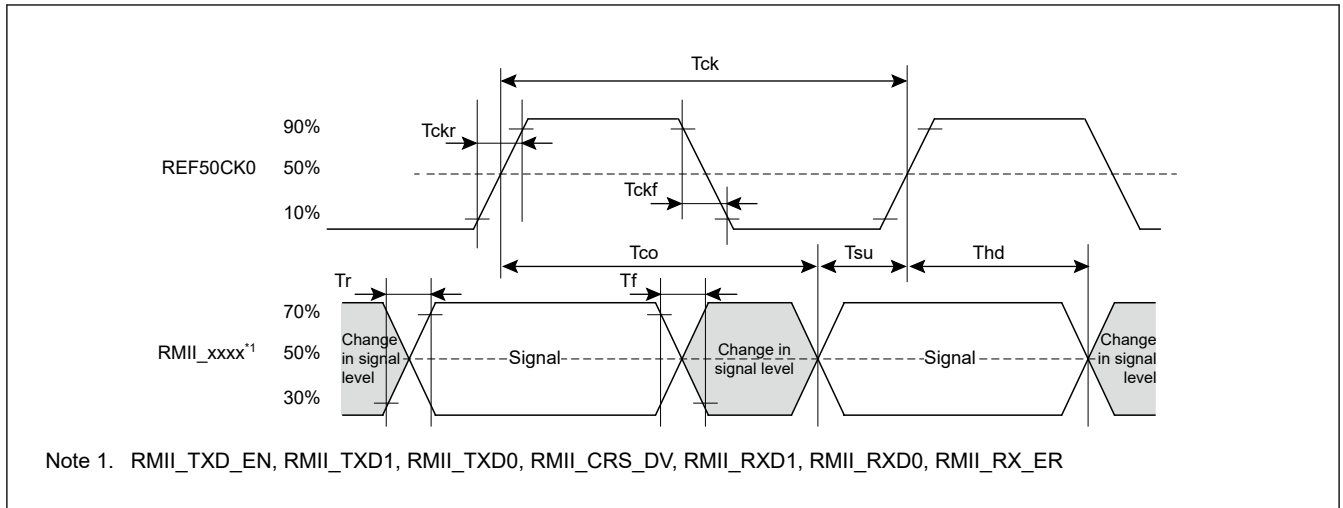

Figure 2.91 REF50CK0 and RMIi signal timing

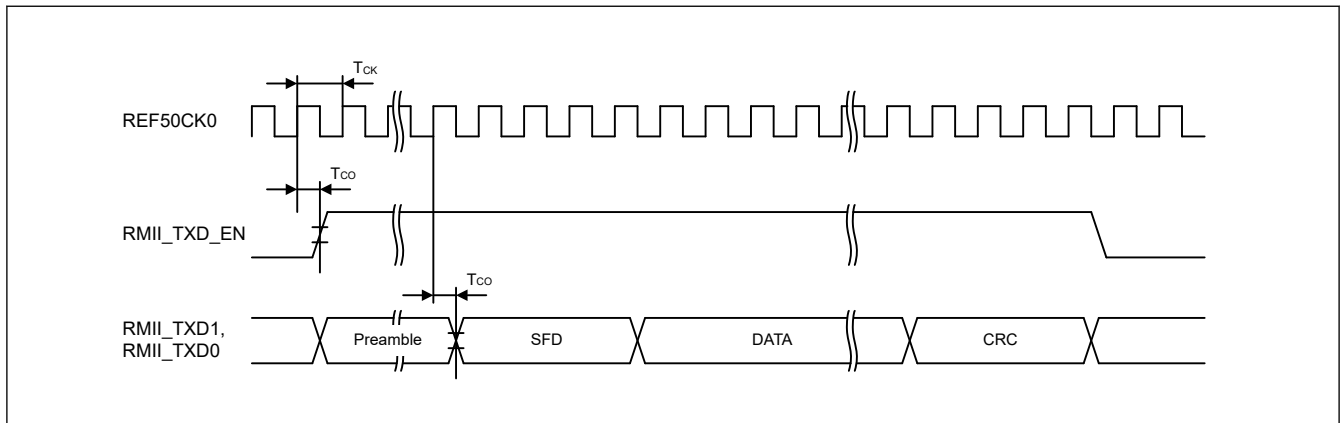

Figure 2.92 RMIi transmission timing

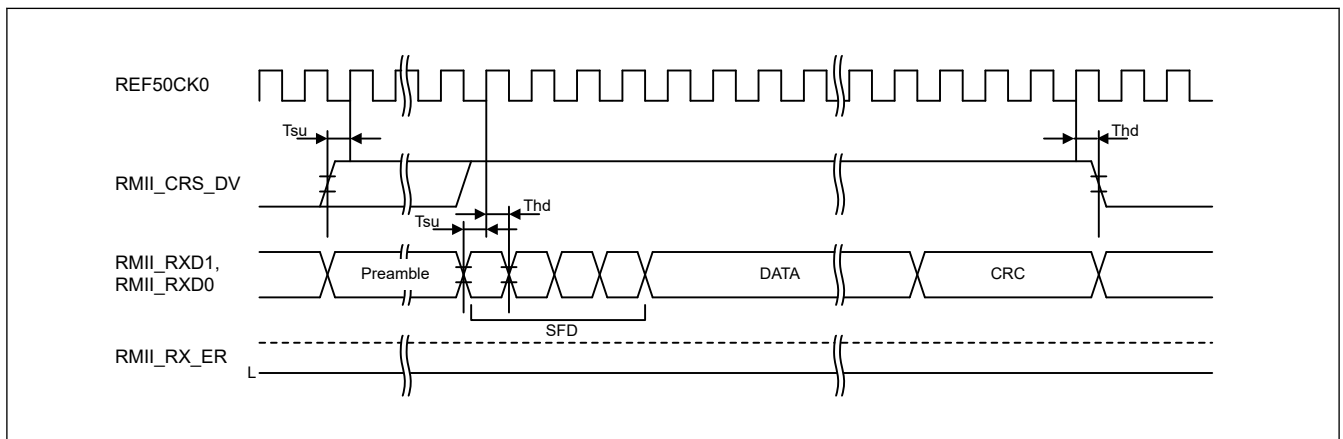

Figure 2.93 RMIi reception timing in normal operation

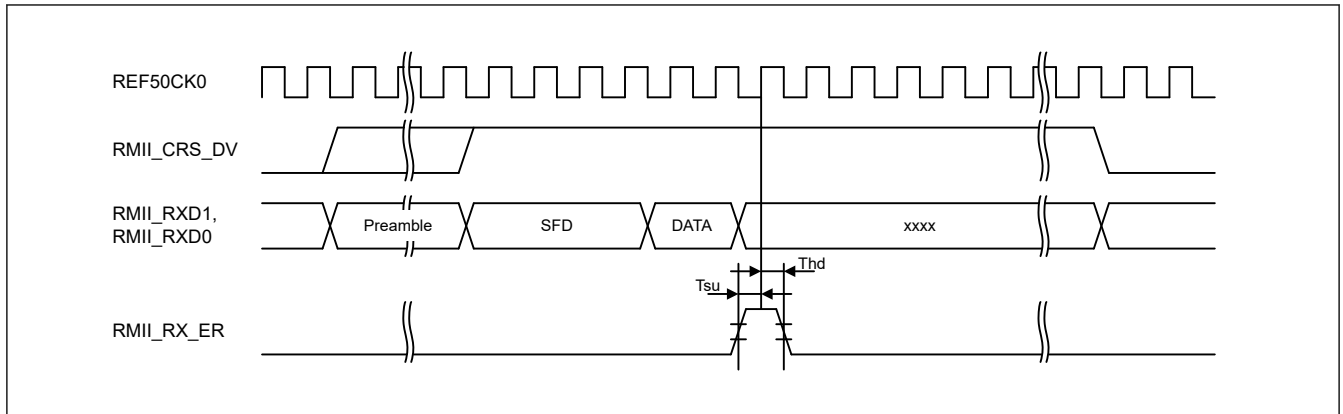

Figure 2.94 RMI reception timing when an error occurs

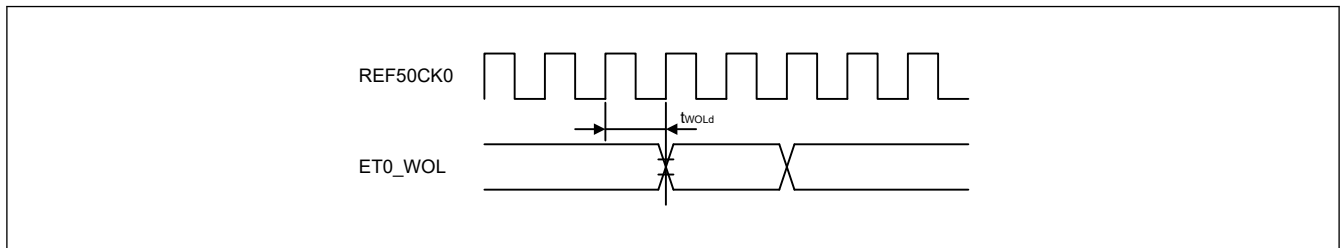

Figure 2.95 WOL output timing for RMI

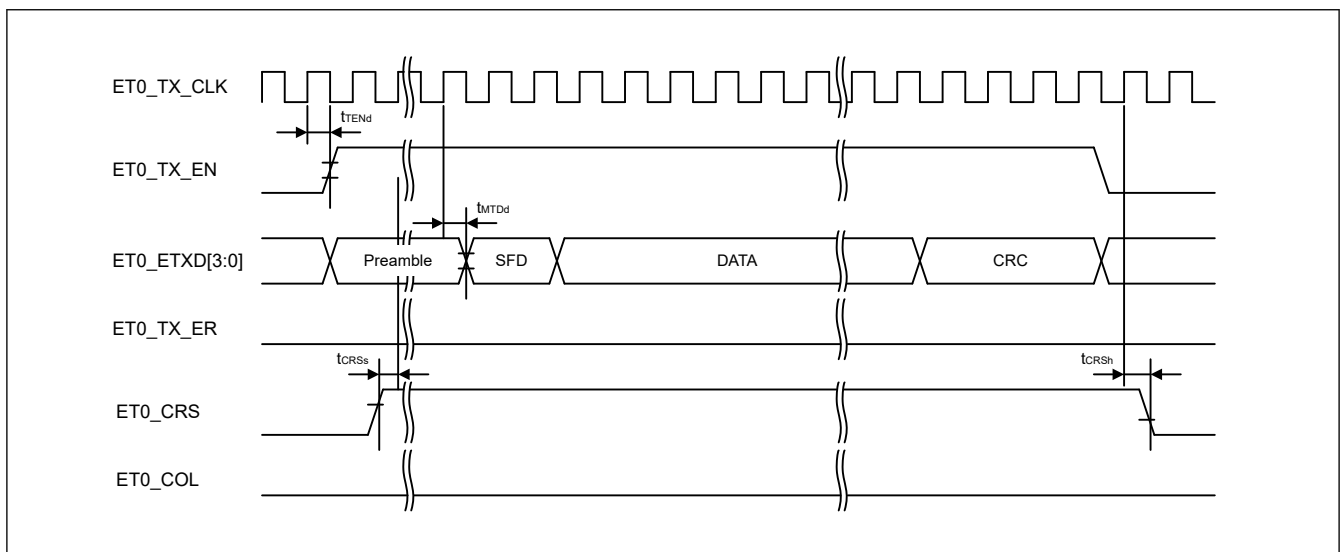

Figure 2.96 MII transmission timing in normal operation

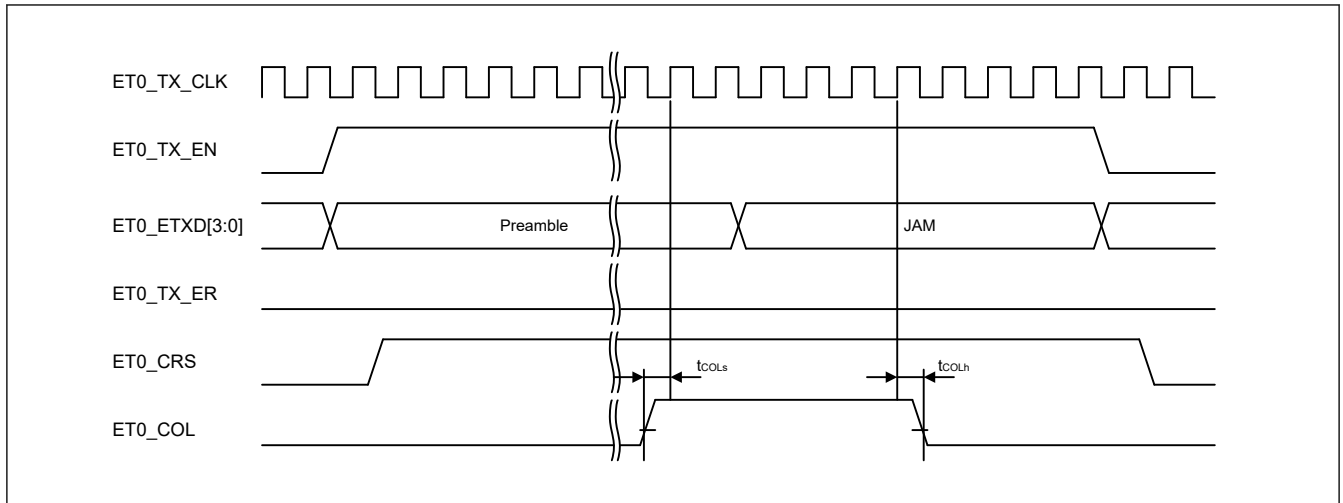

Figure 2.97 MII transmission timing when a conflict occurs

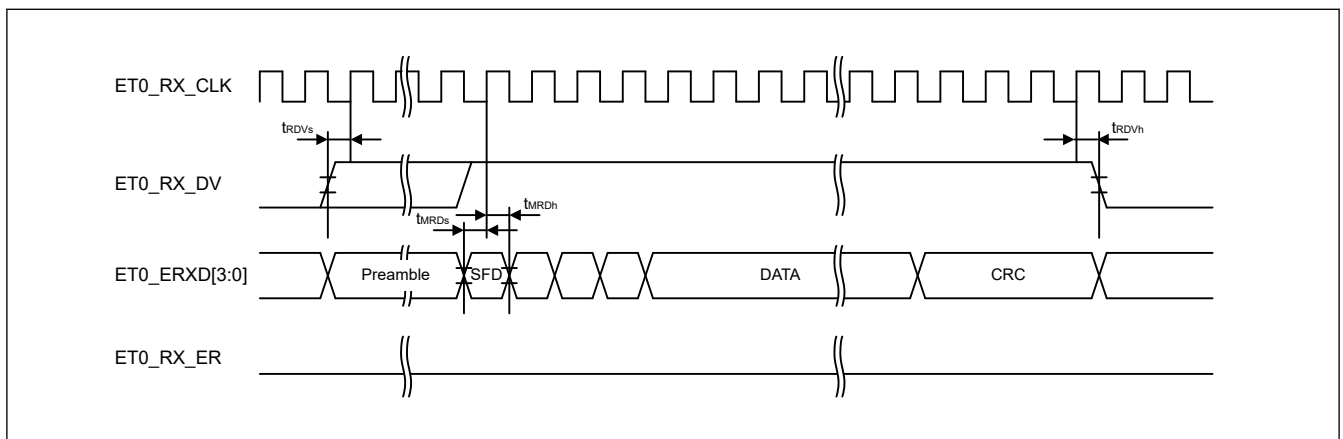

Figure 2.98 MII reception timing in normal operation

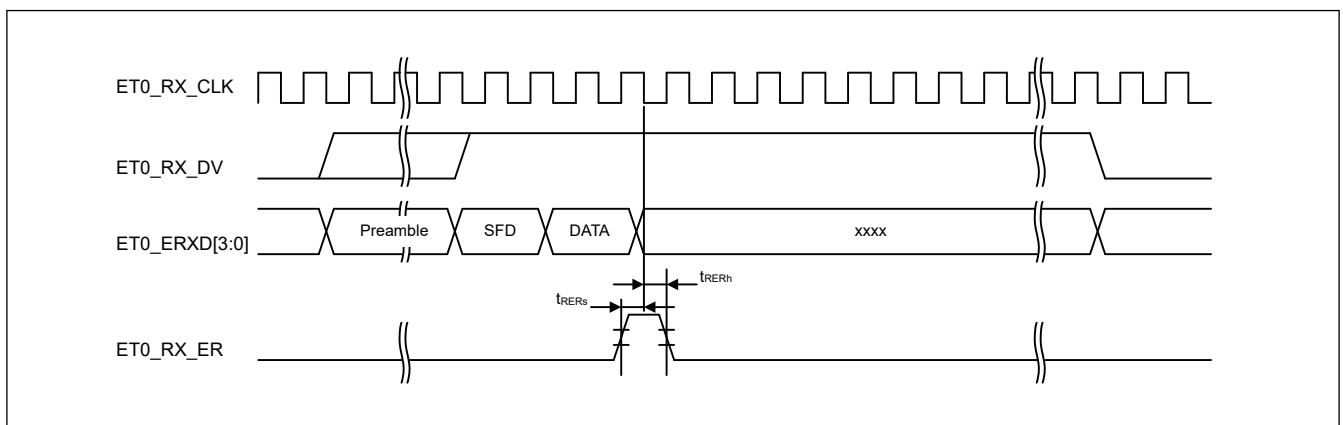

Figure 2.99 MII reception timing when an error occurs

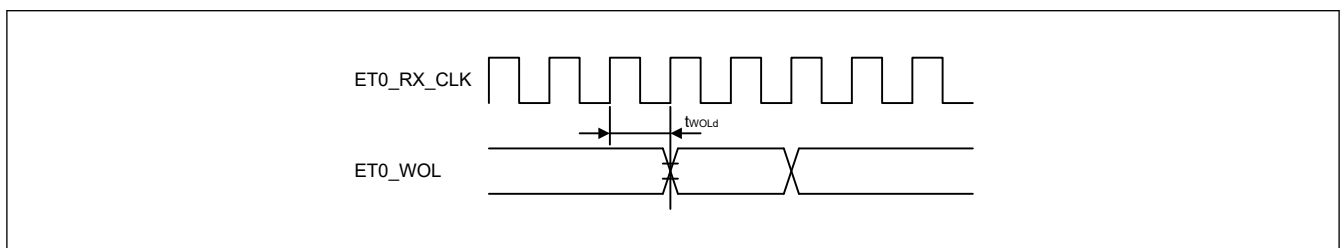

Figure 2.100 WOL output timing for MII

2.3.17 CEU Timing

Table 2.58 Capture Engine Unit Signal Timing

Parameter	Symbol	VCC	Min	Max	Unit	Test conditions
Vertical sync (VIO_VD) setup time (Camera clock rising)	t_{VDS}	2.70 V or above	2.0	—	ns	Figure 2.101 Figure 2.102
		1.68 V or above	4.5	—		
Vertical sync (VIO_VD) setup time (Camera clock falling)	t_{VDS}	2.70 V or above	2.5	—	ns	
		1.68 V or above	4.5	—		
Vertical sync (VIO_VD) hold time	t_{VDH}	2.70 V or above	3.5	—	ns	
		1.68 V or above	5.5	—		
Horizontal sync (VIO_HD) setup time (Camera clock rising)	t_{HDS}	2.70 V or above	2.0	—	ns	
		1.68 V or above	4.5	—		
Horizontal sync (VIO_HD) setup time (Camera clock falling)	t_{HDS}	2.70 V or above	2.5	—	ns	
		1.68 V or above	4.5	—		
Horizontal sync (VIO_HD) hold time	t_{HHD}	2.70 V or above	3.5	—	ns	
		1.68 V or above	5.5	—		
Capture image data (VIO_D) setup time (Camera clock rising)	t_{DTS}	2.70 V or above	2.0	—	ns	
		1.68 V or above	4.5	—		
Capture image data (VIO_D) setup time (Camera clock falling)	t_{DTS}	2.70 V or above	2.5	—	ns	
		1.68 V or above	4.5	—		
Capture image data (VIO_D) hold time	t_{DTH}	2.70 V or above	3.5	—	ns	
		1.68 V or above	5.5	—		
Camera clock cycle	t_{VCYC}	2.70 V or above	11.5	—	ns	
		1.68 V or above	23.0	—		
Camera clock high level width	t_{VHW}	2.70 V or above	$0.4 \times t_{VCYC}$	—	ns	
		1.68 V or above	$0.4 \times t_{VCYC}$	—		
Camera clock low level width	t_{VLW}	2.70 V or above	$0.4 \times t_{VCYC}$	—	ns	
		1.68 V or above	$0.4 \times t_{VCYC}$	—		
Field identification signal (VIO_FLD) setup time (Camera clock rising)	t_{VFDS}	2.70 V or above	2.0	—	ns	
		1.68 V or above	4.5	—		
Field identification signal (VIO_FLD) setup time (Camera clock falling)	t_{VFDS}	2.70 V or above	2.5	—	ns	
		1.68 V or above	4.5	—		
Field identification signal (VIO_FLD) hold time	t_{VFDH}	2.70 V or above	3.5	—	ns	
		1.68 V or above	5.5	—		

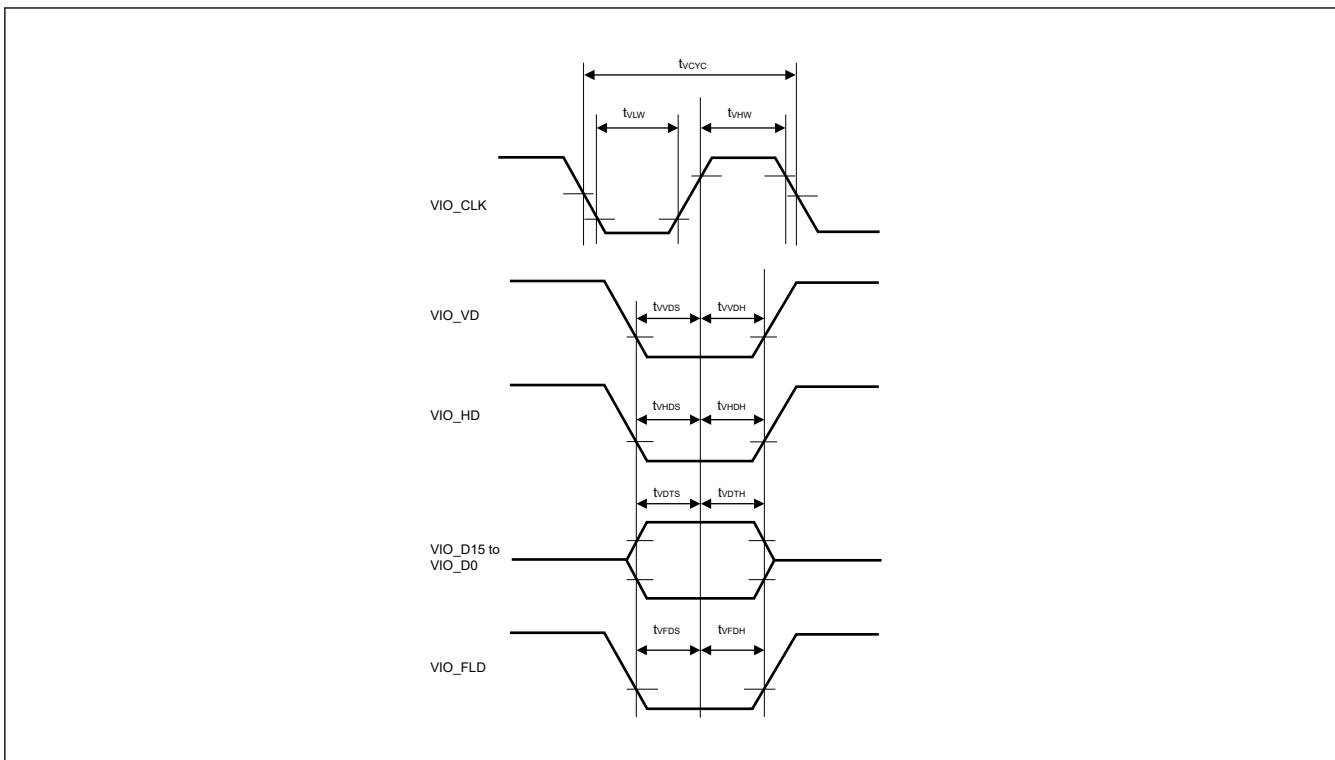

Figure 2.101 Capture Engine Unit Module Signal Timing of data capturing on the rising edge of VIO_CLK

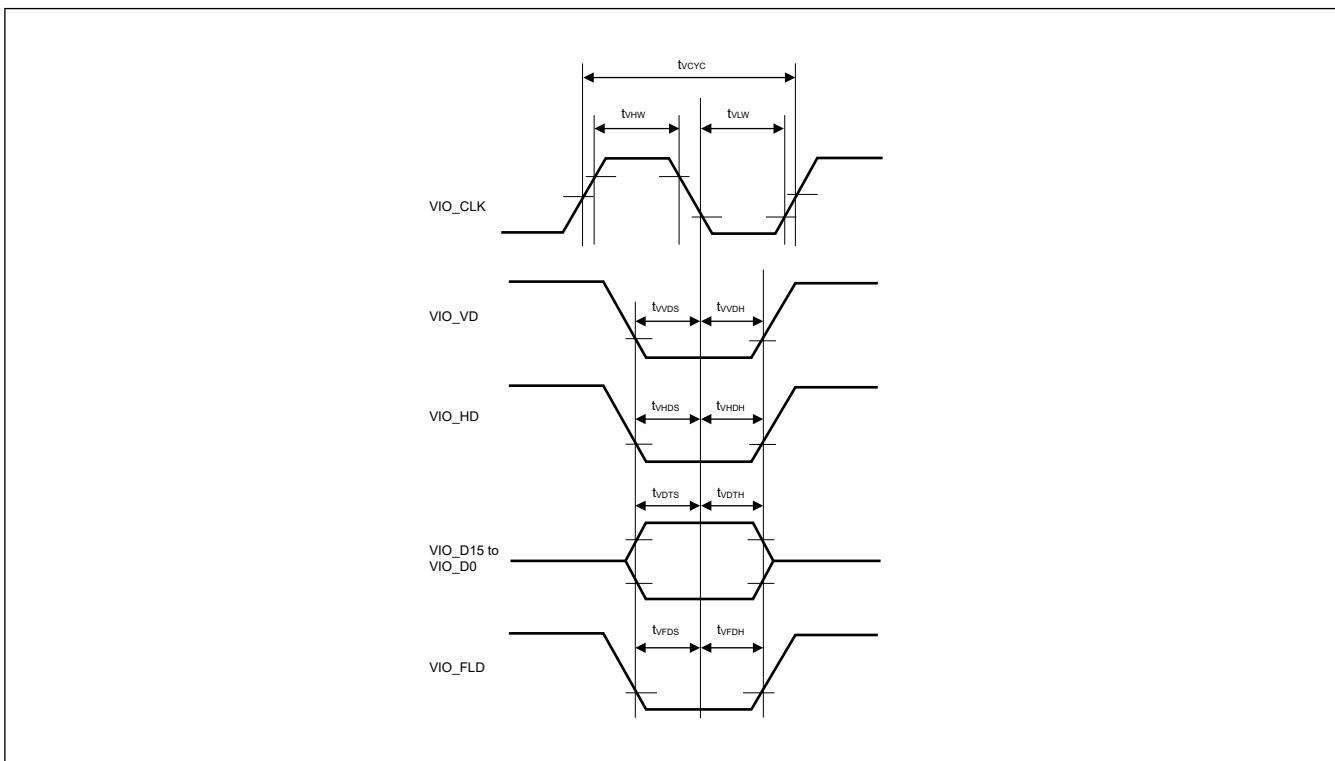

Figure 2.102 Capture Engine Unit Module Signal Timing of data capturing on the falling edge of VIO_CLK

2.3.18 GLCDC Timing

Table 2.59 GLCDC Timing

Conditions:

LCD_CLK: High drive output is selected in the port drive capability bit in the PmnPFS register.

LCD_DATA: Middle drive output is selected in the port drive capability bit in the PmnPFS register.

Parameter	Symbol	VCC	Min	Max	Units	Test conditions
LCD_EXTCLK input clock frequency	$t_{E_{cyc}}$	2.70 V or above	—	60* ¹	MHz	Figure 2.103
		1.68 V or above	—	30		
LCD_EXTCLK input clock low pulse width	t_{WL}	2.70 V or above	0.45	—	$t_{E_{cyc}}$	
		1.68 V or above	0.45	—		
LCD_EXTCLK input clock high pulse width	t_{WH}	2.70 V or above	0.45	—	$t_{E_{cyc}}$	
		1.68 V or above	0.45	—		
LCD_CLK output clock frequency	$1/t_{L_{cyc}}$	2.70 V or above	—	60* ¹	MHz	Figure 2.104
		1.68 V or above	—	30		
LCD_CLK output clock low pulse width	t_{LOL}	2.70 V or above	0.4	0.6	$t_{L_{cyc}}$	
		1.68 V or above	0.4	0.6		
LCD_CLK output clock high pulse width	t_{LOH}	2.70 V or above	0.4	0.6	$t_{L_{cyc}}$	
		1.68 V or above	0.4	0.6		
LCD data output delay timing	_A or _B combinations* ²	2.70 V or above	-3.5	4.0	ns	Figure 2.105
		1.68 V or above	-5.5	6.0		
	_A and _B combinations* ³	2.70 V or above	-5.0	5.5		
		1.68 V or above	-7.0	7.5		

Note 1. Parallel RGB888, 666, 565: Maximum 54 MHz
 Serial RGB888: Maximum 60 MHz (4x speed)

Note 2. Use pins that have a letter appended to their names, for instance, “_A” or “_B”, to indicate.

Note 3. Pins of group “_A” and “_B” combinations are used.

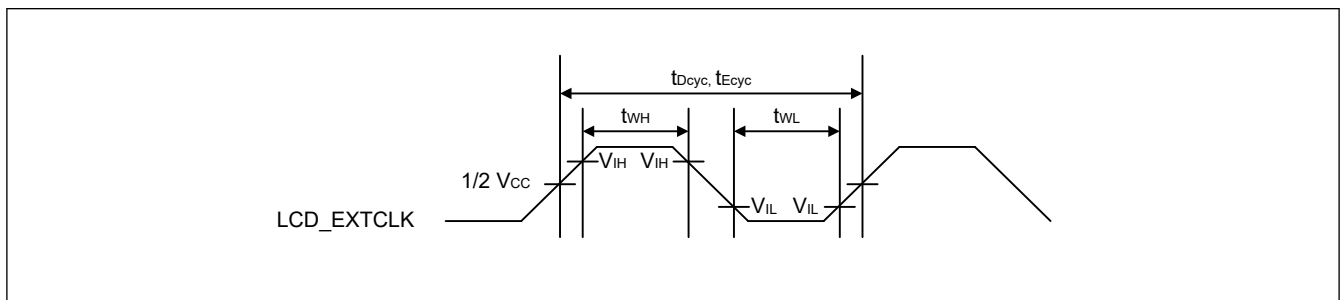

Figure 2.103 LCD_EXTCLK clock timing

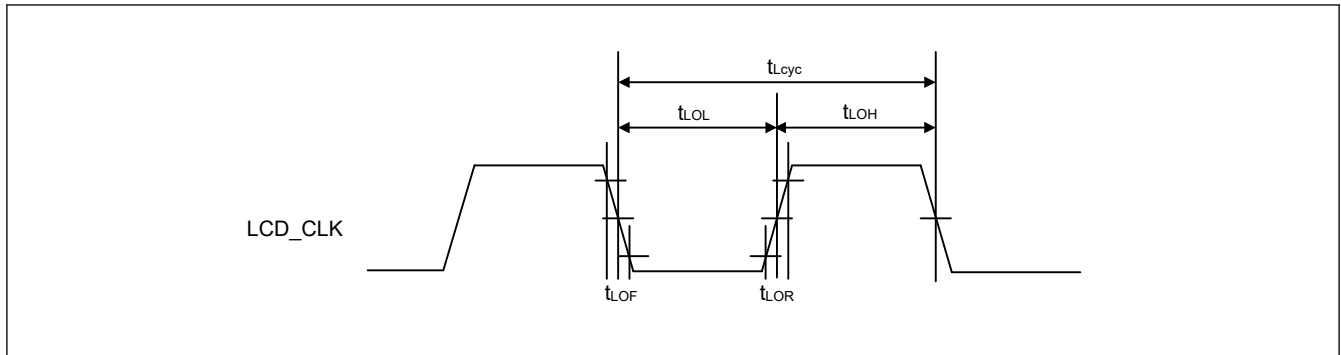

Figure 2.104 LCD_CLK clock output timing

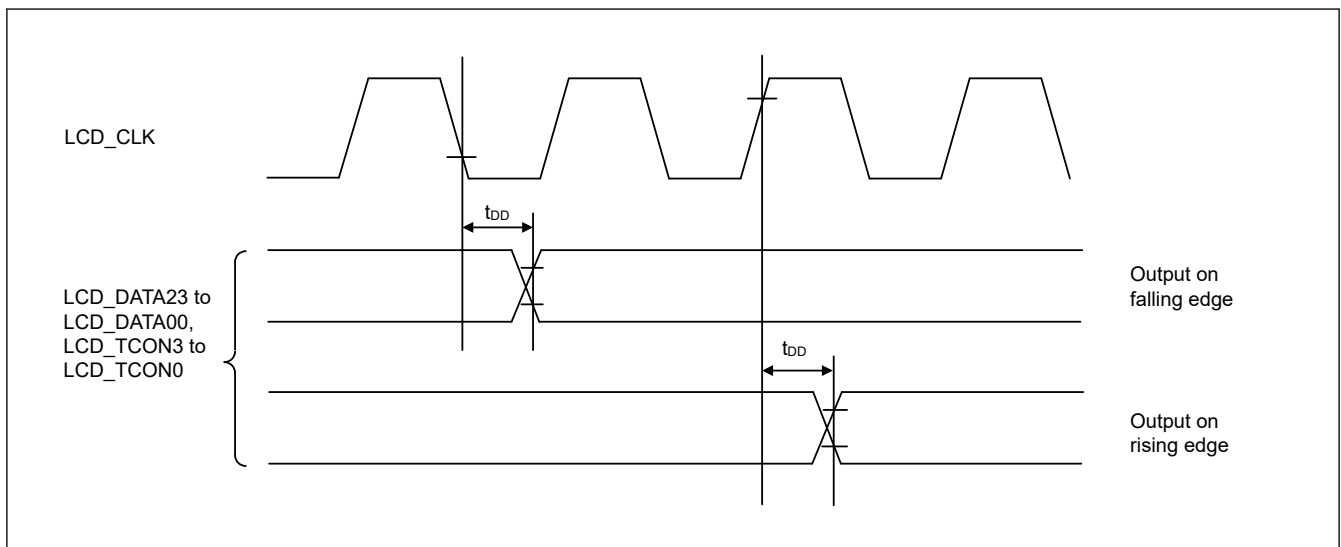

Figure 2.105 Display output timing

2.3.19 CANFD Timing

Table 2.60 CANFD interface timing

Parameter	Symbol	VCC/VCC2	Min	Max	Unit	Test conditions
Internal delay time	t_{node}	2.70 V or above	—	50	ns	Figure 2.106
		1.68 V or above (VCC) 1.65 V or above (VCC2)	—	50		
Transmission rate		2.70 V or above	—	8	Mbps	
		1.68 V or above (VCC) 1.65 V or above (VCC2)	—	8		

Note: Internal delay time (t_{node}) = Internal transfer delay time (t_{output}) + Internal receive delay time (t_{input})

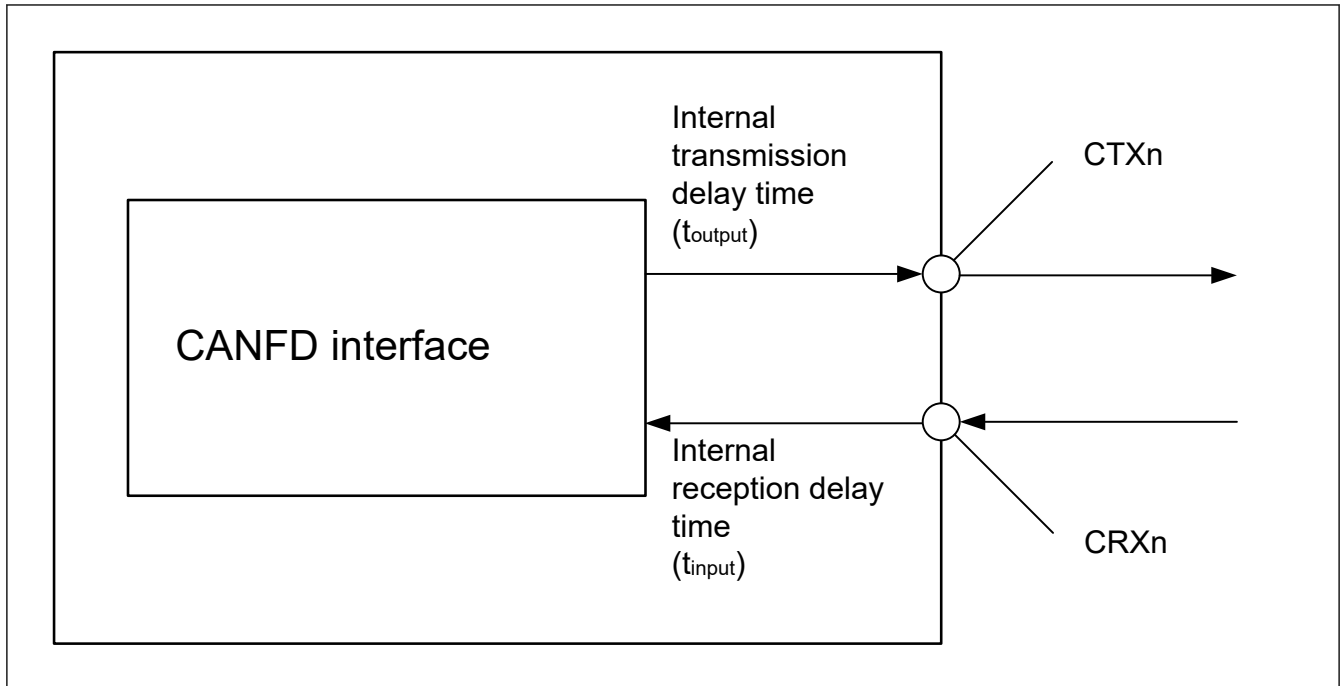

Figure 2.106 CANFD interface condition

2.4 USB Characteristics

2.4.1 USBFS Timing

Table 2.61 USBFS low-speed characteristics for host only (USB_DP and USB_DM pin characteristics)

Conditions: VCC = VCC_USB = 3.0 to 3.6 V, USBCLK = 48 MHz

Parameter	Symbol	Min	Typ	Max	Unit	Test conditions	
Input characteristics	Input high voltage	V _{IH}	2.0	—	—	V	—
	Input low voltage	V _{IL}	—	—	0.8	V	—
	Differential input sensitivity	V _{DI}	0.2	—	—	V	USB_DP - USB_DM
	Differential common-mode range	V _{CM}	0.8	—	2.5	V	—
Output characteristics	Output high voltage	V _{OH}	2.8	—	3.6	V	I _{OH} = -200 μA
	Output low voltage	V _{OL}	0.0	—	0.3	V	I _{OL} = 2 mA
	Cross-over voltage	V _{CRS}	1.3	—	2.0	V	Figure 2.107
	Rise time	t _{LR}	75	—	300	ns	
	Fall time	t _{LF}	75	—	300	ns	
	Rise/fall time ratio	t _{LR} / t _{LF}	80	—	125	%	t _{LR} / t _{LF}
Pull-up and pull-down characteristics	USB_DP and USB_DM pull-down resistance in host controller mode	R _{pd}	14.25	—	24.80	kΩ	—

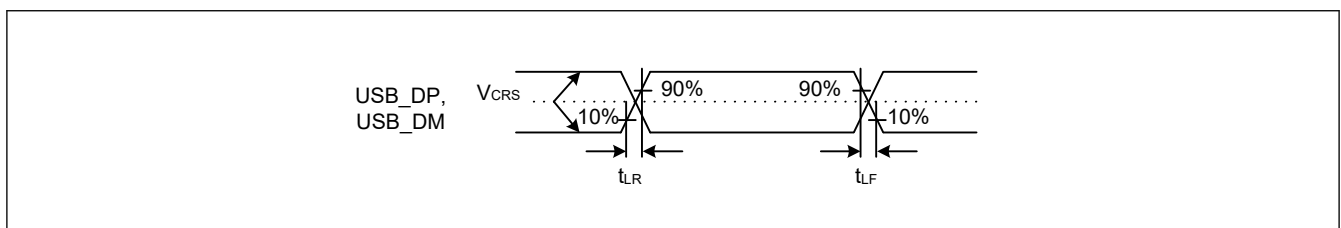

Figure 2.107 USB_DP and USB_DM output timing in low-speed mode

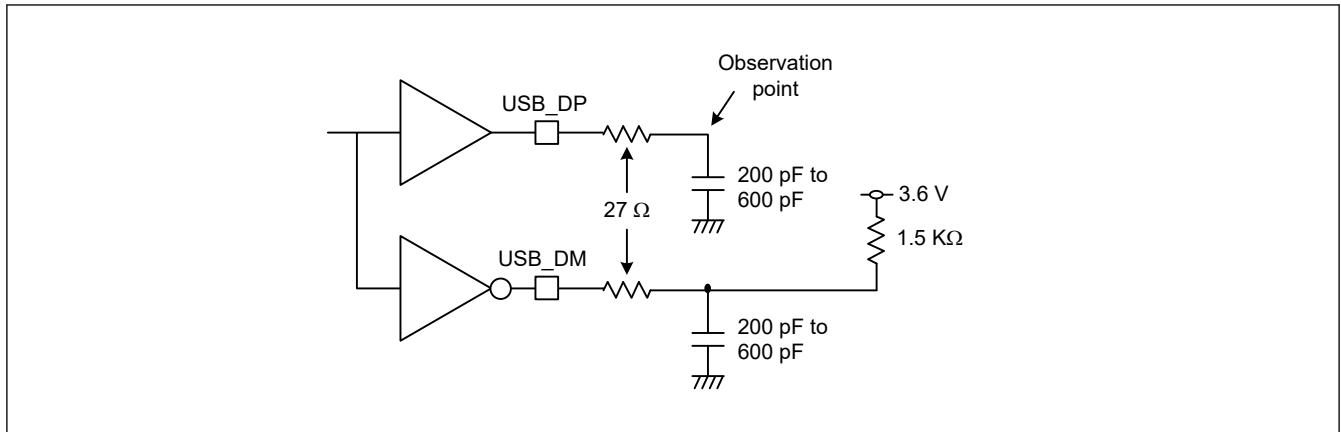

Figure 2.108 Test circuit in low-speed mode

Table 2.62 USBFS full-speed characteristics (USB_DP and USB_DM pin characteristics)

Conditions: VCC = VCC_USB = 3.0 to 3.6 V, USBCLK = 48 MHz

Parameter	Symbol	Min	Typ	Max	Unit	Test conditions	
Input characteristics	Input high voltage	V _{IH}	2.0	—	—	V	—
	Input low voltage	V _{IL}	—	—	0.8	V	—
	Differential input sensitivity	V _{DI}	0.2	—	—	V	USB_DP - USB_DM
	Differential common-mode range	V _{CM}	0.8	—	2.5	V	—
Output characteristics	Output high voltage	V _{OH}	2.8	—	3.6	V	I _{OH} = -200 μA
	Output low voltage	V _{OL}	0.0	—	0.3	V	I _{OL} = 2 mA
	Cross-over voltage	V _{CRS}	1.3	—	2.0	V	Figure 2.109
	Rise time	t _{LR}	4	—	20	ns	t _{FR} / t _{FF}
	Fall time	t _{LF}	4	—	20	ns	
	Rise/fall time ratio	t _{LR} / t _{LF}	90	—	111.11	%	
	Output resistance	Z _{DRV}	28	—	44	Ω	USBFS: R _s = 27 Ω included
Pull-up and pull-down characteristics	DM pull-up resistance in device controller mode	R _{pu}	0.900	—	1.575	kΩ	During idle state
		R _{pu}	1.425	—	3.090	kΩ	During transmission and reception
	USB_DP and USB_DM pull-down resistance in host controller mode	R _{pd}	14.25	—	24.80	kΩ	—

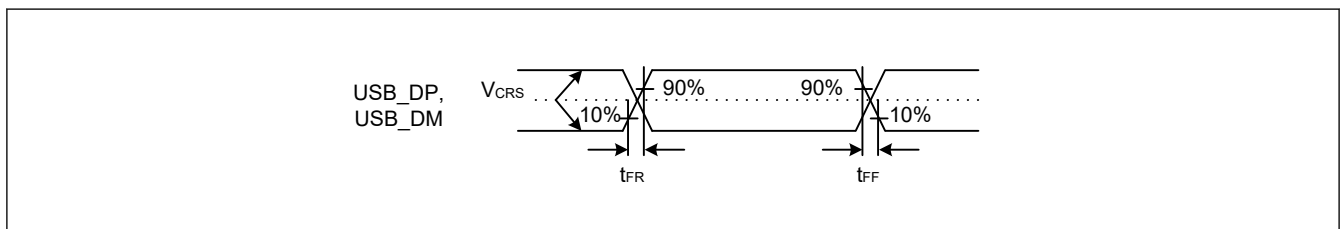

Figure 2.109 USB_DP and USB_DM output timing in full-speed mode

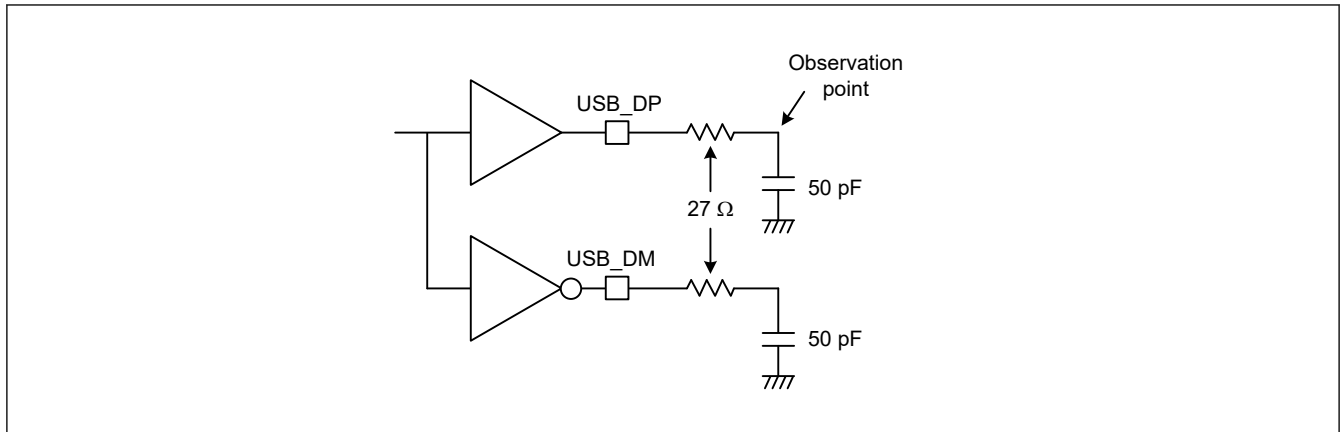

Figure 2.110 Test circuit in full-speed mode

2.4.2 USBHS Timing

Table 2.63 USBHS low-speed characteristics for host only (USB_DP and USB_DM pin characteristics)

Conditions: USBHS_RREF = 2.2 kΩ ± 1%, USBMCLK = 12/20/24/48 MHz, USBCLK = 48MHz, USB60CLK = 60MHz

Parameter	Symbol	Min	Typ	Max	Unit	Test conditions	
Input characteristics	Input high voltage	V_{IH}	2.0	—	—	V	—
	Input low voltage	V_{IL}	—	—	0.8	V	—
	Differential input sensitivity	V_{DI}	0.2	—	—	V	USB_DP - USB_DM
	Differential common-mode range	V_{CM}	0.8	—	2.5	V	—
Output characteristics	Output high voltage	V_{OH}	2.8	—	3.6	V	$I_{OH} = -200 \mu A$
	Output low voltage	V_{OL}	0.0	—	0.3	V	$I_{OL} = 2 \text{ mA}$
	Cross-over voltage	V_{CRS}	1.3	—	2.0	V	Figure 2.111
	Rise time	t_{LR}	75	—	300	ns	
	Fall time	t_{LF}	75	—	300	ns	
	Rise/fall time ratio	t_{LR} / t_{LF}	80	—	125	%	t_{LR} / t_{LF}
Pull-up and pull-down characteristics	USB_DP and USB_DM pull-down resistance in host controller mode	R_{pd}	14.25	—	24.80	kΩ	—

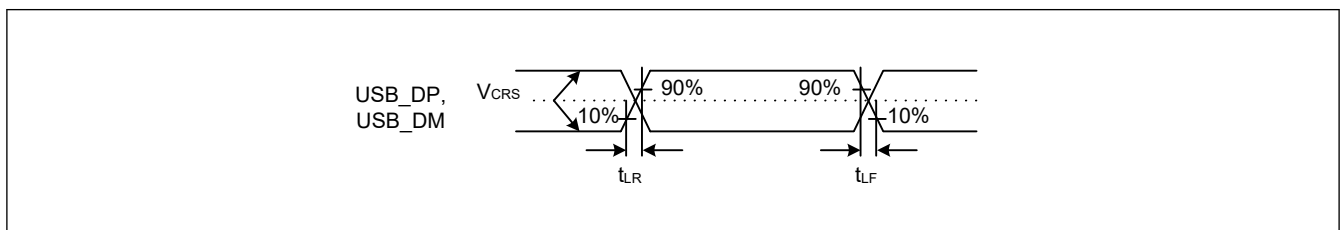

Figure 2.111 USB_DP and USB_DM output timing in low-speed mode

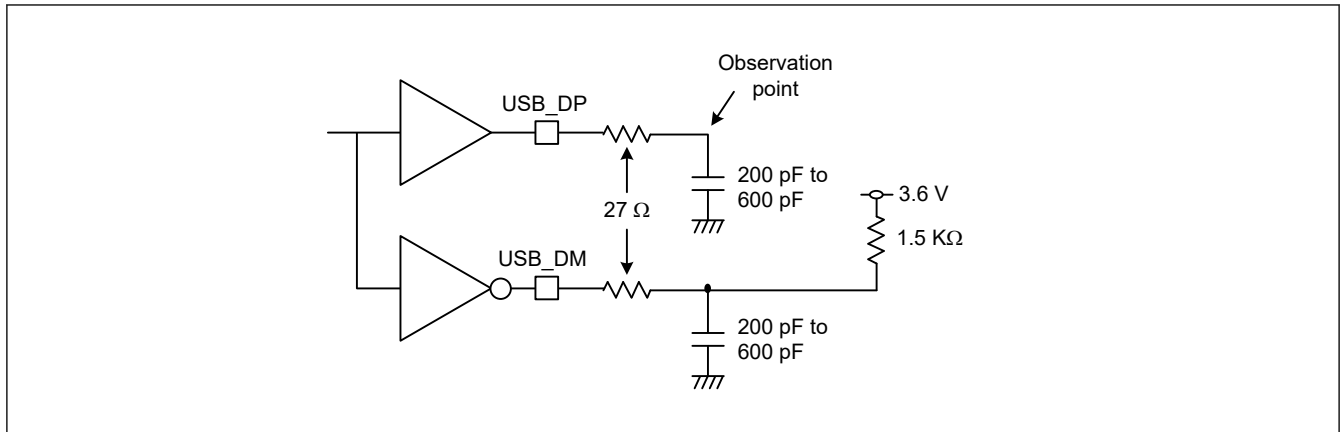

Figure 2.112 Test circuit in low-speed mode

Table 2.64 USBHS full-speed characteristics (USB_DP and USB_DM pin characteristics)

Conditions: USBHS_RREF = 2.2 kΩ ± 1%, USBMCLK = 12/20/24/48 MHz, USBCLK = 48MHz, USB60CLK = 60MHz

Parameter	Symbol	Min	Typ	Max	Unit	Test conditions	
Input characteristics	Input high voltage	V _{IH}	2.0	—	—	V	—
	Input low voltage	V _{IL}	—	—	0.8	V	—
	Differential input sensitivity	V _{DI}	0.2	—	—	V	USB_DP - USB_DM
	Differential common-mode range	V _{CM}	0.8	—	2.5	V	—
Output characteristics	Output high voltage	V _{OH}	2.8	—	3.6	V	I _{OH} = -200 μA
	Output low voltage	V _{OL}	0.0	—	0.3	V	I _{OL} = 2 mA
	Cross-over voltage	V _{CRS}	1.3	—	2.0	V	Figure 2.113
	Rise time	t _{LR}	4	—	20	ns	
	Fall time	t _{LF}	4	—	20	ns	
	Rise/fall time ratio	t _{LR} / t _{LF}	90	—	111.11	%	t _{FR} / t _{FF}
	Output resistance	Z _{DRV}	40.5	—	49.5	Ω	Rs Not used (PHYSET.REPSEL[1:0] = 01b and PHYSET.HSEB = 0)
Pull-up and pull-down characteristics	DM pull-up resistance in device controller mode	R _{pu}	0.900	—	1.575	kΩ	During idle state
			1.425	—	3.090	kΩ	During transmission and reception
	USB_DP and USB_DM pull-down resistance in host controller mode	R _{pd}	14.25	—	24.80	kΩ	—

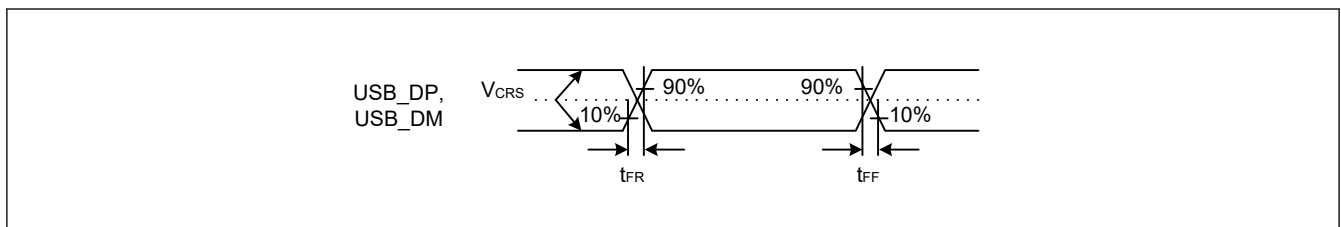

Figure 2.113 USB_DP and USB_DM output timing in full-speed mode

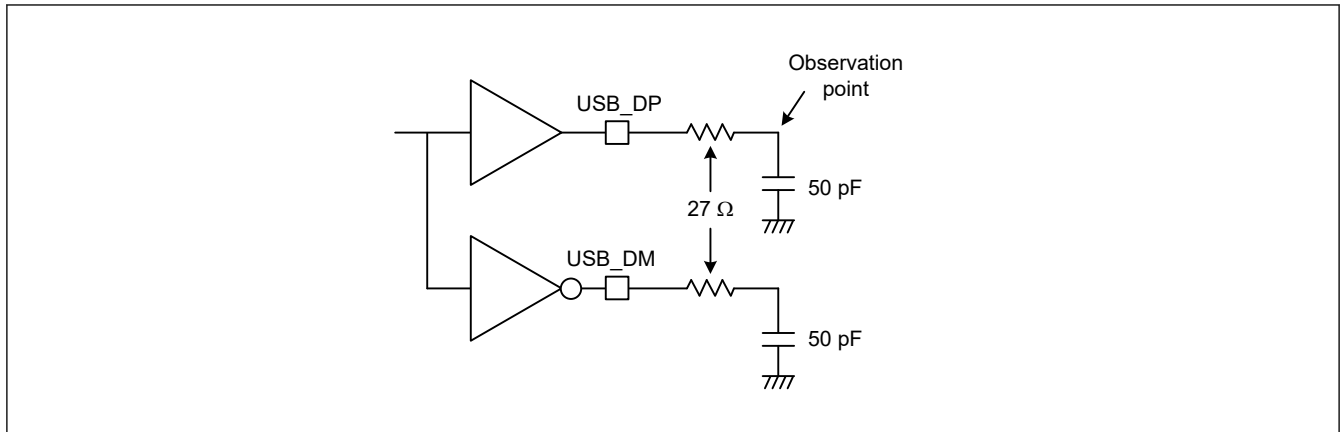

Figure 2.114 Test circuit in full-speed mode

Table 2.65 USB High Speed Characteristics (USB_DP and USB_DM Pin Characteristics)

Conditions: USBHS_RREF = 2.2 kΩ ± 1%, USBMCLK = 12/20/24/48 MHz

Parameter	Symbol	Min	Typ	Max	Unit	Test conditions	
Input characteristics	Squelch detect sensitivity	V _{HSSQ}	100	—	150	mV	Figure 2.115
	Disconnect detect sensitivity	V _{HSDSC}	525	—	625	mV	Figure 2.116
	Common mode voltage	V _{HSCM}	-50	—	500	mV	—
Output characteristics	Idle state	V _{HSOI}	-10	—	10	mV	—
	Output high level voltage	V _{HSOH}	360	—	440	mV	—
	Output low level voltage	V _{HSOL}	-10	—	10	mV	—
	Chirp J output voltage (difference)	V _{CHIRPJ}	700	—	1100	mV	—
	Chirp K output voltage (difference)	V _{CHIRPK}	-900	—	-500	mV	—
AC characteristics	Rise time	t _{HSR}	500	—	—	ps	—
	Fall time	t _{HSF}	500	—	—	ps	Figure 2.117
	Output resistance	Z _{HSDRV}	40.5	—	49.5	Ω	—

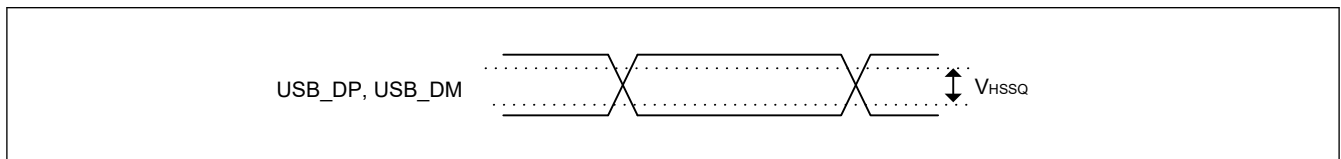

Figure 2.115 USB_DP and USB_DM squelch detect sensitivity (high-speed)

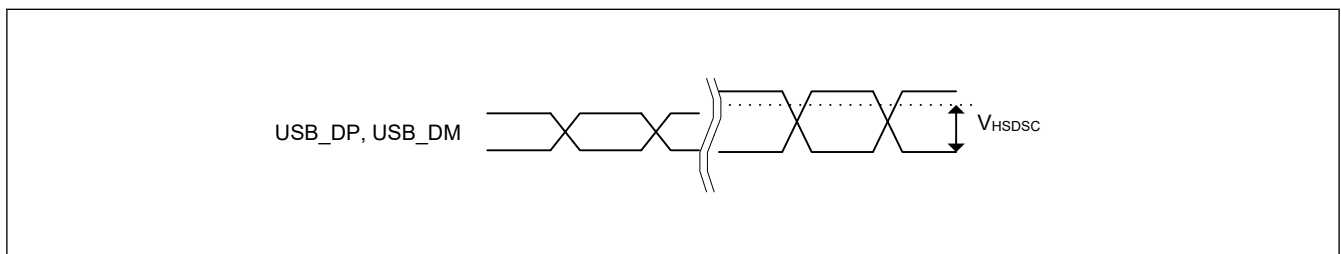

Figure 2.116 USB_DP and USB_DM disconnect detect sensitivity (high-speed)

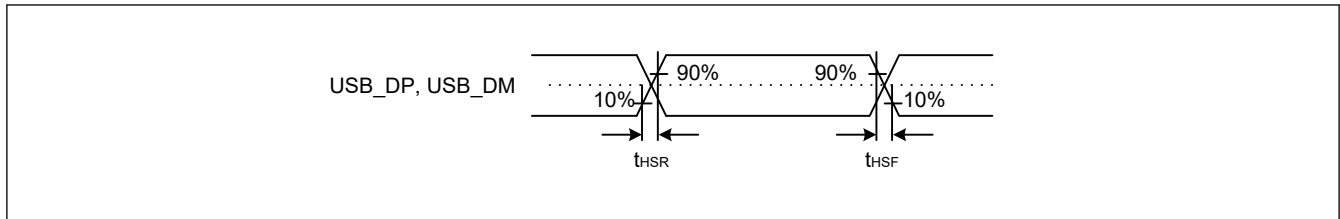

Figure 2.117 USB_DP and USB_DM output timing (high-speed)

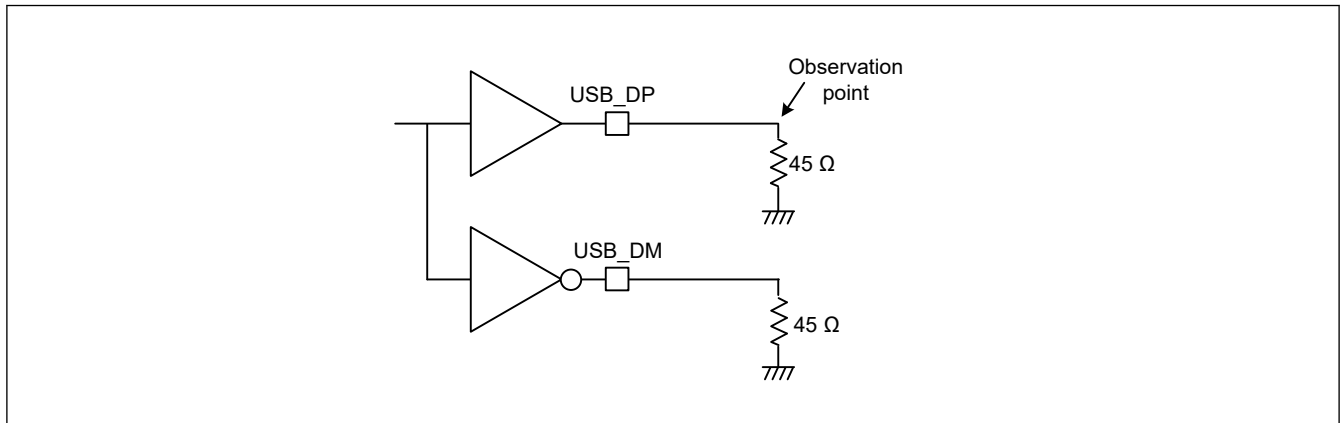

Figure 2.118 Test circuit (high-speed)

Table 2.66 USBHS high-speed characteristics (USB_DP and USB_DM pin characteristics)

Conditions: USBHS_RREF = 2.2 kΩ ± 1%, USBMCLK = 12/20/24/48 MHz

Parameter	Symbol	Min	Typ	Max	Unit	Test conditions	
Battery Charging Specification	D+ sink current	I _{DP_SINK}	25	—	175	μA	—
	D- sink current	I _{DM_SINK}	25	—	175	μA	—
	DCD source current	I _{DP_SRC}	7	—	13	μA	—
	Data detection voltage	V _{DAT_REF}	0.25	—	0.40	V	—
	D+ source voltage	V _{DP_SRC}	0.5	—	0.7	V	Output current = 250 μA
	D- source voltage	V _{DM_SRC}	0.5	—	0.7	V	Output current = 250 μA

2.5 MIPI D-PHY Characteristics

Table 2.67 Pin Characteristics

Parameter	Symbol	Min	Typ	Max	Unit	Note
Pin leakage current	I _{LEAK}	-100	—	100	μA	
Pin signal voltage range	V _{PIN}	-50	—	1350	mV	
Ground shift	V _{GNDSH}	-50	—	50	mV	

Table 2.68 HS-TX Characteristics (1 of 2)

Parameter	Symbol	Min	Typ	Max	Unit	Note
HS transmit static common-mode voltage	V _{CMTX}	150	200	250	mV	
V _{cmtx} mismatch when output is Differential-1 or Differential-0	ΔV _{CMTX(1,0)}	—	—	5.0	mV	
HS transmit differential voltage	V _{OD}	140	200	270	mV	
V _{OD} mismatch when output is Differential-1 or Differential-0	ΔV _{OD}	—	—	14.0	mV	
HS output high voltage	V _{OHS}	—	—	360	mV	

Table 2.68 HS-TX Characteristics (2 of 2)

Parameter	Symbol	Min	Typ	Max	Unit	Note	
Single ended output impedance	Z_{OS}	40.0	50.0	62.5	Ω		
Single ended output impedance mismatch	ΔZ_{OS}	—	—	20	%		
Data rate	—	40	—	720	Mbps	1 lane	
TX Data to Clock Skew	$T_{SKEW[TX]}$	-0.20	—	0.20	UIhs		
Common-level variations above 450MHz	$\Delta V_{CMTX(HF)}$	—	—	15.0	mVrms		
Common-level variations between 50-450MHz	$\Delta V_{CMTX(LF)}$	—	—	25.0	mVpeak		
20%-80% rise time and fall time	t_R	—	—	0.35	UIhs		
		100	—	—	ps		
	t_F	—	—	0.35	UIhs		
		100	—	—	ps		
Clock UI instantaneous	UI_{INST}	—	—	12.5	ns		
Clock UI variation	ΔUI	-10 %	—	10 %	UIhs		
Differential Return Loss	f_{HMIN}	S_{ddTX}	—	—	-15.00	dB	
	f_{HMIN}		—	—	-4.50		
	f_{MAX}		—	—	-2.50		
Common-mode Return Loss	$1/4f_{INT MIN}$	S_{ccTX}	—	—	0.00	dB	
	$f_{INT MIN}$		—	—	-6.00		
	f_{MAX}		—	—	-6.00		

Table 2.69 LP-TX Characteristics (1 of 2)

Parameter	Symbol	Min	Typ	Max	Unit	Note	
Thevenin output high level	V_{OH}	1.10	1.20	1.30	V		
Thevenin output low level	V_{OL}	-50	—	50	mV		
Output impedance of LP transmitter	high input	Z_{OLP}	110	—	—	Ω	
	low input	Z_{OLP}	110	—	—	Ω	
15%-85% rise time and fall time	T_{RLP}	—	—	25.0	ns		
	T_{FLP}	—	—	25.0	ns		
30%-85% rise time and fall time	T_{REOT}	—	—	35.0	ns		
Pulse width of the LP exclusive-OR clock	First LP exclusive-OR clock pulse after Stop state or last pulse before Stop state	$T_{LP-PULSE-TX}$	40	—	—	ns	
	All other pulses		20	—	—	ns	
Period of the LP exclusive-OR clock	$T_{LP-PER-TX}$	90	—	—	ns		

Table 2.69 LP-TX Characteristics (2 of 2)

Parameter	Symbol	Min	Typ	Max	Unit	Note
Slew rate at C _{LOAD} = 0pF	rise	—	—	500	mV/ns	
	fall					
Slew rate at C _{LOAD} = 5pF	rise					
	fall					
Slew rate at C _{LOAD} = 20pF	rise					
	fall					
Slew rate at C _{LOAD} = 70pF	rise					
	fall					
Slew rate at C _{LOAD} = 0 to 70pF (falling edge only)	30					
Slew rate at C _{LOAD} = 0 to 70pF (rising edge only)	30					
Slew rate at C _{LOAD} = 0 to 70pF (rising edge only)	30 – 0.075 × (V _{o,inst} – 700)	—	—	mV/ns	V _{o,inst} is the instantaneous output voltage in millivolts	
Load capacitance	C _{LOAD}	0	—	70	pF	

Table 2.70 LP-RX Characteristics

Parameter	Symbol	Min	Typ	Max	Unit	Note
Logic 1 input voltage	V _{IH}	740	—	—	mV	
Logic 0 input voltage, not in ULP state	V _{IL}	—	—	550	mV	
Logic 0 input voltage, ULP state	V _{IL-ULPS}	—	—	300	mV	
Input hysteresis	V _{HYST}	25.0	—	—	mV	
Input pulse rejection	e _{SPIKE}	—	—	300	Vps	
Minimum pulse width response	T _{MIN-RX}	20	—	—	ns	
Peak interference amplitude	V _{INT}	—	—	200	mV	
Interference frequency	f _{INT}	450	—	—	MHz	

Table 2.71 LP-CD Characteristics

Parameter	Symbol	Min	Typ	Max	Unit	Note
Logic 1 contention threshold	V _{IHCD}	450	—	—	mV	
Logic 0 contention threshold	V _{ILCD}	—	—	200	mV	
Input pulse rejection	e _{SPIKE}	—	—	300	Vps	
Peak interference amplitude	V _{INT}	—	—	200	mV	
Interference frequency	f _{INT}	450	—	—	MHz	

2.6 ADC12 Characteristics

Table 2.72 A/D conversion characteristics for unit 0 (DCDC mode) (1 of 3)

Conditions: PCLKC = 1 to 60 MHz

Parameter	Min	Typ	Max	Unit	Test conditions
Frequency	1	—	60	MHz	—
Analog input capacitance	—	—	30	pF	—
Quantization error	—	±0.5	—	LSB	—

Table 2.72 A/D conversion characteristics for unit 0 (DCDC mode) (2 of 3)

Conditions: PCLKC = 1 to 60 MHz

Parameter			Min	Typ	Max	Unit	Test conditions
Resolution			—	—	12	Bits	—
Channel-dedicated sample-and-hold circuits in use (AN000 to AN002)	Conversion time* ¹ (operation at PCLKC = 60 MHz)	Permissible signal source impedance Max. = 1 kΩ	1.06 (0.4 + 0.25)* ²	—	—	μs	<ul style="list-style-type: none"> Sampling of channel-dedicated sample-and-hold circuits in 24 states Sampling in 15 states
	Offset error		—	±1.5	±3.5	LSB	AN000 to AN002 = 0.25 V
	Full-scale error		—	±1.5	±3.5	LSB	AN000 to AN002 = VREFH0 - 0.25 V
	Absolute accuracy		—	±2.5	±10.5	LSB	LQFP package AVCC0 = 2.7 to 3.6V VREFH0 = 2.7V to AVCC0
			—	±2.5	±7.5		LQFP package AVCC0 = VREFH0 = 2.7 to 3.6V
			—	±2.5	±5.5		BGA package AVCC0 = 2.7 to 3.6V VREFH0 = 2.7V to AVCC0
	DNL differential nonlinearity error		—	±1.0	±2.0	LSB	—
	INL integral nonlinearity error		—	±1.5	±4.0	LSB	—
	Holding characteristics of sample-and-hold circuits		—	—	20	μs	—
Dynamic range		0.25	—	VREFH0 - 0.25	V	—	
High-precision channels, Channel-dedicated sample-and-hold circuits not in use (AN000 to AN002, AN004 to AN008)	Conversion time* ¹ (operation at PCLKC = 60 MHz)	Permissible signal source impedance Max. = 1 kΩ	0.48 (0.267)* ²	—	—	μs	Sampling in 16 states
		Max. = 400 Ω	0.40 (0.183)* ²	—	—	μs	Sampling in 11 states AVCC0 = VREFH0 = 3.0 to 3.6 V
	Offset error		—	±1.0	±2.5	LSB	—
	Full-scale error		—	±1.0	±3.5	LSB	—
	Absolute accuracy		—	±2.0	±7.5	LSB	LQFP package AVCC0 = 2.7 to 3.6V VREFH0 = 2.7V to AVCC0
			—	±2.0	±6.0		LQFP package AVCC0 = VREFH0 = 2.7 to 3.6V
			—	±2.0	±5.5		BGA package AVCC0 = 2.7 to 3.6V VREFH0 = 2.7V to AVCC0
	DNL differential nonlinearity error		—	±0.5	±2.0	LSB	—
INL integral nonlinearity error		—	±1.0	±2.5	LSB	—	

Table 2.72 A/D conversion characteristics for unit 0 (DCDC mode) (3 of 3)

Conditions: PCLKC = 1 to 60 MHz

Parameter			Min	Typ	Max	Unit	Test conditions
Normal-precision channels (AN016 to AN019)	Conversion time* ¹ (operation at PCLKC = 60 MHz)	Permissible signal source impedance Max. = 1 kΩ	0.88 (0.667) ^{*2}	—	—	μs	Sampling in 40 states
	Offset error		—	±1.0	±5.5	LSB	—
	Full-scale error		—	±1.0	±5.5	LSB	—
	Absolute accuracy		—	±2.0	±10.0	LSB	LQFP package AVCC0 = 2.7 to 3.6V VREFH0 = 2.7V to AVCC0
			—	±2.0	±7.5		LQFP package AVCC0 = VREFH0 = 2.7 to 3.6V
			—	±2.0	±7.5		BGA package AVCC0 = 2.7 to 3.6V VREFH0 = 2.7V to AVCC0
	DNL differential nonlinearity error		—	±0.5	±4.5	LSB	—
INL integral nonlinearity error		—	±1.0	±5.5	LSB	—	

Note: These specification values apply when only one A/D is operating and D/A and ACMPHS are not operating and there is no access to the external bus during A/D conversion.

If other A/D, D/A, or ACMPHS is operating or bus access occurs during A/D conversion, values might not fall within the indicated ranges.

The use of ports 0 as digital outputs is not allowed when the 12-Bit A/D converter is used.

The characteristics apply when AVCC0, AVSS0, VREFH0, VREFH, VREFL0, VREFL, and 12-bit A/D converter input voltage is stable.

Note 1. The conversion time includes the sampling and comparison times. The number of sampling states is indicated for the test conditions.

Note 2. Values in parentheses indicate the sampling time.

Table 2.73 A/D conversion characteristics for unit 1 (DCDC mode) (1 of 2)

Conditions: PCLKC = 1 to 60 MHz

Parameter			Min	Typ	Max	Unit	Test conditions
Frequency			1	—	60	MHz	—
Analog input capacitance			—	—	30	pF	—
Quantization error			—	±0.5	—	LSB	—
Resolution			—	—	12	Bits	—
High-precision channels (AN100 to AN102, AN104 to AN106)	Conversion time* ¹ (operation at PCLKC = 60 MHz)	Permissible signal source impedance Max. = 1 kΩ	0.48 (0.267) ^{*2}	—	—	μs	Sampling in 16 states
		Max. = 400 Ω	0.40 (0.183) ^{*2}	—	—	μs	Sampling in 11 states AVCC0 = VREFH = 3.0 to 3.6 V
	Offset error		—	±1.0	±2.5	LSB	—
	Full-scale error		—	±1.0	±3.5	LSB	—
	Absolute accuracy		—	±2.0	±7.5	LSB	LQFP package AVCC0 = 2.7 to 3.6V VREFH = 2.7V to AVCC0
			—	±2.0	±6.0		LQFP package AVCC0 = VREFH = 2.7 to 3.6V
			—	±2.0	±5.5		BGA package AVCC0 = 2.7 to 3.6V VREFH = 2.7V to AVCC0
	DNL differential nonlinearity error		—	±0.5	±2.0	LSB	—
INL integral nonlinearity error		—	±1.0	±2.5	LSB	—	

Table 2.73 A/D conversion characteristics for unit 1 (DCDC mode) (2 of 2)

Conditions: PCLKC = 1 to 60 MHz

Parameter			Min	Typ	Max	Unit	Test conditions
Normal-precision channels (AN116 to AN122)	Conversion time* ¹ (operation at PCLKC = 60 MHz)	Permissible signal source impedance Max. = 1 kΩ	0.88 (0.667)* ²	—	—	μs	Sampling in 40 states
	Offset error		—	±1.0	±5.5	LSB	—
	Full-scale error		—	±1.0	±5.5	LSB	—
	Absolute accuracy		—	±2.0	±10.0	LSB	LQFP package AVCC0 = 2.7 to 3.6V VREFH = 2.7V to AVCC0
			—	±2.0	±7.5		LQFP package AVCC0 = VREFH = 2.7 to 3.6V
			—	±2.0	±7.5		BGA package AVCC0 = 2.7 to 3.6V VREFH = 2.7V to AVCC0
	DNL differential nonlinearity error		—	±0.5	±4.5	LSB	—
INL integral nonlinearity error		—	±1.0	±5.5	LSB	—	

Note: These specification values apply when only one A/D is operating and D/A and ACMPHS are not operating and there is no access to the external bus during A/D conversion.

If other A/D, D/A, or ACMPHS is operating or bus access occurs during A/D conversion, values might not fall within the indicated ranges.

The use of ports 0 as digital outputs is not allowed when the 12-Bit A/D converter is used.

The characteristics apply when AVCC0, AVSS0, VREFH0, VREFH, VREFL0, VREFL, and 12-bit A/D converter input voltage are stable.

Note 1. The conversion time includes the sampling and comparison times. The number of sampling states is indicated for the test conditions.

Note 2. Values in parentheses indicate the sampling time.

Table 2.74 A/D conversion characteristics for unit 0 (External VDD mode) (1 of 2)

Conditions: PCLKC = 1 to 60 MHz

AVCC0 = 2.7 to 3.6 V, VREFH0 = 2.7 to 3.6 V

Parameter			Min	Typ	Max	Unit	Test conditions
Frequency			1	—	60	MHz	—
Analog input capacitance			—	—	30	pF	—
Quantization error			—	±0.5	—	LSB	—
Resolution			—	—	12	Bits	—
Channel-dedicated sample-and-hold circuits in use (AN000 to AN002)	Conversion time* ¹ (operation at PCLKC = 60 MHz)	Permissible signal source impedance Max. = 1 kΩ	1.06 (0.4 + 0.25)* ²	—	—	μs	<ul style="list-style-type: none"> Sampling of channel-dedicated sample-and-hold circuits in 24 states Sampling in 15 states
	Offset error		—	±1.5	±3.5	LSB	AN000 to AN002 = 0.25 V
	Full-scale error		—	±1.5	±3.5	LSB	AN000 to AN002 = VREFH0 - 0.25 V
	Absolute accuracy		—	±2.5	±5.5	LSB	—
	DNL differential nonlinearity error		—	±1.0	±2.0	LSB	—
	INL integral nonlinearity error		—	±1.5	±3.0	LSB	—
	Holding characteristics of sample-and hold circuits		—	—	20	μs	—
Dynamic range		0.25	—	VREF H 0 - 0.25	V	—	

Table 2.74 A/D conversion characteristics for unit 0 (External VDD mode) (2 of 2)

Conditions: PCLKC = 1 to 60 MHz
AVCC0 = 2.7 to 3.6 V, VREFH0 = 2.7 to 3.6 V

Parameter			Min	Typ	Max	Unit	Test conditions
High-precision channels, Channel-dedicated sample-and-hold circuits not in use (AN000 to AN002, AN004 to AN008)	Conversion time*1 (operation at PCLKC = 60 MHz)	Permissible signal source impedance Max. = 1 kΩ	0.48 (0.267)*2	—	—	μs	Sampling in 16 states
		Max. = 400 Ω	0.40 (0.183)*2	—	—	μs	Sampling in 11 states AVCC0 = 3.0 to 3.6 V 3.0 V ≤ VREFH0 ≤ AVCC0
	Offset error		—	±1.0	±2.5	LSB	—
	Full-scale error		—	±1.0	±3.5	LSB	—
	Absolute accuracy		—	±2.0	±4.5	LSB	—
	DNL differential nonlinearity error		—	±0.5	±1.5	LSB	—
INL integral nonlinearity error		—	±1.0	±2.5	LSB	—	
Normal-precision channels (AN016 to AN019)	Conversion time*1 (operation at PCLKC = 60 MHz)	Permissible signal source impedance Max. = 1 kΩ	0.88 (0.667)*2	—	—	μs	Sampling in 40 states
		Max. = 400 Ω	0.40 (0.183)*2	—	—	μs	Sampling in 11 states AVCC0 = 3.0 to 3.6 V 3.0 V ≤ VREFH0 ≤ AVCC0
	Offset error		—	±1.0	±5.5	LSB	—
	Full-scale error		—	±1.0	±5.5	LSB	—
	Absolute accuracy		—	±2.0	±7.5	LSB	—
	DNL differential nonlinearity error		—	±0.5	±4.5	LSB	—
INL integral nonlinearity error		—	±1.0	±5.5	LSB	—	

Note: These specification values apply when only one A/D is operating and D/A and ACMPHS are not operating and there is no access to the external bus during A/D conversion.
If other A/D, D/A, or ACMPHS is operating or bus access occurs during A/D conversion, values might not fall within the indicated ranges.
The use of ports 0 as digital outputs is not allowed when the 12-Bit A/D converter is used.
The characteristics apply when AVCC0, AVSS0, VREFH0, VREFH, VREFL0, VREFL, and 12-bit A/D converter input voltage is stable.

Note 1. The conversion time includes the sampling and comparison times. The number of sampling states is indicated for the test conditions.

Note 2. Values in parentheses indicate the sampling time.

Table 2.75 A/D conversion characteristics for unit 1 (External VDD mode) (1 of 2)

Conditions: PCLKC = 1 to 60 MHz
AVCC0 = 2.7 to 3.6 V, VREFH = 2.7 to 3.6 V

Parameter	Min	Typ	Max	Unit	Test conditions
Frequency	1	—	60	MHz	—
Analog input capacitance	—	—	30	pF	—
Quantization error	—	±0.5	—	LSB	—
Resolution	—	—	12	Bits	—

Table 2.75 A/D conversion characteristics for unit 1 (External VDD mode) (2 of 2)

Conditions: PCLKC = 1 to 60 MHz
 AVCC0 = 2.7 to 3.6 V, VREFH = 2.7 to 3.6 V

Parameter			Min	Typ	Max	Unit	Test conditions
High-precision channels (AN100 to AN102, AN104 to AN106)	Conversion time*1 (operation at PCLKC = 60 MHz)	Permissible signal source impedance Max. = 1 kΩ	0.48 (0.267)*2	—	—	μs	Sampling in 16 states
		Max. = 400 Ω	0.40 (0.183)*2	—	—	μs	Sampling in 11 states AVCC0 = 3.0 to 3.6 V 3.0 V ≤ VREFH ≤ AVCC0
	Offset error		—	±1.0	±2.5	LSB	—
	Full-scale error		—	±1.0	±3.5	LSB	—
	Absolute accuracy		—	±2.0	±4.5	LSB	—
	DNL differential nonlinearity error		—	±0.5	±1.5	LSB	—
INL integral nonlinearity error		—	±1.0	±2.5	LSB	—	
Normal-precision channels (AN116 to AN122)	Conversion time*1 (operation at PCLKC = 60 MHz)	Permissible signal source impedance Max. = 1 kΩ	0.88 (0.667)*2	—	—	μs	Sampling in 40 states
		Offset error		—	±1.0	±5.5	LSB
	Full-scale error		—	±1.0	±5.5	LSB	—
	Absolute accuracy		—	±2.0	±7.5	LSB	—
	DNL differential nonlinearity error		—	±0.5	±4.5	LSB	—
	INL integral nonlinearity error		—	±1.0	±5.5	LSB	—

Note: These specification values apply when only one A/D is operating and D/A and ACMPHS are not operating and there is no access to the external bus during A/D conversion.

If other A/D, D/A, or ACMPHS is operating or bus access occurs during A/D conversion, values might not fall within the indicated ranges.

The use of ports 0 as digital outputs is not allowed when the 12-Bit A/D converter is used.

The characteristics apply when AVCC0, AVSS0, VREFH0, VREFH, VREFL0, VREFL, and 12-bit A/D converter input voltage are stable.

Note 1. The conversion time includes the sampling and comparison times. The number of sampling states is indicated for the test conditions.

Note 2. Values in parentheses indicate the sampling time.

Table 2.76 A/D internal reference voltage characteristics

Parameter	Min	Typ	Max	Unit	Test conditions
A/D internal reference voltage	1.13	1.18	1.28	V	—
Sampling time	4.15	—	—	μs	—

For the characteristics of VBATT 1/3 voltage monitor, please see [section 2.11. VBATT Characteristics](#).

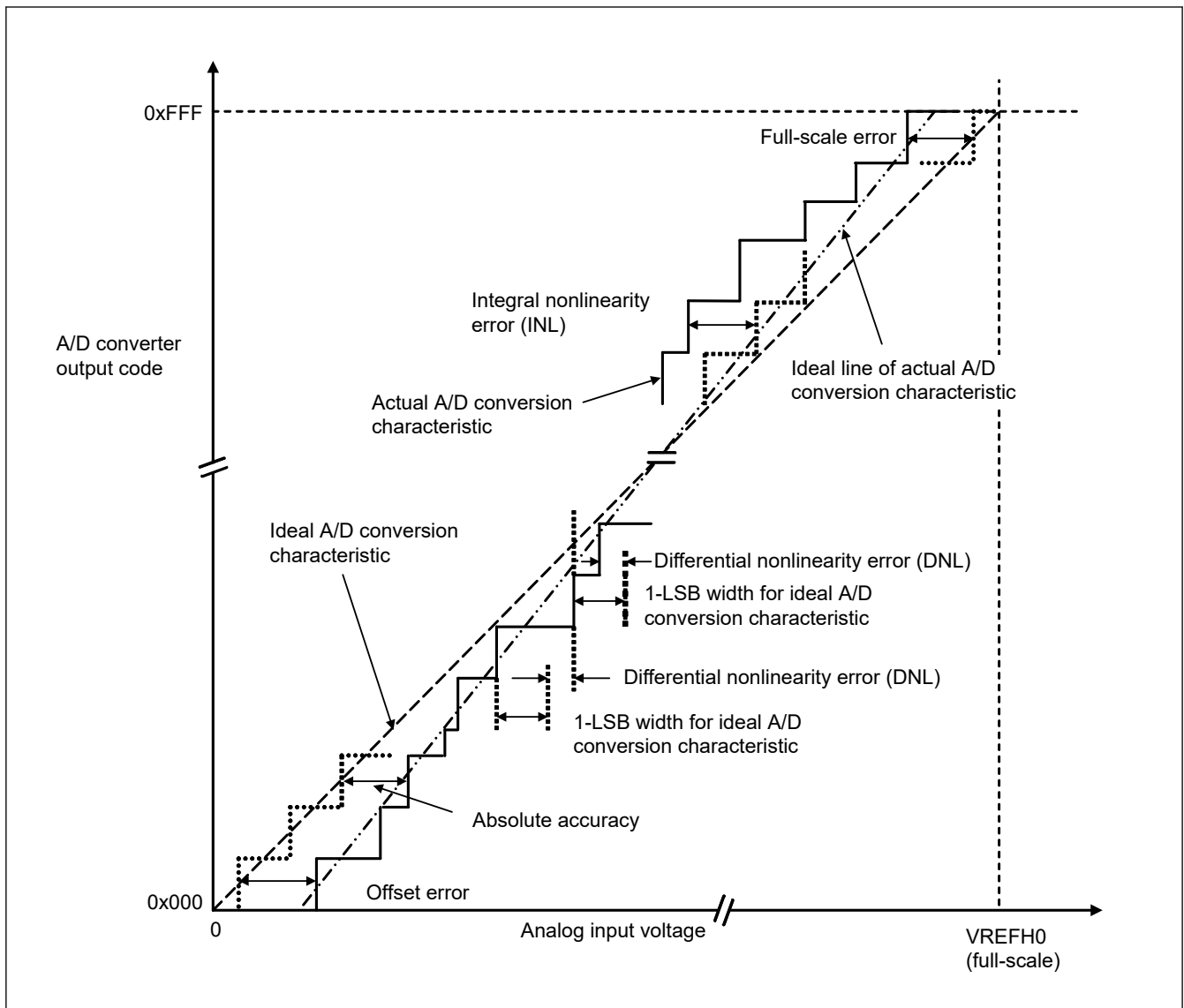

Figure 2.119 Illustration of ADC12 characteristic terms

Absolute accuracy

Absolute accuracy is the difference between output code based on the theoretical A/D conversion characteristics, and the actual A/D conversion result. When measuring absolute accuracy, the voltage at the midpoint of the width of the analog input voltage (1-LSB width), which can meet the expectation of outputting an equal code based on the theoretical A/D conversion characteristics, is used as an analog input voltage. For example, if 12-bit resolution is used and the reference voltage $V_{REFH0} = 3.072$ V, then the 1-LSB width becomes 0.75 mV, and 0 mV, 0.75 mV, and 1.5 mV are used as the analog input voltages. If the analog input voltage is 6 mV, an absolute accuracy of ± 5 LSB means that the actual A/D conversion result is in the range of 0x003 to 0x00D, though an output code of 0x008 can be expected from the theoretical A/D conversion characteristics.

Integral nonlinearity error (INL)

Integral nonlinearity error is the maximum deviation between the ideal line when the measured offset and full-scale errors are zeroed, and the actual output code.

Differential nonlinearity error (DNL)

Differential nonlinearity error is the difference between the 1-LSB width based on the ideal A/D conversion characteristics and the width of the actual output code.

Offset error

Offset error is the difference between the transition point of the ideal first output code and the actual first output code.

Full-scale error

Full-scale error is the difference between the transition point of the ideal last output code and the actual last output code.

2.7 DAC12 Characteristics**Table 2.77 D/A conversion characteristics**

Parameter	Min	Typ	Max	Unit	Test conditions	
Resolution	—	—	12	Bits	—	
Without output amplifier (for pin output, AVCC0 ≥ 1.65V)						
Absolute accuracy	VREFH ≥ 2.7V	—	—	±24	LSB	Resistive load 2 MΩ
	VREFH < 2.7V	—	—	±36		
INL	VREFH ≥ 2.7V	—	±2.0	±8.0	LSB	Resistive load 2 MΩ
	VREFH < 2.7V	—	±2.0	±8.0		
DNL	VREFH ≥ 2.7V	—	±1.0	±2.0	LSB	—
	VREFH < 2.7V	—	±1.0	±3.0		
Output impedance	—	8.5	—	kΩ	—	
Conversion time	VREFH ≥ 2.7V	—	—	3.0	μs	Resistive load 2 MΩ, Capacitive load 20 pF
	VREFH < 2.7V	—	—	6.0		
Output voltage range	0	—	VREFH	V	—	
Without output amplifier (for internal output, AVCC0 ≥ 1.65V)						
Absolute accuracy	VREFH ≥ 2.7V	—	—	±4.0	LSB	—
	VREFH < 2.7V	—	—	±6.0		
Conversion time	VREFH ≥ 2.7V	—	—	3.0	μs	—
	VREFH < 2.7V	—	—	6.0		
Output voltage range	0	—	VREFH	V	—	
With output amplifier (AVCC0 ≥ 2.70V)						
INL	—	±2.0	±4.0	LSB	—	
DNL	—	±1.0	±2.0	LSB	—	
Conversion time	—	—	3.5	μs	—	
Resistive load	5	—	—	kΩ	—	
Capacitive load	—	—	50	pF	—	
Output voltage range	VREFH ≥ 2.7V	0.20	—	VREFH – 0.20	V	—
	VREFH < 2.7V	0.22	—	VREFH – 0.22		—

2.8 TSN Characteristics

Table 2.78 TSN characteristics

Parameter	Symbol	Min	Typ	Max	Unit	Test conditions
Relative accuracy	—	—	± 1.0	—	°C	—
Temperature slope	—	—	4.0	—	mV/°C	—
Output voltage (at 25 °C)	—	—	1.24	—	V	—
Temperature sensor start time	t _{START}	—	—	30	μs	—
Sampling time	—	4.15	—	—	μs	—

2.9 OSC Stop Detect Characteristics

Table 2.79 Oscillation stop detection circuit characteristics

Parameter	Symbol	Min	Typ	Max	Unit	Test conditions
Detection time	t _{dr}	—	—	1	ms	Figure 2.120

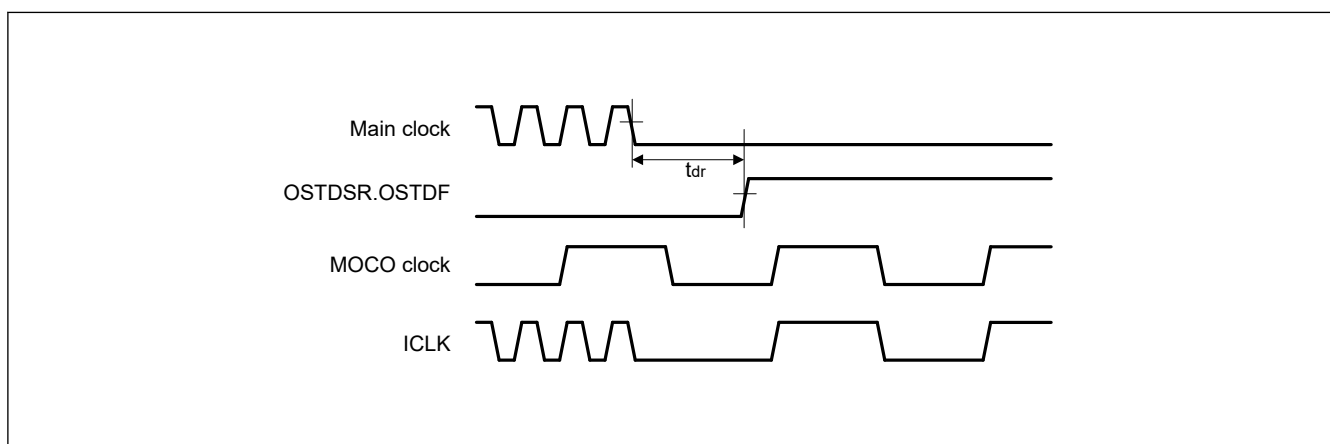

Figure 2.120 Oscillation stop detection timing

2.10 POR and PVD Characteristics

Table 2.80 Power-on reset circuit and voltage detection circuit characteristics (1 of 2)

Parameter		Symbol	Min	Typ	Max	Unit	Test conditions	
Voltage detection level	Power-on reset (POR)	Tj = 25°C	V _{POR1}	1.55	1.60	1.68	V	Figure 2.121
				Tj = 125°C	1.55	1.60		
		Tj = 25°C	V _{POR2}	1.65	1.70	1.79		
				Tj = 125°C	1.65	1.70		
	Voltage detection circuit (PVD0)	V _{det0_0}	2.76	2.85	2.99	Figure 2.122		
		V _{det0_1}	2.50	2.58	2.71			
		V _{det0_2}	2.08	2.15	2.27			
		V _{det0_3}	1.94	2.00	2.12			
		V _{det0_4}	1.84	1.90	2.01			
		V _{det0_5}	1.74	1.80	1.91			
		V _{det0_6}	1.65	1.70	1.81			
		V _{det0_7}	1.55	1.60	1.70			
	Voltage detection circuit (PVDn) (n = 1, 2)	V _{detn_3_rise}	3.78	3.92	4.10	Figure 2.123		
		V _{detn_3_fall}	3.72	3.86	4.04			
		V _{detn_4_rise}	3.09	3.20	3.35			
		V _{detn_4_fall}	3.03	3.14	3.29			
		V _{detn_5_rise}	3.05	3.16	3.31			
		V _{detn_5_fall}	2.99	3.10	3.25			
		V _{detn_6_rise}	3.03	3.14	3.29			
		V _{detn_6_fall}	2.97	3.08	3.23			
V _{detn_7_rise}		2.81	2.91	3.05				
V _{detn_7_fall}		2.75	2.85	2.99				
V _{detn_8_rise}		2.79	2.89	3.03				
V _{detn_8_fall}		2.73	2.83	2.97				
V _{detn_9_rise}		2.76	2.86	3.00				
V _{detn_9_fall}		2.70	2.80	2.94				
V _{detn_10_rise}		2.58	2.67	2.80				
V _{detn_10_fall}		2.53	2.62	2.75				
Voltage detection level	Voltage detection circuit (PVDn) (n = 1, 2)	V _{detn_12_rise}	1.88	1.94	2.05	V	Figure 2.123	
		V _{detn_12_fall}	1.84	1.90	2.01			
		V _{detn_13_rise}	1.84	1.90	2.01			
		V _{detn_13_fall}	1.80	1.86	1.97			
		V _{detn_14_rise}	1.72	1.78	1.89			
		V _{detn_14_fall}	1.68	1.74	1.85			
		V _{detn_15_rise}	1.69	1.75	1.85			
		V _{detn_15_fall}	1.65	1.71	1.81			

Table 2.80 Power-on reset circuit and voltage detection circuit characteristics (2 of 2)

Parameter	Symbol	Min	Typ	Max	Unit	Test conditions	
Internal reset time* ¹	Power-on reset time	t_{POR1}	—	—	8.2	ms Figure 2.121	
		t_{POR2}	—	—	4.5		
	PVD0 reset time	t_{PVD0}	—	—	*1		
	PVD1 reset time	t_{PVD1}	—	—	*1		
	PVD2 reset time	t_{PVD2}	—	—	*1		
Minimum VCC down time (POR)* ²	100mV < VD	t_{VOFFP}	500	—	—	μs Figure 2.121	
	50mV < VD ≤ 100mV		900	—	—		
	VD ≤ 50mV		2000	—	—		
Minimum VCC down time (PVD)* ²	PVD0 (OFS1(_SEC).PVDLPSEL = 0 in Deep Software Standby mode 1, 2)	t_{VOFF}	400	—	—	μs Figure 2.122	
	PVD0 (Other than above), PVD1, PVD2		200	—	—		
Response delay time (POR)	100mV < VD	t_{detp}	—	—	500	μs Figure 2.121	
	50mV < VD ≤ 100mV		—	—	900		
	VD ≤ 50mV		—	—	2000		
Response delay time (PVD)	PVD0 (OFS1(_SEC).PVDLPSEL = 0 in Deep Software Standby mode 1, 2)	50mV < VD	t_{det}	—	—	μs Figure 2.122, Figure 2.123	
		50mV ≥ VD		—	—		200
	PVD0 (Other than above), PVD1, PVD2	100mV < VD		—	—		10
		100mV ≥ VD		—	—		200
PVD operation stabilization time (after PVD is enabled)	$T_d (E-A)$	—	—	20	μs Figure 2.123		

Note 1. The maximum value of t_{PVD0} is equal to t_{DSBY} because the internal reset time is maximized when returning from Deep Software Standby mode.
 The maximum value of t_{PVD1} , t_{PVD2} are equal to t_{STBY} because the internal reset time is maximized when returning from Deep Software Standby mode.

Note 2. The minimum VCC down time indicates the time when VCC is below the minimum value of voltage detection levels V_{POR1} , V_{det1} , and V_{det2} for the POR / PVD.

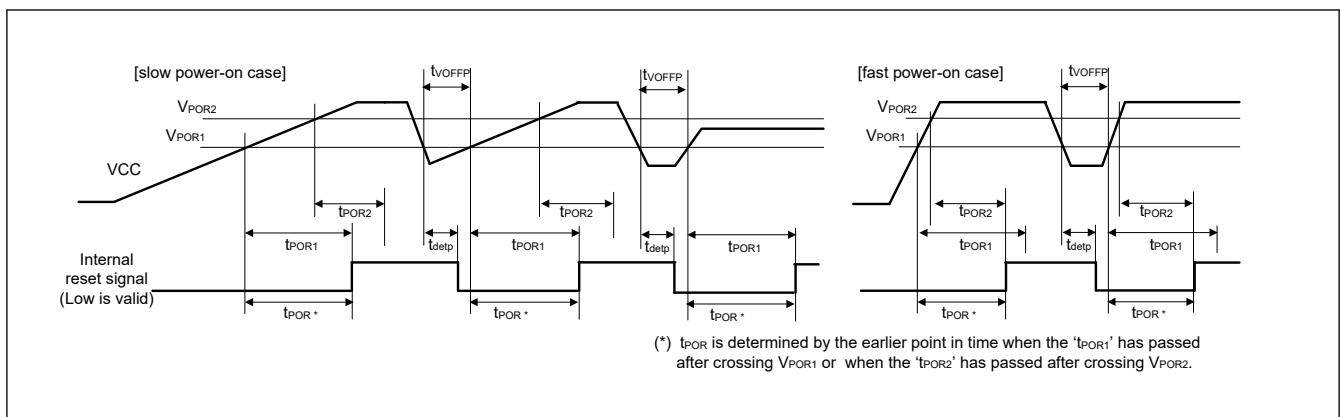

Figure 2.121 Power-on reset timing

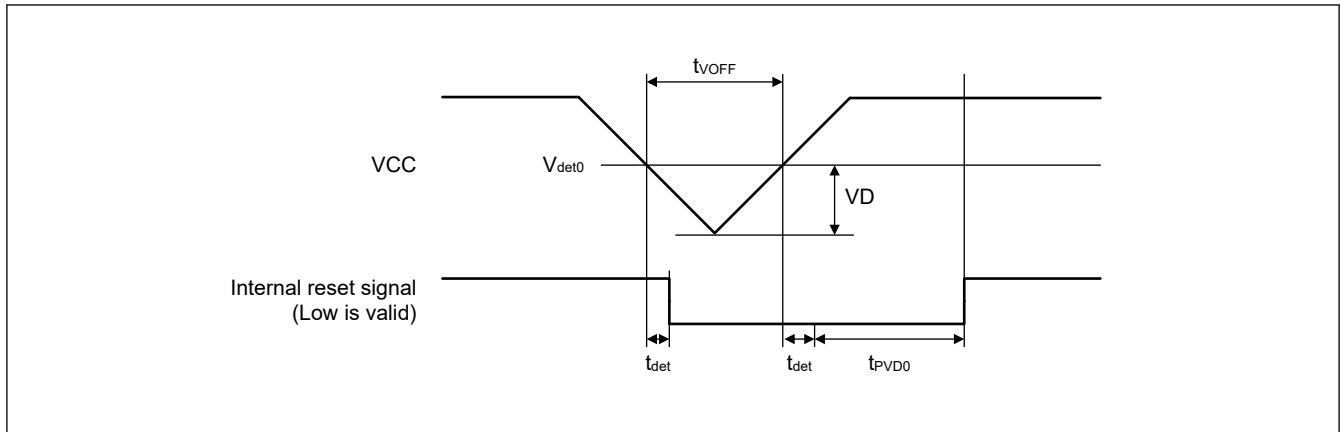

Figure 2.122 Voltage detection circuit timing (V_{det0})

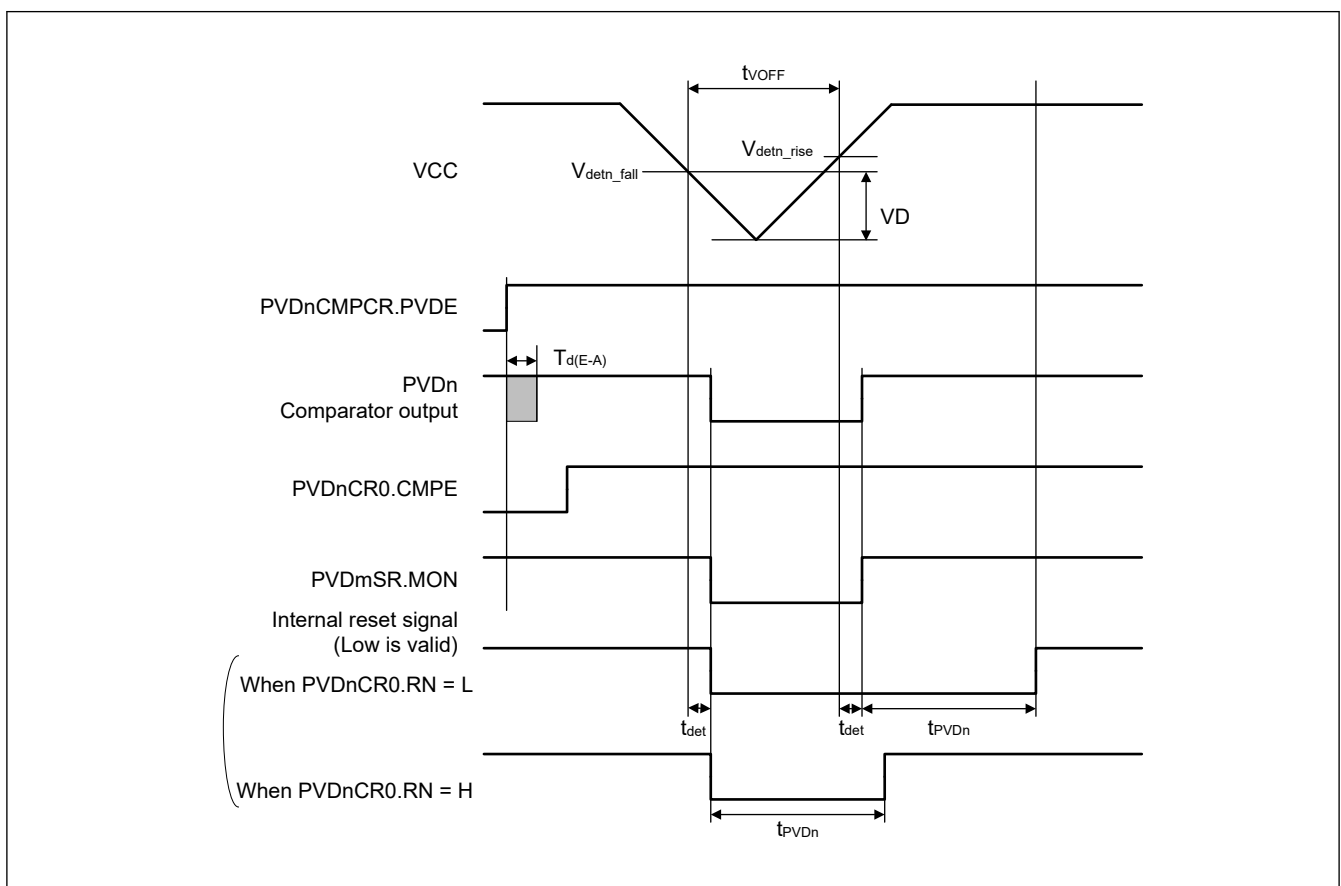

Figure 2.123 Voltage detection circuit timing (V_{detn}) (n = 1, 2)

2.11 VBATT Characteristics

Table 2.81 Battery backup function characteristics

Conditions: VCC = VCC_DCDC = VCC_USB = 1.68 to 3.6 V, VBATT = 1.62 to 3.6 V

Parameter	Symbol	Min	Typ	Max	Unit	Test conditions
Voltage level for switching to battery backup OFS1(_SEC).PVDAS and PVDLPSEL are 0 in Deep Software Standby mode 1, 2 (VDETVATT_n follows VDSEL[2:0] setting for PVD0)	V _{DETBATT_0}	2.760	2.850	2.990	V	Figure 2.124
	V _{DETBATT_1}	2.500	2.580	2.710		
	V _{DETBATT_2}	2.080	2.150	2.270		
	V _{DETBATT_3}	1.940	2.000	2.120		
	V _{DETBATT_4}	1.840	1.900	2.010		
	V _{DETBATT_5}	1.740	1.800	1.910		
	V _{DETBATT_6}	1.650	1.700	1.810		
Voltage level for switching to battery backup (Other than above)	V _{DETBATT_0}	2.710	2.800	2.940	V	
	V _{DETBATT_1}	2.450	2.530	2.660		
	V _{DETBATT_2}	2.030	2.100	2.220		
	V _{DETBATT_3}	1.855	1.950	2.065		
	V _{DETBATT_4}	1.790	1.850	1.960		
	V _{DETBATT_5}	1.690	1.750	1.860		
VCC drop detection stabilization wait time*2	t _{DETWT}	—	—	20	μs	
Lower-limit VBATT voltage for power supply switching caused by VCC voltage drop	V _{BATTSW}	2.0	—	—	V	Figure 2.124
VCC-off period for starting power supply switching*1 (OFS1(_SEC).PVDAS and PVDLPSEL are 0 in Deep Software Standby mode 1, 2)	t _{VOFFBATT}	400	—	—	μs	
VCC-off period for starting power supply switching*1 (Other than above)		200	—	—		
Backup domain power-down detection level	V _{PDR} (BATR)	1.45	1.50	1.60	V	Figure 2.125
Time delay in assertion of the reset signal for the backup domain*3	t _p (PDRL)	—	—	2000	μs	
Time delay in negation of the reset signal for the backup domain	t _p (PDRH)	—	—	3000		
VBATT monitor operation stabilization time (after VBATTMNSLR.VBTMNSLR is changed to 1)	t _{MONWT}	—	—	4.2	μs	—
VBATT voltage monitor level	V _{MONBATT}	—	VBATT / 3	—	V	—
VBATT current increase (when VBATTMNSLR.VBTMNSLR is 1 compared to the case that VBATTMNSLR.VBTMNSLR is 0)	I _{VBATTSELB}	—	1.50	2.35	μA	—
VCC current increase (when VBATTMNSLR.VBTMNSLR is 1 compared to the case that VBATTMNSLR.VBTMNSLR is 0)	I _{VBATTSELC}	—	330	577	μA	—

Note 1. The VCC-off period for starting power supply switching indicates the period in which VCC is below the minimum value of the voltage level for switching to battery backup (V_{DETBATT}).

In addition, this period indicates the time t_{VOFFP} when VCC is below the minimum value of voltage detection levels V_{POR1}.

Note 2. Stable time when VBTBPCR2.VDETLVL is changed or VBTBPCR2.VDETLVL is changed from 0 to 1.

Note 3. When the VBATT_R recovers within this period, the backup domain reset signal may not be generated.

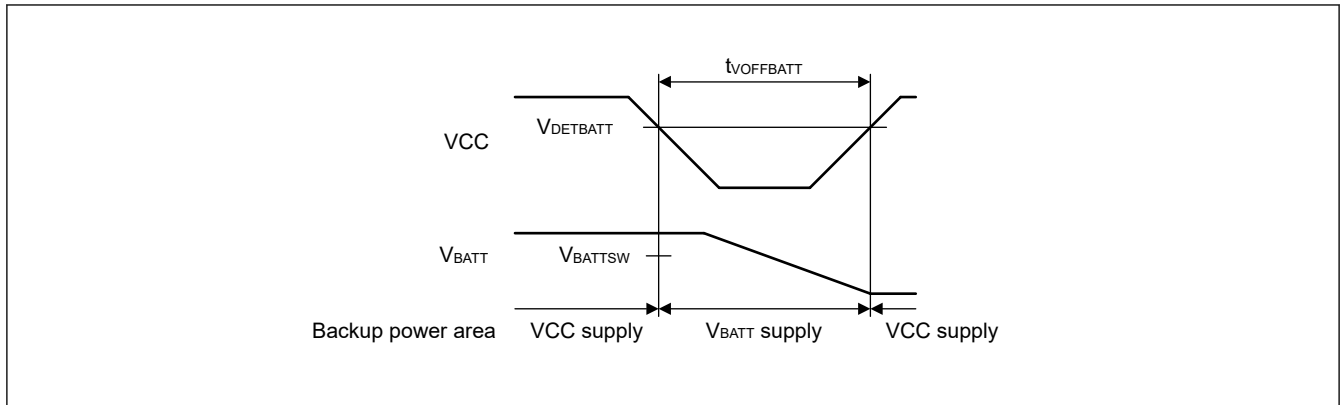

Figure 2.124 Battery backup function characteristics

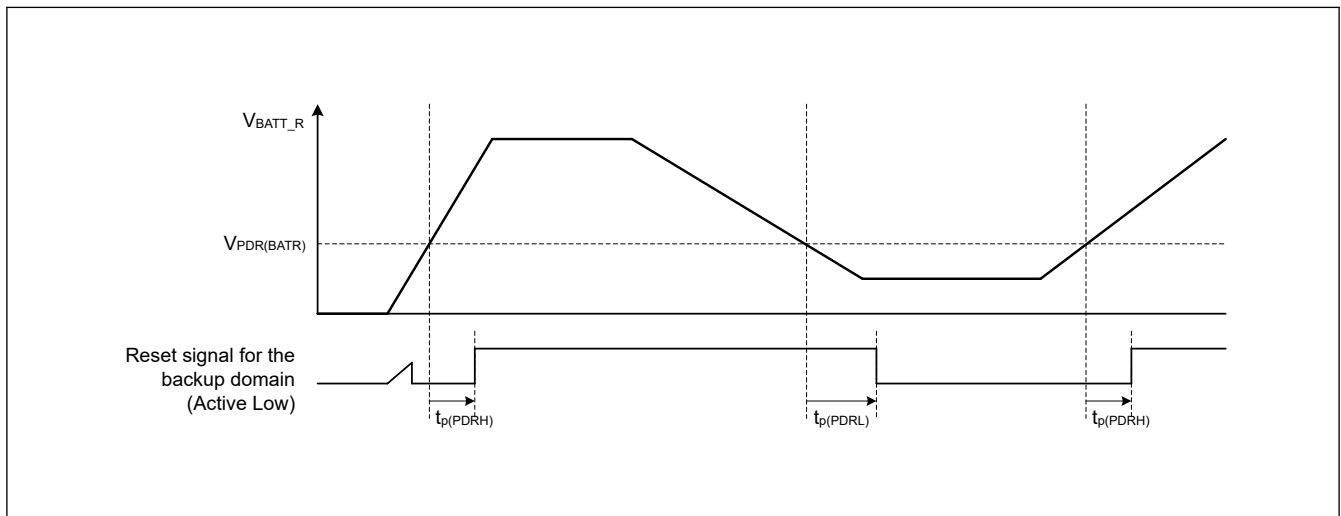

Figure 2.125 Backup Domain Reset Characteristics

2.12 ACMPHS Characteristics

Table 2.82 ACMPHS

Parameter	Symbol	Min	Typ	Max	Unit	Test conditions	
Reference voltage range	VREF	0	—	AVCC0	V	—	
Input voltage range	ACMPHS0	VI	0	—	AVCC0	V	—
	ACMPHS1		0	—	AVCC0		—
			IVCMP1 to IVCMP3	0	—		AVCC0
	IVCMP0		0	—	VCC		VCC < AVCC0
Output delay*1	Td	—	50	100	ns	VI = VREF ± 100mV	
Internal reference voltage	Vref	1.13	1.18	1.28	V	—	

Note 1. This value is the internal propagation delay.

2.13 Flash Memory Characteristics

2.13.1 Code Flash Memory Characteristics

Table 2.83 Code flash memory characteristics

Conditions: Program or erase: FCLK = 4 to 60 MHz

Read: FCLK ≤ 60 MHz

Parameter	Symbol	FCLK = 4 MHz			20 MHz ≤ FCLK ≤ 60 MHz			Unit	Test conditions	
		Min	Typ ^{*6}	Max	Min	Typ ^{*6}	Max			
Programming time N _{PEC} ≤ 100 times	128-byte	t _{P128}	—	0.75	13.2	—	0.34	6.0	ms	
	8-KB	t _{P8K}	—	49	176	—	22	80	ms	
	32-KB	t _{P32K}	—	194	704	—	88	320	ms	
Programming time N _{PEC} > 100 times	128-byte	t _{P128}	—	0.91	15.8	—	0.41	7.2	ms	
	8-KB	t _{P8K}	—	60	212	—	27	96	ms	
	32-KB	t _{P32K}	—	234	848	—	106	384	ms	
Erasure time N _{PEC} ≤ 100 times	8-KB	t _{E8K}	—	78	216	—	43	120	ms	
	32-KB	t _{E32K}	—	283	864	—	157	480	ms	
Erasure time N _{PEC} > 100 times	8-KB	t _{E8K}	—	94	260	—	52	144	ms	
	32-KB	t _{E32K}	—	341	1040	—	189	576	ms	
Reprogramming/erasure cycle ^{*4}	N _{PEC}	10000 ^{*1}	—	—	10000 ^{*1}	—	—	—	Times	
Suspend delay during programming	t _{SPD}	—	—	264	—	—	120	—	μs	
Programming resume time	t _{PRT}	—	—	110	—	—	50	—	μs	
First suspend delay during erasure in suspend priority mode	t _{SESD1}	—	—	216	—	—	120	—	μs	
Second suspend delay during erasure in suspend priority mode	t _{SESD2}	—	—	1.7	—	—	1.7	—	ms	
Suspend delay during erasure in erasure priority mode	t _{SEED}	—	—	1.7	—	—	1.7	—	ms	
First erasing resume time during erasure in suspend priority mode ^{*5}	t _{REST1}	—	—	1.7	—	—	1.7	—	ms	
Second erasing resume time during erasure in suspend priority mode	t _{REST2}	—	—	144	—	—	80	—	μs	
Erasing resume time during erasure in erasure priority mode	t _{REET}	—	—	144	—	—	80	—	μs	
Forced stop command	t _{FD}	—	—	32	—	—	20	—	μs	
Data hold time ^{*2}	t _{DRP}	10 ^{*2} *3	—	—	10 ^{*2} *3	—	—	—	Years	Tj = +125°C
		20 ^{*2} *3	—	—	20 ^{*2} *3	—	—	Tj = +105°C		
		30 ^{*2} *3	—	—	30 ^{*2} *3	—	—	Tj = +85°C		

Note 1. This is the minimum number of times to guarantee all the characteristics after reprogramming. The guaranteed range is from 1 to the minimum value.

Note 2. This indicates the minimum value of the characteristic when reprogramming is performed within the specified range.

Note 3. This result is obtained from reliability testing.

Note 4. The reprogram/erase cycle is the number of erasures for each block. When the reprogram/erase cycle is n times (n = 10,000), erasing can be performed n times for each block. For example, when 128-byte programming is performed 64 times for different addresses in 8-KB blocks, and then the entire block is erased, the reprogram/erase cycle is counted as one. However, programming the same address several times as one erasure is not enabled. Overwriting is prohibited.

Note 5. Time for resumption includes time for reapplying the erasing pulse (up to one full pulse) that was cut off at the time of suspension.

Note 6. The reference value at VCC = 3.3V and room temperature.

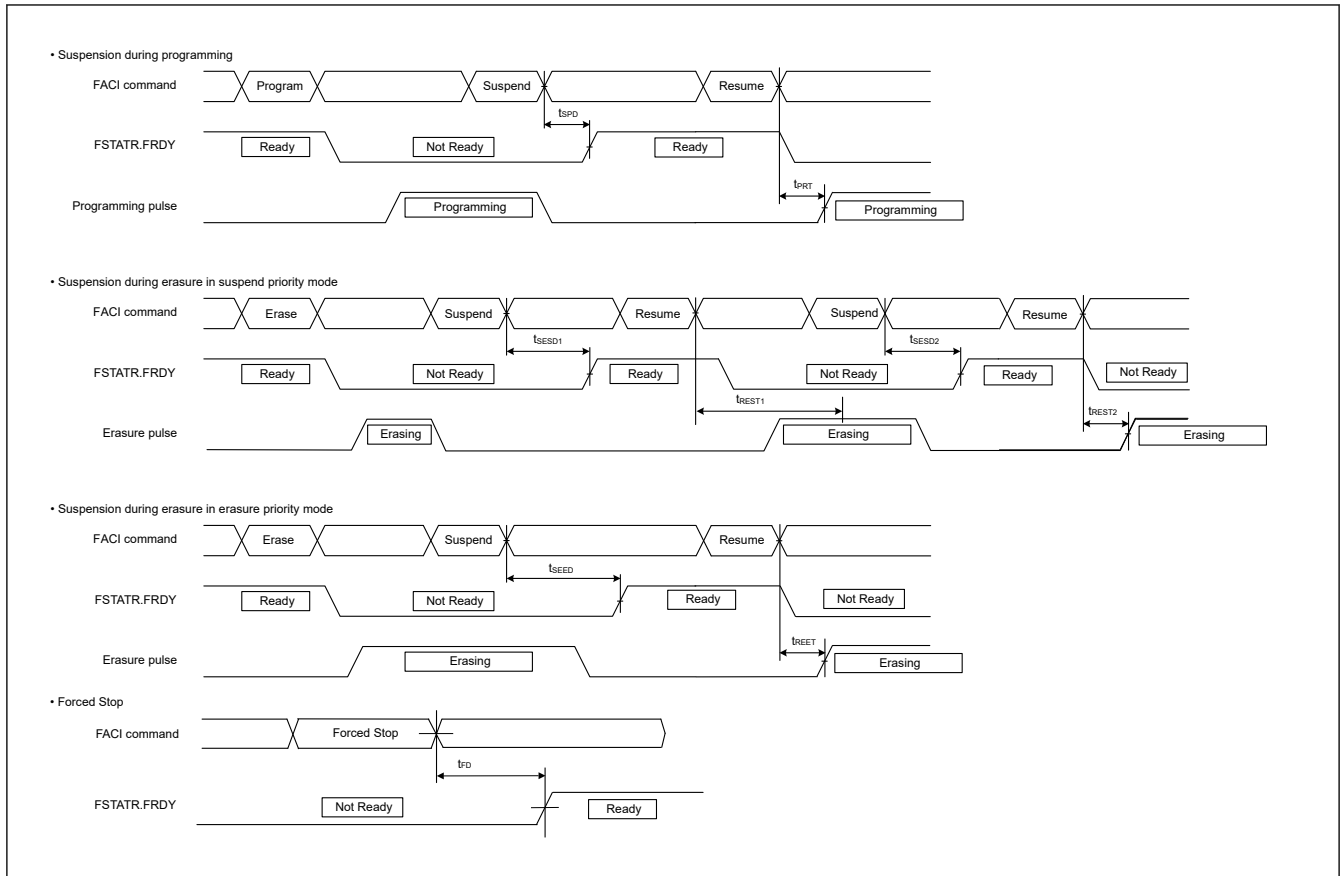

Figure 2.126 Suspension and forced stop timing for flash memory programming and erasure

2.13.2 Data Flash Memory Characteristics

Table 2.84 Data flash memory characteristics (1 of 2)

Conditions: Program or erase: FCLK = 4 to 60 MHz
Read: FCLK ≤ 60 MHz

Parameter	Symbol	FCLK = 4 MHz			20 MHz ≤ FCLK ≤ 60 MHz			Unit	Test conditions
		Min	Typ*6	Max	Min	Typ*6	Max		
Programming time	4-byte	t _{DP4}	—	0.36	3.8	—	0.16	1.7	ms
	8-byte	t _{DP8}	—	0.38	4.0	—	0.17	1.8	
	16-byte	t _{DP16}	—	0.42	4.5	—	0.19	2.0	
Erasure time	64-byte	t _{DE64}	—	3.1	18	—	1.7	10	ms
	128-byte	t _{DE128}	—	4.7	27	—	2.6	15	
	256-byte	t _{DE256}	—	8.9	50	—	4.9	28	
Blank check time	4-byte	t _{DBC4}	—	—	84	—	—	30	μs
Reprogramming/erasure cycle*1	N _{DPEC}	125000*2	—	—	125000*2	—	—	—	—
Suspend delay during programming	4-byte	t _{DSPD}	—	—	264	—	—	120	μs
	8-byte		—	—	264	—	—	120	
	16-byte		—	—	264	—	—	120	
Programming resume time	t _{DPRT}	—	—	110	—	—	50	μs	

Table 2.84 Data flash memory characteristics (2 of 2)

Conditions: Program or erase: FCLK = 4 to 60 MHz
Read: FCLK ≤ 60 MHz

Parameter	Symbol	FCLK = 4 MHz			20 MHz ≤ FCLK ≤ 60 MHz			Unit	Test conditions	
		Min	Typ ^{*6}	Max	Min	Typ ^{*6}	Max			
First suspend delay during erasure in suspend priority mode	64-byte	t _{DSESD1}	—	—	216	—	—	120	μs	
	128-byte		—	—	216	—	—	120		
	256-byte		—	—	216	—	—	120		
Second suspend delay during erasure in suspend priority mode	64-byte	t _{DSESD2}	—	—	300	—	—	300	μs	
	128-byte		—	—	390	—	—	390		
	256-byte		—	—	570	—	—	570		
Suspend delay during erasing in erasure priority mode	64-byte	t _{DSEED}	—	—	300	—	—	300	μs	
	128-byte		—	—	390	—	—	390		
	256-byte		—	—	570	—	—	570		
First erasing resume time during erasure in suspend priority mode ^{*5}	t _{DREST1}	—	—	300	—	—	300	μs		
Second erasing resume time during erasure in suspend priority mode	t _{DREST2}	—	—	126	—	—	70	μs		
First erasing resume time during erasure in suspend priority mode	t _{DREST2}	—	—	126	—	—	70	μs		
Erasing resume time during erasure in erasure priority mode	t _{DREET}	—	—	126	—	—	70	μs		
Forced stop command	t _{FD}	—	—	32	—	—	20	μs		
Data hold time ^{*3}	t _{DRP}	10 ^{*3 *4}	—	—	10 ^{*3 *4}	—	—	Year	T _J = +125°C	
		20 ^{*3 *4}	—	—	20 ^{*3 *4}	—	—			T _J = +105°C
		30 ^{*3 *4}	—	—	30 ^{*3 *4}	—	—			T _J = +85°C

Note 1. The reprogram/erase cycle is the number of erasures for each block. When the reprogram/erase cycle is n times (n = 125,000), erasing can be performed n times for each block. For example, when 4-byte programming is performed 16 times for different addresses in 64-byte blocks, and then the entire block is erased, the reprogram/erase cycle is counted as one. However, programming the same address several times as one erasure is not enabled. Overwriting is prohibited.

Note 2. This is the minimum number of times to guarantee all the characteristics after reprogramming. The guaranteed range is from 1 to the minimum value.

Note 3. This indicates the minimum value of the characteristic when reprogramming is performed within the specified range.

Note 4. This result is obtained from reliability testing.

Note 5. Time for resumption includes time for reapplying the erasing pulse (up to one full pulse) that was cut off at the time of suspension.

Note 6. The reference value at VCC = 3.3 V and room temperature.

2.13.3 Option Setting Memory (Code flash memory) Characteristics

Table 2.85 Option setting memory (Code flash memory) characteristics (1 of 2)

Conditions: Program: FCLK = 4 to 60 MHz
Read: FCLK ≤ 60 MHz

Parameter	Symbol	FCLK = 4 MHz			20 MHz ≤ FCLK ≤ 60 MHz			Unit	Test conditions
		Min	Typ ^{*4}	Max	Min	Typ ^{*4}	Max		
Programming time N _{OPC} ≤ 200 times	t _{OP}	—	83	309	—	45	162	ms	

Table 2.85 Option setting memory (Code flash memory) characteristics (2 of 2)

Conditions: Program: FCLK = 4 to 60 MHz
Read: FCLK ≤ 60 MHz

Parameter	Symbol	FCLK = 4 MHz			20 MHz ≤ FCLK ≤ 60 MHz			Unit	Test conditions
		Min	Typ ^{*4}	Max	Min	Typ ^{*4}	Max		
Programming time N _{OPC} > 200 times	t _{OP}	—	100	371	—	55	195	ms	
Reprogramming cycle	N _{OPC}	20000 ^{*1}	—	—	20000 ^{*1}	—	—	Times	
Data hold time ^{*2}	t _{DRP}	10 ^{*2 *3}	—	—	10 ^{*2 *3}	—	—	Years	T _j = +125°C
		20 ^{*2 *3}	—	—	20 ^{*2 *3}	—	—		T _j = +105°C
		30 ^{*2 *3}	—	—	30 ^{*2 *3}	—	—		T _j = +85°C

Note 1. This is the minimum number of times to guarantee all the characteristics after reprogramming. The guaranteed range is from 1 to the minimum value.

Note 2. This indicates the minimum value of the characteristic when reprogramming is performed within the specified range.

Note 3. This result is obtained from reliability testing.

Note 4. The reference value at VCC = 3.3 V and room temperature.

2.13.4 Option Setting Memory (Data flash memory) Characteristics

Table 2.86 Option Setting Memory (Data flash memory) characteristics

Conditions: Program: FCLK = 4 to 60 MHz
Read: FCLK ≤ 60 MHz

Parameter	Symbol	FCLK = 4 MHz			20 MHz ≤ FCLK ≤ 60 MHz			Unit	Test conditions
		Min	Typ ^{*4}	Max	Min	Typ ^{*4}	Max		
Command time for configuration set (4 / 16 Byte)	t _{DCCCT}	—	68	515	—	35	255	ms	
Update Cycles in Configuration area	N _{cupc}	125000 ^{*1}	—	—	125000 ^{*1}	—	—	Times	
Data hold time ^{*2}	t _{DRP}	10 ^{*2 *3}	—	—	10 ^{*2 *3}	—	—	Years	T _j = +125°C
		20 ^{*2 *3}	—	—	20 ^{*2 *3}	—	—		T _j = +105°C
		30 ^{*2 *3}	—	—	30 ^{*2 *3}	—	—		T _j = +85°C

Note 1. This is the minimum number of times to guarantee all the characteristics after reprogramming. The guaranteed range is from 1 to the minimum value.

Note 2. This indicates the minimum value of the characteristic when reprogramming is performed within the specified range.

Note 3. This result is obtained from reliability testing.

Note 4. The reference value at VCC = 3.3 V and room temperature.

2.13.5 Anti-rollback counter Characteristics

Table 2.87 Anti-rollback counter characteristics (1 of 2)

Conditions: Program: FCLK = 4 to 60 MHz
Read: FCLK ≤ 60 MHz

Parameter	Symbol	FCLK = 4 MHz			20 MHz ≤ FCLK ≤ 60 MHz			Unit	Test conditions
		Min	Typ ^{*4}	Max	Min	Typ ^{*4}	Max		
Command time for increment counter and refresh counter	t _{IRCT}	—	11.9	81	—	6.3	42	ms	
Command time for read counter	t _{RCT}	—	—	25	—	—	5	μs	
Update Cycles (total of increment and refreshing)	N _{cupc}	125000 ^{*1}	—	—	125000 ^{*1}	—	—	Times	

Table 2.87 Anti-rollback counter characteristics (2 of 2)

Conditions: Program: FCLK = 4 to 60 MHz
Read: FCLK ≤ 60 MHz

Parameter	Symbol	FCLK = 4 MHz			20 MHz ≤ FCLK ≤ 60 MHz			Unit	Test conditions
		Min	Typ ^{*4}	Max	Min	Typ ^{*4}	Max		
Data hold time ^{*2}	t _{DRP}	10 ^{*2 *3}	—	—	10 ^{*2 *3}	—	—	Years	T _j = +125°C
		20 ^{*2 *3}	—	—	20 ^{*2 *3}	—	—		T _j = +105°C
		30 ^{*2 *3}	—	—	30 ^{*2 *3}	—	—		T _j = +85°C

Note 1. This is the minimum number of times to guarantee all the characteristics after reprogramming. The guaranteed range is from 1 to the minimum value.

Note 2. This indicates the minimum value of the characteristic when reprogramming is performed within the specified range.

Note 3. This result is obtained from reliability testing.

Note 4. The reference value at VCC = 3.3 V and room temperature.

2.14 Boundary Scan

Table 2.88 Boundary scan characteristics

Parameter	VCC	Symbol	Min	Typ	Max	Unit	Test conditions
TCK clock cycle time	1.68 V or above	t _{TCKcyc}	100	—	—	ns	Figure 2.127
TCK clock high pulse width	1.68 V or above	t _{TCKH}	0.45	—	—	t _{TCKcyc}	
TCK clock low pulse width	1.68 V or above	t _{TCKL}	0.45	—	—	t _{TCKcyc}	
TCK clock rise time	1.68 V or above	t _{TCKr}	—	—	0.05 ^{*2}	t _{TCKcyc}	
TCK clock fall time	1.68 V or above	t _{TCKf}	—	—	0.05 ^{*2}	t _{TCKcyc}	
TMS setup time	1.68 V or above	t _{TMSS}	20	—	—	ns	Figure 2.128
TMS hold time	1.68 V or above	t _{TMSH}	20	—	—	ns	
TDI setup time	1.68 V or above	t _{TDIS}	20	—	—	ns	
TDI hold time	1.68 V or above	t _{TDIH}	20	—	—	ns	
TDO data delay	1.68 V or above	t _{TDOD}	—	—	40	ns	
Capture register setup time	1.68 V or above	t _{CAPTS}	20	—	—	ns	Figure 2.129
Capture register hold time	1.68 V or above	t _{CAPTH}	20	—	—	ns	
Update register delay time	1.68 V or above	t _{UPDATED}	—	—	40	ns	
Boundary scan circuit startup time ^{*1}	1.68 V or above	T _{BSSTUP}	t _{RESWP}	—	—	—	Figure 2.130

Note 1. Boundary scan does not function until the power-on reset becomes negative.

Note 2. 1 μs at the longest

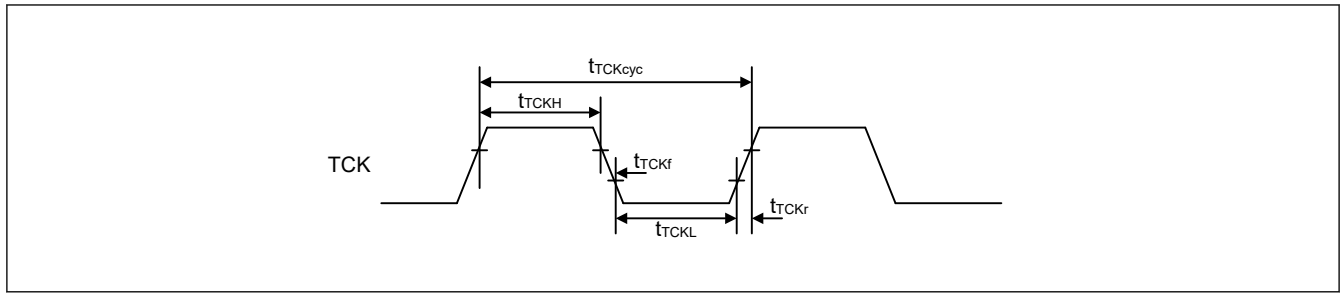

Figure 2.127 Boundary scan TCK timing

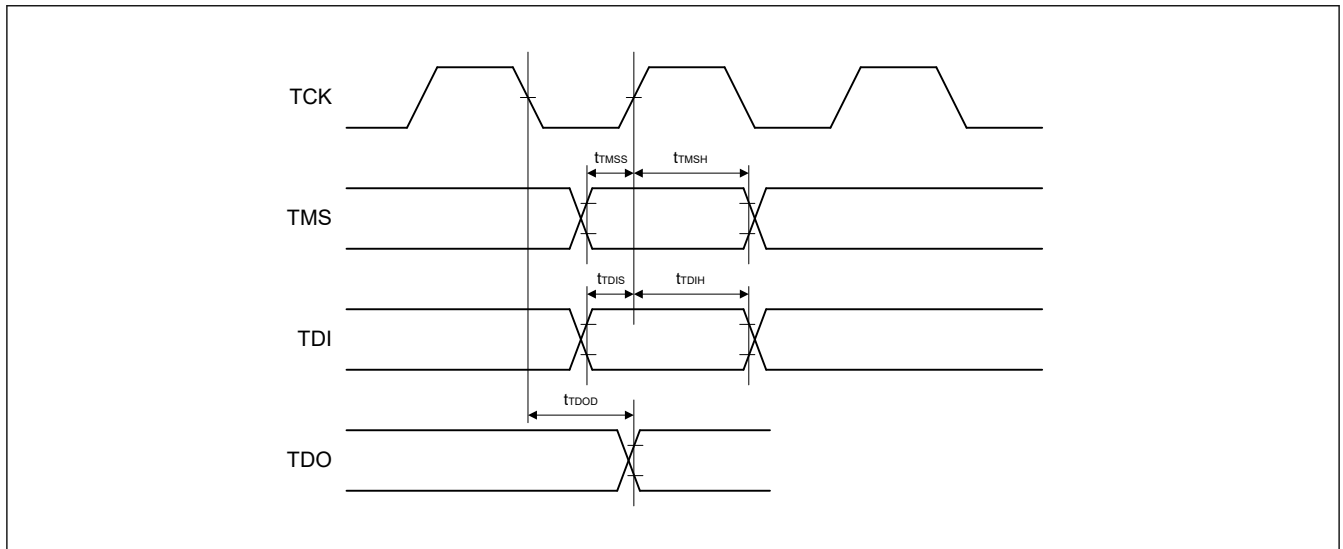

Figure 2.128 Boundary scan input/output timing (1)

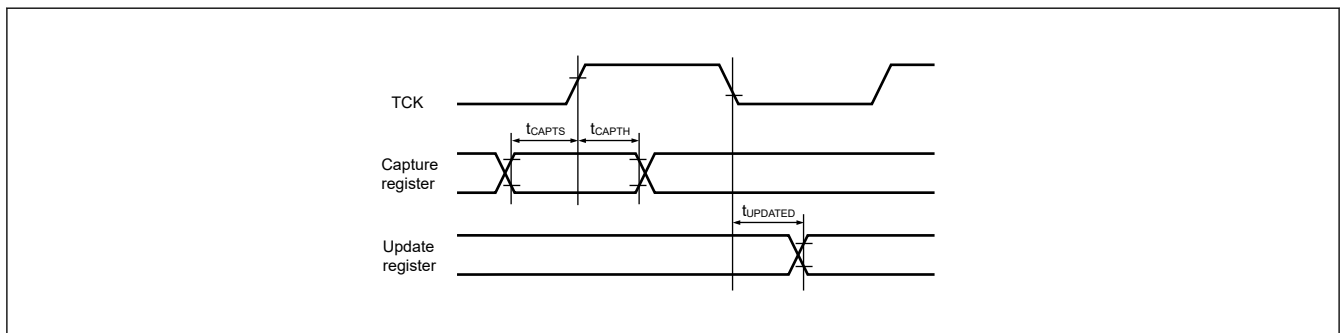

Figure 2.129 Boundary scan input/output timing (2)

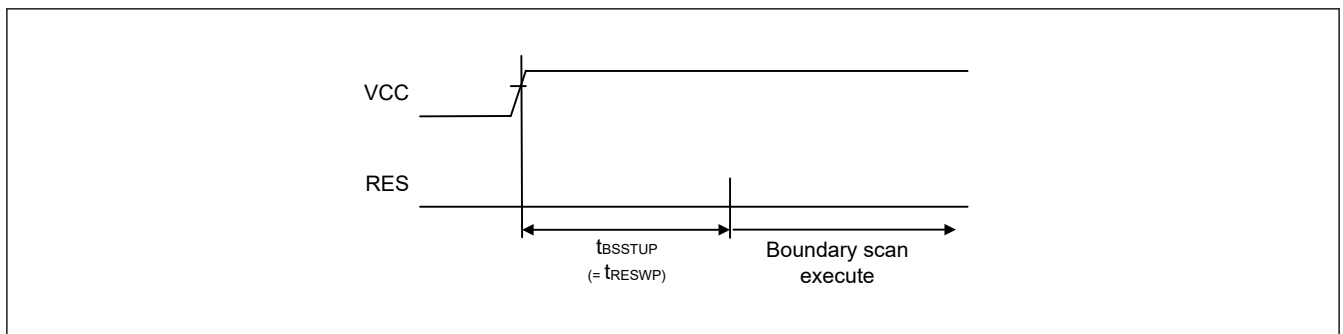

Figure 2.130 Boundary scan circuit startup timing

2.15 Joint European Test Action Group (JTAG)

Table 2.89 JTAG

Parameter	VCC	Symbol	Min	Typ	Max	Unit	Test conditions	
TCK clock cycle time	2.7 V or above	t_{TCKcyc}	40.0	—	—	ns	Figure 2.131	
	1.68 V or above		40.0	—	—	ns		
TCK clock high pulse width	2.7 V or above	t_{TCKH}	0.375	—	—	t_{TCKcyc}		
	1.68 V or above		0.375	—	—	t_{TCKcyc}		
TCK clock low pulse width	2.7 V or above	t_{TCKL}	0.375	—	—	t_{TCKcyc}		
	1.68 V or above		0.375	—	—	t_{TCKcyc}		
TCK clock rise time	2.7 V or above	t_{TCKr}	—	—	0.125 ^{*1}	t_{TCKcyc}		
	1.68 V or above		—	—	0.125 ^{*1}	t_{TCKcyc}		
TCK clock fall time	2.7 V or above	t_{TCKf}	—	—	0.125 ^{*1}	t_{TCKcyc}		
	1.68 V or above		—	—	0.125 ^{*1}	t_{TCKcyc}		
TMS setup time	2.7 V or above	t_{TMSS}	8.0	—	—	ns		Figure 2.132
	1.68 V or above		8.0	—	—	ns		
TMS hold time	2.7 V or above	t_{TMSH}	8.0	—	—	ns		
	1.68 V or above		8.0	—	—	ns		
TDI setup time	2.7 V or above	t_{TDIS}	8.0	—	—	ns		
	1.68 V or above		8.0	—	—	ns		
TDI hold time	2.7 V or above	t_{TDIH}	8.0	—	—	ns		
	1.68 V or above		8.0	—	—	ns		
TDO data delay time	2.7 V or above	t_{TDOD}	—	—	20.0	ns		
	1.68 V or above		—	—	28.0	ns		

Note 1. 1 μ s at the longest

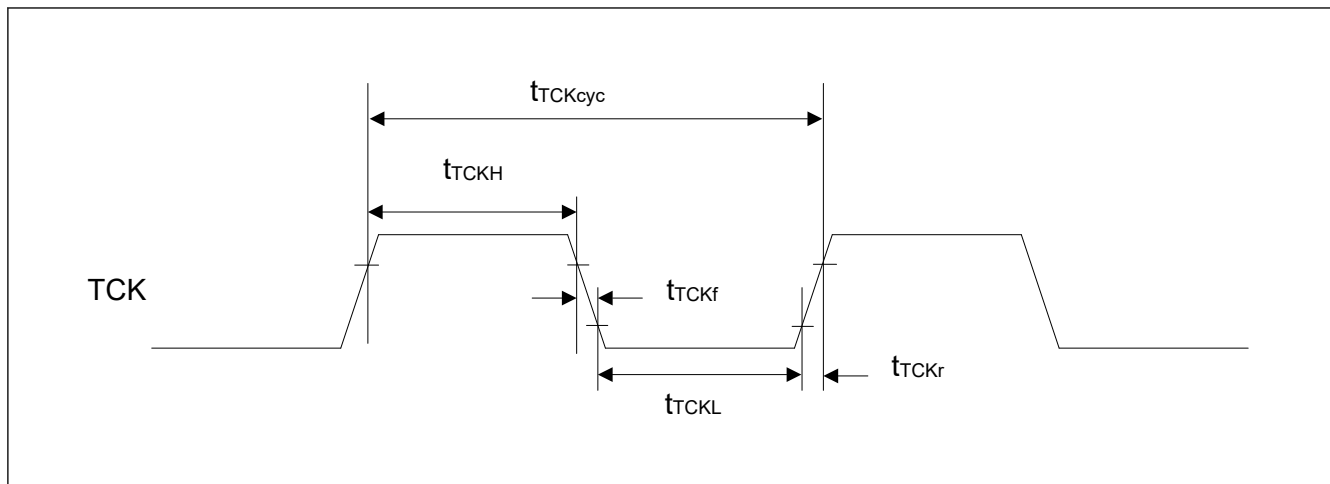

Figure 2.131 JTAG TCK timing

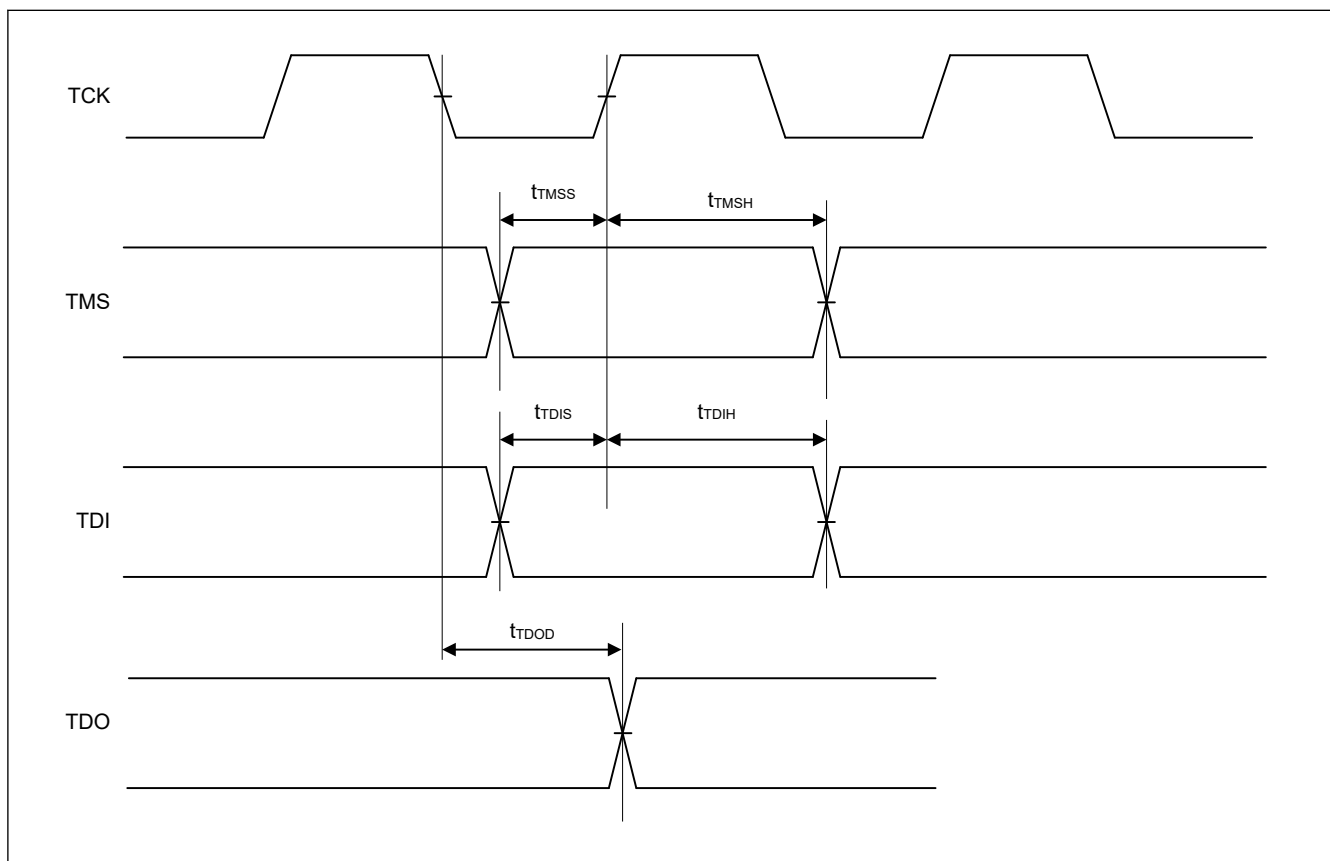

Figure 2.132 JTAG input/output timing

2.16 Serial Wire Debug (SWD)

Table 2.90 SWD

Parameter	VCC	Symbol	Min	Typ	Max	Unit	Test conditions
SWCLK clock cycle time	2.7 V or above	$t_{SWCKcyc}$	40.0	—	—	ns	Figure 2.133
	1.68 V or above		40.0	—	—	ns	
SWCLK clock high pulse width	2.7 V or above	t_{SWCKH}	0.375	—	—	$t_{SWCKcyc}$	
	1.68 V or above		0.375	—	—	$t_{SWCKcyc}$	
SWCLK clock low pulse width	2.7 V or above	t_{SWCKL}	0.375	—	—	$t_{SWCKcyc}$	
	1.68 V or above		0.375	—	—	$t_{SWCKcyc}$	
SWCLK clock rise time	2.7 V or above	t_{SWCKr}	—	—	0.125^{*1}	$t_{SWCKcyc}$	
	1.68 V or above		—	—	0.125^{*1}	$t_{SWCKcyc}$	
SWCLK clock fall time	2.7 V or above	t_{SWCKf}	—	—	0.125^{*1}	$t_{SWCKcyc}$	
	1.68 V or above		—	—	0.125^{*1}	$t_{SWCKcyc}$	
SWDIO setup time	2.7 V or above	t_{SWDS}	8.0	—	—	ns	Figure 2.134
	1.68 V or above		8.0	—	—	ns	
SWDIO hold time	2.7 V or above	t_{SWDH}	8.0	—	—	ns	
	1.68 V or above		8.0	—	—	ns	
SWDIO data delay time	2.7 V or above	t_{SWDD}	2.0	—	28.0	ns	
	1.68 V or above		2.0	—	32.0	ns	

Note 1. 1 μ s at the longest

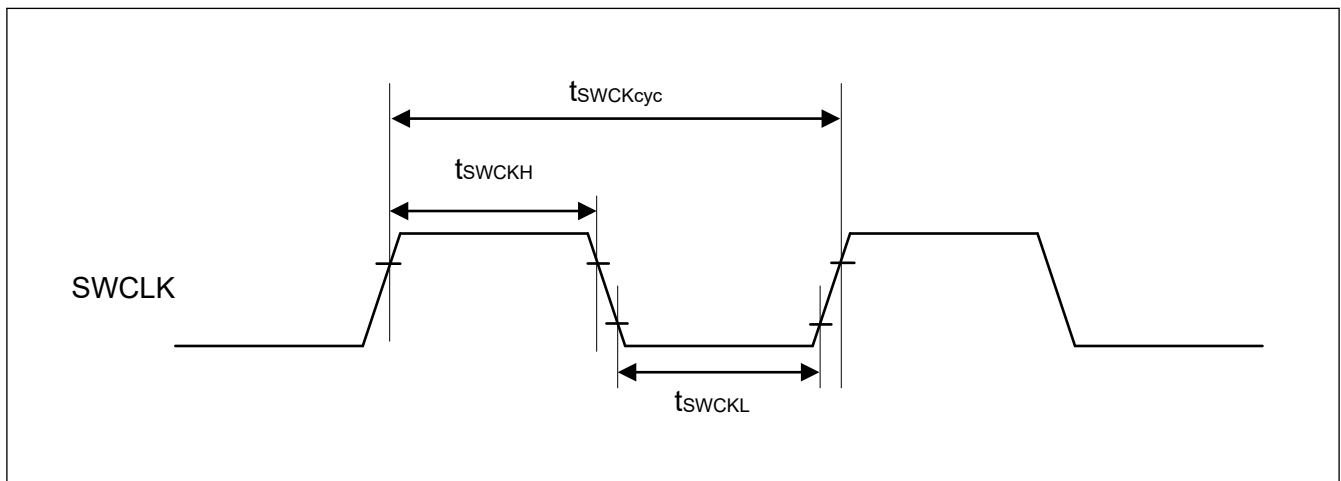

Figure 2.133 SWD SWCLK timing

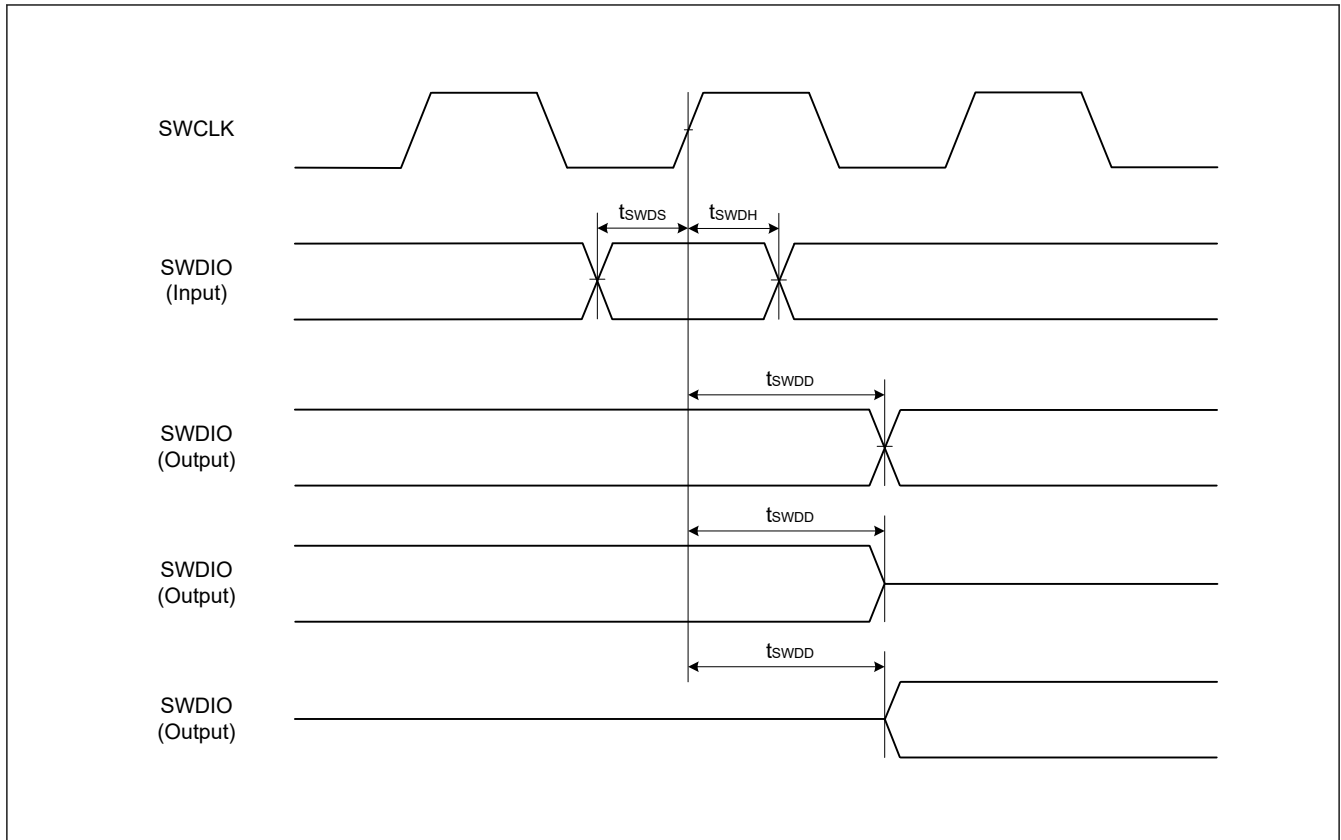

Figure 2.134 SWD input/output timing

2.17 Embedded Trace Macro Interface (ETM)

Table 2.91 ETM (1 of 2)

Conditions: High-speed high drive output is selected in the Port Drive Capability bit in the PmnPFS register.

Parameter	VCC	Symbol	Min	Typ	Max	Unit	Test conditions
TCLK clock cycle time	2.7 V or above	$t_{TCLKcyc}$	16.6	—	—	ns	Figure 2.135
	1.68 V or above		16.6	—	—	ns	
TCLK clock high pulse width	2.7 V or above	t_{TCLKH}	7.3	—	—	ns	
	1.68 V or above		6.3	—	—	ns	
TCLK clock low pulse width	2.7 V or above	t_{TCLKL}	7.3	—	—	ns	
	1.68 V or above		6.3	—	—	ns	
TCLK clock rise time	2.7 V or above	t_{TCLKr}	—	—	1.0	ns	
	1.68 V or above		—	—	2.0	ns	
TCLK clock fall time	2.7 V or above	t_{TCLKf}	—	—	1.0	ns	
	1.68 V or above		—	—	2.0	ns	

Table 2.91 ETM (2 of 2)

Conditions: High-speed high drive output is selected in the Port Drive Capability bit in the PmnPFS register.

Parameter	VCC	Symbol	Min	Typ	Max	Unit	Test conditions
TDATA[3:0] output valid time	2.7 V or above	t_{TRDV}	—	—	$t_{TCLKcyc}/4 + 1.6$	ns	Figure 2.136
	1.68 V or above		—	—	$t_{TCLKcyc}/4 + 1.6$	ns	
TDATA[3:0] output hold time	2.7 V or above	t_{TRDH}	1.5	—	—	ns	
	1.68 V or above		1.5	—	—	ns	

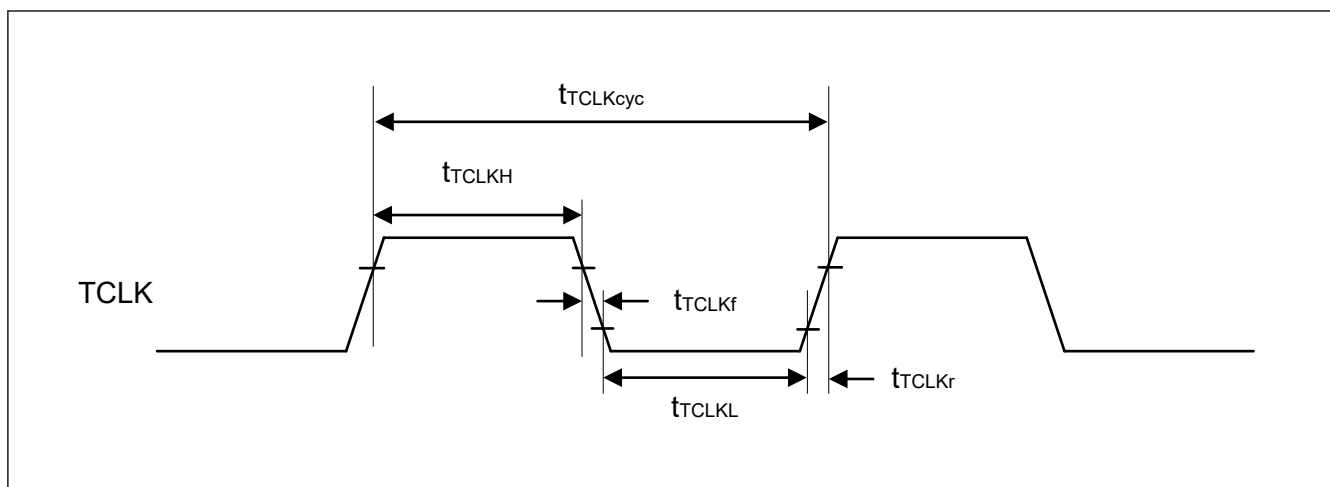

Figure 2.135 ETM TCLK timing

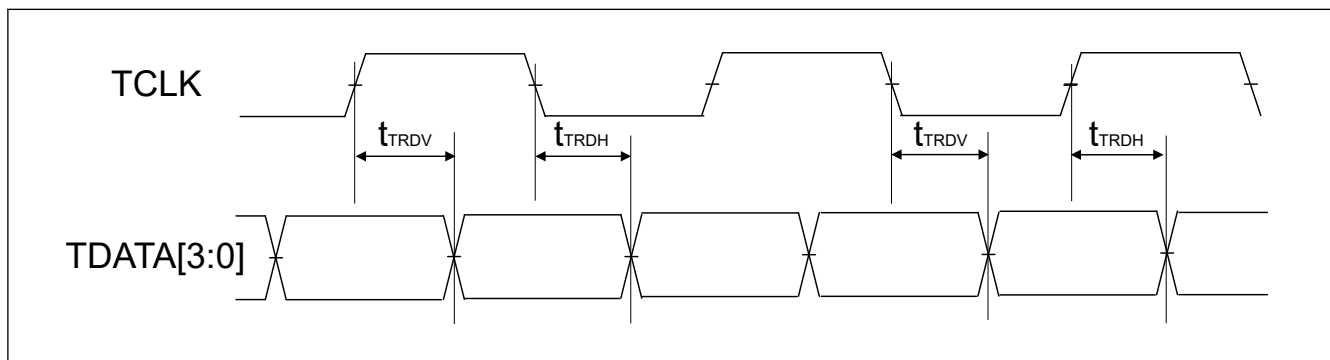

Figure 2.136 ETM output timing

Appendix 1. Port States in Each Processing Mode

Function	Pin function	Reset	Software Standby mode(SSTBY)		Deep Software Standby mode 1,2,3 (DSTBY1,2,3)		After Deep Software Standby mode is canceled (return to startup mode)	
			OPE=0	OPE=1	DSTBY1	DSTBY2/ DSTBY3	IOKEE P = 0	IOKEEP = 1*1
Mode	MD	Pull-up	Keep-I		Keep		Pull-up	Keep
JTAG/SWD	TCK/TMS/TDI/SWCLK	Pull-up	TCK/TDI/TMS/SWCLK input		TCK/TDI/TMS/SWCLK input		TCK/TDI/TMS/SWCLK input	
	TDO	Output	TDO output		TDO output		TDO output	
	SWDIO	Pull-up	SWDIO inout		SWDIO inout		SWDIO inout	
Trace	TCLK/TDATAx/SWO	TCLK/ TDATAx/SWO output	TCLK/TDATAx/SWO output		TCLK/TDATAx/SWO output		TCLK/TDATAx/SWO output	
IRQ	IRQx	Hi-Z	Hi-Z ²		Keep		Hi-Z	Keep
	IRQx-DS (x:Other than 5)	Hi-Z	Hi-Z ²		Keep ^{*3}		Hi-Z	Keep
	IRQ5-DS	Hi-Z	Hi-Z ²		Keep ^{*3}		Hi-Z	
AGT	AGTIO _n	Hi-Z	AGTIO _n inout		Keep		Hi-Z	Keep
	AGTO _n /AGTOA _n / AGTOB _n	Hi-Z	AGTO _n /AGTOA _n /AGTOB _n output		Keep		Hi-Z	Keep
ULPT	ULPTEEn/ULPTEVIn	Hi-Z	ULPTEEn/ULPTEVIn input		Keep		Hi-Z	Keep
	ULPTEEn-DS/ ULPTEVIn-DS	Hi-Z	ULPTEEn-DS/ULPTEVIn-DS input		ULPTEEn-DS/ ULPTEVIn-DS input	Hi-Z	Hi-Z	Keep
	ULPTOn/ ULPTOAn/ ULPTOBn	Hi-Z	ULPTOn/ULPTOAn/ULPTOBn output		Keep		Hi-Z	Keep
	ULPTOn-DS/ ULPTOAn-DS/ ULPTOBn-DS	Hi-Z	ULPTOn/ULPTOAn-DS/ ULPTOBn-DS output		ULPTOn/ ULPTOAn-DS/ ULPTOBn-DS output	Keep	Hi-Z	From DSTBY1: ULPTOn/ ULPTOAn-DS/ ULPTOBn-DS output From DSTBY2,3: Keep
IIC	SCLn/SDAn	Hi-Z	Keep-O ^{*2}		Keep		Hi-Z	Keep
I3C	I3C_SCL0/I3C_SDA0	Hi-Z	Keep-O ^{*2}		Hi-Z		Hi-Z	
USBFS	USB_OVRCURx	Hi-Z	Hi-Z ²		Keep		Hi-Z	Keep
	USB_OVRCURx-DS/ USB_VBUS	Hi-Z	Hi-Z ²		Keep ^{*3}	Keep	Hi-Z	Keep
	USB_DP/USB_DM	Hi-Z	Keep-O ^{*4}		Keep ^{*3}	Keep	Hi-Z	Keep
USBHS	USBHS_OVRCURx	Hi-Z	Hi-Z ²		Keep		Hi-Z	Keep
	USBHS_OVRCURx- DS /USBHS_VBUS	Hi-Z	Hi-Z ²		Keep ^{*3}	Keep	Hi-Z	Keep
	USBHS_DP/ USBHS_DM	Hi-Z	Keep-O ^{*4}		Keep ^{*5}	Keep	Hi-Z	Keep
RTC	RTCICx	Hi-Z	Hi-Z ²		Keep ^{*3}		Hi-Z	Keep
	RTCOU _T	Hi-Z	RTCOU _T output		Keep		Hi-Z	Keep
ACMPHS	VCOUT	Hi-Z	VCOUT output		Keep		Hi-Z	Keep
CLKOUT	CLKOUT	Hi-Z	CLKOUT output		Keep		Hi-Z	Keep
DAC	DAn	Hi-Z	D/A output retained		Hi-Z		Hi-Z	

Function	Pin function	Reset	Software Standby mode(SSTBY)		Deep Software Standby mode 1,2,3 (DSTBY1,2,3)		After Deep Software Standby mode is canceled (return to startup mode)	
			OPE=0	OPE=1	DSTBY1	DSTBY2/ DSTBY3	IOKEE P = 0	IOKEEP = 1 ^{*1}
External bus (CS, SDRAM area)	EBCLK/SDCLK	Hi-Z	High-level output		Keep		Hi-Z	Keep
	Dxx/DQxx	Hi-Z	Hi-Z		Hi-Z		Hi-Z	
	Axx/DQMx	Hi-Z	Hi-Z	Keep-O	Keep		Hi-Z	Keep
	BCx/CSx/RD/WRx/WE	Hi-Z	Hi-Z	High-level output	Keep		Hi-Z	Keep
	ALE	Hi-Z	Hi-Z	Low-level output	Keep		Hi-Z	Keep
	CKE/SDCS/RAS/CAS	Hi-Z	Hi-Z	SDSELF.SFEN = 0: High-level output SDSELF.SFEN = 1: Low-level output	Keep		Hi-Z	Keep
P400/P401	Other than function IRQ5-DS	Hi-Z	Keep-O ^{*2}		Hi-Z		Hi-Z	
Others	—	Hi-Z	Keep-O		Keep		Hi-Z	Keep

Note: Hi-Z: High-impedance

Keep-O: Output pins retain their previous values. Input pins go to high-impedance.

Keep-I: Pin states are retained same as during periods in Normal mode.

Keep: Pin states are retained same as during periods in Software Standby mode.

Note 1. Retains the I/O port state until the DPSBYCR.IOKEEP bit is cleared to 0.

Note 2. Input is enabled if the pin is specified as the Software Standby canceling source while it is used as an external interrupt pin.

Note 3. Input is enabled if the pin is specified as the Deep Software Standby canceling source.

Note 4. Input is enabled while the pin is used as an input pin.

Note 5. For host operation, set the USBHS.SYSCFG.DRPD bit to 1 to enable the USBHS_DP and USBHS_DM pull-down resistors.
For device operation, set the USBHS.SYSCFG.DPRPU bit to 1 to enable the DP pull-up resistor.

Appendix 2. Package Dimensions

Information on the latest version of the package dimensions or mountings is displayed in “Packages” on the Renesas Electronics Corporation website.

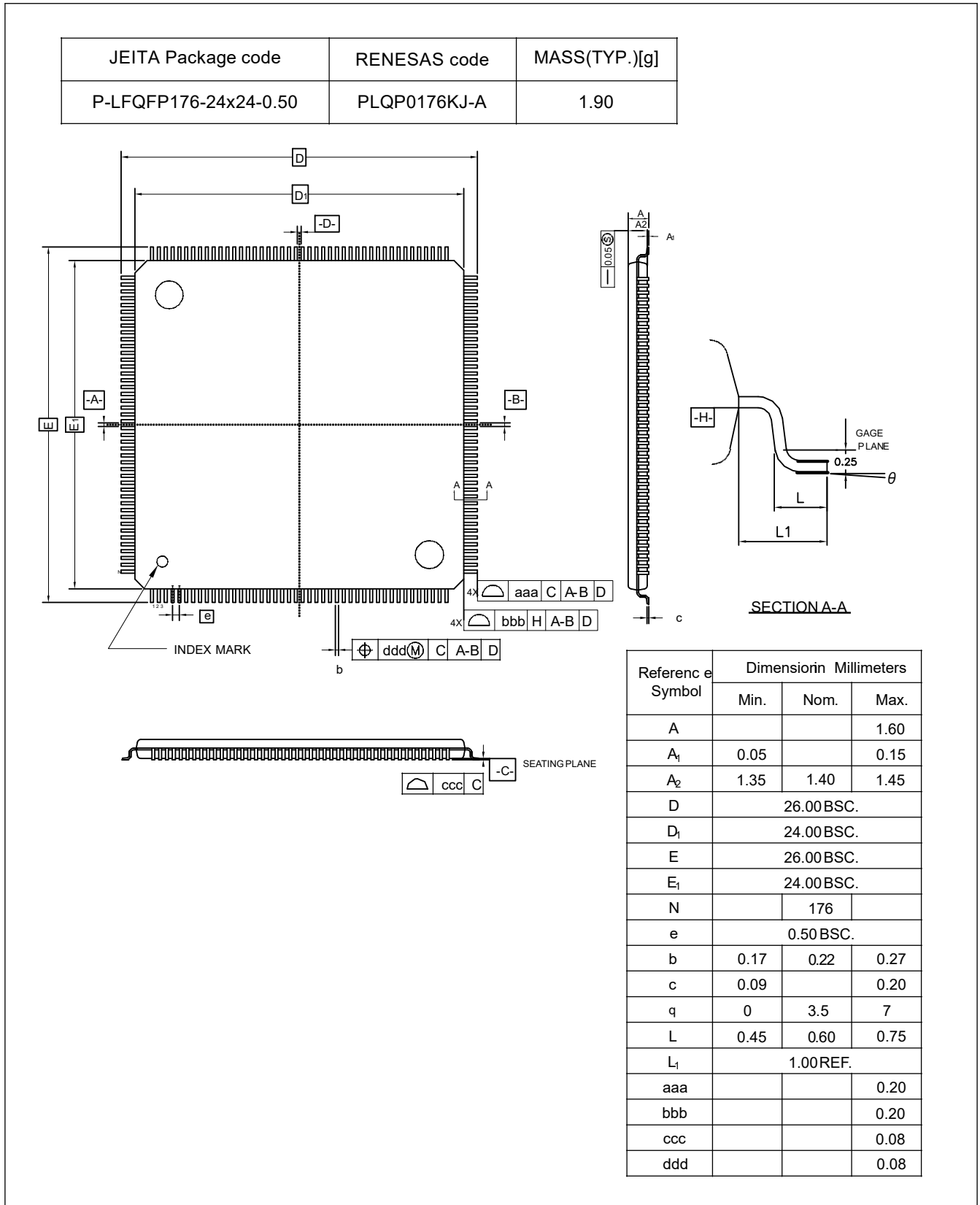
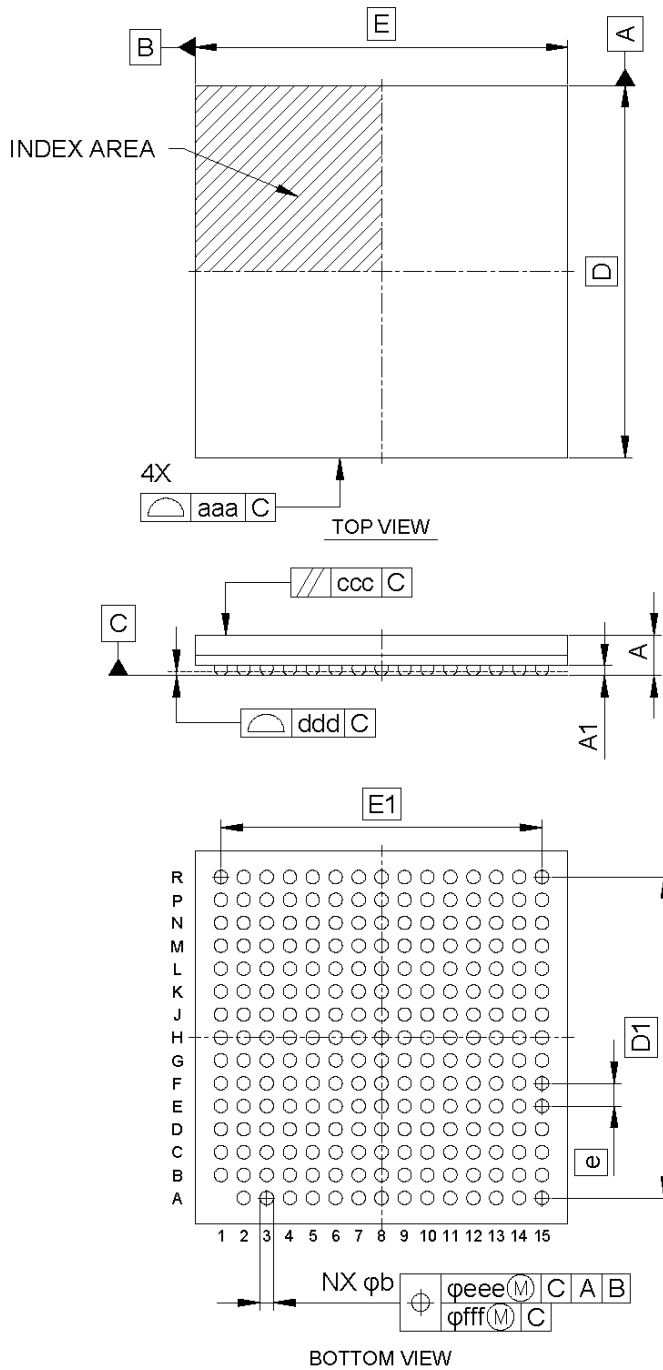

Figure 2.1 LQFP 176-pin

JEITA Package code	RENESAS code	MASS(TYP.)[g]
P-LFBGA224-13x13-0.80	PLBG0224GD-A	0.44



Reference Symbol	Dimension in Millimeters		
	Min.	Nom.	Max.
D	—	13.00	—
E	—	13.00	—
D1	—	11.20	—
E1	—	11.20	—
A	—	—	1.47
A1	0.29	—	—
b	0.42	0.47	0.52
e	—	0.80	—
aaa	—	—	0.15
ccc	—	—	0.20
ddd	—	—	0.12
eee	—	—	0.15
fff	—	—	0.08
N	—	224	—

Figure 2.2 BGA 224-pin

Appendix 3. I/O Registers

This appendix describes I/O register address and access cycles by function.

3.1 Peripheral Base Addresses

This section provides the base addresses for peripherals described in this manual. [Table 3.1](#) shows the name, description, and the base address of each peripheral.

Table 3.1 Peripheral base address (1 of 3)

Description	Name of Secure registers	Base address of Secure registers in Secure alias region	Name of Non-secure registers	Base address of Non-secure registers in Non-secure alias region
Renesas Memory Protection Unit	RMPU	0x4000_0000	RMPU_NS	0x5000_0000
SRAM Control	SRAM	0x4000_2000	SRAM_NS	0x5000_2000
BUS Control	BUS	0x4000_3000	BUS_NS	0x5000_3000
Common Interrupt Controller	ICU_COMMON	0x4000_6000	ICU_COMMON_NS	0x5000_6000
CPU System Security Control Unit	CPSCU	0x4000_8000	CPSCU_NS	0x5000_8000
Direct memory access controller 00	DMAC00	0x4000_A000	DMAC00_NS	0x5000_A000
Direct memory access controller 01	DMAC01	0x4000_A040	DMAC01_NS	0x5000_A040
Direct memory access controller 02	DMAC02	0x4000_A080	DMAC02_NS	0x5000_A080
Direct memory access controller 03	DMAC03	0x4000_A0C0	DMAC03_NS	0x5000_A0C0
Direct memory access controller 04	DMAC04	0x4000_A100	DMAC04_NS	0x5000_A100
Direct memory access controller 05	DMAC05	0x4000_A140	DMAC05_NS	0x5000_A140
Direct memory access controller 06	DMAC06	0x4000_A180	DMAC06_NS	0x5000_A180
Direct memory access controller 07	DMAC07	0x4000_A1C0	DMAC07_NS	0x5000_A1C0
DMAC Module Activation 0	DMA0	0x4000_A800	DMA0_NS	0x5000_A800
Data Transfer Controller 0	DTC0	0x4000_AC00	DTC0_NS	0x5000_AC00
Interrupt Controller	ICU	0x4000_C000	ICU_NS	0x5000_C000
CPU Control Registers	CPU_CTRL	0x4000_F000	CPU_CTRL_NS	0x5000_F000
On-Chip Debug	OCD_CPU	0x4001_1000	OCD_CPU_NS	0x5001_1000
DAP Function	DAP_CPU	0x8001_1000		
Debug Function	CPU_DBG	0x4001_B000	CPU_DBG_NS	0x5001_B000
System Control	SYSC	0x4001_E000	SYSC_NS	0x5001_E000
Temperature Sensor Data	TSD	0x4011_B000	TSD_NS	0x5011_B000
Event Link Controller	ELC	0x4020_1000	ELC_NS	0x5020_1000
Realtime Clock	RTC	0x4020_2000	RTC_NS	0x5020_2000
Independent Watchdog Timer	IWDT	0x4020_2200	IWDT_NS	0x5020_2200
Clock Frequency Accuracy Measurement Circuit	CAC	0x4020_2400	CAC_NS	0x5020_2400
Watchdog Timer 0	WDT0	0x4020_2600	WDT0_NS	0x5020_2600
Module Stop Control A,B,C,D,E	MSTP	0x4020_3000	MSTP_NS	0x5020_3000
Peripheral Security Control Unit	PSCU	0x4020_4000	PSCU_NS	0x5020_4000
Port Output Enable Module for GPT	POEG	0x4021_2000	POEG_NS	0x5021_2000
Ultra-Low Power Timer 0	ULPT0	0x4022_0000	ULPT0_NS	0x5022_0000
Ultra-Low Power Timer 1	ULPT1	0x4022_0100	ULPT1_NS	0x5022_0100

Table 3.1 Peripheral base address (2 of 3)

Description	Name of Secure registers	Base address of Secure registers in Secure alias region	Name of Non-secure registers	Base address of Non-secure registers in Non-secure alias region
Low Power Asynchronous General purpose Timer 0	AGT0	0x4022_1000	AGT0_NS	0x5022_1000
Low Power Asynchronous General purpose Timer 1	AGT1	0x4022_1100	AGT1_NS	0x5022_1100
Temperature Sensor	TSN	0x4023_5000	TSN_NS	0x5023_5000
High-Speed Analog Comparator 0	ACMPHS0	0x4023_6000	ACMPHS0_NS	0x5023_6000
High-Speed Analog Comparator 1	ACMPHS1	0x4023_6100	ACMPHS1_NS	0x5023_6100
USB 2.0 FS Module	USBFS	0x4025_0000	USBFS_NS	0x5025_0000
SD Host Interface 0	SDHI0	0x4025_2000	SDHI0_NS	0x5025_2000
SD Host Interface 1	SDHI1	0x4025_2400	SDHI1_NS	0x5025_2400
Serial Sound Interface Enhanced (SSIE) 0	SSIE0	0x4025_D000	SSIE0_NS	0x5025_D000
Serial Sound Interface Enhanced (SSIE) 1	SSIE1	0x4025_D100	SSIE1_NS	0x5025_D100
Inter-Integrated Circuit 0	IIC0	0x4025_E000	IIC0_NS	0x5025_E000
Inter-Integrated Circuit 0 Wake-up Unit	IIC0WU	0x4025_E014	IIC0WU_NS	0x5025_E014
Inter-Integrated Circuit 1	IIC1	0x4025_E100	IIC1_NS	0x5025_E100
Octal Serial Peripheral Interface 0	OSPI0_B	0x4026_8000	OSPI0_B_NS	0x5026_8000
Decryption On-The-Fly 0	DOTF0	0x4026_8800	DOTF0_NS	0x5026_8800
CRC Calculator	CRC	0x4031_0000	CRC_NS	0x5031_0000
Data Operation Circuit	DOC_B	0x4031_1000	DOC_B_NS	0x5031_1000
General PWM 32-bit Timer 0	GPT320	0x4032_2000	GPT320_NS	0x5032_2000
General PWM 32-bit Timer 1	GPT321	0x4032_2100	GPT321_NS	0x5032_2100
General PWM 32-bit Timer 2	GPT322	0x4032_2200	GPT322_NS	0x5032_2200
General PWM 32-bit Timer 3	GPT323	0x4032_2300	GPT323_NS	0x5032_2300
General PWM 32-bit Timer 4	GPT324	0x4032_2400	GPT324_NS	0x5032_2400
General PWM 32-bit Timer 5	GPT325	0x4032_2500	GPT325_NS	0x5032_2500
General PWM 32-bit Timer 6	GPT326	0x4032_2600	GPT326_NS	0x5032_2600
General PWM 32-bit Timer 7	GPT327	0x4032_2700	GPT327_NS	0x5032_2700
General PWM 16-bit Timer 8	GPT168	0x4032_2800	GPT168_NS	0x5032_2800
General PWM 16-bit Timer 9	GPT169	0x4032_2900	GPT169_NS	0x5032_2900
General PWM 16-bit Timer 10	GPT1610	0x4032_2A00	GPT1610_NS	0x5032_2A00
General PWM 16-bit Timer 11	GPT1611	0x4032_2B00	GPT1611_NS	0x5032_2B00
General PWM 16-bit Timer 12	GPT1612	0x4032_2C00	GPT1612_NS	0x5032_2C00
General PWM 16-bit Timer 13	GPT1613	0x4032_2D00	GPT1613_NS	0x5032_2D00
Output Phase Switching Controller	GPT_OPS	0x4032_3F00	GPT_OPS_NS	0x5032_3F00
12bit A/D Converter 0	ADC120	0x4033_2000	ADC120_NS	0x5033_2000
12bit A/D Converter 1	ADC121	0x4033_2200	ADC121_NS	0x5033_2200
12-bit D/A converter	DAC12	0x4033_3000	DAC12_NS	0x5033_3000
Graphics LCD Controller	GLCDC	0x4034_2000	GLCDC_NS	0x5034_2000

Table 3.1 Peripheral base address (3 of 3)

Description	Name of Secure registers	Base address of Secure registers in Secure alias region	Name of Non-secure registers	Base address of Non-secure registers in Non-secure alias region
2D Drawing Engine	DRW	0x4034_4000	DRW_NS	0x5034_4000
MIPI DSI link	MIPI_DSI	0x4034_6000	MIPI_DSI_NS	0x5034_6000
MIPI PHY	MIPI_PHY0	0x4034_6C00	MIPI_PHY0_NS	0x5034_6C00
Capture Engine Unit	CEU	0x4034_8000	CEU_NS	0x5034_8000
USB 2.0 High-Speed Module	USBHS	0x4035_1000	USBHS_NS	0x5035_1000
DMA Controller for the Ethernet Controller Channel 0	EDMAC0	0x4035_4000	EDMAC0_NS	0x5035_4000
Ethernet Controller Channel 0	ETHERC0	0x4035_4100	ETHERC0_NS	0x5035_4100
Serial Communication Interface 0	SCI0_B	0x4035_8000	SCI0_B_NS	0x5035_8000
Serial Communication Interface 1	SCI1_B	0x4035_8100	SCI1_B_NS	0x5035_8100
Serial Communication Interface 2	SCI2_B	0x4035_8200	SCI2_B_NS	0x5035_8200
Serial Communication Interface 3	SCI3_B	0x4035_8300	SCI3_B_NS	0x5035_8300
Serial Communication Interface 4	SCI4_B	0x4035_8400	SCI4_B_NS	0x5035_8400
Serial Communication Interface 9	SCI9_B	0x4035_8900	SCI9_B_NS	0x5035_8900
Serial Peripheral Interface 0	SPI0	0x4035_C000	SPI0_NS	0x5035_C000
Serial Peripheral Interface 1	SPI1	0x4035_C100	SPI1_NS	0x5035_C100
I3C Bus Interface	I3C	0x4035_F000	I3C_NS	0x5035_F000
Error correction circuit for MBRAM0	ECCMB0	0x4036_F200	ECCMB0_NS	0x5036_F200
Error correction circuit for MBRAM1	ECCMB1	0x4036_F300	ECCMB1_NS	0x5036_F300
CANFD Module 0	CANFD0	0x4038_0000	CANFD0_NS	0x5038_0000
CANFD Module 1	CANFD1	0x4038_2000	CANFD1_NS	0x5038_2000
Port 0 Control Registers	PORT0	0x4040_0000	PORT0_NS	0x5040_0000
Port 1 Control Registers	PORT1	0x4040_0020	PORT1_NS	0x5040_0020
Port 2 Control Registers	PORT2	0x4040_0040	PORT2_NS	0x5040_0040
Port 3 Control Registers	PORT3	0x4040_0060	PORT3_NS	0x5040_0060
Port 4 Control Registers	PORT4	0x4040_0080	PORT4_NS	0x5040_0080
Port 5 Control Registers	PORT5	0x4040_00A0	PORT5_NS	0x5040_00A0
Port 6 Control Registers	PORT6	0x4040_00C0	PORT6_NS	0x5040_00C0
Port 7 Control Registers	PORT7	0x4040_00E0	PORT7_NS	0x5040_00E0
Port 8 Control Registers	PORT8	0x4040_0100	PORT8_NS	0x5040_0100
Port 9 Control Registers	PORT9	0x4040_0120	PORT9_NS	0x5040_0120
Port A Control Registers	PORTA	0x4040_0140	PORTA_NS	0x5040_0140
Port B Control Registers	PORTB	0x4040_0160	PORTB_NS	0x5040_0160
Pmn Pin Function Control Register	PFS	0x4040_0800	PFS_NS	0x5040_0800
Flash Cache	FCACHE	0x4001_C100	FCACHE_NS	0x5001_C100
Data Flash	FLAD	0x4011_C000	FLAD_NS	0x5011_C000
Flash Application Command Interface	FACI	0x4011_E000	FACI_NS	0x5011_E000
Data Flash Security Setting	FDFS	0x2703_0000		

Note: Name = Peripheral name
Description = Peripheral functionality
Base address = Lowest reserved address or address used by the peripheral

3.2 Access Cycles

This section provides access cycle information for the I/O registers described in this manual.

- Registers are grouped by associated module.
- The number of access cycles indicates the number of cycles based on the specified reference clock.
- In the internal I/O area, reserved addresses that are not allocated to registers must not be accessed, otherwise operations cannot be guaranteed.
- The number of I/O access cycles depends on bus cycles of the internal peripheral bus, divided clock synchronization cycles, and wait cycles of each module. Divided clock synchronization cycles differ depending on the frequency ratio between ICLK and PCLK.
- When the frequency of ICLK is equal to that of PCLK, the number of divided clock synchronization cycles is always constant.
- When the frequency of ICLK is greater than that of PCLK, at least 1 PCLK cycle is added to the number of divided clock synchronization cycles.
- The number of write access cycles indicates the number of cycles obtained by non-bufferable write access.

Note: This applies to the number of cycles when access from the CPU does not conflict with the instruction fetching to the external memory or bus access from other bus masters such as DTC or DMAC.

Table 3.2 Access cycles (1 of 3)

Peripheral base address symbol	Address ^{*1}		Number of access cycles					Cycle Unit	Related function
			ICLK = PCLK		ICLK > PCLK ^{*2}				
	From	To	Read	Write	Read	Write			
RMPU, SRAM, BUS, ICU_COMMON, CPSCU, DMAC0n, DMA0, DTC0, ICU, CPU_CTRL	0x4000_0000	0x4001_CFFF	3	2	3	2	ICLK	Renesas Memory Protection Unit, SRAM Control, BUS Control, Common Interrupt Controller, CPU System Security Control Unit, Direct memory access controller 0 n, DMAC Module Activation 0, Data Transfer Controller 0, Interrupt Controller, CPU Control Registers	
CPU_OCD	0x4001_1004	0x4001_1FFF	7	2	7	2	ICLK	On-Chip Debug	
CPU_DBG, FCACHE	0x4000_B000	0x4001_CFFF	3	2	3	2	ICLK	Debug Function, Flash Cache	
SYSC	0x4001_E000	0x4001_E9FF	4	3	2 to 4	1 to 3	PCLK B	System Control	
SYSC	0x4001_EA00	0x4001_ED7F	7	6	5 to 7	4 to 6	PCLK B	System Control	
TSD	0x4011_B17C	0x4011_B17C	4	3	4	3	ICLK	Temperature Sensor Data	
ELC, RTC	0x4020_1000	0x4020_21FF	4	3	2 to 4	1 to 3	PCLK B	Event Link Controller, Realtime Clock	
IWDT	0x4020_2200	0x4020_22FF	4	65	2 to 4	63 to 65	PCLK B	Independent Watchdog Timer	
CAC, WDT0, MSTP, PSCU, POEG	0x4020_2400	0x4021_2FFF	4	3	2 to 4	1 to 3	PCLK B	Clock Frequency Accuracy Measurement Circuit, Watchdog Timer 0, Module Stop Control, Peripheral Security Control Unit, Port Output Enable Module for GPT	
ULPTn	0x4022_0000	0x4022_01FF	6	65	4 to 6	63 to 65	PCLK B	Ultra-Low Power Timer n	
AGTn	0x4022_1000	0x4022_11FF	6	3	4 to 6	1 to 3	PCLK B	Low Power Asynchronous General purpose Timer n	
TSN	0x4023_5000	0x4023_5FFF	4	3	2 to 4	1 to 3	PCLK B	Temperature Sensor	
ACMPHSn	0x4023_6000	0x4023_61FF	3	3	1 to 3	1 to 3	PCLK B	High-Speed Analog Comparator n	
USBFS	0x4025_0000	0x4025_03FF	5	4	3 to 5	2 to 4	PCLK B	USB 2.0 FS Module	

Table 3.2 Access cycles (2 of 3)

Peripheral base address symbol	Address ^{*1}		Number of access cycles				Cycle Unit	Related function
			ICLK = PCLK		ICLK > PCLK ^{*2}			
	From	To	Read	Write	Read	Write		
USBFS	0x4025_0400	0x4025_04FF	4	65	2 to 4	63 to 65	PCLK B	USB 2.0 FS Module
SDHIn, SSIEn, IICn, OSPIO, DOTF0	0x4025_2000	0x4026_88FF	4	3	2 to 4	1 to 3	PCLK B	SD Host Interface n, Serial Sound Interface Enhanced n, Inter-Integrated Circuit n, Octal Serial Peripheral Interface 0, Decryption On-The-Fly 0
CRC, DOC	0x4031_0000	0x4031_1FFF	4	3	2 to 4	1 to 3	PCLK A	CRC Calculator, Data Operation Circuit
GPT32n, GPT16n, GPT_OPS	0x4032_2000	0x4032_3FFF	7	4	5 to 7	2 to 4	PCLK A	General PWM 32-Bit Timer n, General PWM 16-Bit Timer n, Output Phase Switching Controller
ADC12n, DAC12n, GLCDC, DRW, MIPI_DSI, MIPI_PHY0	0x4033_2000	0x4034_6FFF	4	3	2 to 4	1 to 3	PCLK A	12-bit A/D Converter n, 12-bit D/A Converter n, Graphic LCD Controller, MIPI DSI link, MIPI PHY
CEU	0x4034_8000	0x4034_FFFF	7	5	5 to 7	3 to 5	PCLK A	Capture Engine Unit
USBHS ^{*3}	0x4035_1000	0x4035_115F	BWAIT+4	BWAIT+3	(BWAIT +2) to (BWAIT +4)	(BWAIT +1) to (BWAIT +3)	PCLK A	USB 2.0 High-Speed Module
USBHS ^{*3}	0x4035_1160	0x4035_1167	BWAIT+4	130	(BWAIT +2) to (BWAIT +4)	128 to 130	PCLK A	USB 2.0 High-Speed Module
USBHS	0x4035_1168	0x4035_116F	8	130	6 to 8	128 to 130	PCLK A	USB 2.0 High-Speed Module
EDMAC0	0x4035_4000	0x4035_40FF	5	4	3 to 5	2 to 4	PCLK A	DMA Controller for the Ethernet Controller Channel 0
ETHERC0	0x4035_4100	0x4035_43FF	14	13	12 to 14	11 to 13	PCLK A	Ethernet Controller Channel 0
SCIn, SPIn, I3C	0x4035_8000	0x4035_FFFF	4	3	2 to 4	1 to 3	PCLK A	Serial Communication Interface n, Serial Peripheral Interface n, I3C Bus Interface
ECCMBn	0x4036_F200	0x4036_F3FF	5	4	3 to 5	2 to 4	PCLK A	Error correction circuit for MBRAMn
CANFDn	0x4038_0000	0x4038_3FFF	4	3	2 to 4	1 to 3	PCLK A	CANFD Module n
PORTn	0x4040_0000	0x4040_01FF	4	2	4	2	ICLK	Port n Control Registers
PFS	0x4040_0800	0x4040_0FFF	8	2	8	2	ICLK	Pmn Pin Function Control Register
RSIP-E51A	—	—	1 to 3	2	1 to 3	1 to 2	PCLK A	Renesas Security IP

Table 3.2 Access cycles (3 of 3)

Peripheral base address symbol	Address ^{*1}		Number of access cycles				Cycle Unit	Related function
			ICLK = FCLK		ICLK > FCLK ^{*2}			
	From	To	Read	Write	Read	Write		
FLAD, FACI	0x4011_C040	0x4011_EFFF	4	3	4	3	FCLK	Data Flash, Flash Application Command Interface

Note 1. This table only shows secure address. Access cycle of the non-secure address is the same as its secure address.

Note 2. If the number of PCLK or FCLK cycles is non-integer (for example 1.5), the minimum value is without the decimal point, and the maximum value is rounded up to the decimal point. For example, 1.5 to 2.5 is 1 to 3.

Note 3. BWAIT is the number of waits (not cycles) described in the USBHS.BUSWAIT register.

Appendix 4. Note for Register R/W

- A secure bus master issues a "secure access" using an address marked as secure by IDAU/SAU or MSAU.
- A secure bus master issues a "non-secure access" using an address marked as non-secure by IDAU/SAU or MSAU.
- A non-secure bus master issues a "non-secure access" using an address marked as non-secure by IDAU/SAU or MSAU.

Table 4.1 Type of Register Notes(S-TYPE)

TYPE	UM Description
S-TYPE-1	Only Secure access can write to this register. Read access is always allowed. Non-secure write access is ignored, but TrustZone access error is not generated.
S-TYPE-2	Read access is always allowed If the security attribution is configured as Secure, <ul style="list-style-type: none"> • Secure write access is allowed. • Non-secure write access is ignored, but TrustZone access error is not generated.
	If the security attribution is configured as Non-secure, <ul style="list-style-type: none"> • Secure write access is ignored, but TrustZone access error is not generated. • Non-secure access is allowed.
S-TYPE-3	If the security attribution is configured as Secure, <ul style="list-style-type: none"> • Secure access is allowed. • Non-secure write access is ignored and Non-secure read access is read as 0, TrustZone access error is generated
	If the security attribution is configured as Non-secure, <ul style="list-style-type: none"> • Secure write access is ignored and Secure read access is read as 0, TrustZone access error is generated. • Non-secure access is allowed
S-TYPE-4	If the security attribution is configured as Secure, <ul style="list-style-type: none"> • Secure access is allowed • Non-secure write access is ignored and Non-secure read access is read as 0, but TrustZone access error is not generated.
	If the security attribution is configured as Non-secure, <ul style="list-style-type: none"> • Secure write access is ignored and Secure read access is read as 0, but TrustZone access error is not generated. • Non-secure access is allowed.
S-TYPE-5	No note required.
S-TYPE-6	Secure access is allowed. Non-secure write access is ignored, and Non-secure read access is read as 0, TrustZone access error is generated.
S-TYPE-7	Secure write access is ignored, and Secure read access is read as 0, TrustZone access error is generated. Non-secure access is allowed.

Note: A non-secure bus master does NOT issue any access using an address marked as secure by IDAU/SAU or MSAU.

Table 4.2 Type of Register Notes(P-TYPE)

TYPE	UM Description
P-TYPE-1	Privileged write access is allowed. Read access is always allowed. Unprivileged write access is ignored, but TrustZone access error is not generated.
P-TYPE-2	Privileged access is allowed. Unprivileged write access is ignored, and Unprivileged read access is read as 0, TrustZone access error is generated.
P-TYPE-3	If the privilege attribution is configured as Privileged, <ul style="list-style-type: none"> • Privileged access is allowed. • Unprivileged write access is ignored and Unprivileged read access is read as 0, TrustZone access error is generated.
	If the privilege attribution is configured as Unprivilege, <ul style="list-style-type: none"> • Privileged access and Unprivileged access are allowed.
P-TYPE-4	If the privilege attribution is configured as Privileged, <ul style="list-style-type: none"> • Privileged access is allowed. • Unprivileged write access is ignored and Unprivileged read access is read as 0, TrustZone access error is not generated.
	If the privilege attribution is configured as Unprivilege, <ul style="list-style-type: none"> • Privileged access and Unprivileged access are allowed.
P-TYPE-5	No note required.

Revision History

Revision 1.10 — December 5, 2023

First edition, issued

General Precautions in the Handling of Microprocessing Unit and Microcontroller Unit Products

The following usage notes are applicable to all Microprocessing unit and Microcontroller unit products from Renesas. For detailed usage notes on the products covered by this document, refer to the relevant sections of the document as well as any technical updates that have been issued for the products.

1. Precaution against Electrostatic Discharge (ESD)

A strong electrical field, when exposed to a CMOS device, can cause destruction of the gate oxide and ultimately degrade the device operation. Steps must be taken to stop the generation of static electricity as much as possible, and quickly dissipate it when it occurs. Environmental control must be adequate. When it is dry, a humidifier should be used. This is recommended to avoid using insulators that can easily build up static electricity.

Semiconductor devices must be stored and transported in an anti-static container, static shielding bag or conductive material. All test and measurement tools including work benches and floors must be grounded. The operator must also be grounded using a wrist strap. Semiconductor devices must not be touched with bare hands. Similar precautions must be taken for printed circuit boards with mounted semiconductor devices.

2. Processing at power-on

The state of the product is undefined at the time when power is supplied. The states of internal circuits in the LSI are indeterminate and the states of register settings and pins are undefined at the time when power is supplied. In a finished product where the reset signal is applied to the external reset pin, the states of pins are not guaranteed from the time when power is supplied until the reset process is completed. In a similar way, the states of pins in a product that is reset by an on-chip power-on reset function are not guaranteed from the time when power is supplied until the power reaches the level at which resetting is specified.

3. Input of signal during power-off state

Do not input signals or an I/O pull-up power supply while the device is powered off. The current injection that results from input of such a signal or I/O pull-up power supply may cause malfunction and the abnormal current that passes in the device at this time may cause degradation of internal elements. Follow the guideline for input signal during power-off state as described in your product documentation.

4. Handling of unused pins

Handle unused pins in accordance with the directions given under handling of unused pins in the manual. The input pins of CMOS products are generally in the high-impedance state. In operation with an unused pin in the open-circuit state, extra electromagnetic noise is induced in the vicinity of the LSI, an associated shoot-through current flows internally, and malfunctions occur due to the false recognition of the pin state as an input signal become possible.

5. Clock signals

After applying a reset, only release the reset line after the operating clock signal becomes stable. When switching the clock signal during program execution, wait until the target clock signal is stabilized. When the clock signal is generated with an external resonator or from an external oscillator during a reset, ensure that the reset line is only released after full stabilization of the clock signal. Additionally, when switching to a clock signal produced with an external resonator or by an external oscillator while program execution is in progress, wait until the target clock signal is stable.

6. Voltage application waveform at input pin

Waveform distortion due to input noise or a reflected wave may cause malfunction. If the input of the CMOS device stays in the area between V_{IL} (Max.) and V_{IH} (Min.) due to noise, for example, the device may malfunction. Take care to prevent chattering noise from entering the device when the input level is fixed, and also in the transition period when the input level passes through the area between V_{IL} (Max.) and V_{IH} (Min.).

7. Prohibition of access to reserved addresses

Access to reserved addresses is prohibited. The reserved addresses are provided for possible future expansion of functions. Do not access these addresses as the correct operation of the LSI is not guaranteed.

8. Differences between products

Before changing from one product to another, for example to a product with a different part number, confirm that the change will not lead to problems. The characteristics of a microprocessing unit or microcontroller unit products in the same group but having a different part number might differ in terms of internal memory capacity, layout pattern, and other factors, which can affect the ranges of electrical characteristics, such as characteristic values, operating margins, immunity to noise, and amount of radiated noise. When changing to a product with a different part number, implement a system-evaluation test for the given product.

Notice

1. Descriptions of circuits, software and other related information in this document are provided only to illustrate the operation of semiconductor products and application examples. You are fully responsible for the incorporation or any other use of the circuits, software, and information in the design of your product or system. Renesas Electronics disclaims any and all liability for any losses and damages incurred by you or third parties arising from the use of these circuits, software, or information.
2. Renesas Electronics hereby expressly disclaims any warranties against and liability for infringement or any other claims involving patents, copyrights, or other intellectual property rights of third parties, by or arising from the use of Renesas Electronics products or technical information described in this document, including but not limited to, the product data, drawings, charts, programs, algorithms, and application examples.
3. No license, express, implied or otherwise, is granted hereby under any patents, copyrights or other intellectual property rights of Renesas Electronics or others.
4. You shall be responsible for determining what licenses are required from any third parties, and obtaining such licenses for the lawful import, export, manufacture, sales, utilization, distribution or other disposal of any products incorporating Renesas Electronics products, if required.
5. You shall not alter, modify, copy, or reverse engineer any Renesas Electronics product, whether in whole or in part. Renesas Electronics disclaims any and all liability for any losses or damages incurred by you or third parties arising from such alteration, modification, copying or reverse engineering.
6. Renesas Electronics products are classified according to the following two quality grades: "Standard" and "High Quality". The intended applications for each Renesas Electronics product depends on the product's quality grade, as indicated below.
 - "Standard": Computers; office equipment; communications equipment; test and measurement equipment; audio and visual equipment; home electronic appliances; machine tools; personal electronic equipment; industrial robots; etc.
 - "High Quality": Transportation equipment (automobiles, trains, ships, etc.); traffic control (traffic lights); large-scale communication equipment; key financial terminal systems; safety control equipment; etc.Unless expressly designated as a high reliability product or a product for harsh environments in a Renesas Electronics data sheet or other Renesas Electronics document, Renesas Electronics products are not intended or authorized for use in products or systems that may pose a direct threat to human life or bodily injury (artificial life support devices or systems; surgical implantations; etc.), or may cause serious property damage (space system; undersea repeaters; nuclear power control systems; aircraft control systems; key plant systems; military equipment; etc.). Renesas Electronics disclaims any and all liability for any damages or losses incurred by you or any third parties arising from the use of any Renesas Electronics product that is inconsistent with any Renesas Electronics data sheet, user's manual or other Renesas Electronics document.
7. No semiconductor product is absolutely secure. Notwithstanding any security measures or features that may be implemented in Renesas Electronics hardware or software products, Renesas Electronics shall have absolutely no liability arising out of any vulnerability or security breach, including but not limited to any unauthorized access to or use of a Renesas Electronics product or a system that uses a Renesas Electronics product. RENESAS ELECTRONICS DOES NOT WARRANT OR GUARANTEE THAT RENESAS ELECTRONICS PRODUCTS, OR ANY SYSTEMS CREATED USING RENESAS ELECTRONICS PRODUCTS WILL BE INVULNERABLE OR FREE FROM CORRUPTION, ATTACK, VIRUSES, INTERFERENCE, HACKING, DATA LOSS OR THEFT, OR OTHER SECURITY INTRUSION ("Vulnerability Issues"). RENESAS ELECTRONICS DISCLAIMS ANY AND ALL RESPONSIBILITY OR LIABILITY ARISING FROM OR RELATED TO ANY VULNERABILITY ISSUES. FURTHERMORE, TO THE EXTENT PERMITTED BY APPLICABLE LAW, RENESAS ELECTRONICS DISCLAIMS ANY AND ALL WARRANTIES, EXPRESS OR IMPLIED, WITH RESPECT TO THIS DOCUMENT AND ANY RELATED OR ACCOMPANYING SOFTWARE OR HARDWARE, INCLUDING BUT NOT LIMITED TO THE IMPLIED WARRANTIES OF MERCHANTABILITY, OR FITNESS FOR A PARTICULAR PURPOSE.
8. When using Renesas Electronics products, refer to the latest product information (data sheets, user's manuals, application notes, "General Notes for Handling and Using Semiconductor Devices" in the reliability handbook, etc.), and ensure that usage conditions are within the ranges specified by Renesas Electronics with respect to maximum ratings, operating power supply voltage range, heat dissipation characteristics, installation, etc. Renesas Electronics disclaims any and all liability for any malfunctions, failure or accident arising out of the use of Renesas Electronics products outside of such specified ranges.
9. Although Renesas Electronics endeavors to improve the quality and reliability of Renesas Electronics products, semiconductor products have specific characteristics, such as the occurrence of failure at a certain rate and malfunctions under certain use conditions. Unless designated as a high reliability product or a product for harsh environments in a Renesas Electronics data sheet or other Renesas Electronics document, Renesas Electronics products are not subject to radiation resistance design. You are responsible for implementing safety measures to guard against the possibility of bodily injury, injury or damage caused by fire, and/or danger to the public in the event of a failure or malfunction of Renesas Electronics products, such as safety design for hardware and software, including but not limited to redundancy, fire control and malfunction prevention, appropriate treatment for aging degradation or any other appropriate measures. Because the evaluation of microcomputer software alone is very difficult and impractical, you are responsible for evaluating the safety of the final products or systems manufactured by you.
10. Please contact a Renesas Electronics sales office for details as to environmental matters such as the environmental compatibility of each Renesas Electronics product. You are responsible for carefully and sufficiently investigating applicable laws and regulations that regulate the inclusion or use of controlled substances, including without limitation, the EU RoHS Directive, and using Renesas Electronics products in compliance with all these applicable laws and regulations. Renesas Electronics disclaims any and all liability for damages or losses occurring as a result of your noncompliance with applicable laws and regulations.
11. Renesas Electronics products and technologies shall not be used for or incorporated into any products or systems whose manufacture, use, or sale is prohibited under any applicable domestic or foreign laws or regulations. You shall comply with any applicable export control laws and regulations promulgated and administered by the governments of any countries asserting jurisdiction over the parties or transactions.
12. It is the responsibility of the buyer or distributor of Renesas Electronics products, or any other party who distributes, disposes of, or otherwise sells or transfers the product to a third party, to notify such third party in advance of the contents and conditions set forth in this document.
13. This document shall not be reprinted, reproduced or duplicated in any form, in whole or in part, without prior written consent of Renesas Electronics.
14. Please contact a Renesas Electronics sales office if you have any questions regarding the information contained in this document or Renesas Electronics products.

(Note1) "Renesas Electronics" as used in this document means Renesas Electronics Corporation and also includes its directly or indirectly controlled subsidiaries.

(Note2) "Renesas Electronics product(s)" means any product developed or manufactured by or for Renesas Electronics.

(Rev.5.0-1 October 2020)

Corporate Headquarters

TOYOSU FORESIA, 3-2-24 Toyosu,
Koto-ku, Tokyo 135-0061, Japan
www.renesas.com

Trademarks

Renesas and the Renesas logo are trademarks of Renesas Electronics Corporation. All trademarks and registered trademarks are the property of their respective owners.

Contact Information

For further information on a product, technology, the most up-to-date version of a document, or your nearest sales office, please visit:
www.renesas.com/contact/