

How to Use IC for RS-232 Line Driver/Receivers

***μ*PD4711B**

***μ*PD4712C/4712D**

***μ*PD4713A**

***μ*PD4714A**

***μ*PD4715A**

***μ*PD4721**

***μ*PD4722**

***μ*PD4723**

***μ*PD4724**

***μ*PD4726**

[MEMO]

- **The information in this document is subject to change without notice. Before using this document, please confirm that this is the latest version.**
 - **Not all devices/types available in every country. Please check with local NEC representative for availability and additional information.**
 - No part of this document may be copied or reproduced in any form or by any means without the prior written consent of NEC Corporation. NEC Corporation assumes no responsibility for any errors which may appear in this document.
 - NEC Corporation does not assume any liability for infringement of patents, copyrights or other intellectual property rights of third parties by or arising from use of a device described herein or any other liability arising from use of such device. No license, either express, implied or otherwise, is granted under any patents, copyrights or other intellectual property rights of NEC Corporation or others.
 - Descriptions of circuits, software, and other related information in this document are provided for illustrative purposes in semiconductor product operation and application examples. The incorporation of these circuits, software, and information in the design of the customer's equipment shall be done under the full responsibility of the customer. NEC Corporation assumes no responsibility for any losses incurred by the customer or third parties arising from the use of these circuits, software, and information.
 - While NEC Corporation has been making continuous effort to enhance the reliability of its semiconductor devices, the possibility of defects cannot be eliminated entirely. To minimize risks of damage or injury to persons or property arising from a defect in an NEC semiconductor device, customers must incorporate sufficient safety measures in its design, such as redundancy, fire-containment, and anti-failure features.
 - NEC devices are classified into the following three quality grades:
"Standard", "Special", and "Specific". The Specific quality grade applies only to devices developed based on a customer designated "quality assurance program" for a specific application. The recommended applications of a device depend on its quality grade, as indicated below. Customers must check the quality grade of each device before using it in a particular application.
 - Standard: Computers, office equipment, communications equipment, test and measurement equipment, audio and visual equipment, home electronic appliances, machine tools, personal electronic equipment and industrial robots
 - Special: Transportation equipment (automobiles, trains, ships, etc.), traffic control systems, anti-disaster systems, anti-crime systems, safety equipment and medical equipment (not specifically designed for life support)
 - Specific: Aircraft, aerospace equipment, submersible repeaters, nuclear reactor control systems, life support systems or medical equipment for life support, etc.
- The quality grade of NEC devices is "Standard" unless otherwise specified in NEC's Data Sheets or Data Books. If customers intend to use NEC devices for applications other than those specified for Standard quality grade, they should contact an NEC sales representative in advance.

[MEMO]

CONTENTS

1. INTRODUCTION.....	7
2. FEATURES OF ICS FOR RS-232 LINE DRIVER/RECEIVERS	7
3. SERIES LINEUP	8
3.1 Selection Guide	8
3.2 Ordering Information	8
4. PACKAGE DRAWINGS, PIN CONFIGURATIONS, AND FUNCTIONAL BLOCK DIAGRAMS.....	9
4.1 Package Drawings	9
4.2 Pin Configurations	14
4.3 Functional Block Diagrams.....	17
5. BASIC OPERATIONS	18
5.1 Basic Operation of μ PD471X Series	18
5.2 Basic Operation of μ PD472X Series.....	18
6. INTERNAL BLOCK DIAGRAMS.....	19
6.1 μ PD471X Series	19
6.1.1 DC/DC converter block	19
6.1.2 Driver output logic	20
6.1.3 Receiver output logic.....	20
6.1.4 Receiver input threshold voltage.....	20
6.1.5 Input pin treatment.....	21
6.2 μ PD472X Series	22
6.2.1 DC/DC Converter Block	22
6.2.2 Driver output logic	23
6.2.3 Receiver output logic.....	23
6.2.4 Switching voltage boosting mode.....	23
6.2.5 Input pin treatment.....	24
7. NOTES FOR USE.....	25
8. TYPICAL CHARACTERISTICS	26
9. RS-232 STANDARD.....	32
9.1 What is the RS-232 Standard?	32
9.2 Signal Level	32
9.3 Basics of RS-232C Communication	33
10. TYPICAL APPLICATION	34
11. REVISION HISTORY OF PRODUCTS.....	35

12. Q&A	36
12.1 Internal Circuit Functions.....	36
12.2 Characteristics of Boosting Circuit.....	37
12.3 External Capacitors	38
12.4 Transfer Rate	39
12.5 Reliability	42
12.6 Equivalent Products of Other Companies.....	43
12.7 Marking, Packages and Others.....	44
APPENDIX ELECTRICAL SPECIFICATIONS (TYPICAL).....	46
Appendix 1. μPD471X Series.....	46
Appendix 2. μPD472X Series.....	48

1. INTRODUCTION

The serial communication standard EIA/TIA-232-E (generally called "RS-232"), established by EIA and TIA, has been used for industrial devices. However, today it is widely used as a communication means between office automation equipment that equips serial interface, and PCs and PC peripheral devices or home appliances.

NEC lines up six μ PD471X Series products and five μ PD472X Series products so that they can be widely applied to various devices for industrial equipment and appliances as ICs for RS-232 line driver/receivers.

This document summarizes usage of the products, technical data, and notes for using these ICs.

Your necessary information is found as follows:

- For overview of RS-232 standard: → Refer to Chapter **9. RS-232 STANDARD.**
- For overview and list of NEC's products: → Refer to Chapter **2. FEATURES OF ICS FOR RS-232 LINE DRIVER/RECEIVERS** and Chapter **3. SERIES LINEUP.**
- For details on functions of NEC's products: → Refer to Chapter **6. INTERNAL BLOCK DIAGRAMS.**
- For characteristics and performance of NEC's products: → Refer to Chapter **8. TYPICAL CHARACTERISTICS.**
- For answers to common questions and how-to: → Refer to Chapter **12. Q&A.**

2. FEATURES OF ICS FOR RS-232 LINE DRIVER/RECEIVERS

There are two types of product series of ICs for RS-232 Line Driver/Receiver, and each type has following features:

○ μ PD471X Series

- Compliant with EIA/TIA-232-E standard.
- Operated by single power supply with voltage of +5 V
- Positive and negative outputs by four external capacitors and on-chip DC/DC converter
- On-chip driver output control functions
- Function for selecting receiver input threshold voltage
- Low current dissipation mode by standby function
- Two types of packages: DIP and SOP

○ μ PD472X Series

- Complied with EIA/TIA-232-E Standard
- Operated by single power supply with either voltage of +5 V or +3.3 V
- Positive and negative outputs by four or five external capacitors and on-chip DC/DC converter
- Low current dissipation mode by standby function
- On-chip receiver functions which can be operated during standby
- SSOP package for space saving

3. SERIES LINEUP

3.1 Selection Guide

The list of ICs for RS-232 line driver/receivers is shown below.

Part Number	Driver	Receiver	Power Supply Voltage	Standby	Driver Output Control	Low Current Dissipation Receiver Operation Mode
μPD4711B	2	2	5 V	○	○	×
μPD4712C	4	4	5 V	○	○	×
μPD4712D	4	4	5 V	○	○	×
μPD4713A	3	3	5 V	○	○	×
μPD4714A	3	5	5 V	○	○	×
μPD4715A	5	3	5 V	○	○	×
μPD4721	2	2	3.3/5 V	○	×	×
μPD4722	4	4	3.3/5 V	○	×	○
μPD4723	3	3	3.3/5 V	○	×	○
μPD4724	3	5	3.3/5 V	○	×	○
μPD4726	4	7	5 V	○	×	○

○: Available ×: Not available

3.2 Ordering Information

Ordering information and the package list of ICs for RS-232 line driver/receivers are shown below.

Part Number	Ordering Information	Package
μPD4711B	μPD4711BCX	20-pin DIP (300 mil)
	μPD4711BGS	20-pin SOP (300 mil)
μPD4712C	μPD4712CCY	28-pin DIP (400 mil)
	μPD4712CGT	28-pin SOP (375 mil)
μPD4712D	μPD4712DCY	28-pin DIP (400 mil)
	μPD4712DGT	28-pin SOP (375 mil)
μPD4713A	μPD4713ACX	24-pin DIP (300 mil)
	μPD4713AGT	24-pin SOP (375 mil)
μPD4714A	μPD4714ACY	28-pin DIP (400 mil)
	μPD4714AGT	28-pin SOP (375 mil)
μPD4715A	μPD4715ACY	28-pin DIP (400 mil)
	μPD4715AGT	28-pin SOP (375 mil)
μPD4721	μPD4721GS-GJG	20-pin SSOP (300 mil)
μPD4722	μPD4722GS-GJG	30-pin SSOP (300 mil)
μPD4723	μPD4723GS-GJG	30-pin SSOP (300 mil)
μPD4724	μPD4724GS-GJG	30-pin SSOP (300 mil)
μPD4726	μPD4726GS-BAF	36-pin SSOP (300 mil)

4. PACKAGE DRAWINGS, PIN CONFIGURATIONS, AND FUNCTIONAL BLOCK DIAGRAMS

4.1 Package Drawings

20PIN PLASTIC DIP (300 mil)

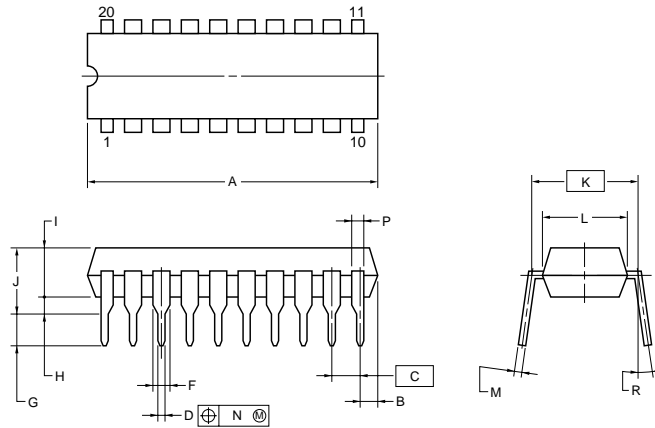

NOTES

- 1) Each lead centerline is located within 0.25 mm (0.01 inch) of its true position (T.P.) at maximum material condition.
- 2) Item "K" to center of leads when formed parallel.

ITEM	MILLIMETERS	INCHES
A	25.40 MAX.	1.000 MAX.
B	1.27 MAX.	0.050 MAX.
C	2.54 (T.P.)	0.100 (T.P.)
D	0.50±0.10	0.020 ^{+0.004} _{-0.005}
F	1.1 MIN.	0.043 MIN.
G	3.5±0.3	0.138±0.012
H	0.51 MIN.	0.020 MIN.
I	4.31 MAX.	0.170 MAX.
J	5.08 MAX.	0.200 MAX.
K	7.62 (T.P.)	0.300 (T.P.)
L	6.4	0.252
M	0.25 ^{+0.10} _{-0.05}	0.010 ^{+0.004} _{-0.003}
N	0.25	0.01
P	0.9 MIN.	0.035 MIN.
R	0-15°	0-15°

P20C-100-300A,C-1

24PIN PLASTIC DIP (300 mil)

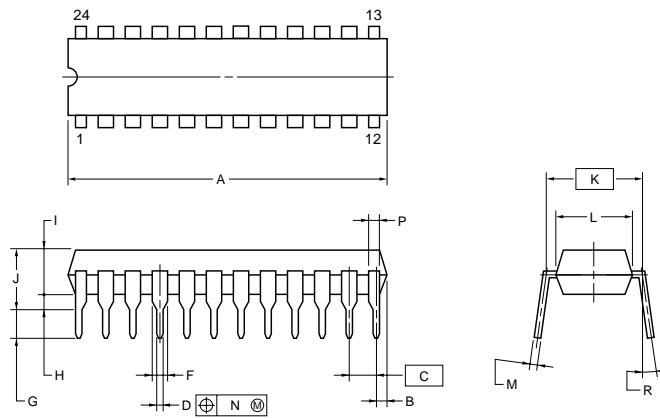

NOTES

- 1) Each lead centerline is located within 0.25 mm (0.01 inch) of its true position (T.P.) at maximum material condition.
- 2) Item "K" to center of leads when formed parallel.

ITEM	MILLIMETERS	INCHES
A	33.02 MAX.	1.300 MAX.
B	2.54 MAX.	0.100 MAX.
C	2.54 (T.P.)	0.100 (T.P.)
D	0.50±0.10	0.020 ^{+0.004} _{-0.005}
F	1.2 MIN.	0.047 MIN.
G	3.5±0.3	0.138±0.012
H	0.51 MIN.	0.020 MIN.
I	4.31 MAX.	0.170 MAX.
J	5.08 MAX.	0.200 MAX.
K	7.62 (T.P.)	0.300 (T.P.)
L	6.4	0.252
M	0.25 ^{+0.10} _{-0.05}	0.010 ^{+0.004} _{-0.003}
N	0.25	0.01
P	1.0 MIN.	0.039 MIN.
R	0-15°	0-15°

P24C-100-300A-1

28PIN PLASTIC DIP (400 mil)

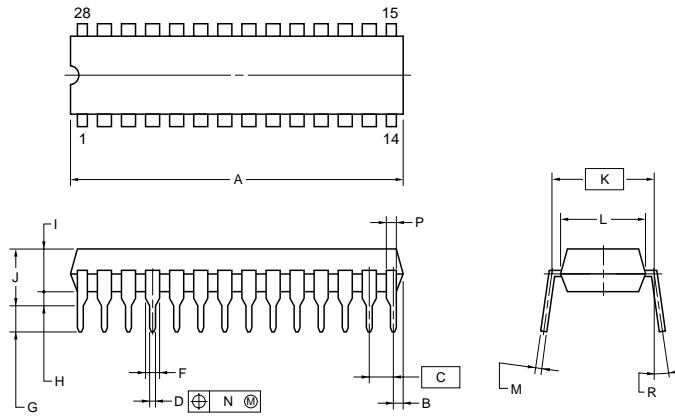

NOTES

- Each lead centerline is located within 0.25 mm (0.01 inch) of its true position (T.P.) at maximum material condition.
- Item "K" to center of leads when formed parallel.

ITEM	MILLIMETERS	INCHES
A	35.56 MAX.	1.400 MAX.
B	1.27 MAX.	0.050 MAX.
C	2.54 (T.P.)	0.100 (T.P.)
D	0.50±0.10	0.020 ^{+0.004} _{-0.005}
F	1.1 MIN.	0.043 MIN.
G	3.5±0.3	0.138±0.012
H	0.51 MIN.	0.020 MIN.
I	4.31 MAX.	0.170 MAX.
J	5.72 MAX.	0.226 MAX.
K	10.16 (T.P.)	0.400 (T.P.)
L	8.6	0.339
M	0.25 ^{+0.10} _{-0.05}	0.010 ^{+0.004} _{-0.003}
N	0.25	0.01
P	0.9 MIN.	0.035 MIN.
R	0-15°	0-15°

P28C-100-400-1

20 PIN PLASTIC SOP (300 mil)

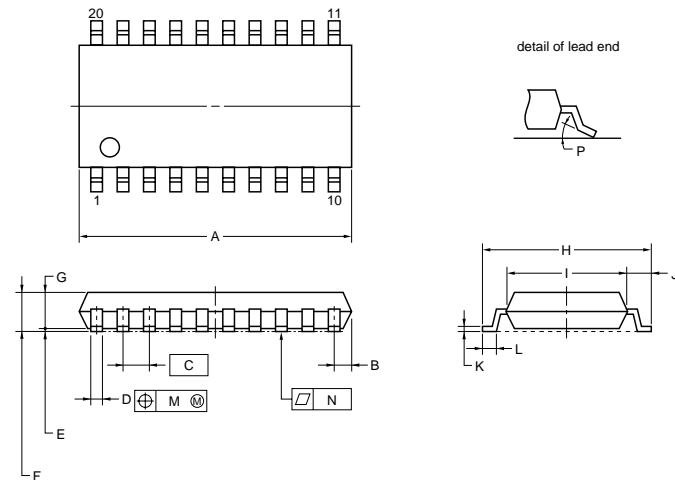

detail of lead end



NOTE

- Each lead centerline is located within 0.12 mm (0.005 inch) of its true position (T.P.) at maximum material condition.

ITEM	MILLIMETERS	INCHES
A	12.7±0.3	0.500±0.012
B	0.78 MAX.	0.031 MAX.
C	1.27 (T.P.)	0.050 (T.P.)
D	0.42 ^{+0.08} _{-0.07}	0.017 ^{+0.003} _{-0.004}
E	0.1±0.1	0.004±0.004
F	1.8 MAX.	0.071 MAX.
G	1.55±0.05	0.061±0.002
H	7.7±0.3	0.303±0.012
I	5.6±0.2	0.220 ^{+0.009} _{-0.008}
J	1.1	0.043
K	0.22 ^{+0.08} _{-0.07}	0.009 ^{+0.003} _{-0.004}
L	0.6±0.2	0.024 ^{+0.008} _{-0.009}
M	0.12	0.005
N	0.10	0.004
P	3 ^{+7°} _{-3°}	3 ^{+7°} _{-3°}

P20GM-50-300B, C-5

24 PIN PLASTIC SOP (375 mil)

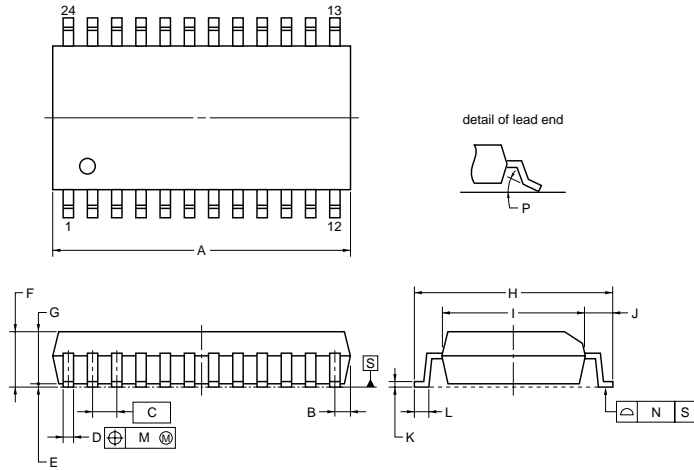

NOTES

- Controlling dimension — millimeter.
- Each lead centerline is located within 0.12 mm (0.005 inch) of its true position (T.P.) at maximum material condition.

ITEM	MILLIMETERS	INCHES
A	15.4±0.14	0.606±0.006
B	0.78 MAX.	0.031 MAX.
C	1.27 (T.P.)	0.050 (T.P.)
D	0.42 ^{-0.08} / _{0.07}	0.017 ^{+0.003} / _{-0.004}
E	0.125±0.075	0.005 ^{+0.003} / _{-0.004}
F	2.77 MAX.	0.110 MAX.
G	2.47±0.1	0.097 ^{+0.005} / _{-0.004}
H	10.3±0.3	0.406 ^{+0.012} / _{-0.013}
I	7.2	0.283
J	1.6	0.063
K	0.17 ^{+0.08} / _{-0.07}	0.007 ^{+0.003} / _{-0.004}
L	0.8±0.2	0.031 ^{+0.009} / _{-0.008}
M	0.12	0.005
N	0.15	0.006
P	3 ^{+7°} / _{-3°}	3 ^{+7°} / _{-3°}

P24GM-50-375B-4

28-PIN PLASTIC SOP (375 mil)

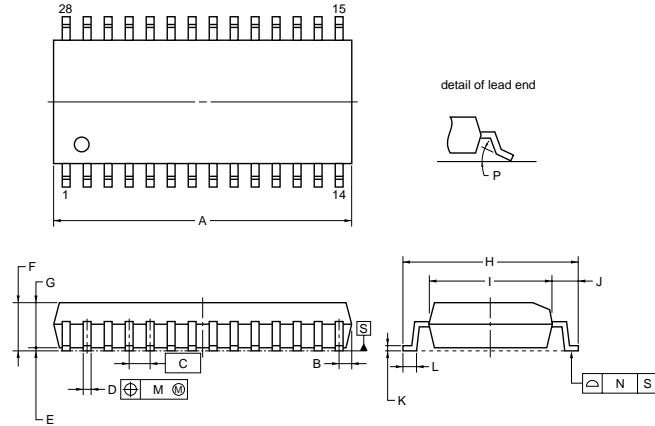

NOTE

Each lead centerline is located within 0.12 mm of its true position (T.P.) at maximum material condition.

ITEM	MILLIMETERS
A	17.9±0.17
B	0.78 MAX.
C	1.27 (T.P.)
D	0.42 ^{-0.08} / _{-0.07}
E	0.1±0.1
F	2.6±0.2
G	2.50
H	10.3±0.3
I	7.2±0.2
J	1.6±0.2
K	0.17 ^{+0.08} / _{-0.07}
L	0.8±0.2
M	0.12
N	0.15
P	3 ^{+7°} / _{-3°}

P28GM-50-375B-4

20 PIN PLASTIC SHRINK SOP (300 mil)

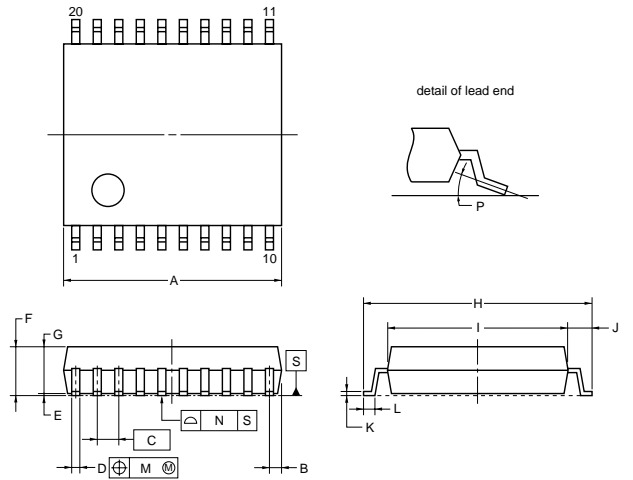

- NOTE**
1. Controlling dimension — millimeter.
 2. Each lead centerline is located within 0.12 mm (0.005 inch) of its true position (T.P.) at maximum material condition.

ITEM	MILLIMETERS	INCHES
A	6.7±0.3	0.264 ^{+0.012} _{-0.013}
B	0.575 MAX.	0.023 MAX.
C	0.65 (T.P.)	0.026 (T.P.)
D	0.32 ^{+0.08} _{-0.07}	0.013 ^{+0.003} _{-0.004}
E	0.125±0.075	0.005±0.003
F	2.0 MAX.	0.079 MAX.
G	1.7±0.1	0.067 ^{+0.004} _{-0.005}
H	8.1±0.3	0.319±0.012
I	6.1±0.2	0.240±0.008
J	1.0±0.2	0.039 ^{+0.009} _{-0.008}
K	0.15 ^{+0.10} _{-0.05}	0.006 ^{+0.004} _{-0.002}
L	0.5±0.2	0.020 ^{+0.008} _{-0.009}
M	0.12	0.005
N	0.10	0.004
P	3 ^{+7°} _{-3°}	3 ^{+7°} _{-3°}

P20GM-65-300B-3

30 PIN PLASTIC SHRINK SOP (300 mil)

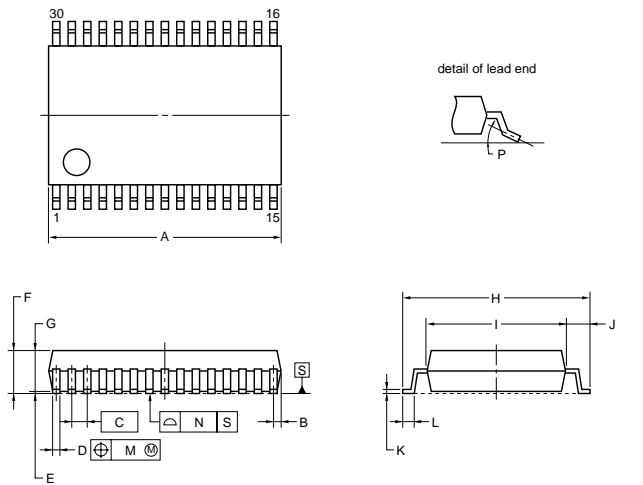

- NOTES**
1. Controlling dimension — millimeter.
 2. Each lead centerline is located within 0.10 mm (0.004 inch) of its true position (T.P.) at maximum material condition.

ITEM	MILLIMETERS	INCHES
A	9.85±0.26	0.388±0.011
B	0.51 MAX.	0.020 MAX.
C	0.65 (T.P.)	0.026 (T.P.)
D	0.32 ^{+0.08} _{-0.07}	0.013 ^{+0.003} _{-0.004}
E	0.125±0.075	0.005±0.003
F	2.0 MAX.	0.079 MAX.
G	1.7±0.1	0.067±0.004
H	8.1±0.2	0.319±0.008
I	6.1±0.2	0.240±0.008
J	1.0±0.2	0.039 ^{+0.009} _{-0.008}
K	0.17 ^{+0.09} _{-0.07}	0.007 ^{+0.003} _{-0.004}
L	0.5±0.2	0.020 ^{+0.008} _{-0.009}
M	0.10	0.004
N	0.10	0.004
P	3 ^{+7°} _{-3°}	3 ^{+7°} _{-3°}

P30GS-65-300B-2

36 PIN PLASTIC SSOP (300 mil)

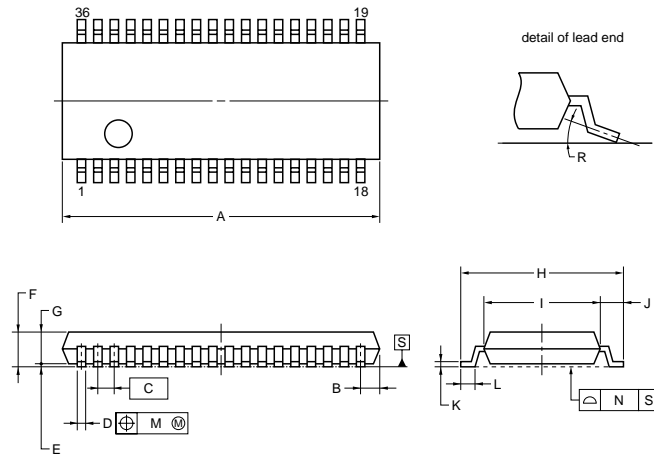

NOTE
 Each lead centerline is located within 0.10 mm of its true position (T.P.) at maximum material condition.

ITEM	MILLIMETERS
A	15.3±0.24
B	0.97 MAX.
C	0.8 (T.P.)
D	0.37 ^{+0.08} _{-0.07}
E	0.125±0.075
F	1.675 ^{+0.125} _{-0.175}
G	1.55
H	7.7±0.3
I	5.6±0.15
J	1.05±0.2
K	0.22 ^{+0.08} _{-0.07}
L	0.6±0.2
M	0.10
N	0.10
R	5°±5°

P36GM-80-300B-4

4.2 Pin Configurations

μ PD4711B

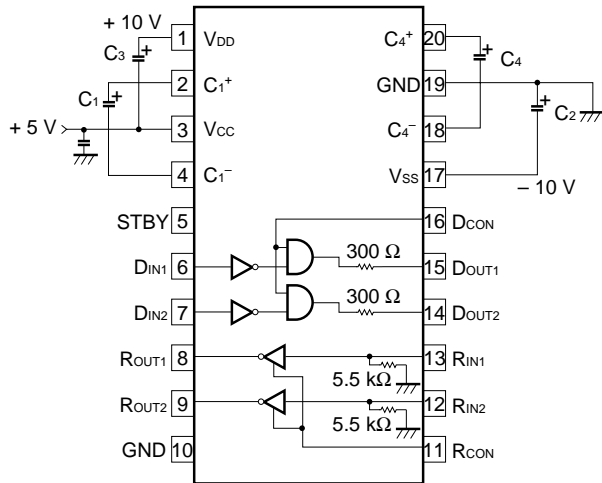

μ PD4712C/D

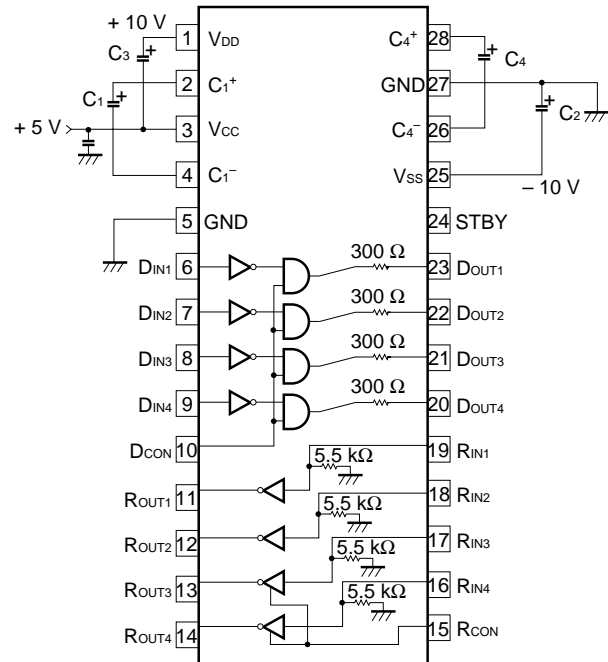

μ PD4713A

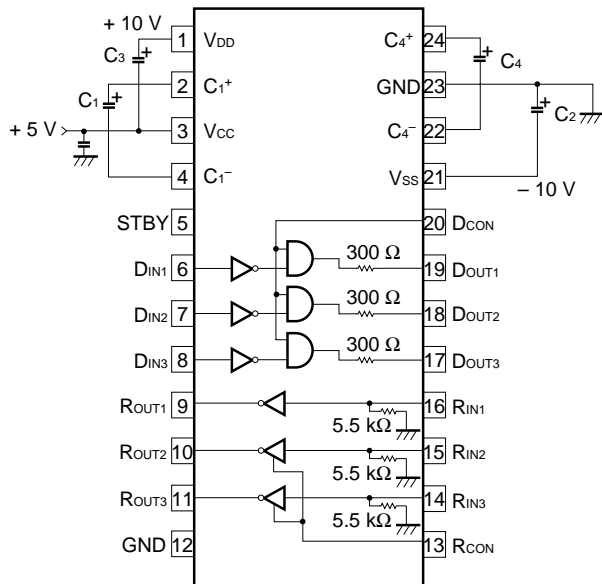

μ PD4714A

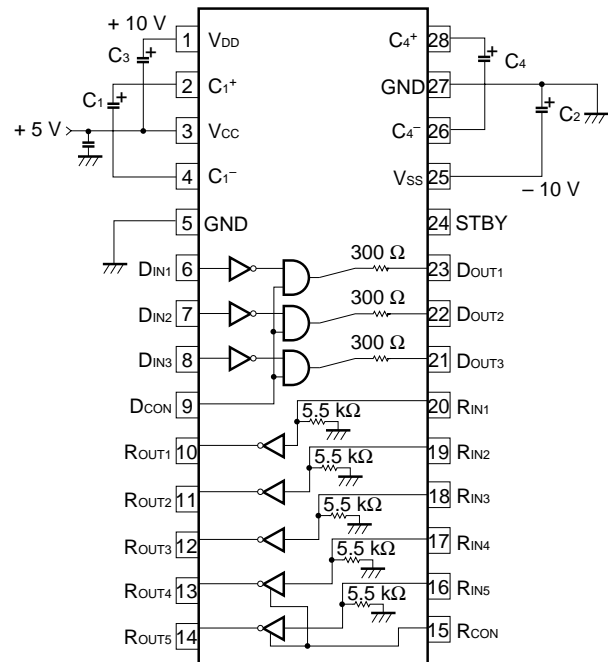

μPD4715A

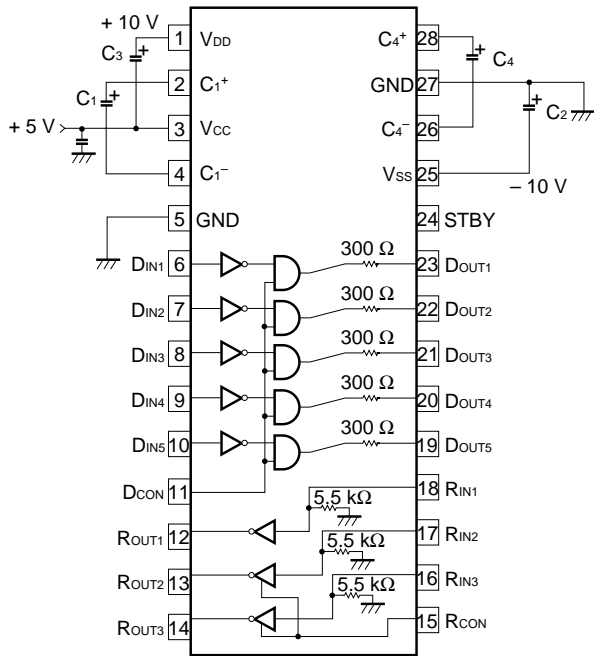

μPD4721

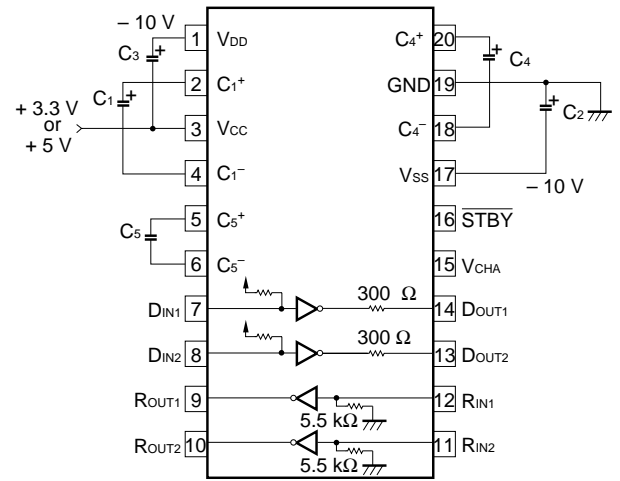

μPD4722

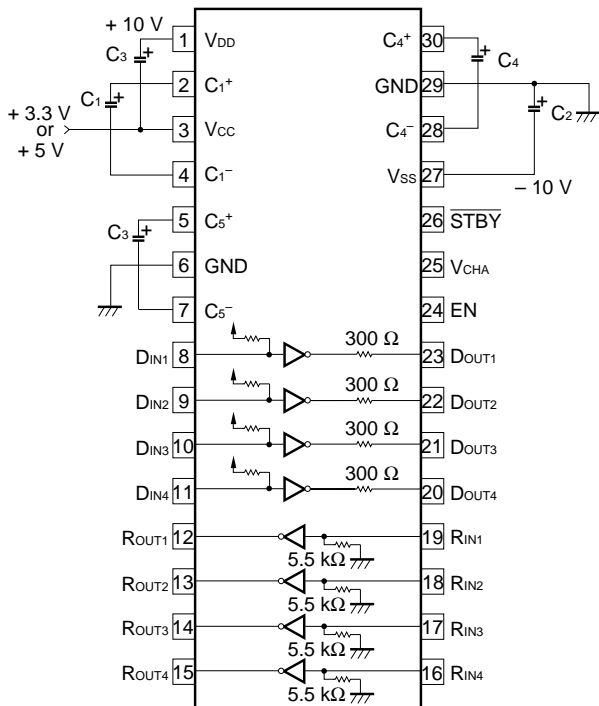

μPD4723

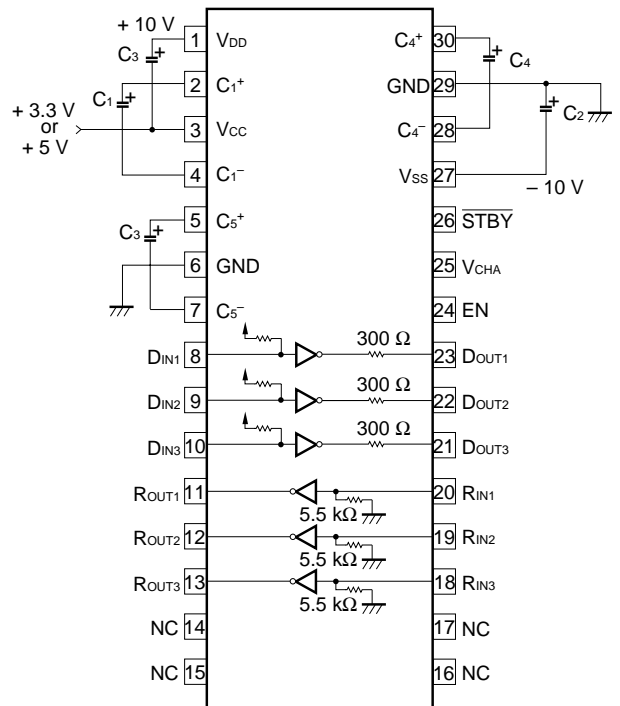

μPD4724

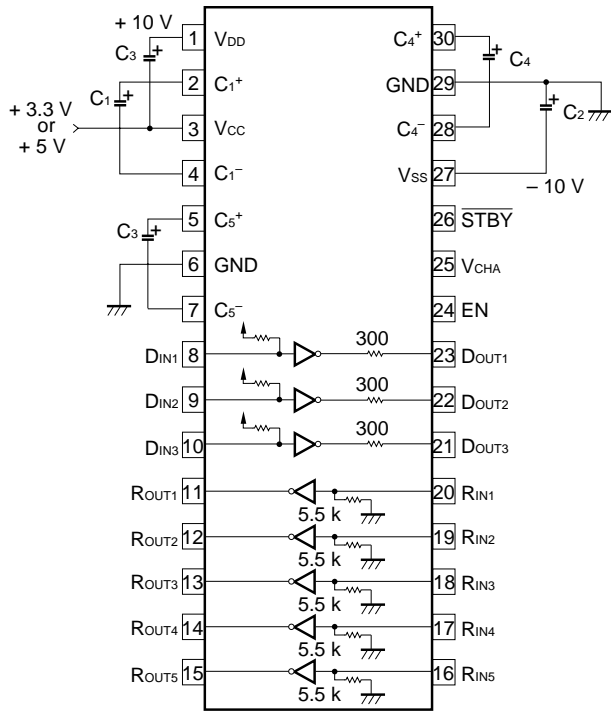

μPD4726

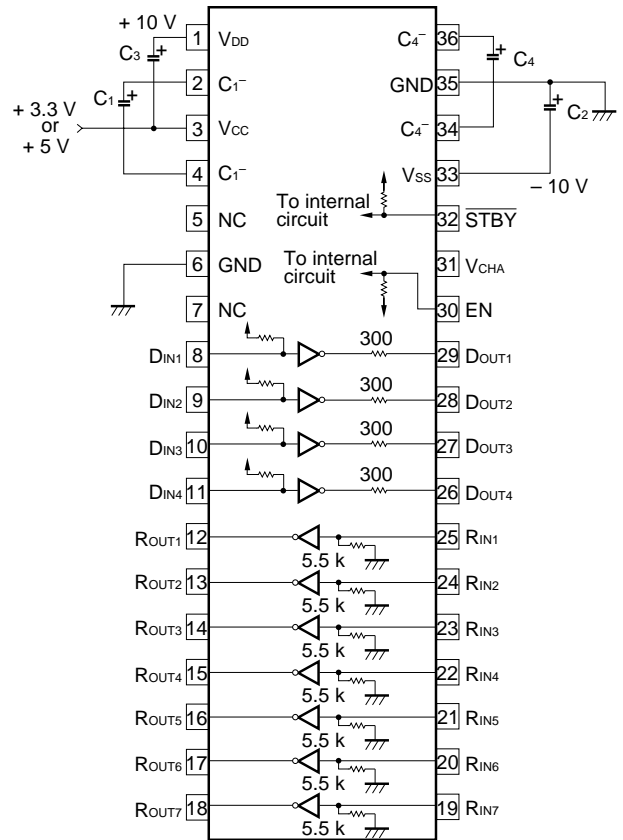

4.3 Functional Block Diagrams

μPD471X Series

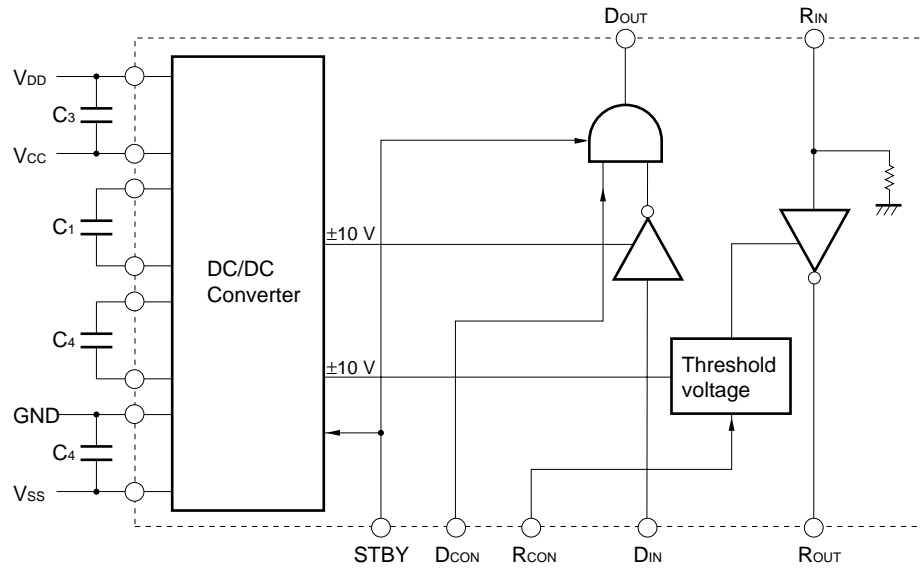

μPD472X Series

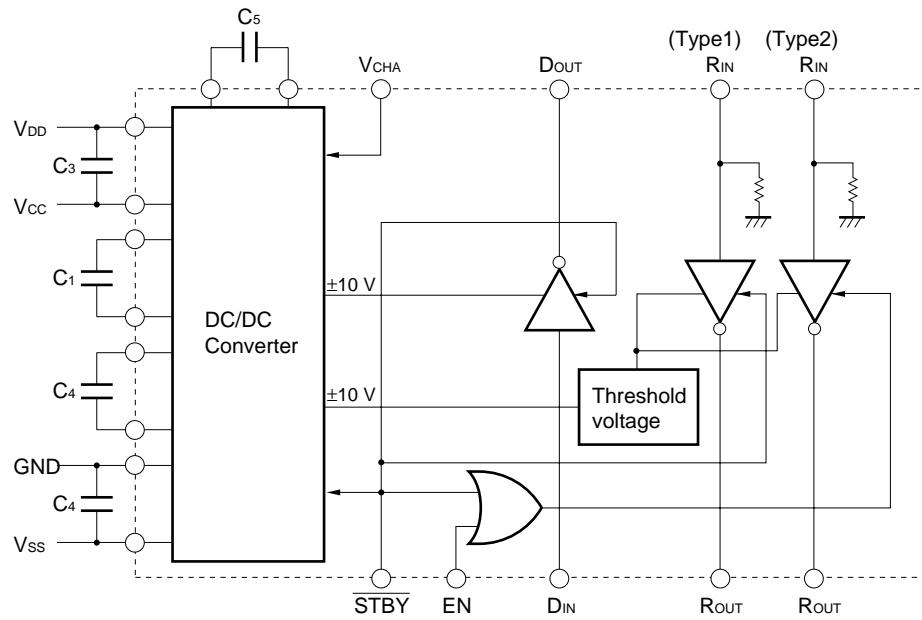

5. BASIC OPERATIONS

5.1 Basic Operation of μ PD471X Series

The basic operation of the μ PD471X Series is shown in the figure below.

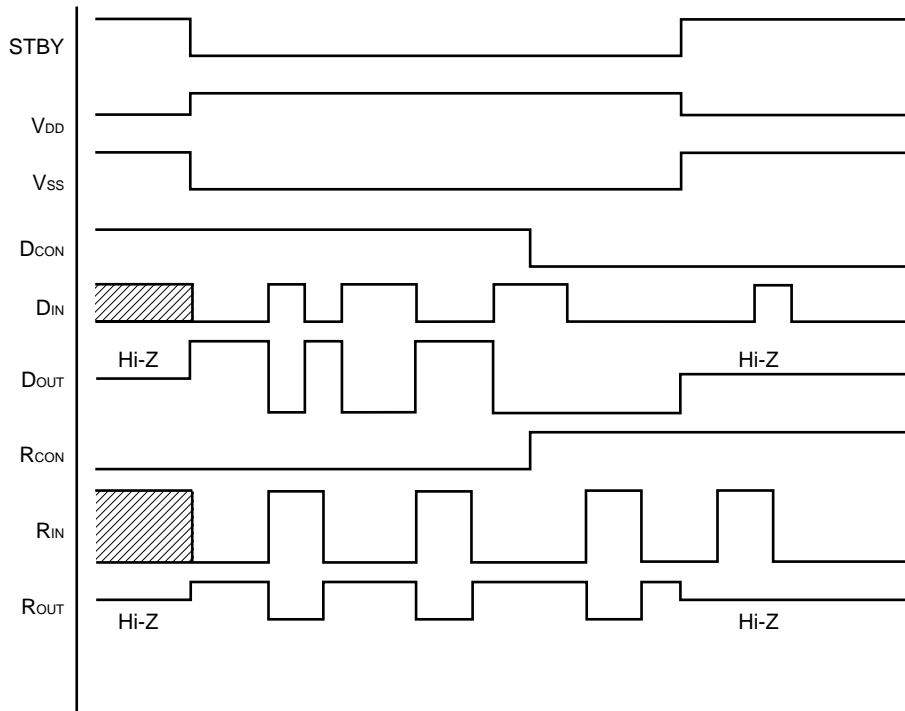

5.2 Basic Operation of μ PD472X Series

The basic operation of the μ PD472X Series is shown in the figure below.

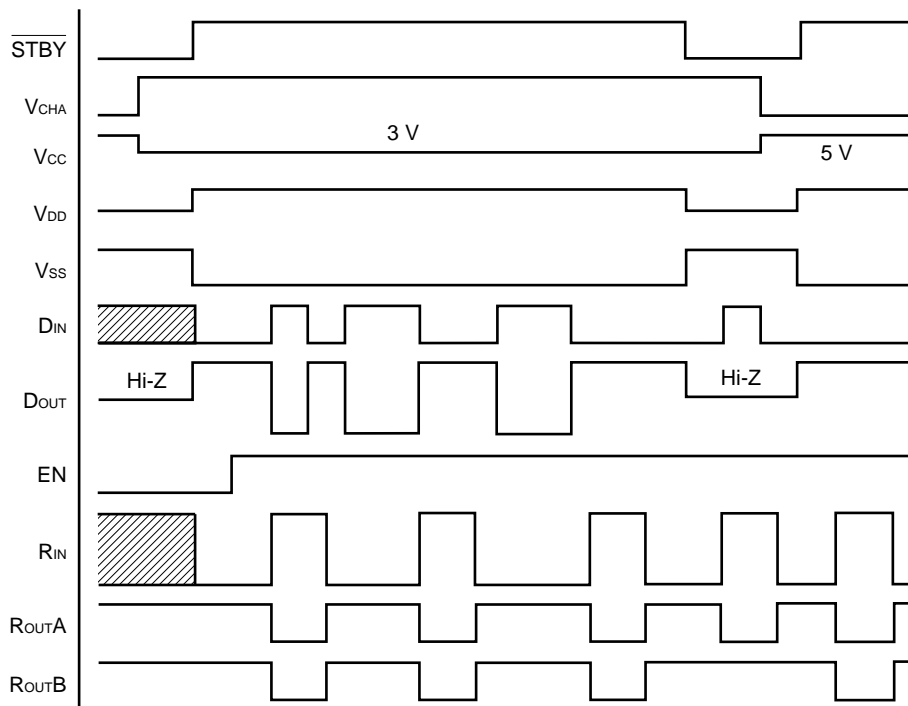

6. INTERNAL BLOCK DIAGRAM

6.1 μ PD471X Series

6.1.1 DC/DC converter block

The μ PD471X Series incorporate a DC/DC converter block. A DC/DC converter is a circuit to boost V_{CC} to V_{DD}/V_{SS} to generate the necessary voltage level for RS-232 communication by fast switching with external capacitors.

RS-232 communication, which requires positive and negative power supplies even with a single voltage of 5 V, can be achieved by integrating this circuit with a RS-232 line driver/receiver.

The maximum voltage of electric potential difference applied at the both ends of each capacitor having characteristics of DC/DC converter circuit is shown in the table below, and the theoretical operating waveform of each pin is shown in the figure below.

Also, DC/DC converter circuit is stopped when STBY is at H. At this moment, $V_{DD} = V_{CC}$ and $V_{SS} = GND$.

The electric potential difference applied to each capacitor when $V_{CC} = 5$ V

Capacitor	Voltage (V)
$C_1^+ - C_1^-$	5
$C_2^+ - C_2^-$	10
$C_3^+ - C_3^-$	5
$C_4^+ - C_4^-$	5

Operating waveform at capacitors

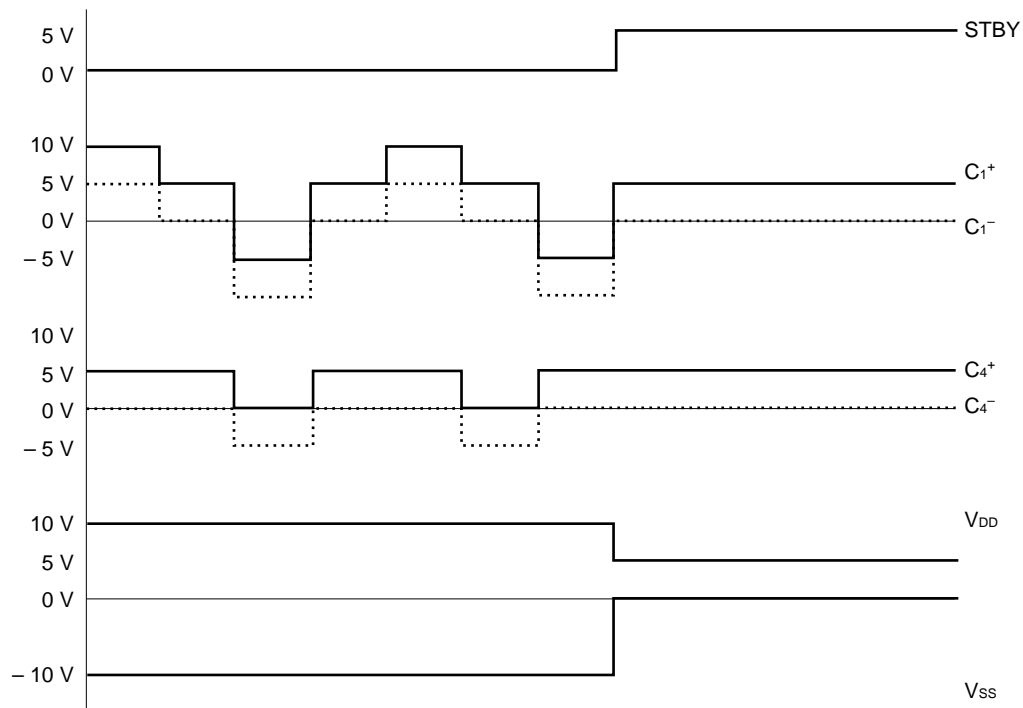

6.1.2 Driver output logic

STBY is the Standby Control Signal.

When STBY is at H, D_{OUT} becomes high impedance regardless of the status of D_{CON} and D_{IN}. While STBY is at L, driver output depends on input signals from D_{CON} and D_{IN}.

D_{CON} is driver output control signal and active at high.

When D_{CON} is H, D_{IN} (TTL level) is reversed and output from D_{OUT} (RS-232 level). While D_{CON} is L, D_{OUT} is fixed at L regardless of the status of D_{IN}.

Truth table of driver output logic is shown below (refer to **12.1 Internal Circuit Functions** in **12. Q&A LIST** for actual usage of D_{CON}).

STBY	D _{CON}	D _{IN}	D _{OUT}	Remarks
H	X	X	Hi-Z	Standby mode (DC/DC Converter stopped)
L	L	X	L	Mark level output
L	H	L	H	Space level output
L	H	H	L	Mark level output

6.1.3 Receiver output logic

When STBY is at H, R_{OUT} becomes High Impedance state regardless of the status of R_{IN}. While STBY is at L, R_{IN} (RS-232 level) is reversed and output from R_{OUT} (TTL level).

Truth table of receiver output logic is shown below.

STBY	R _{IN}	R _{OUT}	Remarks
H	X	Hi-Z	Standby Mode (DC/DC converter stopped)
L	L	H	Mark level output
L	H	L	Space level output

6.1.4 Receiver input threshold voltage

The μ PD471X Series has a function to switch receiver input threshold voltage as its specific function. Refer to individual data sheet for characteristics of threshold voltage.

When R_{CON} is at L, R_{OUT} always operates in A Mode. When R_{CON} is at H, R_{IN}A operates in A Mode and R_{IN}B operates in B Mode as the table below.

The truth table and pin list of each part number are shown below (refer to **12.1 Internal Circuit Functions** in **12. Q&A** for actual usage of R_{CON})

The truth table of receiver input threshold

R _{CON}	R _{IN} A	R _{IN} B
L	A Mode	A Mode
H	A Mode	B Mode (C Mode only in μ PD4712D)

The pin list of each product in A Mode and B Mode

Part Number	R _{INA}	R _{INB}
μPD4711B	–	R _{IN1} , R _{IN2}
μPD4712C/4712D	R _{IN1} , R _{IN2}	R _{IN3} , R _{IN4}
μPD4713A	R _{IN1}	R _{IN2} , R _{IN3}
μPD4714A	R _{IN1} , R _{IN2} , R _{IN3}	R _{IN4} , R _{IN5}
μPD4715A	R _{IN1}	R _{IN2} , R _{IN3}

6.1.5 Input pin treatment

The internal configuration of input pins of the μPD471X Series is shown in the table below. If an input pin is opened, through current flows as CMOS-specific characteristics. Therefore, open pins should be treated as follows:

Pin Name	Pull-up or Pull-down Resistor	Handling of Open Pins
STBY	Pull-down resistor	Even if the input is open, the input becomes “L” and the operation-mode is active.
D _{CON}	None	Be sure to fix it at “H” or “L” level before using.
D _{IN}		
R _{CON}		
R _{IN}	Pull-down resistor (5.5 kΩ)	Even if the input is open, the input becomes “L” and the output becomes “H.”

6.2 μ PD472X Series

6.2.1 DC/DC Converter Block

The μ PD472X Series incorporates a DC/DC converter block. A DC/DC converter Block is a circuit to boost V_{CC} to V_{DD}/V_{SS} to generate the necessary voltage level for RS-232 communication by fast switching with external capacitors. It has a Double Boosting Mode and Triple Boosting Mode to use single power supply either voltage with 5 V or 3.3 V as specific function of μ PD472X Series.

RS-232 communication, which requires positive and negative power supplies even with a single voltage of 5 V or 3.3 V, can be achieved by integrating this circuit with an RS-232 line driver/receiver.

The maximum voltage of electric potential difference applied at both ends of each capacitor having characteristics of DC/DC converter circuit is shown in the table below, and theoretical operating waveform of each pin (Only in 3-V mode. The waveform in 5-V mode is the same as the one of the μ PD471X Series.) is shown in the figure below.

Also, DC/DC Converter circuit is stopped when \overline{STBY} is at L. At this moment, $V_{DD} = V_{CC}$ and $V_{SS} = GND$.

Electric potential difference applied to each capacitor when $V_{CC} = 5\text{ V}$ (5-V Mode) or 3 V (3-V Mode)

Capacitor	Voltage (V)	
	5-V Mode	3-V Mode
$C_1^+ - C_1^-$	5.0	3.0
$C_2^+ - C_2^-$	10.0	9.0
$C_3^+ - C_3^-$	5.0	6.0
$C_4^+ - C_4^-$	5.0	3.0
$C_5^+ - C_5^-$	5.0	3.0

Operating waveform at capacitors

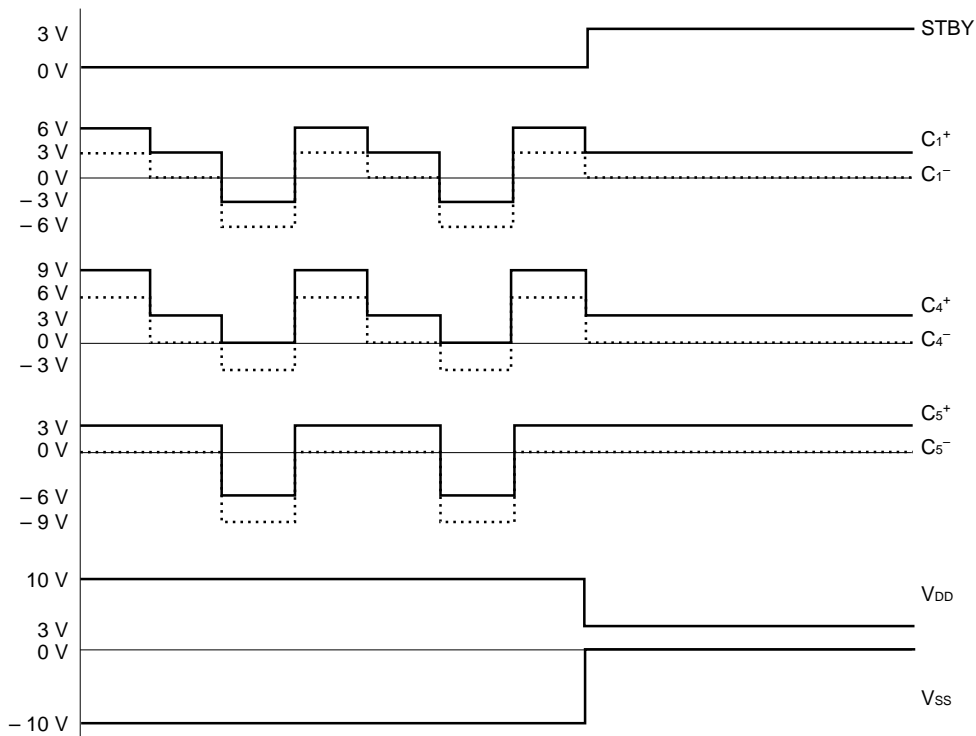

6.2.2 Driver output logic

When $\overline{\text{STBY}}$ is at L, D_{OUT} becomes high impedance regardless of the status of D_{CON} and D_{IN} .

When $\overline{\text{STBY}}$ is H, D_{IN} (TTL level) is reversed and output from D_{OUT} (RS-232 level).

The truth table of driver output logic is shown below.

$\overline{\text{STBY}}$	D_{IN}	D_{OUT}	Remarks
L	X	Hi-Z	Standby Mode (DC/DC converter stopped)
H	L	H	Space level output
H	H	L	Mark level output

6.2.3 Receiver output logic

When $\overline{\text{STBY}}$ is at L, two types of standby modes can be selected depending on the EN logic. When EN is L, regardless of the status of R_{IN} (RS-232 level), H is output for R_{OUT} (TTL level). When EN is H, R_{OUTA} (TTL level) is output by an inverter without hysteresis for the input of R_{INA} (RS-232 level). Regardless of R_{INB} (RS-232 level), H is output for R_{OUTB} (TTL level).

When $\overline{\text{STBY}}$ is H, R_{IN} (RS-232 level) is reversed and output from R_{OUT} (TTL level) regardless of the EN state.

The truth table of the receiver output logic is shown below (refer to **12.1 Internal Circuit Functions** in **12. Q&A** for actual sample usage of EN pin).

Truth table of receiver output logic

$\overline{\text{STBY}}$	EN	R_{IN}		R_{OUT}		Remarks
		R_{INA}	R_{INB}	R_{OUTA}	R_{OUTB}	
L	L	X	X	H	H	Standby Mode 1 (DC/DC converter stopped)
L	H	L	X	H	H	Standby Mode 2 (DC/DC converter stopped)
L	H	H	X	L	H	Standby Mode 2 (DC/DC converter stopped)
H	X	L		H		Mark level output
H	X	H		L		Space level output

Pin list of each product in A Mode and B Mode

Part Number	R_{INA}	R_{INB}
μPD4721	–	$\text{R}_{\text{IN1}}, \text{R}_{\text{IN2}}$
μPD4722	$\text{R}_{\text{IN3}}, \text{R}_{\text{IN4}}$	$\text{R}_{\text{IN1}}, \text{R}_{\text{IN2}}$
μPD4723	$\text{R}_{\text{IN2}}, \text{R}_{\text{IN3}}$	R_{IN1}
μPD4724	$\text{R}_{\text{IN4}}, \text{R}_{\text{IN5}}$	$\text{R}_{\text{IN1}}, \text{R}_{\text{IN2}}, \text{R}_{\text{IN3}}$
μPD4726	$\text{R}_{\text{IN6}}, \text{R}_{\text{IN7}}$	$\text{R}_{\text{IN1}}, \text{R}_{\text{IN2}}, \text{R}_{\text{IN3}}, \text{R}_{\text{IN4}}, \text{R}_{\text{IN5}}$

6.2.4 Switching voltage boosting mode

Voltage boosting mode of internal DC/DC converter can be switched by V_{CHA} . When the voltage of the power supply used is lowered (5 V \rightarrow 3 V), it can be switched even when the power is turned on.

When you switch the voltage boosting mode, the operation mode must be Standby Mode ($\overline{\text{STBY}} = \text{L}$).

V_{CHA}	Operating Mode
L	5-V Mode (double boost)
H	3-V Mode (triple boost)

6.2.5 Input pin treatment

The internal configuration of input pins of the μ PD472X Series is shown in the table below. If an input pin is left open, through current flows due to CMOS-specific characteristics. Therefore, open pins should be treated as follows.

Pin Name	Pull-up or Pull-down Resistor	Handling of Open Pin
$\overline{\text{STBY}}$	None	Fix to "H" or "L" level.
V_{CHA}		
EN		
D_{IN}	Active pull-up resistor (up to 300 k Ω)	Even if the input is open, the input becomes "H" and the output becomes "L."
R_{IN}	Pull-down resistor (5.5 k Ω)	Even if the input is open, the input becomes "L" and the output becomes "H."

A pull-up resistor is connected to the D_{IN} pin so that the input potential is fixed even it is opened. This pull-up resistor is an active resistor whose resistance becomes higher when the input potential is low and becomes lower when the input potential is high (refer to **8. TYPICAL CHARACTERISTICS**).

Therefore, when the input voltage is L, the current passed through the pull-up resistor is 25 μA MAX., and the power dissipation due to the input current is negligibly low.

Also, fix the D_{IN} pin open or to H to minimize the power dissipation in Standby ($\overline{\text{STBY}} = \text{L}$).

At this time, the input current is 1 μA or lower, and the power dissipation due to the input current through pull-up resistor is minimized.

7. NOTES FOR USE

The following items are general notes for using ICs for RS-232 line driver/receivers. They are common between the μ PD471X Series and the μ PD472X Series unless otherwise specified.

Power block

- If V_{CC} is unstable, the on-chip DC/DC converter circuit may not properly operate. Therefore, it is recommended to connect a bypass capacitor (approximately 0.1 to 1 μ F) between V_{CC} and GND.
- Since V_{DD} and V_{SS} are output pins and their voltages are boosted up by the internal DC/DC converter circuit, do not feed or take out current to/from these pins (such as connecting any load). If any load is connected to these pins, the on-chip DC/DC converter circuit may not properly operate (refer to **12.2 Characteristics of Voltage Boosting Circuit** in **12. Q&A** for typical characteristics).

Pin treatment

- Fix all pins for control input (such as D_{CON} , R_{CON} , and $STBY$ pins) to High or Low, if no pull-down resistor is connected to them.
- If a driver input pin is open, through current may flow. Fix all unconnected driver input pins to High or Low (for μ PD471X Series).
- Ensure that voltage over rated voltage such as surge is not impressed to receiver input pins. If there is a possibility that the voltage higher than rated voltage is applied, it is recommended to connect an external protection circuit (refer to **12.5 Reliability** in **12. Q&A** for a typical application).

Selection of external capacitors

- Tantalum, aluminum electrolytic, and ceramic capacitors can be used for external capacitors for on-chip DC/DC converters. Since they are repeatedly charged and discharged by internal switching, use capacitors with better frequency characteristics.
- It is recommended to apply capacitors with a capacitance range of 4.7 to 47 μ F (for the μ PD471X Series, excepting the μ PD4711B with capacitance range of 1 to 47 μ F) and 0.33 to 4.7 μ F (for the μ PD472X Series, excepting μ PD4722 with capacitance range of 0.47 to 4.7 μ F). Determine appropriate capacitance within these ranges after evaluating with the actual product circuit. Note that the capacitance of electrolytic capacitors is lowered in low temperatures. Therefore, determine the capacitance of such capacitors with some margin taking into account the operating temperature.
- If only 5-V Mode ($V_{CHA} = "L"$ and $V_{CC} = 5$ V) is used, it is not necessary to connect the C_5 capacitor. In this case, the C_5 pin should be left open (for μ PD472X Series).

8. TYPICAL CHARACTERISTICS

The main characteristics of the μ PD4722 as a representative product for RS-232 line driver/receivers are shown below.

- Driver Input Characteristics

The characteristics of a pull-up resistor (active resistor) at a driver input pin are shown below.

- (1) In 5-V Mode operation
- (2) In 3.3-V Mode operation

- Characteristics of Driver Output slew rate vs. load capacitance

The slew rate characteristics when a load capacitance is connected to driver output 1 are shown below.

Conditions: $V_{CC} = 5\text{ V}$ and 3.3 V

External capacitor = $1.0\ \mu\text{F}$ (Tantalum)

$R_L = 3\ \text{k}\Omega$ (only at one output)

Note that the slew rate characteristics are lower than the curve shown here if simultaneous switching for all outputs is performed.

- Characteristics of driver output voltage vs. output current

The output characteristics with current at driver output are shown below.

Conditions: $V_{CC} = 4.5\text{ to }5.5\text{ V}$ and $3.0\text{ to }3.6\text{ V}$

External capacitor = $0.47\ \mu\text{F}$

With all driver outputs

- (1) Ceramic capacitors are used.
- (2) Tantalum capacitors are used.
- (3) Aluminum electrolytic capacitors are used.

- Characteristics of driver output voltage vs. external capacitors

The driver output characteristics when the capacitance of external capacitor is changed are shown below.

Conditions: $V_{CC} = 4.5\text{ V}$ and 3.0 V

Load $3\ \text{k}\Omega$

With all driver outputs

- Driver input characteristics

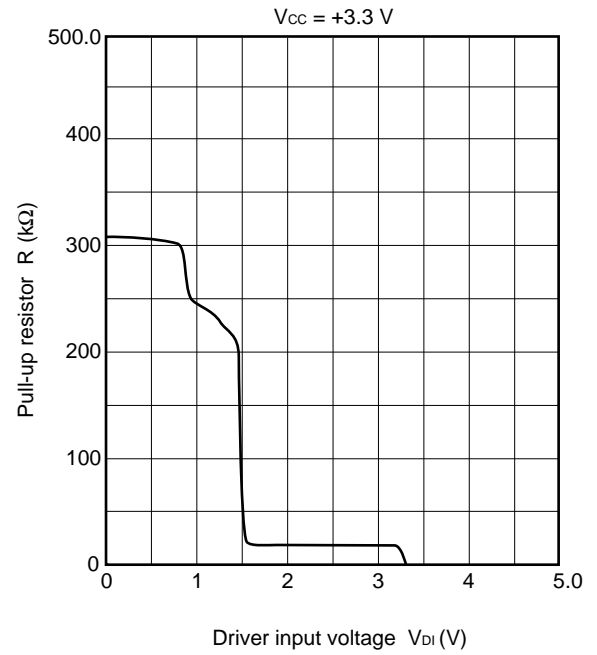
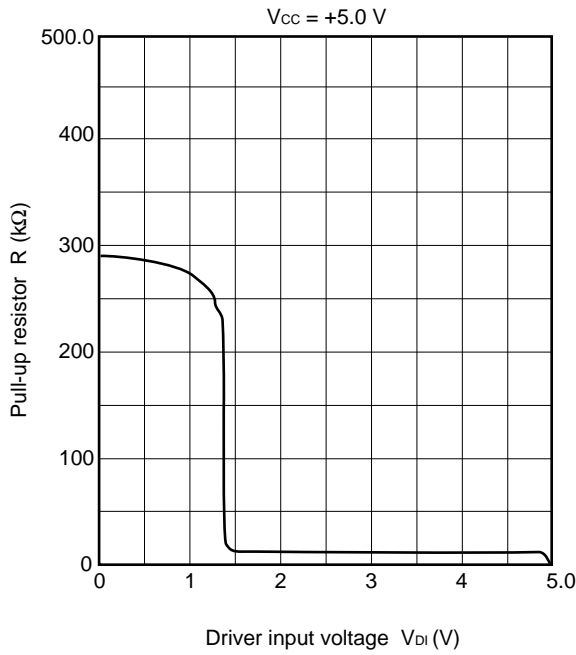

- Characteristics of driver output slew rate vs. load capacitance

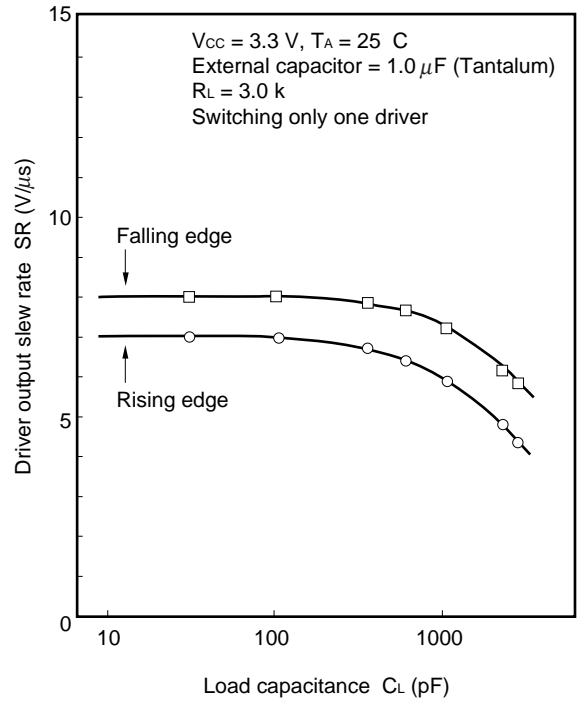
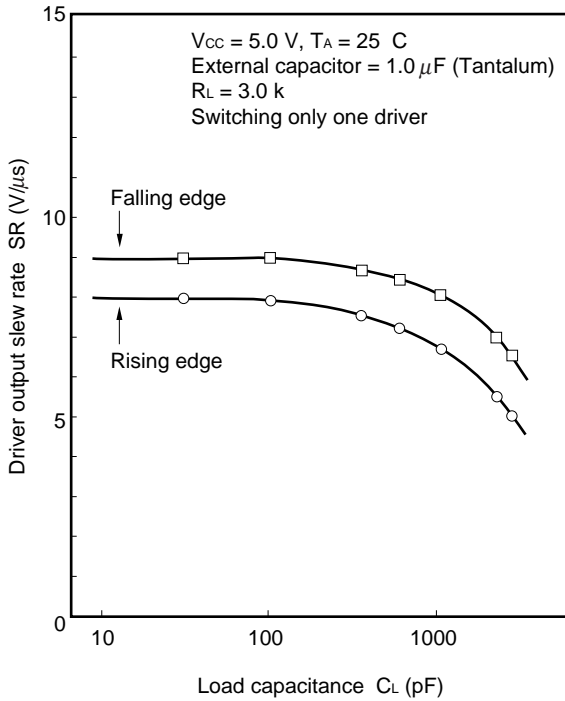

- Characteristics of driver output voltage vs. output current

(Ceramic capacitors used)

C_1 to $C_5 = 0.47 \mu\text{F}$: RPE123R474K50 manufactured by Murata Manufacturing Co., Ltd.

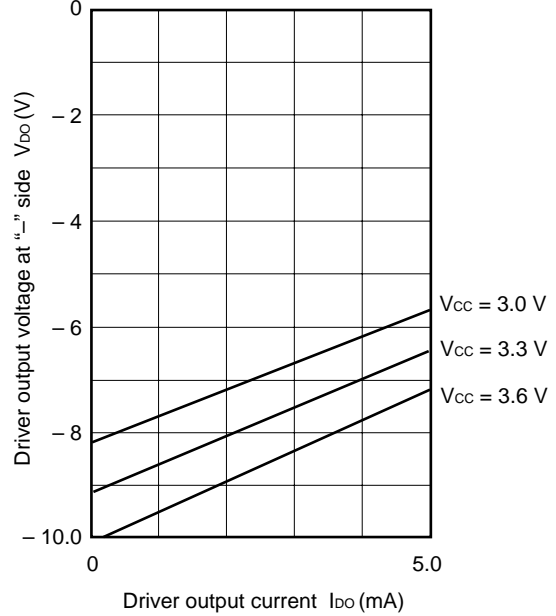
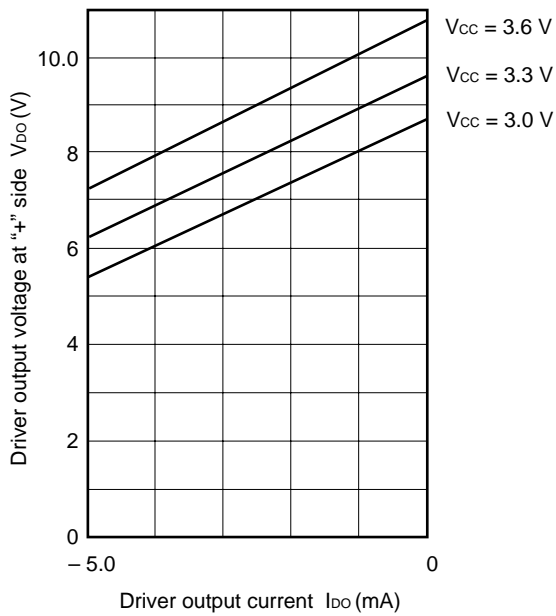
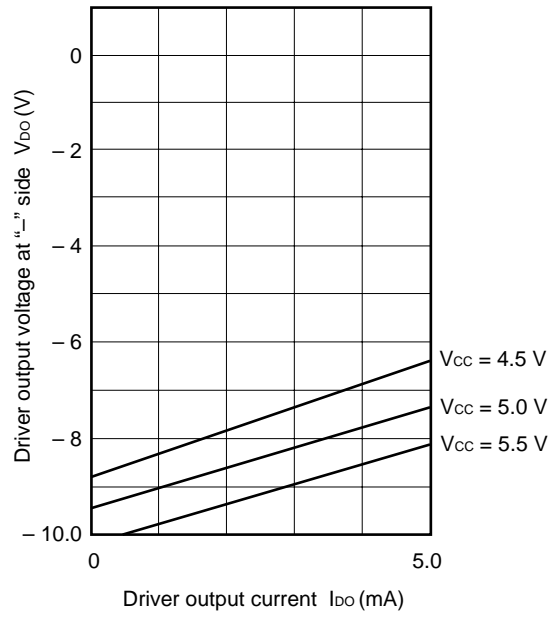
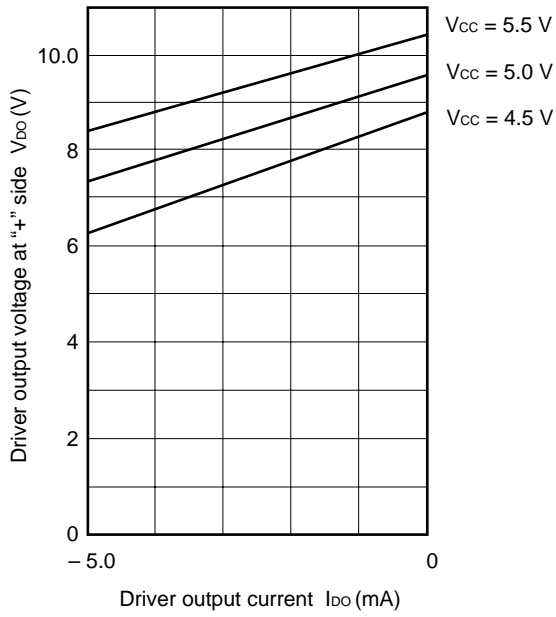

- Characteristics of driver output voltage vs. output current

(Tantalum capacitors used)

C_1 to $C_5 = 0.47 \mu\text{F}$: S981V474MB1 manufactured by Nichicon

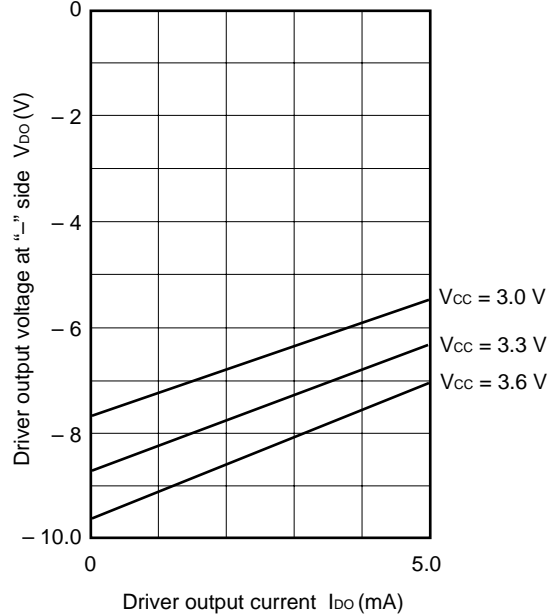
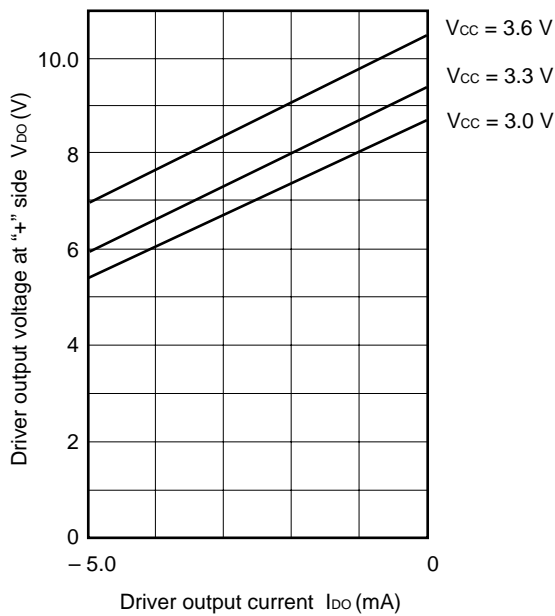
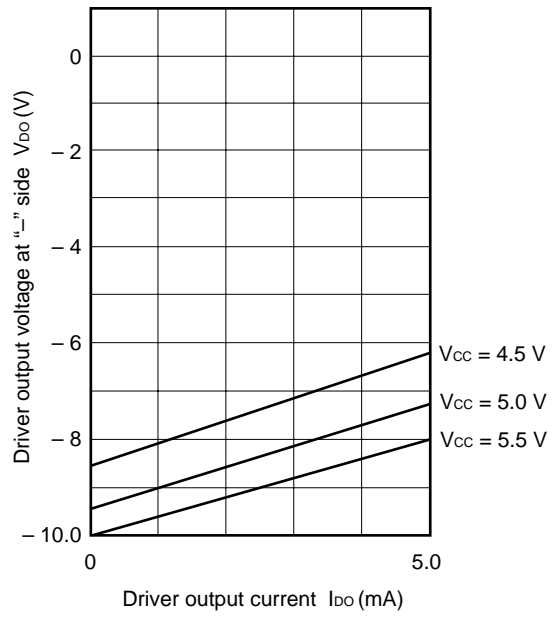
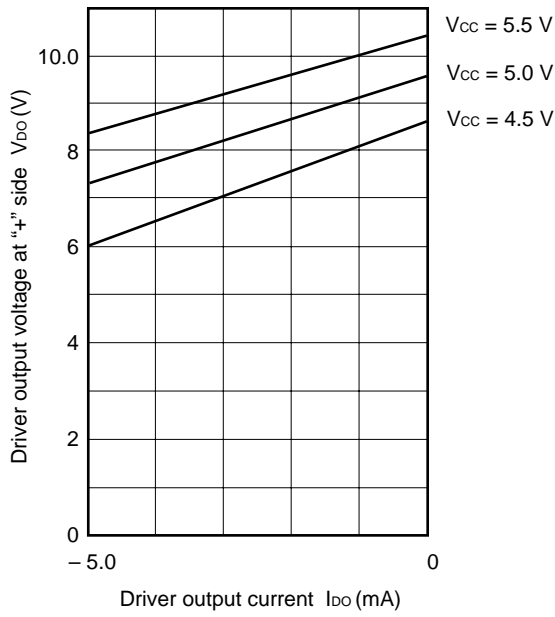

- Characteristics of driver output voltage vs. output current

(Aluminum electrolytic capacitors used)
 C_1 to $C_5 = 0.47 \mu\text{F}$: UVZ1HR47MDH manufactured by Nichicon

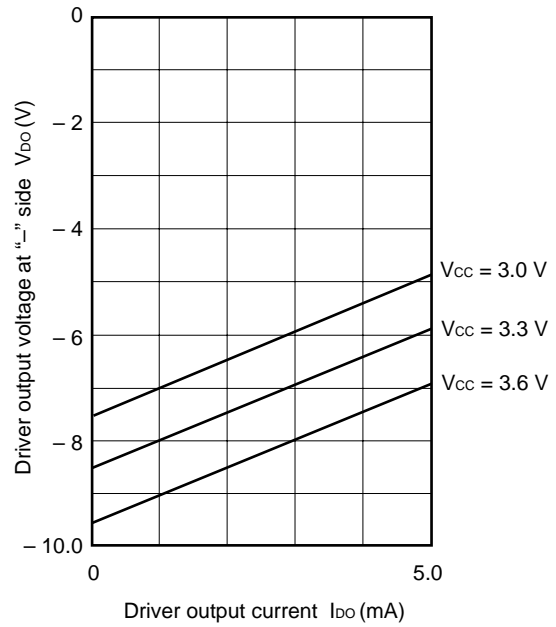
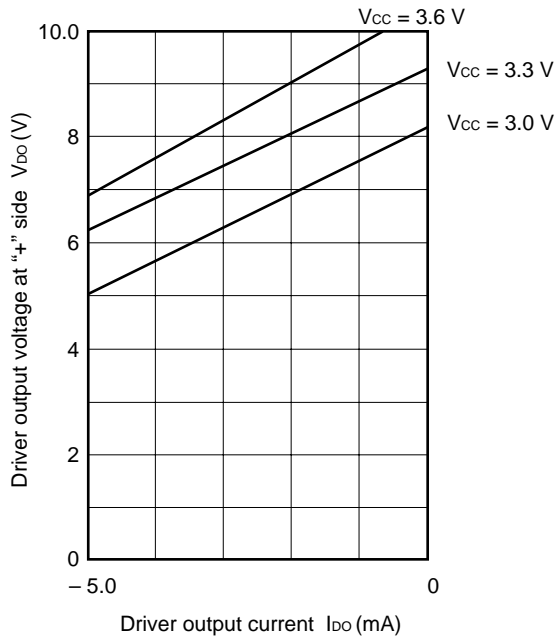
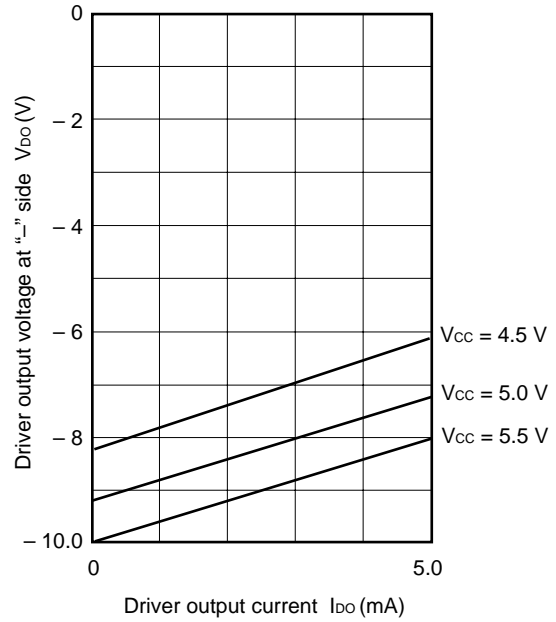
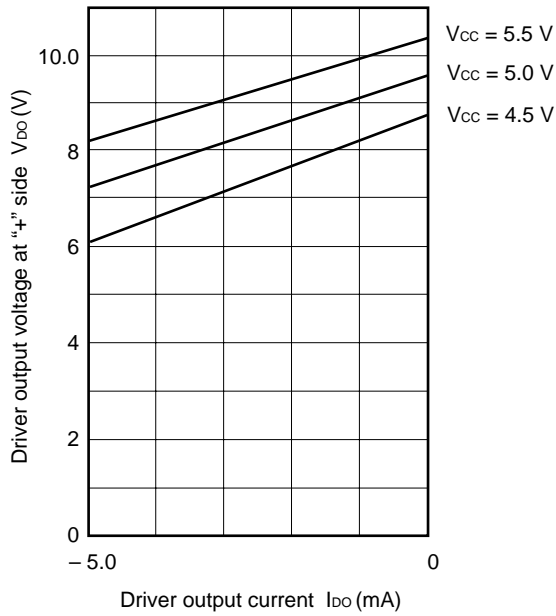

- Characteristics of driver output voltage vs. external capacitors

(Tantalum capacitors used)

$R_L = 3\text{ k}\Omega$, $T_A = 25^\circ\text{C}$

(With all driver outputs)

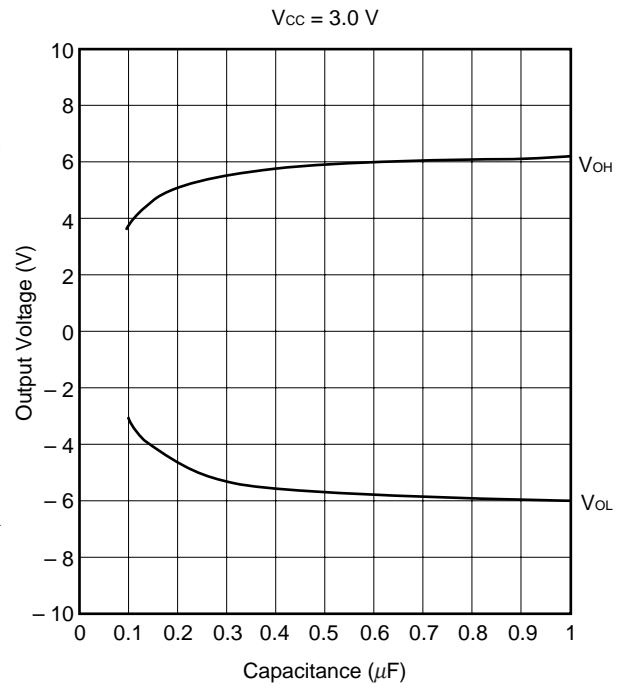
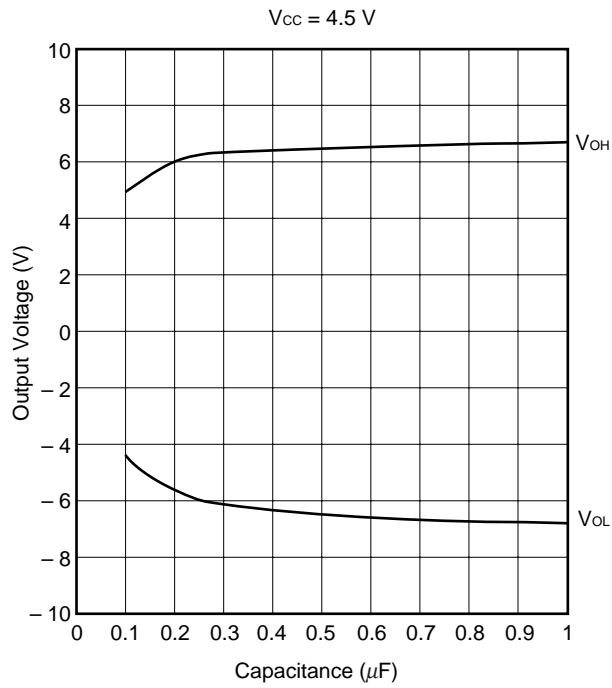

9. RS-232 STANDARD

9.1 What is the RS-232 Standard?

RS-232 is a standardized serial interface that defines the mechanical and electrical characteristics for connecting DTE (Data Terminal Equipment) and DCE (Data Communication Equipment) devices, and was developed by the EIA (Electrical Industries Association) in the U.S.A. This standard is generally called RS-232-C.

The official name of the standard is now "EIA/TIA-232-E", but "RS-232-C" is used in this document, as this term is widely used.

RS-232-C specifies electrical specifications, types of signal cables and connector specifications, and is originally referred as an interface standard to connect modems and data pins (such as PC) to each other.

The main characteristics of RS-232-C are shown below.

Characteristics of driver block

Item	Standard Value	Unit
Data transfer rate	Max.: 20	kbps
Output voltage	Max.: ± 15 (Unloaded)	V
Output voltage	Max.: ± 5 (3 k Ω)	V
Slew rate	Max.: 30	V/ns

Characteristics of receiver block

Item	Standard Value	Unit
Load capacitance	Max.: 2500 ^{Note}	pF
Threshold voltage	Max.: ± 3	V
Input resistance	3 to 7	k Ω
Input voltage	Max.: ± 25	V

Note Load capacitance is determined by type and length of signal cable and others, however, cable length is not specified in the standard.

9.2 Signal Level

Signal levels are specified in the RS-232-C standard.

Status	Low		High	
	Driver output	Receiver input	Driver output	Receiver input
Voltage level	-5 to -15 V	-3 to -25 V	+5 to +15 V	+3 to +25 V
Logical level	"1" (Mark level)		"0" (Space level)	

The signal levels in the cable are in negative logic, reversed from logical level, in the table above.

Therefore, an inverter must be inserted for a driver to output signals to the cable and a receiver must be inserted to input signals from the cable to match the internal logic (this is the role of ICs for RS-232 line driver/receivers).

Since there is a potential difference (2 V) between the driver output voltage and receiver input voltage, a noise margin or magnitude drop of up to 2 V is allowed.

9.3 Basics of RS-232-C Communication

The typical waveforms of 8-bit data transfer are shown below.

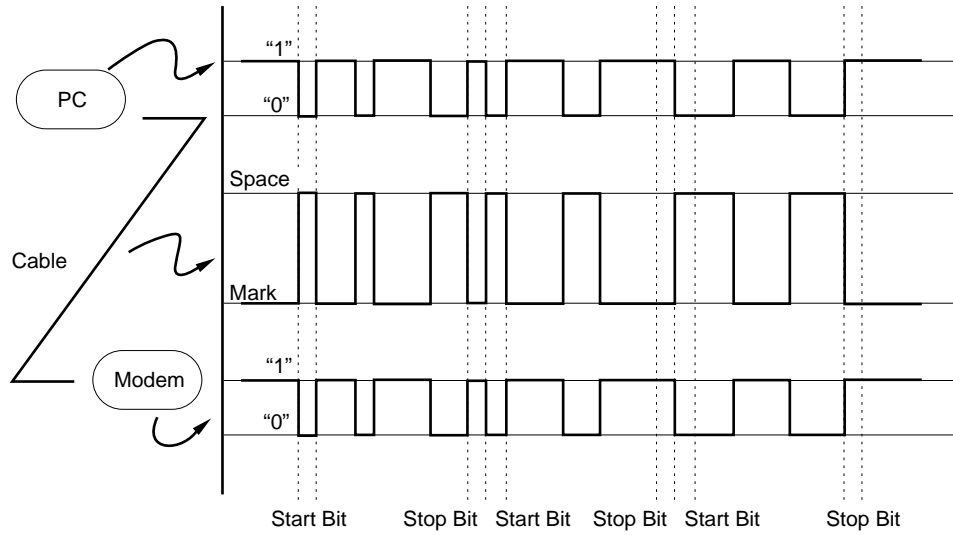

The following is defined in RS-232C communication.

- No Transfer (Idle) : Mark ("1")
- Transfer Start (Start Bit): Space ("0")
- Transfer Stop (Stop Bit) : Mark ("1")

Transfer steps are as follows:

- (1) In the Idle state, send Start Bit to start transfer.
- (2) After data transfer is completed, send Stop Bit to stop transfer.
- (3) If succeeding data is transferred, send Start Bit after Stop Bit again to transfer the data. The Idle state must be set for periods during which no data is transferred.

10. TYPICAL APPLICATION

A typical application for PC to modem communication or PC to PC communication is shown below.

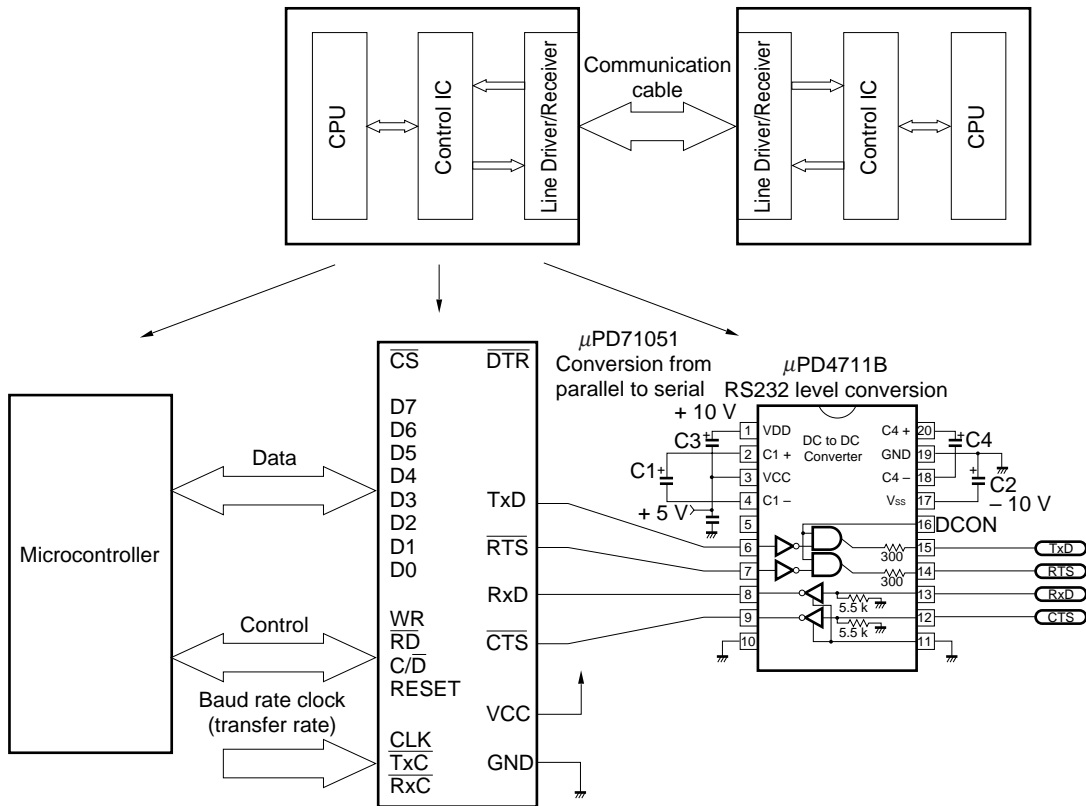

The application circuits and their parameters are for reference only and are not intended for use in actual design-ins.

11. REVISION HISTORY OF PRODUCTS

The revision history of the μ PD471X Series is shown below. Current part numbers are equivalent to discontinued part numbers on package, pin configurations, and characteristics. Therefore, customers who have been using discontinued part numbers of the μ PD471X Series can use current products without modification of board circuits etc. However, operation checks for actual applications are necessary, because actual characteristics may differ.

Part Number	Ordering Information (Discontinued)	Ordering Information (Current)	Reason of Modification
μ PD4711	μ PD4711 μ PD4711ACX/4711AGS	μ PD4711B	Process integration due to standardization of design.
μ PD4712	μ PD4712 μ PD4712ACY/4712AGT μ PD4712BCY/4712BGT	μ PD4712CCY/4712CGT μ PD4712DCY/4712DGT	
μ PD4713	μ PD4713CX/4713GT	μ PD4713ACX/4713AGT	
μ PD4714	μ PD4714CY/4714GT	μ PD4714ACY/4714AGT	
μ PD4715	μ PD4715CY/4715GT	μ PD4715ACY/4715AGT	

The revision history of the μ PD472X Series is shown below.

Current products are designed so as to raise the driven output performance, and as a result, the min. capacitance value for external capacitors is smaller. This reduction in capacitor capacitance may enable reduction of the circuit set size.

Part Number	Production Category (Previous Standard)	Capacitance of External Capacitor	Production Category (Current Standard)	Capacitance of External Capacitor	Reason of Modification
μ PD4721	E	1.0 to 4.7 μ F	P	0.33 to 4.7 μ F	Capacitance of external capacitors is lowered due to improvement of driver output capability.
μ PD4722		1.0 to 4.7 μ F		0.47 to 4.7 μ F	
μ PD4723		1.0 to 4.7 μ F		0.33 to 4.7 μ F	
μ PD4724		1.0 to 4.7 μ F		0.33 to 4.7 μ F	
μ PD4725	–	–	E	1.0 to 4.7 μ F	(No modification)

The term “current product” as used here refers to products as of May 1998.

12. Q&A

12.1 Internal Circuit Functions

Q. How is the D_{CON} pin actually used? (μ PD471X Series)

A. Idle state (No Transfer) is defined as Mark Level (“L” Output) in the RS-232 Standard. If driver input of the μ PD471X may be unstable even if it is in Normal Operation Mode (not Standby), it can be fixed to Idle state making driver output level at Mark Level, using the D_{CON} pin. This function can prevent output of abnormal signal (such as mis-recognition of the signal as Start Bit). (Refer to **6.1.2 Driver output logic**.)

Q. How is the R_{CON} pin actually used? (μ PD471X Series)

A. The space level voltage range is specified from -25 V to -3 V and the mark level voltage range is specified from $+3\text{ V}$ to $+25\text{ V}$ in the RS-232 Standard. Therefore, strictly speaking, the logic level is undefined when the cable signal is 0 V .

The input threshold voltage of the μ PD471X Series can be switched using the R_{CON} pin. The product has an A Mode, whereby the threshold voltage is set in positive, and a B Mode, whereby the threshold voltage is set in negative in order to prevent erroneous operations even if a 0-V signal is input.

If a signal with higher noise is input, a malfunction due to the smaller hysteresis width of A Mode occurs. In this case, B Mode must be used.

However, if a DC signal is output in a case such as when a control signal is transferred, signals of TTL level (0 to $+5\text{ V}$) may be easily handled. In this case, set the threshold voltage to the A mode so that signals can be recognized.

As described above, various signals can be flexibly handled by switching input threshold voltage depending on the purpose. The threshold voltage range is shown below. (Refer to **6.1.4 Receiver input threshold voltage**.)

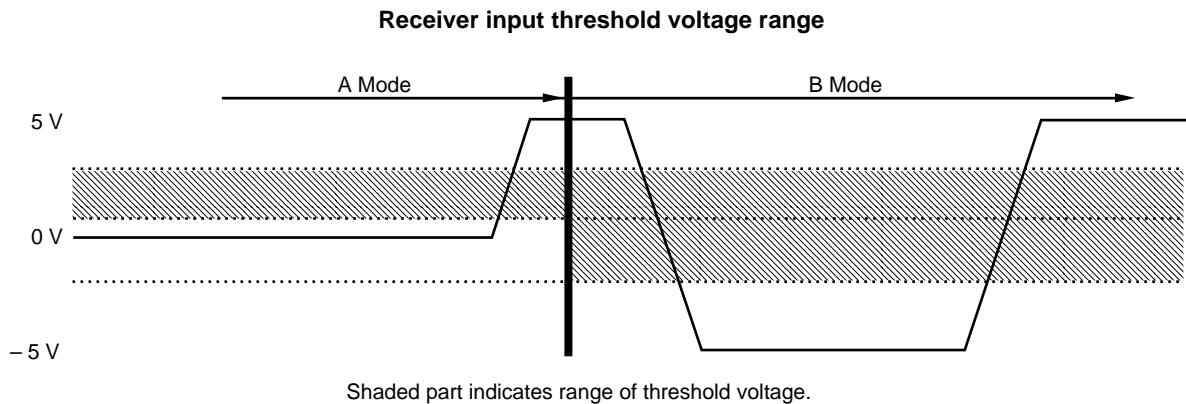

Q. How is the EN pin actually used? (μ PD472X Series)

A. The products of the μ PD472X Series (except for the μ PD4721) have a mode by which receiver input can be accepted even if it is in the Standby state. This function allows the device to use the Wake-up function, which enables operation by receiving signals from the cable.

However, the receiver with the EN pin enabled has no hysteresis width in the Standby mode (the threshold voltage is typically 1.5 V). In this case, it is recommended to apply a filter circuit to prevent erroneous operation due to noise. (Refer to **6.2.3 Receiver output logic**.)

12.2 Characteristics of Boosting Circuit

- Q. Receiver input threshold voltage exceeds the rated value.
- A. V_{DD} and V_{SS} boosted by the internal DC/DC converter circuit are used for the receiver input threshold voltage. Therefore, the cause of abnormal receiver input threshold voltage may be erroneous operation of the DC/DC converter circuit. Refer to **Q. Voltage not boosted in 12.2 Characteristics of Boosting Circuit** for measures to address improper operation of the DC/DC converter circuit.
- Q. How long does it take for the DC/DC converter to switch?
- A. Switching time can be determined by measuring C_1^+ , C_1^- , C_4^+ , and C_4^- with an oscilloscope or other device. It is designed so that the switching time is approximately 5 μ s. However, the switching time is fairly changed depending on dispersions of internal C_s and R_s which determine the time constant. Dispersion of approximately half to double of the designed value should be taken into account.
- Q. Can any current be taken out from the boosted power pins (V_{DD} and V_{SS})?
- A. The boosted power pins are voltage output pins with voltages internally boosted. They are used for driver output, setting of receiver input threshold voltage or others. Therefore, do not directly connect any loads to these pins. Just for reference, a typical characteristic when current is taken out from the V_{DD} pin of the μ PD4721 is shown in the figure below. (Refer to **7. NOTE FOR USING**.)

A typical characteristic of V_{DD} vs. Takeout Current when current is taken out from V_{DD}

(Conditions: $T_A = 25^\circ\text{C}$, $V_{CC} = 3.3\text{ V}$, C_1 to $C_5 = 0.33\ \mu\text{F}$, D_{OUT} Full Load $R_L = 3\ \text{k}\Omega$)

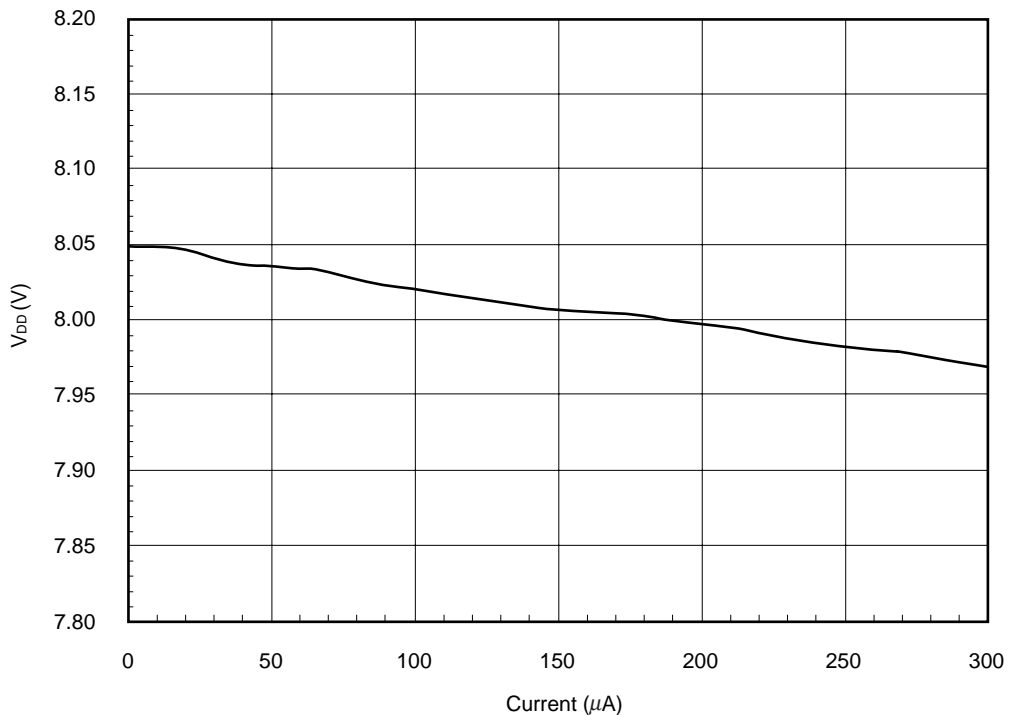

- Q. Are there any problems if two ICs are used with one common capacitor?
- A. DC/DC converters in the μ PD471X Series and μ PD472X Series are not designed expecting that two circuits are used with one common capacitor. In addition, because switching timings of capacitors cannot be externally synchronized, expected boosting operation cannot be achieved. Always use one capacitor for a single IC.
- Q. Voltage not boosted.
- A. There are several causes. Refer to the following measures.
- Noise is superposed on the power supply pin.
→ Connect a bypass capacitor between V_{CC} and GND for stabilizing. Locate the capacitor in the vicinity of the V_{CC} pin to minimize the wiring length.
 - External voltage is applied to the driver output pin before the power is turned on.
→ Internal DC/DC converter circuit may not boost the voltage, if other voltage is applied to the driver output pin from external circuit before the power is turned on.
Even if a different voltage within the rated value range is applied to the driver output pins, there is no operational problem if the IC is in operation. However, for functionality purposes, this IC is not designed expecting that another voltage will be applied to the driver output pins from an external circuit. Therefore, ensure that any other voltage is not applied to driver output pins from an external circuit.

12.3 External Capacitors

- Q. What is the withstand voltage of external capacitors?
- A. As specified in the data sheet, the following capacitors with specified withstand voltages are recommended.

Series	Withstand Voltage of External Capacitor
μ PD471X	16 V
μ PD472X	20 V

A maximum of 10 V is theoretically applied to an external capacitor as specified in the table in **DC/DC converter block** in Sections 6.1.1 and 6.2.1. However, since noise may be generated at switching, voltages with some margins (16 V or 20 V) are recommended.

- Q. What kind of capacitor is recommended?
- A. We have already confirmed that there are no problems in operation with the following capacitors after evaluation. As they are repeatedly charged and discharged by switching operation, use capacitors with better frequency characteristics.

Capacitor Type	Model
Ceramic capacitor	RPE123R474K50 (Murata Manufacturing Co., Ltd.)
Tantalum capacitor	S981V474MB1 (Nichicon)
Aluminum electrolytic capacitors	UVZ1HR47MDH (Nichicon)

(Refer to **8. TYPICAL CHARACTERISTICS** for capacitor characteristics.)

- Q. What will happen if capacitors with polarity such as Tantalum capacitor are connected in reversed polarity?
- A. If a capacitor with polarity is connected in the opposite direction from the connection diagram, the capacitor may be shorted.

Connect capacitors based on the connection diagram when connecting capacitors with polarity.

If the capacitor is shorted, refer to the next item “Q. Is the IC damaged if the capacitor is shorted?”

- Q. Is the IC damaged if the capacitor is shorted?
- A. High current may flow between V_{DD} and V_{CC} or between V_{CC} and GND if the capacitor is shorted. This high current may destroy the capacitor. Absolute maximum rating of the input current on each pin of the μ PD472X Series is specified as ± 20 mA. Therefore, excessive current over this value may destroy capacitors.

12.4 Transfer Rate

- Q. Is the operation guaranteed when using a maximum transfer rate of 115 kbps?
- A. The maximum transfer rate of the μ PD471X Series and μ PD472X Series is specified as 20 kbps. Therefore, their operation is not guaranteed with a transfer rate over 20 kbps.
- The actual transfer rate depends on the driver output load (such as signal cable length). If they are used for applications with a lower load, such as when the cable length is extremely short, transfer with rate of over 20 kbps is potentially possible.
- For your reference, actually measured values of slew rate and driver output voltage vs. transfer rate are shown on the following pages.

Measured on : μ PD4722

Measuring conditions : $T_A = 25^\circ\text{C}$, $V_{CC} = 3\text{ V}$, $C_1 - C_5 = 1\mu\text{F}$, $R_L = 3\text{ k}\Omega$, with all drivers output

Transfer rate - slew rate (at rising edge)

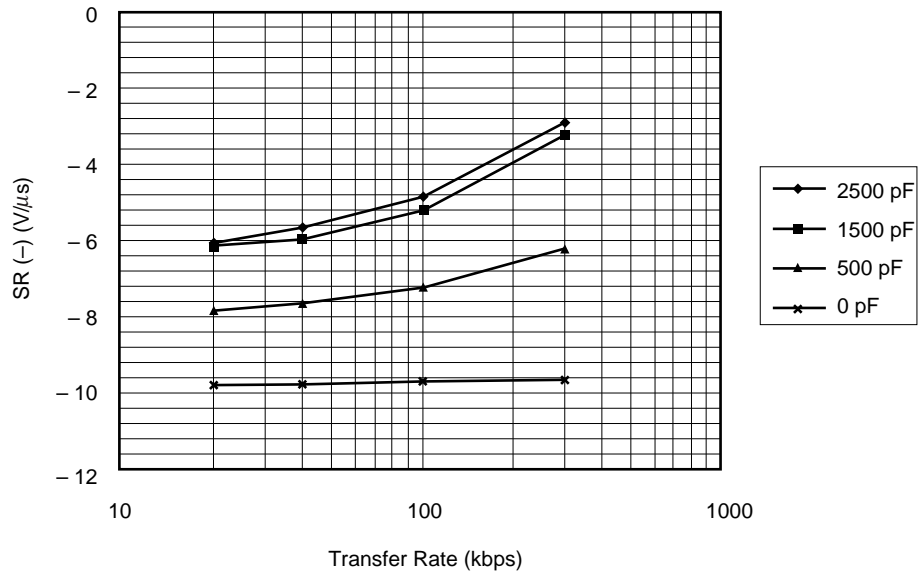

Transfer rate - slew rate (at falling edge)

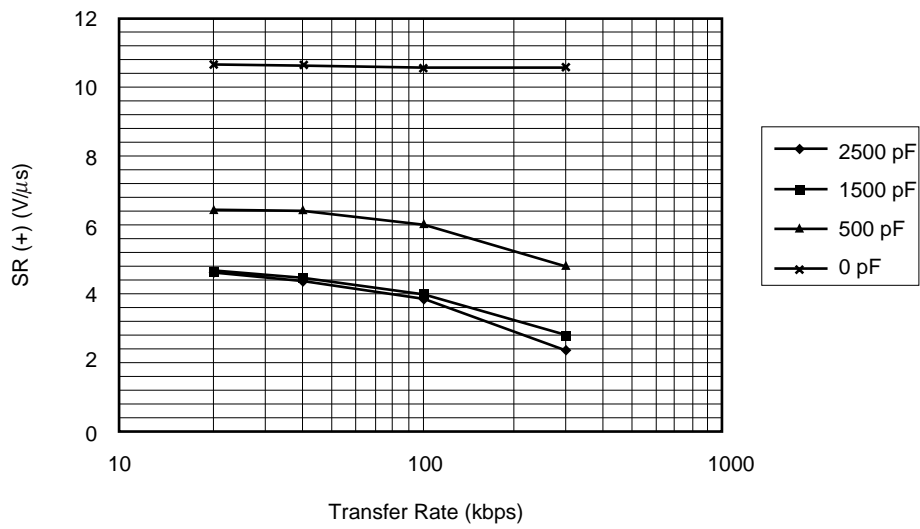

Transfer rate - driver output voltage (with output "H")

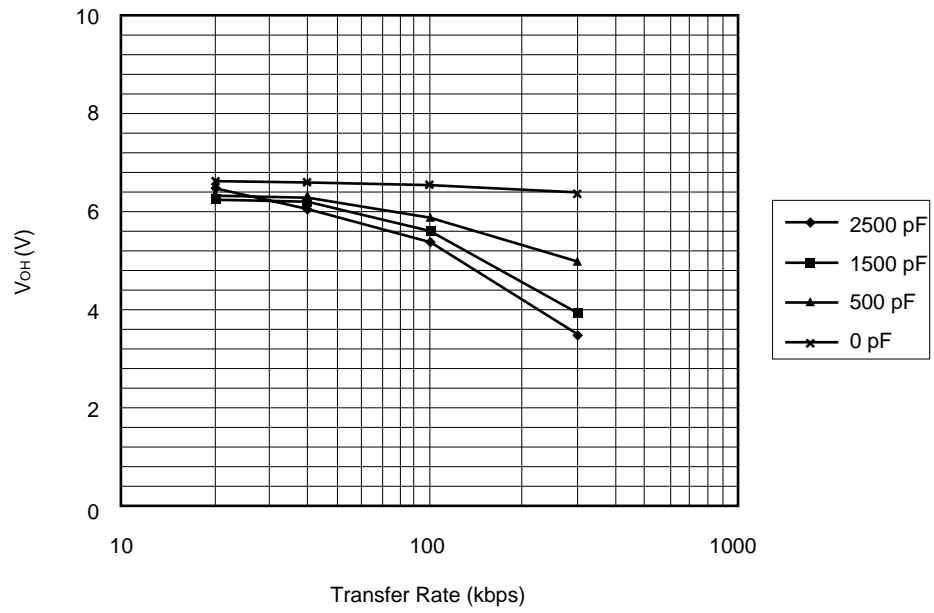

Transfer rate - driver output voltage (with output "L")

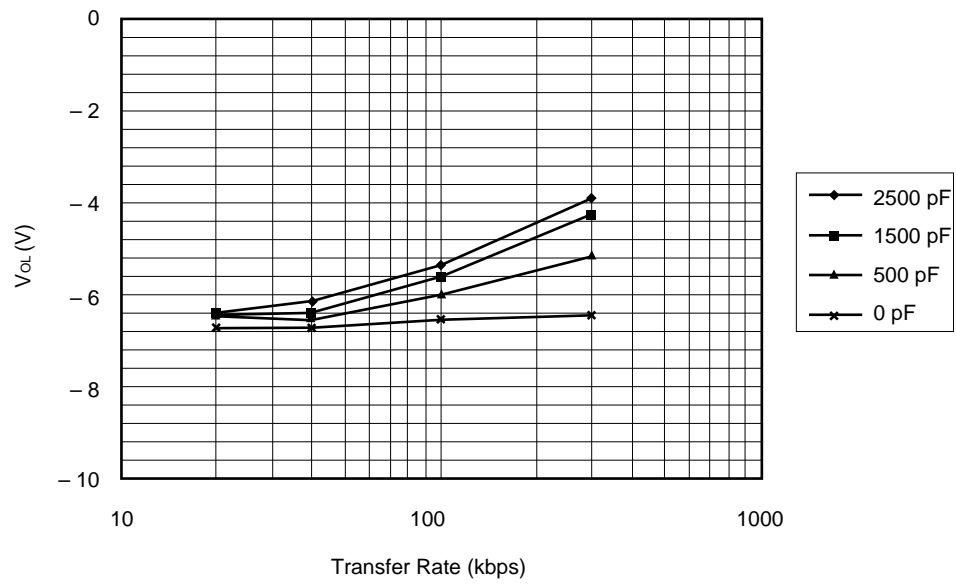

12.5 Reliability

Q. What is ESD withstand voltage?

A. These series have passed the ESD (Electrostatic Discharge) test (MIL Method, ESD Test by EIAJ Method) defined by NEC. Confirm the measured values in the ESD test by obtaining the Result Report of Reliability Testing. Request it from Reliability and Quality Control Dept. through your NEC sales representative.

Q. How are ESD protection circuits configured?

A. A protection circuit for the driver output block can be configured with a combination of Zener diodes. A sample circuit for protection is shown below. V_z of the Zener diodes should be lower than the rated voltage of the driver output (25 V) and higher than the output voltage (up to 10 V).

(Refer to **7. NOTES FOR USING**.)

Example of ESD Protection Circuit

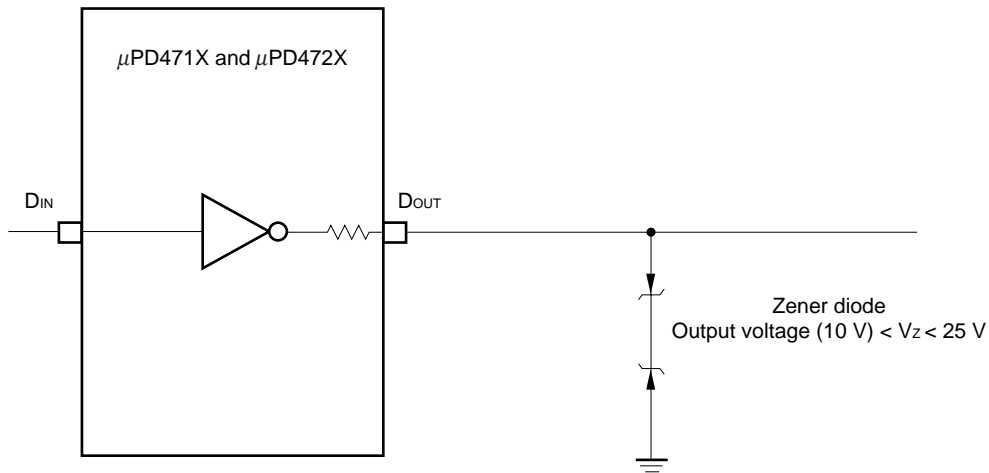

Q. What will happen if driver outputs of the transfer source and the transfer destination conflict with each other?

A. Over current between outputs may flow depending on the status of their driver outputs. For example, if the output of source is "H" and the output of destination is "L", a high current flows from the source driver to the destination driver.

In this case, the internal DC/DC converter may not be able to properly boost the voltage, and erroneous operation may result.

Therefore, do not connect driver output pins to each other.

12.6 Equivalent Products of Other Companies

Q. Give me information on equivalent products of other companies.

A. Tables of products from other companies are shown below. Refer to those tables to find equivalent NEC products starting from the part number of products of other companies.

Products operated with 5-V single power supply

Features		NEC	Maxim	National Semiconductor	Harris	Linear Technology
Driver	Receiver					
2	2	μ PD4711B	MAX202 MAX220 MAX222 MAX232/232A MAX242		HIN202 HIN232	LT1080 LT1081 LT1180 LT1181 LT1280 LT1281
3	3	μ PD4713A				
3	5	μ PD4714A		DS14185 DS14C535		LT1327 LT1337 LT1338 LT1341
4	3		MAX206 MAX236		HIN206 HIN236	
4	4	μ PD4712C/D	MAX208 MAX238	DS14C238	HIN208 HIN238	LT1134
4	5		MAX211 MAX213 MAX241	DS14C241	HIN211 HIN213	LT1136
5	3	μ PD4715A	MAX207 MAX237	DS14196	HIN207 HIN237	LT1132 LT1138
5	5		MAX240		HIN205	LT1130

Products operated with 3-V single power supply

Features		NEC	Maxim	National Semiconductor	Harris	Linear Technology
Driver	Receiver					
2	2	μ PD4721	MAX563 MAX3222 MAX3232 MAX3223	DS14C232		LTC1385 LTC1386
3	3	μ PD4723				
3	5	μ PD4724	MAX3212 MAX3243	DS14C335		LT1331 LTC1348
4	4	μ PD4722				
4	5		MAX560 MAX561			
4	7	μ PD4726				

12.7 Marking, Packages and Others

Q. Give me information on current marking.

A. The markings of the μ PD4714A and μ PD4722 (on May 1998) are shown below.

DIP package (μ PD4714ACY: μ PD471X Series)

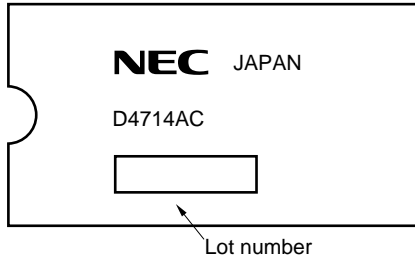

SOP package (μ PD4714AGT: μ PD471X Series)

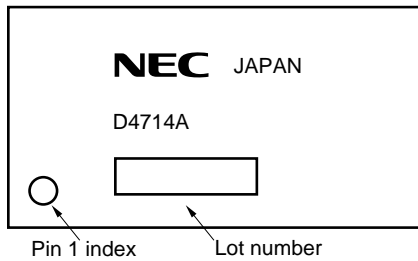

Only μ PD4711BGX has different marking for part number.
Part number: D4711BG

SSOP package (μ PD4722GS-GJG: μ PD472X Series)

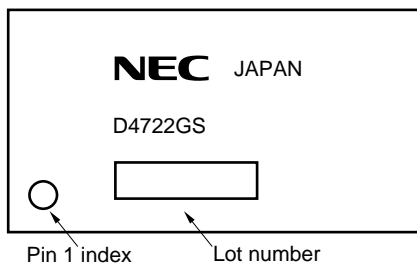

Only marking of product name of μ PD4721GX-GJG is different from others.
Part number: D4721

- Q. Give me information on the packaged quantity in a magazine and a reel
- A. Refer to the **SEMICONDUCTORS SELECTION GUIDE (X13769X)** for details on magazines and reels.
The packaged quantities of each part number and package type is shown in the table below.

DIP package (magazine)

Part Number	Packaged Quantity
μ PD4711BCX	18
μ PD4712CCY/DCY	13
μ PD4713ACX	15
μ PD4714ACY	13
μ PD4715ACY	13

SOP package (adhesive taping)

Part Number	Packaged Quantity
μ PD4711BGS	1500
μ PD4712CGT/DGT	
μ PD4713AGT	
μ PD4714AGT	
μ PD4715AGT	

SOP package (embossed taping)

Part Number	Packaged Quantity	Taping Specification
μ PD4711BGS	2500	24 mm width tape
μ PD4712CGT/DGT	1500	
μ PD4713AGT		
μ PD4714AGT		
μ PD4715AGT		

SSOP package

Part Number	Packaged Quantity	Taping Specification
μ PD4721GS-GJG	2500	16 mm width tape
μ PD4722GS-GJG		
μ PD4723GS-GJG		
μ PD4724GS-GJG		
μ PD4726GS-GJG		24 mm width tape

APPENDIX ELECTRICAL SPECIFICATIONS

The typical electrical specifications of the μ PD471X Series and μ PD472X Series are shown in the tables below. Refer to the relevant document for details.

Appendix 1. Main Characteristics of μ PD471X Series (Ex.: μ PD4714A)

Electrical specifications (common) (Unless otherwise specified, $V_{CC} = +5\text{ V} \pm 10\%$, $T_A = -20$ to $+80^\circ\text{C}$, C_1 to $C_5 = 22\ \mu\text{F}$)

Parameter	Symbol	Condition	MIN.	TYP.	MAX.	Unit
Circuit current	I_{CC1}	$V_{CC} = +5\text{ V}$, No load, R_{IN} pin open, (STBY pin open)		7.0	18.0	mA
Circuit current	I_{CC2}	$V_{CC} = +5\text{ V}$, $R_L = 3\text{ k}\Omega$ (D_{OUT}), $D_{IN} = \text{GND}$, R_{IN} , R_{OUT} pin open (STBY pin open)		23.0	40.0	mA
Circuit current at standby	I_{CC} (Standby)	$V_{CC} = +5\text{ V}$, No load, R_{IN} pin open (STBY pin high)		50	120	μA
Standby high level input voltage	V_{IH} (Standby)		2.0			V
Standby low level input voltage	V_{IL} (Standby)				0.8	V

Electrical specifications (driver) (Unless otherwise specified, $V_{CC} = +5\text{ V} \pm 10\%$, $T_A = -20$ to $+80^\circ\text{C}$, C_1 to $C_5 = 22\ \mu\text{F}$)

Parameter	Symbol	Condition	MIN.	TYP.	MAX.	Unit
Low-level input voltage	V_{IL}				0.8	V
High-level input voltage	V_{IH}		2.0			V
Low-level input current	I_{IL}		0		-1.0	μA
High-level input current	I_{IH}		0		1.0	μA
Output voltage	V_{DO}	$V_{CC} = +5.0\text{ V}$, $R_L = \infty$, $T_A = 25^\circ\text{C}$		± 9.7		V
		$V_{CC} = +5.0\text{ V}$, $R_L = 3\text{ k}\Omega$	± 5.5			V
		$V_{CC} = +4.5\text{ V}$, $R_L = 3\text{ k}\Omega$	± 5.0			V
Output short-circuit current	I_{SC}	$V_{CC} = +5.0\text{ V}$, from GND		± 15	± 40	mA
Slew rate	SR	$C_L = 10\text{ pF}$, $R_L = 3$ to $7\text{ k}\Omega$	1.5	9	30	V/ μs
		$C_L = 2500\text{ pF}$, $R_L = 3$ to $7\text{ k}\Omega$	1.5	5	30	V/ μs
Transfer delay time	t_{PHL}	$R_L = 3\text{ k}\Omega$, $C_L = 2500\text{ pF}$		0.8		μs
	t_{PLH}					
Output resistance	R_O	$V_{CC} = V_{DD} = V_{SS} = 0\text{ V}$, $V_{OUT} = \pm 2\text{ V}$	300	500		Ω
Standby output transition time	t_{DAZ}	$R_L = 3\text{ k}\Omega$, $C_L = 2500\text{ pF}$		4	10	μs
Standby output transition time	t_{DZA}	$R_L = 3\text{ k}\Omega$, $C_L = 2500\text{ pF}$		25	50	ms

Electrical specifications (receiver) (Unless otherwise specified, $V_{CC} = +5\text{ V} \pm 10\%$, $T_A = -20\text{ to }+80^\circ\text{C}$, $C_1\text{ to }C_5 = 22\ \mu\text{F}$)

Parameter	Symbol	Condition	MIN.	TYP.	MAX.	Unit
Low-level output voltage	V_{OL}	$I_{OUT} = 4\text{ mA}$			0.4	V
High-level output voltage	V_{OH}	$I_{OUT} = -4\text{ mA}$	$V_{CC} - 0.8$			V
Low-level input voltage	V_{OL}	R_{CON} pin			0.8	V
High-level input voltage	V_{OH}	R_{CON} pin	2.0			V
Propagation delay time	t_{PHL} t_{PLH}	$R_L = 1\text{ k}\Omega$, $C_L = 150\text{ pF}$		0.13		μs
Input resistance	R_i		3	5	7	$\text{k}\Omega$
Input open circuit voltage	V_{IO}	Input threshold A mode only.			0.5	V
Threshold A mode (R_{CON} pin Low)	V_{IH}	$V_{CC} = +5\text{ V}$	1.7	2.3	2.7	V
	V_{IL}	$V_{CC} = +5\text{ V}$	0.7	1.1	1.7	V
	V_H	$V_{CC} = +5\text{ V}$ (Hysteresis width)	0.5	1.2	1.8	V
Threshold B mode (R_{CON} pin High)	V_{IH}	$V_{CC} = +5\text{ V}$	1.6	2.2	2.6	V
	V_{IL}	$V_{CC} = +5\text{ V}$	-0.4	-1.8	-3.0	V
	V_H	$V_{CC} = +5\text{ V}$ (Hysteresis width)	2.6	4.0	5.4	V
Standby output transition time	t_{DAZ}			0.4	1	μs
Standby output transition time	t_{DZA}			1.0	10	ms

Appendix 2. Main Characteristics of μ PD472X Series (Ex.: μ PD4724)

Electrical specifications (common) (Unless otherwise specified, $T_A = -40$ to $+85^\circ\text{C}$, C_1 to $C_5 = 1 \mu\text{F}$)

Parameter	Symbol	Condition	MIN.	TYP.	MAX.	Unit
Circuit current	I_{CC1}	$V_{CC} = +3.3 \text{ V}$, No load, R_{IN} pin open, $\overline{STBY} = H$		7.5	15	mA
		$V_{CC} = +5.0 \text{ V}$, No load, R_{IN} pin open, $\overline{STBY} = H$		5.5	11	mA
Circuit current	I_{CC2}	$V_{CC} = +3.3 \text{ V}$, $R_L = 3 \text{ k}\Omega$ (D_{OUT}), $D_{IN} = GND$, R_{IN} , R_{OUT} pin open, $\overline{STBY} = H$		25	35	mA
		$V_{CC} = +5.0 \text{ V}$, $R_L = 3 \text{ k}\Omega$ (D_{OUT}), $D_{IN} = GND$, R_{IN} , R_{OUT} pin open, $\overline{STBY} = H$		19	28	mA
Circuit current at standby (Standby mode 1)	I_{CC3}	$V_{CC} = +3.3 \text{ V}$, No load, D_{IN} , R_{IN} pin open $\overline{STBY} = L$, $EN = L$, $T_A = 25^\circ\text{C}$		1	3	μA
		$V_{CC} = +5.0 \text{ V}$, No load, D_{IN} , R_{IN} pin open $\overline{STBY} = L$, $EN = L$, $T_A = 25^\circ\text{C}$		2	5	μA
Circuit current at standby (Standby mode 2)	I_{CC4}	$V_{CC} = +3.3 \text{ V}$, No load, D_{IN} , R_{IN} pin open $\overline{STBY} = L$, $EN = H$, $T_A = 25^\circ\text{C}$		1	3	μA
		$V_{CC} = +5.0 \text{ V}$, No load, D_{IN} , R_{IN} pin open $\overline{STBY} = L$, $EN = H$, $T_A = 25^\circ\text{C}$		2	5	μA
High-level input voltage	V_{IH}	$V_{CC} = +3.0$ to $+5.5 \text{ V}$, \overline{STBY} , V_{CHA} , EN pin	2.4			V
Low-level input voltage	V_{IL}	$V_{CC} = +3.0$ to $+5.5 \text{ V}$, \overline{STBY} , V_{CHA} , EN pin			0.6	V

Electrical specifications (driver) (Unless otherwise specified, $T_A = -40$ to $+85^\circ\text{C}$, C_1 to $C_5 = 1 \mu\text{F}$)

3-V mode (Unless otherwise specified, $V_{CHA} = H$, $V_{CC} = 3.0$ to 3.6 V)

Parameter	Symbol	Condition	MIN.	TYP.	MAX.	Unit
Low-level input voltage	V_{IL}				0.8	V
High-level input voltage	V_{IH}		2.0			V
Low-level input current	I_{IL}	$V_{CC} = +3.6 \text{ V}$, $V_I = 0 \text{ V}$			-25	μA
High-level input current	I_{IH}	$V_{CC} = +3.6 \text{ V}$, $V_I = +3.6 \text{ V}$			1.0	μA
Output voltage	V_{DO}	$V_{CC} = +3.3 \text{ V}$, $R_L = \infty$, $T_A = 25^\circ\text{C}$		± 9.5		V
		$V_{CC} = +3.3 \text{ V}$, $R_L = 3 \text{ k}\Omega$	± 5.0	± 6.0		V
		$V_{CC} = +3.0 \text{ V}$, $R_L = 3 \text{ k}\Omega$, $T_A = 25^\circ\text{C}$	± 5.0			V
Output short-circuit current	I_{SC}	$V_{CC} = +3.3 \text{ V}$, from GND			± 40	mA
Slew rate	SR	$C_L = 10 \text{ pF}$, $R_L = 3$ to $7 \text{ k}\Omega$	3.0		30	V/ μs
		$C_L = 2500 \text{ pF}$, $R_L = 3$ to $7 \text{ k}\Omega$	3.0		30	V/ μs
Transfer delay time	t_{PHL}	$R_L = 3 \text{ k}\Omega$, $C_L = 2500 \text{ pF}$		2.5		μs
	t_{PLH}					
Output resistance	R_O	$V_{CC} = V_{DD} = V_{SS} = 0 \text{ V}$, $V_{OUT} = \pm 2 \text{ V}$	300			Ω
Standby output transition time	t_{DAZ}	$R_L = 3 \text{ k}\Omega$, $C_L = 2500 \text{ pF}$		4	10	μs
Standby output transition time	t_{DZA}	$R_L = 3 \text{ k}\Omega$, $C_L = 2500 \text{ pF}$		1	3	ms
Power on output transition time	t_{PRA}	$R_L = 3 \text{ k}\Omega$, $C_L = 2500 \text{ pF}$		1	3	ms

Electrical specifications (driver) (Unless otherwise specified, $T_A = -40$ to $+85^\circ\text{C}$, C_1 to $C_5 = 1\ \mu\text{F}$)

5-V mode (Unless otherwise specified, $V_{CHA} = L$, $V_{CC} = 5.0\ \text{V} \pm 10\%$)

Parameter	Symbol	Condition	MIN.	TYP.	MAX.	Unit
Low-level input voltage	V_{IL}				0.8	V
High-level input voltage	V_{IH}		2.0			V
Low-level input current	I_{IL}	$V_{CC} = +5.5\ \text{V}$, $V_I = 0\ \text{V}$			-40	μA
High-level input current	I_{IH}	$V_{CC} = +5.5\ \text{V}$, $V_I = +5.5\ \text{V}$			1.0	μA
Output voltage	V_{DO}	$V_{CC} = +5.0\ \text{V}$, $R_L = \infty$, $T_A = 25^\circ\text{C}$		± 9.7		V
		$V_{CC} = +5.0\ \text{V}$, $R_L = 3\ \text{k}\Omega$	± 6.0			V
		$V_{CC} = +4.5\ \text{V}$, $R_L = 3\ \text{k}\Omega$	± 5.0			V
Output short-circuit current	I_{SC}	$V_{CC} = +5.0\ \text{V}$, from GND			± 40	mA
Slew rate	SR	$C_L = 10\ \text{pF}$, $R_L = 3$ to $7\ \text{k}\Omega$	4.0		30	V/ μs
		$C_L = 2500\ \text{pF}$, $R_L = 3$ to $7\ \text{k}\Omega$	4.0		30	V/ μs
Transfer delay time	t_{PHL}	$R_L = 3\ \text{k}\Omega$, $C_L = 2500\ \text{pF}$		2		μs
	t_{PLH}					
Output resistance	R_O	$V_{CC} = V_{DD} = V_{SS} = 0\ \text{V}$, $V_{OUT} = \pm 2\ \text{V}$	300			Ω
Standby output transition time	t_{DAZ}	$R_L = 3\ \text{k}\Omega$, $C_L = 2500\ \text{pF}$		4	10	μs
Standby output transition time	t_{DZA}	$R_L = 3\ \text{k}\Omega$, $C_L = 2500\ \text{pF}$		0.5	1	ms
Power on output transition time	t_{PRA}	$R_L = 3\ \text{k}\Omega$, $C_L = 2500\ \text{pF}$		0.5	1	ms

Electrical specifications (receiver) (Unless otherwise specified, $V_{CC} = 3.0$ to $5.5\ \text{V}$, $T_A = -40$ to $+85^\circ\text{C}$, C_1 to $C_5 = 1\ \mu\text{F}$)

Parameter	Symbol	Condition	MIN.	TYP.	MAX.	Unit
Low level-output voltage	V_{OL1}	$I_{OUT} = 4\ \text{mA}$, $\overline{\text{STBY}} = H$			0.4	V
High level-output voltage	V_{OH1}	$I_{OUT} = -4\ \text{mA}$, $\overline{\text{STBY}} = H$	$V_{CC} - 0.4$			V
Low level-output voltage	V_{OL2}	$I_{OUT} = 4\ \text{mA}$, $\overline{\text{STBY}} = L$			0.5	V
High level-output voltage	V_{OH2}	$I_{OUT} = -4\ \text{mA}$, $\overline{\text{STBY}} = L$	$V_{CC} - 0.5$			V
Transfer delay time (STBY = H)	t_{PHL}	$R_{IN} \rightarrow R_{OUT}$, $C_L = 150\ \text{pF}$, $V_{CC} = +3.0\ \text{V}$		0.2		μs
	t_{PLH}					
Transfer delay time (STBY = L)	t_{PHL}	$R_{IN} \rightarrow R_{OUT}$, $C_L = 150\ \text{pF}$, $V_{CC} = +3.0\ \text{V}$		0.1		μs
	t_{PLH}					
Transfer delay time (STBY = L)	t_{PHA}	$R_{IN} \rightarrow R_{OUT}$, $C_L = 150\ \text{pF}$, $V_{CC} = +3.0\ \text{V}$		100	300	ns
	t_{PAH}					
Input resistance	R_I		3	5.5	7	$\text{k}\Omega$
Input open circuit voltage	V_{IO}				0.5	V
Threshold (STBY = H)	V_{IH}	$V_{CC} = +3.0$ to $+5.5\ \text{V}$	1.7	2.3	2.7	V
	V_{IL}	$V_{CC} = +3.0$ to $+5.5\ \text{V}$	0.7	1.1	1.7	V
	V_H	$V_{CC} = +3.0$ to $+5.5\ \text{V}$ (Hysteresis width)	0.5	1.2	1.8	V
Threshold ($\overline{\text{STBY}} = L$, EN = H)	V_{IH}	$V_{CC} = +3.0$ to $+5.5\ \text{V}$, R_{IN4} , R_{IN5}	2.7	1.5		V
	V_{IL}	$V_{CC} = +3.0$ to $+5.5\ \text{V}$, R_{IN4} , R_{IN5}		1.5	0.7	V
Standby output transition time	t_{DAH}			0.2	3	μs
Standby output transition time	t_{DHA}	$V_{CHA} = H$ (3-V mode)		0.6	3	ms
		$V_{CHA} = L$ (5-V mode)		0.3	1	ms
Power on reset release time	t_{PRA}	$V_{CHA} = H$ (3-V mode)		1	3	ms
		$V_{CHA} = L$ (5-V mode)		0.5	1	ms

[MEMO]

Facsimile Message

Although NEC has taken all possible steps to ensure that the documentation supplied to our customers is complete, bug free and up-to-date, we readily accept that errors may occur. Despite all the care and precautions we've taken, you may encounter problems in the documentation. Please complete this form whenever you'd like to report errors or suggest improvements to us.

From:

Name

Company

Tel.

FAX

Address

Thank you for your kind support.

North America

NEC Electronics Inc.
Corporate Communications Dept.
Fax: 1-800-729-9288
1-408-588-6130

Hong Kong, Philippines, Oceania

NEC Electronics Hong Kong Ltd.
Fax: +852-2886-9022/9044

Asian Nations except Philippines

NEC Electronics Singapore Pte. Ltd.
Fax: +65-250-3583

Europe

NEC Electronics (Europe) GmbH
Technical Documentation Dept.
Fax: +49-211-6503-274

Korea

NEC Electronics Hong Kong Ltd.
Seoul Branch
Fax: 02-528-4411

Japan

NEC Semiconductor Technical Hotline
Fax: 044-548-7900

South America

NEC do Brasil S.A.
Fax: +55-11-6465-6829

Taiwan

NEC Electronics Taiwan Ltd.
Fax: 02-2719-5951

I would like to report the following error/make the following suggestion:

Document title: _____

Document number: _____

Page number: _____

If possible, please fax the referenced page or drawing.

Document Rating	Excellent	Good	Acceptable	Poor
Clarity	<input type="checkbox"/>	<input type="checkbox"/>	<input type="checkbox"/>	<input type="checkbox"/>
Technical Accuracy	<input type="checkbox"/>	<input type="checkbox"/>	<input type="checkbox"/>	<input type="checkbox"/>
Organization	<input type="checkbox"/>	<input type="checkbox"/>	<input type="checkbox"/>	<input type="checkbox"/>