

To all our customers

Regarding the change of names mentioned in the document, such as Mitsubishi Electric and Mitsubishi XX, to Renesas Technology Corp.

The semiconductor operations of Hitachi and Mitsubishi Electric were transferred to Renesas Technology Corporation on April 1st 2003. These operations include microcomputer, logic, analog and discrete devices, and memory chips other than DRAMs (flash memory, SRAMs etc.) Accordingly, although Mitsubishi Electric, Mitsubishi Electric Corporation, Mitsubishi Semiconductors, and other Mitsubishi brand names are mentioned in the document, these names have in fact all been changed to Renesas Technology Corp. Thank you for your understanding. Except for our corporate trademark, logo and corporate statement, no changes whatsoever have been made to the contents of the document, and these changes do not constitute any alteration to the contents of the document itself.

Note : Mitsubishi Electric will continue the business operations of high frequency & optical devices and power devices.

Renesas Technology Corp.
Customer Support Dept.
April 1, 2003

MITSUBISHI IGBT
CY25AAJ-8

Nch IGBT for STROBE FLASHER

CY25AAJ-8

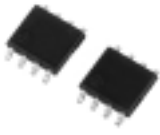

- VCES 400V
- ICM 150A
- Drive voltage 4V

OUTLINE DRAWING Dimensions in mm

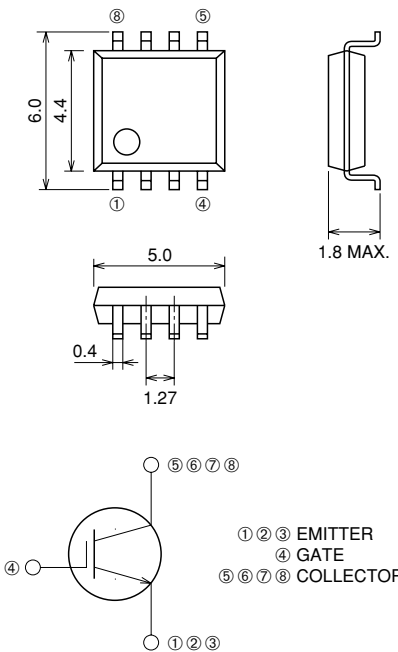

SOP-8

APPLICATION

Strobe flasher for Camera

MAXIMUM RATINGS (Tc = 25°C)

Symbol	Parameter	Conditions	Ratings	Unit
V _{CE} S	Collector-emitter voltage	V _{GE} = 0V	400	V
V _{GE} S	Gate-emitter voltage	V _{CE} = 0V	±6	V
V _{GEM}	Peak gate-emitter voltage	V _{CE} = 0V, t _w = 10s	±8	V
I _{CM}	Collector current (Pulsed)	C _M = 400μF see figure1	150	A
T _j	Junction temperature		-40 ~ +150	°C
T _{stg}	Storage temperature		-40 ~ +150	°C

ELECTRICAL CHARACTERISTICS (T_J = 25°C)

Symbol	Parameter	Test conditions	Limits			Unit
			Min.	Typ.	Max.	
V (BR) CES	Collector-emitter breakdown voltage	I _C = 1mA, V _{GE} = 0V	450	—	—	V
I _{CES}	Collector-emitter leakage current	V _{CE} = 400V, V _{GE} = 0V	—	—	10	μA
I _{GES}	Gate-emitter leakage current	V _{GE} = ±6V, V _{CE} = 0V	—	—	±0.1	μA
V _{GE} (th)	Gate-emitter threshold voltage	V _{CE} = 10V, I _C = 1mA	—	—	1.5	V

Figure1. MAXIMUM PULSE COLLECTOR CURRENT

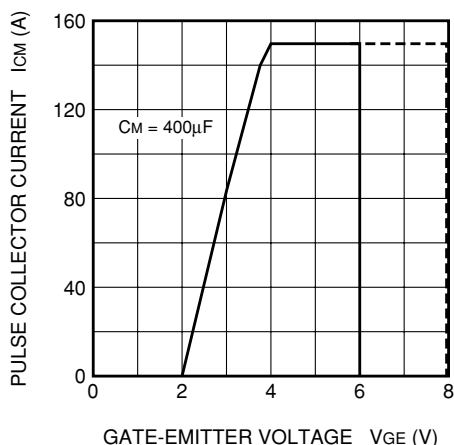

APPLICATION EXAMPLE

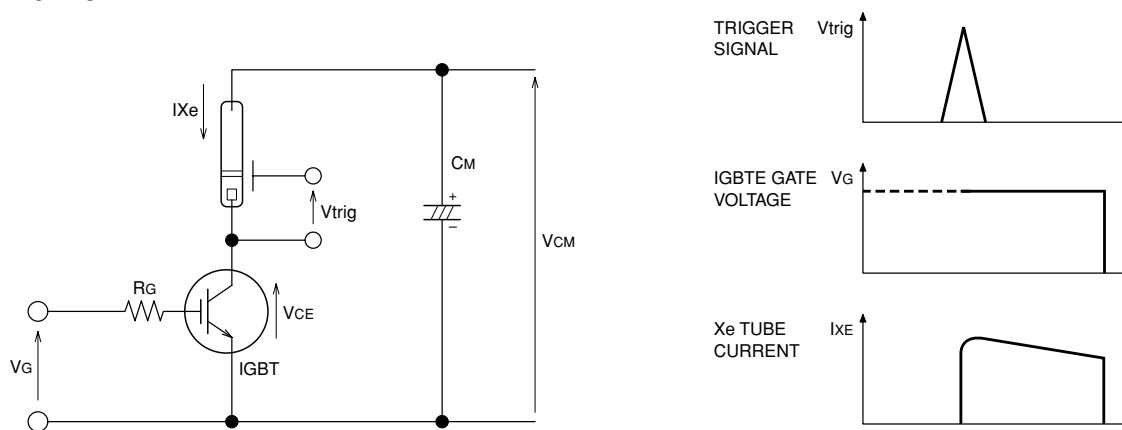

Recommended operation conditions	Maximum operation conditions
V _{CM} = 330V	V _{CM} = 350V
I _{CP} = 130A	I _{CP} = 150A
C _M = 330μF	C _M = 400μF
V _{GE} = 5V	

- Notice 1. Gate drive voltage during on-state must be applied to satisfy the rating of maximum pulse collector current. And peak reverse gate current during turn-off must become less than 0.1A. (In general, when R_G (off) = 30Ω, it is satisfied.)
- Notice 2. IGBT has MOS structure and its gate is insulated by thin silicon oxide. So please handle carefully not to give static electricity.
- Notice 3. The operation life should be endured 5,000 shots under the charge current (I_{Xe} ≤ 150A : full luminescence condition) of main condenser (C_M = 400μF). Repetitive period under the full luminescence conditions is over 3 seconds.
- Notice 4. Total gate operation time must be applied within 5,000 hours.