

1. Description

The AR0521D5 is a bi-directional TVS diode, provide fast re-sponse time and low ESD clamping voltage, making this device an ideal solution for protecting voltage sensitive high-speed data lines. The AR0521D5 has an ultra-low capacitance with a typical value at 0.3pF, and with $\pm 25\text{kV}$ air and $\pm 22\text{kV}$ contact discharge.

3. Features

- Ultra low capacitance: 0.3pF typical
- Ultra low leakage: nA level
- Operating voltage: 5V
- Low clamping voltage

4. Pinning information

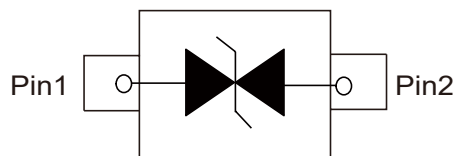

SOD-523

2. Applications

- Cellular Handsets and Accessories
- Display Ports
- MDDI Ports
- USB Ports
- Digital Visual Interface (DVI)
- PCI Express and Serial SATA Ports

- Complies with following standards:
 - IEC 61000-4-2 (ESD) immunity test
 - Air discharge: $\pm 25\text{kV}$
 - Contact discharge: $\pm 22\text{kV}$
 - IEC61000-4-5 (Lightning) 4A (8/20 μs)



5. Absolute Maximum Ratings ($T_A=25^\circ\text{C}$ unless otherwise specified)

Parameter	Symbol	Value	Units
Peak Pulse Power (8/20 μs)	P_{PK}	100	W
Peak Pulse Current (8/20 μs)	I_{PP}	4	A
ESD per IEC 61000-4-2 (Air)	V_{ESD}	± 25	kV
ESD per IEC 61000-4-2 (Contact)		± 22	kV
Junction Temperature	T_J	-55 to 125	$^\circ\text{C}$
Storage Temperature Range	T_{STG}	-55 to 150	$^\circ\text{C}$

6. Electrical Characteristic ($T_A=25^\circ\text{C}$ unless otherwise noted)

Parameter	Symbol	Conditions	Min	Typ	Max	Units
Reverse Working Voltage	V_{RWM}				5	V
Breakdown Voltage	V_{BR}	$I_T=1\text{mA}$	6.5		9.5	V
Reverse Leakage Current	I_R	$V_{RWM}=5\text{V}$		0.02	0.2	μA
Clamping Voltage	V_C	$I_{PP}=1\text{A}(8 \times 20\mu\text{s pulse})$			12	V
Clamping Voltage	V_C	$I_{PP}=4\text{A}(8 \times 20\mu\text{s pulse})$			25	V
Junction Capacitance	C_J	$V_R=0\text{V}, f=1\text{MHz}$		0.3	0.5	pF



7. Typical characteristic

<p>Figure 1: Junction Capacitance vs. Reverse Voltage</p>	<p>Figure 2: Clamping Voltage vs. Peak Pulse Current</p>
<p>Figure 3: Peak Pulse Power vs. Pulse Time</p>	<p>Figure 4: IEC61000-4-2 Pulse Waveform</p>
<p>Figure 5: Power Derating Curve</p>	<p>Figure 6: Data is taken with a 10x attenuator ESD Clamping Voltage</p>



8.SOD-523 Package Outline Dimensions

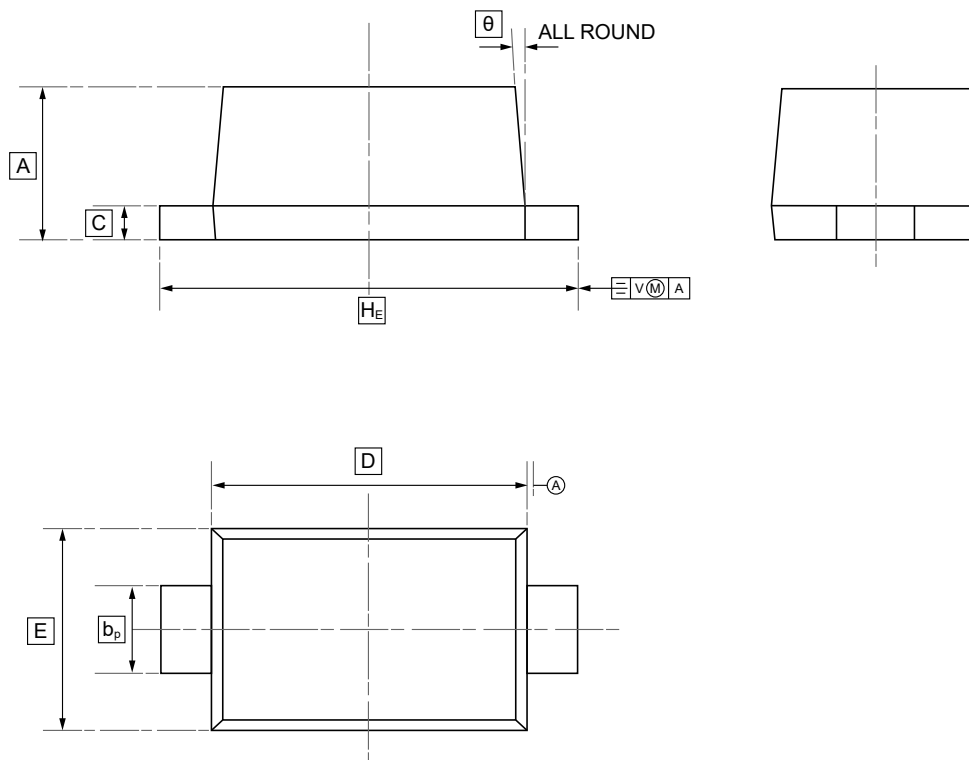

DIMENSIONS (mm are the original dimensions)

Symbol	A	b _p	C	D	E	H _E	θ
Min	0.58	0.3	0.100	1.15	0.75	1.5	5°
Max	0.68	0.4	0.135	1.25	0.85	1.7	



9. Ordering information

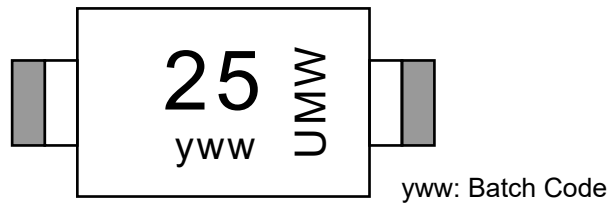

Order Code	Package	Base QTY	Delivery Mode
UMW AR0521D5	SOD-523	3000	Tape and reel



10.Disclaimer

UMW reserves the right to make changes to all products, specifications. Customers should obtain the latest version of product documentation and verify the completeness and currency of the information before placing an order.

When applying our products, please do not exceed the maximum rated values, as this may affect the reliability of the entire system. Under certain conditions, any semiconductor product may experience faults or failures. Buyers are responsible for adhering to safety standards and implementing safety measures during system design, prototyping, and manufacturing when using our products to prevent potential failure risks that could lead to personal injury or property damage.

Unless explicitly stated in writing, UMW products are not intended for use in medical, life-saving, or life-sustaining applications, nor for any other applications where product failure could result in personal injury or death. If customers use or sell the product for such applications without explicit authorization, they assume all associated risks.

When reselling, applying, or exporting, please comply with export control laws and regulations of China, the United States, the United Kingdom, the European Union, and other relevant countries, regions, and international organizations.

This document and any actions by UMW do not grant any intellectual property rights, whether express or implied, by estoppel or otherwise. The product names and marks mentioned herein may be trademarks of their respective owners.