

Pin Arrangement

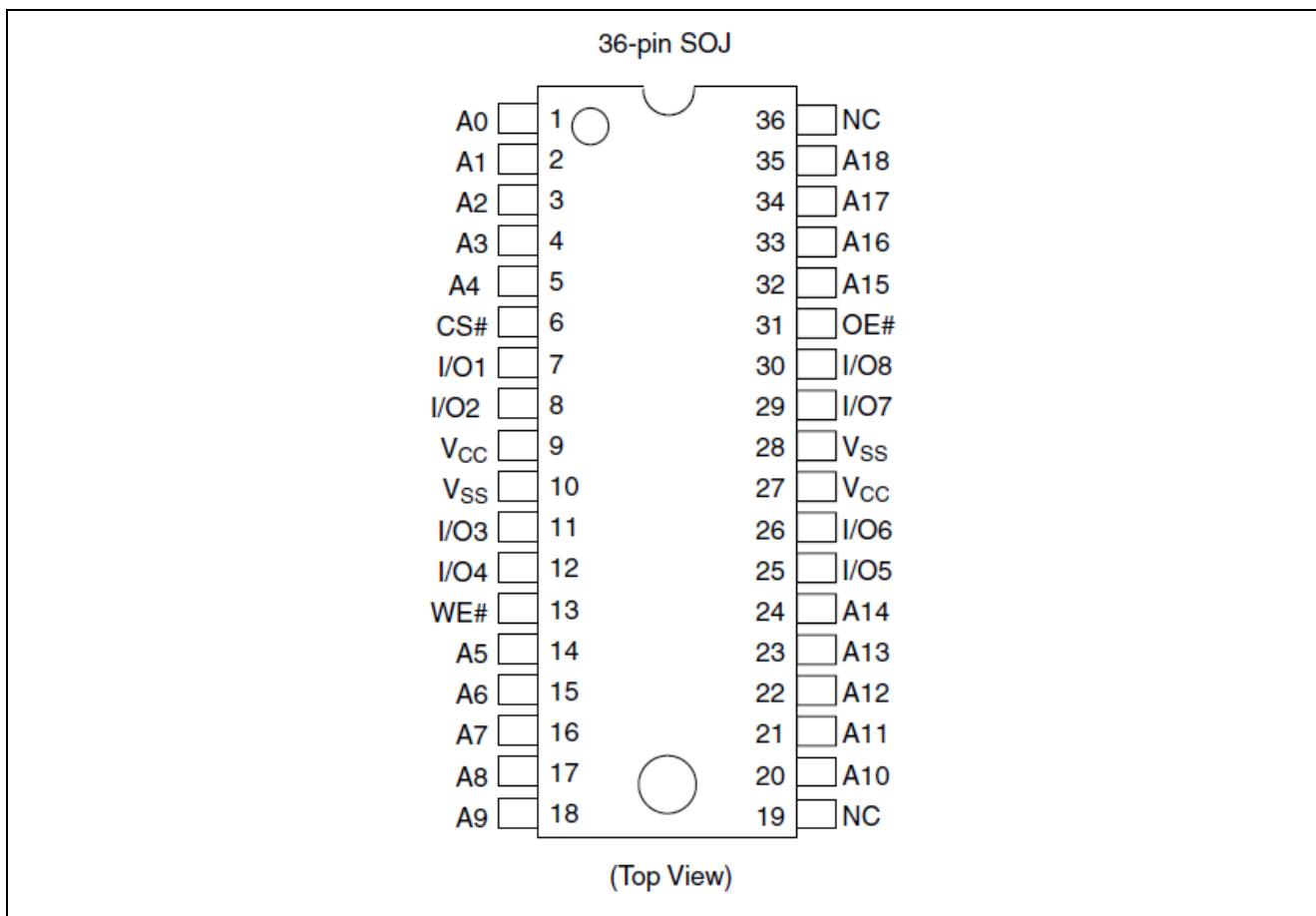

Pin Description

Pin name	Function
A0 to A18	Address input
I/O1 to I/O8	Data input/output
CS#	Chip select
OE#	Output enable
WE#	Write enable
V _{CC}	Power supply
V _{SS}	Ground
NC	No connection

Block Diagram

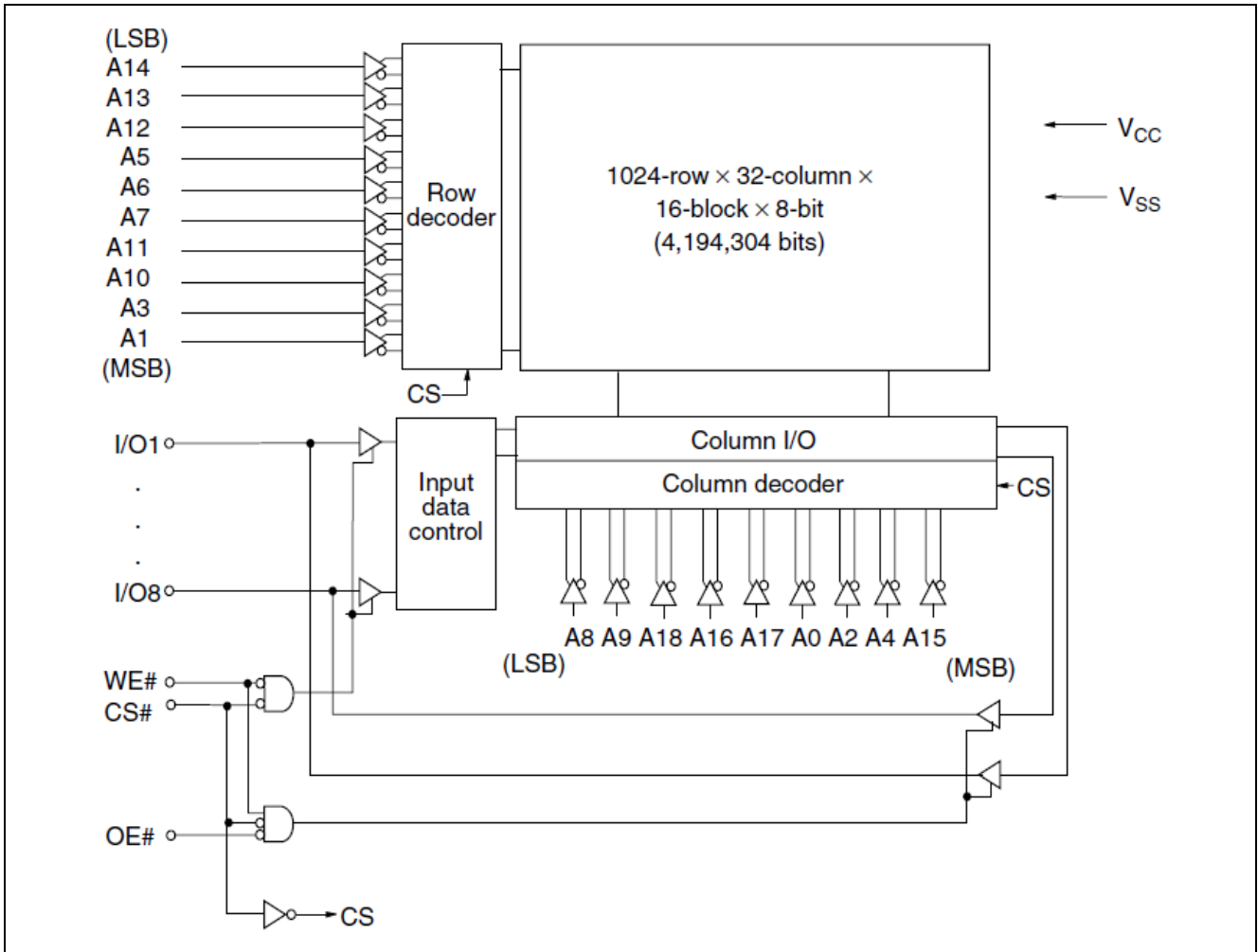

Operation Table

CS#	OE#	WE#	Mode	V _{CC} current	I/O	Ref. cycle
H	×	×	Standby	I _{SB} , I _{SB1}	High-Z	—
L	H	H	Output disable	I _{CC}	High-Z	—
L	L	H	Read	I _{CC}	DOUT	Read cycle (1) to (3)
L	H	L	Write	I _{CC}	DIN	Write cycle (1)
L	L	L	Write	I _{CC}	DIN	Write cycle (2)

Note: H: V_{IH}, L: V_{IL}, ×: V_{IH} or V_{IL}

Absolute Maximum Ratings

Parameter	Symbol	Value	Unit
Supply voltage relative to V _{SS}	V _{CC}	-0.5 to +4.6	V
Voltage on any pin relative to V _{SS}	V _T	-0.5* ¹ to V _{CC} + 0.5* ²	V
Power dissipation	P _T	1.0	W
Operating temperature	T _{opr}	0 to +70	°C
Storage temperature	T _{stg}	-55 to +125	°C
Storage temperature under bias	T _{bias}	-10 to +85	°C

Notes: 1. V_T (min) = -2.0V for pulse width (under shoot) ≤ 6ns.
2. V_T (max) = V_{CC} + 2.0V for pulse width (over shoot) ≤ 6ns.

Recommended DC Operating Conditions

(T_a = 0 to +70°C)

Parameter	Symbol	Min	Typ	Max	Unit
Supply voltage	V _{CC} * ³	3.0	3.3	3.6	V
	V _{SS} * ⁴	0	0	0	V
Input voltage	V _{IH}	2.0	—	V _{CC} + 0.5* ²	V
	V _{IL}	-0.5* ¹	—	0.8	V

Notes: 1. V_{IL} (min) = -2.0V for pulse width (under shoot) ≤ 6ns.
2. V_{IH} (max) = V_{CC} + 2.0V for pulse width (over shoot) ≤ 6ns.
3. The supply voltage with all V_{CC} pins must be on the same level.
4. The supply voltage with all V_{SS} pins must be on the same level.

DC Characteristics(Ta = 0 to +70°C, V_{CC} = 3.3V ± 0.3V, V_{SS} = 0V)

Parameter	Symbol	Min	Max	Unit	Test conditions
Input leakage current	I _{LI}	—	2	μA	V _{IN} = V _{SS} to V _{CC}
Output leakage current	I _{LO}	—	2	μA	V _{IN} = V _{SS} to V _{CC}
Operating power supply current	I _{CC}	—	100	mA	Min cycle CS# = V _{IL} , I _{OUT} = 0mA Other inputs = V _{IH} /V _{IL}
Standby power supply current	I _{SB}	—	40	mA	Min cycle, CS# = V _{IH} , Other inputs = V _{IH} /V _{IL}
	I _{SB1}	—	5	mA	f = 0MHz
		—*1	0.8*1	mA	V _{CC} ≥ CS# ≥ V _{CC} - 0.2V, (1) 0V ≤ V _{IN} ≤ 0.2V or (2) V _{CC} ≥ V _{IN} ≥ V _{CC} - 0.2V
Output voltage	V _{OL}	—	0.4	V	I _{OL} = 8mA
	V _{OH}	2.4	—	V	I _{OH} = -4mA

Note: 1. This characteristics is guaranteed only for L-version.

Capacitance

(Ta = +25°C, f = 1.0MHz)

Parameter	Symbol	Min	Max	Unit	Test conditions
Input capacitance*1	C _{IN}	—	6	pF	V _{IN} = 0V
Input/output capacitance*1	C _{I/O}	—	8	pF	V _{I/O} = 0V

Note: 1. This parameter is sampled and not 100% tested.

AC Characteristics

Test Conditions ($T_a = 0$ to $+70^\circ\text{C}$, $V_{CC} = 3.3\text{V} \pm 0.3\text{V}$, unless otherwise noted.)

- Input pulse levels: 3.0V/0.0V
- Input rise and fall time: 3ns
- Input and output timing reference levels: 1.5V
- Output load: See figures (Including scope and jig)

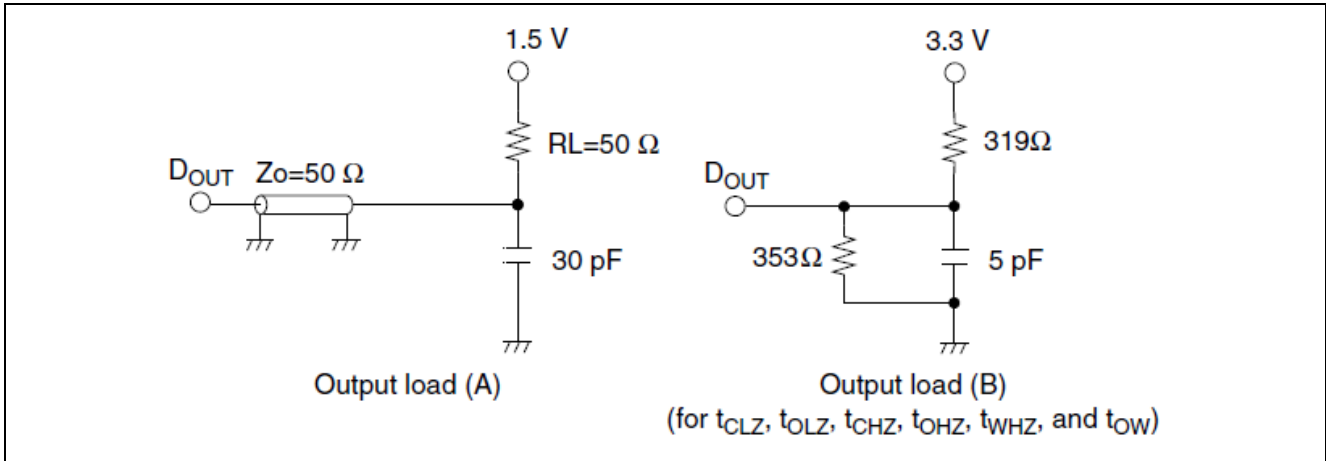

Read Cycle

Parameter	Symbol	R1RW0408D		Unit	Notes
		Min	Max		
Read cycle time	t_{RC}	12	—	ns	
Address access time	t_{AA}	—	12	ns	
Chip select access time	t_{ACS}	—	12	ns	
Output enable to output valid	t_{OE}	—	6	ns	
Output hold from address change	t_{OH}	3	—	ns	
Chip select to output in low-Z	t_{CLZ}	3	—	ns	1
Output enable to output in low-Z	t_{OLZ}	0	—	ns	1
Chip deselect to output in high-Z	t_{CHZ}	—	6	ns	1
Output disable to output in high-Z	t_{OHZ}	—	6	ns	1

Write Cycle

Parameter	Symbol	R1RW0408D		Unit	Notes
		Min	Max		
Write cycle time	t_{WC}	12	—	ns	
Address valid to end of write	t_{AW}	8	—	ns	
Chip select to end of write	t_{CW}	8	—	ns	9
Write pulse width	t_{WP}	8	—	ns	8
Address setup time	t_{AS}	0	—	ns	6
Write recovery time	t_{WR}	0	—	ns	7
Data to write time overlap	t_{DW}	6	—	ns	
Data hold from write time	t_{DH}	0	—	ns	
Write disable to output in low-Z	t_{OW}	3	—	ns	1
Output disable to output in high-Z	t_{OHZ}	—	6	ns	1
Write enable to output in high-Z	t_{WHZ}	—	6	ns	1

Notes: 1. Transition is measured $\pm 200\text{mV}$ from steady voltage with output load (B). This parameter is sampled and not 100% tested.

2. Address should be valid prior to or coincident with CS# transition low.
3. WE# and/or CS# must be high during address transition time.
4. If CS# and OE# are low during this period, I/O pins are in the output state. Then, the data input signals of opposite phase to the outputs must not be applied to them.
5. If the CS# low transition occurs simultaneously with the WE# low transition or after the WE# transition, output remains a high impedance state.
6. t_{AS} is measured from the latest address transition to the later of CS# or WE# going low.
7. t_{WR} is measured from the earlier of CS# or WE# going high to the first address transition.
8. A write occurs during the overlap of a low CS# and a low WE#. A write begins at the latest transition among CS# going low and WE# going low. A write ends at the earliest transition among CS# going high and WE# going high. t_{WP} is measured from the beginning of write to the end of write.
9. t_{CW} is measured from the later of CS# going low to the end of write.

Timing Waveforms

Read Timing Waveform (1) (WE# = V_{IH})

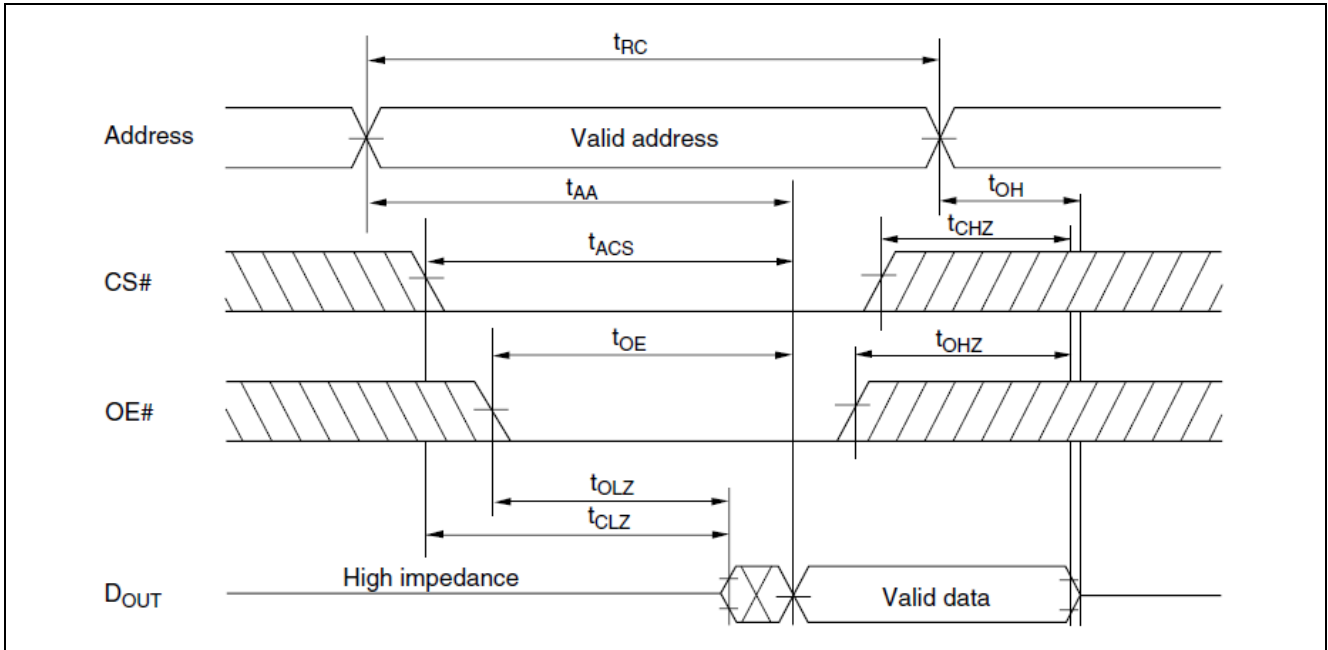

Read Timing Waveform (2) (WE# = V_{IH}, LB# = V_{IL}, UB# = V_{IL})

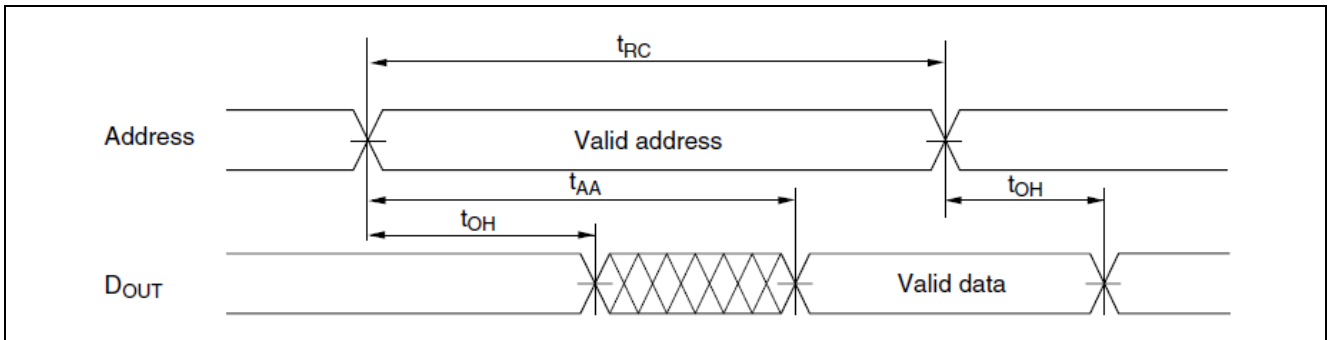

Read Timing Waveform (3) (WE# = V_{IH}, CS# = V_{IL}, OE# = V_{IL})*2

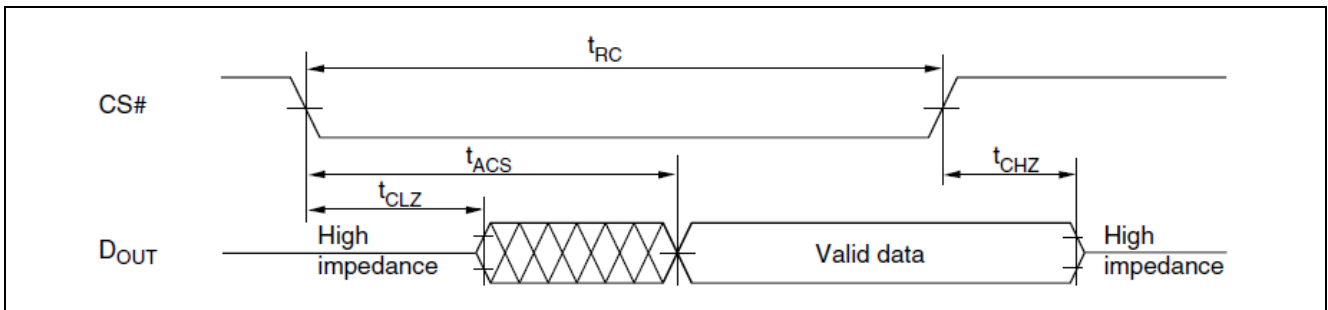

Write Timing Waveform (1) (WE# Controlled)

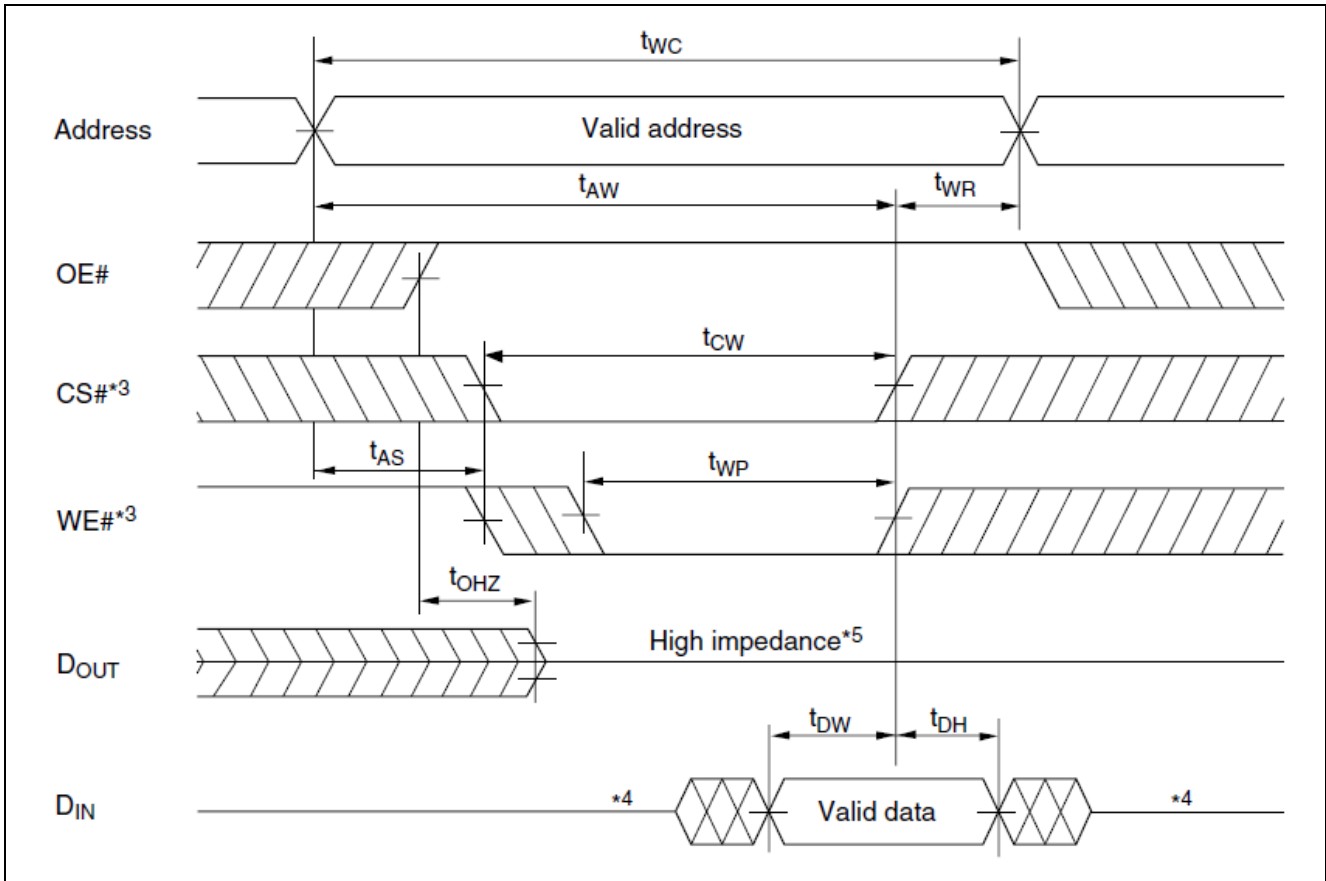

Write Timing Waveform (2) (CS# Controlled)

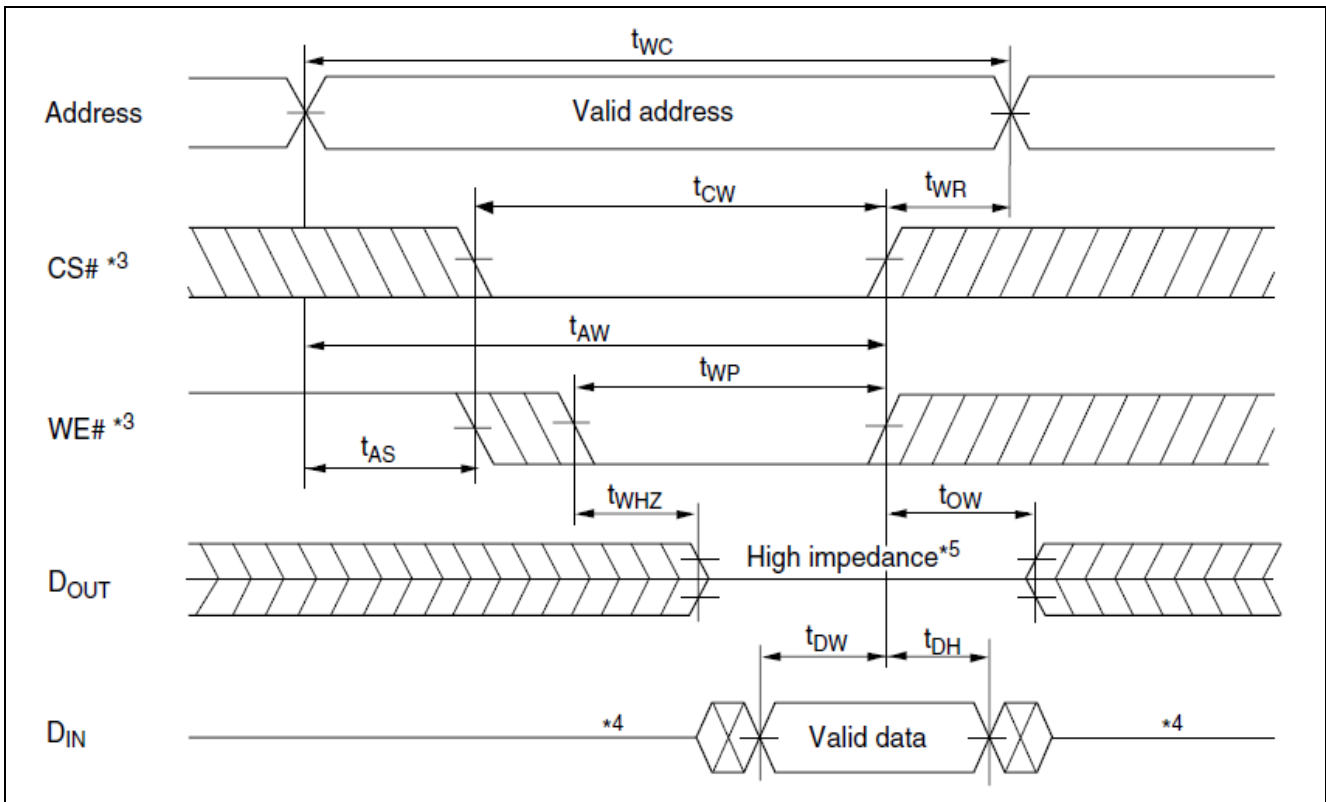

Low V_{CC} Data Retention Characteristics

(T_a = 0 to +70°C)

This characteristics is guaranteed only for L-version.

Parameter	Symbol	Min	Max	Unit	Test conditions
V _{CC} for data retention	V _{DR}	2.0	—	V	V _{CC} ≥ CS# ≥ V _{CC} - 0.2V, (1) 0V ≤ V _{IN} ≤ 0.2V or (2) V _{CC} ≥ V _{IN} ≥ V _{CC} - 0.2V
Data retention current	I _{CCDR}	—	400	μA	V _{CC} = 3V V _{CC} ≥ CS# ≥ V _{CC} - 0.2V, (1) 0V ≤ V _{IN} ≤ 0.2V or (2) V _{CC} ≥ V _{IN} ≥ V _{CC} - 0.2V
Chip deselect to data retention time	t _{CDR}	0	—	ns	See retention waveform
Operation recovery time	t _R	5	—	ms	

Low V_{CC} Data Retention Timing Waveform

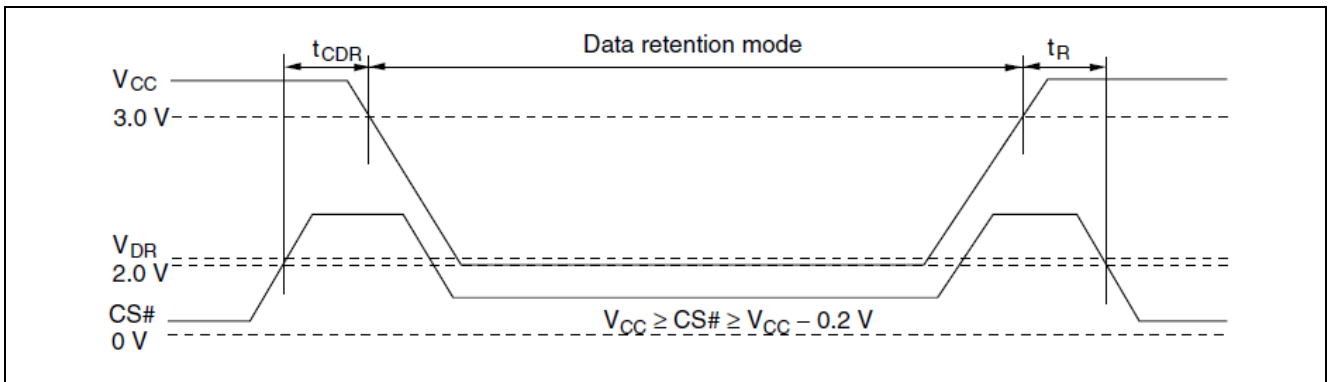

Revision History

Rev.	Date	Description	
		Page	Summary
1.00	Nov.18.19	-	First Edition issued

All documents should contain the following section break and paragraph as the last item. The footers of this document refer to the paragraph in order to reference the last page of the document.

Notice

1. Descriptions of circuits, software and other related information in this document are provided only to illustrate the operation of semiconductor products and application examples. You are fully responsible for the incorporation or any other use of the circuits, software, and information in the design of your product or system. Renesas Electronics disclaims any and all liability for any losses and damages incurred by you or third parties arising from the use of these circuits, software, or information.
2. Renesas Electronics hereby expressly disclaims any warranties against and liability for infringement or any other claims involving patents, copyrights, or other intellectual property rights of third parties, by or arising from the use of Renesas Electronics products or technical information described in this document, including but not limited to, the product data, drawings, charts, programs, algorithms, and application examples.
3. No license, express, implied or otherwise, is granted hereby under any patents, copyrights or other intellectual property rights of Renesas Electronics or others.
4. You shall not alter, modify, copy, or reverse engineer any Renesas Electronics product, whether in whole or in part. Renesas Electronics disclaims any and all liability for any losses or damages incurred by you or third parties arising from such alteration, modification, copying or reverse engineering.
5. Renesas Electronics products are classified according to the following two quality grades: "Standard" and "High Quality". The intended applications for each Renesas Electronics product depends on the product's quality grade, as indicated below.
 - "Standard": Computers; office equipment; communications equipment; test and measurement equipment; audio and visual equipment; home electronic appliances; machine tools; personal electronic equipment; industrial robots; etc.
 - "High Quality": Transportation equipment (automobiles, trains, ships, etc.); traffic control (traffic lights); large-scale communication equipment; key financial terminal systems; safety control equipment; etc.Unless expressly designated as a high reliability product or a product for harsh environments in a Renesas Electronics data sheet or other Renesas Electronics document, Renesas Electronics products are not intended or authorized for use in products or systems that may pose a direct threat to human life or bodily injury (artificial life support devices or systems; surgical implantations; etc.), or may cause serious property damage (space system; undersea repeaters; nuclear power control systems; aircraft control systems; key plant systems; military equipment; etc.). Renesas Electronics disclaims any and all liability for any damages or losses incurred by you or any third parties arising from the use of any Renesas Electronics product that is inconsistent with any Renesas Electronics data sheet, user's manual or other Renesas Electronics document.
6. When using Renesas Electronics products, refer to the latest product information (data sheets, user's manuals, application notes, "General Notes for Handling and Using Semiconductor Devices" in the reliability handbook, etc.), and ensure that usage conditions are within the ranges specified by Renesas Electronics with respect to maximum ratings, operating power supply voltage range, heat dissipation characteristics, installation, etc. Renesas Electronics disclaims any and all liability for any malfunctions, failure or accident arising out of the use of Renesas Electronics products outside of such specified ranges.
7. Although Renesas Electronics endeavors to improve the quality and reliability of Renesas Electronics products, semiconductor products have specific characteristics, such as the occurrence of failure at a certain rate and malfunctions under certain use conditions. Unless designated as a high reliability product or a product for harsh environments in a Renesas Electronics data sheet or other Renesas Electronics document, Renesas Electronics products are not subject to radiation resistance design. You are responsible for implementing safety measures to guard against the possibility of bodily injury, injury or damage caused by fire, and/or danger to the public in the event of a failure or malfunction of Renesas Electronics products, such as safety design for hardware and software, including but not limited to redundancy, fire control and malfunction prevention, appropriate treatment for aging degradation or any other appropriate measures. Because the evaluation of microcomputer software alone is very difficult and impractical, you are responsible for evaluating the safety of the final products or systems manufactured by you.
8. Please contact a Renesas Electronics sales office for details as to environmental matters such as the environmental compatibility of each Renesas Electronics product. You are responsible for carefully and sufficiently investigating applicable laws and regulations that regulate the inclusion or use of controlled substances, including without limitation, the EU RoHS Directive, and using Renesas Electronics products in compliance with all these applicable laws and regulations. Renesas Electronics disclaims any and all liability for damages or losses occurring as a result of your noncompliance with applicable laws and regulations.
9. Renesas Electronics products and technologies shall not be used for or incorporated into any products or systems whose manufacture, use, or sale is prohibited under any applicable domestic or foreign laws or regulations. You shall comply with any applicable export control laws and regulations promulgated and administered by the governments of any countries asserting jurisdiction over the parties or transactions.
10. It is the responsibility of the buyer or distributor of Renesas Electronics products, or any other party who distributes, disposes of, or otherwise sells or transfers the product to a third party, to notify such third party in advance of the contents and conditions set forth in this document.
11. This document shall not be reprinted, reproduced or duplicated in any form, in whole or in part, without prior written consent of Renesas Electronics.
12. Please contact a Renesas Electronics sales office if you have any questions regarding the information contained in this document or Renesas Electronics products.

(Note1) "Renesas Electronics" as used in this document means Renesas Electronics Corporation and also includes its directly or indirectly controlled subsidiaries.

(Note2) "Renesas Electronics product(s)" means any product developed or manufactured by or for Renesas Electronics.

(Rev.4.0-1 November 2017)

Corporate Headquarters

TOYOSU FORESIA, 3-2-24 Toyosu,
Koto-ku, Tokyo 135-0061, Japan
www.renesas.com

Trademarks

Renesas and the Renesas logo are trademarks of Renesas Electronics Corporation. All trademarks and registered trademarks are the property of their respective owners.

Contact information

For further information on a product, technology, the most up-to-date version of a document, or your nearest sales office, please visit:
www.renesas.com/contact/.