

TDS:EMIC

拓電半導體

自主封測 品質把控 售後保障

WEB | WWW.TDSEMIC.COM



電源管理

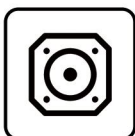

顯示驅動

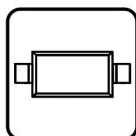

二三極管

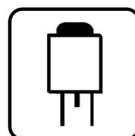

LDO穩壓器

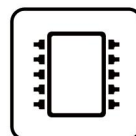

觸摸芯片



MOS管

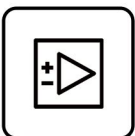

運算放大器

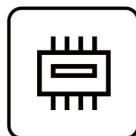

存儲芯片

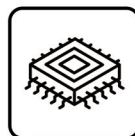

MCU



串口通信

AD8542ARZ-TD

產品規格說明書

PRODUCT DESCRIPTION

The AD8541ARZ(single), AD8542ARZ(dual) and AD8544ARZ(quad) are low voltage micro power CMOS voltage feedback operational amplifiers. With an excellent bandwidth of 1.3MHz, a slew rate of 0.9V/μs, and a quiescent current of 70μA per amplifier at 5V, the AD8542ARZ family can be designed into a wide range of applications. The AD8542ARZop-amps are specifically designed for general-purpose applications with optimal performance. They have a wide input common-mode voltage range and excellent output voltage swings, and the maximum input offset voltage are 2.5mV. These parts provide rail-to-rail output swing into heavy loads. The AD8542ARZfamily is specified for single or dual power supplies of +2.2V to +5.5V. The AD8541ARZis available in 5-lead SC-70 and SOT-23, and 8-lead SOP packages. The AD8542ARZis available in 8-lead MSOP and SOP packages. The AD8544ARZ is available in 14-lead SOP packages.

FEATURES

- Low Offset Voltage: 3.0 mV Maximum
- Gain-Bandwidth Product: 1.2MHz
- High Slew Rate: 1.0 V/μs
- Low Power: 85 μA per Amplifier Supply Current
- Unity Gain Stable
- Rail-to-Rail Input and Output
- Input Voltage Range: -0.2 to +5.2 V at 5V Supply
- Operating Power Supply: +2.2 to +5.5 V
- Operating Temperature Range: -40°C to +125°C
- ESD Rating: HBM – 4kV, CDM – 2kV

APPLICATIONS

- Smoke/Gas/Environment Sensors
- Audio Outputs
- Active Filters
- ASIC Input or Output Amplifier
- Sensor Interfaces
- Portable Equipment
- Battery-Powered Instrumentation

PIN CONFIGURATION

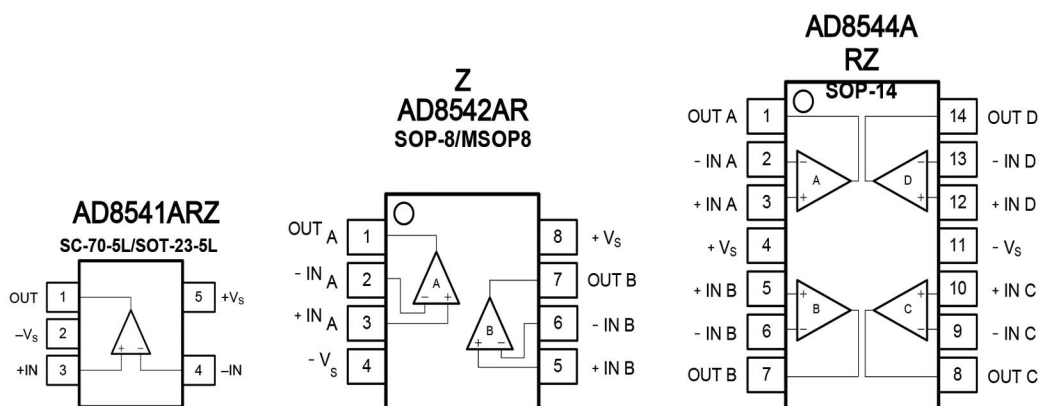

Figure 1. Pin Assignment Diagram

ABSOLUTE MAXIMUM RATINGS

Supply Voltage, +V _S to -V _S	7V
Input Common Mode Voltage Range	(-V _S) - 0.5V to (+V _S) + 0.5V
Storage Temperature Range	-65°C to +150°C
Junction Temperature	+160°C
Lead Temperature (Soldering 10sec).....	+260°C
ESD Susceptibility	
HBM.....	4000V
MM.....	400V
CDM	2000V

RECOMMENDED OPERATING CONDITIONS

Operating Temperature Range -40°C to +125°C

Note: Stress greater than those listed under Absolute Maximum Ratings may cause permanent damage to the device.

This is a stress rating only and functional operation of the device at these or any other conditions outside those indicated in the operational sections of this specification are not implied.

Exposure to absolute maximum rating conditions for extended periods may affect reliability.

ORDERING INFORMATION

Type Number	Package Name	Package Quantity
AD8541ARZARTZ	SOT-23-5L	3000
AD8541ARZAKSZ	SC-70-5L	3000
AD8542ARZARZ	SOP-8L	2500
AD8542ARZARMZ	MSOP-8L	3000
AD8544ARZ	SOP-14L	2500

Electrical Characteristics

V_S = 5.0V, T_A = +25°C, V_{CM} = V_S / 2, V_O = V_S / 2, and R_L = 10kΩ connected to V_S / 2, unless other wise noted. Boldface limits apply over the specified temperature range, T_A = -40 to + 125°C.

Symbol	Parameter	Conditions	Min.	Typ.	Max.	Unit
V _{OS}	Input offset voltage			±1.0	±3.0	mV
V _{OS} T _C	Offset voltage drift	T _A = -40 to +125 °C		±1	3.5	μV/°C
PSRR	Power supply rejection ratio	V _S = 2.2 to 5.5 V, V _{CM} < V _S - 2V	80	110		dB
		T _A = -40 to +125 °C	75			
I _B	Input bias current			5	50	pA
		T _A = +85 °C			200	
		T _A = +125 °C			2000	
I _{OS}	Input offset current			10	50	pA
V _n	Input voltage noise	f = 0.1 to 10 Hz		6		μV _{P-P}
e _n	Input voltage noise density	f = 10 kHz		27		nV/√Hz
		f = 1 kHz		30		
I _n	Input current noise density	f = 1 kHz		5		fA/√Hz

Electrical Characteristics

$V_S = 5.0V$, $T_A = +25^\circ C$, $V_{CM} = V_S / 2$, $V_O = V_S / 2$, and $R_L = 10k\Omega$ connected to $V_S / 2$, unless other wise noted.
Boldface limits apply over the specified temperature range, $T_A = -40$ to $+125^\circ C$.

Symbol	Parameter	Conditions	Min.	Typ.	Max.	Unit
V_{CM}	Common-mode voltage range		$V_S - 0.1$		$V_S + 0.1$	V
CMRR	Common-mode rejection ratio	$V_S = 5.5V, V_{CM} = -0.1$ to $5.6V$	70	83		dB
		$V_{CM} = 0$ to $5.3V, T_A = -40$ to $+125^\circ C$	65			
		$V_S = 2.2V, V_{CM} = -0.1$ to $2.2V$	65	77		
		$V_{CM} = 0$ to $2.2V, T_A = -40$ to $+125^\circ C$	60			
C_{IN}	Input capacitance	Differential		2.0		pF
		Common mode		3.5		
A_{VOL}	Open-loop voltage gain	$R_L = 25k\Omega, V_O = 0.05$ to $3.5V$	90	105		dB
		$T_A = -40$ to $+125^\circ C$	85			
		$R_L = 2k\Omega, V_O = 0.15$ to $3.5V$	85	100		
		$T_A = -40$ to $+125^\circ C$	80			
GBW	Gainbandwidth product			1.2		MHz
SR	Slew rate	$G = +1, C_L = 100pF, V_O = 1.5$ to $3.5V$		1.0		V/ μs
THD+N	Total harmonic distortion + noise	$G = +1, f = 1kHz, V_O = 1V_{RMS}$		0.003		%
t_s	Settling time	To 0.1%, $G = +1, 1V$ step		1.5		μs
		To 0.01%, $G = +1, 1V$ step		1.8		
t_{OR}	Overload recovery time	To 0.1%, $V_{IN}^* \text{ Gain} > V_S$		2.5		μs
V_{OH}	High output voltage swing	$R_L = 50k\Omega$	$V_{S+} - 6$	$V_{S+} - 3$		mV
		$R_L = 2k\Omega$	$V_{S+} - 100$	$V_{S+} - 65$		
V_{OL}	Low output voltage swing	$R_L = 50k\Omega$		$V_{S-} + 2$	$V_{S-} + 4$	mV
		$R_L = 2k\Omega$		$V_{S-} + 43$	$V_{S-} + 65$	
I_{SC}	Short-circuit current	Source current through 10Ω		40		mA
		Sink current through 10Ω		50		
V_S	Operating supply voltage		2.2		5.5	V
I_Q	Quiescent current (per amplifier)			85	120	μA
		$T_A = -40$ to $+125^\circ C$			150	
T_A	Operating temperature range		-40		+125	$^\circ C$

TYPICAL PERFORMANCE CHARACTERISTICS

At $T_A = +25^\circ\text{C}$, $V_{CM} = V_S/2$, and $R_L = 10\text{k}\Omega$ connected to $V_S/2$, unless otherwise noted.

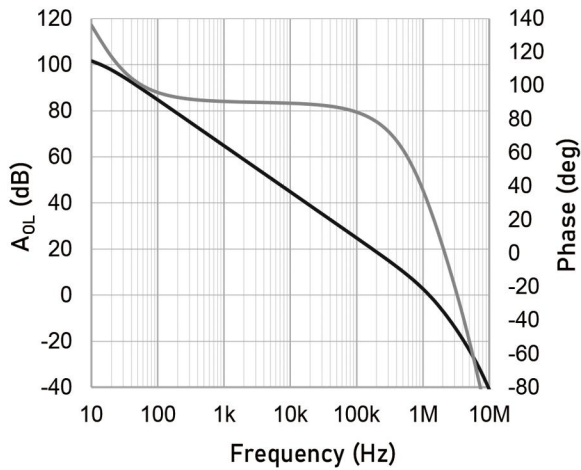

Open-loop Gain and Phase as a function of Frequency.

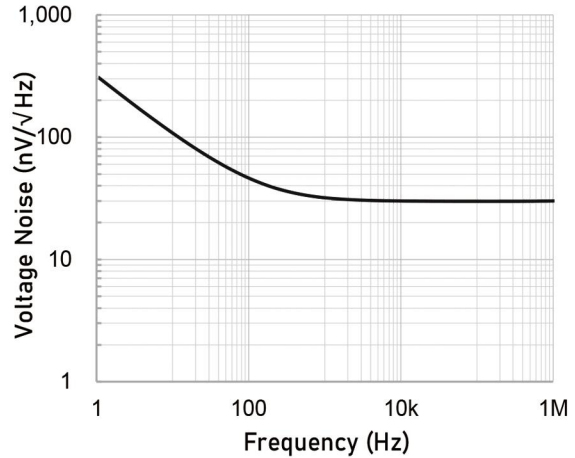

Input Voltage Noise Spectral Density as a function of Frequency.

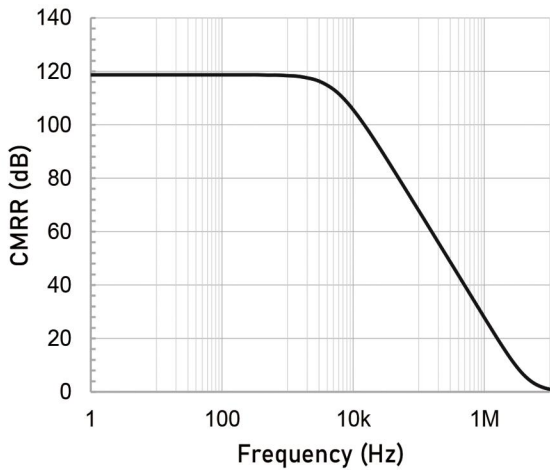

Common-mode Rejection Ratio as a function of Frequency.

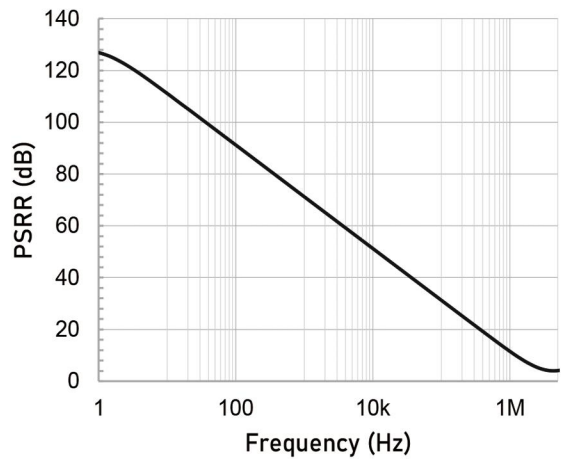

Power Supply Rejection Ratio as a function of Frequency.

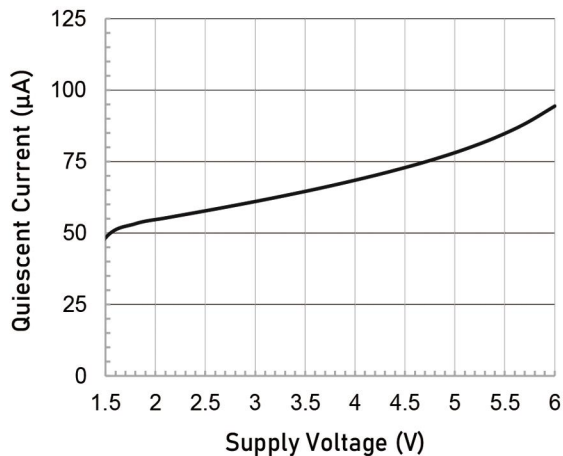

Quiescent Current as a function of Supply Voltage.

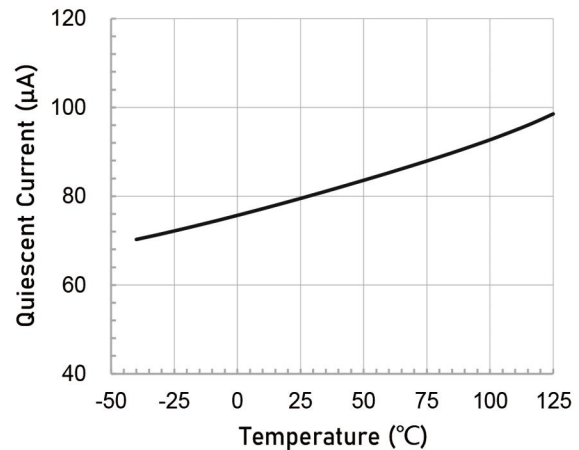

Quiescent Current as a function of Temperature.

TYPICAL PERFORMANCE CHARACTERISTICS

At $T_A = +25^\circ\text{C}$, $V_{CM} = V_S/2$, and $R_L = 10\text{k}\Omega$ connected to $V_S/2$, unless otherwise noted.

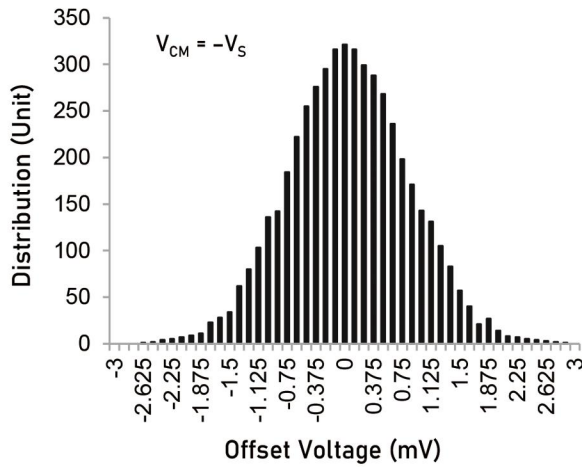

Offset Voltage Production Distribution

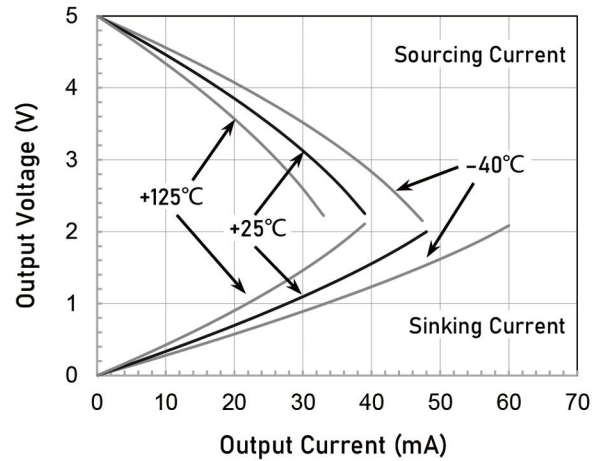

Output Voltage Swing as a function of Output Current.

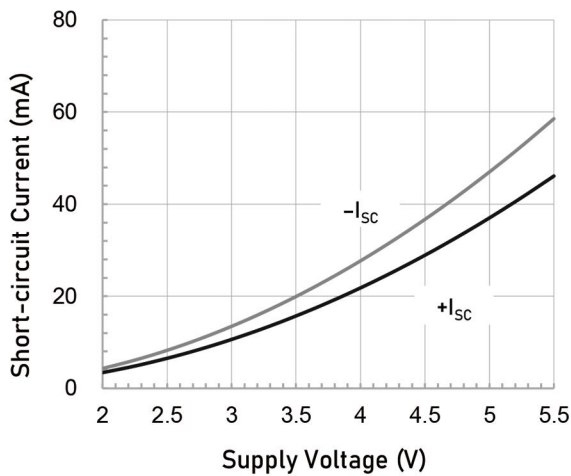

Short-circuit Current as a function of Supply Voltage.

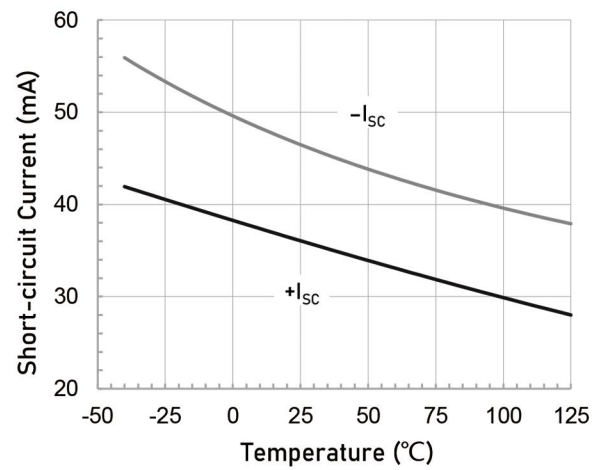

Short-circuit Current as a function of Temperature.

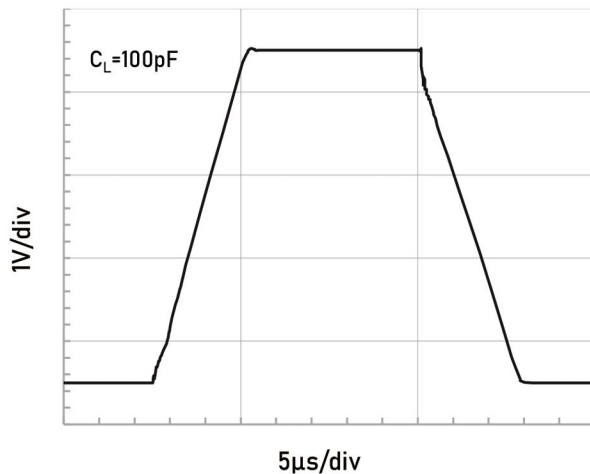

Large Signal Step Response.

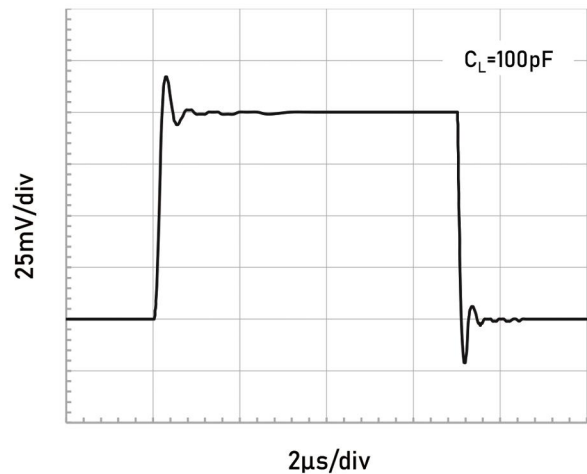

Small Signal Step Response.

APPLICATION NOTE

Size

AD8542ARZ family series op amps are unity-gain stable and suitable for a wide range of general-purpose applications. The small footprints of the AD8542ARZ family packages save space on printed circuit boards and enable the design of smaller electronic products.

Power Supply Bypassing and Board Layout

AD8542ARZ family series operates from a single 2.2V to 5.5V supply or dual $\pm 1.0V$ to $\pm 3V$ supplies. For best performance, a $0.1\mu F$ ceramic capacitor should be placed close to the V_{DD} pin in single supply operation. For dual supply operation, both V_{DD} and V_{SS} supplies should be bypassed to ground with separate $0.1\mu F$ ceramic capacitors.

Low Supply Current

The low supply current (typical $85\mu A$ per channel) of AD8542ARZ family will help to maximize battery life. They are ideal for battery powered systems.

Operating Voltage

AD8542ARZ family operates under wide input supply voltage (2.2V to 5.5V). In addition, all temperature specifications apply from $-40^{\circ}C$ to $+125^{\circ}C$. Most behavior remains unchanged throughout the full operating voltage range. These guarantees ensure operation throughout the single Li-Ion battery lifetime.

Rail-to-Rail Input

The input common-mode range of AD8542ARZ family extends $100mV$ beyond the supply rails ($V_{SS}-0.1V$ to $V_{DD}+0.1V$).

This is achieved by using complementary input stage. For normal operation, inputs should be limited to this range.

Rail-to-Rail Output

Rail-to-Rail output swing provides maximum possible dynamic range at the output. This is particularly important when operating in low supply voltages. The output voltage of AD8542ARZ family can typically swing to less than $10mV$ from supply rail in light resistive loads ($>100k\Omega$), and $60mV$ of supply rail in moderate resistive loads ($10k\Omega$).

Capacitive Load Tolerance

The AD8542ARZ family is optimized for bandwidth and speed, not for driving capacitive loads. Output capacitance will create a pole in the amplifier's feedback path, leading to excessive peaking and potential oscillation. If dealing with load capacitance is a requirement of the application, the two strategies to consider are (1) using a small resistor in series with the amplifier's output and the load capacitance and (2) reducing the bandwidth of the amplifier's feedback loop by increasing the overall noise gain. Figure 2 shows a unity gain follower using the series resistor strategy. The resistor isolates the output from the capacitance and, more importantly, creates a zero in the feedback path that compensates for the pole created by the output capacitance.

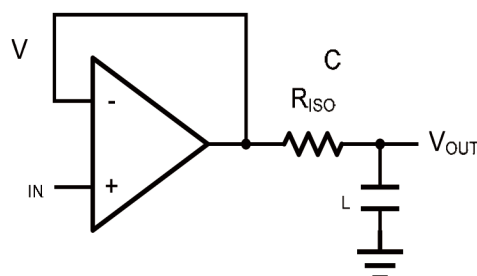

Figure 2 Indirectly Driving a Capacitive Load Using Isolation Resistor

The bigger the R_{ISO} resistor value, the more stable V_{OUT} will be. However, if there is a resistive load R_L in parallel with the capacitive load, a voltage divider (proportional to R_{ISO}/R_L) is formed, this will result in a gain error.

The circuit in Figure 3 is an improvement to the one in Figure 2. R_F provides the DC accuracy by feed-forward the V_{IN} to R_L . C_F and R_{ISO} serve to counteract the loss of phase margin by feeding the high frequency component of the output signal back to the amplifier's inverting input, thereby preserving the phase margin in the overall feedback loop. Capacitive drive can be increased by increasing the value of C_F . This in turn will slow down the pulse response.

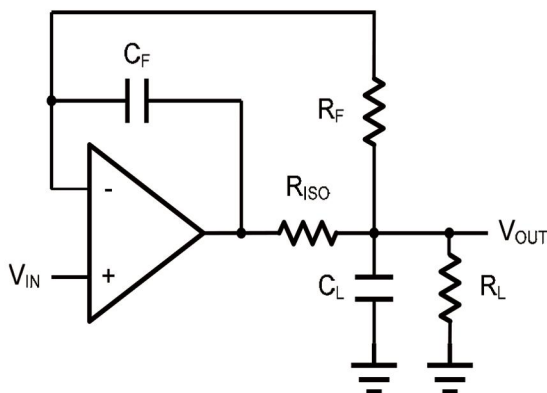

Figure 3. Indirectly Driving a Capacitive Load with DC Accuracy

INSTRUMENTATION AMPLIFIER

The triple AD8542ARZ family can be used to build a three-op-amp instrumentation amplifier as shown in Figure 4. The amplifier in Figure 4 is a high input impedance differential amplifier with gain of R_2/R_1 . The two differential voltage followers assure the high input impedance of the amplifier.

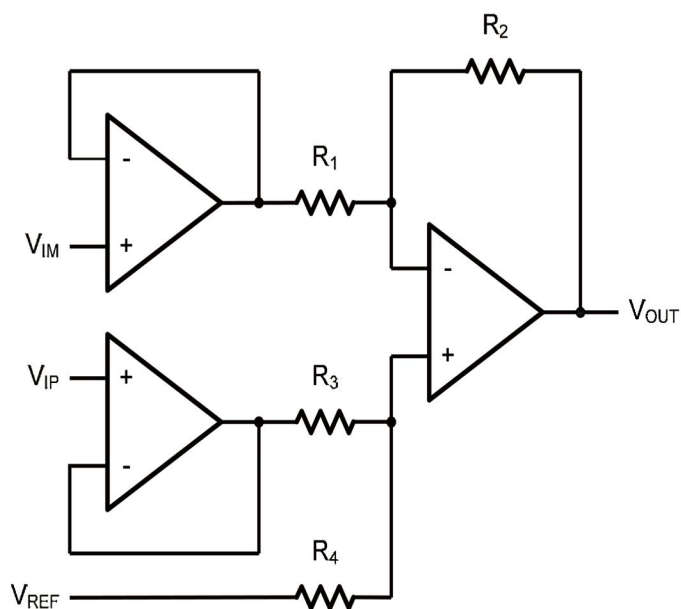

Figure 4. Instrument Amplifier

TYPICAL APPLICATION CIRCUITS

Differential amplifier

The differential amplifier allows the subtraction of two input voltages or cancellation of a signal common the two inputs.

It is useful as a computational amplifier in making a differential to single-end conversion or in rejecting a common mode signal. Figure 5. shown the differential amplifier using AD8542ARZ family.

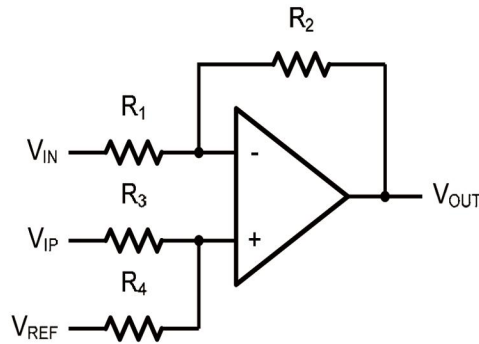

Figure 5. Differential Amplifier

$$V_{OUT} = \left(\frac{R_1+R_2}{R_3+R_4}\right) \frac{R_4}{R_1} V_{IN} - \frac{R_2}{R_1} V_{IP} + \left(\frac{R_1+R_2}{R_3+R_4}\right) \frac{R_3}{R_1} V_{REF}$$

If the resistor ratios are equal (i.e. $R_1=R_3$ and $R_2=R_4$), then

$$V_{OUT} = \frac{R_2}{R_1} (V_{IP} - V_{IN}) + V_{REF}$$

Low Pass Active Filter

The low pass active filter is shown in Figure 6. The DC gain is defined by $-R_2/R_1$. The filter has a -20dB/decade roll-off after its corner frequency $f_c=1/(2\pi R_3 C_1)$.

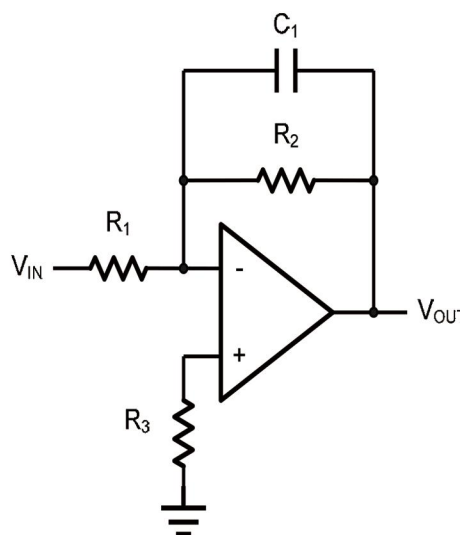
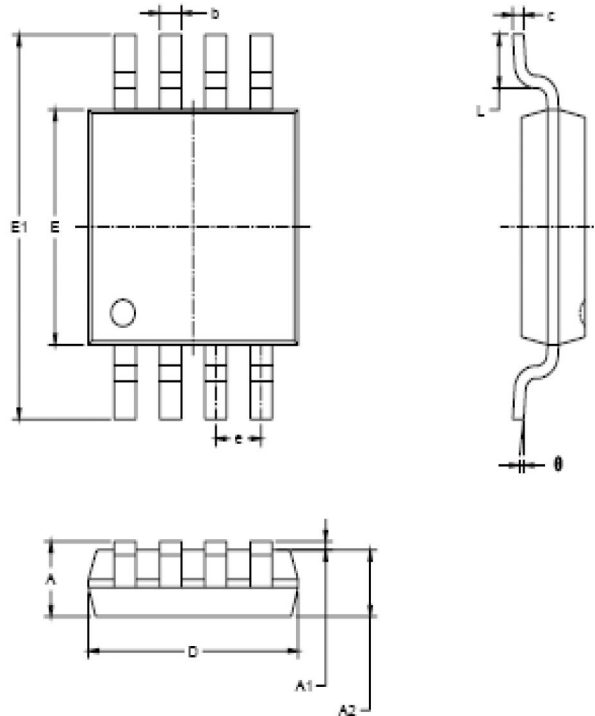

Figure 6. Low Pass Active Filter

PACKAGE OUTLINE DIMENSIONS MSOP-8



Symbol	Dimensions In Millimeters		Dimensions In Inches	
	MIN	MAX	MIN	MAX
A	0.820	1.100	0.032	0.043
A1	0.020	0.150	0.001	0.006
A2	0.750	0.950	0.030	0.037
b	0.250	0.380	0.010	0.015
e	0.090	0.230	0.004	0.009
D	2.900	3.100	0.114	0.122
E	2.900	3.100	0.114	0.122
E1	4.750	5.050	0.187	0.199
e	0.650 BSC		0.026 BSC	
L	0.400	0.800	0.016	0.031
θ	0°	6°	0°	6°

SOP-8

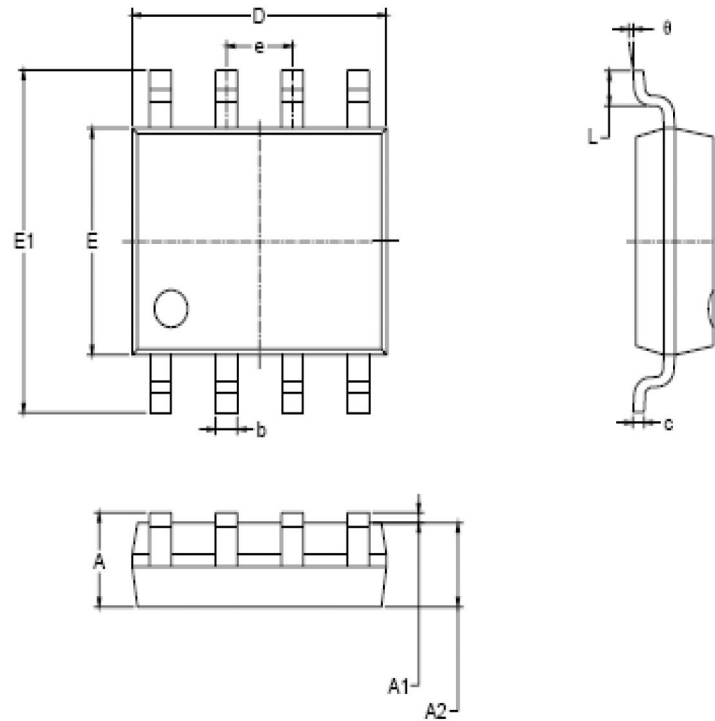

Symbol	Dimensions In Millimeters		Dimensions In Inches	
	MIN	MAX	MIN	MAX
A	1.350	1.750	0.053	0.069
A1	0.100	0.250	0.004	0.010
A2	1.350	1.550	0.053	0.061
b	0.330	0.510	0.013	0.020
c	0.170	0.250	0.006	0.010
D	4.700	5.100	0.185	0.200
E	3.800	4.000	0.150	0.157
E1	5.800	6.200	0.228	0.244
e	1.27 BSC		0.050 BSC	
L	0.400	1.270	0.016	0.050
theta	0°	8°	0°	8°

SOT-23-5L

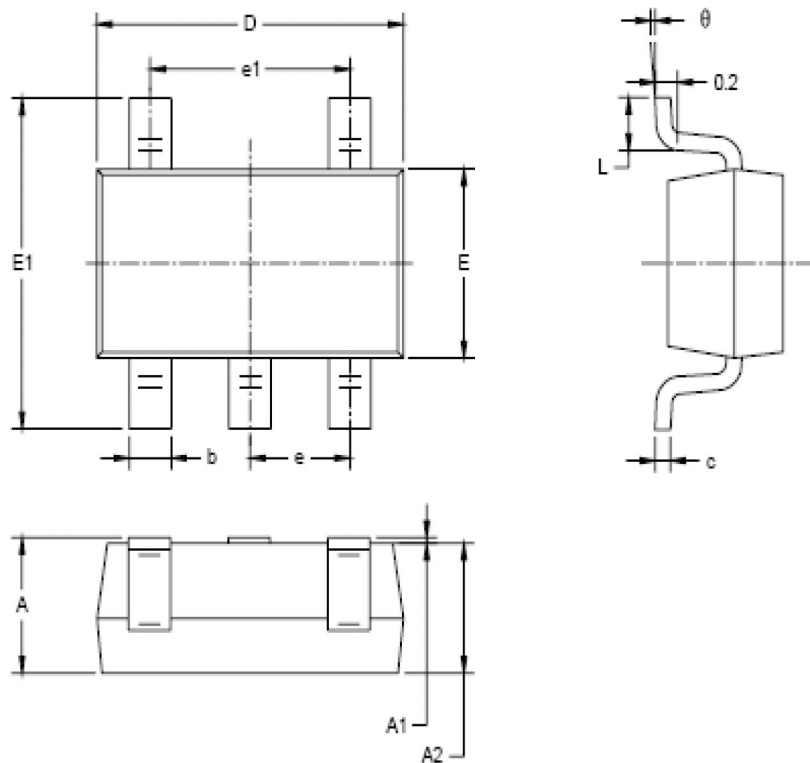

Symbol	Dimensions In Millimeters		Dimensions In Inches	
	MIN	MAX	MIN	MAX
A	1.050	1.250	0.041	0.049
A1	0.000	0.100	0.000	0.004
A2	1.050	1.150	0.041	0.045
b	0.300	0.500	0.012	0.020
c	0.100	0.200	0.004	0.008
D	2.820	3.020	0.111	0.119
E	1.500	1.700	0.059	0.067
E1	2.650	2.950	0.104	0.116
e	0.950 BSC		0.037 BSC	
e1	1.900 BSC		0.075 BSC	
L	0.300	0.600	0.012	0.024
θ	0°	8°	0°	8°

SC-70-5L

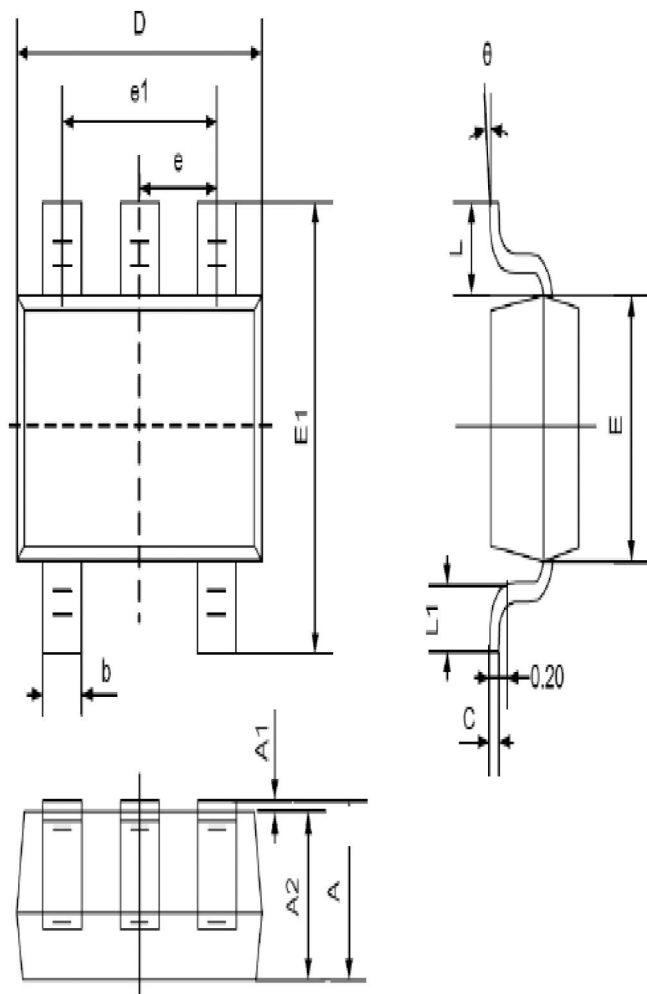

Symbol	Dimensions In Millimeters		Dimensions In Inches	
	Min	Max	Min	Max
A	0.900	1.100	0.035	0.043
A1	0.000	0.100	0.000	0.004
A2	0.900	1.000	0.035	0.039
b	0.150	0.350	0.006	0.014
C	0.080	0.150	0.003	0.006
D	2.000	2.200	0.079	0.087
E	1.150	1.350	0.045	0.053
E1	2.150	2.450	0.085	0.096
e	0.650TYP		0.026TYP	
e1	1.200	1.400	0.047	0.055
L	0.525REF		0.021REF	
L1	0.260	0.460	0.010	0.018
θ	0°	8°	0°	8°

SOP-14

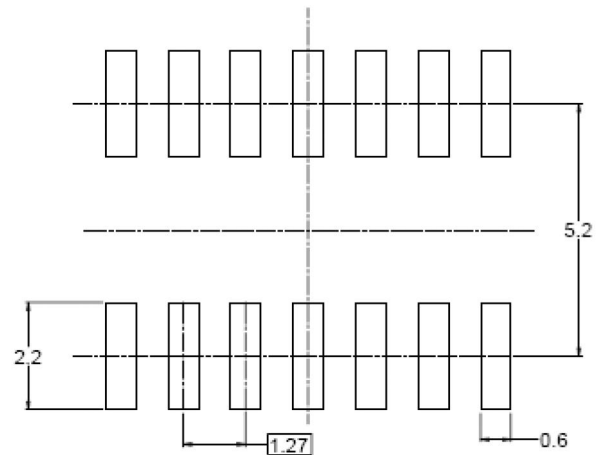
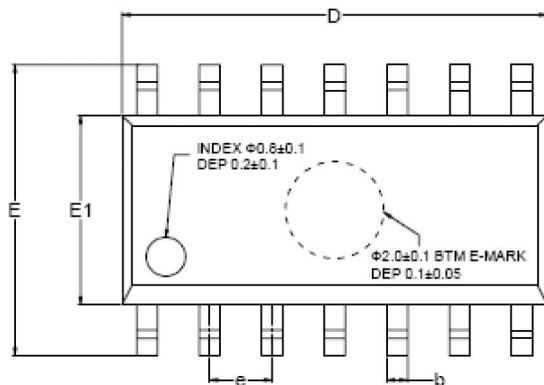

RECOMMENDED LAND PATTERN (Unit: mm)

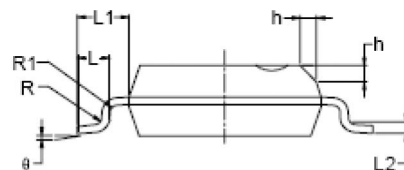
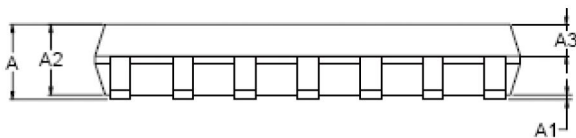

Symbol	Dimensions In Millimeters			Dimensions In Inches		
	MIN	MOD	MAX	MIN	MOD	MAX
A	1.35		1.75	0.053		0.069
A1	0.10		0.25	0.004		0.010
A2	1.25		1.65	0.049		0.065
A3	0.55		0.75	0.022		0.030
b	0.36		0.49	0.014		0.019
D	8.53		8.73	0.336		0.344
E	5.80		6.20	0.228		0.244
E1	3.80		4.00	0.150		0.157
e	1.27 BSC			0.050 BSC		
L	0.45		0.80	0.018		0.032
L1	1.04 REF			0.040 REF		
L2	0.25 BSC			0.01 BSC		
R	0.07			0.003		
R1	0.07			0.003		
h	0.30		0.50	0.012		0.020
θ	0°		8°	0°		8°