



# SPECIFICATION

## Surface Acoustic Wave Filter

USER



USER PART No.

SEMCO PART No. **SFWG00LB002**

DOC. No. SMS-51-L-SFT FW-51

DATE Jan 24, 2014

REVISION Preliminary

WISOL					
ISSUED BY	Kim, Kyung-Sik 	APPROVED BY (R&D)	Hong, Seong-Su 	APPROVED BY (QC)	Choi. Jae hyeong 
User					
ISSUED BY		CHECKED BY		APPROVED BY	

WISOL CO., LTD.  
531-7, Gajang-ro, Osan-si,  
Gyeonggi-do, KOREA, 447-210  
<http://www.wisol.co.kr>

▶ A TABLE OF CONTENTS

1. REVISION HISTORY .....	3
2. DEFINITION .....	4
3. PRECAUTIONS .....	4
4. OUTLINE DRAWING & DIMENSIONS .....	5
5. MARKING .....	6
6. PERFORMANCE .....	7
6-1. MAXIMUM RATINGS .....	7
6-2. ELECTRICAL CHARACTERISTICS .....	8
7. RELIABILITY .....	12
7-1. ENGINEERING SAMPLE FLOW CHART .....	12
7-2. TEST ITEM & CONDITION .....	13
8. REFLOW CONDITION .....	14
9. RECOMMENDED PCB DIMENSIONS .....	14
10. CAUTION .....	15
11. PACKING .....	16
11-1. DIMENSIONS .....	16
11-2. REELING QUANTITY .....	17
11-3. TAPING STRUCTURE .....	17
11-4. INNER BOX(Reel Packing) STRUCTURE .....	18
11-5. OUTER BOX STRUCTURE .....	19
12. TAPE SPECIFICATIONS .....	20
13. RoHS DATA .....	21

## 1. REVISION HISTORY

Preliminary	Jan 24, 2014	All Page	Make specification
-------------	--------------	----------	--------------------

## 2. DEFINITION

### 2-1. PART No.

**SFWG00LB002**

①      ②      ③      ④      ⑤      ⑥

No.	EXPLANATION	
①	SAW Filter	
②	Design Type	
③	Center Frequency Filter1	1900.0MHz (1800~1920MHz)
④	Balanced Filter	Input: Unbalanced 50 ohm Output: Balanced 100 ohm//6.8nH
⑤	Package size: 1.5×1.1mm <sup>2</sup>	
⑥	Design Revision (02 : Molding Type)	

### 2-2. APPLICATION: TDSCDMA B39 + B34 Dual

## 3. PRECAUTIONS

3-1. This device should not be used in any type of fluid such as water, oil, organic solvent, etc.

3-2. This is a hermetic device.

MSL(Moisture Sensitive Level) is the '2a' level.

3-3. Ultrasonic cleaning shall be avoided.

3-4. Isopropyl Alcohol and Ethyl Alcohol can be used for cleaning. Contact us before using other cleaning solvents than above

3-5. This is an electrostatic sensitive device.

Please avoid static voltage during operation and storage.

3-6. Sudden change of temperature shall be avoided, deterioration of the characteristics can occur.

3-7. If any malfunction due to designing or manufacturing which is out of specification occurs within one year after the products have been delivered, the maker should exchange the defective products.

4. OUTLINE DRAWING & DIMENSIONS

[Unit: mm]

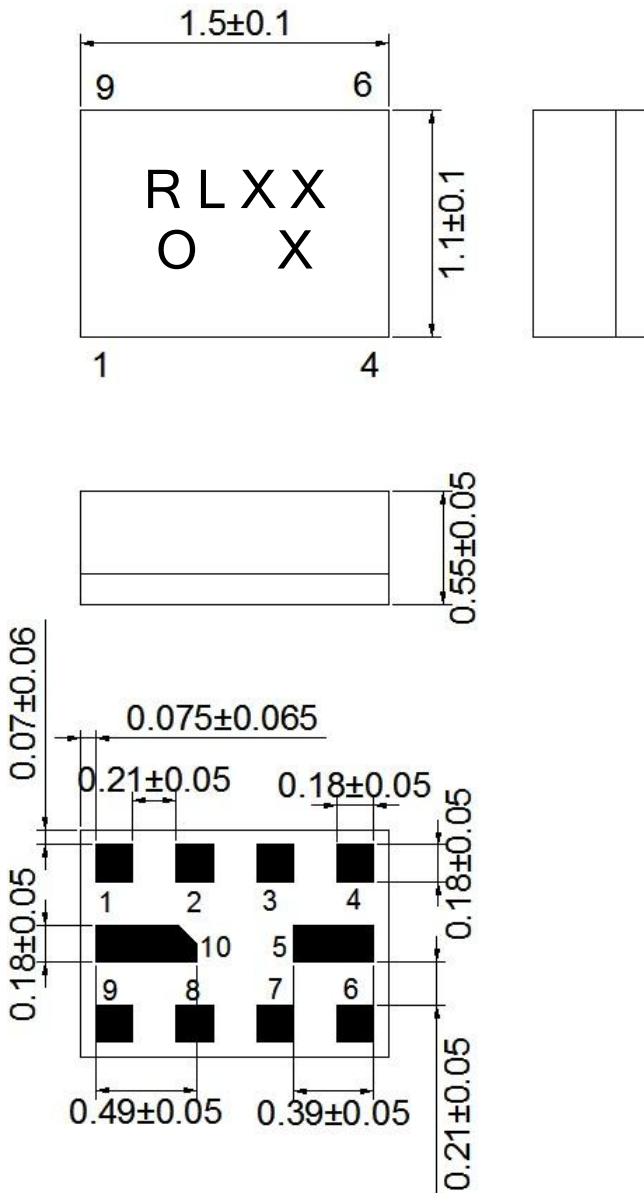

No.	Function
1	B39 Unbalanced Input
4	B34 Unbalanced Input
6,9	B39 & B34 Balanced Output
2, 3, 5, 7, 8, 10	GND

5. MARKING



5-1. R L X X X

- The 1<sup>st</sup> 2<sup>nd</sup> character 'RL' indicates the model name of SAW Filter SFWG00LB002.
- The 3<sup>rd</sup> character 'X' indicates the year and the month of manufacture.

Year	Month											
	1	2	3	4	5	6	7	8	9	10	11	12
2013	P	Q	R	S	T	U	V	W	X	Y	Z	a
2014	1	2	3	4	5	6	7	8	9	A	B	C
2015	D	E	F	G	H	I	J	K	L	M	N	O
2016	P	Q	R	S	T	U	V	W	X	Y	Z	a

※ This rotates by the 3 years.

- The 4<sup>th</sup>, 5<sup>th</sup> character 'X' indicates Lot No.

5-2. O

- This symbol indicates input pin 1.
- This indicates the producing center
  - : China,

5-3. Marking: Laser Marking

## 6. PERFORMANCE

### 6-1. MAXIMUM RATINGS

CHARACTERISTICS	RATINGS	UNITS
DC Permissive Voltage	5	V
Maximum Input Power	15	dBm
Operating Temperature Range	- 30 ~ +85	°C
Storage Temperature Range	- 40 ~ +85	°C

**6-2. ELECTRICAL CHARACTERISTICS**  
**6-2-1. TABLE**

Ta = - 30 ~ +85℃

ITEM	UNIT	LTE B39				LTE B34			
		Freq. Range [MHz]	Min.	Typ. (25℃)	Max.	Freq. Range [MHz]	Min.	Typ. (25℃)	Max.
Insertion Loss	dB	1880 ~ 1920	-	1.9	2.7	2010 ~ 2025	-	2.2	3.0
Inband Ripple	dB	1880 ~ 1920	-	0.4	1.3	2010 ~ 2025	-	0.2	1.1
Input VSWR	-	1880 ~ 1920	-	1.4	2.0	2010 ~ 2025	-	1.4	2.0
Output VSWR	-	1880 ~ 1920	-	1.3	2.0	2010 ~ 2025	-	1.3	2.0
Amplitude Imbalance	dB	1880 ~ 1920	-2.0	-	-2.0	2010 ~ 2025	-2.0	-	-2.0
Phase Imbalance	degree	1880 ~ 1920	-20	-	+20	2010 ~ 2025	-20	-	+20
Absolute Attenuation	dB	DC ~ 915	50	64	-	DC ~ 1805	35	41	-
	dB	915 ~ 1710	30	37	-	1805 ~ 1850	35	40	-
	dB	1710 ~ 1785	20	25	-	1850 ~ 1895	32	37	-
	dB	1785 ~ 1850	8	16	-	1925 ~ 1980	7	13	-
	dB	1950 ~ 2010	8	20	-	2050 ~ 2110	3	9	-
	dB	2010 ~ 2025	28	34	-	2110 ~ 2170	23	28	-
	dB	2025 ~ 2400	23	28	-	2170 ~ 2400	26	31	-
	dB	2400 ~ 2500	35	42	-	2400 ~ 2500	35	40	-
	dB	2500 ~ 6000	25	29	-	2500 ~ 6000	30	37	-
Termination Impedance		Input: Unbalanced 50 ohm Output: Balanced 100 ohm // 6.8nH				Input: Unbalanced 50 ohm Output: Balanced 100 ohm // 6.8nH			



6-2-2. TEST FIXTURE

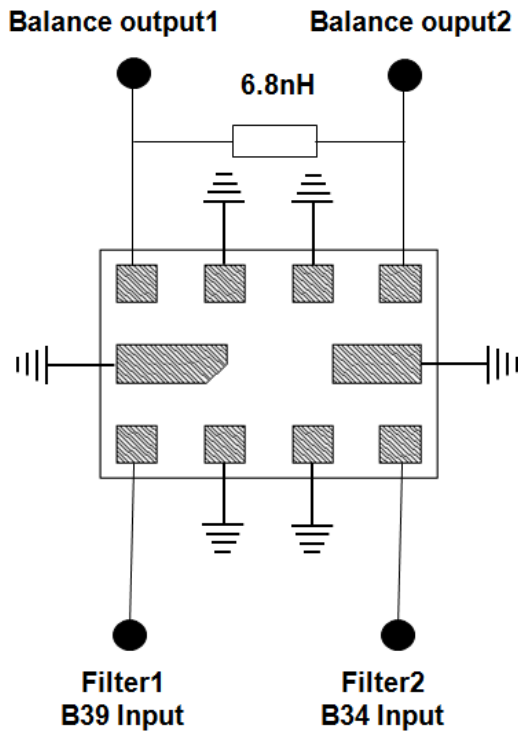

< X-ray Top View >

6-2-3. GRAPH

LTE B39

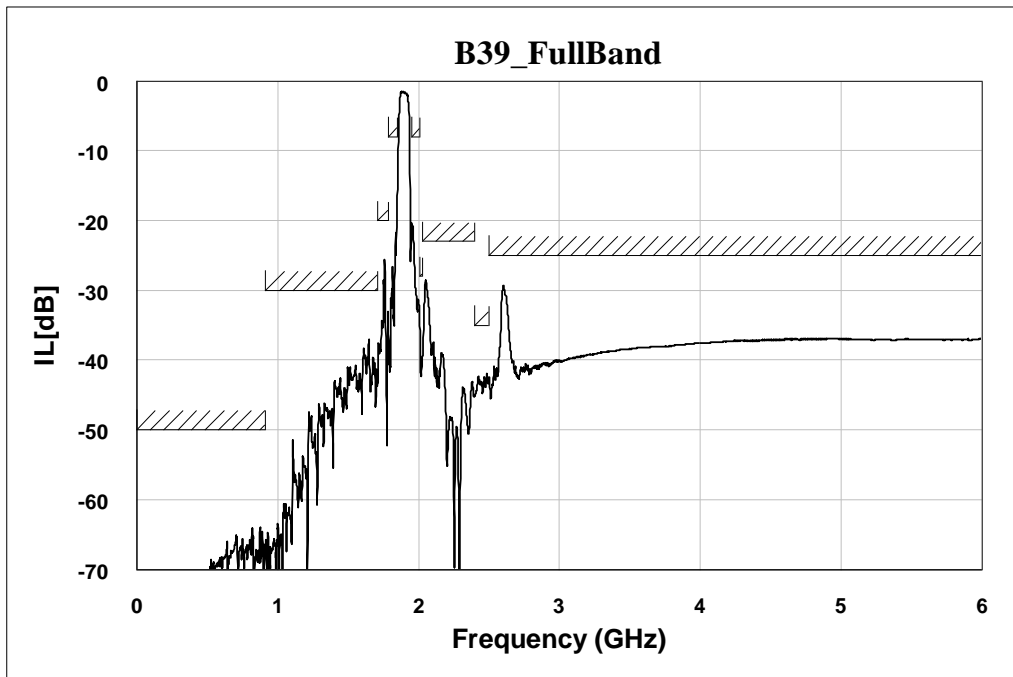
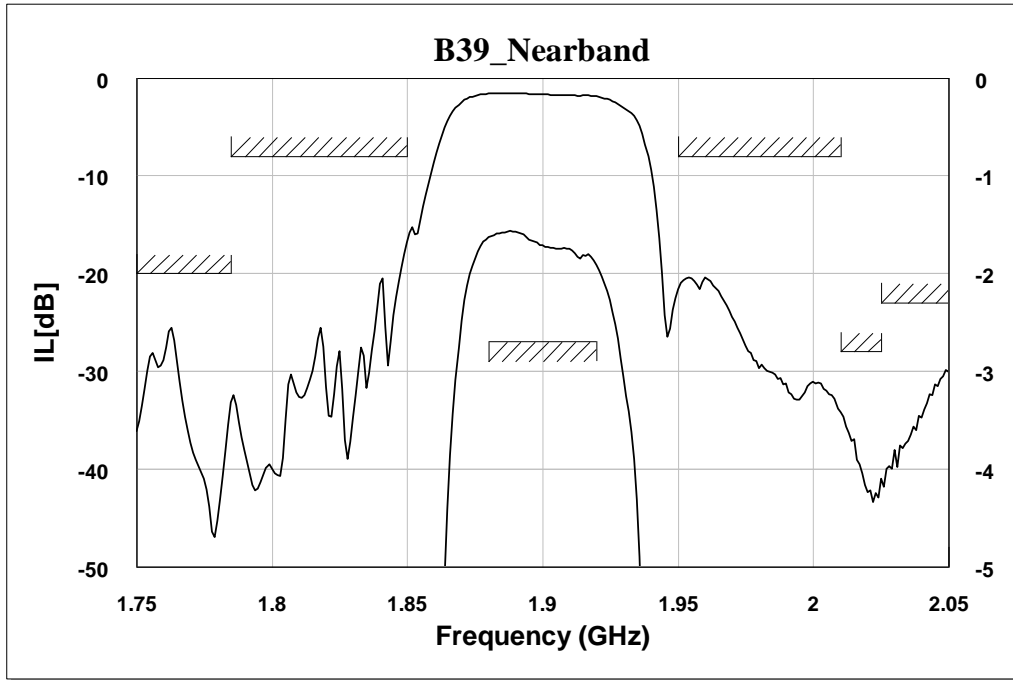

LTE B34

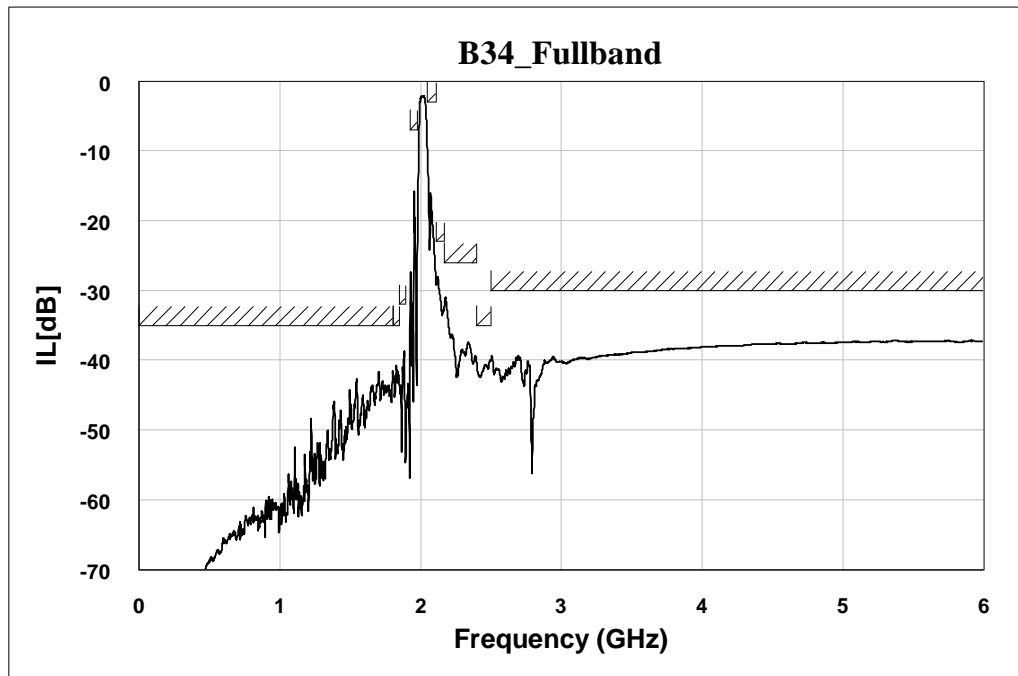
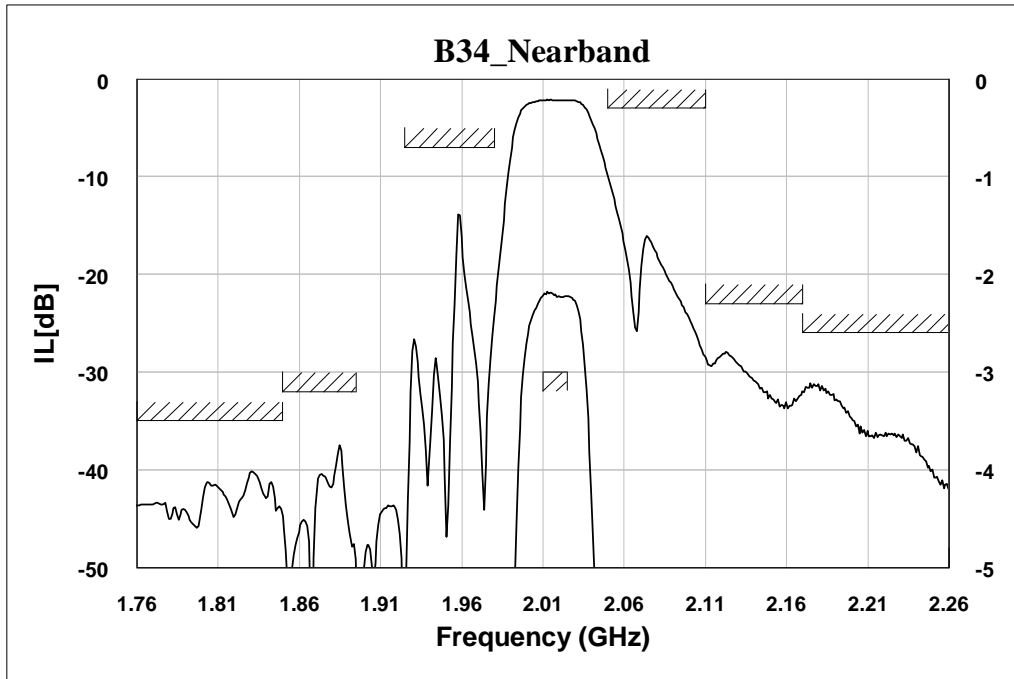

7. RELIABILITY

7-1. ENGINEERING SAMPLE FLOW CHART

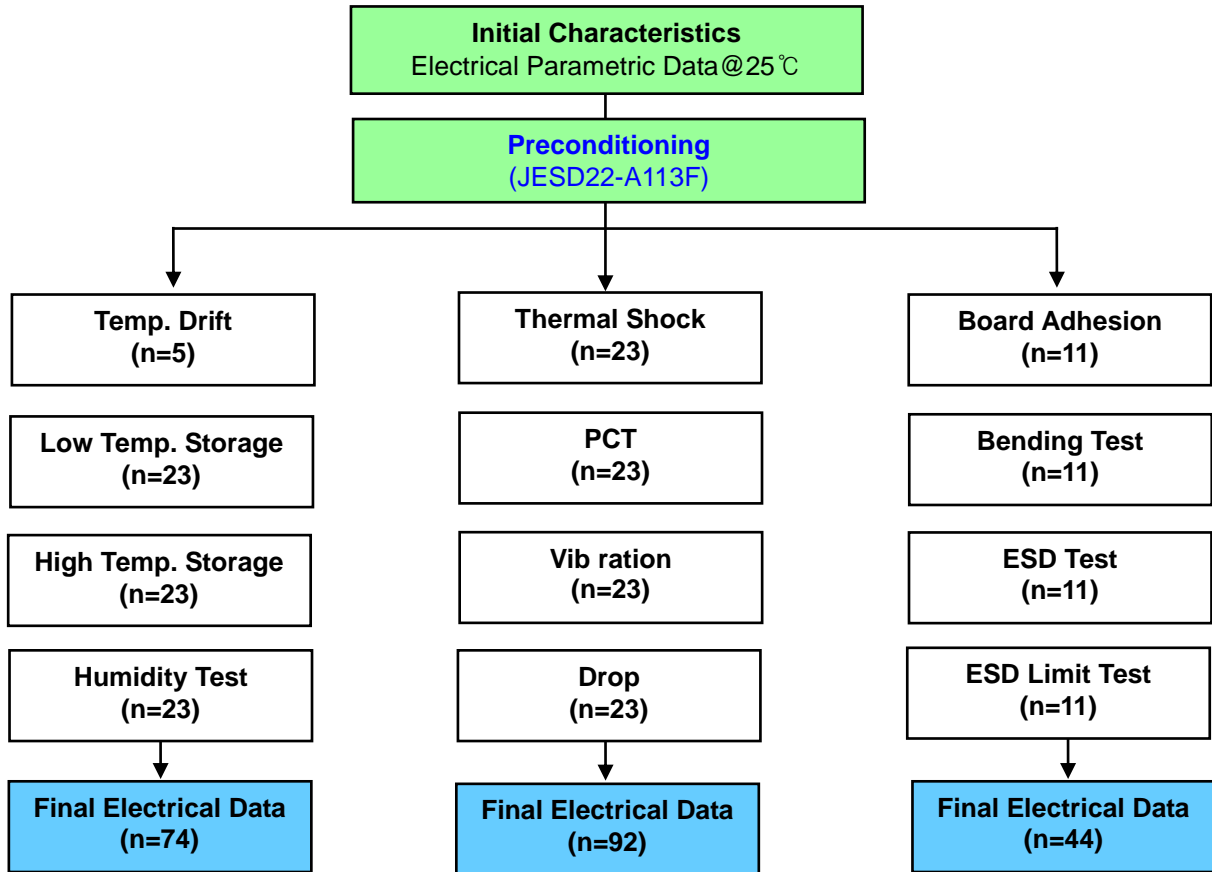

**7-2. TEST ITEM & CONDITION**

CATEGORY	TEST ITEM	TEST CONDITION	REMARK
	Preconditioning	+125℃ 24hr Baking → +60℃ 60%RH 120hr → Reflow Test(3times)	JESD22A113F



Environment Test	Temp. Drift	-30℃ → +25℃ → +85℃	description
	High Temp. Storage	+85℃ 240hr	JESD22-A103C
	Low Temp. Storage	-40℃ 240hr	JESD22-A119
	High Temp. High Humidity Storage	+85℃ 85%RH 240hr	JESD22-A106B
	Thermal Shock	-40℃/30min ⇔ +85℃/30min , 100cycle	JESD22-A106A
	High Temp. Operating	+121℃ 100%RH 96hr	JESD22-A102C
Mechanical Test	Vibration Test (Random)	20 Hz~2000 Hz,0.053G <sup>2</sup> /Hz or 8g's RMS,15min/plane	IEC 68-2-36 Fdb
	Drop Test	152 cm 12times Steel floor JIG(110g~150g)	IEC 1178-1.4.8.9
	Board Adhesion	0.5 mm/sec 1point push	IEC 68-2-21 Ue3
	Bending Test	0.5 mm/sec 3times -PCB : FR4 , PCB SIZE : 100*40 mm	IEC 68-2-21 Ue3
Physical Test	Solder Heat Resistance	±250V,C=100pF,R=1.5 kΩ,1times	IEC 68-2-21 Ue3
	static marginal test	C=100pF,R=1.5 kΩ,1times(demand of customer)	JESD22-A114F

### 8. REFLOW CONDITION

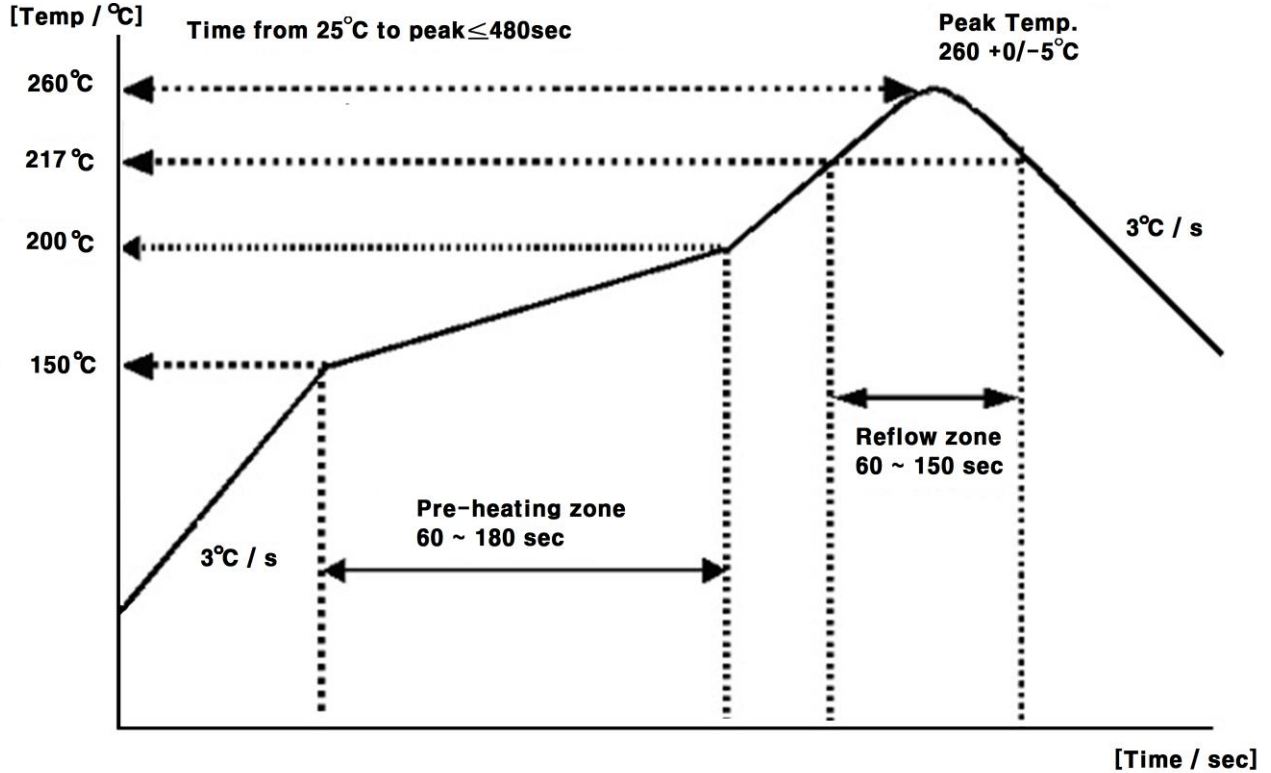

### 9. RECOMMENDED PCB DIMENSIONS

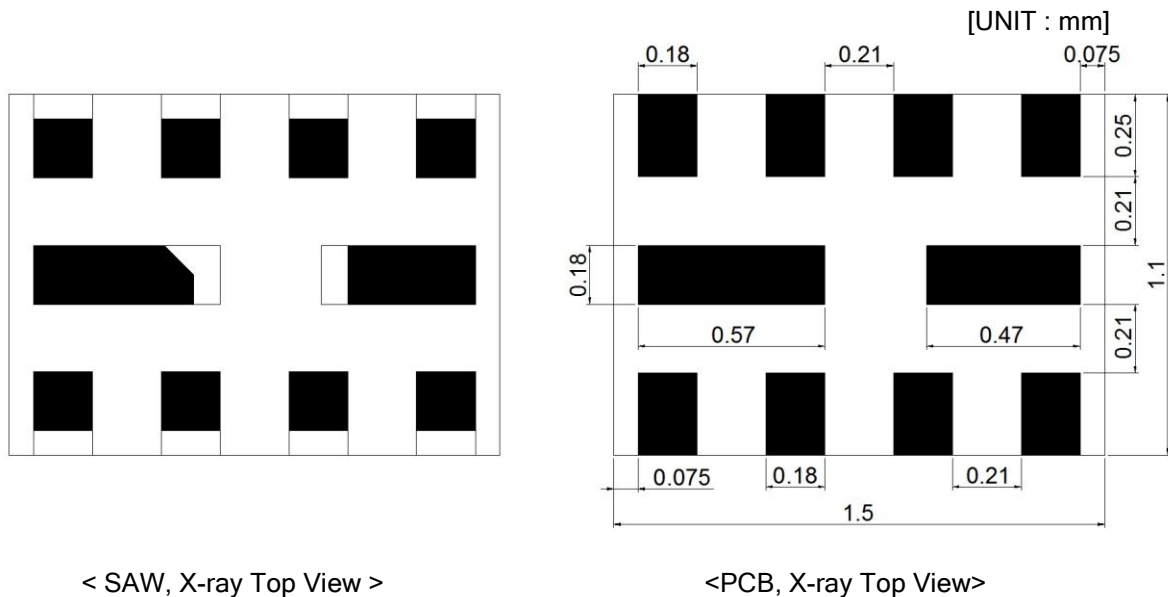

## 10. CAUTION

### Moisture Sensitivity Device Caution (MSL LEVEL=2a)

1. Calculated shelf life in sealed bag : 12 month at < 40℃ and < 90% relative Humidity(RH)
  2. Peak package body temperature : **260℃**
  3. After bag is opened, devices that will be subjected to reflow solder or other high temperature process must be
    - (a) Mounted within : 672 hours of factory conditions ≤30℃/60% RH, or
    - (b) Stored per J-STD-033
  4. Device require bake, before mounting, if :
    - (a) Humidity Indicator Card reads > 60% when read at 23±5℃
    - (b) 3(a) or 3(b) are not met
  5. If baking is required, refer to IPC/JEDEC J-STD-033 for bake procedure
- Note : Level and body temperature defined by IPC/JEDEC J-STD-020

Aluminum Pack (310mmX370mm)



HIC(Humidity Indication Card)

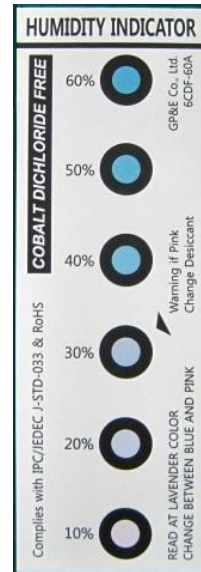

10 to 60% RH

11. PACKING

11-1. DIMENSIONS

- Carrier Tape

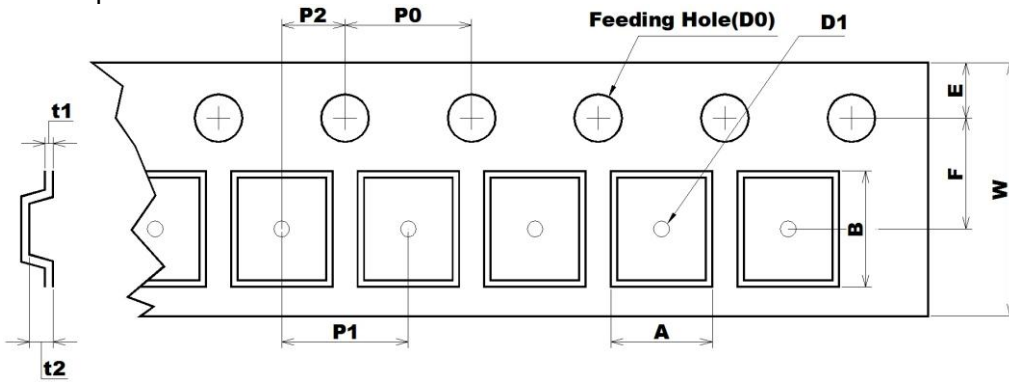

[Unit: mm]

A	B	D0	D1	E	F	P0	P1	P2	t1	t2	W
1.35	1.75	Ø1.50	Ø0.50	1.75	3.50	4.00	4.00	2.00	0.25	0.70	8.00
+0.05	+0.05	+0.10	+0.05	+0.10	+0.05	+0.10	+0.10	+0.05	+0.02	+0.07	+0.30
-0.05	-0.05	-0.00	-0.05	-0.10	-0.05	-0.10	-0.10	-0.05	-0.02	-0.07	-0.10

- Reel

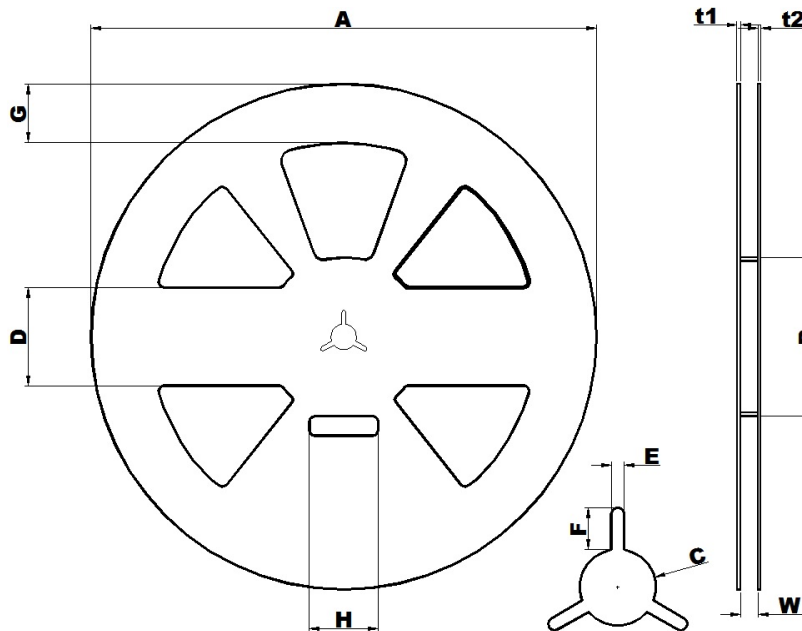

[Unit: mm]

A	B	C	D	E	F	G	H	t1	t2	W
Ø 258.0	Ø 81.0	Ø 13.0	50.0	2.2	7.0	30.0	35.0	1.8	1.5	9.0
+1.0	+1.0	+0.5	+0.8	+0.3	+0.5	+0.8	+1.0	+0.5	+0.5	+1.0
-0.5	-1.0	-0.5	-0.8	-0.3	-0.5	-0.8	-1.0	-0.5	-0.5	-0.5

- The product shall be packed properly not to damaged during transportation and storage.



11-2. REELING QUANTITY

10 inch reel : 8,000 pcs/reel

11-3. TAPING STRUCTURE

11-3-1. The tape shall be wound around the reel in direction shown below.

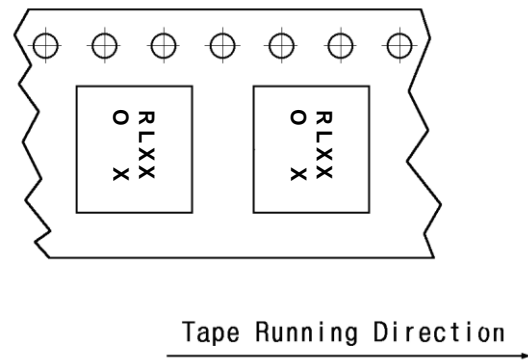
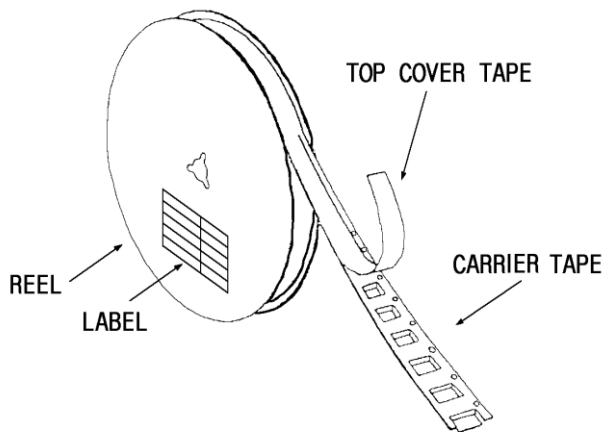

11-3-2. BAR CODE LABEL

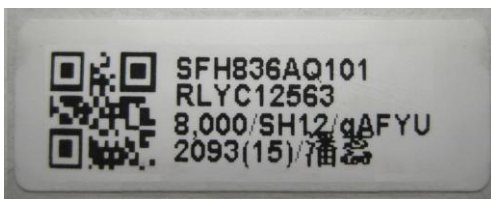

- |   |   |                    |
|---|---|--------------------|
| ① |  | MODEL NAME BARCODE |
| ② | SFH836AQ101   | Model Name         |
| ③ | RLYC12563   | Reel number        |
| ④ | 8,000 / qAFYU   | Quantity / Marking |

1-3-3. Leader part and vacant position specifications.

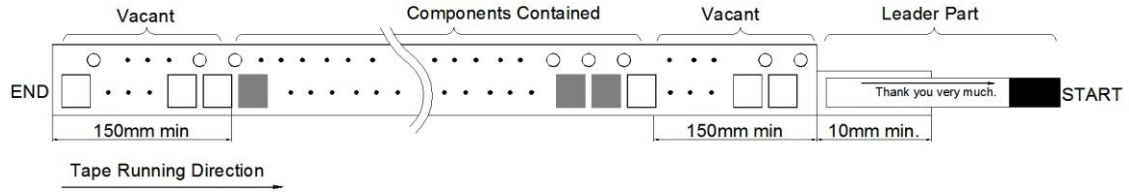

11-4. INNER BOX(Reel Packing) STRUCTURE

Material: Polycarbonate

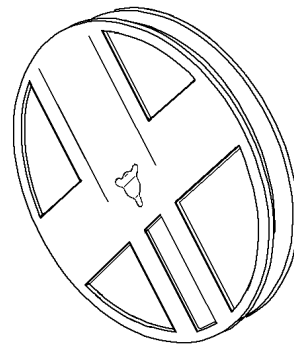

Material: Polyethylene + Aluminium  
 Size: 310×370mm<sup>2</sup>

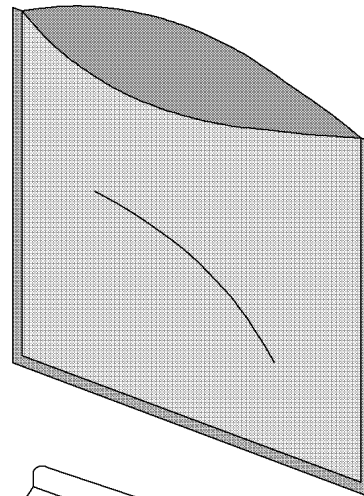

Material: Paper  
 Size: (D)260×(W)37×(H)265mm<sup>3</sup>

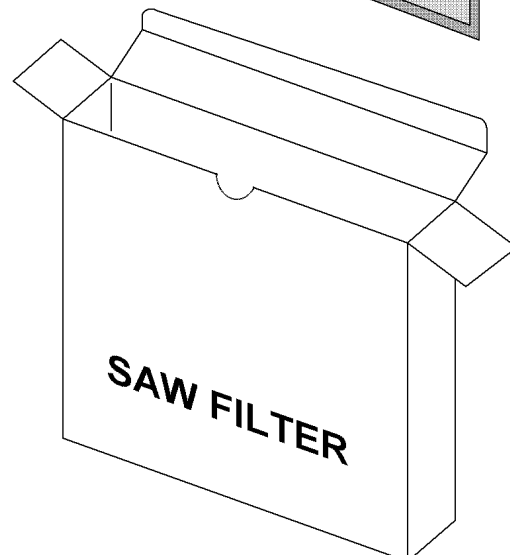

11-5. OUTER BOX STRUCTURE

Material: Paper

TYPE	SIZE(mm)			Inner Box #
	a	b	c	
A	270	240	275	6 boxes

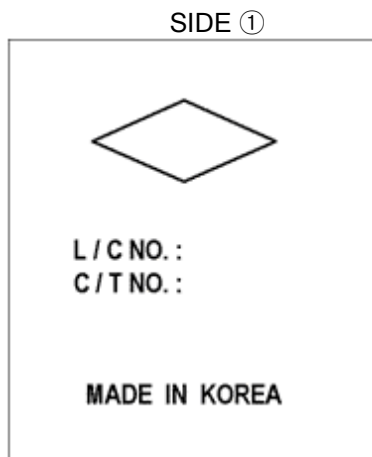
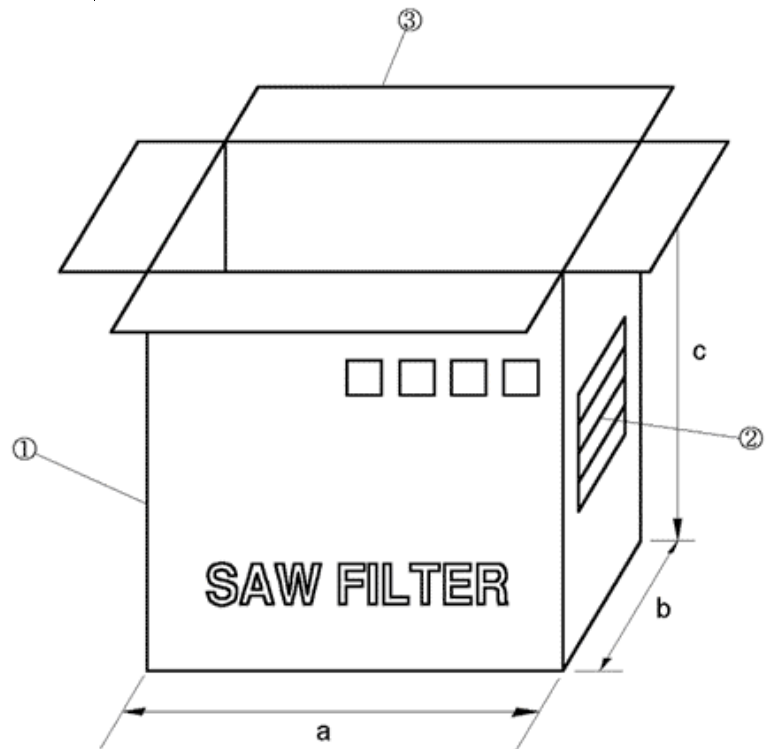

SIDE ②

MODEL	
Q'TY	EA
USER	
DATE	

- SIDE is the same as front side.

## 12. TAPE SPECIFICATIONS

12-1. Tensile Strength of Carrier Tape: 4.4N/mm width

12-2. Top Cover Tape Adhesion (See the below figure)

- pull of angle: 0~15 degree
- speed: 300mm/min.
- force: 20~70g

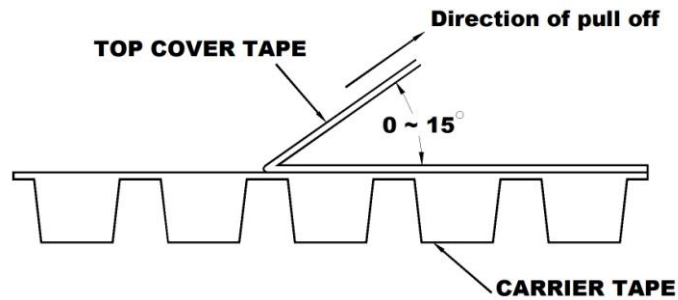

13. RoHS DATA



**Test Report No.** F690101/LF-CTSAYAA13-31939

Issued Date: 2013. 07. 08 Page 1 of 6

To: **WISOL CO., LTD.**  
373-7  
Gajang-dong  
Osan-si  
Gyeonggi-do  
Korea

The following merchandise was submitted and identified by the client as :

SGS File No. : AYAA13-31939  
Product Name : SAW FILTER  
Item No./Part No. : N/A  
Received Date : 2013. 07. 03  
Test Period : 2013. 07. 04 to 2013. 07. 08  
Buyer(s) : SAMSUNG  
Test Results : For further details, please refer to following page(s)  
Test Performed : SGS Korea tested the sample(s) selected by applicant with following results.  
Test Comments : By the applicant's specific request, the sampling and testing was performed only for the part indicated in the photo without disassembly.

Timothy Jeon  
Jinhee Kim  
Cindy Park  
Jerry Jung/ Testing Person

SGS Korea Co., Ltd.



Jeff Jang / Chemical Lab Mgr

Document is issued by the Company subject to the General Conditions of Service (printed material) available on request or accessible at <http://www.sgs.com/chemical/conditions.htm> and, for electronic format documents, subject to Terms and Conditions for Electronic Documents at <http://www.sgs.com/chemical/electronic.htm>. Operator is aware of the limitation of liability, indemnification and jurisdiction clause outlined therein. Any issue of the document is subject to the information contained therein reflects the Company's findings at the time of its preparation only and within the limits of Client's instructions. If the Company's work responsibility is to be Client and this document does not constitute parties to a transaction from existing at the time and obligations under the transaction documents. This document cannot be reproduced except in full without prior written approval of the Company. Any unauthorized alteration or distribution of the content or appearance of this document is prohibited and offenders may be prosecuted to the fullest extent of the law. All information related to this test report refers only to the sample(s) tested and each sample(s) are retained for 30 days only.





**Test Report No.** F690101/LF-CTSAYAA13-31939

Issued Date: 2013. 07. 08 Page 3 of 6

**Sample No.** : AYAA13-31939.001  
**Sample Description** : SAW FILTER  
**Item No./Part No.** : N/A  
**Materials** : N/A

**Flame Retardants-PBBs/PBDEs**

Test Items	Unit	Test Method	MDL	Results
Decabromodiphenyl ether	mg/kg	With reference to IEC 62321:2008, GC-MS	5	N.D.

**Halogen Content**

Test Items	Unit	Test Method	MDL	Results
Bromine(Br)	mg/kg	BS EN 14582:2007 , IC	30	N.D.
Chlorine(Cl)	mg/kg	BS EN 14582:2007 , IC	30	N.D.

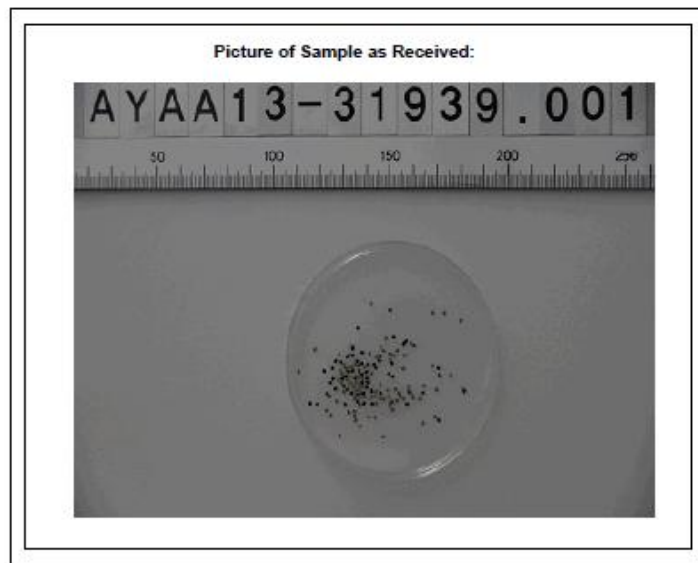

**NOTE:**

- (1) N.D. = Not detected.(<MDL)
- (2) mg/kg = ppm
- (3) MDL = Method Detection Limit
- (4) - = No regulation
- (5) Negative = Undetectable / Positive = Detectable
- (6) \*\* = Qualitative analysis (No Unit)
- (7) \* = Boiling-water-extraction:  
Negative = Absence of CrVI coating  
Positive = Presence of CrVI coating; the detected concentration in boiling-water-extraction solution is equal or greater than 0.02 mg/kg with 50 cm<sup>2</sup> sample surface area.

This document is issued by the Company subject to the General Conditions of Service printed hereon, available on request at [www.sgs.com/ServiceConditions.pdf](http://www.sgs.com/ServiceConditions.pdf), for electronic format documents, subject to Terms and Conditions for Electronic Documents at [www.sgs.com/ServiceConditions.pdf](http://www.sgs.com/ServiceConditions.pdf). Reference is drawn to the limitation of liability, indemnification and jurisdiction clause without breach. Any holder of this document is advised that information contained herein reflects the Company's findings at the time of its issuance only and within the limits of Client's instructions. If any. The Company's sole responsibility is to its Client and this document does not constitute either a transaction nor involving at their rights and obligations under the transaction documents. This document cannot be reproduced except in full, without prior written approval of the Company. Any unauthorized alteration, copying or modification of the content or appearance of this document is prohibited and offenders may be prosecuted to the fullest extent of the law. Client's attention is drawn that the results shown in this test report refer only to the sample(s) tested and such results are not related to 3C display.





Test Report No. F690101/LF-CTSAYAA13-31939

Issued Date: 2013. 07. 08 Page 4 of 6

Testing Flow Chart for RoHS: Cd/Pb/Hg/Cr<sup>6+</sup> /PBBs&PBDEs Testing

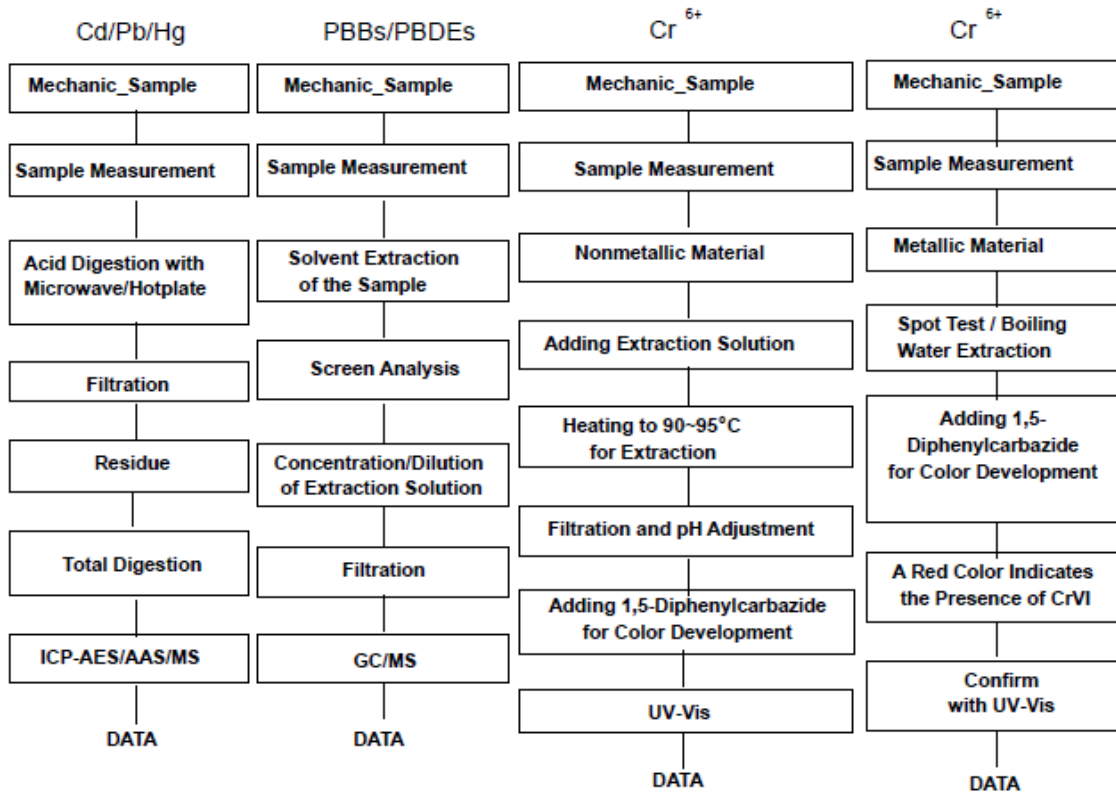

The samples were dissolved totally by pre-conditioning method according to above flow chart for Cd,Pb,Hg.  
Section Chief : Gilsae Yi

NOTE:

- (1) N.D. = Not detected.(<MDL)
- (2) mg/kg = ppm
- (3) MDL = Method Detection Limit
- (4) - = No regulation
- (5) Negative = Undetectable / Positive = Detectable
- (6) \*\* = Qualitative analysis (No Unit)
- (7) \* = Boiling-water-extraction:  
Negative = Absence of CrVI coating  
Positive = Presence of CrVI coating: the detected concentration in boiling-water-extraction solution is equal or greater than 0.02 mg/kg with 50 cm<sup>2</sup> sample surface area.

The document is issued by the Company subject to the General Conditions of Service (attached herewith) available on request or accessible at <http://www.sgs.com/ProductsandServices/rohs.htm> for electronic format documents subject to Terms and Conditions for Electronic Documents at <http://www.sgs.com/ProductsandServices/rohs.htm>. Attention is drawn to the limitation of liability, indemnification and jurisdiction clause defined therein. Any value of the document is subject to the information contained therein which is the Company's finding at the time of its intervention only and under the limit of Client's instructions. If any of the Company's sole responsibility is to the Client and the document does not constitute parties to a transaction from accepting all their rights and obligations under the transaction documents. The document cannot be reproduced without the written prior approval of the Company. Any unauthorized alteration, forgery or falsification of the content or appearance of this document is unlawful and offenders may be prosecuted to the fullest extent of the law. Please reference against the results shown in this test report only to the accuracy, tested and used equipment are indicated for 30 days only.





Test Report No. F690101/LF-CTSAYAA13-31939

Issued Date: 2013. 07. 08 Page 5 of 6

**Flow Chart for Inorganic Elements Testing**

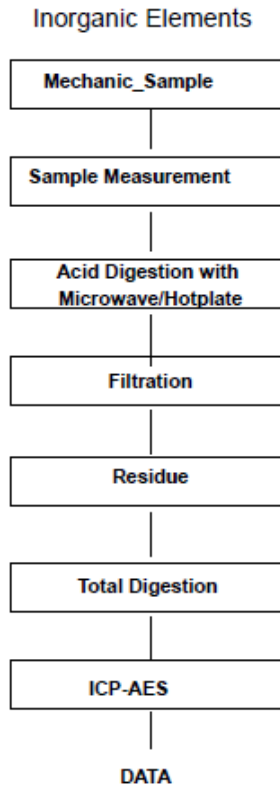

**NOTE:**

- (1) N.D. = Not detected.(<MDL)
- (2) mg/kg = ppm
- (3) MDL = Method Detection Limit
- (4) - = No regulation
- (5) Negative = Undetectable / Positive = Detectable
- (6) \*\* = Qualitative analysis (No Unit)
- (7) \* = Boiling-water-extraction:  
 Negative = Absence of CrVI coating  
 Positive = Presence of CrVI coating; the detected concentration in boiling-water-extraction solution is equal or greater than 0.02 mg/kg with 50 cm<sup>2</sup> sample surface area.

\* Document is issued by the Company subject to its General Conditions of Service printed hereon, available on request or accessible at <http://www.sgs.com/ClientandConditions.aspx> and, for electronic format documents, subject to Terms and Conditions for Electronic Documents at <http://www.sgs.com/ClientandConditions.aspx>. Attention is drawn to the limitation of liability, indemnification and jurisdiction clause printed hereon. Any holder of this document is advised that information contained herein reflects the Company's findings at the time of its intervention only and within the limits of Client's instructions. If the Company's work responsibility is to be Client and this document does not constitute part of a transaction, from receiving it, their rights and obligations under the transaction document. This document cannot be reproduced, stored in a retrieval system or transmitted in any form or by any means, electronic, mechanical, photocopying, recording, or by any information storage and retrieval system, without prior written approval of the Company. Any unauthorized alteration, forgery or falsification of the content or appearance of this document is unlawful and offenders may be prosecuted to the fullest extent of the law. See also disclaimer printed on the inside cover of this test report when only the sample(s) tested and each sample(s) are retained for 90 days only.



Test Report No. F690101/LF-CTSAYAA13-31939

Issued Date: 2013. 07. 08 Page 6 of 6

Flow Chart for Halogen Test

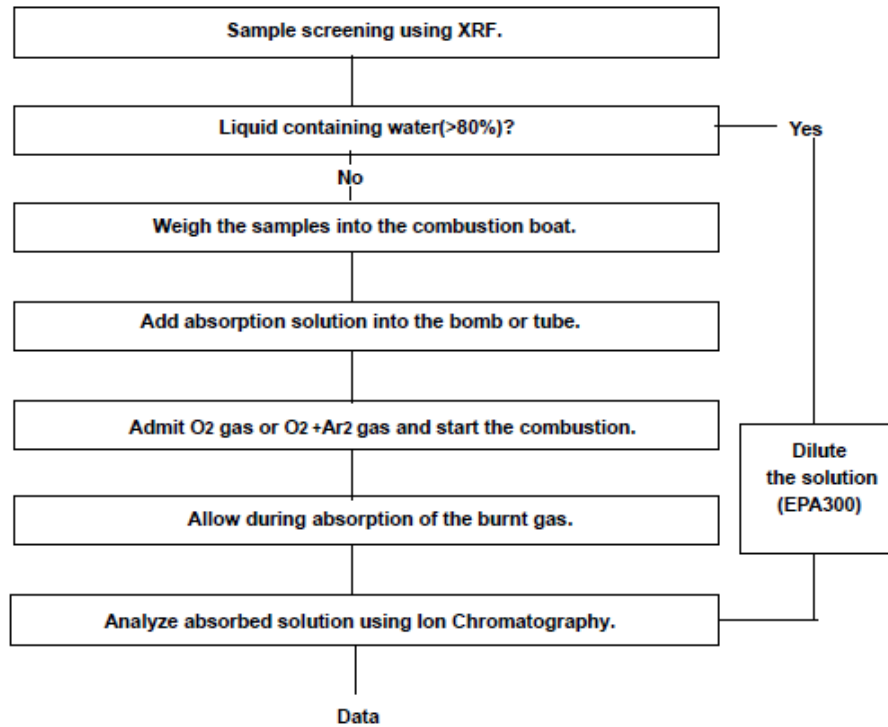

\*\*\* End \*\*\*

NOTE:

- (1) N.D. = Not detected.(<MDL)
- (2) mg/kg = ppm
- (3) MDL = Method Detection Limit
- (4) - = No regulation
- (5) Negative = Undetectable / Positive = Detectable
- (6) \*\* = Qualitative analysis (No Unit)
- (7) \* = Boiling-water-extraction:  
Negative = Absence of CrVI coating  
Positive = Presence of CrVI coating; the detected concentration in boiling-water-extraction solution is equal or greater than 0.02 mg/kg with 50 cm2 sample surface area.

This document is issued by the Company subject to its General Conditions of Service (printed version) available on request or accessible at <http://www.sgs.com/ChinaandSoutheastAsia> and, for electronic format documents, subject to Terms and Conditions for Electronic Documents at <http://www.sgs.com/ChinaandSoutheastAsia>. Attention is drawn to the limitation of liability, indemnification and jurisdiction issues defined therein. Any holder of this document is advised that information contained herein reflects the Company's findings at the time of its intervention only and within the limits of Client's instructions. It is the Client's sole responsibility as to the Client and this document does not constitute advice in a transaction from assessing all their rights and obligations under the transaction documents. This document cannot be reproduced except in full, without prior written approval of the Company. Any unauthorized alteration, forgery or falsification of the content or appearance of this document is unlawful and offenders may be prosecuted to the fullest extent of the law. (See also below under the conditions in the test report only (see the samples) (label and each sample)) are retained for 30 days only.