

1.Features

- $V_{DS(V)}=100V$
- $I_D=80A$
- $R_{DS(ON)}<7.2m\Omega(V_{GS}=10V)$
- Ideal for high-frequency switching and synchronous rectification
- N-channel, normal level
- Very low on-resistance $R_{DS(ON)}$
- 175 °C operating temperature
- Pb-free lead plating RoHS compliant

2.Pinning information

Pin	Symbol	Description
1	G	GATE
2	D	DRAIN
3	S	SOURCE

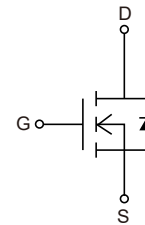
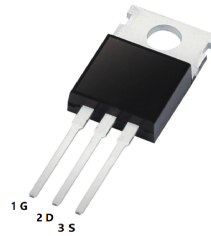

3.Absolute Maximum Ratings $T_C= 25^{\circ}C$

Parameter	Symbol	Conditions	Rating	Units
Continuous drain current	I_D	$T_C=25^{\circ}C^{2)}$	80	A
		$T_C=100^{\circ}C$	70	A
Pulsed drain current ²⁾	$I_{D,pulse}$	$T_C=25^{\circ}C$	320	A
Avalanche energy, single pulse	E_{AS}	$I_D=80A, R_{GS}=25\Omega$	160	mJ
Gate source voltage	V_{GS}		± 20	V
Power dissipation	P_{tot}	$T_C=25^{\circ}C$	150	W
storage temperature	T_J, T_{STG}		-55 to 175	$^{\circ}C$
IEC climatic category; DIN IEC 68-1			55/175/56	



4. Electrical Characteristic (T_c=25°C unless otherwise noted)

Parameter	Symbol	Conditions	Min	Typ	Max	Units
Thermal resistance, junction -case	R _{thJC}				1	K/W
Thermal resistance, junction -ambient	R _{thJA}	minimal footprint			62	K/W
		6 cm ² cooling area ³⁾			40	K/W
Drain-source breakdown voltage	V _{(BR)DSS}	V _{GS} =0V, I _D =1mA	100			V
Gate threshold voltage	V _{GS(th)}	V _{DS} =V _{GS} , I _D =90μA	2	2.7	3.5	V
Zero gate voltage drain current	I _{DSS}	V _{DS} =100V, V _{GS} =0V, T _J =25°C		0.1	1	μA
		V _{DS} =100V, V _{GS} =0V, T _J =125°C		10	100	μA
Gate-source leakage current	I _{GSS}	V _{GS} =20V, V _{DS} =0V		1	100	nA
Drain-source on-state resistance	R _{DS(ON)}	V _{GS} =10V, I _D =80A		6.2	7.2	mΩ
		V _{GS} =6V, I _D =40A		7.6	12.7	Ω
Gate resistance	R _G			1.6		S
Transconductance	g _{FS}	V _{DS} >2 I _D R _{DS(ON)max} , I _D =80A	50	99		μF
Input capacitance	C _{iss}	V _{GS} =0V, V _{DS} =50V, f=1MHz		3690	4910	pF
Output capacitance	C _{oss}			646		pF
Reverse transfer capacitance	C _{rss}			25		ns
Turn-on delay time	t _{D(on)}	V _{DD} =50V, V _{GS} =10V I _D =80A, R _G =3.6Ω		19		ns
Rise time	t _r			37		ns
Turn-off delay time	t _{D(off)}			37		ns
Fall time	t _f			9		nC
Gate to source charge	Q _{gs}	V _{DD} =50V, I _D =80A V _{GS} =0 to 10V		18		nC
Gate to drain charge	Q _{gd}			10		nC
Switching charge	Q _{sw}			16		nC
Gate charge total	Q _g			51	68	nC
Gate plateau voltage	V _{plateau}				4.9	



Output charge	Q_{oss}	$V_{DD}=50V, V_{GS}=0V$		68	91	nC
Diode continuous forward current	I_S	$T_C=25^\circ C$			80	A
Diode pulse current	$I_{S,pulse}$				320	A
Diode forward voltage	V_{SD}	$V_{GS}=0V, I_F=80A, T_J=25^\circ C$		1	1.2	V
Reverse recovery time	t_{rr}	$V_R=50V, I_F=I_S, di_F/dt=100A/\mu s$		73		ns
Reverse recovery charge	Q_{rr}	$V_R=50V, I_F=I_S, di_F/dt=100A/\mu s$		139		nC

Notes:

6) See figure 16 for gate charge parameter definition.



5.1 Typical characteristic

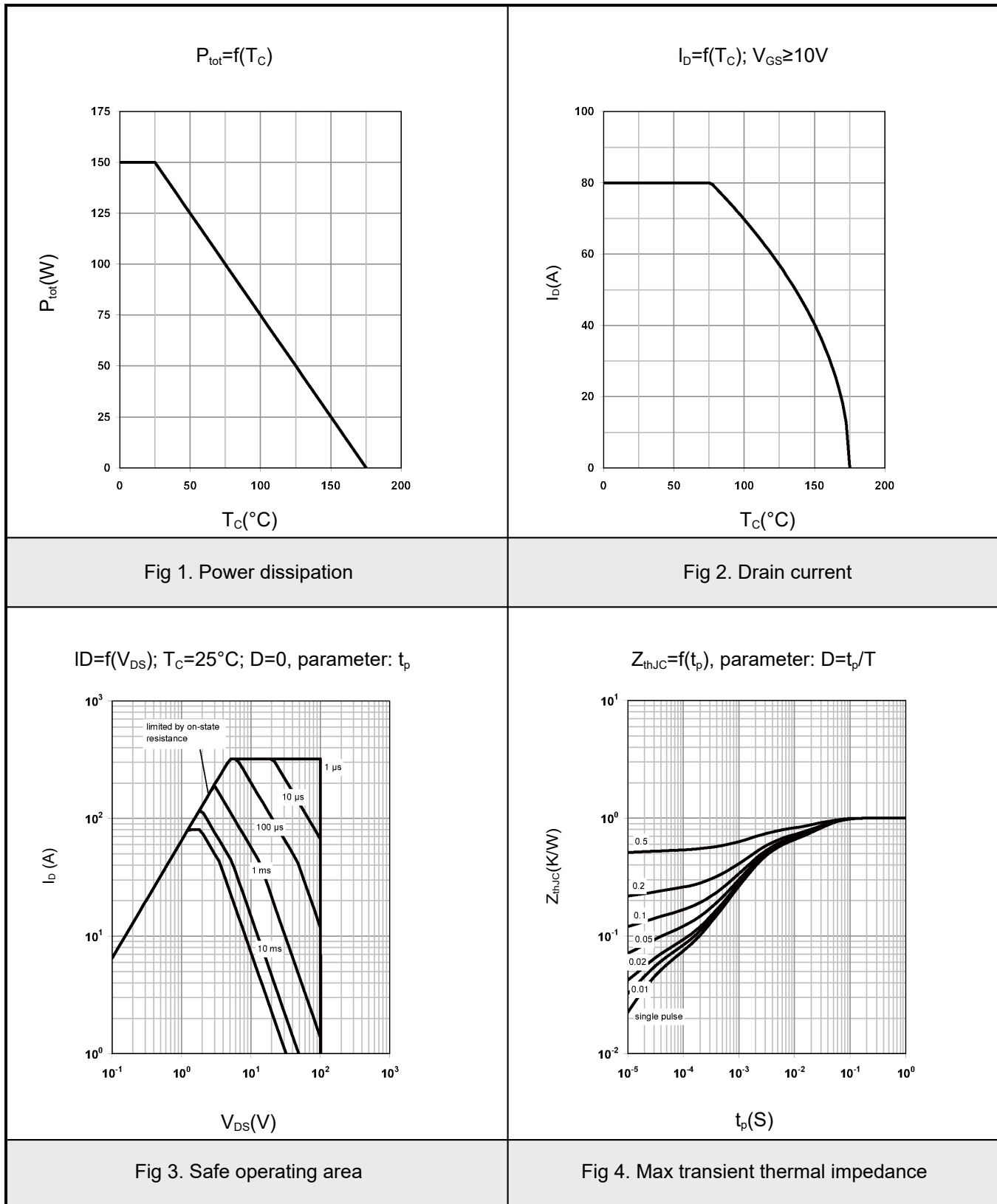



5.2 Typical characteristic

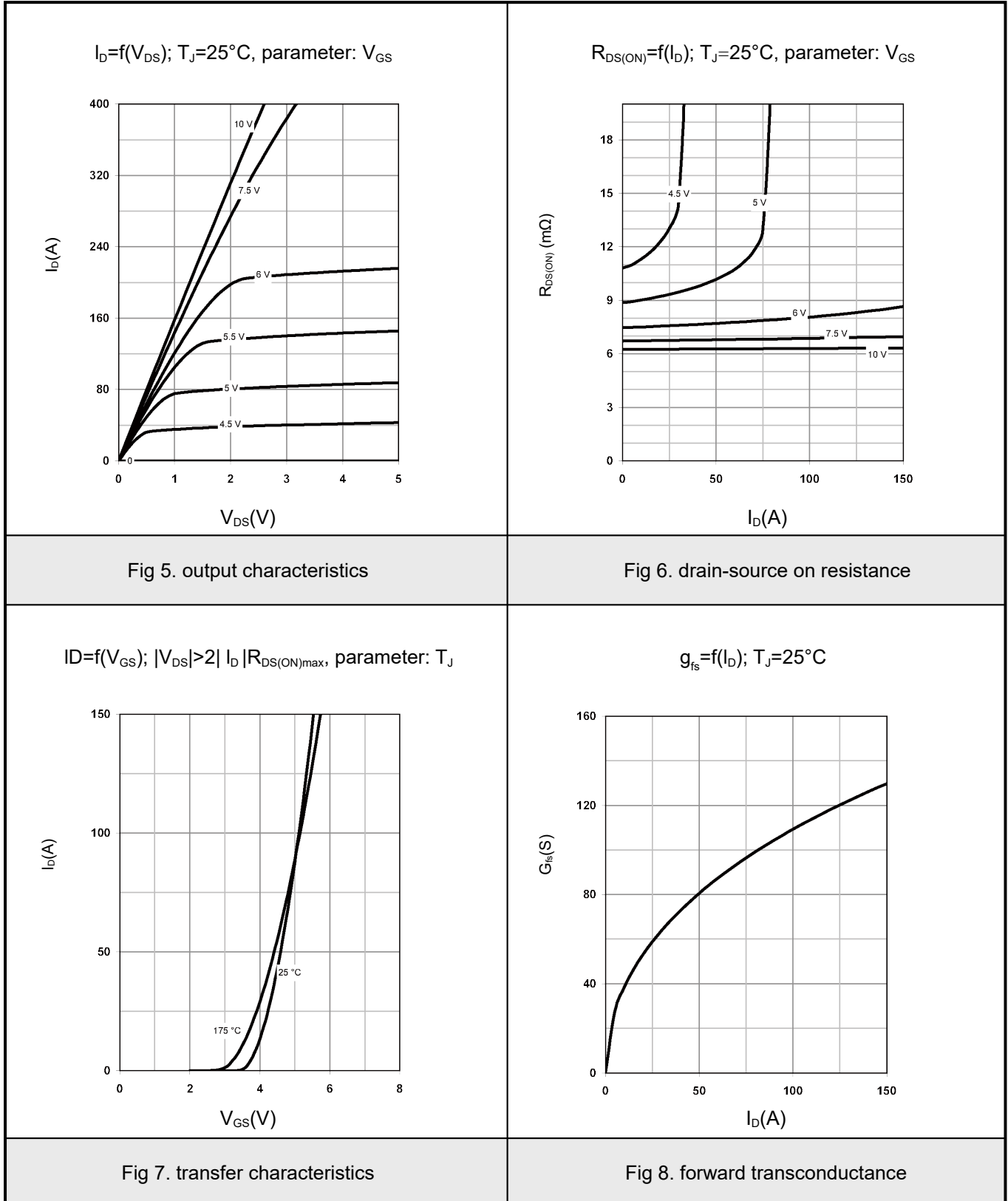



5.3 Typical characteristic

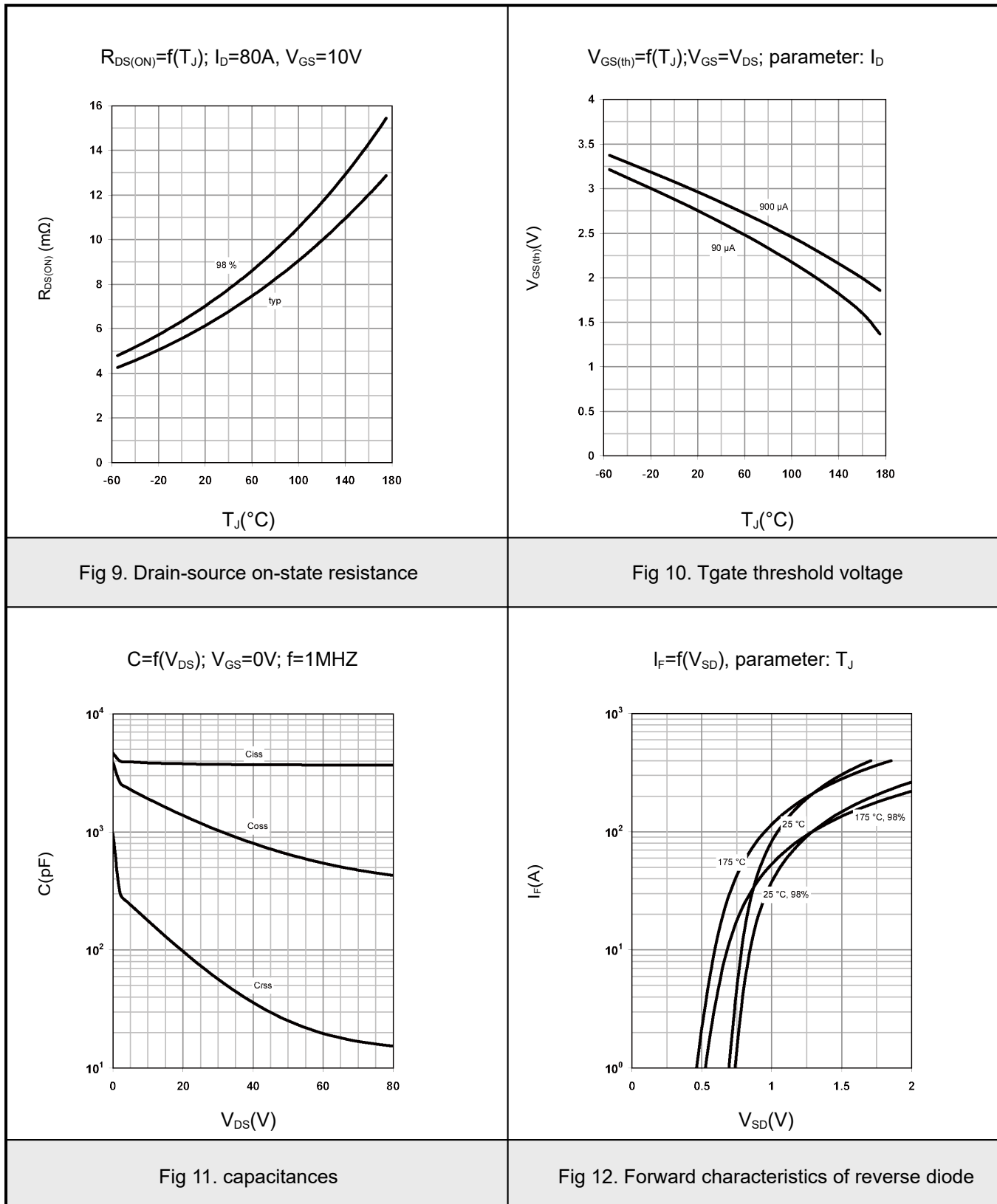



5.4 Typical characteristic

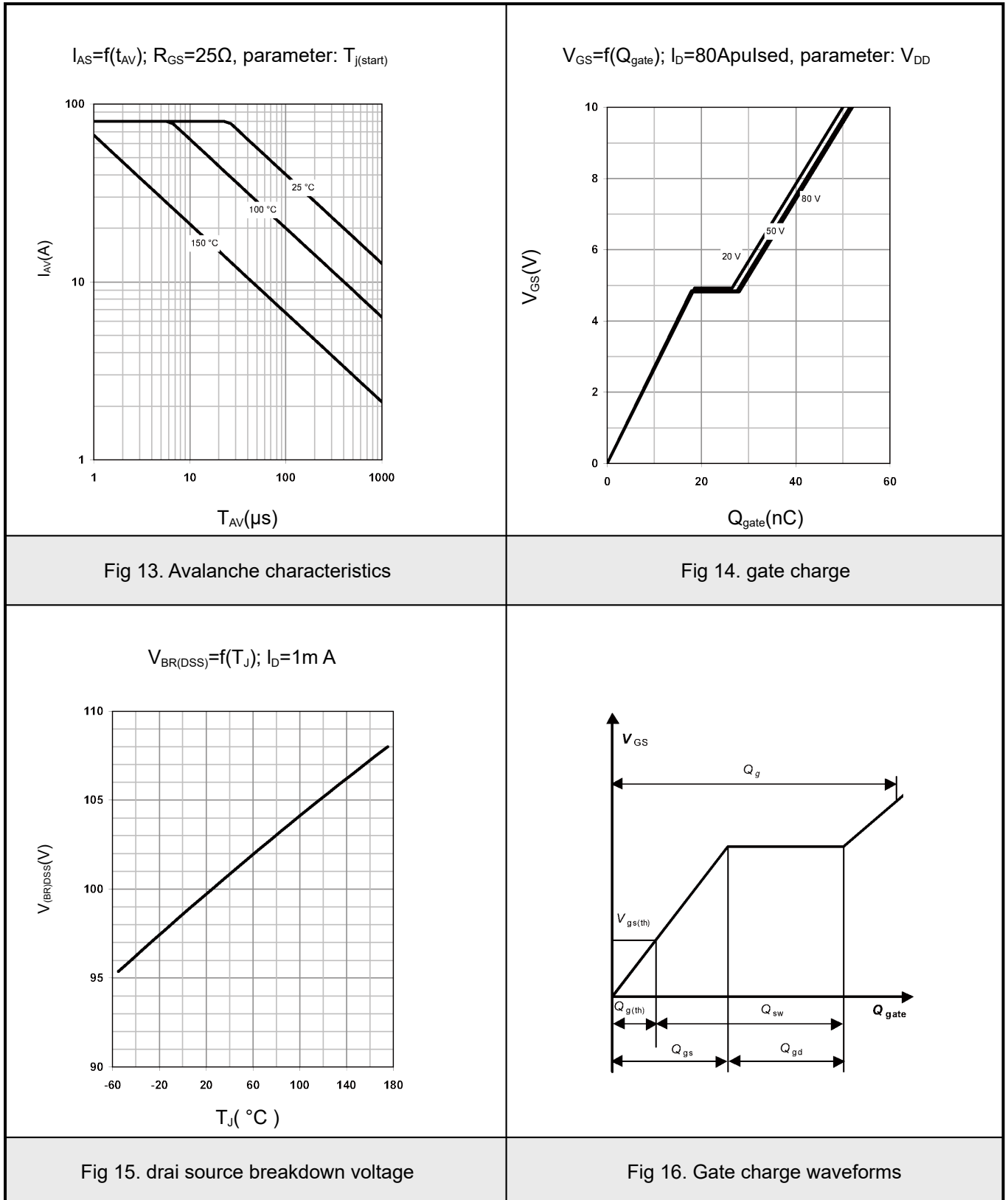



6.TO-220 Package Outline Dimensions

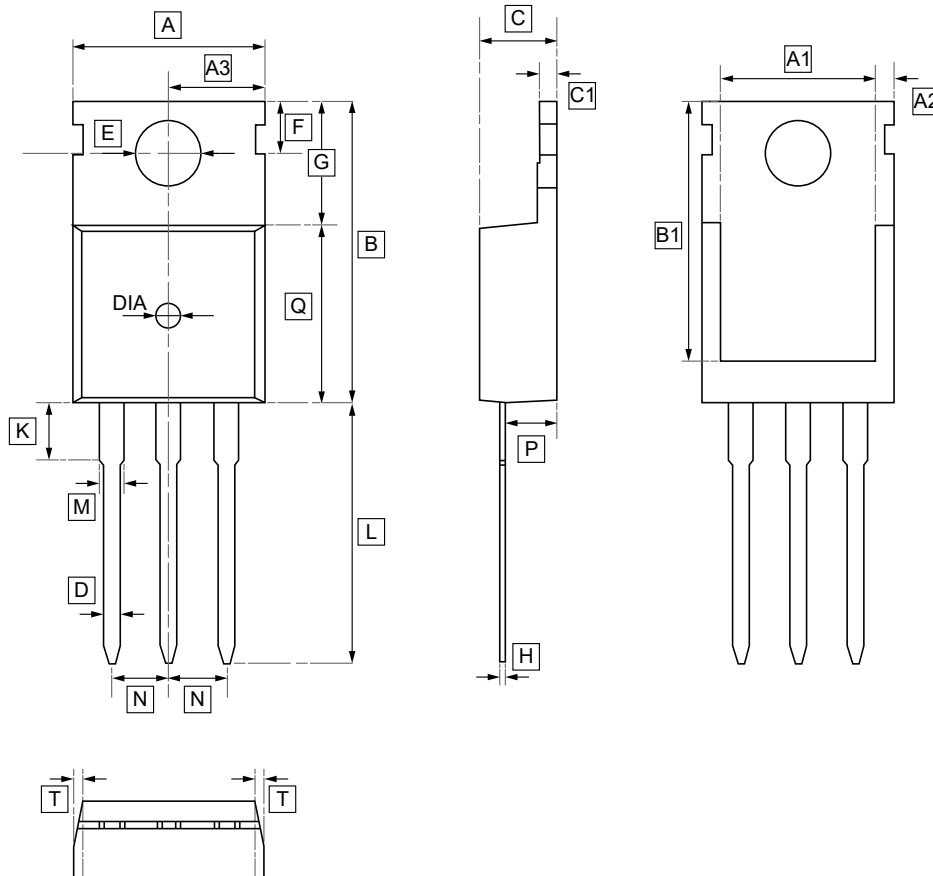

DIMENSIONS (mm are the original dimensions)

Symbol	A	A1	A2	A3	B	B1	C	C1	D	E	F	G
Min	9.7	8.44	1.05	4.8	15.4	12.9	4.28	1.1	0.6	3.4	2.65	5.2
Max	10.3	8.84	1.25	5.2	16.2	13.5	4.68	1.5	1.0	3.8	3.25	5.8

Symbol	H	K	L	L1	M	N	P	Q	T	DIA
Min	0.4	2.9	12.8	2.7	1.15	2.49	2.1	8.7	W:0.35	⊙1.5
Max	0.6	3.3	13.6	3.3	1.35	2.59	2.7	9.3		(deep 0.2)



7.Ordering information

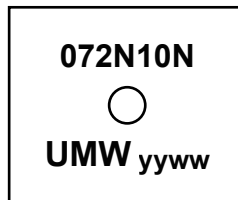

yy: Year Code
ww: Week Code

Order Code	Package	Base QTY	Delivery Mode
UMW IPP072N10N3G	TO-220	1000	Tube and box



8.Disclaimer

UMW reserves the right to make changes to all products, specifications. Customers should obtain the latest version of product documentation and verify the completeness and currency of the information before placing an order.

When applying our products, please do not exceed the maximum rated values, as this may affect the reliability of the entire system. Under certain conditions, any semiconductor product may experience faults or failures. Buyers are responsible for adhering to safety standards and implementing safety measures during system design, prototyping, and manufacturing when using our products to prevent potential failure risks that could lead to personal injury or property damage.

Unless explicitly stated in writing, UMW products are not intended for use in medical, life-saving, or life-sustaining applications, nor for any other applications where product failure could result in personal injury or death. If customers use or sell the product for such applications without explicit authorization, they assume all associated risks.

When reselling, applying, or exporting, please comply with export control laws and regulations of China, the United States, the United Kingdom, the European Union, and other relevant countries, regions, and international organizations.

This document and any actions by UMW do not grant any intellectual property rights, whether express or implied, by estoppel or otherwise. The product names and marks mentioned herein may be trademarks of their respective owners.