

1. Description

This N-channel MOSFET has been designed specifically to improve the overall efficiency of DC/DC converters using either synchronous or conventional switching PWM controllers. It has been optimized for low gate charge, low $R_{DS(ON)}$ and fast switching speed.

2. Features

- $V_{DS(V)}=30V$
- $I_D=7A(V_{GS}=10V)$
- $R_{DS(ON)}<23m\Omega(V_{GS}=10V)$
- $R_{DS(ON)}<30m\Omega(V_{GS}=4.5V)$
- Low gate charge

3. Pinning information

Pin	Symbol	Description
4	G	GATE
1,2,3	S	SOURCE
5,6,7,8	D	DRAIN

SOP-8

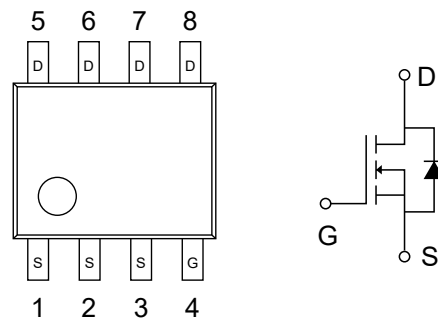

4. Absolute Maximum Ratings $T_A=25^\circ C$ unless otherwise noted

Parameter	Symbol	Rating	Units
Drain to Source Voltage	V_{DS}	30	V
Gate to Source Voltage	V_{GS}	± 20	V
Drain Current Continuous	I_D	7	A
Pulsed (Note 1a)		30	A
Single Pulse Avalanche Energy (Note 2)	E_{AS}	32	mJ
Power dissipation	P_D	1.6	W
Derate above $25^\circ C$		13	mW/ $^\circ C$
Operating and Storage Temperature	T_J, T_{STG}	-55 to 150	$^\circ C$



5. Thermal Characteristics

Parameter	Symbol	Rating	Units
Thermal Resistance, Junction-to-Ambient (Note 1a)	$R_{\theta JA}$	78	$^{\circ}C/W$
Thermal Resistance, Junction-to-Case (Note 1)	$R_{\theta JA}$	40	$^{\circ}C/W$



6. Electrical Characteristics (T_J=25°C unless otherwise noted)

Parameter	Symbol	Conditions	Min	Typ	Max	Units
Drain-Source Breakdown Voltage	BV _{DSS}	I _D =250μA, V _{GS} =0V	30			V
Breakdown Voltage Temperature Coefficient	$\frac{\Delta BV_{DSS}}{\Delta T_J}$	I _D =250μA Referenced to 25°C		23		mV/°C
Zero Gate Voltage Drain Current	I _{DSS}	V _{DS} =24V, V _{GS} =0V			1	μA
		T _J =125°C			250	μA
Gate to Source Leakage Current	I _{GSS}	V _{GS} =±20V, V _{DS} =0V			±100	nA
Gate to Source Threshold Voltage	V _{GS(th)}	V _{DS} =V _{GS} , I _D =250μA	1.2	1.7	2.5	V
Gate to Source Threshold Voltage Temperature Coefficient	$\frac{\Delta V_{GS(th)}}{\Delta T_J}$	I _D =250μA Referenced to 25°C		-4.3		mV/°C
Drain to Source On Resistance	R _{DS(on)}	V _{GS} =10V, I _D =7A		19	23	mΩ
		V _{GS} =4.5V, I _D =6A		24	30	mΩ
Input Capacitance	C _{iss}	V _{DS} =15V		475	635	pF
Output Capacitance	C _{oss}	V _{GS} =0V		100	135	pF
Reverse Transfer Capacitance	C _{rss}	f = 1MHz		65	100	pF
Gate Resistance	R _G	f = 1MHz		0.9	1.6	Ω
Turn-On DelayTime	t _{D(on)}	V _{DD} =15V, I _D =7A V _{GS} =10V, R _{GS} =33Ω		5	10	ns
Rise Time	t _r			9	18	ns
Turn-Off DelayTime	t _{D(off)}			42	68	ns
Fall Time	t _f			21	34	ns
Total Gate Charge	Q _g		V _{DS} =15V, I _D =7A, V _{GS} =10V		9.2	13
Total Gate Charge	Q _g	V _{DS} =15V, I _D =7A V _{GS} =5V		5	7	nC
Gate to Source Gate Charge	Q _{gs}			1.5		nC
Gate to Drain "Miller" Charge	Q _{gd}			2		nC
Source to Drain Diode Voltage	V _{SD}	I _{SD} =7A		0.9	1.25	V
		I _{SD} =2.1A		0.8	1	V



Diode Reverse Recovery Time	t_{rr}	$I_F=7A, d_{IF}/d_t=100A/\mu s$		33	nS
Diode Reverse Recovery Charge	Q_{rr}			20	nC

Notes:

1. $R_{\theta JA}$ is the sum of the junction-to-case and case-to-ambient resistance where the case thermal reference is defined as the solder mounting surface of the drain pins. $R_{\theta JC}$ is guaranteed by design while $R_{\theta CA}$ is determined by the user's board design.

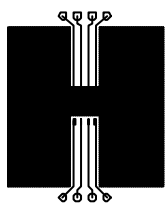

a) 78°C/W when mounted on a 0.5in² pad of 2 oz copper.

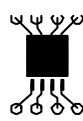

b) 125° C/W when mounted on a 0.02 in² pad of oz. copper.

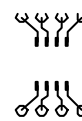

c) 135° C/W when mounted on a minimum pad.

Scale 1 : 1 on letter size paper

2: Starting $T_J = 25^\circ C$, $L = 1mH$, $I_{AS} = 8A$, $V_{DD} = 27V$, $V_{GS} = 10V$.

3: Pulse Test: Pulse Width <300μs, Duty Cycle <2%.



7.1 TYPICAL ELECTRICAL AND THERMAL CHARACTERISTICS

<p>Figure 1: On-Region Characteristics.</p>	<p>Figure 2: On-Resistance Variation with Drain Current and Gate Voltage.</p>
<p>Figure 3: On-Resistance Variation with Temperature.</p>	<p>Figure 4: On-Resistance vs Gate to Source Voltage.</p>
<p>Figure 5: Transfer Characteristics.</p>	<p>Figure 6: Source to Drain Diode Forward Voltage vs Source Current.</p>



7.2 TYPICAL ELECTRICAL AND THERMAL CHARACTERISTICS

<p>Figure 7: Gate-Charge Characteristics.</p>	<p>Figure 8: Capacitance vs Drain to Source Voltage.</p>
<p>Figure 9: Unclamped Inductive Switching Capability.</p>	<p>Figure 10: Maximum Continuous Drain Current vs Ambient Temperature.</p>
<p>Figure 11: Forward Bias Safe Operating Area.</p>	<p>Figure 12: Single Pulse Maximum Power Dissipation.</p>



7.3 Typical Characteristics

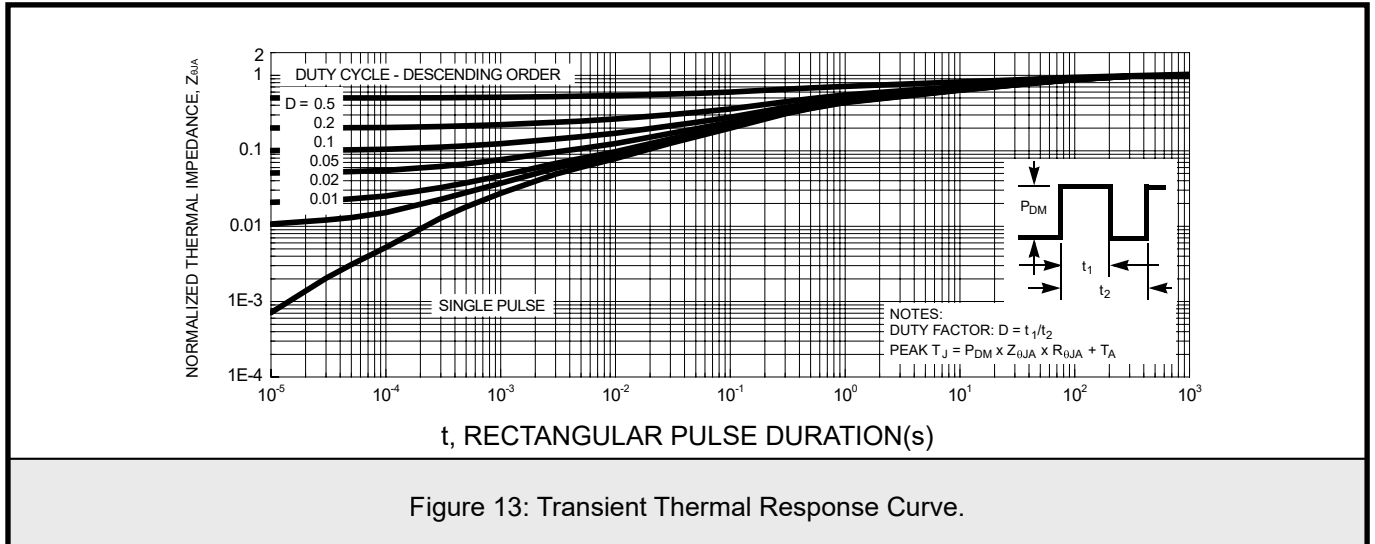



8.SOP-8 Package Outline Dimensions

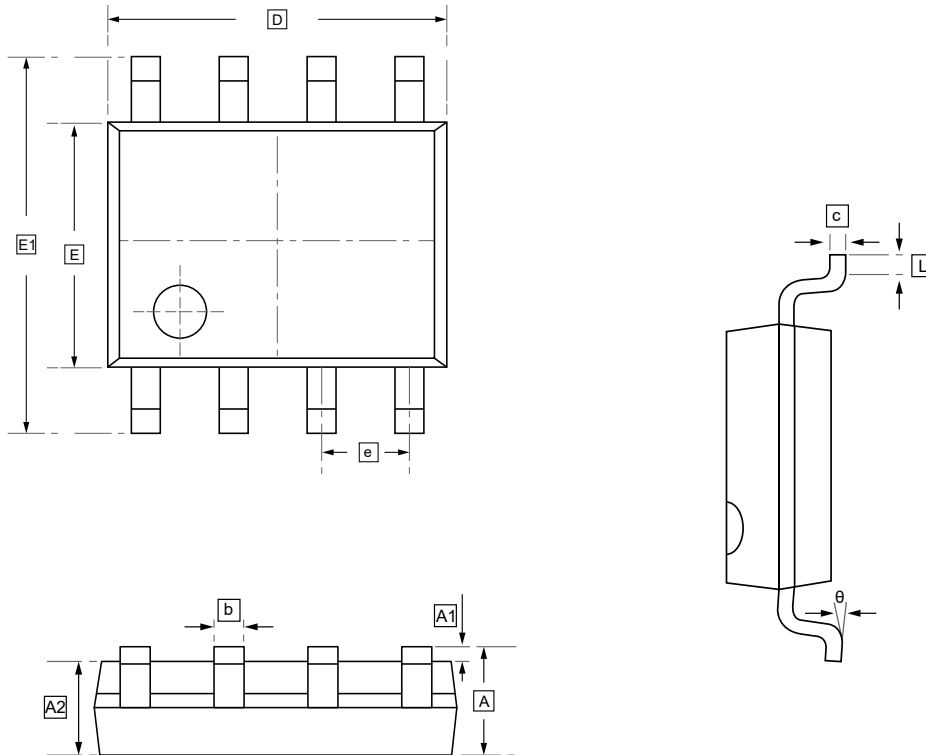

DIMENSIONS (mm are the original dimensions)

Symbol	A	A1	A2	b	c	D	E	E1	e	L	θ
Min	1.350	0.000	1.350	0.330	0.170	4.700	3.800	5.800	1.270	0.400	0°
Max	1.750	0.100	1.550	0.510	0.250	5.100	4.000	6.200	BSC	1.270	8°



9. Ordering information

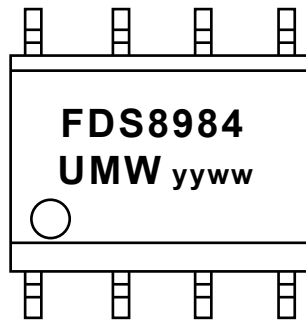

yy: Year Code
ww: Week Code

Order Code	Package	Base QTY	Delivery Mode
UMW FDS8984	SOP-8	3000	Tape and reel



10. Disclaimer

UMW reserves the right to make changes to all products, specifications. Customers should obtain the latest version of product documentation and verify the completeness and currency of the information before placing an order.

When applying our products, please do not exceed the maximum rated values, as this may affect the reliability of the entire system. Under certain conditions, any semiconductor product may experience faults or failures. Buyers are responsible for adhering to safety standards and implementing safety measures during system design, prototyping, and manufacturing when using our products to prevent potential failure risks that could lead to personal injury or property damage.

Unless explicitly stated in writing, UMW products are not intended for use in medical, life-saving, or life-sustaining applications, nor for any other applications where product failure could result in personal injury or death. If customers use or sell the product for such applications without explicit authorization, they assume all associated risks.

When reselling, applying, or exporting, please comply with export control laws and regulations of China, the United States, the United Kingdom, the European Union, and other relevant countries, regions, and international organizations.

This document and any actions by UMW do not grant any intellectual property rights, whether express or implied, by estoppel or otherwise. The product names and marks mentioned herein may be trademarks of their respective owners.