

M62001L/FP to M62008L/FP

Low Power 2 Output System Reset IC Series

REJ03D0781-0100

Rev.1.00

Sep 14, 2005

Description

The M62001 to M62008 are semiconductor integrated circuits whose optimum use is for the detection of the rise and fall in the power supply to a microcomputer system in order to reset or release the microcomputer system.

The M62001 to M62008 carry out voltage detection in two-steps and have two output pins. As Bi-CMOS process and low power dissipating circuits are employed, they output optimum signals through each output pin to a system that requires RAM backup. As output signals, interruption ($\overline{\text{INT}}$) and compulsive reset ($\overline{\text{RESET}}$) signals are available. The interruption signal ($\overline{\text{INT}}$) is used to alter the microcomputer from normal mode to backup mode and vice versa. These output signals are classified into pulse type (M62001 to M62004) and hold type (M62005 to M62008).

Features

- Bi-CMOS process realizes a configuration of low current dissipating circuits.

Circuit current

$I_{CC} = 5 \mu\text{A}$ (Typ, normal mode, $V_{CC} = 5.0 \text{ V}$)

$I_{CC} = 1 \mu\text{A}$ (Typ, backup mode, $V_{CC} = 2.5 \text{ V}$)

- Two-step detection of supply voltage

Detection voltage in normal mode (2 types)

$V_S = 4.45 \text{ V}/4.25 \text{ V}$ (Typ)

Detection voltage in backup mode

$V_{BATT} = 2.15 \text{ V}$ (Typ)

- Two outputs

Reset output ($\overline{\text{RESET}}$): output of compulsive reset signal

Interruption output ($\overline{\text{INT}}$): output of interruption signal

- Two types of output forms: CMOS and open drain

- Two types of interruption output ($\overline{\text{INT}}$) signals

Pulse type (M62001 to M62004)

Hold type (M62005 to M62008)

- Two types of outline packages

5-pin plastic SIP (single in-line package)

8-pin plastic SOP (mini flat package)

- Output based on RAM backup mode (see the timing chart)

Application

- Prevention of errors in microcomputer system in electronic equipment that requires RAM backup, such as office, industrial, and home-use equipment.

Pin Arrangement

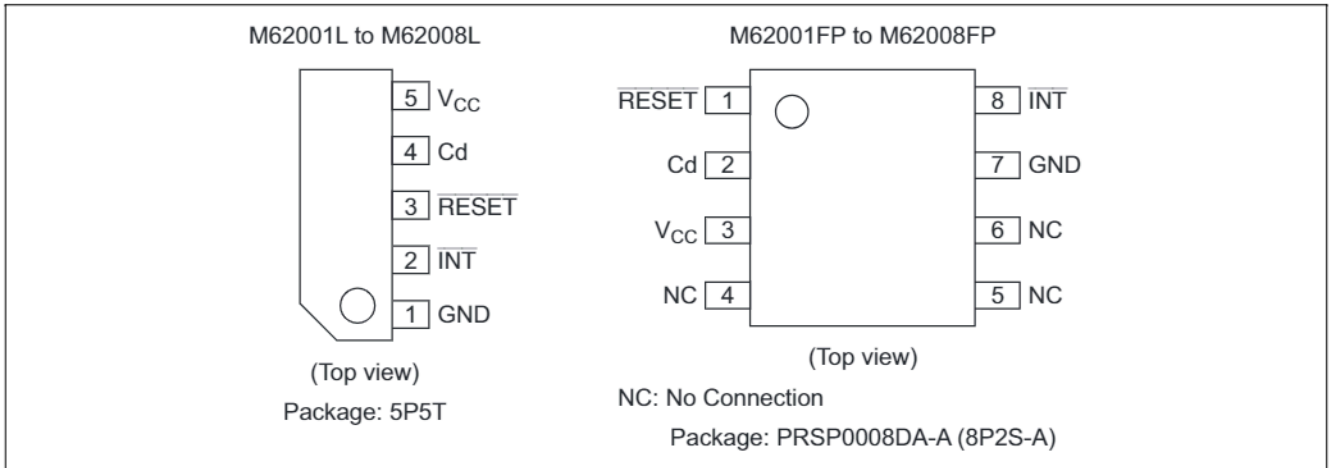

Block Diagram

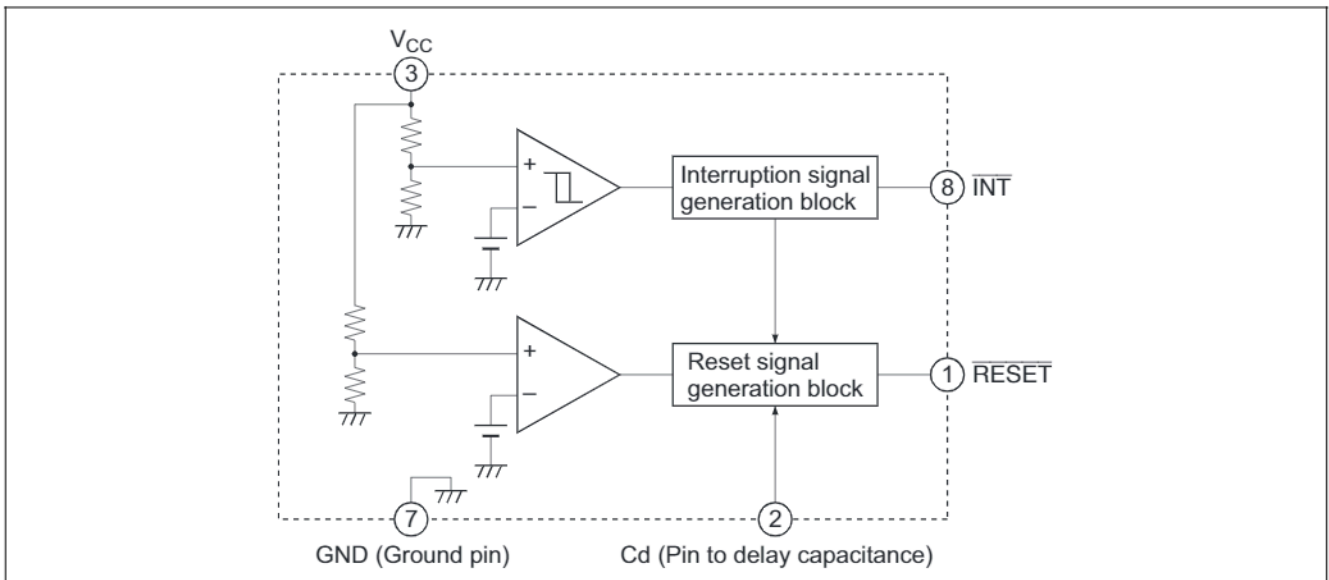

Absolute Maximum Ratings

(Ta = 25°C, unless otherwise noted)

Item	Symbol	Ratings	Unit	Conditions
Supply voltage	V _{CC}	8	V	
Output sink current	I _{sink}	5	mA	
Power dissipation	P _d	440	mW	
Thermal derating	K _θ	4.4	mW/°C	Ta ≥ 25°C
Operating temperature	T _{opr}	-20 to +75	°C	
Storage temperature	T _{stg}	-40 to +125	°C	

Electrical Characteristics

(Ta = 25°C, unless otherwise noted)

Item	Symbol	Min	Typ	Max	Unit	Test Conditions
Supply voltage	V _S	4.30	4.45	4.60	V	Interruption level during V _{CC} drop (Equivalent to V _{SL})
		4.05	4.25	4.45		
Battery voltage	V _{BATT}	2.00	2.15	2.30		Reset level at backup
Hysteresis voltage	ΔV _S	—	100	—	mV	ΔV _S = V _{SH} - V _{SL}
Circuit current	I _{CC}	—	5.0	20	μA	V _{CC} = 5.0V: in normal mode
		—	1.0	4		V _{CC} = 2.5V: in backup mode
Sink ability	V _{sat1}	—	0.2	0.4	V	V _{CC} = 4V, I _o = 4mA (Output saturation voltage of N-ch transistor)
Source ability	V _{sat2}	—	0.2	0.4		V _{CC} = 4V, I _o = 1mA (Output saturation voltage of P-ch transistor) [CMOS output] M62001, M62003, M62005, M62007
Delay time	t _d	—	50	—	ms	External capacitance C _d = 0.33μF
Pulse width	t _{pw}	—	7	10	μs	Output pulse width (M62001, M62002, M62003, M62004)
Reset output response time	t _{RESET}	—	30	—	μs	Time between V _{CC} (when falling) = V _{BATT} and output of $\overline{\text{RESET}}$ signal
Interruption output reset time	t _{INT}	—	100	—	μs	Time between V _{CC} (when falling) = V _S and output of $\overline{\text{INT}}$ signal

Summary of M62001L/FP to M62008L/FP

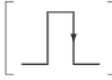
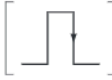
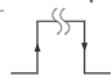
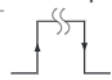
Type No.	Supply Voltage Detection Level V _S (V)	Battery Voltage Detection Level V _{BATT} (V)	Output Form	Interruption Signal Output Mode
M62001L/FP	4.45	2.15	CMOS	Pulse output 
M62002L/FP			Open drain	
M62003L/FP	4.25	2.15	CMOS	Pulse output 
M62004L/FP			Open drain	
M62005L/FP	4.45	2.15	CMOS	Hold output 
M62006L/FP			Open drain	
M62007L/FP	4.25	2.15	CMOS	Hold output 
M62008L/FP			Open drain	

Typical Characteristics

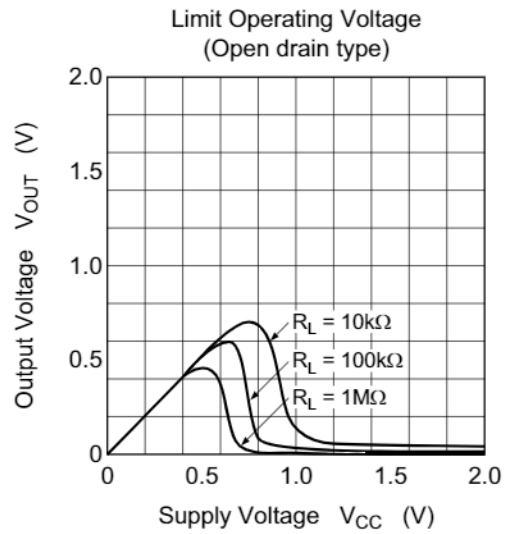
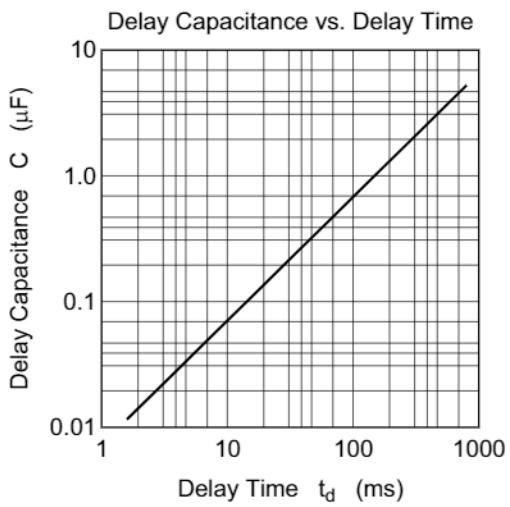
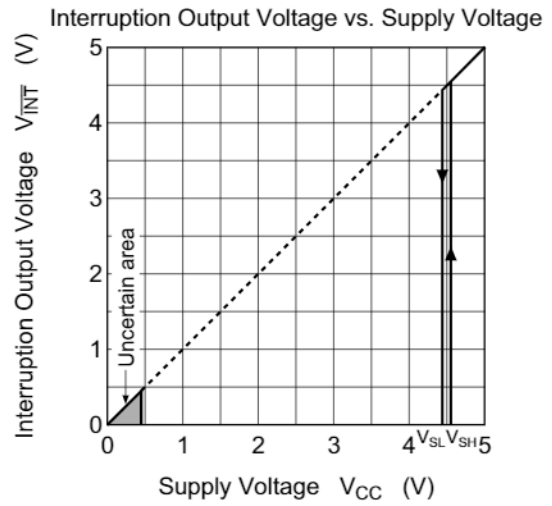
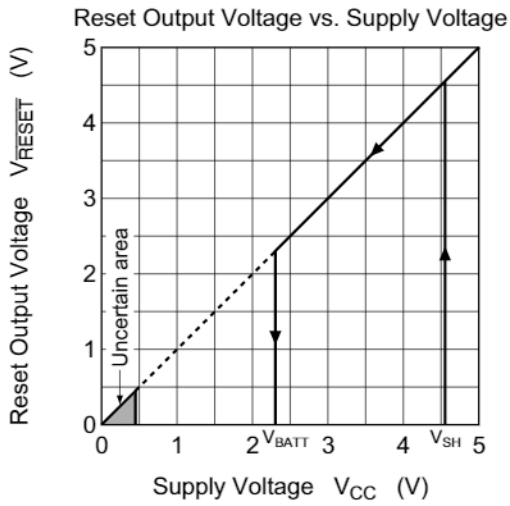
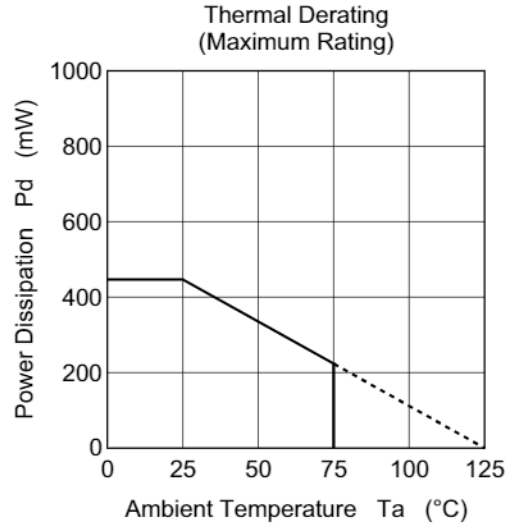
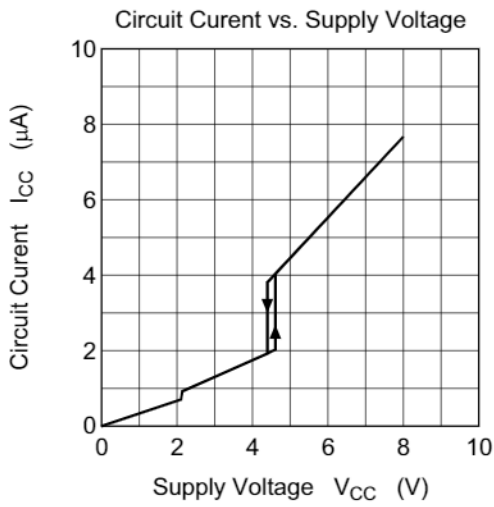

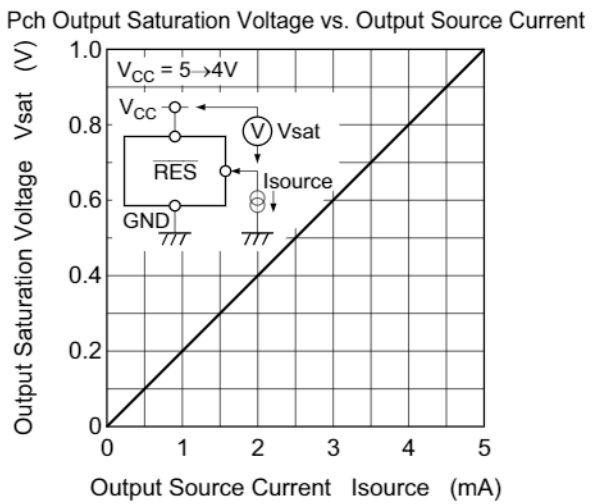
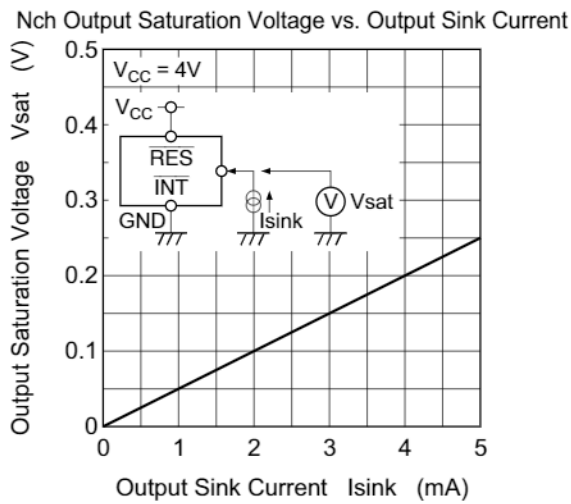
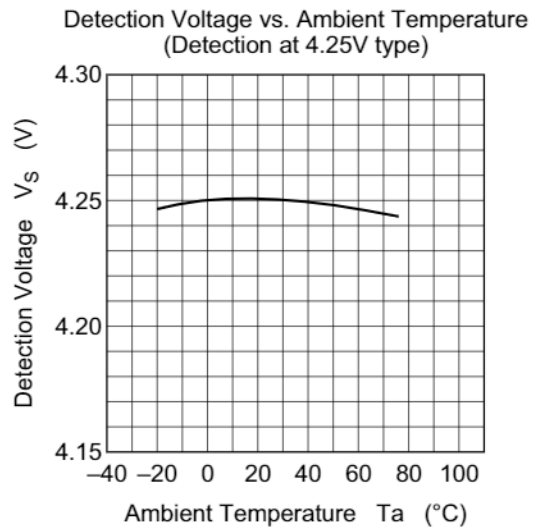
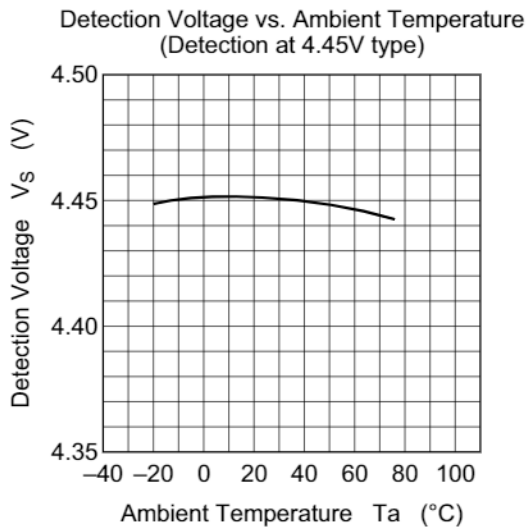
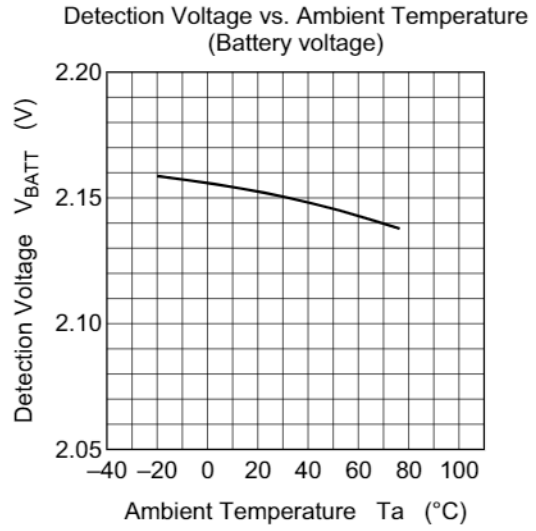
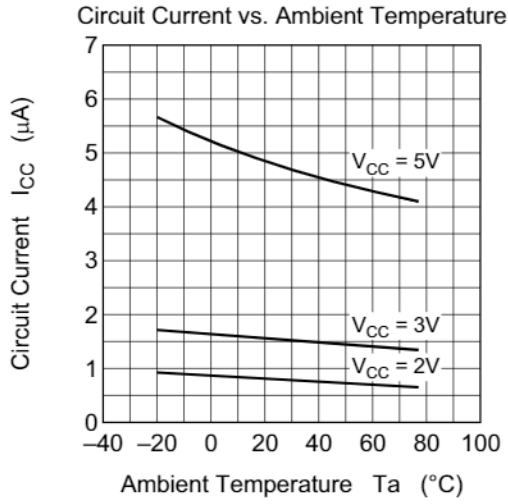

Operating Principle

Description

In general, the memory backup function of a microcomputer, as shown in figure 1, uses two diodes to switch between main power supply and backup power supply. The M62001 to M62008 are ICs that, in such memory backup operation, monitor in two steps each voltage on the V_{DD} line.

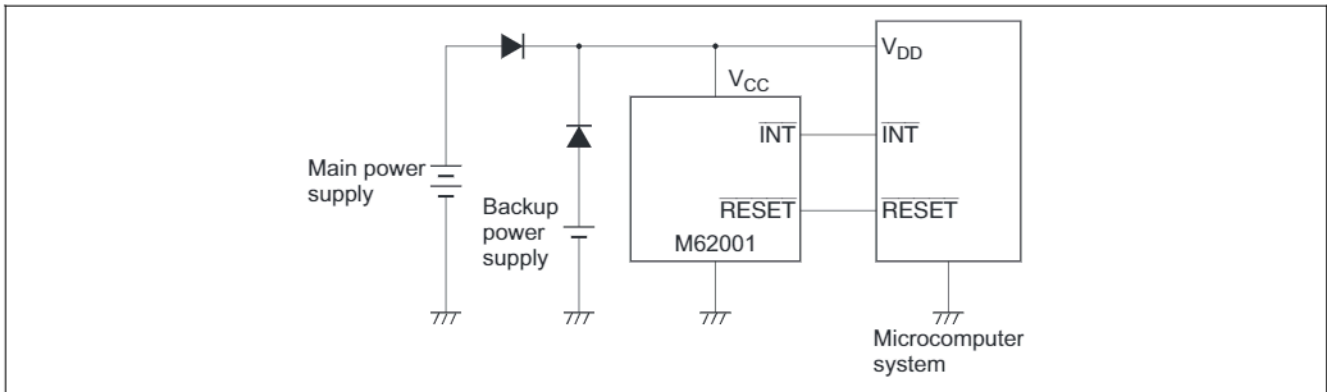

Figure 1

The ICs have an intelligent sequence such as substantial hysteresis action of $\overline{\text{RESET}}$ toward normal state at restoration of supply voltage, as well as two-step detection in low power dissipation mode.

Detailed Description

1. Two-step detection

The ICs perform two-step detection of supply voltage and have two output pins ($\overline{\text{INT}}$ and $\overline{\text{RESET}}$). Although they have two comparators for two-step detection, they differ significantly from such that are simply provided with independent detectors, because the $\overline{\text{RESET}}$ output signal is dependent at power-up and the like upon the $\overline{\text{INT}}$ output signal.

2. $\overline{\text{INT}}$ output (Detection of 4.45 V and 4.25 V)

The $\overline{\text{INT}}$ output at the power-up of supply voltage detects V_{SH} (4.45 V/4.25 V) to inform the microcomputer system of the fact that the supply voltage has reached its normal level. When the supply voltage drops from its normal level to V_{SL} (4.45 V/4.25 V) an interruption signal is output to alter the microcomputer system into RAM backup mode. The microcomputer at this point enters sleep state and secures memory by a stop command issued by the interruption signal. These detection voltage, V_{SH} the rise, and V_{SL} the fall, of supply voltage, have a 100 mV hysteresis voltage between themselves.

$$V_{SH} - V_{SL} \approx 100 \text{ (mV)}$$

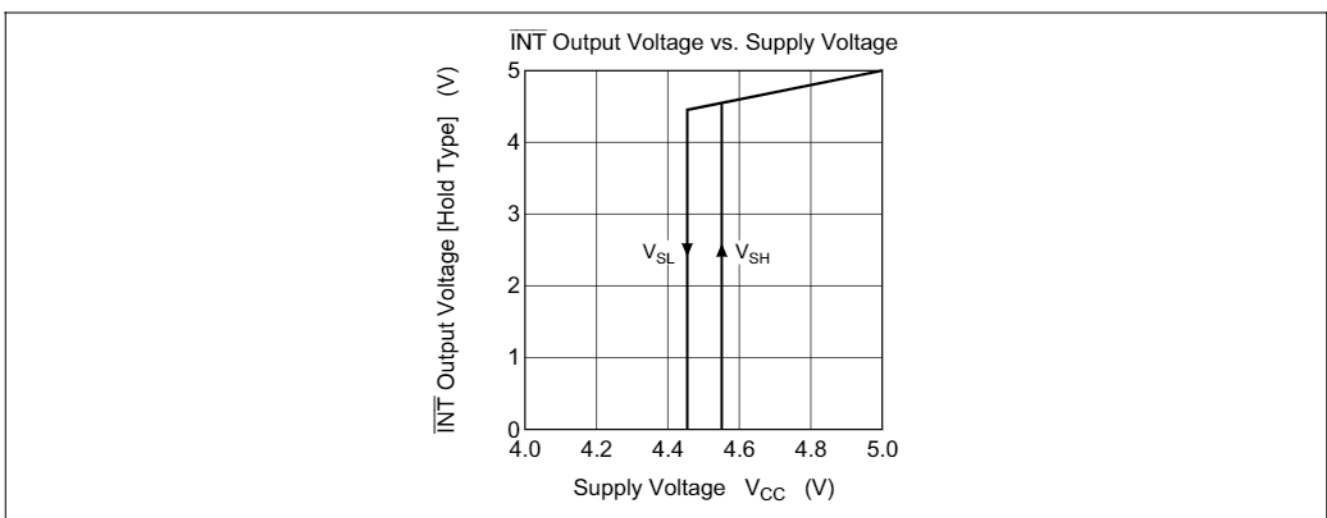

Figure 2 $\overline{\text{INT}}$ Output (Detection of 4.45 V and 4.25 V)

3. $\overline{\text{RESET}}$ output (Detection of 2.15 V)

The $\overline{\text{RESET}}$ outputs a signal to prevent the microcomputer from malfunctioning due to a drop in supply voltage. When powering up, $\overline{\text{RESET}}$ is kept at low level until the supply voltage reaches V_{SH} . If the supply voltage rises to V_{SH} , $\overline{\text{RESET}}$ is set to high level. By inserting a capacitor between the Cd pin and GND, it is possible to produce a desired delay time (t_d). To set a delay time, equation below is used.

$$t_d \approx 1.52 \times 10^5 \times C \text{ (s)}$$

Once the supply voltage has exceeded V_{SH} and the $\overline{\text{RESET}}$ output is set to high level, $\overline{\text{RESET}}$ maintains the high level until the supply voltage drops to V_{BATT} . When the supply voltage drops to V_{BATT} , $\overline{\text{RESET}}$ goes low thereby resetting and initializing the microcomputer.

The $\overline{\text{RESET}}$ output has a large hysteresis voltage of approximately 2 V between the rise in supply voltage at power-up and its fall.

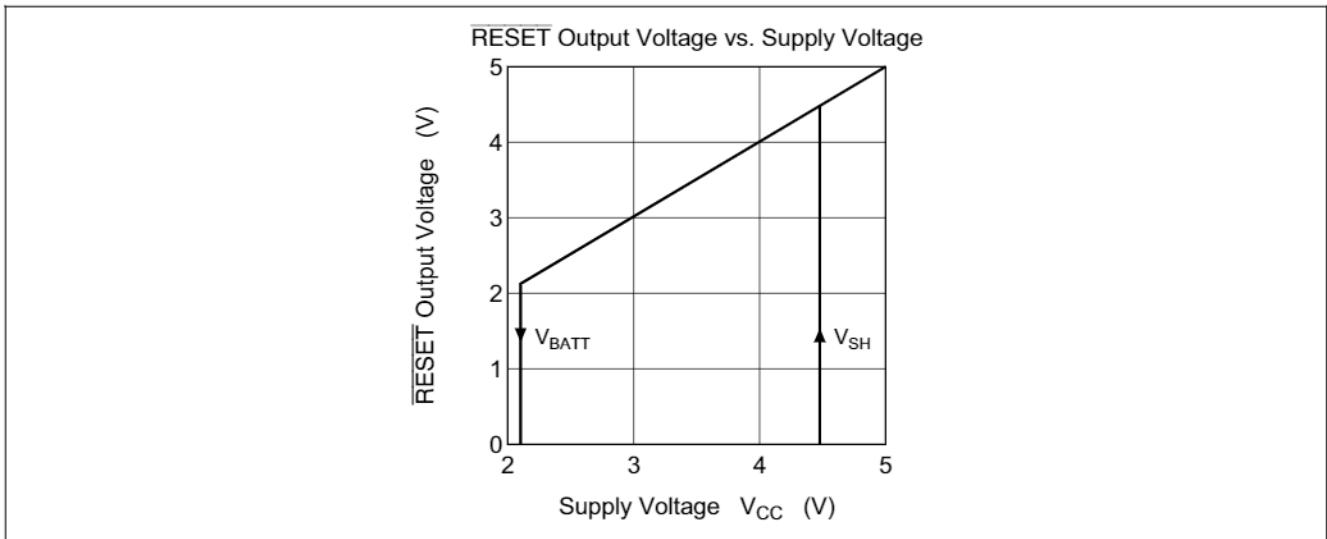

Figure 3 $\overline{\text{RESET}}$ Output (Detection of 2.15 V)

Operating Description

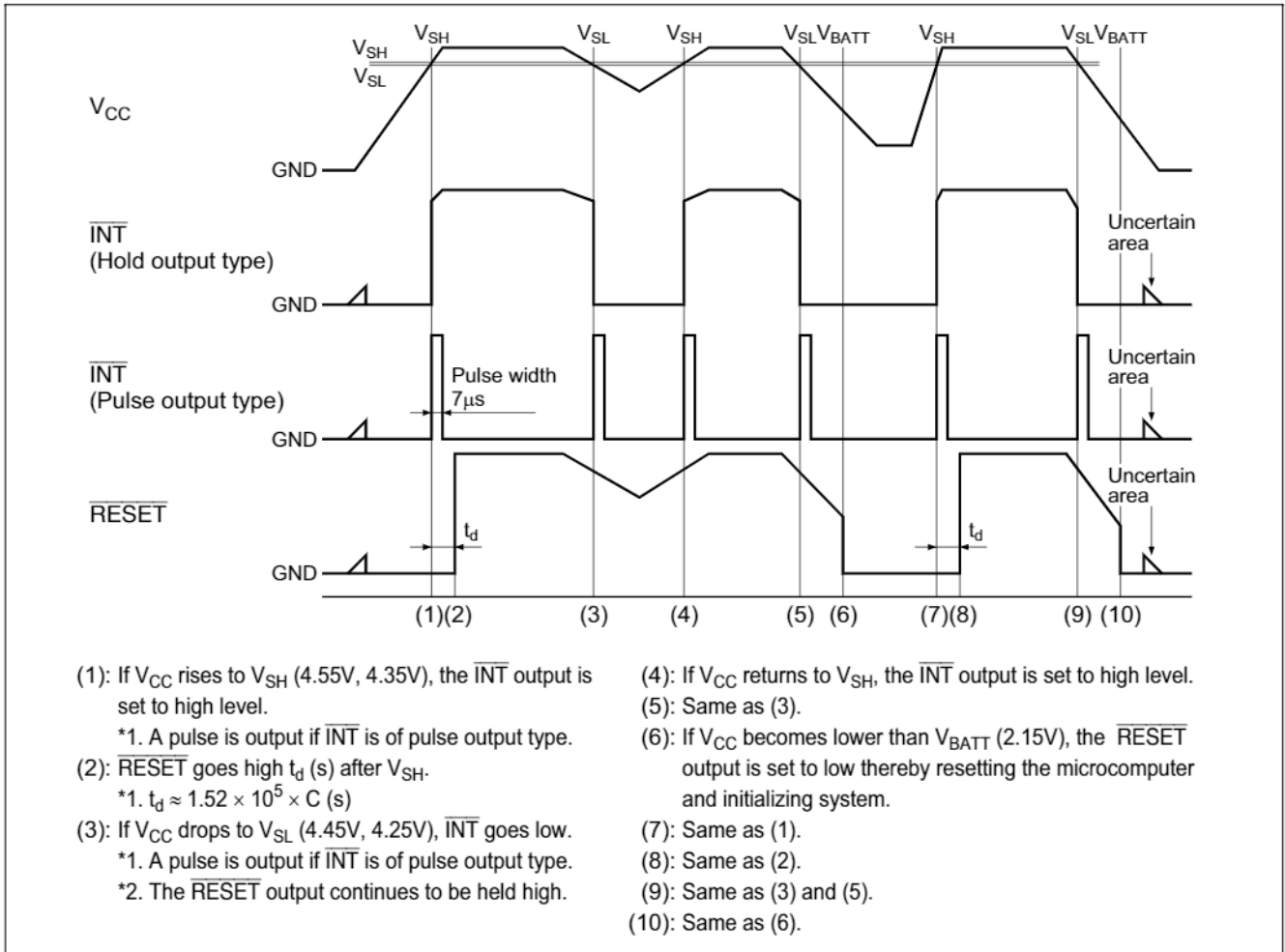

Figure 4 Operating Waveform

Application Example

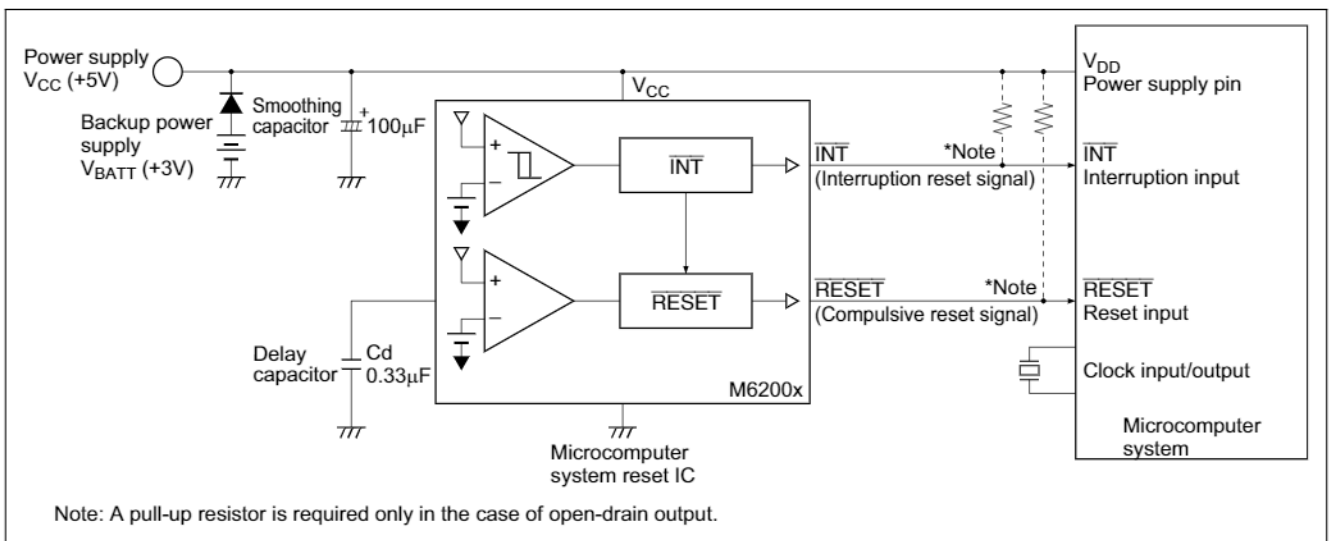
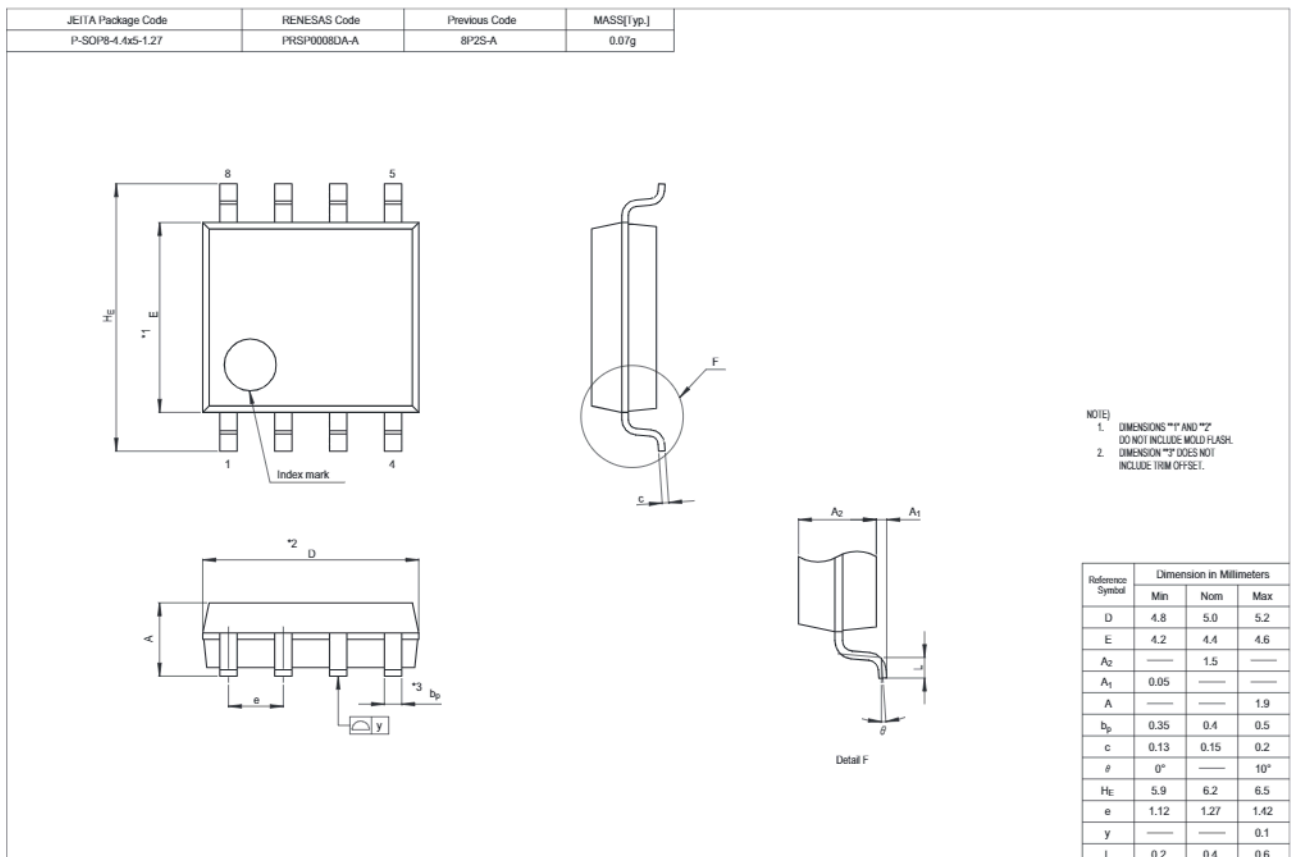
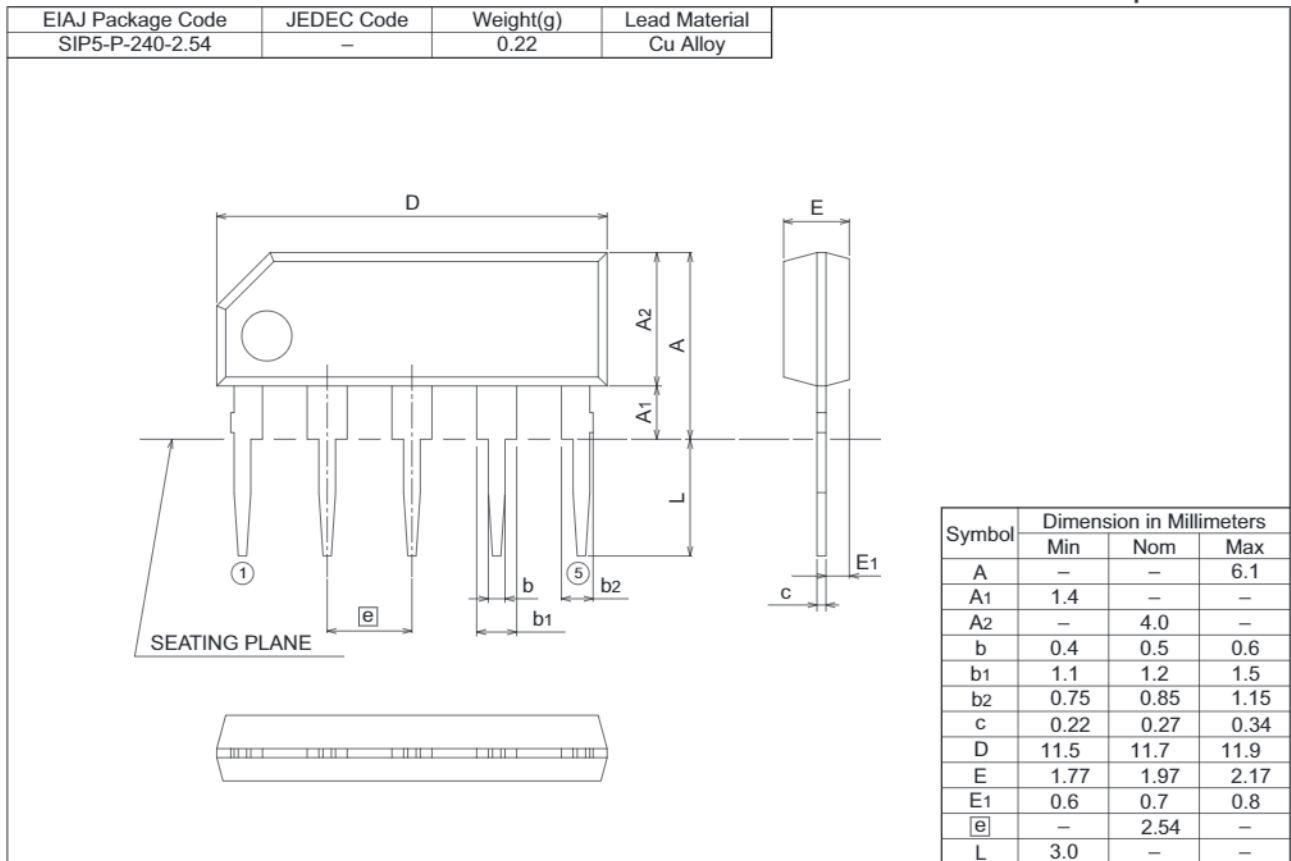

Figure 5 Application Example

Package Dimensions

5P5T

Plastic 5pin 240mil SIP



RENESAS Technology Corp. Sales Strategic Planning Div. Nippon Bldg., 2-6-2, Ohte-machi, Chiyoda-ku, Tokyo 100-0004, Japan

Keep safety first in your circuit designs!

1. Renesas Technology Corp. puts the maximum effort into making semiconductor products better and more reliable, but there is always the possibility that trouble may occur with them. Trouble with semiconductors may lead to personal injury, fire or property damage.
Remember to give due consideration to safety when making your circuit designs, with appropriate measures such as (i) placement of substitutive, auxiliary circuits, (ii) use of nonflammable material or (iii) prevention against any malfunction or mishap.

Notes regarding these materials

1. These materials are intended as a reference to assist our customers in the selection of the Renesas Technology Corp. product best suited to the customer's application; they do not convey any license under any intellectual property rights, or any other rights, belonging to Renesas Technology Corp. or a third party.
2. Renesas Technology Corp. assumes no responsibility for any damage, or infringement of any third-party's rights, originating in the use of any product data, diagrams, charts, programs, algorithms, or circuit application examples contained in these materials.
3. All information contained in these materials, including product data, diagrams, charts, programs and algorithms represents information on products at the time of publication of these materials, and are subject to change by Renesas Technology Corp. without notice due to product improvements or other reasons. It is therefore recommended that customers contact Renesas Technology Corp. or an authorized Renesas Technology Corp. product distributor for the latest product information before purchasing a product listed herein.
The information described here may contain technical inaccuracies or typographical errors.
Renesas Technology Corp. assumes no responsibility for any damage, liability, or other loss rising from these inaccuracies or errors.
Please also pay attention to information published by Renesas Technology Corp. by various means, including the Renesas Technology Corp. Semiconductor home page (<http://www.renesas.com>).
4. When using any or all of the information contained in these materials, including product data, diagrams, charts, programs, and algorithms, please be sure to evaluate all information as a total system before making a final decision on the applicability of the information and products. Renesas Technology Corp. assumes no responsibility for any damage, liability or other loss resulting from the information contained herein.
5. Renesas Technology Corp. semiconductors are not designed or manufactured for use in a device or system that is used under circumstances in which human life is potentially at stake. Please contact Renesas Technology Corp. or an authorized Renesas Technology Corp. product distributor when considering the use of a product contained herein for any specific purposes, such as apparatus or systems for transportation, vehicular, medical, aerospace, nuclear, or undersea repeater use.
6. The prior written approval of Renesas Technology Corp. is necessary to reprint or reproduce in whole or in part these materials.
7. If these products or technologies are subject to the Japanese export control restrictions, they must be exported under a license from the Japanese government and cannot be imported into a country other than the approved destination.
Any diversion or reexport contrary to the export control laws and regulations of Japan and/or the country of destination is prohibited.
8. Please contact Renesas Technology Corp. for further details on these materials or the products contained therein.



RENESAS SALES OFFICES

<http://www.renesas.com>

Refer to "<http://www.renesas.com/en/network>" for the latest and detailed information.

Renesas Technology America, Inc.

450 Holger Way, San Jose, CA 95134-1368, U.S.A
Tel: <1> (408) 382-7500, Fax: <1> (408) 382-7501

Renesas Technology Europe Limited

Dukes Meadow, Millboard Road, Bourne End, Buckinghamshire, SL8 5FH, U.K.
Tel: <44> (1628) 585-100, Fax: <44> (1628) 585-900

Renesas Technology Hong Kong Ltd.

7th Floor, North Tower, World Finance Centre, Harbour City, 1 Canton Road, Tsimshatsui, Kowloon, Hong Kong
Tel: <852> 2265-6688, Fax: <852> 2730-6071

Renesas Technology Taiwan Co., Ltd.

10th Floor, No.99, Fushing North Road, Taipei, Taiwan
Tel: <886> (2) 2715-2888, Fax: <886> (2) 2713-2999

Renesas Technology (Shanghai) Co., Ltd.

Unit2607 Ruijing Building, No.205 Maoming Road (S), Shanghai 200020, China
Tel: <86> (21) 6472-1001, Fax: <86> (21) 6415-2952

Renesas Technology Singapore Pte. Ltd.

1 Harbour Front Avenue, #06-10, Keppel Bay Tower, Singapore 098632
Tel: <65> 6213-0200, Fax: <65> 6278-8001

Renesas Technology Korea Co., Ltd.

Kukje Center Bldg. 18th Fl., 191, 2-ka, Hangang-ro, Yongsan-ku, Seoul 140-702, Korea
Tel: <82> 2-796-3115, Fax: <82> 2-796-2145

Renesas Technology Malaysia Sdn. Bhd.

Unit 906, Block B, Menara Amcorp, Amcorp Trade Centre, No.18, Jalan Persiaran Barat, 46050 Petaling Jaya, Selangor Darul Ehsan, Malaysia
Tel: <603> 7955-9390, Fax: <603> 7955-9510