

Product Summary

- V_{DS} -30 V
- I_{DS} -3.5A
- $R_{DS(ON)}$ (at $V_{GS}=-10V$) <88m Ω
- $R_{DS(ON)}$ (at $V_{GS}=-4.5V$) <138m Ω

Application

- Battery protection
- Load switch
- Power management
- DC/DC converter

Package and Pin Configuration

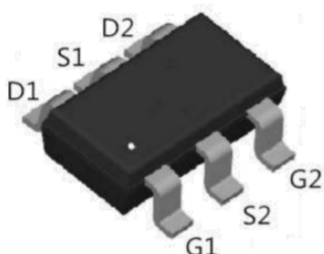

Circuit diagram

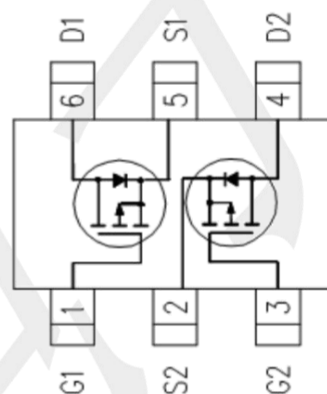

Marking: 2623

Absolute Maximum Ratings (T_c=25°C unless otherwise noted)

PARAMETER	SYMBOL	LIMIT	UNIT
Drain-Source Voltage	V_{DS}	-30	V
Gate-Source Voltage	V_{GS}	±20	V
Continuous Drain Current	I_D	-3.5	A
Pulsed Drain Current (note 1)	I_{DM}	-12	A
Total Power Dissipation (note 2)	P_{DTOT}	1.8	W
Operating Junction Temperature Range	T_J	-55 to +150	°C
Storage Temperature Range	T_{stg}	-55 to +150	°C

Notes : 1. Pulse width limited by Max.junction temperature.

2. Per element must not be exceeded

Thermal Characteristic

PARAMETER	Symbol	Value	Unit
Junction-to-Ambient Thermal Resistance PCB Mount (Note)	R_{thJA}	115	°C/W

Note : When mounted on 1" square PCB (FR4 material).

Electrical Characteristics (T_A=25 °C unless otherwise noted)

PARAMETER	CONDITIONS	SYMBOL	MIN	TYP	MAX	UNIT
Static						
Drain-Source Breakdown Voltage	V _{GS} =0V, I _D = -250μA	BV _{DSS}	-30	--	--	V
Gate-Source Threshold Voltage	V _{DS} =V _{GS} , I _D = -250μA	V _{GS(th)}	-1	-2	-3	V
Gate-Source Leakage	V _{DS} =0V, V _{GS} = ±20V	I _{GSS}	--	--	±100	nA
Zero Gate Voltage Drain Current	V _{DS} = -30V, V _{GS} =0V	I _{DSS}	--	--	-1	μA
	V _{DS} = -30V, T _J =55°C		--	--	-10	μA
Drain-Source On-State Resistance (Note 1)	V _{GS} = -10V, I _D = -3.5A	R _{DS(on)}	--	77	88	mΩ
	V _{GS} = -4.5V, I _D = -2.5A		--	110	138	
Forward Transconductance (Note 2)	V _{DS} = -10V, I _D = -3.5A	g _{fs}	--	7	--	S
Dynamic (Note 2)						
Total Gate Charge (Note 3)	V _{DS} = -15V, I _D = -2.5A, V _{GS} = -4.5V	Q _g	--	4.1	--	nC
Gate-Source Charge (Note 3)		Q _{gs}	--	1.3	--	
Gate-Drain Charge (Note 3)		Q _{gd}	--	1.8	--	
Input Capacitance	V _{DS} = -15V, V _{GS} = 0V, F= 1.0MHz	C _{iss}	--	340	--	pF
Output Capacitance		C _{oss}	--	67	--	
Reverse Transfer Capacitance		C _{rss}	--	51	--	
Switching						
Turn-On Delay Time (Note 3)	V _{DD} = -15V, I _D = -1A, V _{GEN} = -4.5V, R _L = 15Ω, R _G = 1Ω	t _{d(on)}	--	40	--	nS
Rise Time (Note 3)		t _r	--	40	--	
Turn-Off Delay Time (Note 3)		t _{d(off)}	--	20	--	
Fall Time (Note 3)		t _f	--	17	--	
Source-Drain Diode Ratings and Characteristics (Note 2)						
Forward Voltage	V _{GS} = 0V, I _F = -0.75A	V _{SD}	--	-0.8	-1.2	V
Continuous Source Current	Integral reverse diode in the MOSFET	I _S	--	--	-1.5	A
Pulsed Current (Note 1)		I _{SM}	--	--	-12	A

Notes:

1. Pulse test; pulse width ≤ 300 μs, duty cycle ≤ 2%.
2. Guaranteed by design, not subject to production testing.
3. Independent of operating temperature

TYPICAL CHARACTERISTICS (25 °C, unless otherwise noted)

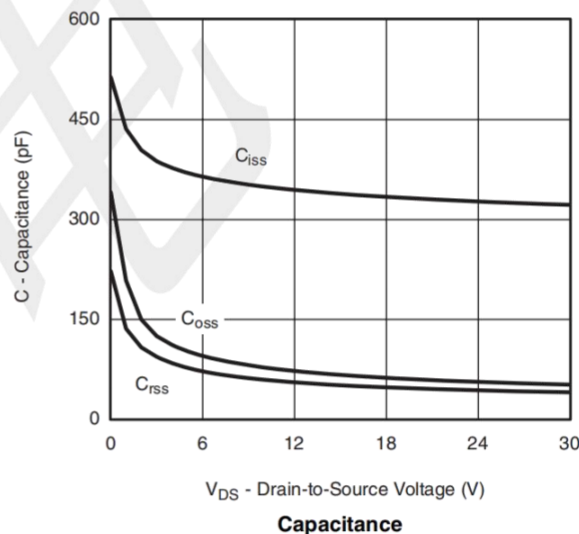
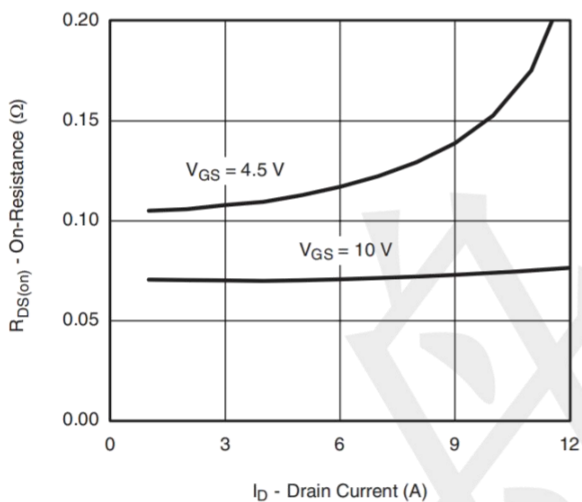
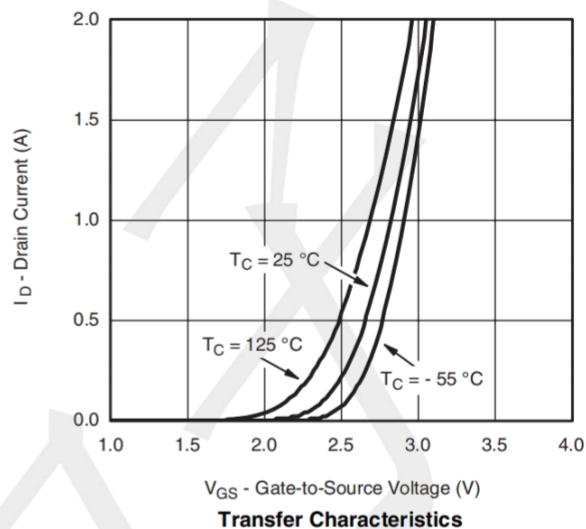
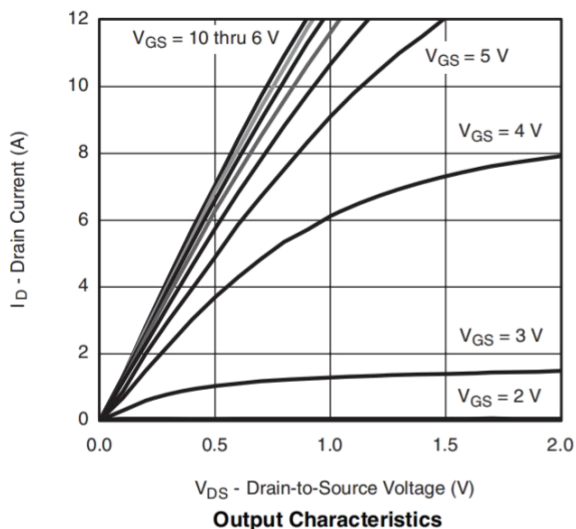

On-Resistance vs. Drain Current and Gate Voltage

Capacitance

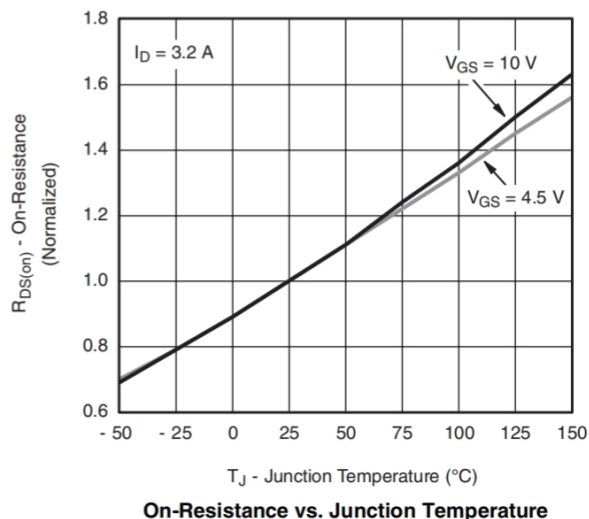
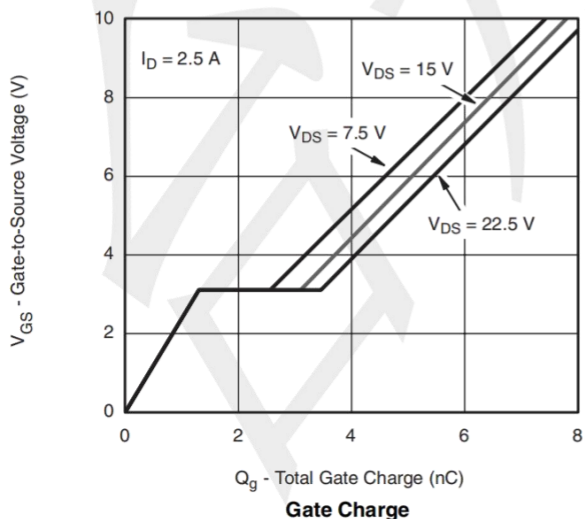

On-Resistance vs. Junction Temperature

Package Outline & Dimensions

SOT23-6L

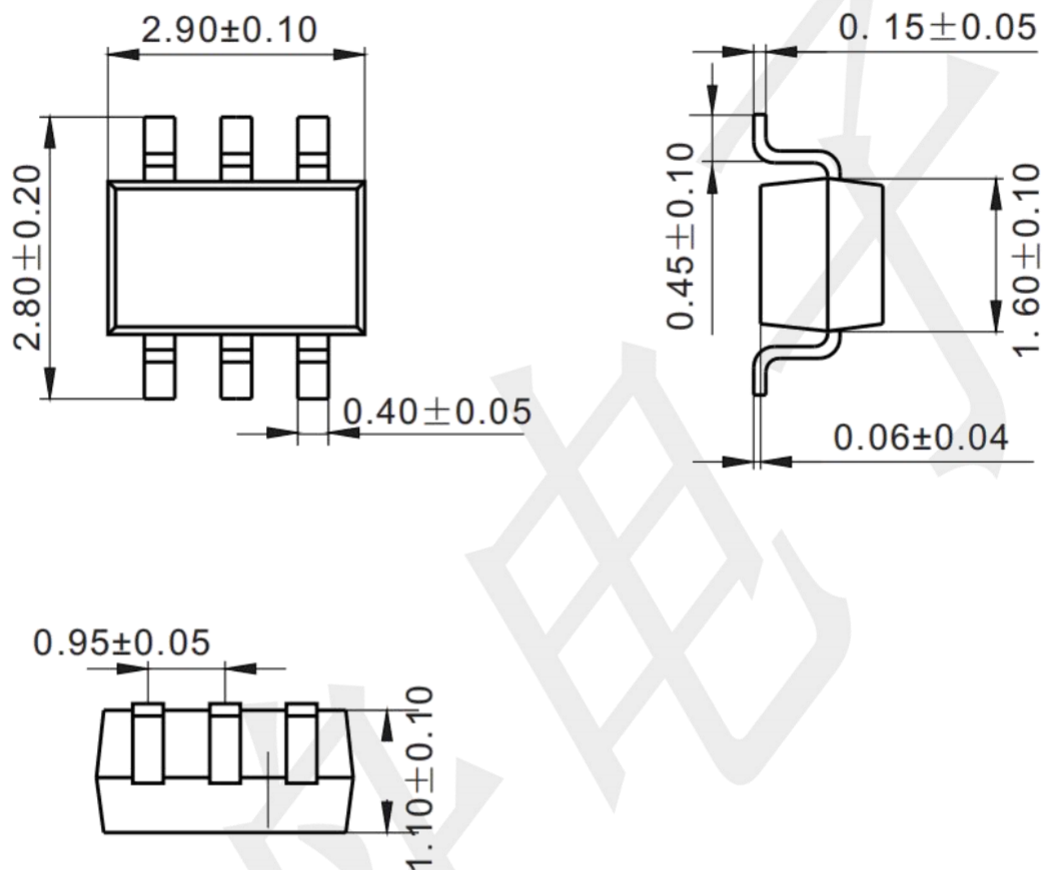

Mounting Pad Layout (unit: mm)

