



P-Ch 100V Fast Switching MOSFETs

Applications

- High Frequency Switching and Synchronous Rectification.
- DC/DC Converters.
- Power Tool Application.

- 100% EAS Guaranteed
- Green Device Available
- Fast Switching Speed
- Advanced high cell density Trench technology

Product Summary

V_{DS}	-100	V
$R_{DS(ON),typ}$	17	m Ω
I_D	-60	A

TO-252 Pin Configuration

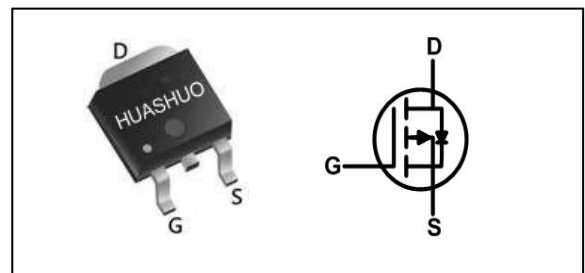

Absolute Maximum Ratings

Symbol	Parameter	Rating	Units
V_{DS}	Drain-Source Voltage	-100	V
V_{GS}	Gate-Source Voltage	± 20	V
$I_D@T_C=25^\circ C$	Continuous Drain Current, $V_{GS} @ -10V^1$	-60	A
$I_D@T_C=100^\circ C$	Continuous Drain Current, $V_{GS} @ -10V^1$	-35	A
$I_D@T_A=25^\circ C$	Continuous Drain Current, $V_{GS} @ -10V^1$	-7.8	A
$I_D@T_A=100^\circ C$	Continuous Drain Current, $V_{GS} @ -10V^1$	-6.1	A
I_{DM}	Pulsed Drain Current ²	-180	A
EAS	Single Pulse Avalanche Energy ³	370	mJ
I_{AS}	Avalanche Current	-86	A
$P_D@T_C=25^\circ C$	Total Power Dissipation ⁴	105	W
T_{STG}	Storage Temperature Range	-55 to 150	$^\circ C$
T_J	Operating Junction Temperature Range	-55 to 150	$^\circ C$

Thermal Data

Symbol	Parameter	Typ.	Max.	Unit
$R_{\theta JA}$	Thermal Resistance Junction-Ambient ¹	---	50	$^\circ C/W$
$R_{\theta JC}$	Thermal Resistance Junction-Case ¹	---	1.2	$^\circ C/W$



P-Ch 100V Fast Switching MOSFETs

Electrical Characteristics (T_J=25 °C, unless otherwise noted)

Symbol	Parameter	Conditions	Min.	Typ.	Max.	Unit
BV _{DSS}	Drain-Source Breakdown Voltage	V _{GS} =0V, I _D =-250uA	-100	---	---	V
R _{DS(ON)}	Static Drain-Source On-Resistance ²	V _{GS} =-10V, I _D =-20A	---	17	20	mΩ
V _{GS(th)}	Gate Threshold Voltage	V _{GS} =V _{DS} , I _D =-250uA	-2.0	-2.8	-4.0	V
I _{DSS}	Drain-Source Leakage Current	V _{DS} =-80V, V _{GS} =0V, T _J =25°C	---	---	-1	uA
I _{GSS}	Gate-Source Leakage Current	V _{GS} =±20V, V _{DS} =0V	---	---	±100	nA
R _g	Gate Resistance	V _{DS} =-0V, V _{GS} =0V, f=1MHz	---	4.2	---	Ω
Q _g	Total Gate Charge	V _{DS} =-50V, V _{GS} =-10V, I _D =-20A	---	52	---	nC
Q _{gs}	Gate-Source Charge		---	14	---	
Q _{gd}	Gate-Drain Charge		---	13	---	
T _{d(on)}	Turn-On Delay Time	V _{DD} =-50V, V _{GS} =-10V, R _G =3.3Ω, I _D =-20A	---	17	---	ns
T _r	Rise Time		---	42	---	
T _{d(off)}	Turn-Off Delay Time		---	46	---	
T _f	Fall Time		---	42	---	
C _{iss}	Input Capacitance	V _{DS} =-25V, V _{GS} =0V, f=1MHz	---	3250	---	pF
C _{oss}	Output Capacitance		---	1423	---	
C _{rss}	Reverse Transfer Capacitance		---	95	---	

Diode Characteristics

Symbol	Parameter	Conditions	Min.	Typ.	Max.	Unit
I _S	Continuous Source Current ^{1,5}	V _G =V _D =0V, Force Current	---	---	-60	A
V _{SD}	Diode Forward Voltage ²	V _{GS} =0V, I _S =-1A, T _J =25°C	---	---	1.2	V
t _{rr}	Reverse Recovery Time	I _F =-20A, di/dt=-100A/μs, T _J =25°C	---	91	---	nS
Q _{rr}	Reverse Recovery Charge		---	355	---	nC

Note :

- 1.The data tested by surface mounted on a 1 inch² FR-4 board with 2OZ copper.
- 2.The data tested by pulsed , pulse width ≤ 300us , duty cycle ≤ 2%
- 3.The EAS data shows Max. rating . The test condition is V_{DD}=-25V,V_{GS}=-10V,L=0.1mH,I_{AS}=-86A
- 4.The power dissipation is limited by 150°C junction temperature
- 5.The data is theoretically the same as I_D and I_{DM} , in real applications , should be limited by total power dissipation.



P-Ch 100V Fast Switching MOSFETs

Typical Characteristics

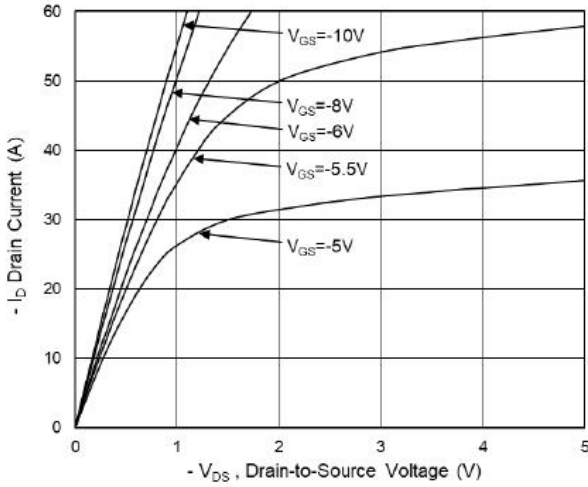

Fig.1 Typical Output Characteristics

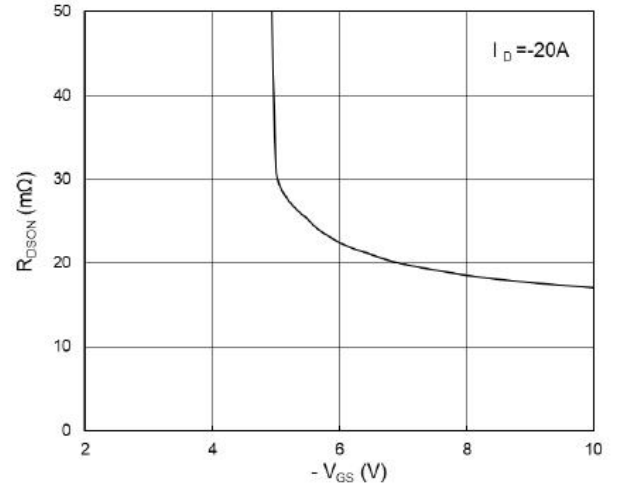

Fig.2 On-Resistance vs. G-S Voltage

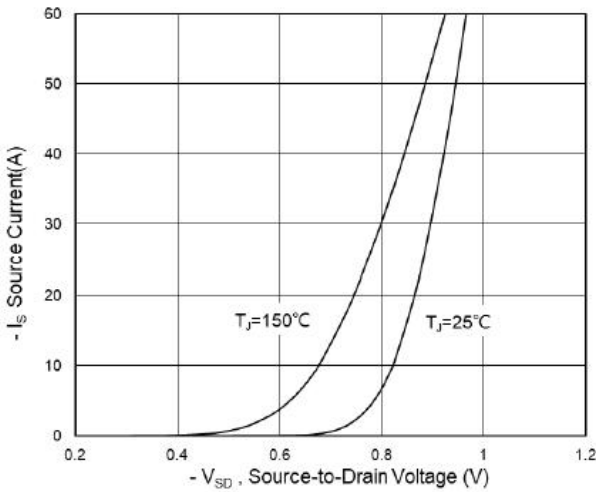

Fig.3 Typical S-D Diode Forward Voltage

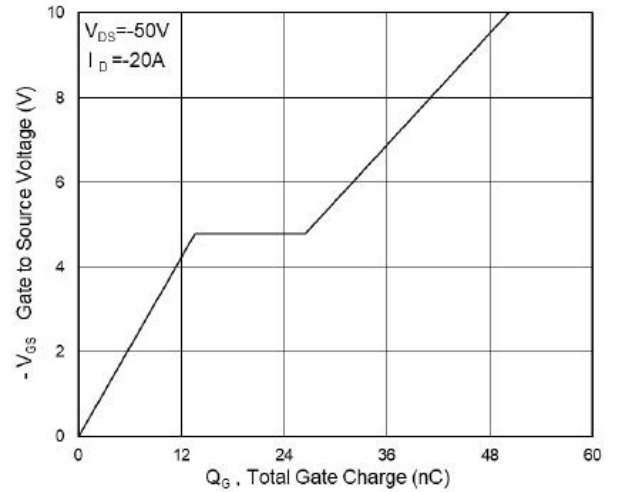

Fig.4 Gate-Charge Characteristics

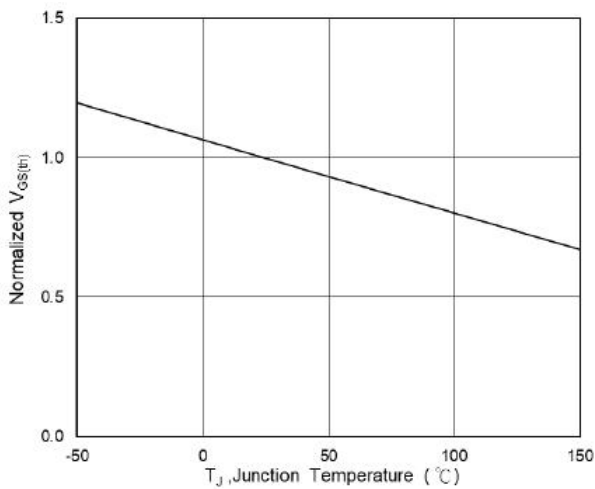

Fig.5 Normalized $V_{GS(th)}$ vs. T_J

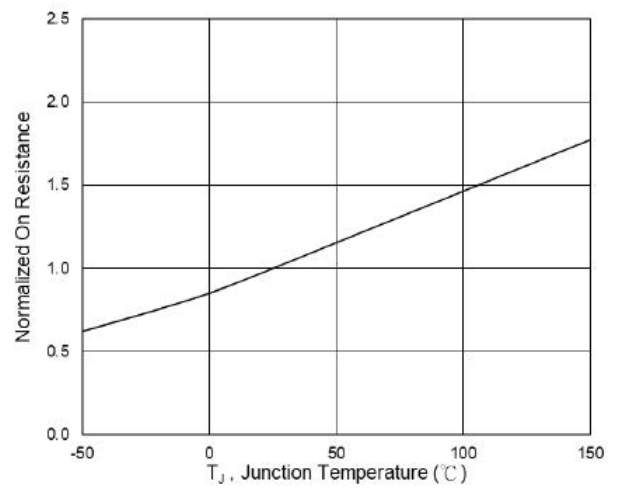

Fig.6 Normalized $R_{DS(on)}$ vs. T_J



P-Ch 100V Fast Switching MOSFETs

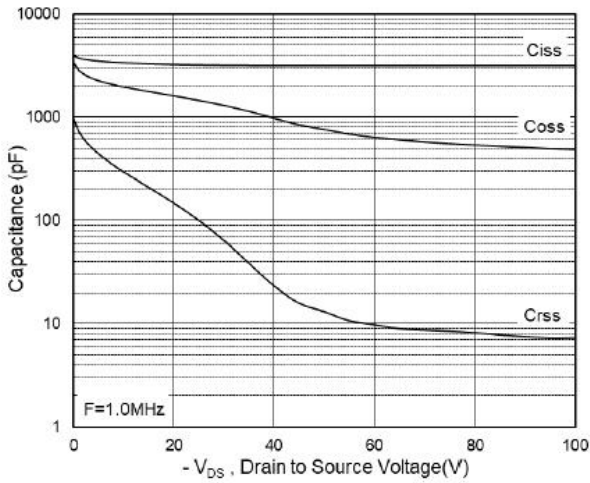

Fig.7 Capacitance

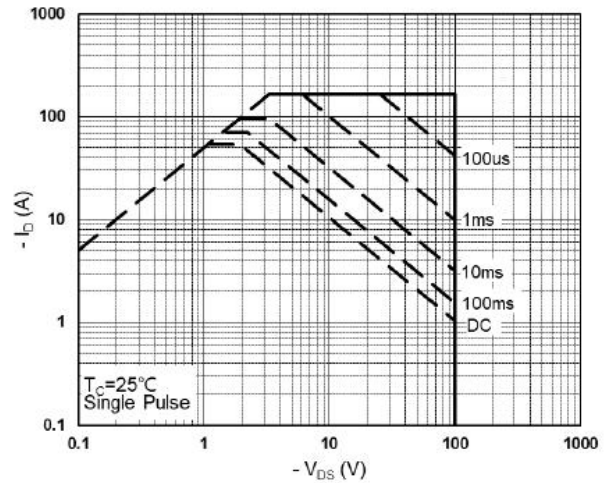

Fig.8 Safe Operating Area

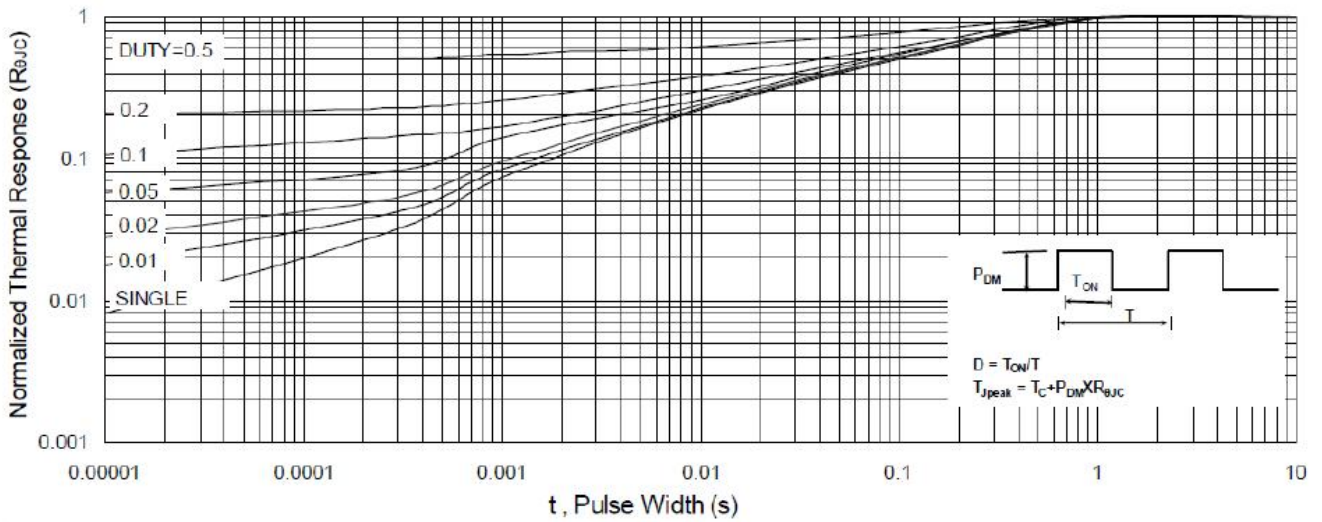

Fig.9 Normalized Maximum Transient Thermal Impedance

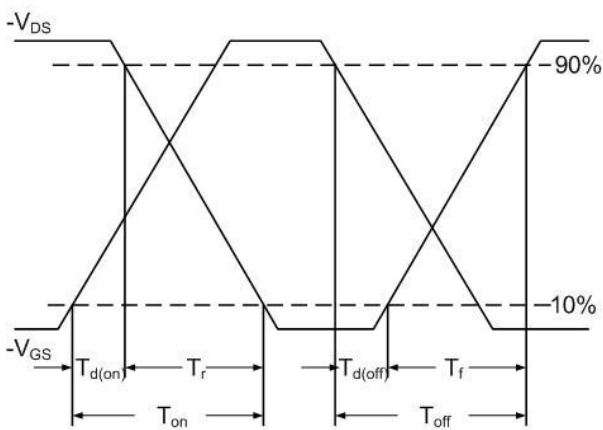

Fig.10 Switching Time Waveform

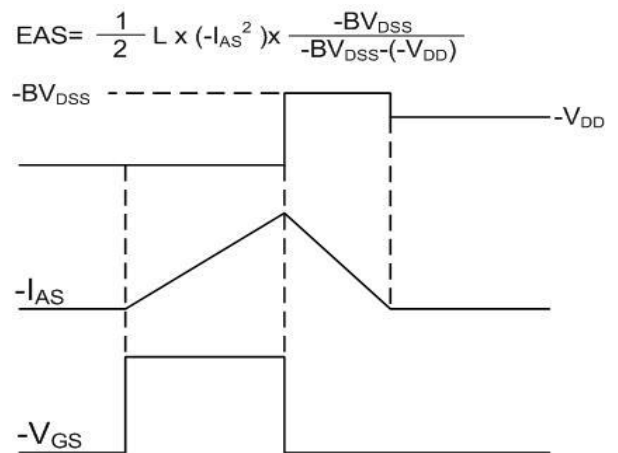
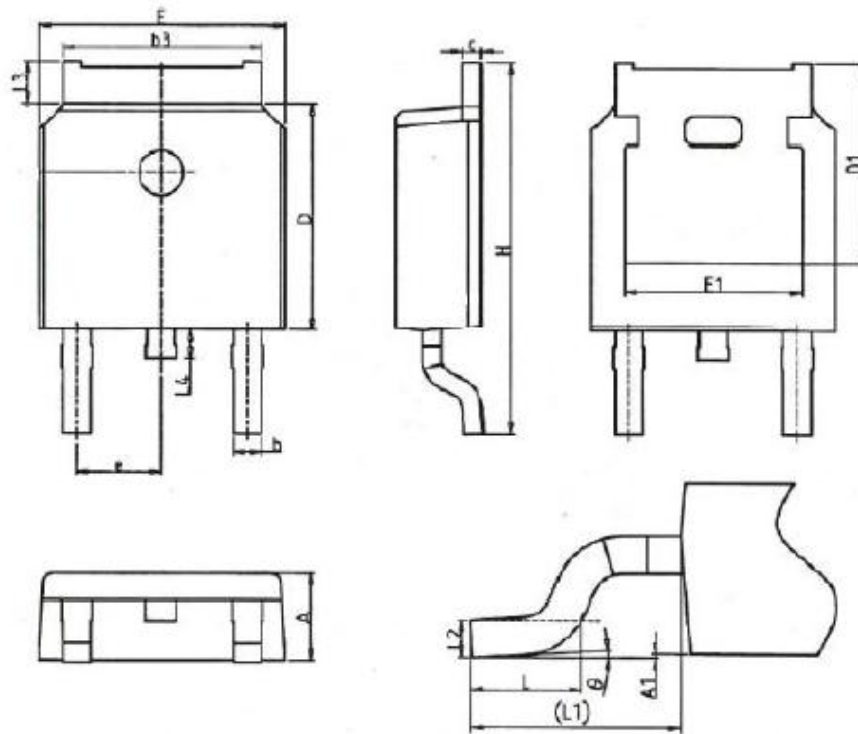

Fig.11 Unclamped Inductive Waveform



TO252-2L Package Outline



SYMBOLS	MILLIMETERS		INCHES	
	MIN	MAX	MIN	MAX
A	2.18	2.40	0.086	0.095
A1	-	0.2	-	0.008
b	0.68	0.9	0.026	0.036
b3	4.95	5.46	0.194	0.215
c	0.43	0.89	0.017	0.035
D	5.97	6.22	0.235	0.245
D1	5.300REF		0.209REF	
E	6.35	6.73	0.250	0.265
E1	4.32	--	0.170	-
e	2.286BSC		0.09BSC	
H	9.4	10.5	0.370	0.413
L	1.38	1.78	0.054	0.070
L1	2.90REF		0.114REF	
L2	0.51BSC		0.020BSC	
L3	0.88	1.28	0.034	0.050
L4	0.5	1	0.019	0.039
θ	0°	8°	0°	8°