

Precision, 16-bit 8/4-Channel 250 kSPS SAR ADC

Features

- 16-bit resolution with no missing codes
- Throughput: 250 kSPS
- INL: ± 1.25 LSB
- DNL: ± 0.45 LSB
- Dynamic Range: 93 dB
- SNR: 92.5 dB
- THD: -105 dB
- Single-ended or Pseudo Differential Range: $0\text{ V} \sim V_{REF}$
- Pseudo Differential Bipolar Range: $\pm V_{REF}/2$
- No Pipeline Delay
- Single Supply: 2.3 V \sim 5 V
- Logic Interface: 1.8 V/2.5 V/3 V/5 V
- Package: QFN-20
- Operating Temperature Range: -40 °C to +85 °C

Applications

- Relay Protection
- Precision Data Acquisition
- Automated Testing
- Battery Test
- Optical Communication

Block Diagram

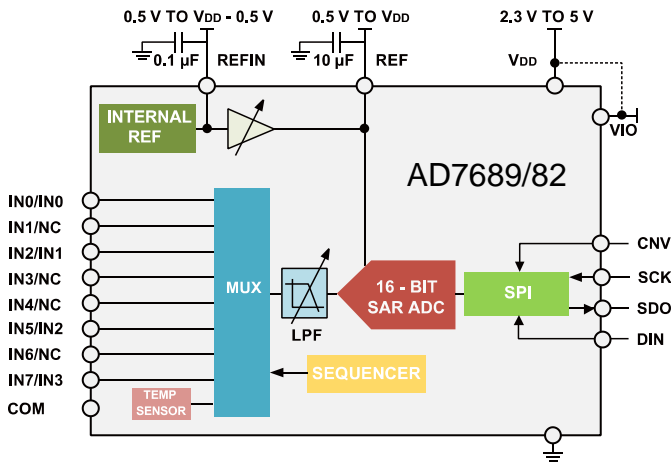

Figure 1. Block Diagram

Typical Characteristics

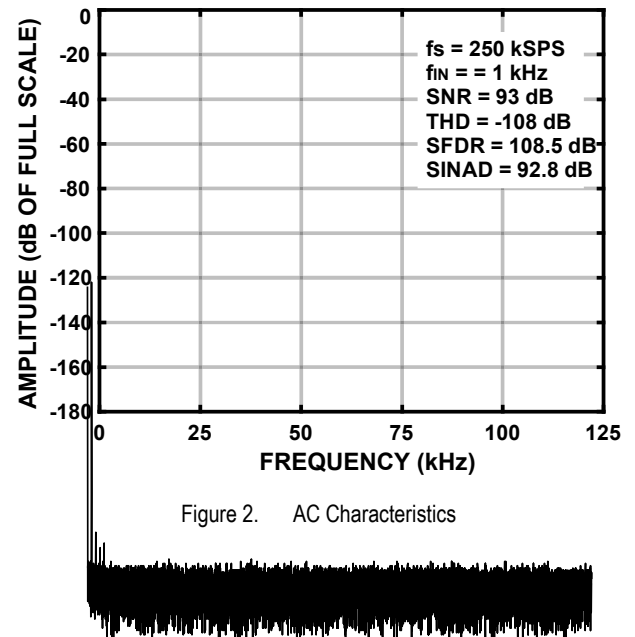

Figure 2. AC Characteristics

Pin Configurations and Function Descriptions

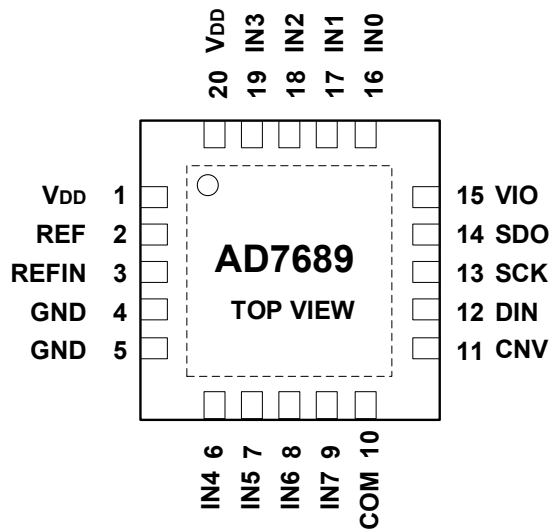

Figure 3. AD7689 -16 Pin Configuration

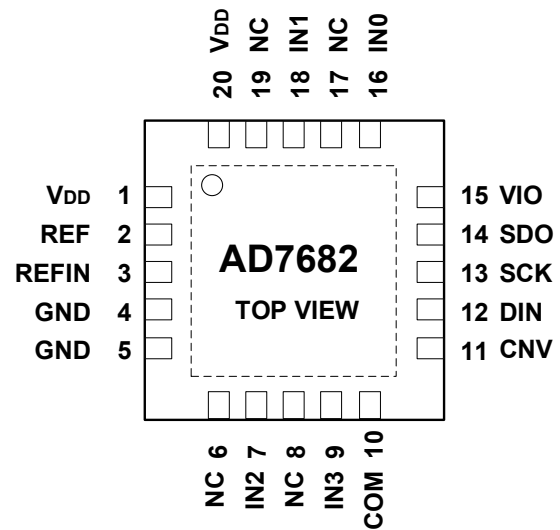

Figure 4. AD7682 -16 Pin Configuration

Note: The exposed pad has no internal connection. Connect the pad to GND.

Mnemonic		Pin No.	Pin Type	Description
V _{DD}	V _{DD}	1, 20	Power Supply	Power Supply. Nominally 2.3 V to 5.5 V when using an external reference and decoupled with 10 μ F and 100 nF capacitors. For internal reference 2.5 V, the minimum V _{DD} should be 3.0 V. For internal reference 4.096 V, the minimum V _{DD} should be 4.5 V.
REF	REF	2	Analog Input or Output	External Reference Input or Internal Reference Buffer Output. When the internal reference is enabled, it outputs a selectable reference 2.5 V or 4.096 V. When the internal reference is disabled and the buffer is enabled, REF produces a buffered reference voltage of the REFIN pin (4.096 V maximum). This pin needs decoupling with an external 10 μ F capacitor close to REF pin. See the Reference Decoupling section.
REFIN	REFIN	3	Analog Input or Output	Internal Reference Output or External Reference Buffer Input. When using the internal reference, the internal un-buffered bandgap reference voltage is present. It needs decoupling with a 0.1 μ F capacitor. When using the internal reference buffer, apply an external reference between 0.5 V and 4.096 V which is buffered to the REF pin.
GND	GND	4, 5	Ground	Power Supply Ground.
IN4	NC	6	Analog Input/NC	AD7689 -16: Analog Input Channel 4. AD7682 -16: No connection. Recommend connected to GND.
IN5	IN2	7	Analog Input	AD7689 -16: Analog Input Channel 5. AD7682 -16: Analog Input Channel 2.
IN6	NC	8	Analog Input/NC	AD7689 -16: Analog Input Channel 6. AD7682 -16: No connection. Recommend connected to GND.

Mnemonic		Pin No.	Pin Type	Description
IN7	IN3	9	Analog Input	AD7689 -16: Analog Input Channel 7. AD7682 -16: Analog Input Channel 3.
COM	COM	10	Analog Input	Common Channel Input. All input channels, can be referenced to a common-mode point of 0 V or $V_{REF}/2$.
CNV	CNV	11	Digital Input	Convert Input. On the rising edge, CNV initiates the conversion. During conversion, if CNV is high, the busy indicator is enabled.
DIN	DIN	12	Digital Input	Serial Data Input. This data input is used for writing to the 14-bit configuration register.
SCK	SCK	13	Digital Input	Serial Clock Input. This clock input is used to clock out the data on SDO and clock in data on DIN in an MSB first fashion.
SDO	SDO	14	Digital Output	Serial Data Output. The conversion codes are output on this pin by SCK. In unipolar modes, conversion codes are straight binary; in bipolar modes, conversion codes are twos complement.
VIO	VIO	15	Digital Power Supply	Digital Interface Power Supply. Nominally at the same supply as the host interface.
IN0	IN0	16	Analog Input	AD7689 -16: Analog Input Channel 0. AD7682 -16: Analog Input Channel 0.
IN1	NC	17	Analog Input	AD7689 -16: Analog Input Channel 1. AD7682 -16: No connection. Recommend connected to GND.
IN2	IN1	18	Analog Input	AD7689 -16: Analog Input Channel 2. AD7682 -16: Analog Input Channel 1.
IN3	NC	19	Analog Input	AD7689 -16: Analog Input Channel 3. AD7682 -16: No connection. Recommend connected to GND.
EPAD	EPAD	Exposed Pad	NC	The exposed pad is not connected internally. Recommended connecting the pad to the ground plane.

Absolute Maximum Ratings ¹

Parameter	Rating
V_{DD} , REF, VIO to GND	-0.3 V ~ 6 V
REF, VIO to V_{DD}	-6 V ~ $V_{DD} + 0.3$ V
Analog Input Range (INx to GND)	-0.3 V ~ $V_{DD} + 0.3$ V
Digital Input to GND	-0.3 V ~ VIO + 0.3 V
Digital Output to GND	-0.3 V ~ VIO + 0.3 V
Storage Temperature Range	-65 °C to 150 °C
Junction Temperature Range	150 °C
Lead Temperature (Soldering, 10 seconds)	300 °C
Maximum Reflow Temperature	260 °C
Electrostatic Discharge (ESD)	
Human Body Model (HBM)	1.5 kV
Charged Device Model (CDM)	1 kV

Thermal Resistance ⁶

Package	θ_{JA}	θ_{JC}	Unit
QFN-20	51	27	°C/W

Specifications

The ● denotes the full temperature range for specified performance. Unless otherwise noted, $V_{DD} = 4.5\text{ V} \sim 5.5\text{ V}$, $V_{REF} = V_{DD}$, $T_A = 25\text{ }^\circ\text{C}$.

Parameter	Symbol	Conditions	Min	Typ	Max	Unit
Resolution			16			

Input Characteristics

Voltage Range		Unipolar	●	0		V_{REF}	V
		Bipolar	●	$-V_{REF}/2$		$+V_{REF}/2$	
Absolute input voltage		INx+ to GND	●	-0.1		$V_{REF} + 0.1$	V
		INx- or COM, Unipolar	●	-0.1		+0.1	V
		INx- or COM, Bipolar	●	$V_{REF}/2 - 0.1$		$V_{REF}/2 + 0.1$	V
Common Mode Rejection Ratio	CMRR	$f_{IN} = 230\text{ kHz}$			67		dB
Leakage Current		Acquisition Phase			1		nA
Input Impedance ¹							

Throughput

Full Bandwidth		$V_{DD} = 4.5\text{ V to }5.5\text{ V}$	●	0		250	kSPS
		$V_{DD} = 2.3\text{ V to }4.5\text{ V}$	●	0		200	
1/4 Bandwidth		$V_{DD} = 4.5\text{ V to }5.5\text{ V}$	●	0		62.5	
		$V_{DD} = 2.3\text{ V to }4.5\text{ V}$	●	0		50	
Transient Response		Full - scale step	●			2.2	μs

DC Accuracy

No Missing Codes			●	16			bits
Integral Nonlinear Error	INL		●	-2	± 1.25	+2	LSB ²
Differential Nonlinear Error	DNL		●	-0.9	± 0.45	+0.9	LSB
Transition Noise		$REF = V_{DD} = 5\text{ V}$			0.5		LSB
Gain Error	GE	Single - ended	●	-10	± 2	+10	LSB
Gain Error Matching					± 1		LSB
Gain Error Temperature Drift					± 0.5		ppm/ $^\circ\text{C}$
Zero Error	ZE	Single - ended	●	-8	± 2	+8	LSB
Zero Error Matching					± 1		LSB
Zero Error Temperature Drift					± 0.3		ppm/ $^\circ\text{C}$
Power Supply Sensitivity		$V_{DD} = 5\text{ V} \pm 5\%$			± 0.5		LSB

¹ See the Analog Inputs section.

² LSB means least significant bit. 1 LSB = 76.3 μV for 5 V input range.

Parameter	Symbol	Conditions	Min	Typ	Max	Unit
AC Accuracy						
Dynamic Range	DR	$V_{REF} = 5\text{ V}$	• 92	93		dB ³
SNR	SNR	$f_{IN} = 1\text{ kHz}, V_{REF} = 5\text{ V}$	• 91	92.5		dB
		$f_{IN} = 1\text{ kHz}, V_{REF} = 4.096\text{ V}, \text{ internal ref}$	• 89	91		
		$f_{IN} = 1\text{ kHz}, V_{REF} = 2.5\text{ V}, \text{ internal ref}$	• 85.3	87.3		
Signal-to (Noise + Distortion)	SINAD	$f_{IN} = 1\text{ kHz}, V_{REF} = 5\text{ V}$	• 90.9	92.4		dB
		$f_{IN} = 1\text{ kHz}, V_{REF} = 4.096\text{ V}, \text{ internal ref}$	• 88.8	90.8		
		$f_{IN} = 1\text{ kHz}, V_{REF} = 2.5\text{ V}, \text{ internal ref}$	• 85.2	87.2		
Spurious-Free Dynamic	SFDR	$f_{IN} = 1\text{ kHz}, V_{REF} = 5\text{ V}$		106		dB
Total Harmonic Distortion	THD	$f_{IN} = 1\text{ kHz}, V_{REF} = 5\text{ V}$		-105		dB
Channel Crosstalk		$f_{IN} = 1\text{ kHz}, V_{REF} = 5\text{ V}$		-120		dB
External Reference Input						
Voltage Range		REF Input	• 0.5		$V_{DD} + 0.3$	V
		REFIN Input (Buffer Enabled)	• 0.5		$V_{DD} - 0.5$	
Load Current		Sinewave Input		60		μA
Internal Reference Output						
REF Output Voltage		4.096 V, @ 25 °C	• 4.092	4.096	4.100	V
		2.5 V, @ 25 °C	• 2.495	2.5	2.505	
REFIN Output Voltage		REF = 4.096 V, @ 25 °C		2.42		V
		REF = 2.5 V, @ 25 °C		1.21		
REF Output Current				300		μA
Temperature Drift	T_c	-40 °C to +85 °C	•	6	10	ppm/°C
		0 °C to +85 °C		2		ppm/°C
Line Regulation		$V_{DD} = 5\text{ V} \pm 5\%$		20		ppm/V
Turn-On Settling Time		$C_{REFIN} = 0.1\ \mu\text{F}, C_{REF} = 10\ \mu\text{F}$		10		ms
Sampling Dynamics						
-3 dB Analog Input Bandwidth		$V_{DD} = 5\text{ V}, \text{ Full Bandwidth}$		6		MHz
		$V_{DD} = 5\text{ V}, 1/4 \text{ Bandwidth}$		1.5		
Aperture Delay		$V_{DD} = 5\text{ V}$		3		ns
Temperature Sensor						
Output Voltage		@ 25 °C		300		mV
Temperature Sensitivity				1		mV/°C

³ Unless otherwise noted, all specifications expressed in decibels (dB) are referenced to full-scale input FSR and are tested with an input signal 0.5 dB below full-scale.

Parameter	Symbol	Conditions	Min	Typ	Max	Unit	
Digital Input							
Logic Level	V_{IL}		• -0.3		$0.3 \times V_{IO}$	V	
	V_{IH}		• $0.7 \times V_{IO}$		$V_{IO} + 0.3$		
Input Current	I_{IL}		• -1		+1	μA	
	I_{IH}		• -1		+1		
Digital Output							
Data Format		Single-ended, or Pseudo Diff Unipolar			Serial 16 - bit, straight binary		
		Pseudo Diff Bipolar			Serial 16 - bit, twos complete		
Logic Low Voltage	V_{OL}	$I_{OUT} = +200 \mu A$	•		0.4	V	
Logic High Voltage	V_{OH}	$I_{OUT} = -200 \mu A$	•	$V_{IO} - 0.3$		V	
Power Supplies							
V_{DD}		Specified performance		4.5	5.5	V	
V_{DD}		Operating Range		2.3	5.5	V	
V_{IO}		Specified performance		1.8	$V_{DD} + 0.3$	V	
Power-down Current		V_{DD} and $V_{IO} = 5 V$, @ 25 °C			50	nA	
Power Consumption		$V_{DD} = 5 V$, 1 kSPS	•		34	38	μW
		$V_{DD} = 5 V$, 100 kSPS	•		3.4	3.8	mW
		$V_{DD} = 5 V$, 250 kSPS	•		8.5	9.5	mW
		$V_{DD} = 5 V$, 250 kSPS, internal ref	•		13	15	mW
Temperature Range							
Specified Performance		T_{MIN} to T_{MAX}		-40	+85	°C	

Timing Specifications

The ● denotes the full temperature range for specified performance. Unless otherwise specified, $V_{DD} = 4.5\text{ V} \sim 5.5\text{ V}$, $V_{REF} = V_{DD}$, $V_{IO} = 1.8\text{ V} \sim V_{DD}$, $T_A = -40\text{ }^\circ\text{C}$ to $+85\text{ }^\circ\text{C}$.

Parameter	Symbol		Min	Typ	Max	Unit
Conversion Time: CNV Rising Edge to Data Available	t_{CONV}	●			1.8	μs
Acquisition Time	t_{ACQ}	●	2.2			μs
Time Between Conversions	t_{CYC}	●	4.0			μs
Data Write/Read During Conversion	t_{DATA}	●			1.0	μs
CNV Pulse Width	t_{CNVH}	●	10			ns
SCK Period ($V_{IO} > 3.3\text{ V}$)	t_{SCK}	●	15			ns
VIO above 2.7 V		●	20			ns
VIO above 2.3 V		●	25			ns
VIO above 1.8 V		●	40			ns
SCK Low Time ($V_{IO} > 3.3\text{ V}$)	t_{SCKL}	●	7.5			ns
SCK High Time ($V_{IO} > 3.3\text{ V}$)	t_{SCKH}	●	7.5			ns
SCK Falling Edge to Data Remain Valid	t_{HSDO}	●	4			ns
SCK Falling Edge to Data Valid Delay	t_{DSDO}					
VIO above 2.7 V		●			17	ns
VIO above 2.3 V		●			18	ns
VIO above 1.8 V		●			21	ns
CNV Low to SDO MSB Valid	t_{EN}					
VIO above 2.7 V		●			22	ns
VIO above 2.3 V		●			25	ns
VIO above 1.8 V		●			28	ns
CNV High or Last SCK Falling Edge to SDO High Impedance	t_{DIS}				25	ns
CNV Low to SCK Rising Edge	t_{CLCLK}	●	10			ns
Last SCLK Falling Edge to CNV Rising Edge Delay	t_{QUIET}	●	140			ns
DIN Valid Setup Time from SCK Rising Edge	t_{SDIN}	●	5			ns
DIN Valid Hold Time from SCK Rising Edge	t_{HDIN}	●	5			ns

Timing Specifications Continued

The ● denotes the full temperature range for specified performance. Unless otherwise specified, $V_{DD} = 2.3\text{ V} \sim 4.5\text{ V}$, $V_{REF} = V_{DD}$, $V_{IO} = 1.8\text{ V} \sim V_{DD}$, $T_A = -40\text{ }^\circ\text{C}$ to $+85\text{ }^\circ\text{C}$.

Parameter	Symbol		Min	Typ	Max	Unit
Conversion Time: CNV Rising Edge to Data Available	t_{CONV}	●			3.1	μs
Acquisition Time	t_{ACQ}	●	1.9			μs
Time Between Conversions	t_{CYC}	●	5.0			μs
Data Write/Read During Conversion	t_{DATA}	●			1.0	μs
CNV Pulse Width	t_{CNVH}	●	10			ns
SCK Period ($V_{IO} > 3.3\text{ V}$)	t_{SCK}	●	15			ns
VIO above 2.7 V		●	20			ns
VIO above 2.3 V		●	25			ns
VIO above 1.8 V		●	40			ns
SCK Low Time ($V_{IO} > 3.3\text{ V}$)	t_{SCKL}	●	7.5			ns
SCK High Time ($V_{IO} > 3.3\text{ V}$)	t_{SCKH}	●	7.5			ns
SCK Falling Edge to Data Remain Valid	t_{HSDO}	●	4			ns
SCK Falling Edge to Data Valid Delay	t_{DSDO}					
VIO above 2.7 V		●			17	ns
VIO above 2.3 V		●			18	ns
VIO above 1.8 V		●			21	ns
CNV Low to SDO MSB Valid	t_{EN}					
VIO above 2.7 V		●			22	ns
VIO above 2.3 V		●			25	ns
VIO above 1.8 V		●			28	ns
CNV High or Last SCK Falling Edge to SDO High Impedance	t_{DIS}				25	ns
CNV Low to SCK Rising Edge	t_{CLCLK}	●	10			ns
Last SCLK Falling Edge to CNV Rising Edge Delay	t_{QUIET}	●	150			ns
DIN Valid Setup Time from SCK Rising Edge	t_{SDIN}	●	5			ns
DIN Valid Hold Time from SCK Rising Edge	t_{HDIN}	●	5			ns

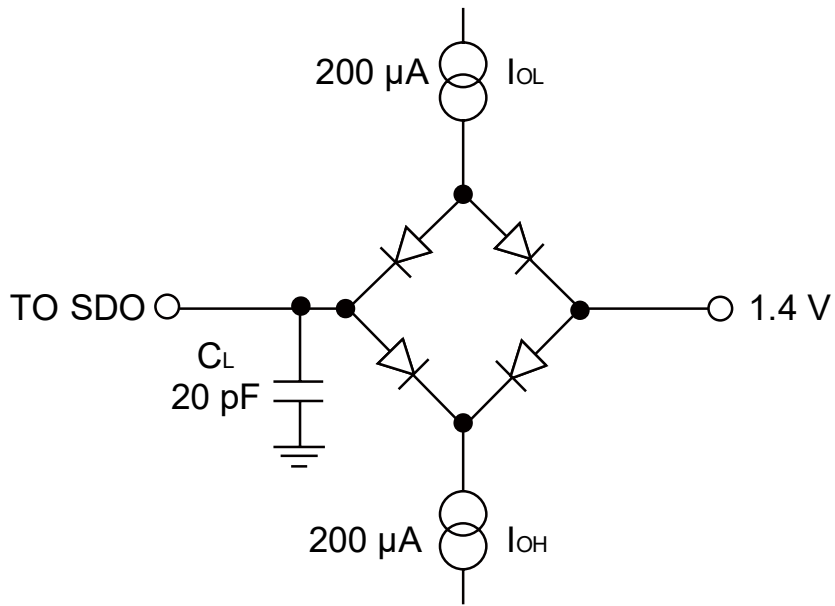

Figure 5. Load Circuit for Digital Interface Timing

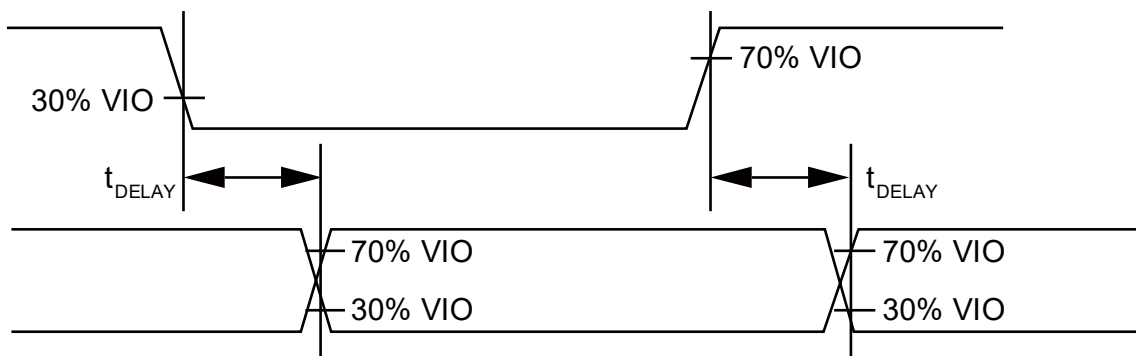

Figure 6. Voltage Levels for Timing

Typical Performance Characteristics

Unless otherwise noted, $V_{DD} = 5.0\text{ V}$, $V_{REF} = 5.0\text{ V}$, $V_{IO} = 3.3\text{ V}$, $T_A = 25\text{ }^\circ\text{C}$.

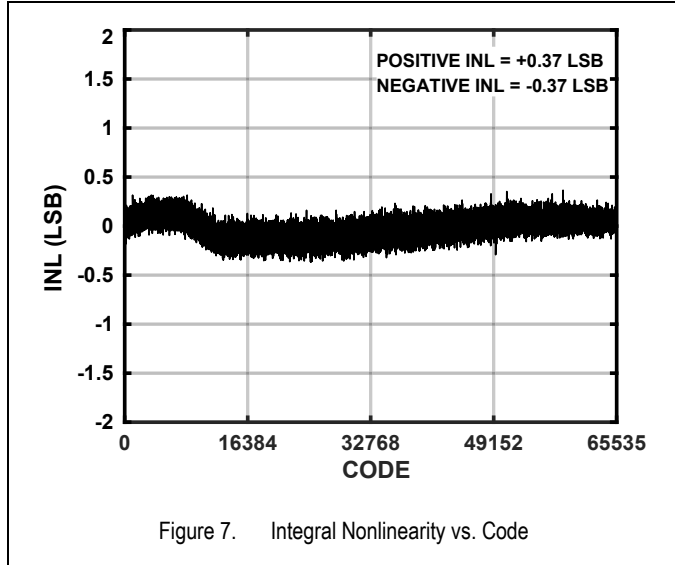

Figure 7. Integral Nonlinearity vs. Code

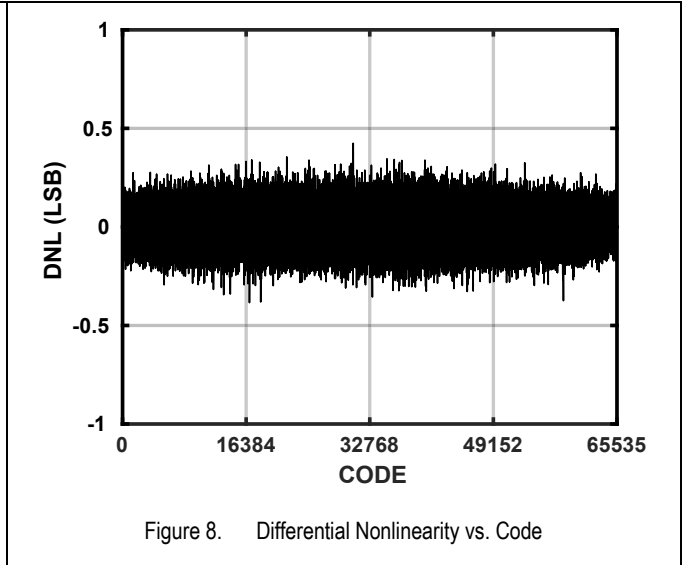

Figure 8. Differential Nonlinearity vs. Code

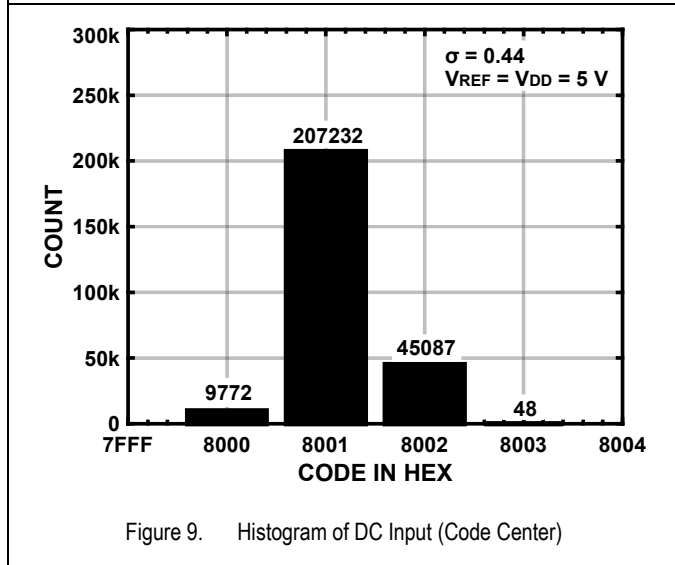

Figure 9. Histogram of DC Input (Code Center)

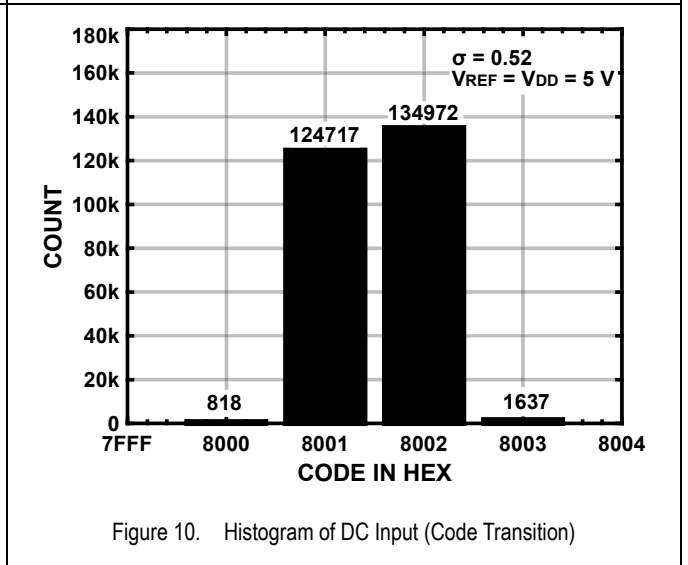

Figure 10. Histogram of DC Input (Code Transition)

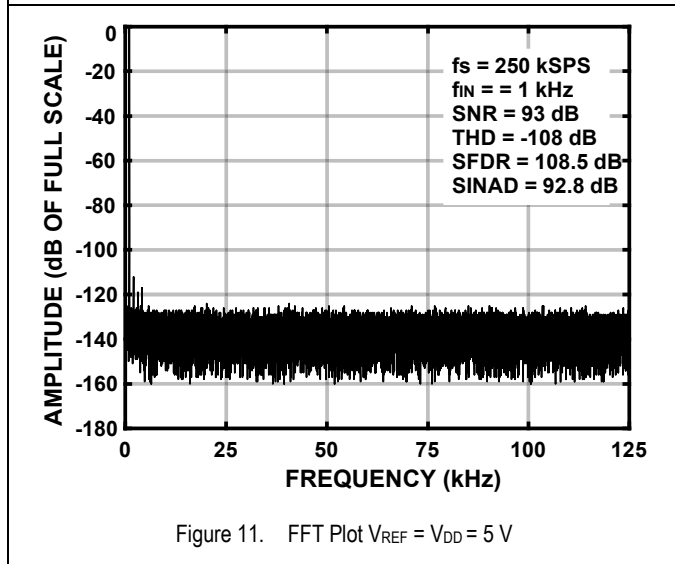

Figure 11. FFT Plot $V_{REF} = V_{DD} = 5\text{ V}$

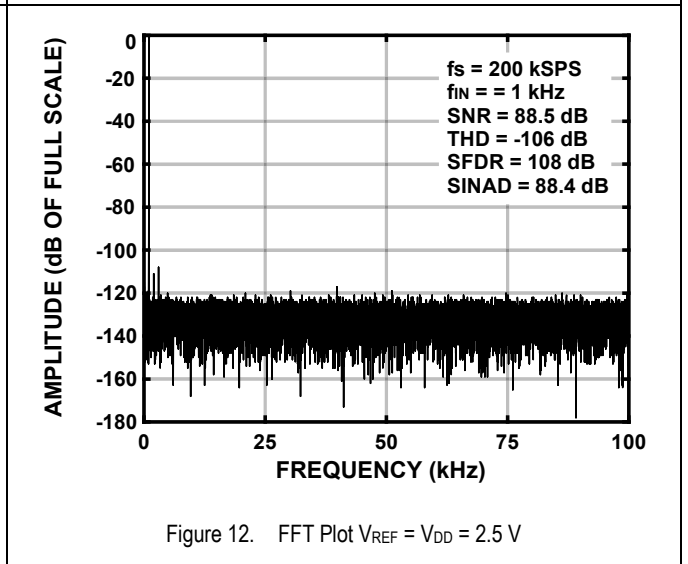
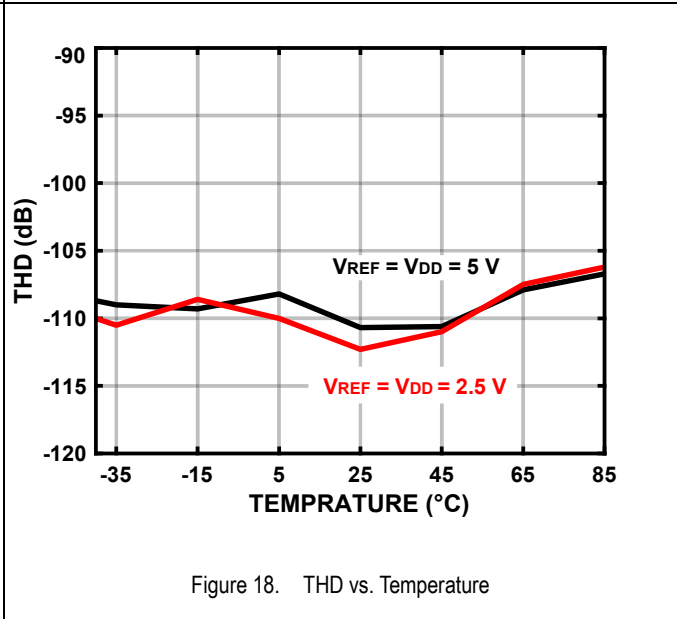
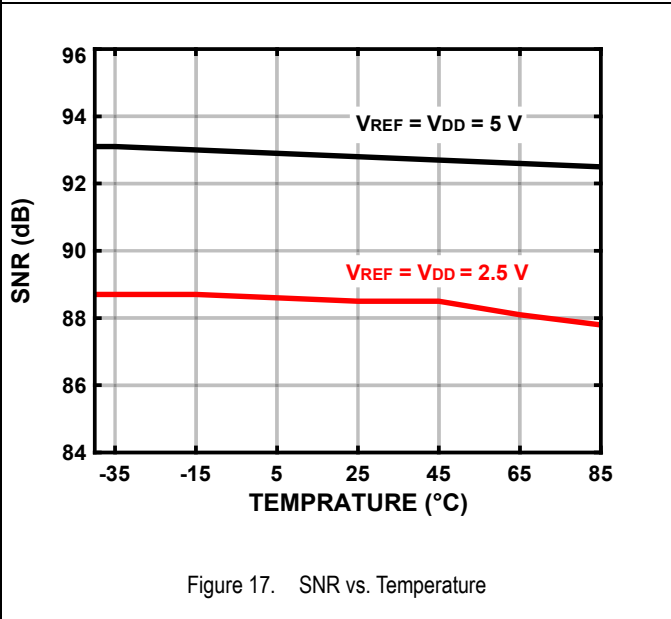
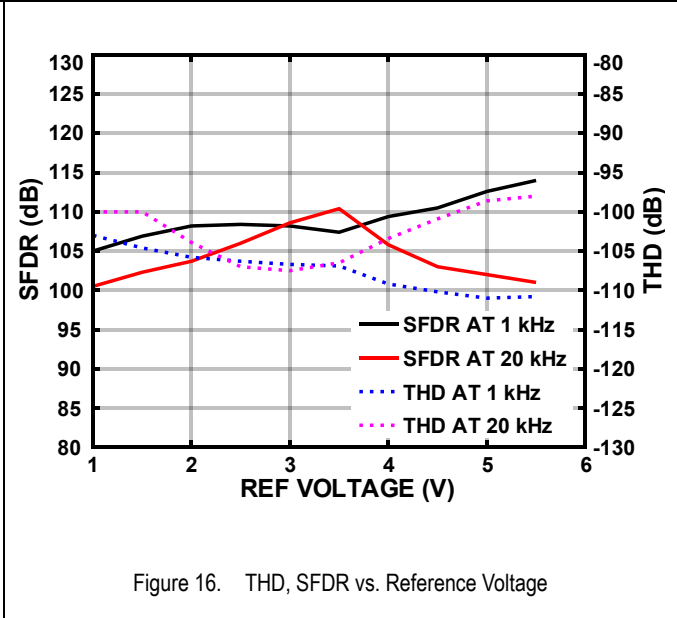
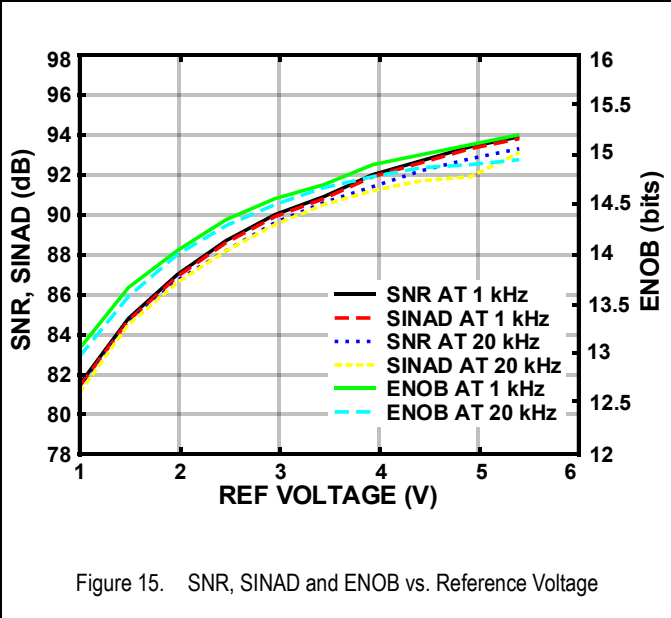
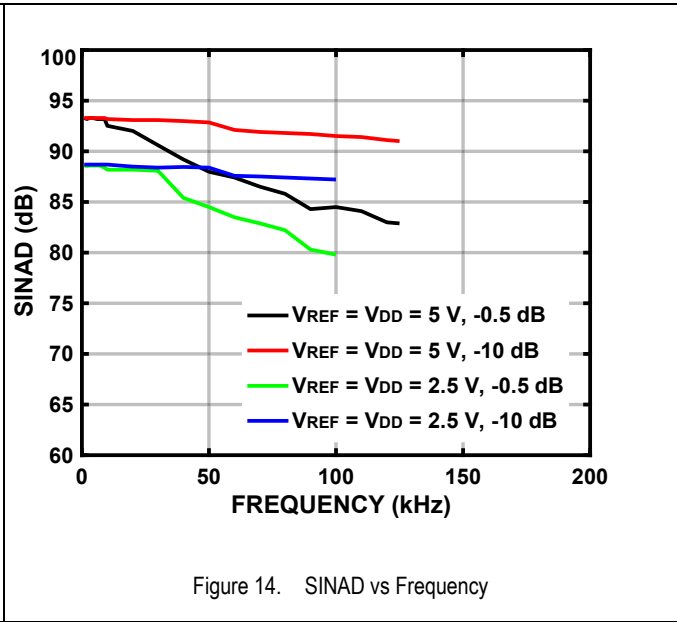
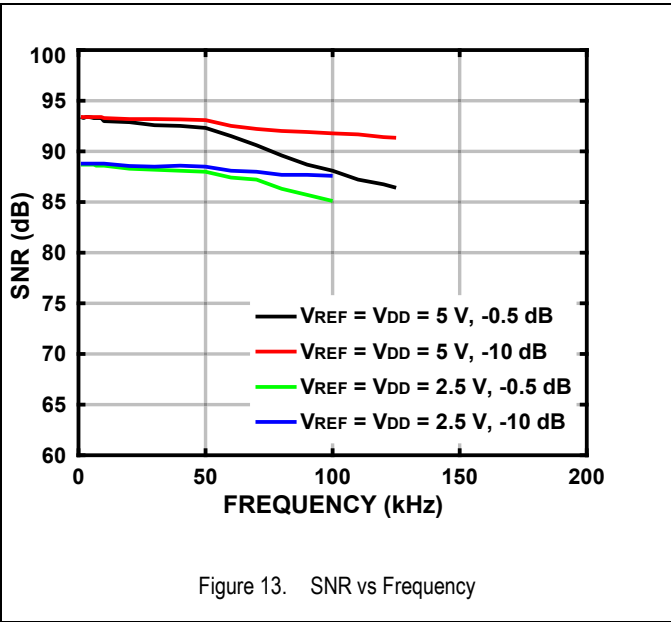
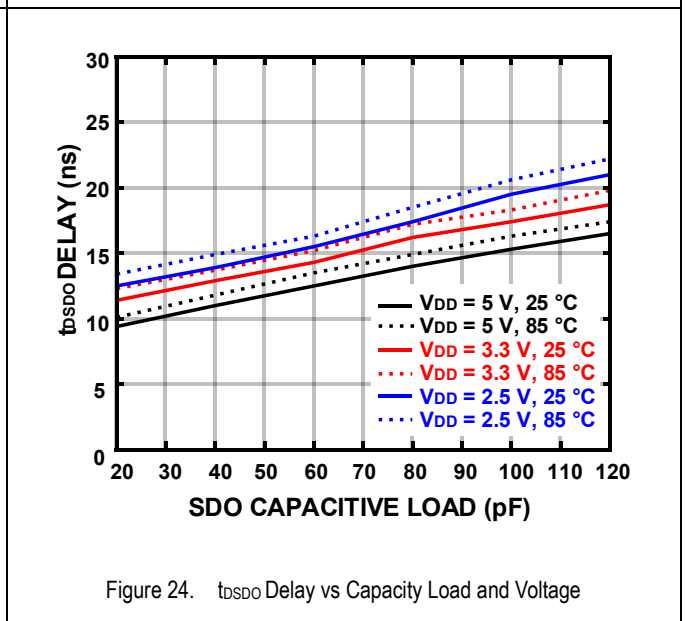
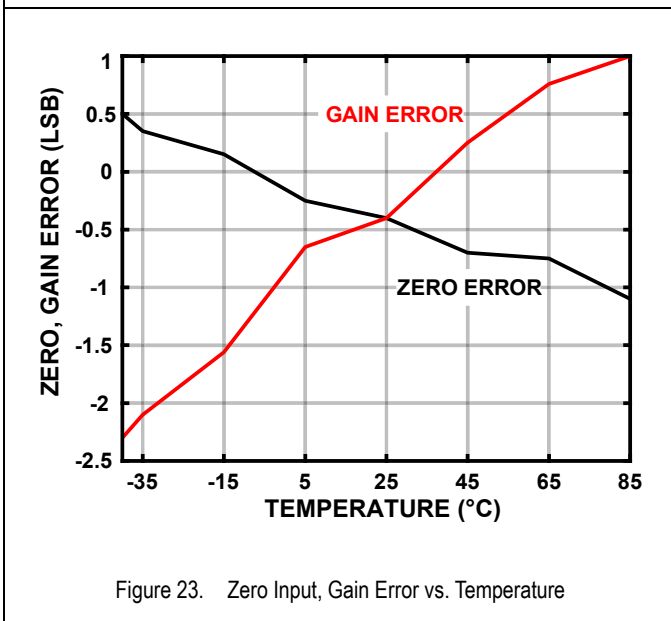
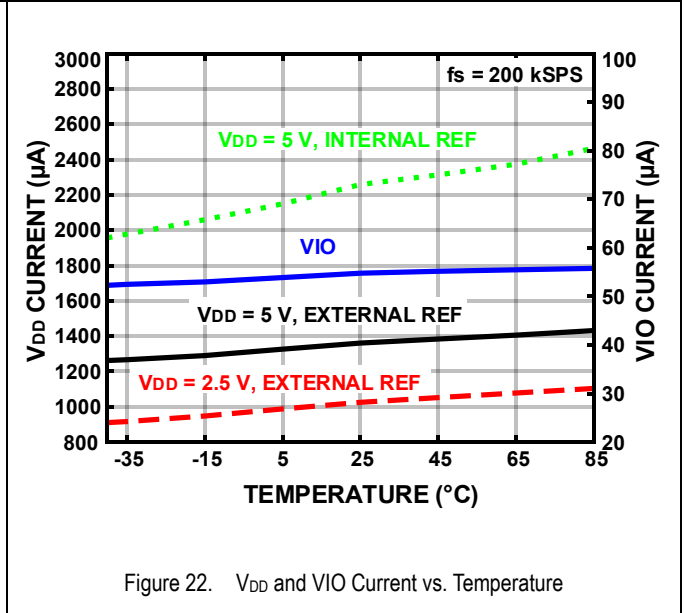
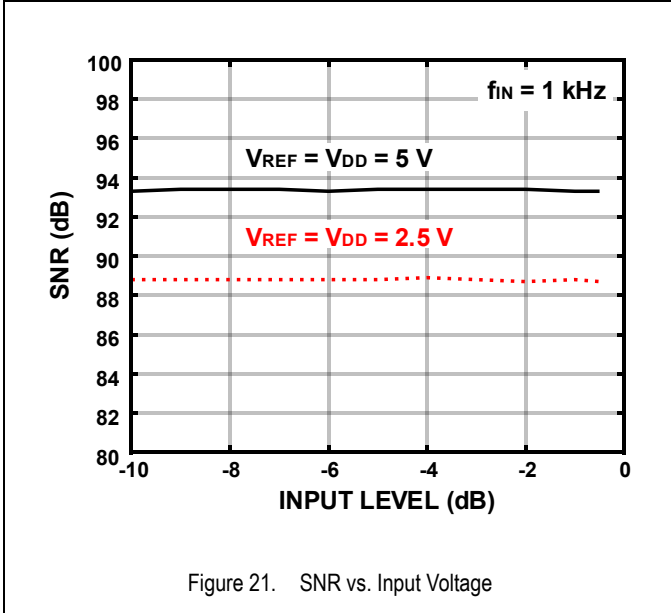
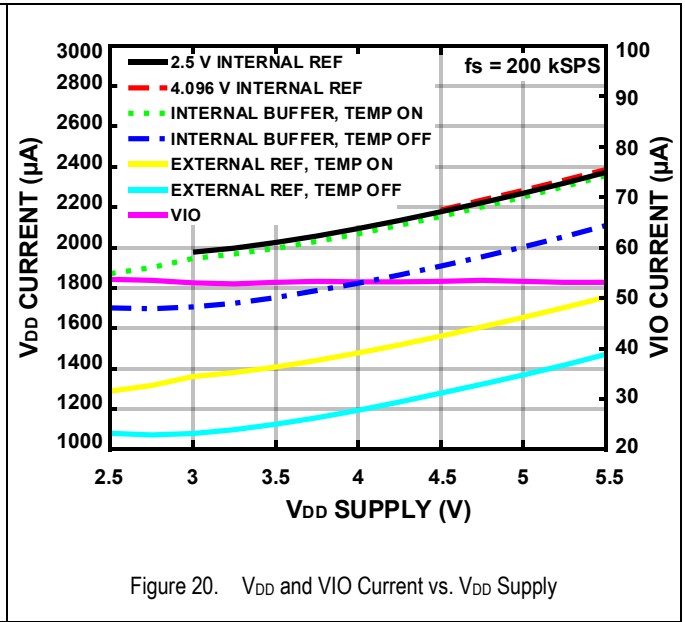
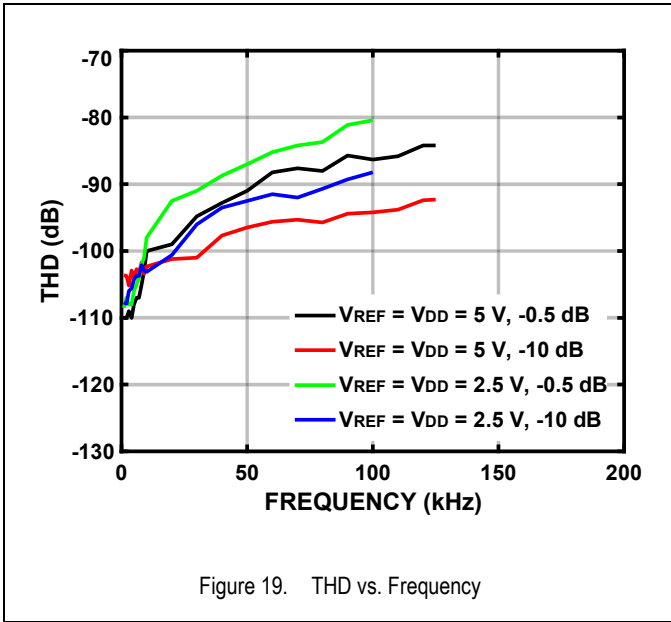

Figure 12. FFT Plot $V_{REF} = V_{DD} = 2.5\text{ V}$





Theory of Operation

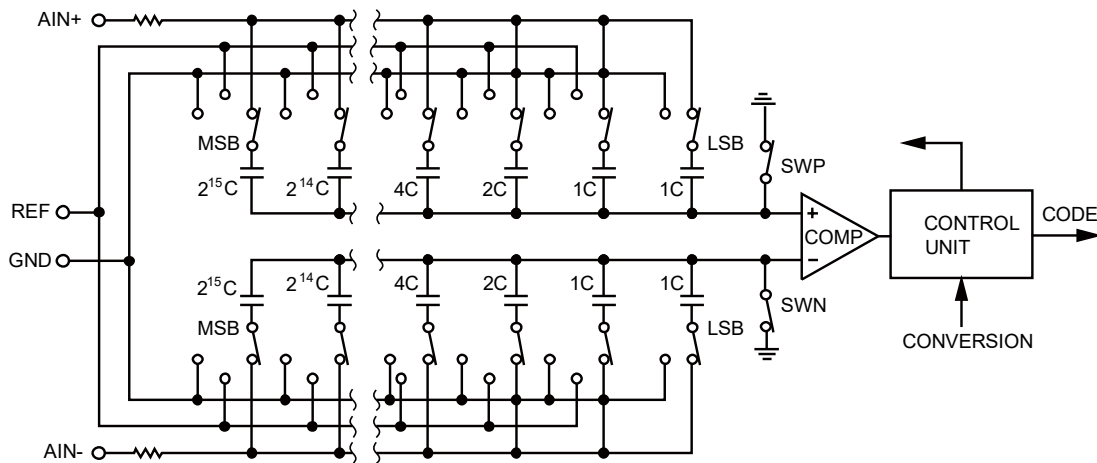

Figure 25. ADC Simplified Circuit Diagram

Circuit Structure

The AD7689/82-16 is an 8/4-channel, 16-bit, charge redistribution successive approximation register analog-to-digital converter. The AD7689/82-16 is capable of running up to 250 kSPS and powers down between conversions.

The AD7689/82-16 contains a 16-bit SAR ADC, an 8/4-channel, low crosstalk multiplexer to configure the inputs as single-ended, pseudo differential unipolar or bipolar; an internal low drift reference (selectable 2.5 V or 4.096 V) and reference driver; a temperature sensor; a selectable one-pole filter; and a digital sequencer which is useful for channels being continuously scanned in order.

Converter Operation

Figure 25 is a simplified circuit diagram of AD7689/82-16.

In the acquisition phase, the array node connected to the input of the comparator is short connect to GND via the SW+ and SW-. All individual switches are connected to analog inputs. When the acquisition phase is complete and a rising edge occurs on the CNV input, the conversion phase is initiated. When the conversion phase begins, the SW+ and SW- disconnect first. The two capacitor arrays are then disconnected from the input and connected to the GND input. By switching the elements of the capacitor array between GND and REF, the comparator input will vary in binary weighted voltage steps ($V_{REF}/2^1$, $V_{REF}/2^2$, ..., $V_{REF}/2^{15}$). The control logic toggles these switches in sequence starting with the MSB, and the comparator is brought back into balance each time. After this phase is complete, the device returns to the acquisition phase, and the control logic generates the ADC output code.

Transfer Function

When configured as singled-ended or pseudo differential unipolar (single-ended INx to GND, COM to GND, temperature sensor, IN- to GND), the code is straight binary. The ideal transfer characteristic is shown below:

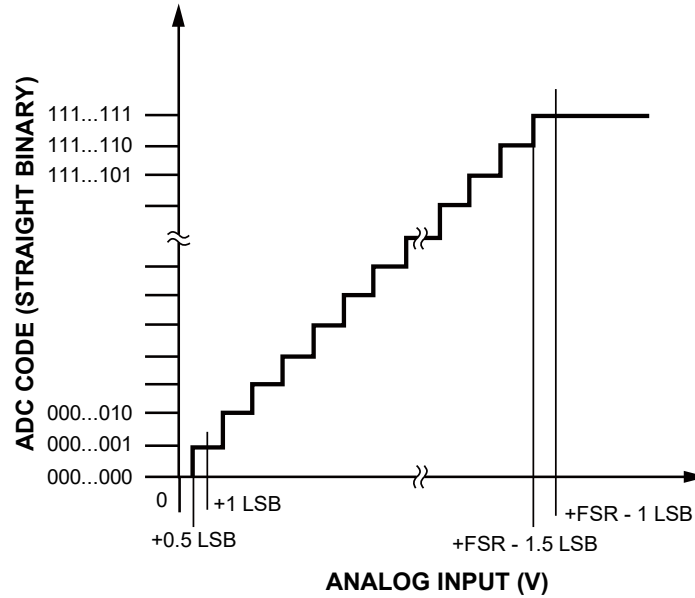

Figure 26. ADC Ideal Transfer Function of Singled-ended or Pseudo Differential Unipolar

Singled-ended or Pseudo Differential Unipolar Output Codes and Ideal Input Voltages

Description	Analog Input $V_{REF} = 5\text{ V}$	Digital Output (Hex)
FSR - 1 LSB	4.999924 V	0xFFFF ¹
Midscale + 1 LSB	2.500076 V	0x8001
Midscale	2.5 V	0x8000
Midscale - 1 LSB	2.499924 V	0x7FFF
-FSR + 1 LSB	76.3 μV	0x0001
-FSR	0 V	0x0000 ²

When configured as pseudo differential bipolar ($\text{COM} = V_{REF} / 2$ or $\text{INx-} = V_{REF} / 2$), the code is twos complement.

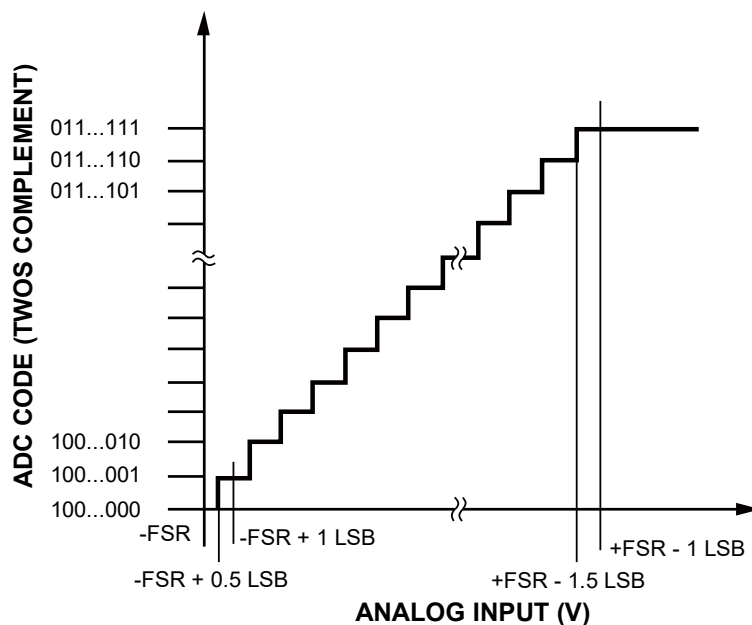

Figure 27. ADC Ideal Transfer Function of Pseudo Differential Bipolar

Pseudo Differential Bipolar Output Codes and Ideal Input Voltages

Description	Analog Input $V_{REF} = 5\text{ V}$	Digital Output (Hex)
FSR - 1 LSB	+2.499924 V	0x7FFF ¹
Midscale + 1 LSB	+76.3 μV	0x0001
Midscale	0 V	0x0000
Midscale - 1 LSB	-76.3 μV	0xFFFF
-FSR + 1 LSB	-2.499924 V	0x8001
-FSR	-2.5 V	0x8000 ²

¹ This is also the code for an overranged analog input ($(IN_+) - (IN_-)$, above $V_{REF} - \text{GND}$).

² This is also the code for an underranged analog input ($(IN_+) - (IN_-)$, below GND).

Typical Connection

Figure 28 is a suggested connection for the AD7689/82-16 when multiple power supplies are used.

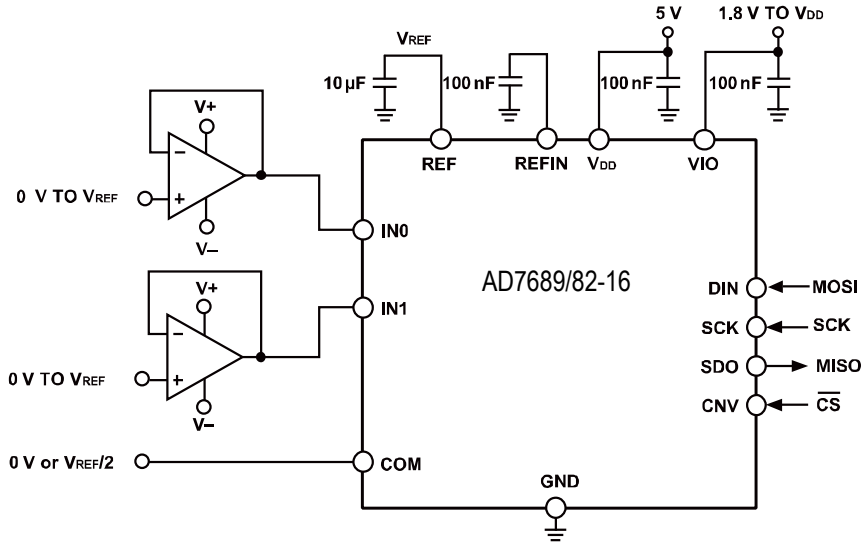

Figure 28. Application Circuits Using Multiple Power Supplies

Figure 29 shows the equivalent circuit of the AD7689/82-16 input structure.

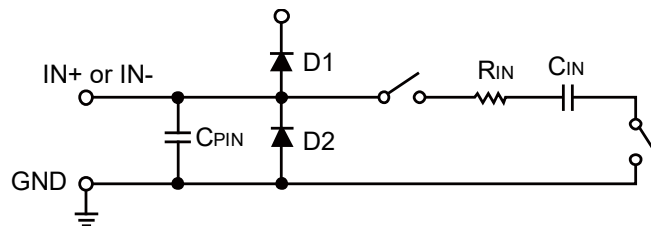

Figure 29. Two Diodes D1 and D2 Provide ESD Protection for the Analog Inputs

The voltage of the analog input signal cannot be higher than the supply voltage (V_{DD}) by more than 0.3 V. If the voltage of the analog input signal exceeds $V_{DD} + 0.3$ V, the diode will be forward biased and start conducting current. These two diodes can handle forward bias currents up to 50 mA. If the supply voltage of the input driver is higher than V_{DD} the voltage of the analog input signal may be more than 0.3 V higher than the supply voltage. The two diodes D1 and D2 provide ESD protection for analog input IN+ and IN-.

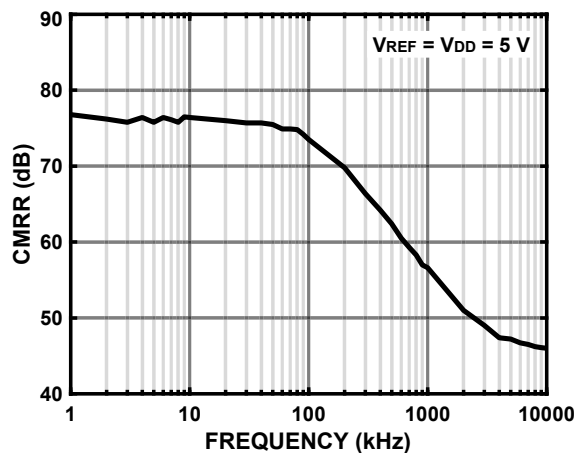

Figure 30. Analog Input CMRR vs. Frequency

In the acquisition phase, the impedance of the analog inputs can be modeled as a parallel combination of the capacitor, C_{PIN} , and the network formed by the series connection of R_{IN} and C_{IN} . C_{PIN} is primarily the pin capacitance. R_{IN} is typically $700\ \Omega$ and is a lumped component composed of serial resistors and the on resistance of the switches. C_{IN} is typically $30\ \text{pF}$ and is mainly the ADC sampling capacitor.

Fully Differential to Single-ended Driver

For applications using fully differential analog signals (bipolar or unipolar), an op amp driver can provide pseudo differential unipolar input to the AD7689/82-16, see Figure 31 for the schematic diagram.

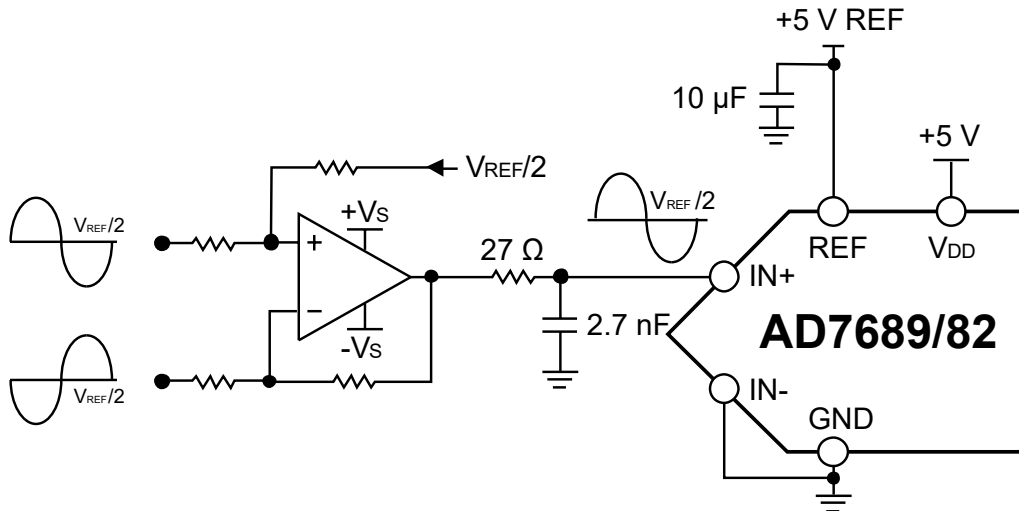

Figure 31. Fully Differential to Single-ended Conversion with an Op Amp

Singled-ended bipolar signal can be converted to pseudo differential unipolar signal with two amplifiers for AD7689/82-16.

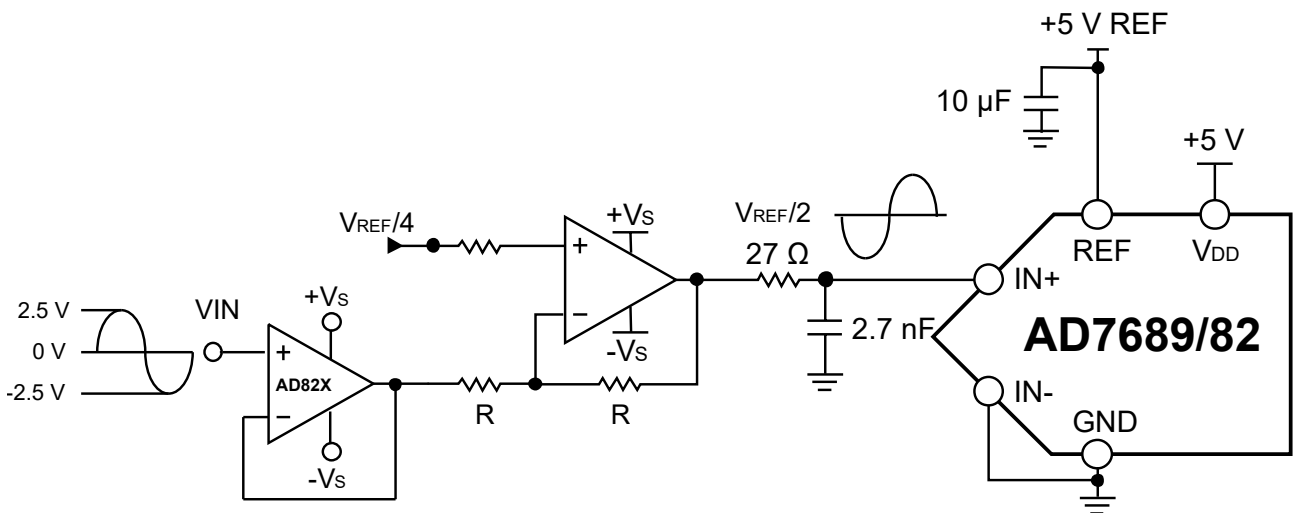

Figure 32. Single-ended Bipolar to Pseudo Differential Unipolar

Input Configurations

Figure 33 shows configuring the analog inputs with the configuration register CFG [12 : 10].

The analog inputs can be configured as:

- Figure 33A, all single-ended INx inputs referenced to ground; CFG [12 : 10] = 111. In this configuration, all inputs (IN [7:0]) have a range of GND to V_{REF} .
- Figure 33B, pseudo differential bipolar with a common reference point; $COM = V_{REF} / 2$; CFG [12 : 10] = 010. Pseudo differential unipolar with $COM = 0 V$; CFG [12 : 10] = 110. All inputs IN [7 : 0] referred to GND have a range of GND to V_{REF} .
- Figure 33C, pseudo differential bipolar pairs with the negative input channel referenced to $V_{REF}/2$; CFG [12 : 10] = 00X. Pseudo differential unipolar pairs with the negative input channel referenced to a ground sense; CFG [12:10] = 10X. In these configurations, the positive input channels have the range of GND to V_{REF} . The negative input channels are senses referred to $V_{REF}/2$ for bipolar pairs, or GND for unipolar pairs. If CFG [9 : 7] is even, then IN0, IN2, IN4, and IN6 are used as positive inputs. If CFG [9 : 7] is odd, then IN1, IN3, IN5, and IN7 are used as positive inputs. Note that for the sequencer, the positive channels are always IN0, IN2, IN4, and IN6.
- Figure 33D, inputs configured in any of the combinations above.

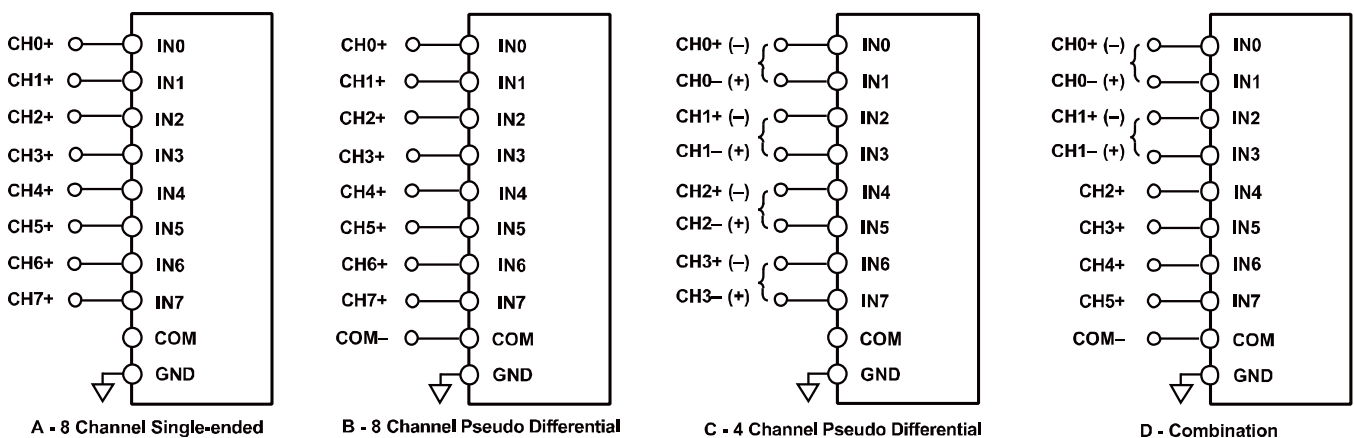

Figure 33. Multiplexed Analog Input Configurations

Internal Reference/Temperature

The AD7689/82-16 internal precision reference, can be set for either a 2.5 V or a 4.096 V on REF pin. When the internal reference is enabled, the band gap voltage is present on the REFIN pin. Because the current output of REFIN is limited, it can be used as a source if followed by a suitable buffer, such as the AD82XX. Note that the voltage of REFIN changes depending on the 2.5 V or 4.096 V internal reference.

Enabling the reference also enables the internal temperature sensor, which measures the internal temperature of the AD7689/82-16. Note that, when using the temperature sensor, the output is straight binary referenced AD7689/82-16 GND pin.

The internal reference is trimmed to provide a typical drift of ± 6 ppm/ $^{\circ}C$. Figure 34 shows the internal reference connection.

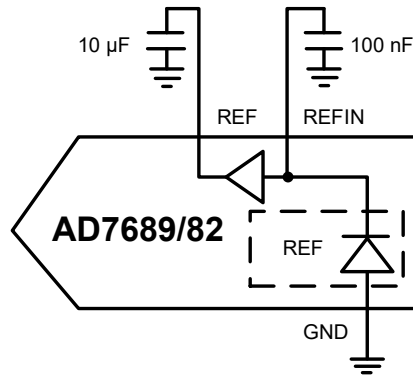

Figure 34. 2.5 V or 4.096 V Internal Reference Connection

External Reference and Internal Buffer

For improved drift performance, an external reference can be used with the internal buffer, as shown in Figure 35. The external source is connected to REFIN, the input to the on-chip unity gain buffer, and the output is produced on the REF pin to drive the ADC core. An external reference can be used with the internal buffer with or without the temperature sensor enabled.

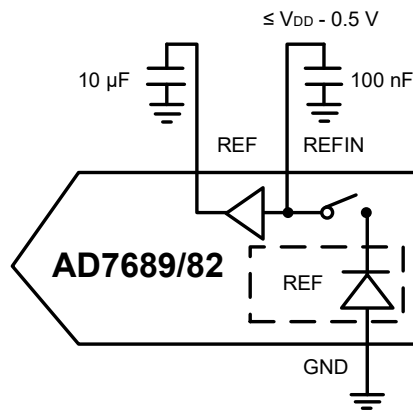

Figure 35. External Reference Using Internal Buffer

External Reference

For improved drift or noise performance, an external reference can be connected directly on the REF pin as shown in Figure 36. The reference buffer must be powered down, and the internal reference can be disabled for lower power consumption.

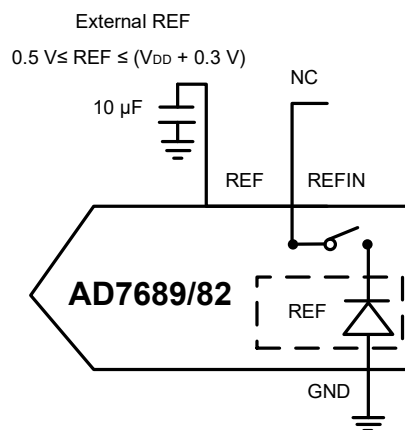

Figure 36. External Reference (internal buffer disabled)

For precision ADC applications, a precision voltage reference is an essential device. Generally, the reference source needs to have low initial error, low noise, and low temperature drift. The AD7689/82-16 reference voltage REF has a dynamic input impedance, so it should be driven with a low impedance source. The REF and GND pins should be effectively decoupled as described in the PCB Layout Guidelines section. Figure 37 shows an example of a specific voltage reference and driver design. The AD82X series of high-precision voltage references can just meet these requirements.

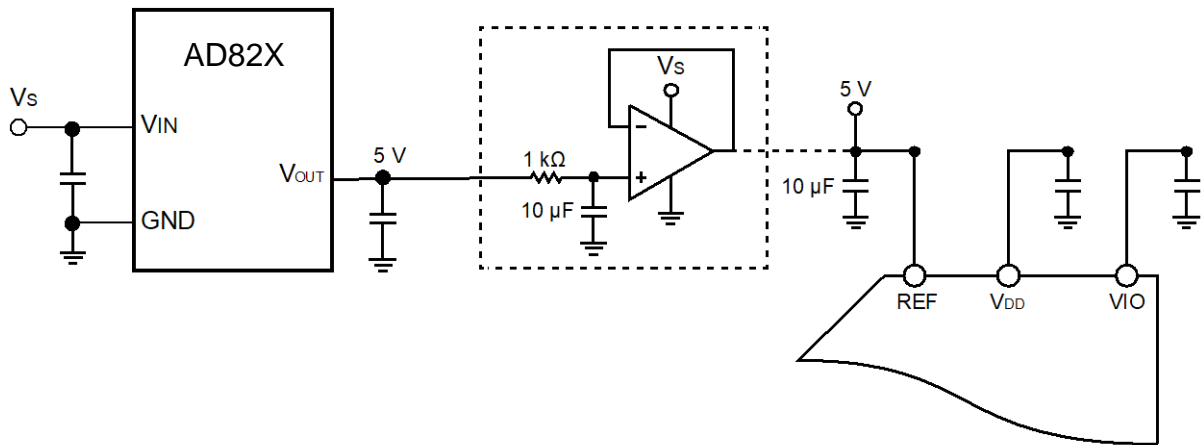

Figure 37. External Reference Drive

Power Supply

AD7689/82-16 uses two power supply pins: core power supply (V_{DD}) and digital input/output interface power supply VIO. VIO can directly interface with any logic from 1.8 V to V_{DD} . To reduce the number of power supplies required, the VIO and V_{DD} pins can be tied together via resistors or ferrite beads. The PSRR curve is shown in Figure 38.

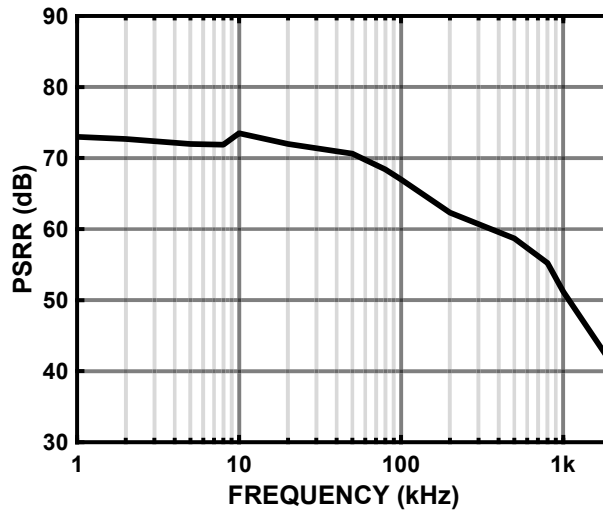

Figure 38. PSRR vs. Frequency

The AD7689/82-16 automatically enters power-down mode at the end of each conversion stage, so the power consumption is approximately linearly proportional to the sampling rate. This makes the device suitable for low sampling rate and low power consumption applications. As shown Figure 39.

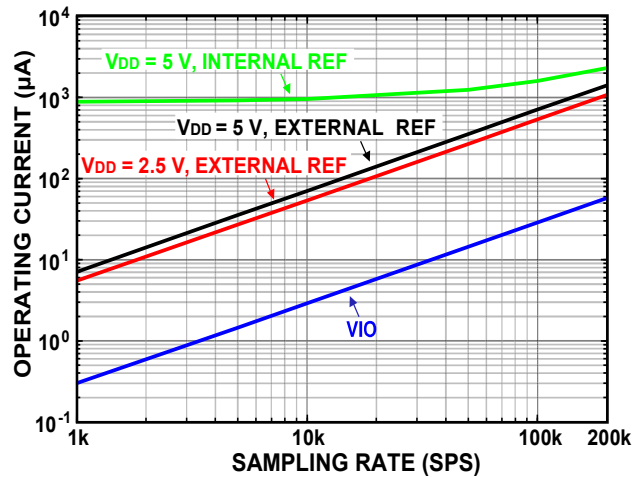

Figure 39. Operating Current vs. Sampling Rate

Digital Interface

AD7689/82-16 has 4-wire SPI digital interface which uses CNV, DIN, SCK and SDO. A 14-bit register, CFG [13 : 0], is used to configure the ADC for the channel to be converted, the reference selection, and other components.

When CNV is low (works like chip select), reading/writing can occur during conversion, acquisition, and spanning conversion (acquisition plus conversion), as detailed in the following sections. The CFG word is updated on the first 14 SCK rising edges, and conversion codes are output on the first 15 (or 16 if busy indicator is selected) SCK falling edges. If the CFG readback is enabled, an additional 14 SCK falling edges are required to output the CFG word following the conversion code with the CFG MSB following the LSB of the conversion code.

Reading/Writing During Conversion

When reading or writing during conversion (n), conversion results are for the previous (n - 1) conversion, and writing the CFG register is for the next (n + 1) acquisition and conversion. After the CNV is brought high to initiate conversion, it must be brought low again to allow reading or writing during conversion. Reading or writing should only occur up to t_{DATA} .

The SCK frequency required is calculated by

$$f_{SCK} \geq \frac{\text{Number_SCK_Edges}}{t_{DATA}}$$

The time between t_{DATA} and t_{CONV} is a quiet time when digital activity should not occur, or sensitive bit decisions may be corrupted.

Reading/Writing After Conversion

When reading or writing after conversion, or during acquisition (n), conversion results are for the previous (n - 1) conversion, and writing is for the (n + 1) acquisition. The reading or writing takes place during the t_{ACQ} (minimum) time.

Reading/Writing Spanning Conversion

When reading or writing spanning conversion, the data access starts at the current acquisition (n) and spans into the conversion (n). Conversion results are for the previous (n - 1) conversion, and writing the CFG register is for the next (n + 1) acquisition and conversion.

Configuration Register

The AD7689/82-16 uses a 14-bit configuration register (CFG [13 : 0]) to configure the analog inputs, the channel to be converted, the one-pole filter bandwidth, the reference, and the channel sequencer. The CFG register is latched (MSB first) on DIN with 14 SCK rising edges.

The register can be written to during conversion, during acquisition, or spanning acquisition/conversion, and is updated at the end of conversion. There is always a one deep delay when writing the CFG register. Note that, at power-up, the CFG register is undefined and two dummy conversions are required to update the register. To preload the CFG register with a factory setting, hold DIN high for two conversions. Thus CFG [13 : 0] = 0b11 1111 1111 1111. This sets the AD7689/82-16 for the following:

- IN [7 : 0] unipolar referenced to GND, sequenced in order
- Full bandwidth
- Internal reference and temperature sensor disabled, buffer enabled
- Internal sequencer enabled
- No readback of the CFG register

13	12	11	10	9	8	7	6	5	4	3	2	1	0
CFG	INCC	INCC	INCC	INX	INX	INX	BW	REF	REF	REF	SEQ	SEQ	RB

Configuration Register Description:

Bit	Name	Description
[13]	CFG	Configuration update. 0 = write invalid, keep current configuration settings. 1 = write enabled, overwrite contents of register.
[12 : 10]	INCC	Input channel configuration. Selection of pseudo differential bipolar, pseudo differential unipolar pairs, single-ended, or temperature sensor.
		12 11 10 Function
		0 0 X ¹ Pseudo differential bipolar pairs; INx- input is $V_{REF} / 2 \pm 0.1 V$.
		0 1 0 Pseudo differential bipolar pairs; INx- is COM = $V_{REF} / 2 \pm 0.1 V$.
		0 1 1 Temperature sensor.
		1 0 X Pseudo differential unipolar pairs; INx- input is $GND \pm 0.1 V$.
		1 1 0 Pseudo differential unipolar pairs; INx- is COM = $GND \pm 0.1 V$.
1 1 1 Singled-ended; INx referenced to GND.		
[9 : 7]	INx	Input channel selection.
		AG7689 -16 AD7682 -16
		9 8 7 Channel selected.
		0 0 0 IN0
		0 0 1 IN1
	
1 1 1 IN7		
[6]	BW	Selection of bandwidth for low-pass filter. 0 = $\frac{1}{4}$ BW, an additional internal series resistor to limit the noise. Maximum throughput must be reduced to $\frac{1}{4}$. 1 = Full bandwidth.
[5 : 3]	REF	Reference or buffer selection. Selection of internal, external, external buffered, and enabling of the on-chip temperature sensor.
		5 4 3 Function
		0 0 0 Internal reference and temperature sensor enabled. REF = 2.5 V buffered output.
		0 0 1 Internal reference and temperature sensor enabled. REF = 4.096 V buffered output.
		0 1 0 Use external reference on REF. Temperature sensor enabled. Internal buffer disabled.
		0 1 1 Use external reference on REFIN. Temperature sensor enabled. Internal buffer enabled.
		1 0 0 Invalid.
		1 0 1 Invalid.
1 1 0 Use external reference on REF. Temperature sensor disable, internal reference disabled and internal buffer disabled.		
1 1 1 Use external reference on REFIN. Temperature sensor disable, internal reference disabled and internal buffer enabled.		
[2 : 1]	SEQ	Channel sequencer. Allows for scanning channels in an IN0 to IN [7 : 0] fashion.
		2 1 Function
		0 0 Disable sequencer.
		0 1 No effect.
		1 0 Scan IN0 to IN [7 : 0] (set in CFG [9 : 7]), then temperature.
1 1 Scan IN0 to IN [7 : 0] (set in CFG [9 : 7])		
[0]	RB	Read back the CFG register. 0 = Read back current configuration at end of code. 1 = Do not read back current configuration at end of code.

¹ X = do not care

General Timing Without a Busy Indicator

Figure 40 details the timing for all three modes: read/write during conversion (RDC), read/write after conversion (RAC), and read/write spanning conversion (RSC). Note that the gating item for both CFG and code readback is at the end of conversion (EOC). Make sure CNV is high at EOC, so the busy indicator is disabled.

The data access should happen during the safe data reading/writing time, t_{DATA} . If the full CFG word was not written to before EOC, it is discarded and the current configuration remains. If the conversion result is not read out fully prior to EOC, it is lost as the ADC updates SDO with the MSB of the current conversion. When CNV is brought low after EOC, SDO is driven from high impedance to the MSB. Falling SCK edges clock out bits starting with MSB - 1. The SCK can idle high or low.

From power-up, in any read/write mode, the first three conversion results are undefined because a valid CFG does not take place until the 2nd EOC; thus two dummy conversions are required. Also, if the state machine writes the CFG during the power-up state (RDC shown), the CFG register needs to be rewritten again at the next phase. Note that the first valid data occurs in Phase (n + 1) when the CFG register is written during Phase (n - 1).

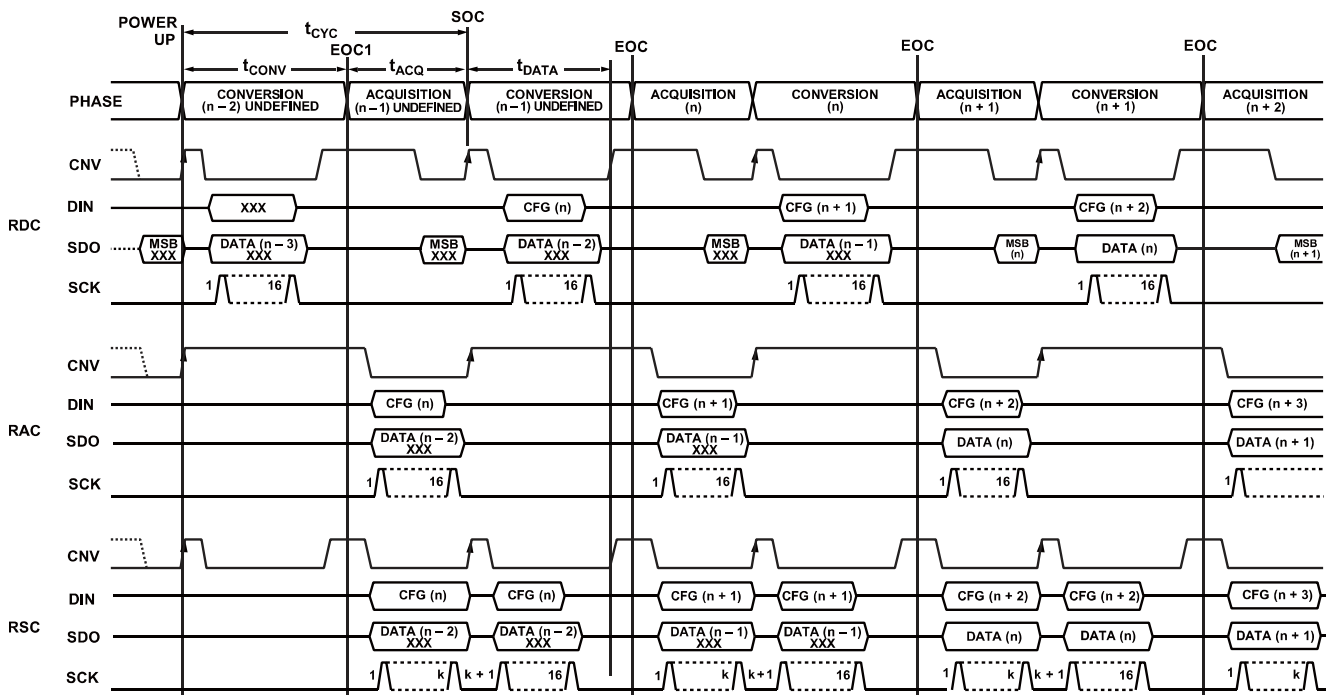

Note: $n = 16$ for no readback of CFG; $n = 30$ for readback of CFG

Figure 40. General Interface Timing for the AD7689/82-16 Without a Busy Indicator

General Timing with a Busy Indicator

Figure 41 details the timing for all three modes: read/write during conversion (RDC), read/write after conversion (RAC), and read/write spanning conversion (RSC). If CNV is low at EOC, the busy indicator is enabled. In addition, to generate the busy indicator properly, the host must provide a minimum of 15 SCK falling edges to return SDO to high impedance because the last bit on SDO remains active.

From power-up, in any read/write mode, the first three conversion results are undefined because a valid CFG does not take place until the 2nd EOC; thus two dummy conversions are required. If the host writes the CFG during the power-up state (RDC shown), the CFG register needs to be rewritten again at the next phase. Note that the first valid data occurs in Phase (n + 1) when the CFG register is written during Phase (n - 1).

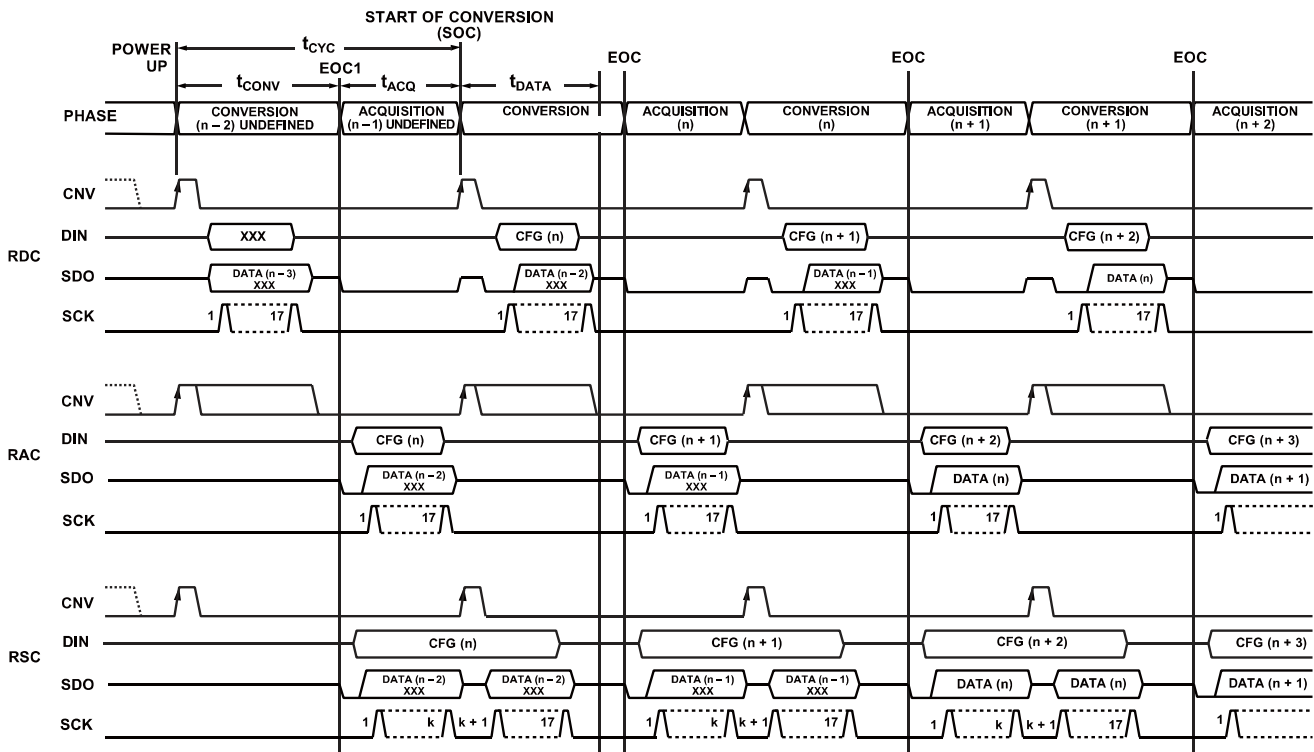

Note: $n = 17$ for no readback of CFG; $n = 31$ for readback of CFG
 Figure 41. General Interface Timing for the AD7689/82-16 With a Busy Indicator

Channel Sequencer

AD7689/82-16 channels can be scanned as singles or pairs, with or without the temperature sensor.

The sequencer starts with IN0 and ends with IN [7 : 0] set in CFG [9 : 7]. For paired channels, the channels are paired depending on the last channel set in CFG [9 : 7]. Note that in sequencer mode, the channels are always paired with the positive input on the even channels (IN0, IN2, IN4, IN6), and with the negative input on the odd channels (IN1, IN3, IN5, IN7).

Figure 42 shows the timing for all three modes without a busy indicator. The sequencer can also be used with the busy indicator.

For sequencer operation, the CFG register should be set during the (n - 1) phase. On phase (n), the sequencer setting takes place and acquires IN0. The first valid conversion code is available at phase (n + 1). After the last channel set in CFG [9 : 7] is converted, the internal temperature sensor data is output (if enabled), followed by acquisition of IN0.

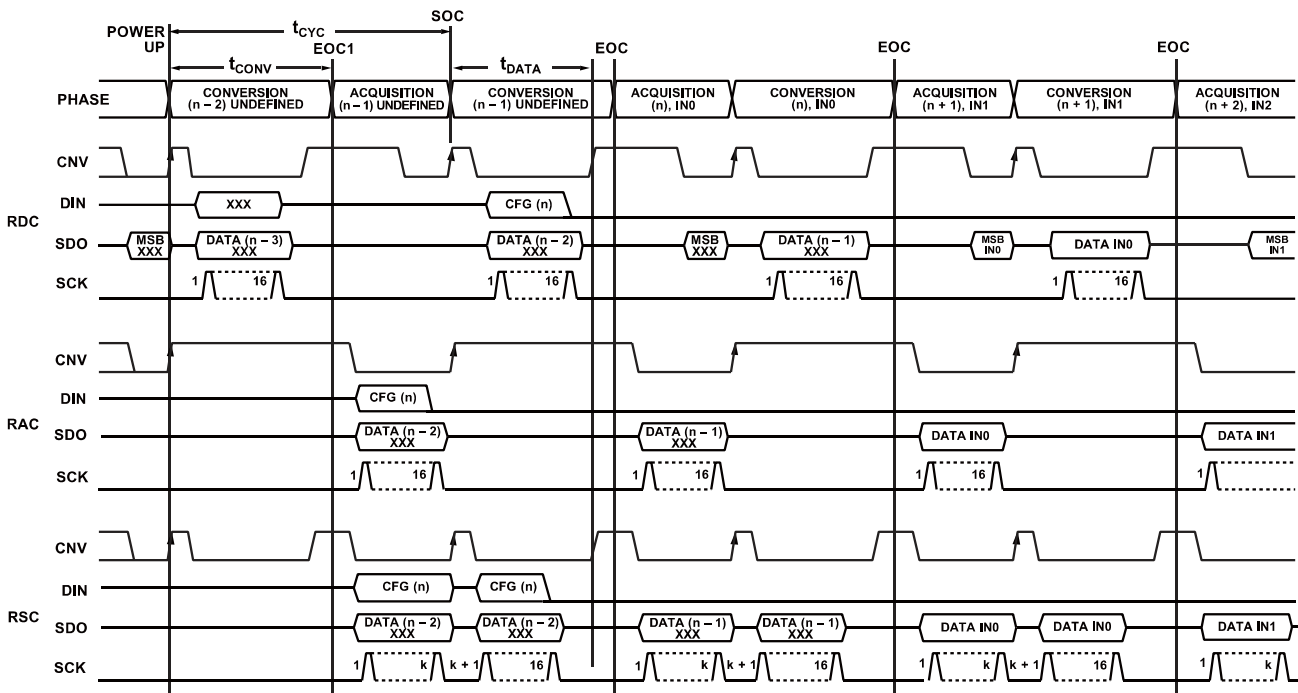

Figure 42. General Channel Sequencer Timing Without a Busy Indicator

RAC Without a Busy Indicator

AD7689/82-16 connects to the host as shown in Figure 43, and the timing is shown is Figure 44

A rising edge on CNV initiates a conversion, pushes SDO to high impedance, and ignores data present on DIN. After a conversion is initiated, it continues until completion independent of the state of CNV. CNV must be returned high before the t_{DATA} elapses, and then held high beyond the conversion time t_{CONV} , to avoid the busy indicator generation.

After the conversion is complete, the AD7689/82-16 enters the acquisition phase and powers down. While CNV is low, both a CFG update and a data readback take place. The first 14 SCK rising edges are used to update the CFG, and the first 15 SCK falling edges clock out the conversion results starting with MSB - 1. All 14 bits of CFG [13 : 0] must be written, otherwise they are ignored.

After the 16th (or 30th) SCK falling edge, or when CNV goes high (whichever happens first), SDO returns to high impedance.

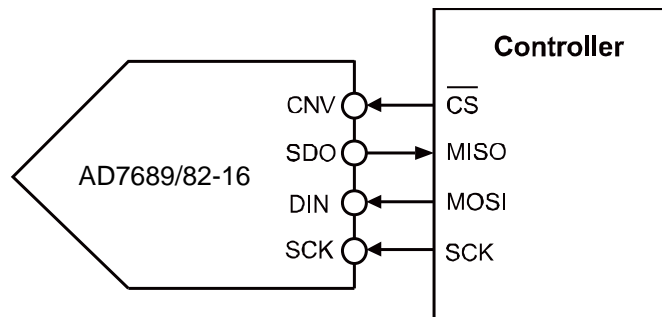

Figure 43. Connection without a Busy Indicator

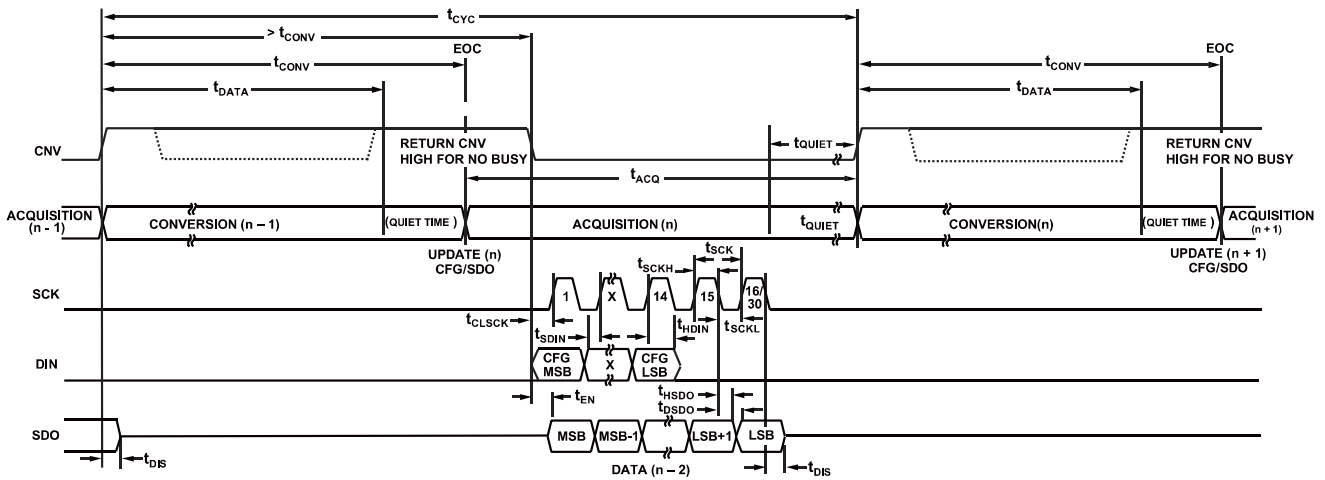

Figure 44. Timing of RAC without a Busy Indicator

RAC with a Busy Indicator

AD7689/82-16 connects to the host as shown in Figure 45, and the timing is shown is Figure 46.

A rising edge on CNV initiates a conversion, pushes SDO to high impedance, and ignores data present on DIN. After a conversion is initiated, it continues until completion independent of the state of CNV. CNV must be returned low before the t_{DATA} elapses, and then held low beyond the conversion time t_{CONV} , to generate the busy indicator.

After the conversion is complete, the AD7689/82-16 enters the acquisition phase and powers down. While CNV is low, both a CFG update and a data readback take place. The first 14 SCK rising edges are used to update the CFG, and the first 16 SCK falling edges clock out the conversion results. All 14 bits of CFG [13 : 0] must be written, otherwise they are ignored.

After the 17th (or 31st) SCK falling edge, or when CNV goes high (whichever happens first), SDO returns to high impedance.

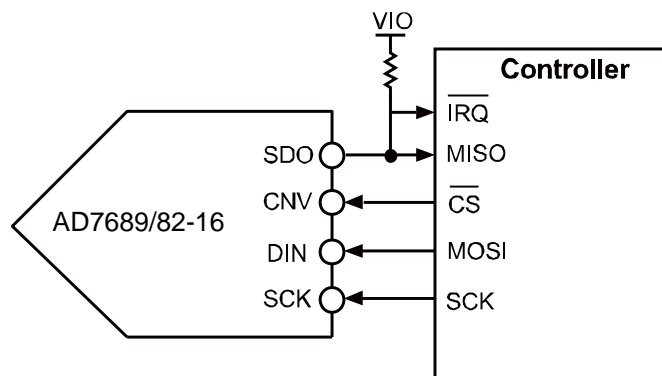

Figure 45. Connection with a Busy Indicator

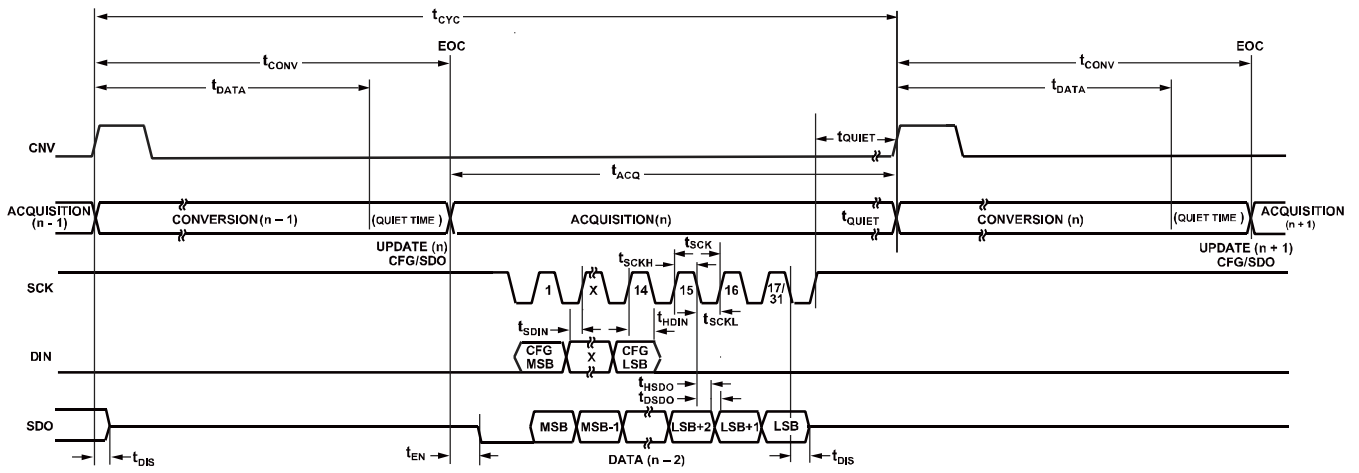

Figure 46. Timing of RAC with a Busy Indicator

Layout Guidelines

For optimum performance of the device, good PCB layout practices are recommended, including:

- Avoid running digital lines under the device, which may couple noise onto the die, unless a ground plane under the AD7689/82-16 is used as a shield. Fast switching signals such as CNV or clocks should not be placed close to the analog signal path. Crossover of digital and analog signals should be avoided.
- At least one ground plane should be used. It can be common or split between the digital and analog sections. In the latter case, the planes should be joined close to the AD7689/82-16.
- The AD7689/82-16 external voltage reference input, REF, has a dynamic input impedance and should be decoupled with 10 μF ceramic capacitors to minimize parasitic inductances. This is done by placing the reference decoupling ceramic capacitor close to, ideally right up against, the REF and GND pins and connecting them with wide, low impedance trace.
- The power supply V_{DD} of AD7689/82-16 should be decoupled with 10 μF and 100 nF ceramic capacitors, placed close to the AD7689/82-16 and connected using short, wide traces to provide low impedance paths and to reduce the effect of noises on the power supply lines.

Figure 47 is an example of the guidance.

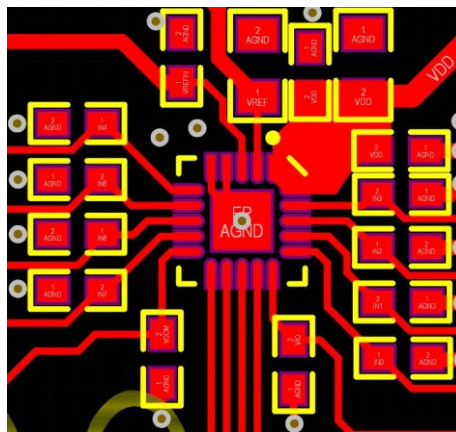

Figure 47. Example Layout and Routing of AD7689/82-16

Outline Dimensions

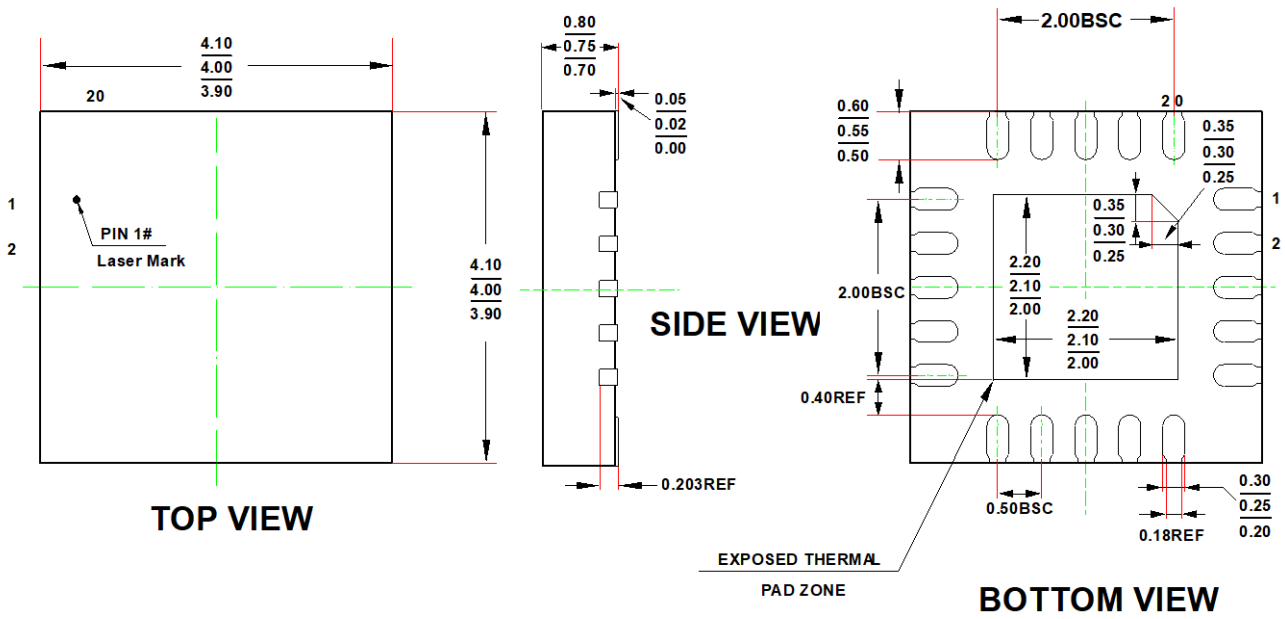

Figure 48. 20-Lead QFN Package Dimensions Shown in Millimeter

Ordering Guide

Model	Orderable Device	Status ¹	Resolution (bit)	Supply Voltage (V)	Temperature Range (°C)	Package	External Package
AD7689 -16	AD7689BCPZ	ACTIVE	16	2.3 to 5.5	-40 to +85	QFN-20	13" Reel
AD7682 -16	AD7682BCPZ	ACTIVE					