

**N-Ch 150V Fast Switching MOSFETs**
**General Description**

- 100% EAS Guaranteed
- Green Device Available
- Super Low  $R_{DS(ON)}$
- Advanced high cell density Trench technology

**Applications**

- MOTOR Driver.
- UPS.
- Power Tools.
- Synchronous Rectification in SMPS.

**Product Summary**

$V_{DS}$	150	V
$R_{DS(ON),typ}$	4	m $\Omega$
$I_D$	190	A

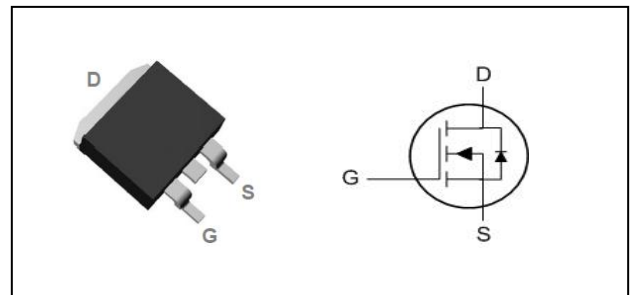
**TO-263 Pin Configuration**

**Absolute Maximum Ratings**

Symbol	Parameter	Rating	Units
$V_{DS}$	Drain-Source Voltage	150	V
$V_{GS}$	Gate-Source Voltage	$\pm 20$	V
$I_D@T_C=25^\circ\text{C}$	Continuous Drain Current, $V_{GS} @ 10V^{1,6}$	190	A
$I_D@T_C=100^\circ\text{C}$	Continuous Drain Current, $V_{GS} @ 10V^{1,6}$	135	A
$I_{DM}$	Pulsed Drain Current <sup>2</sup>	760	A
EAS	Single Pulse Avalanche Energy <sup>3</sup>	890	mJ
$P_D@T_C=25^\circ\text{C}$	Total Power Dissipation <sup>4</sup>	410	W
$T_{STG}$	Storage Temperature Range	-55 to 175	$^\circ\text{C}$
$T_J$	Operating Junction Temperature Range	-55 to 175	$^\circ\text{C}$

**Thermal Data**

Symbol	Parameter	Typ.	Max.	Unit
$R_{\theta JA}$	Thermal Resistance Junction-Ambient <sup>1</sup>	---	55	$^\circ\text{C/W}$
$R_{\theta JC}$	Thermal Resistance Junction-Case <sup>1</sup>	---	0.36	$^\circ\text{C/W}$

**N-Ch 150V Fast Switching MOSFETs**
**Electrical Characteristics (T<sub>J</sub>=25 °C, unless otherwise noted)**

Symbol	Parameter	Conditions	Min.	Typ.	Max.	Unit
BV <sub>DSS</sub>	Drain-Source Breakdown Voltage	V <sub>GS</sub> =0V, I <sub>D</sub> =250uA	150	---	---	V
R <sub>DS(ON)</sub>	Static Drain-Source On-Resistance <sup>2</sup>	V <sub>GS</sub> =10V, I <sub>D</sub> =20A	---	4.0	5.0	mΩ
V <sub>GS(th)</sub>	Gate Threshold Voltage	V <sub>GS</sub> =V <sub>DS</sub> , I <sub>D</sub> =250uA	2.0	3.0	4.0	V
I <sub>DSS</sub>	Drain-Source Leakage Current	V <sub>DS</sub> =120V, V <sub>GS</sub> =0V, T <sub>J</sub> =25°C	---	---	1	uA
		V <sub>DS</sub> =120V, V <sub>GS</sub> =0V, T <sub>J</sub> =55°C	---	---	5	
I <sub>GSS</sub>	Gate-Source Leakage Current	V <sub>GS</sub> =±20V, V <sub>DS</sub> =0V	---	---	±100	nA
R <sub>g</sub>	Gate Resistance	V <sub>DS</sub> =0V, V <sub>GS</sub> =0V, f=1MHz	---	4.9	---	Ω
Q <sub>g</sub>	Total Gate Charge (10V)	V <sub>DS</sub> =75V, V <sub>GS</sub> =10V, I <sub>D</sub> =20A	---	128	---	nC
Q <sub>gs</sub>	Gate-Source Charge		---	83	---	
Q <sub>gd</sub>	Gate-Drain Charge		---	44	---	
T <sub>d(on)</sub>	Turn-On Delay Time	V <sub>DD</sub> =75V, V <sub>GS</sub> =10V, R <sub>G</sub> =4.5Ω, R <sub>L</sub> =1Ω, I <sub>D</sub> =20A	---	33	---	ns
T <sub>r</sub>	Rise Time		---	68	---	
T <sub>d(off)</sub>	Turn-Off Delay Time		---	85	---	
T <sub>f</sub>	Fall Time		---	41	---	
C <sub>iss</sub>	Input Capacitance	V <sub>DS</sub> =75V, V <sub>GS</sub> =0V, f=1MHz	---	8660	---	pF
C <sub>oss</sub>	Output Capacitance		---	720	---	
C <sub>rss</sub>	Reverse Transfer Capacitance		---	28	---	

**Diode Characteristics**

Symbol	Parameter	Conditions	Min.	Typ.	Max.	Unit
V <sub>SD</sub>	Diode Forward Voltage <sup>2</sup>	V <sub>GS</sub> =0V, I <sub>S</sub> =50A, T <sub>J</sub> =25°C	---	---	1.1	V
t <sub>rr</sub>	Reverse Recovery Time	I <sub>F</sub> =15A, dI/dt=100A/μs, T <sub>J</sub> =25°C	---	118	---	nS
Q <sub>rr</sub>	Reverse Recovery Charge		---	431	---	nC

Note :

- 1.The data tested by surface mounted on a 1 inch<sup>2</sup> FR-4 board with 2OZ copper.
- 2.The data tested by pulsed , pulse width ≤ 300us , duty cycle ≤ 2%
- 3.The power dissipation is limited by 150°C junction temperature
- 4.The EAS data shows Max. rating . The test condition is V<sub>DD</sub>=75V, V<sub>GS</sub>=10V, L=0.3mH, I<sub>AS</sub> = 75A.
- 5.The data is theoretically the same as I<sub>D</sub> and I<sub>DM</sub> , in real applications , should be limited by total power dissipation.
- 6.Package limitation current.

**Typical Characteristics**

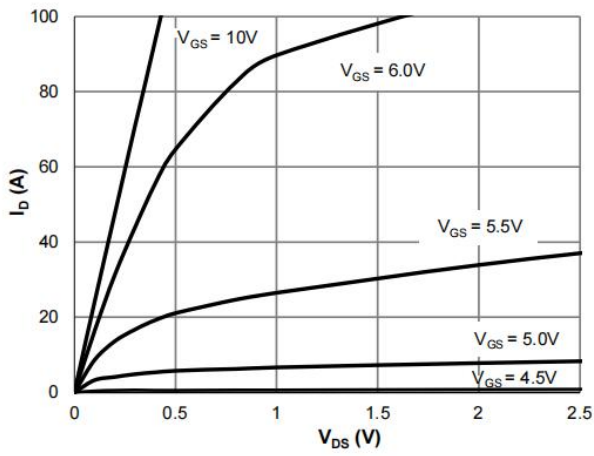

**Figure 1: Saturation Characteristics**

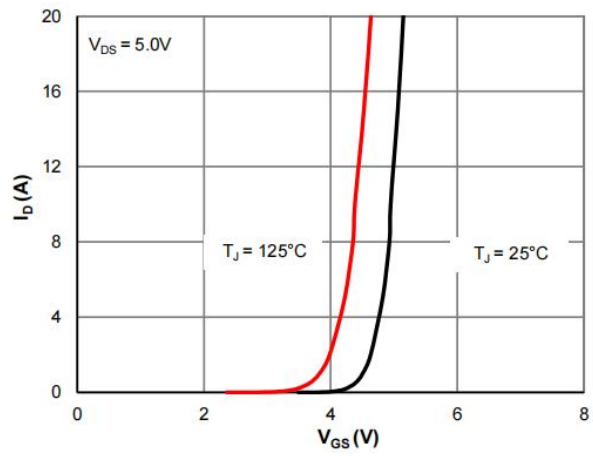

**Figure 2: Transfer Characteristics**

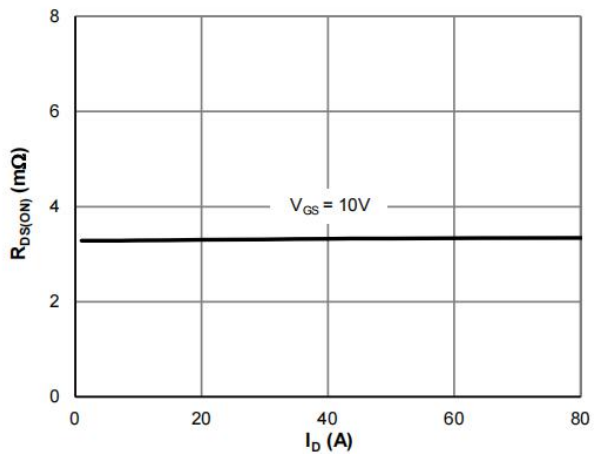

**Figure 3:  $R_{DS(ON)}$  vs. Drain Current**

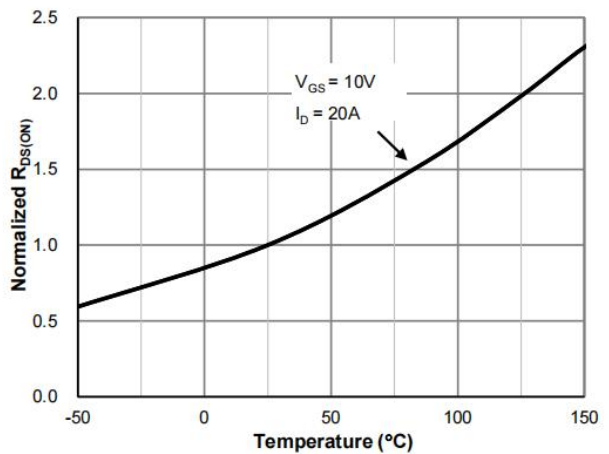

**Figure 4:  $R_{DS(ON)}$  vs. Junction Temperature**

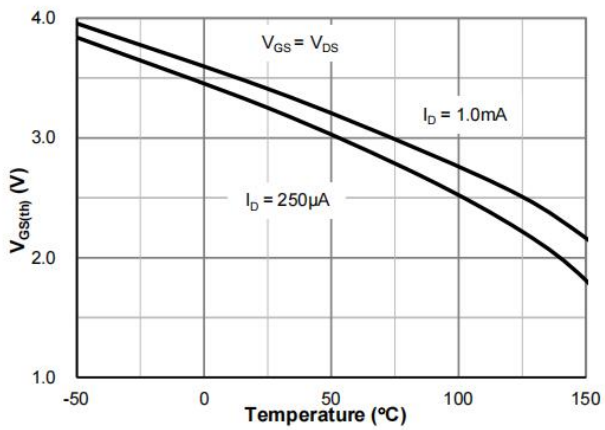

**Figure 5:  $V_{GS(th)}$  vs. Junction Temperature**

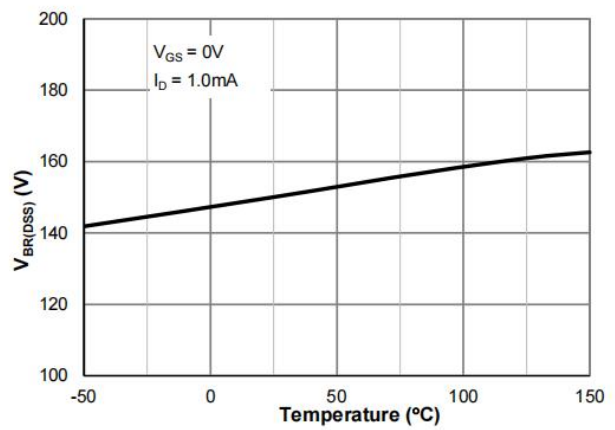

**Figure 6:  $V_{BR(DSS)}$  vs. Junction Temperature**

**N-Ch 150V Fast Switching MOSFETs**

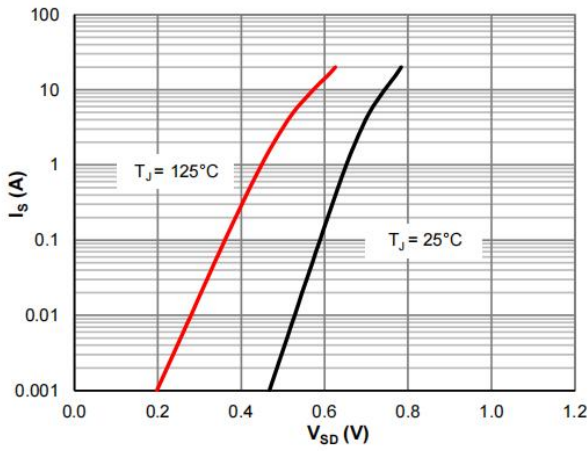

Figure 7: Body-Diode Characteristics

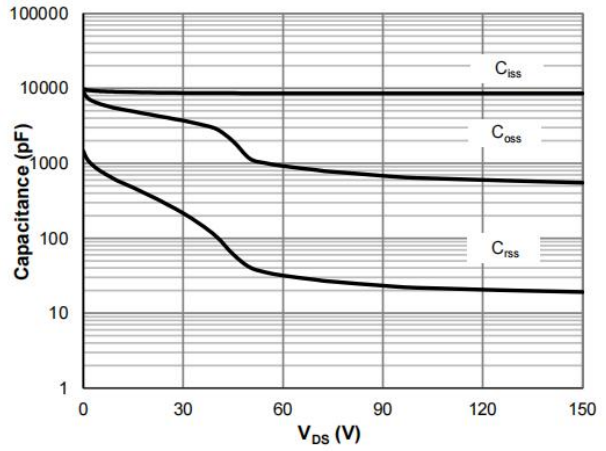

Figure 8: Capacitance Characteristics

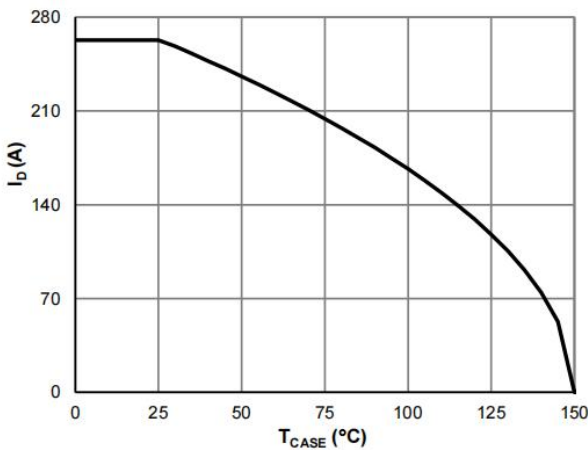

Figure 9: Current De-rating

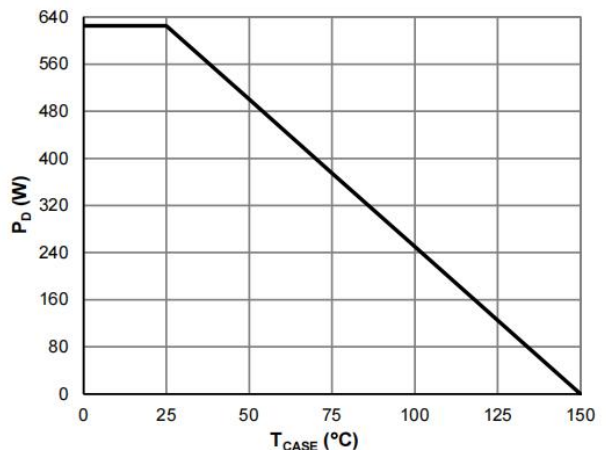

Figure 10: Power De-rating

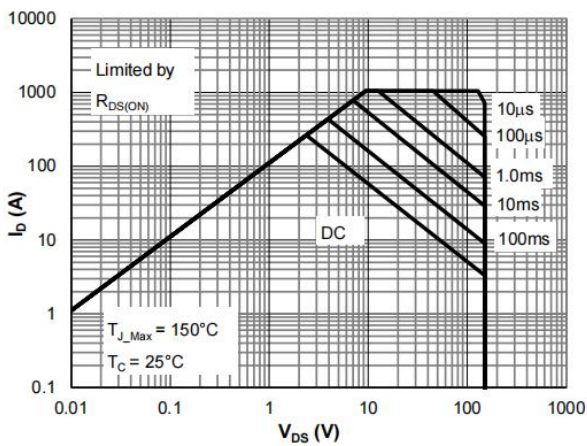

Figure 11: Maximum Safe Operating Area

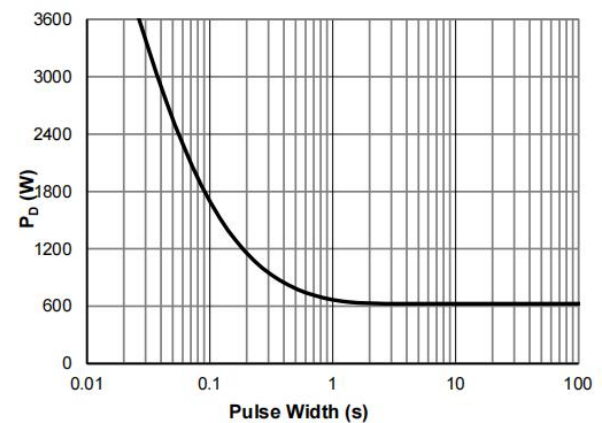
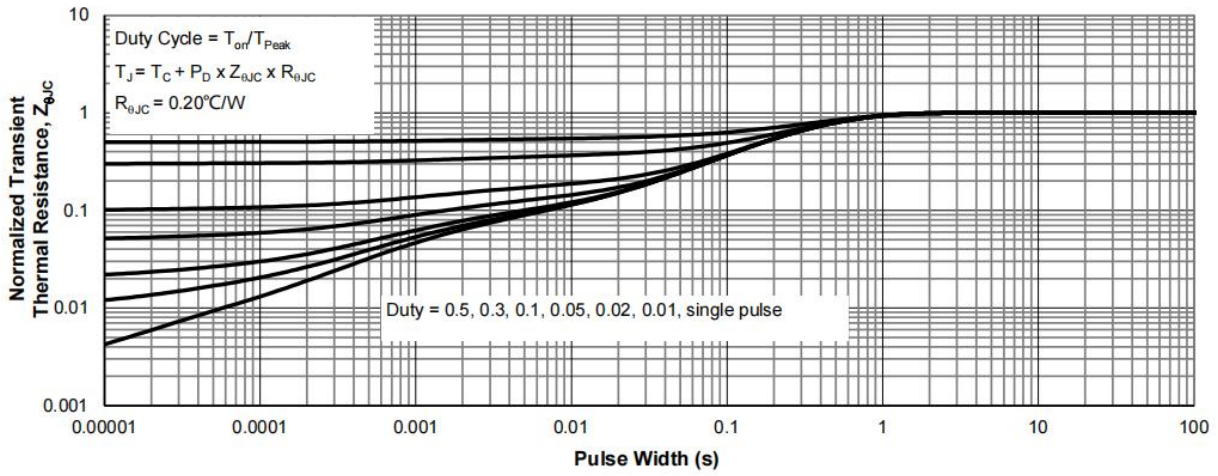
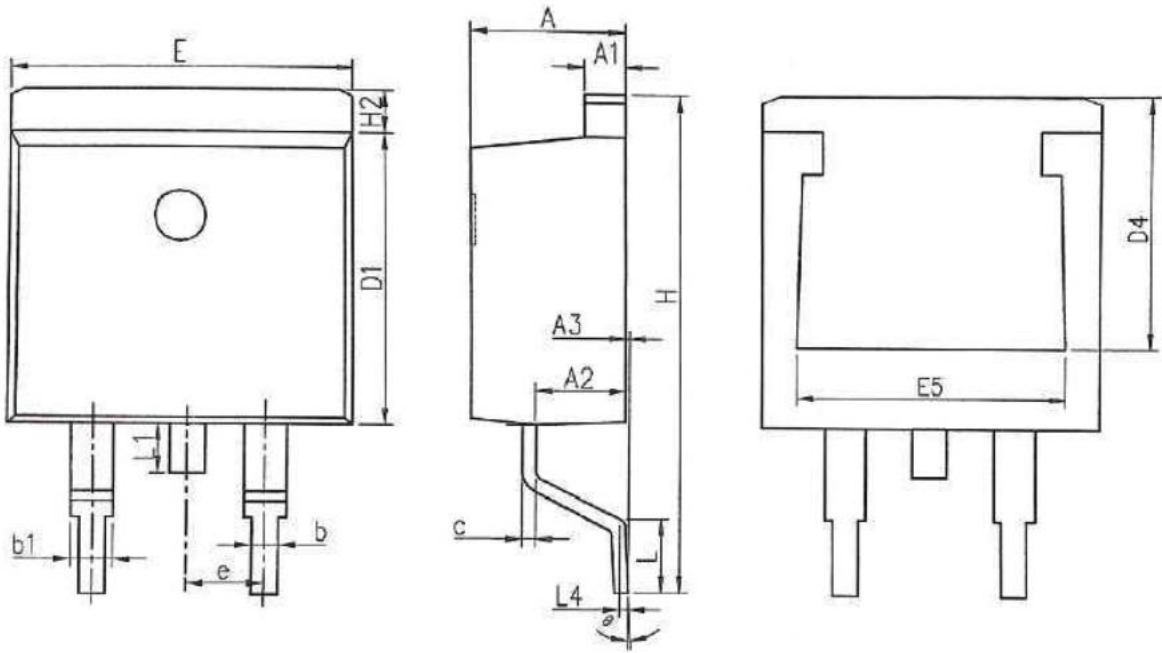

Figure 12: Single Pulse Power Rating, Junction-to-Case



**Figure 13: Normalized Maximum Transient Thermal Impedance**



SYMBOLS	MILLIMETERS		INCHES	
	MIN	MAX	MIN	MAX
A	4.370	4.770	0.172	0.188
A1	1.220	1.420	0.048	0.056
A2	2.200	2.890	0.087	0.114
A3	0.000	0.250	0.000	0.010
b	0.700	0.960	0.028	0.038
b1	1.170	1.470	0.046	0.058
c	0.300	0.530	0.012	0.021
D1	8.500	9.300	0.335	0.366
D4	6.600	-	0.260	-
E	9.860	10.36	0.388	0.408
E5	7.060	-	0.278	-
e	2.540 BSC		0.100 BSC	
H	14.70	15.70	0.579	0.618
H2	1.070	1.470	0.042	0.058
L	2.000	2.600	0.079	0.102
L1	1.400	1.750	0.055	0.069
L4	0.250 BSC		0.010 BSC	
Θ	0°	9°	0°	9°