

Low-Drift, Low-Power, Small-Footprint Series Voltage Reference

Features

- Low Noise (0.1 Hz to 10 Hz): 2.5 ppm_{peak-peak}
- Low Temperature Coefficient: 5 ppm/°C max
- Initial Accuracy: ±0.05% max
- Quiescent Current: 130 µA
Shutdown Current: 3 µA
- Supply Voltage: $V_{OUT} + 0.3\text{ V}$ to 5.5 V
- Line Regulation: 10 ppm/V max
- Load Regulation: 10 ppm/mA max
- Small Package: SOT23-6
- Temperature Range: -40 °C to +125 °C
- ZJR1001 has Noise Filter Option
- Pin Compatible with Industry Standard Products Pins

Applications

- Industrial Control
- Precision Data Acquisition
- Optical Communication
- Precision Instrument
- Smart Grid
- Medical Equipment
- Portable Devices

Typical Application

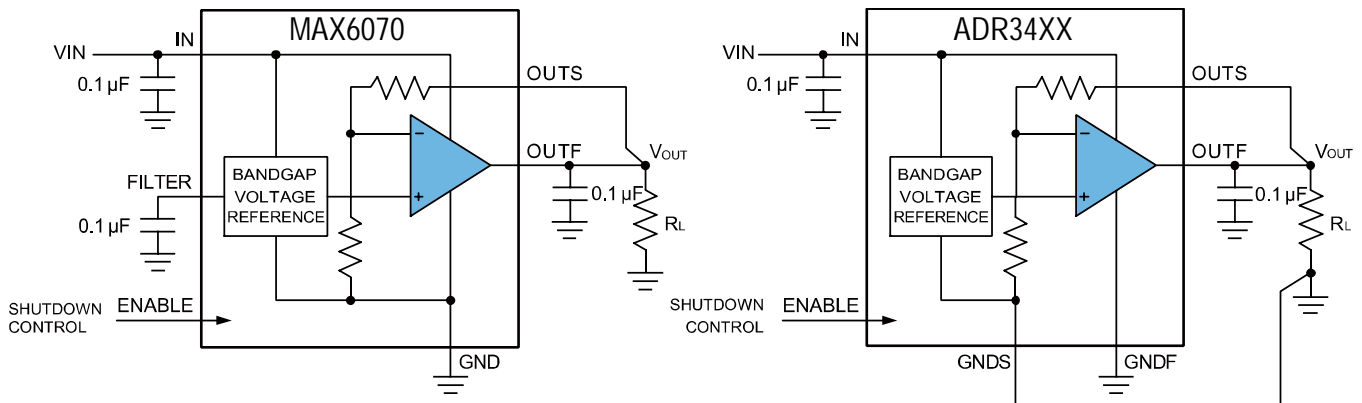

temperature range of

Model	Output Voltage (V)
ADR3420ARJZ-R7	2.048
MAX6070BAUT25 ADR3425ARJZ-7R	2.5
MAX6070BAUT30 ADR3430ARJZ-7R	3
ADR3433ARJZ-7R	3.3
MAX6070BAUT40 ADR3440ARJZ-7R	4.096
MAX6070BAUT50 ADR3450ARJZ-7R	5

Pin Configurations and Function Descriptions

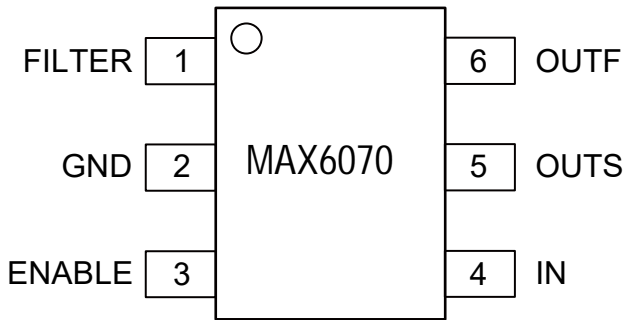

Figure 1. MAX6070 Pin Configuration (6-lead SOT23)

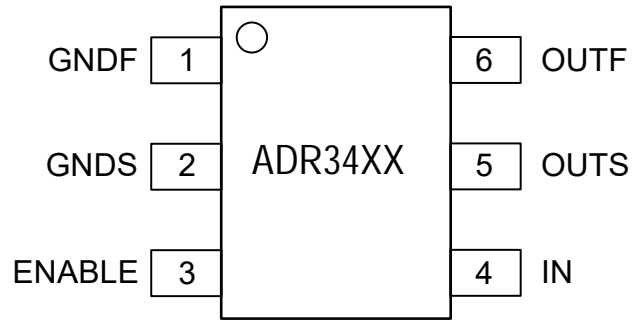

Figure 2. ADR34XX Pin Configuration (6-lead SOT23)

Mnemonic	Pin No.	Description
FILTER	1	Filter Input. Connect a 0.1 μF capacitor from FILTER to ground to provide high-frequency bypass. Leave unconnected, if not used.
GND	2	Ground
ENABLE	3	Enable. Drive high to enable the device. Drive low to disable the device.
IN	4	Supply voltage input
OUTS	5	Voltage Reference Sense Output
OUTF	6	Voltage Reference Force Output. Short OUTF to OUTS as close as possible to the load. Bypass OUTF with a capacitor (0.1 μF to 10 μF) to GND.

Mnemonic	Pin No.	Description
GNDF	1	Ground Force
GNDS	2	Ground Sense. Connect to ground connection at the load.
ENABLE	3	Enable. Drive high to enable the device. Drive low to disable the device.
IN	4	Supply voltage input
OUTS	5	Voltage Reference Sense Output
OUTF	6	Voltage Reference Force Output. Short OUTF to OUTS as close as possible to the load. Bypass OUTF with a capacitor (0.1 μF to 10 μF) to GND.

Absolute Maximum Ratings ¹

Parameter	Rating
Input Voltage	-0.2 V to 6 V
Output Short-Circuit Current to GND	±30 mA
Operating Temperature Range	-40 °C to +125 °C
Storage Temperature Range	-65 °C to +150 °C
Junction Temperature Range	-65 °C to +150 °C
Maximum Reflow Temperature	260 °C
Lead Temperature (Soldering, 10 sec)	300 °C
Electrostatic Discharge (ESD)	
Human Body Model (HBM)	8 kV
Charging Device Model (CDM)	1 kV

Thermal Resistance ⁶

Package Type	θ_{JA}	θ_{JC}	Unit
SOT23-6	230	76	°C/W

Specifications¹

The “•” denotes the specification which apply over the full specified temperature range, unless otherwise specified, $V_{IN} = 2.8\text{ V to }5.5\text{ V}$, $I_{LOAD} = 0$, $C_L = 0.1\ \mu\text{F}$, $T_A = 25\ ^\circ\text{C}$.

Parameter	Symbol	Conditions/Package	Min	Typ.	Max	Unit	
Output Voltage	V_{OUT}	ADR3420		2.048		V	
		MAX6070/ADR3425		2.5		V	
		MAX6070/ADR3430		3		V	
		ADR3433		3.3		V	
		MAX6070/ADR3440		4.096		V	
		MAX6070/ADR3450		5		V	
Initial Accuracy			-0.05		+0.05	%	
Temperature Coefficient	TCV_{OUT}						
B Grade		•			5	ppm/ $^\circ\text{C}$	
A Grade		•			8	ppm/ $^\circ\text{C}$	
Voltage Noise	$e_{n\text{p-p}}$	0.1 Hz to 10 Hz		2.5		ppm_peak-to-peak	
Voltage Noise Density	e_n	MAX6070, $C_{FILTER} = 0.1\ \mu\text{F}$, $f = 1\ \text{kHz}$		60		nV/ $\sqrt{\text{Hz}}$	
		ADR3425, $f = 1\ \text{kHz}$		200		nV/ $\sqrt{\text{Hz}}$	
		MAX6070, $C_{FILTER} = 0.1\ \mu\text{F}$, $f = 1\ \text{kHz}$		92		nV/ $\sqrt{\text{Hz}}$	
		ADR3430, $f = 1\ \text{kHz}$		250		nV/ $\sqrt{\text{Hz}}$	
		MAX6070, $C_{FILTER} = 0.1\ \mu\text{F}$, $f = 1\ \text{kHz}$		85		nV/ $\sqrt{\text{Hz}}$	
		ADR3440, $f = 1\ \text{kHz}$		320		nV/ $\sqrt{\text{Hz}}$	
		MAX6070, $C_{FILTER} = 0.1\ \mu\text{F}$, $f = 1\ \text{kHz}$		108		nV/ $\sqrt{\text{Hz}}$	
		ADR3450, $f = 1\ \text{kHz}$		380		nV/ $\sqrt{\text{Hz}}$	
Line Regulation			•	2	10	ppm/V	
				5		ppm/V	
Load Regulation		-10 mA < I_{LOAD} < 10 mA	•	1.5	10	ppm/mA	
				6		ppm/mA	
Supply Voltage	V_{IN}	$I_{LOAD} = 5\ \text{mA}$, output voltage error < 0.1%					
		MAX6070/ADR3420	•	2.8		5.5	V
		Others	•	$V_{OUT} + 0.3$		5.5	V
Supply Current	I_Q		•	130		μA	
Shut down Current			•	3		μA	
Dropout Voltage		$I_{LOAD} = 0$	•	5		mV	
		$I_{LOAD} = 5\ \text{mA}$	•	50		mV	

¹ Each parameter is explained in the terminology section of this data sheet.

Parameter	Symbol	Conditions/Package	Min	Typ.	Max	Unit
Enable Pin (ENABLE)		Input Current	-1		1	μA
		Logic High Voltage	2			V
		Logic Low Voltage			0.8	V
Short-Circuit Current	I_L	$V_{OUT} = \text{GND} / V_{IN}$	16	20		mA
Ripple Rejection Ratio		Frequency = 60 Hz		-95		dB
Turn-on Settling Time		Stable to 0.1%, $C_L = 0.1 \mu\text{F}$		220		μs
Long-Term Stability ²		1000 hours, SOT23-6		-30		ppm/1000 hours
Temperature Range		Specified Temperature Range	-40		125	$^{\circ}\text{C}$
		Operating Temperature Range	-55		125	$^{\circ}\text{C}$

Typical Performance Characteristics

Unless otherwise stated, $V_{IN} = 2.8V$ to $5.5V$, $I_{LOAD} = 0$, $C_L = 0.1 \mu F$, $T_A = 25^\circ C$.

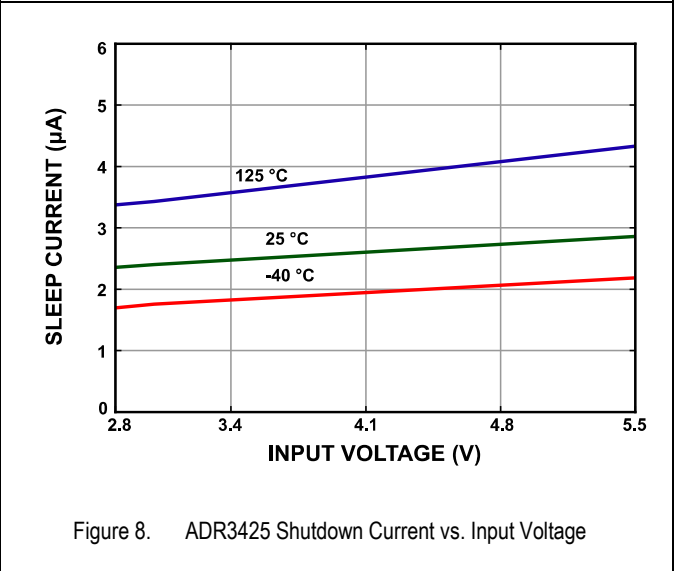
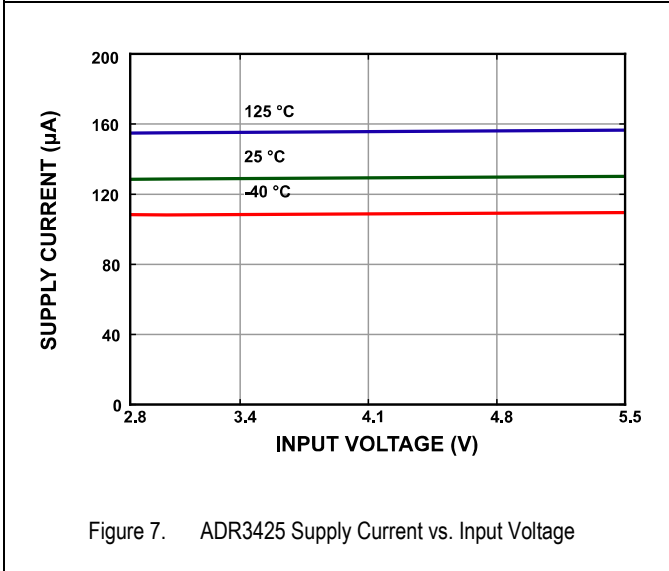
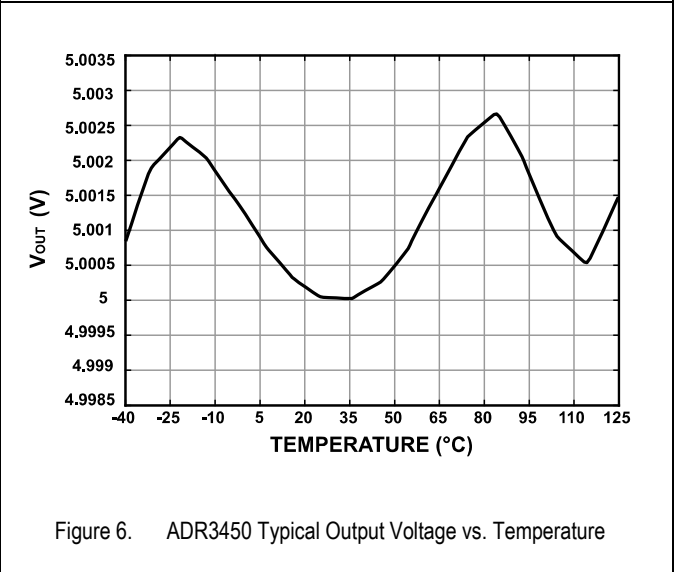
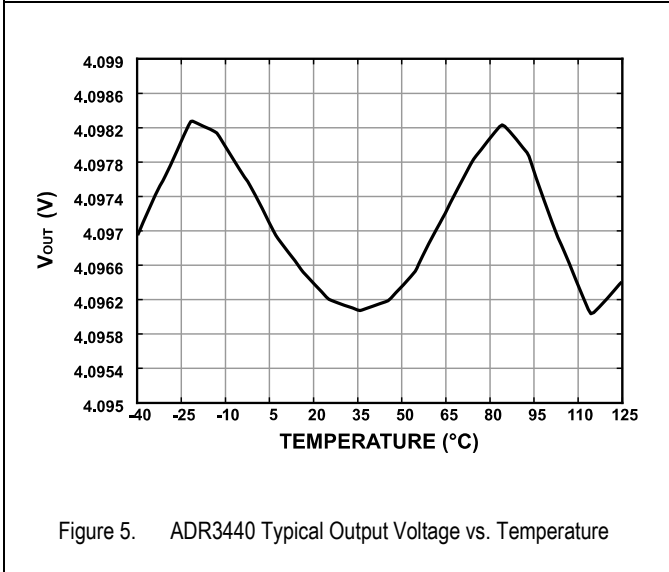
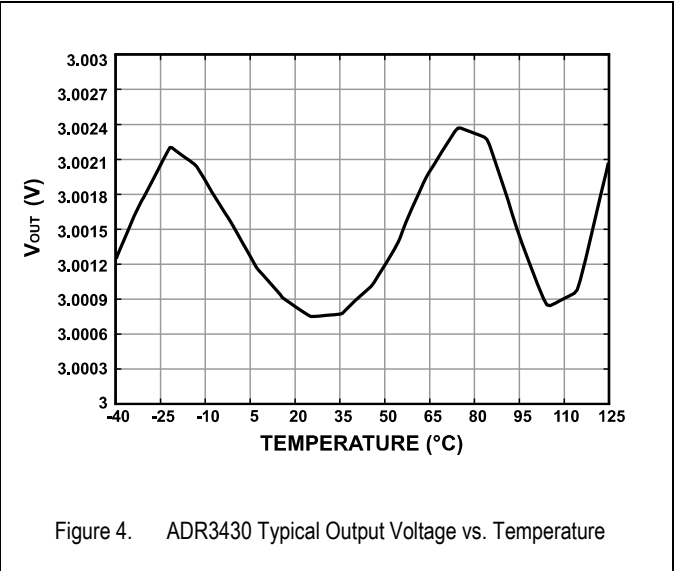
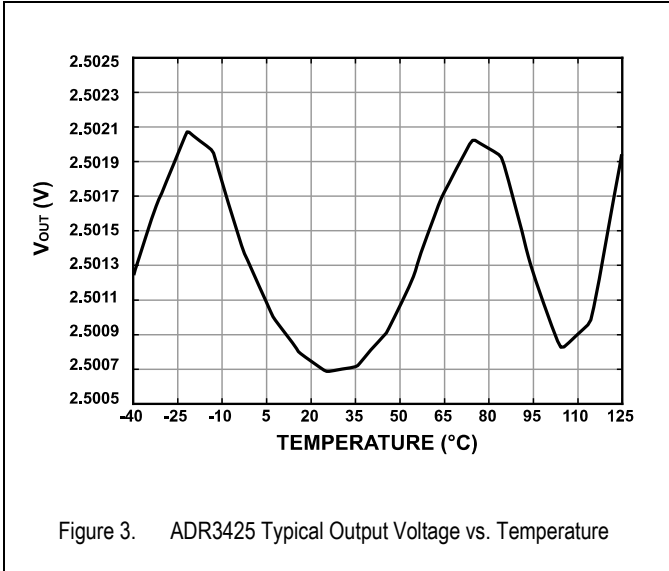

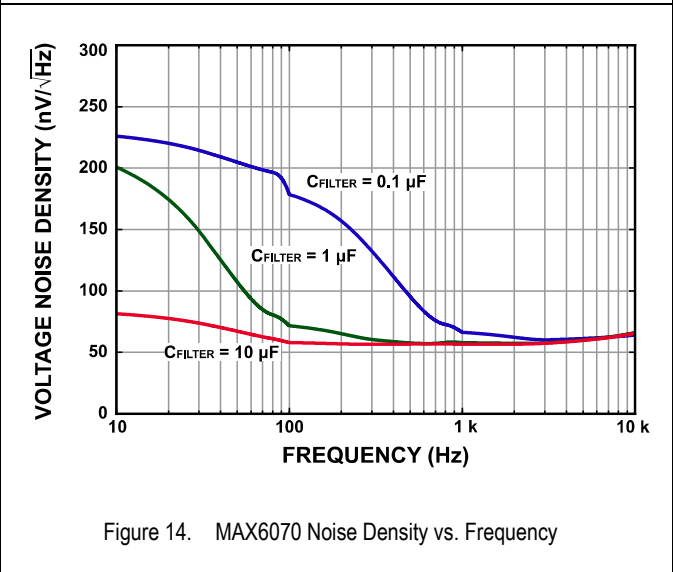
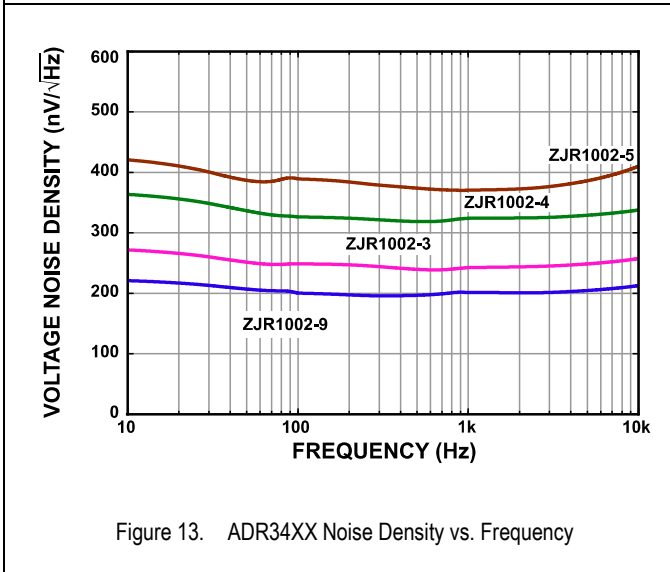
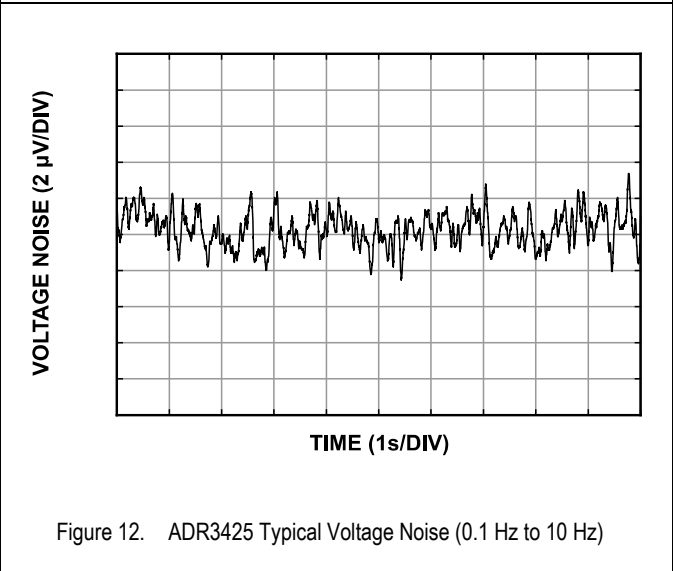
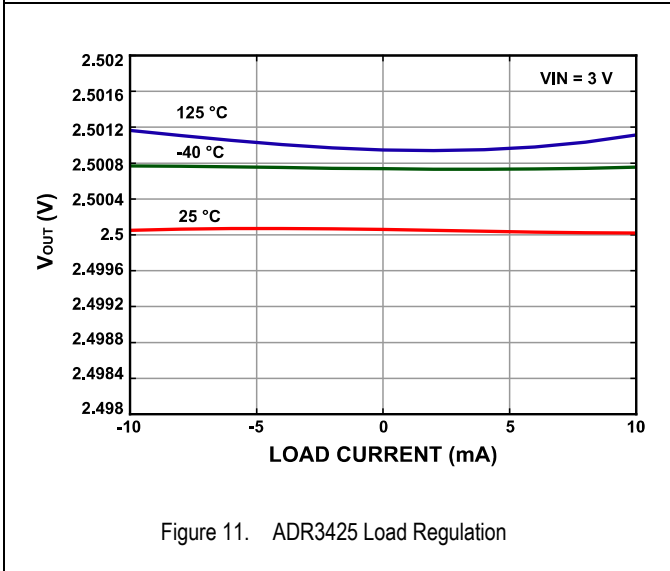
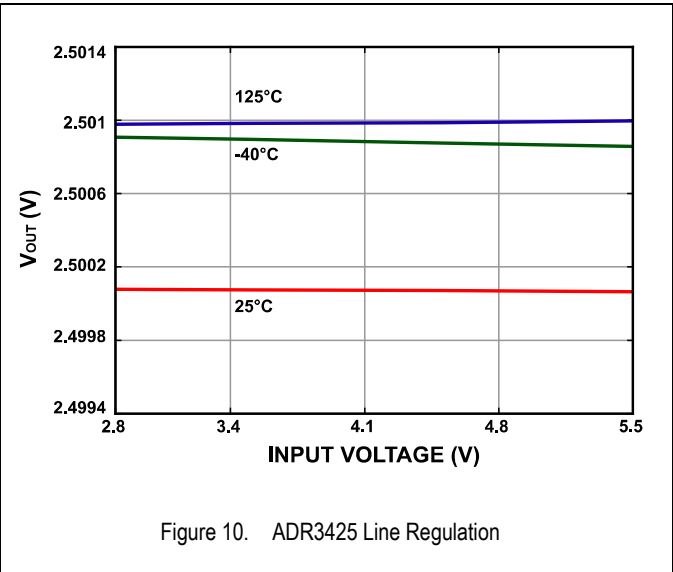
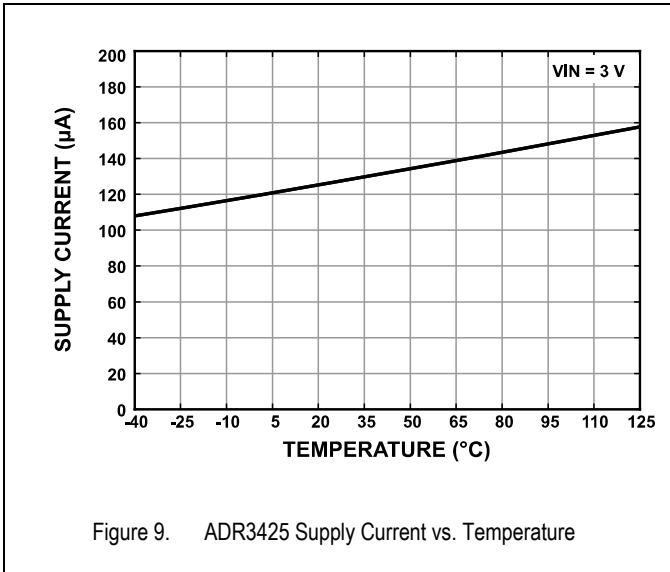

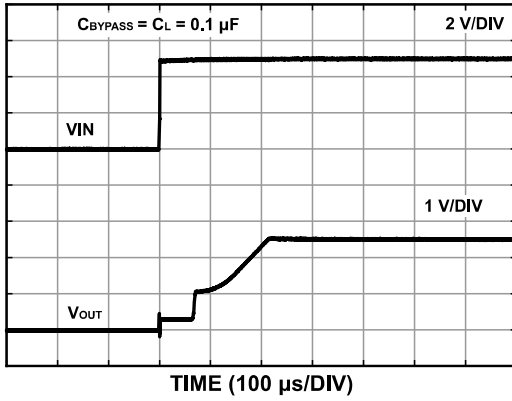

Figure 15. ADR3425 Turn-On Response

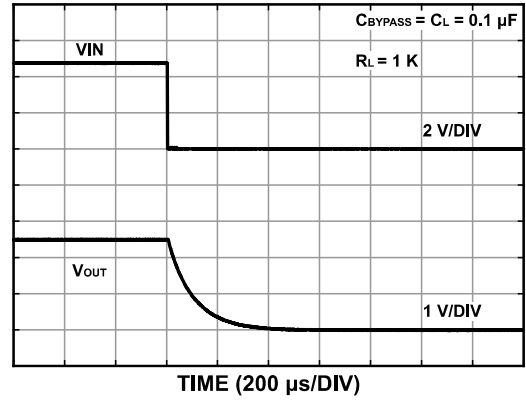

Figure 16. ADR3425 Turn-Off Response

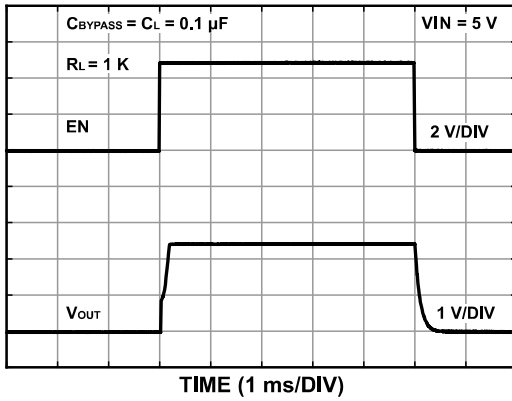

Figure 17. ADR3425 Enable Transient

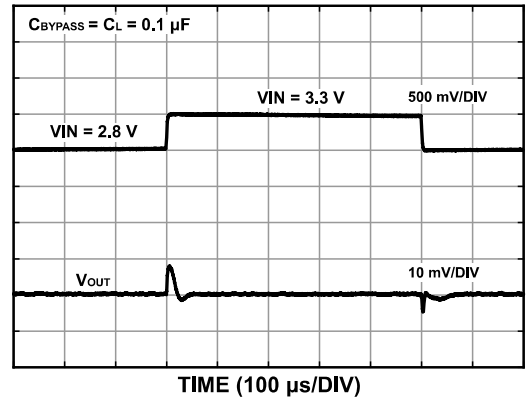

Figure 18. ADR3425 Line Transient

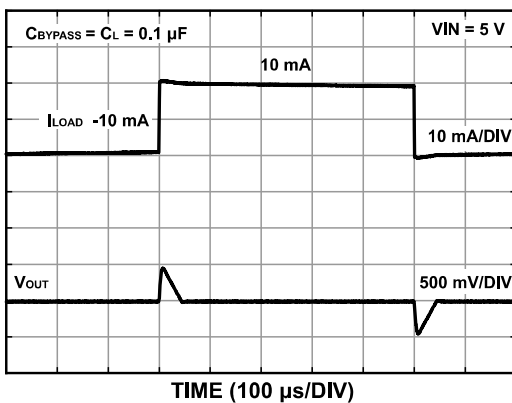

Figure 19. ADR3425 Load Transient

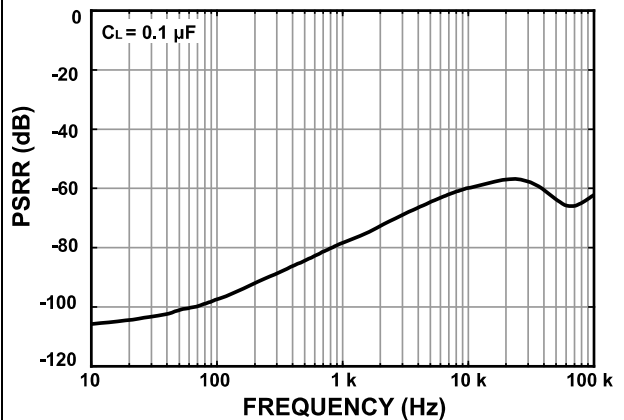
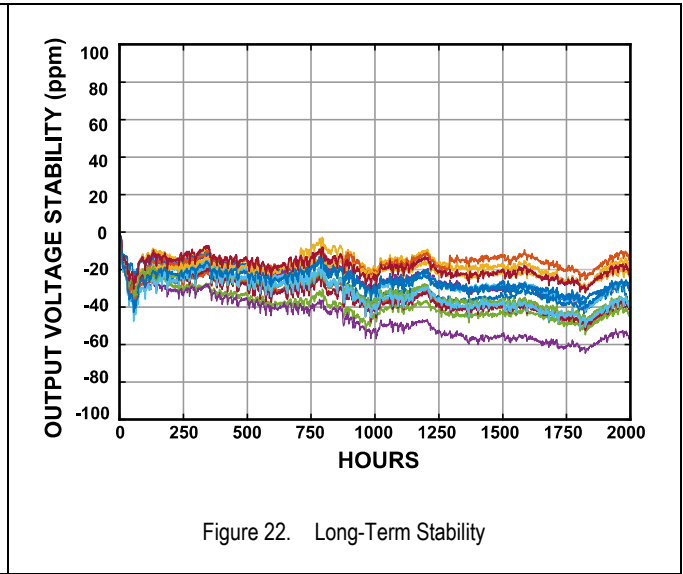
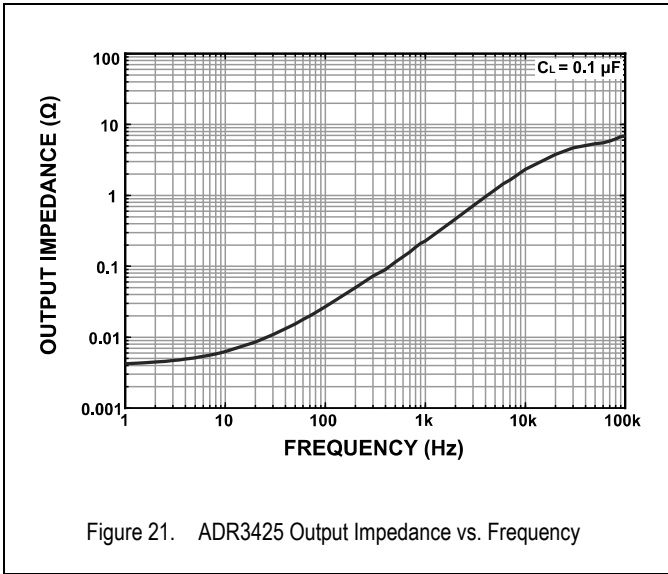

Figure 20. ADR3425 Power Supply Rejection Ratio vs. Frequency



Terminology

Temperature Coefficient

The change of output voltage over the operating temperature range is normalized by the output voltage at 25 °C, and expressed in ppm/°C as

$$dV_{OUT}/dT = \frac{V_{OUT(max)} - V_{OUT(min)}}{V_{OUT(25)} \times (T2 - T1)} \times 10^6$$

Where:

$V_{OUT(25)}$: Output voltage at 25 °C.

$V_{OUT(min)}$: The lowest output voltage over temperature T1 to T2 range.

$V_{OUT(max)}$: The highest output voltage over temperature range T1 to T2.

For ZJW Micro voltage references, temperature T1 is -40 °C, and T2 is +125 °C.

Long-term Stability

This is the measurement of the change in output voltage of the measured device at 25 °C after 1000 hours (approximately 42 days) of operation at a constant ambient temperature. Generally measured in ppm. Long-term stability is not only affected by variations in the device itself, but also by soldering and board materials. Long-term stability generally exhibits a logarithmic characteristic, therefore the change in the second 1000 hours will be much smaller than the change in the first 1000 hours.

$$LTD = \frac{V_{OUT(t0)} - V_{OUT(t1)}}{V_{OUT(t0)}} \times 10^6$$

where:

$V_{OUT(t0)}$: Output voltage at 25 °C at Time 0.

$V_{OUT(t1)}$: Output voltage at 25 °C at Time 1 after 1000 hours of operation under constant ambient temperature.

Thermal Hysteresis

The change of output voltage after the device is cycled through temperatures from +25 °C to -40 °C to +125 °C and back to +25 °C. This is a typical value from a sample of parts put through such a cycle. It is normally in ppm using the following equation:

$$TH = \frac{V_{OUT(25)} - V_{OUT(TC)}}{V_{OUT(25)}} \times 10^6$$

where:

$V_{OUT(25)}$: Output voltage at 25 °C.

$V_{OUT(TC)}$: Output voltage at 25 °C after the temperature cycle.

Line Regulation

The change in output voltage due to a specified change in input voltage. It includes the effects of self-heating. Line regulation is expressed in either percent per volt, parts per million per volt, or microvolts per volt change in input voltage, such as ppm/V.

Load Regulation

The change in output voltage due to a specified change in load current. It includes the effects of self-heating. Load regulation is expressed in either microvolts per milliampere or parts per million per milliampere, such as ppm/mA.

Theory of Operation

MAX6070/ ADR34XX series of precision voltage reference products is based on state-of-the-art CMOS technology, Figure 23 & Figure 24 shows MAX6070 & ADR34XX's internal blocks respectively. The bandgap reference is the core, which has been carefully designed and can deliver the key performances by proprietary post-package trimming. All pins have the internal protection circuit in order to make MAX6070 & ADR34XX reliable parts, and their ESD level reaches 8 kV HBM.

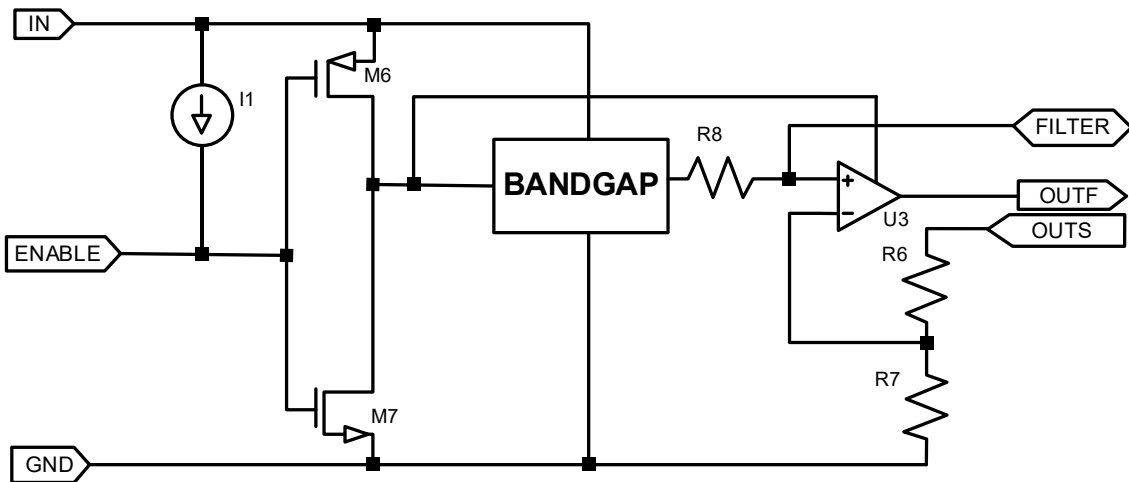

Figure 23. Simplified Schematic of MAX6070

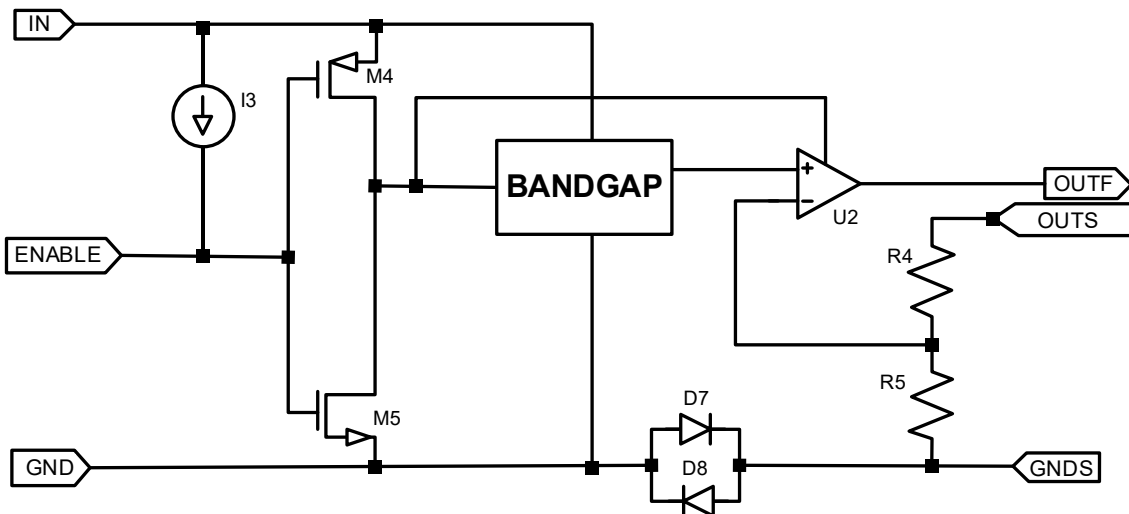

Figure 24. Simplified Schematic of ADR34XX

Applications

MAX6070, ADR34XX Basic Connections

Voltage references, including MAX6070 & ADR34XX, normally require a capacitor at the output between OUTF and GND. Figure 25 is the basic connection of MAX6070/ADR34XX. Other than a 0.1 μF capacitor at the output, no further component is needed for normal operation.

To reduce noise further, an additional capacitor can be connected to the FILTER pin of MAX6070.

However, in actual system, the power supply may change rapidly. Adding a 1 μF to 10 μF capacitor at the input can help the performances of the voltage reference. An additional 0.1 μF capacitor in parallel can reduce power supply noise further.

The output capacitance ranges from 0.1 μF to 10 μF . Too big capacitive load can cause output oscillation. Capacitor equivalent series resistance (ESR) within 1.5 Ω is recommended to ensure its stability. Meanwhile, larger output capacitor results in longer turn-on time.

Capacitance value depends on the load of the voltage reference, source or sink current et al. New SAR ADC.

It is recommended to use surface-mounted ceramic capacitors (such as X5R, X7R). If an electrolytic capacitor is used at the output, a 0.1 μF ceramic capacitor should be placed in parallel to reduce the overall ESR at the output. In addition, the capacitors' operating temperature range should be wider, or at least the same as the system's temperature range.

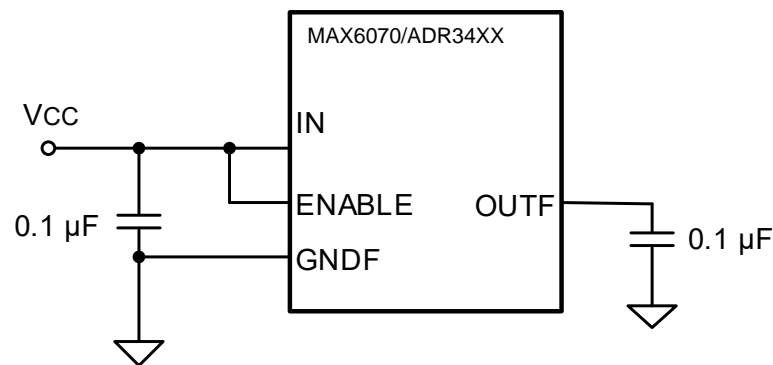

Figure 25. MAX6070/ADR34XX Basic Connections

Power On and Shutdown Mode

Figure 15 shows the turn-on process of ADR34XX and 6070 has the similar turn-on process. The value of the load capacitance affects the turn-on time. In general, the larger the load capacitance, the longer the settling time. Settling to higher accuracy sees exponentially longer turn-on time.

For power sensitive high precision applications, 6070 and ADR34XX have shutdown mode, which has the supply current of 3 μA across the specified temperature range. Drive pin 3 (ENABLE) low, the part will enter shutdown mode & high will be in normal operation as can be found in Figure 17. Leave pin 3 unconnected (there is a weak internal pull-up circuit) or connect to IN, 6070 or ADR34XX will be in normal operation.

Supply Voltage

The supply voltage of MAX6070 and ADR34XX ranges from 300 mV higher than the output voltage to 5.5 V. It is recommended to power MAX6070 & ADR34XX by linear power supplies, such as LDO, in order to get high performances.

Noise Performance

MAX6070 and ADR34XX have very low output noise. The noise of ADR3425 is typically within 2.5 ppm_peak-to-peak over the 0.1 Hz to 10 Hz band. The noise measurement is made with a band-pass filter made of a high-pass filter with a corner frequency at 0.1 Hz and a low-pass filter with a corner frequency at 10 Hz.

Connect an external capacitor to pin 1 of 6070 (FILTER) can further reduce its noise. By adding a 0.1 μ F capacitor, ADR34XX's noise at 1 kHz dropped from 200 nV/\sqrt{Hz} without capacitor to 60 nV/\sqrt{Hz} . If the noise reduction is not needed, leave pin 1 unconnected.

Power Dissipation

MAX6070 and ADR34XX are low power dissipation devices with a typical supply current of 130 μ A. In case of heavy load, it is necessary to calculate the power dissipation of the device, and take in to account the performance changes caused by it. The temperature of the device increases according to the equation below.

$$T_J = P_D \times \theta_{JA} + T_A$$

where:

T_J = Junction temperature ($^{\circ}$ C)

T_A = Ambient temperature ($^{\circ}$ C)

P_D = Power dissipated (W)

θ_{JA} = Junction-to-ambient thermal resistance ($^{\circ}$ C/W)

The junction temperature of MAX6070 and ADR34XX must not exceed the absolute maximum rating of 150 $^{\circ}$ C.

Product Applications

Voltage Reference Noise to ADC Resolution

In general, the voltage reference's 0.1 Hz to 10 Hz noise should be within ADC's 1/2 LSB. With the same resolution, the larger the full-scale voltage, the lower the noise requirement to the voltage reference as can be found in Table 1. MAX6070 and ADR34XX are able to be used as 16-bit ADC voltage reference.

Resolution(bit)	0.1 Hz to 10 Hz Noise ($\mu\text{V}_{\text{P-P}}$)	
	2.5 V full scale	5 V full scale
8	4,882.8	9,765.6
10	1,220.7	2,441.4
12	305.2	610.4
14	76.3	152.6
16	19.1	38.1
18	4.8	9.5

Table 1. ADC Resolution vs. Voltage Reference Noise

Using ADR34XX and ADC91001 to Build up to 18-bit Signal Sources

It is a great challenge to generate a programmable high-precision signal source with more than 16-bit accuracy. The high-performance voltage reference is required to ensure the noise and temperature performances of both voltage and current output signals. Also, for some systems, the performances over time (also known as time drift) are required. Based on TOKMAS complete high-performance signal chain products, the reference design is developed as shown in Figure 26. It can achieve up to 18-bit accuracy if ADC91001 will be used together with ADR34XX. The Kelvin connection of ADR34XX and the Kelvin connection requirement of 18-bit precision digital-to-analog converter (DAC) ADC91001 matches well to improve the system's resistance to load changes and easy implementation.

ADR34XX's low noise and temperature drift within 5 ppm/°C are critical to ensure the performance of the whole design.

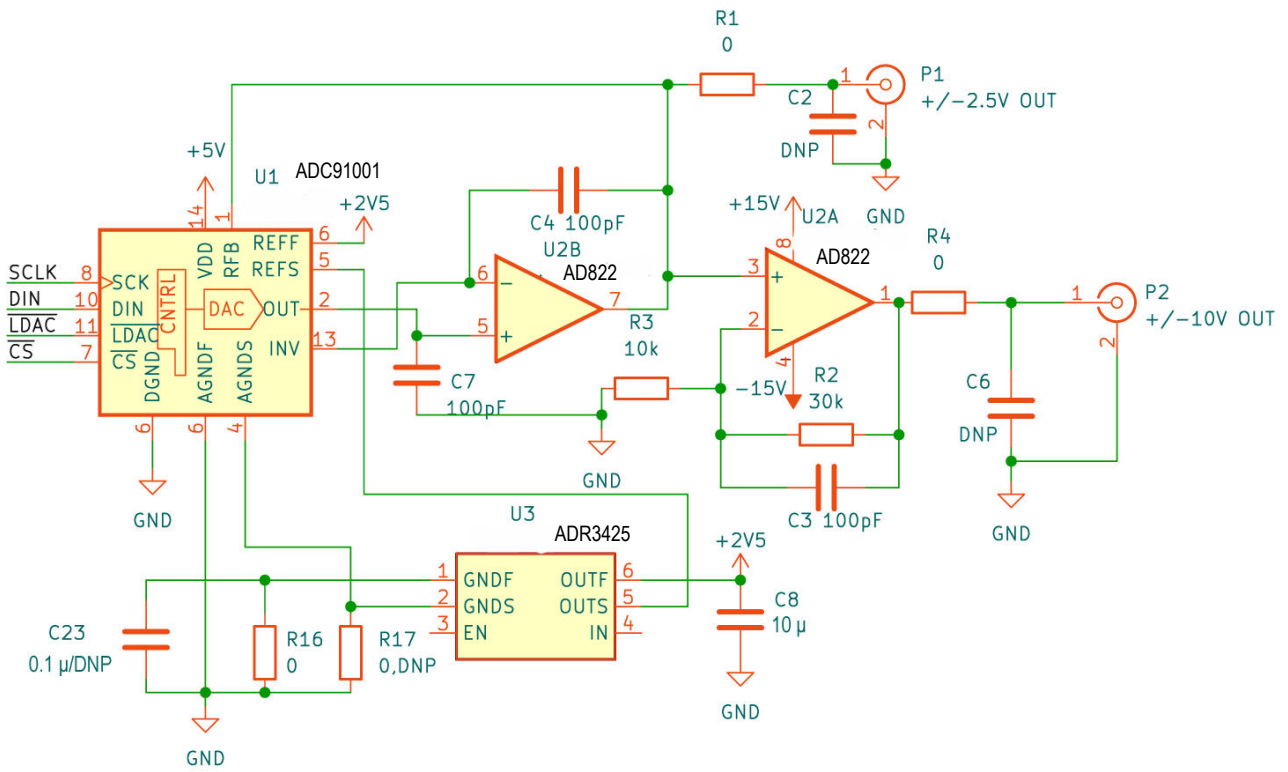

Figure 26. ADR34XX and ADC91001 build 18-bit programmable signal source

Layout Guidelines

- Place the power-supply bypass capacitor as closely as possible to the supply and ground pins. The recommended value of this bypass capacitor is from 1 μF to 10 μF . If necessary, additional decoupling capacitance can be added to compensate for noisy or high-impedance power supplies.
- The output must be decoupled with a bigger than 0.1 μF capacitor. For better noise performance, the recommended ESR on the output capacitor is from 1 Ω to 1.5 Ω . For even lower noise, a larger capacitor in parallel or an RC filter can be added.
- Use large area ground plane if possible. Keep fast-changing or high-frequency interference signals far from MAX6070 or ADR34XX.

Layout Example

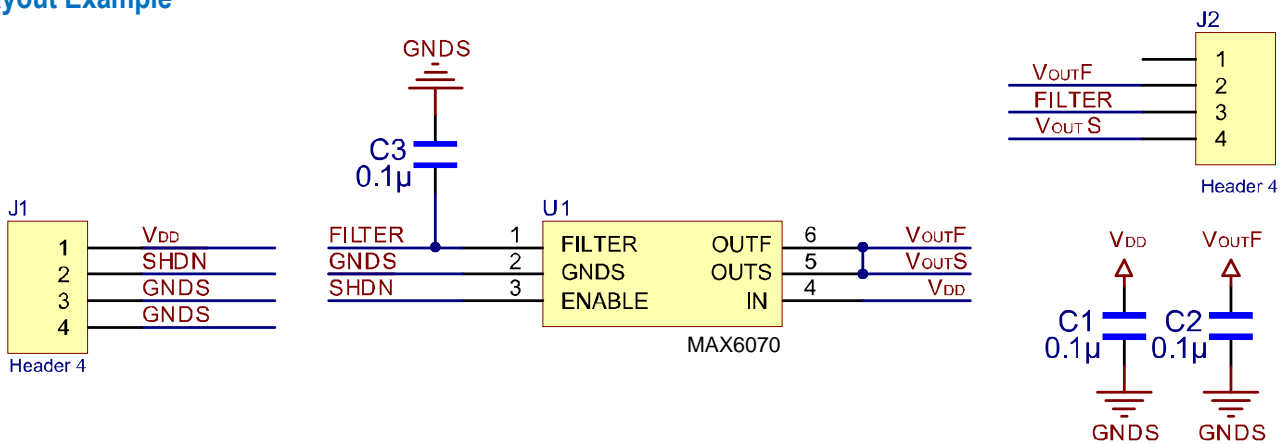

Figure 27. 6070XX Evaluation Board Schematic

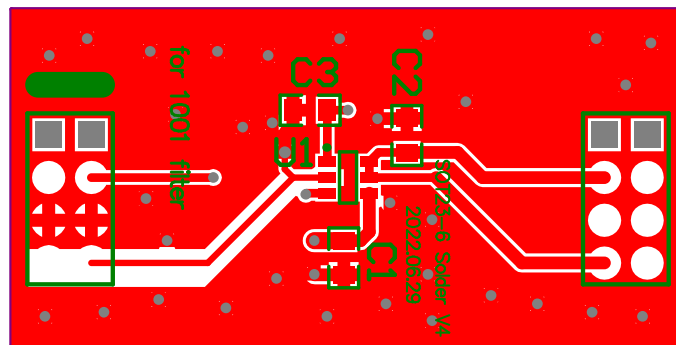

Figure 28. 6070XX Evaluation Board Layout (Top Layer)

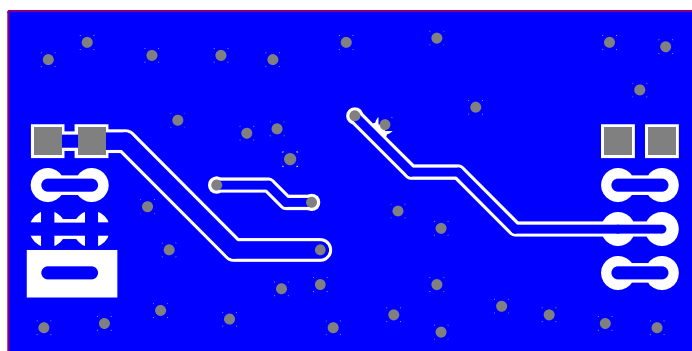

Figure 29. 6070XX Evaluation Board Layout (Bottom Layer)

Outline Dimensions

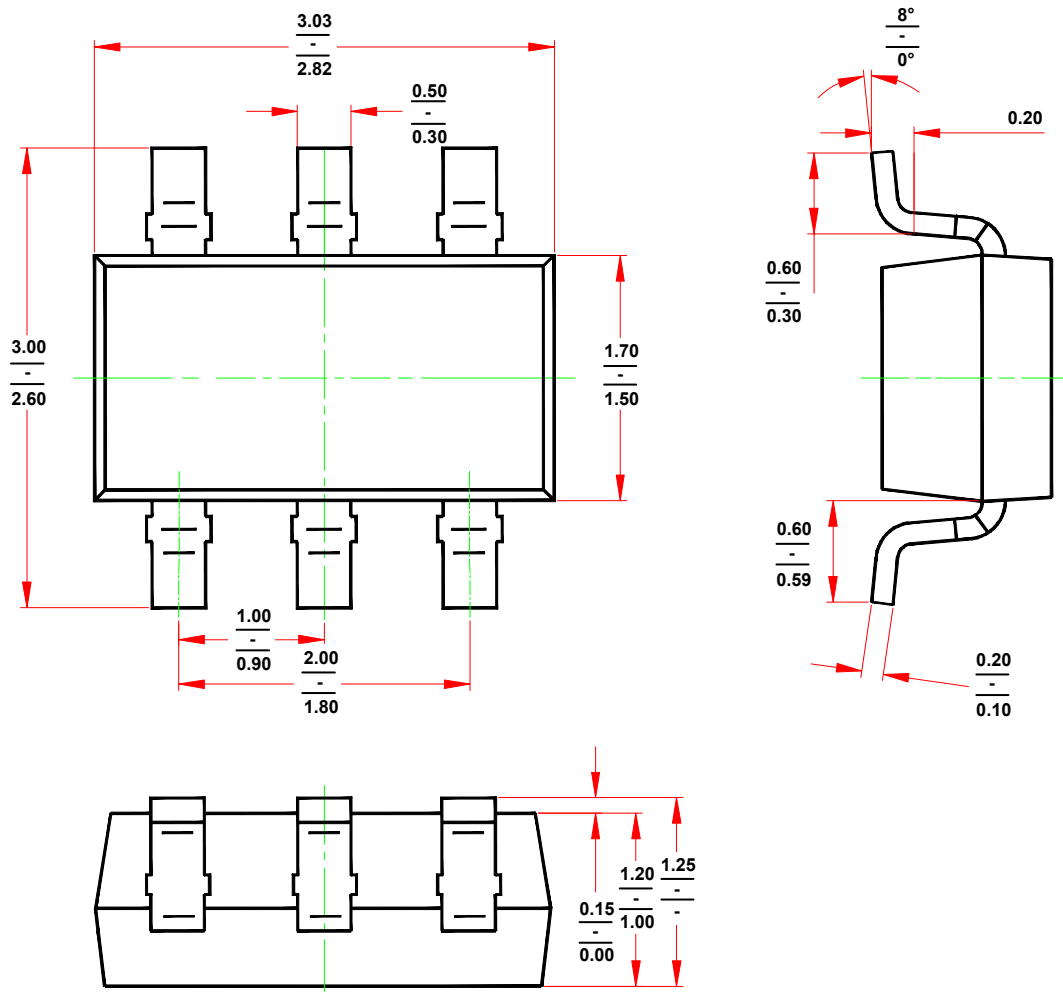

Figure 30. 6-Lead SOT23 Package Dimensions shown in millimeters

Ordering Guide

Model	Orderable Device	Output Voltage (V)	Max Temp Co (ppm/°C)	Mark	Package	External Package
MAX6070	MAX6070BAUT25	2.5	5	1001-9	SOT23-6	7" reel
	MAX6070BAUT25T		8			
MAX6070	MAX6070BAUT30	3	5	1001-3		
	MAX6070BAUT30T		8			
MAX6070	MAX6070BAUT40	4.096	5	1001-4		
	MAX6070BAUT40T		8			
MAX6070	MAX6070BAUT50	5	5	1001-5		
	MAX6070BAUT50T		8			
ADR3420	ADR3420ARJZ-R7	2.048	5	1002-2		
	ADR3420ARJZ-R2		8			
ADR3425	ADR3425ARJZ-R7	2.5	5	1002-9		
	ADR3425ARJZ-R2		8			
ADR3430	ADR3430ARJZ-R7	3	5	1002-3		
	ADR3430ARJZ-R2		8			
	ADR3430ARJZ-7RQ		5	1002Q3		
	ADR3430ARJZ-2RQ		8			
ADR3433	ADR3433ARJZ-R7	3.3	5	1002-8		
	ADR3433ARJZ-R2		8			
ADR3440	ADR3440ARJZ-R7	4.096	5	1002-4		
	ADR3440ARJZ-R2		8			
ADR3450	ADR3450ARJZ-R7	5	5	1002-5		
	ADR3450ARJZ-R2		8			