

## 1. Description

The UMW ST3485E is a 3.3V powered, half-duplex, low-power RS-485 transceiver that fully meets the requirements of the TIA/EIA-485 standard. The UMW ST3485E includes a driver and a receiver, both of which can be independently enabled and disabled. When both are disabled, both the driver and the receiver output a high impedance state. The UMW ST3485E has a 1/8 load that allows 256 ST3485E transceivers to be connected to the same communication bus. Error-free data transfer of up to 12 Mbps is possible. The UMW ST3485E operates from a voltage range of 3.0 to 3.6V and features fail-safe, over temperature protection, current limit protection, over-voltage protection, and other functions.

## 3. Pinning information

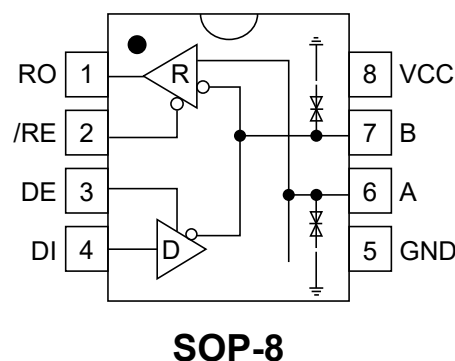

## 2. Features

- 3.3V power supply, half-duplex
- 1/8 unit load allows up to 256 devices on the bus
- Driver output short-circuit protection function
- Over temperature protection function
- Low power shutdown function
- Receiver open circuit protection function
- Strong anti-noise ability
- Integrated transient voltage resistance function
- Transmission rate up to 12Mbps in an electrical noise environment;



## 4.Pin Functions

Pin number	Pin name	Pin function
1	RO	Receiver output When /RE is low level: if A-B $\geq$ 200mV, RO=high; if A-B $\leq$ -200mV, RO=low
2	/RE	Receiver output enable control When /RE is low level, receiver output is enabled, and RO output is available. When /RE is high level, receiver output is disabled, and RO is in high impedance state. When /RE is high level and DE is low level, the device enters low power consumption mode.
3	DE	Driver output enable control When DE is high level, driver output is available; when DE is low level, the output is in high impedance state. When /RE is high level and DE is low level, the device enters low power consumption mode.
4	DI	Driver input When DE is high level, the DI low level forces the non-inverting driver output A low and inverting driver output B high; The DI high level forces the non-inverting driver output A high and inverting driver output B low.
5	GND	Ground
6	A	Non-inverting receiver input and non-inverting driver output
7	B	Inverting receiver input and inverting driver output
8	VCC	Power supply



## 5.Limiting Values

Parameter	Symbol	Value	Units
Supply voltage	$V_{CC}$	7	V
Voltage of control port	/RE, DE, DI	-0.3 to 7	V
Bus side input voltage	A, B	-7 to 13	V
Receiver output voltage	RO	-0.3 to ( $V_{CC}+0.3$ )	V
Operating temperature range		-40 to 105	°C
Storage temperature range		-60 to 150	°C
Welding temperature		300	°C
Continuous power dissipation	SOP-8	400	mW

The maximum limit parameter value means that exceeding these values may cause irreversible damage to the device. Under these conditions, it is not conducive to the normal operation of the device. Continuous operation of the device under the maximum allowable rating may affect the reliability of the device. The reference point of all voltages is ground.



## 6.Driver Electrical Characteristics

Parameter	Symbol	Conditions	Min	Typ	Max	Units
Differential output voltage (no load)	$V_{OD1}$			3.3		V
Differential output voltage	$V_{OD2}$	Figure 2, $R_L=54\Omega$	1.5		$V_{CC}$	V
		Figure 2, $R_L=100\Omega$	2		$V_{CC}$	V
Change in magnitude of differential output voltage (NOTE1)	$\Delta V_{OD}$	Figure 2, $R_L=54\Omega$			0.2	V
Common mode output voltage	$V_{OC}$	Figure 2, $R_L=54\Omega$			3	V
Change in magnitude of common mode output voltage (NOTE1)	$\Delta V_{OC}$	Figure 2, $R_L=54\Omega$			0.2	V
Input high voltage	$V_{IH}$	DE, DI, /RE	2			V
Input low voltage	$V_{IL}$	DE, DI, /RE			0.8	V
Logic input current	$I_{IN1}$	DE, DI, /RE	-2		2	$\mu A$
Output short-circuit current,short-circuit to high	$I_{OSD1}$	Short-circuit to 0V~12V			250	mA
Output short-circuit current,short-circuit to low	$I_{OSD2}$	Short-circuit to -7V~0V	-250			mA
Thermal shutdown threshold				140		$^{\circ}C$
Thermal shutdown hysteresis				20		$^{\circ}C$

(unless otherwise stated  $V_{CC}=3.3V\pm 10\%$ ,  $Temp=T_{MIN}\sim T_{MAX}$ , typical value is  $V_{CC}=+3.3V$ ,  $T_{emp}=25^{\circ}C$ )

NOTE1:  $\Delta V_{OD}$  and  $\Delta V_{OC}$  are the changes in  $V_{OD}$  and  $V_{OC}$  amplitude caused by a change of DI state of the input signal.



## 7.Receiver Electrical Characteristics

Parameter	Symbol	Conditions	Min	Typ	Max	Units
Input current (A, B)	$I_{IN2}$	DE=0V, $V_{CC}=0$ or 3.3V, $V_{IN}=12V$			125	$\mu A$
		DE=0V, $V_{CC}=0$ or 3.3V, $V_{IN}=-7V$	-100			$\mu A$
Positive-going input threshold voltage	$V_{IT+}$	$-7V \leq V_{CM} \leq 12V$			200	mV
Negative-going input threshold voltage	$V_{IT-}$	$-7V \leq V_{CM} \leq 12V$	-200			mV
Hysteresis voltage	$V_{hys}$	$-7V \leq V_{CM} \leq 12V$	10	30		mV
High level output voltage	$V_{OH}$	$I_{OUT}=-2.5mA$ , $V_{ID}=200$ mV	$V_{CC}-1.5$			V
Low level output voltage	$V_{OL}$	$I_{OUT}=2.5mA$ , $V_{ID}=-200$ mV			0.4	V
Tristate leakage current	$I_{OZR}$	$0.4V < V_O < 2.4V$			$\pm 1$	$\mu A$
Receiver input resistance	$R_{IN}$	$-7V \leq V_{CM} \leq 12V$	96			k $\Omega$
Receiver short-circuit current	$I_{OSR}$	$0V \leq V_O \leq V_{CC}$	$\pm 8$		$\pm 60$	mA

(unless otherwise stated  $V_{CC}=3.3V \pm 10\%$ ,  $Temp=T_{MIN} \sim T_{MAX}$ , typical value is  $V_{CC}=+3.3V$ ,  $Temp=25^{\circ}C$ )

## 8.Supply Current

Parameter	Symbol	Conditions	Min	Typ	Max	Units
Supply current	$I_{CC1}$	/RE=0V, DE=0V		520	800	$\mu A$
	$I_{CC2}$	/RE= $V_{CC}$ , DE= $V_{CC}$		540	700	$\mu A$



## 9.Driver Switching Characteristics

Parameter	Symbol	Conditions	Min	Typ	Max	Units
Driver differentialoutput delay	$t_{DD}$	$R_{DIFF}=60\Omega$ , $C_{L1}=C_{L2}=100pF$		10	35	ns
Driver differentialoutput transition time	$t_{TD}$	(see Figure 3 and Figure 4)		12	25	ns
Driver propagationdelay, low-to-high	$t_{PLH}$	$R_{DIFF}=27\Omega$		8	35	ns
Driver propagationdelay, high-to-low	$t_{PHL}$	(see Figure 3 and Figure 4)		8	35	ns
$ t_{PLH} - t_{PHL} $	$t_{PDS}$			1	8	ns
Driver enable to output high	$t_{PZH}$	$R_L=110\Omega$ , (see Figure 5, 6)		20	90	ns
Driver enable to output low	$t_{PZL}$			20	90	ns
Driver disable time from low	$t_{PLZ}$			20	80	ns
Driver disable time from high	$t_{PHZ}$			20	80	ns
Driver enable from shutdownto output high	$t_{DSH}$			500	900	ns
Driver enable from shutdownto output low	$t_{DSL}$			500	900	ns



## 10.Receiver Switching Characteristics

Parameter	Symbol	Conditions	Min	Typ	Max	Units
Receiver input to output delay (low to high)	$t_{RPLH}$	$C_L=15pF$ See Figure 7 and Figure 8		80	150	ns
Receiver input to output delay (high to low)	$t_{RPHL}$			80	150	ns
$ t_{RPLH} - t_{RPHL} $	$t_{RPDS}$			7	10	ns
Receiver enable to output low	$t_{RPZL}$	$C_L=15pF$ See Figure 7 and Figure 8		20	50	ns
Receiver enable to output high	$f_{RPZH}$			20	50	ns
Receiver disable time from low	$t_{PRLZ}$			20	45	ns
Receiver disable time from high	$f_{PRHZ}$			20	45	ns
Receiver enable from shutdown to output high	$f_{RPSH}$			200	1400	ns
Receiver enable from shutdown to output low	$t_{RPSL}$			200	1400	ns
Time to shutdown	$t_{SHDN}$		NOTE2	80		300

NOTE2: The device is put into shutdown by bringing RE high and DE low. If the enable inputs are in this state for less than 80ns, the device is guaranteed not to enter shutdown. If the enable inputs are in this state for at least 300ns, the device is guaranteed to have entered shutdown.



3.3V power supply, up to 256 nodes, 12Mbps half-duplex, RS485/RS422 transceiver

## 11.Function Table

### Driver

Control		Input	Output	
/RE	DE	DI	A	B
X	1	1	H	L
X	1	0	L	H
0	0	X	Z	Z
1	0	X	Z (shutdown)	
X: don't care; Z: high impedance				

### Receiver

Control		Input	Output
/RE	DE	A-B	RO
0	X	$\geq 200\text{mV}$	H
0	X	$\leq -200\text{mV}$	L
0	X	Open/short-circuit	H
1	X	X	Z
X: don't care; Z: high impedance			



## 12. Test Circuit

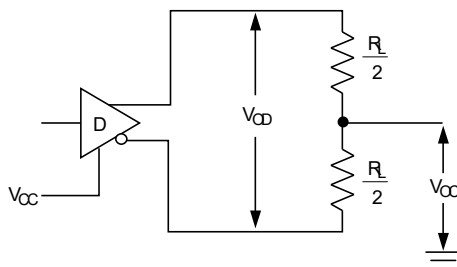

Figure 2. Driver DC test load

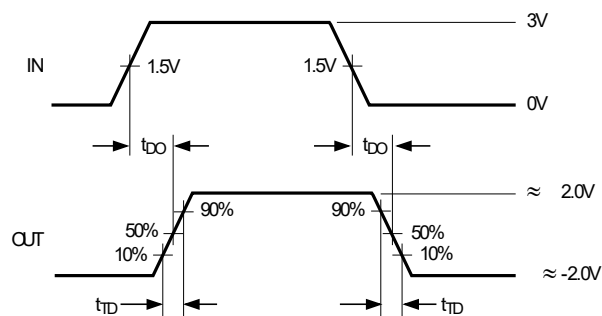
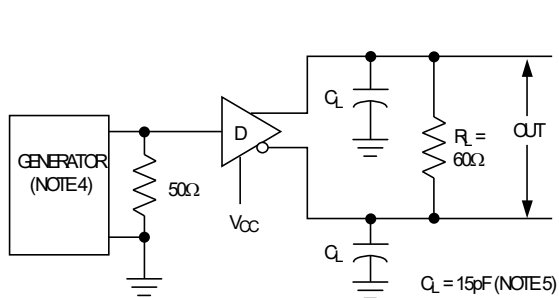

Figure 3. Driver Differential Output Delay and Transition Times

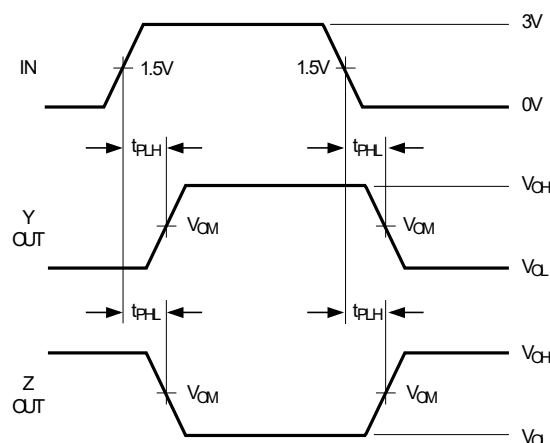
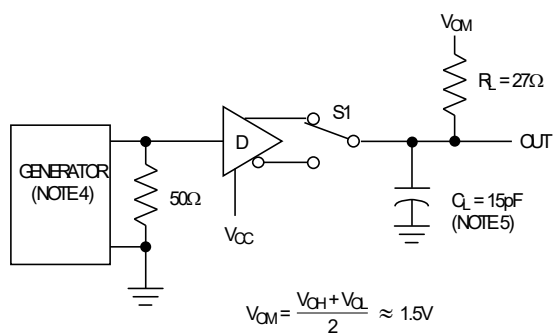

Figure 4. Driver Propagation Times

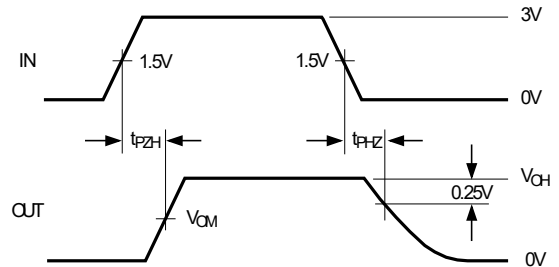
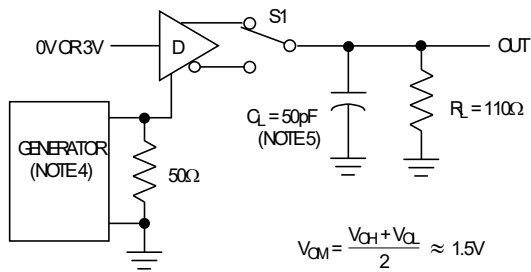

Figure 5. Driver enable and disable times

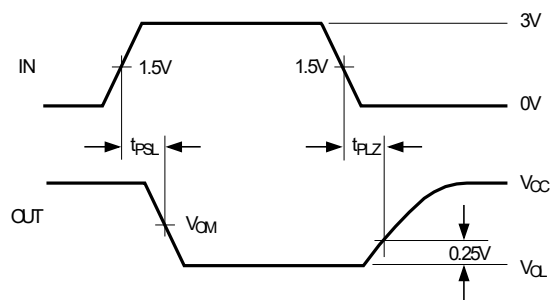
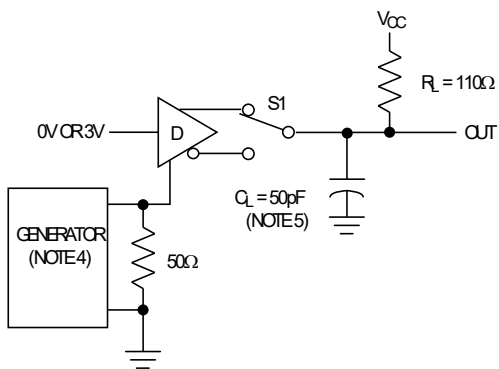

Figure 6. Driver enable and disable times

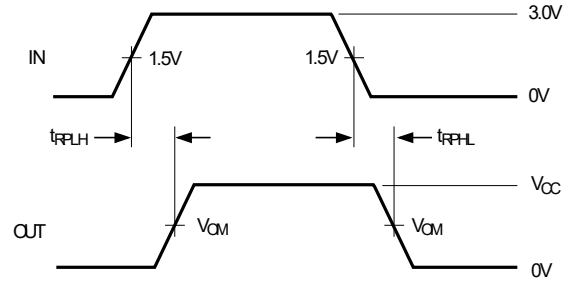
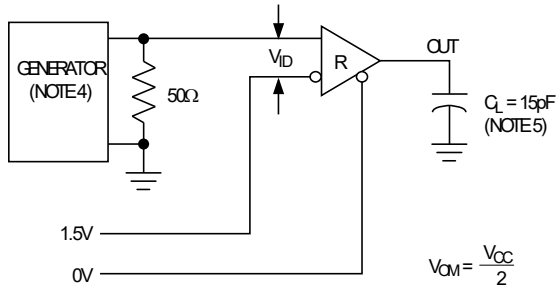

Figure 7. Receiver Propagation Delay

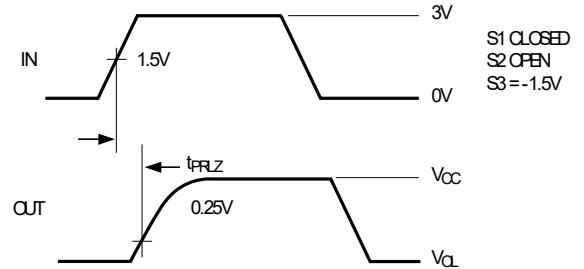
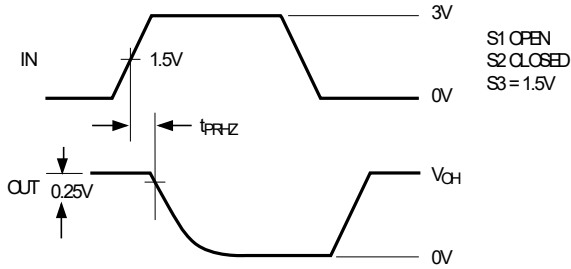
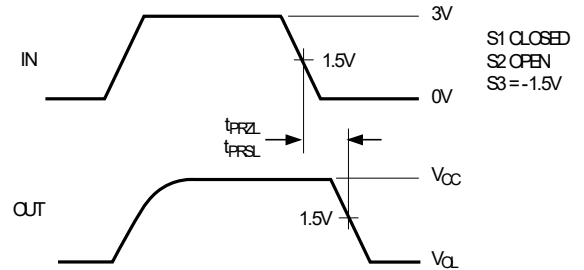
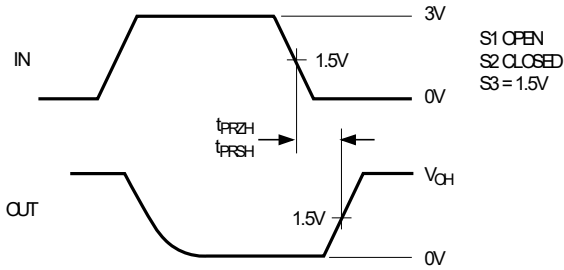
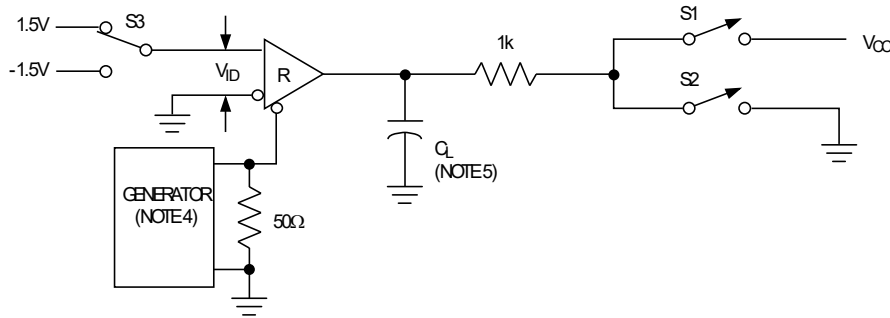

Figure 8. Receiver Enable and Disable Times



## 13. General Description

### 1 Brief description

The UMW ST3485EBDR is a half-duplex high-speed transceiver for RS-485/RS-422 communication, and includes one driver and one receiver. It has fail-safe, over-voltage protection and over-current protection. The MAX3485E allows error-free data transmission up to 12Mbps.

### 2 Allowing up to 256 transceivers on the bus

The standard RS-485 receiver has an input impedance of 12k $\Omega$  (1 unit load), and the standard driver can drive up to 32 unit loads. The receiver of the UMW ST3485EBDR transceiver has a 1/8 unit load receiver input impedance (96k $\Omega$ ), allowing up to 256 transceivers to be connected in parallel on one bus. These devices can be combined arbitrarily, or combined with other RS-485 transceivers, as long as the total load does not exceed 32 units.

### 3 Driver output protection

Two mechanisms are used to avoid faults or bus collisions that cause excessive output current and excessive power consumption. First, over-current protection provides fast short-circuit protection over the entire common-mode voltage range (refer to the typical operating characteristics). Second, the thermal shutdown circuit forces the driver output into a high impedance state when the die temperature exceeds 140°C.

### 4 Typical applications

4.1 Bus networking: The MAX3485E RS485 transceiver is designed for bidirectional data communication on multi-point bus transmission lines. Figure 9 shows a typical network application circuit. These devices can also be used as linear repeaters with cables longer than 4000 feet. In order to reduce reflections, terminal matching should be done at both ends of the transmission line with their characteristic impedance, and the length of the branch wires other than the main line should be as short as possible.



3.3V power supply, up to 256 nodes, 12Mbps half-duplex, RS485/RS422 transceiver

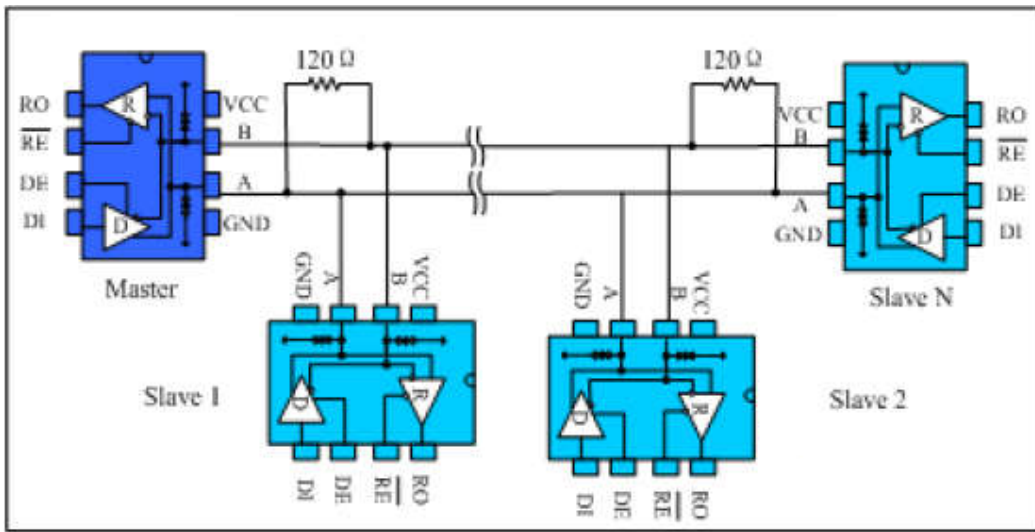

Figure 9. Bus-type RS485 half-duplex communication network

### 4.2 Hand-in-hand networking:

Also known as daisy chain topology, it is the standard and specification of RS485 bus wiring, and is the RS485 bus topology recommended by organizations such as TIA. The wiring method is that the master control device and multiple slave devices form a hand-in-hand connection, as shown in Figure 10, the hand-in hand way is to leave no branches. This wiring method has the advantages of low signal reflection and high communication success rate.

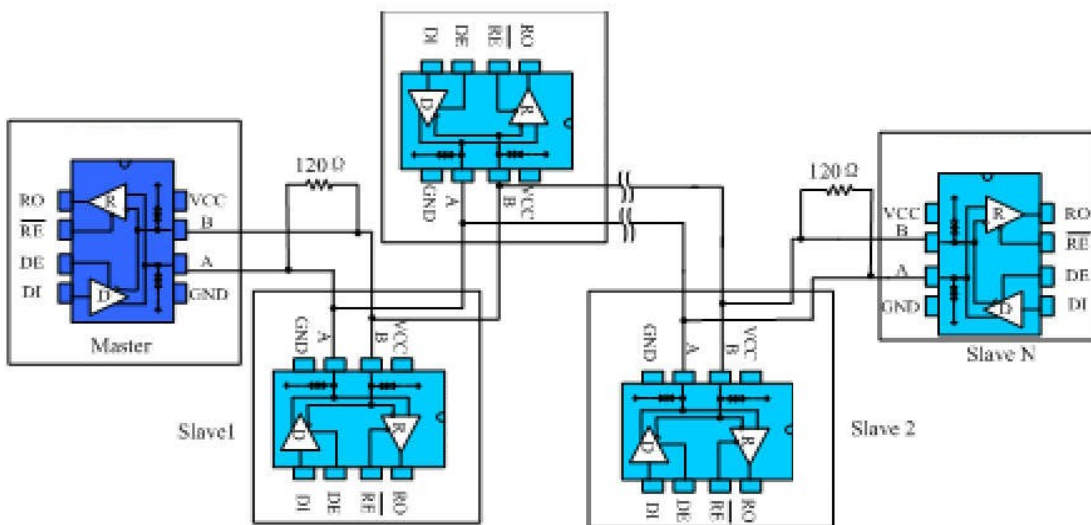

Figure 10. Hand-in-hand type RS485 half-duplex communication network



3.3V power supply, up to 256 nodes, 12Mbps half-duplex, RS485/RS422 transceiver

### 4.3 Bus port protection:

In harsh environments, RS485 communication ports are usually protected against static electricity, lightning and surge protection, etc. and it is even necessary to prevent 380V power supply access to avoid damage of smart meters and industrial control hosts. Figure 11 shows 3 common kinds of RS485 bus port protection schemes. The first scheme is to connect the TVS device to the protection ground in parallel with the AB port, the TVS device in parallel with the AB port, the thermistor in series with the AB port and the gas discharge tube is connected to the protection ground to form a three-level protection scheme. The second scheme is a three-level protection scheme including TVS connected to the ground in parallel with AB, the thermistor in series and the varistor in parallel with AB. The third one includes pull-down resistors connected to the power supply and ground respectively for AB, TVS between AB and the thermistor connected to A or B port.

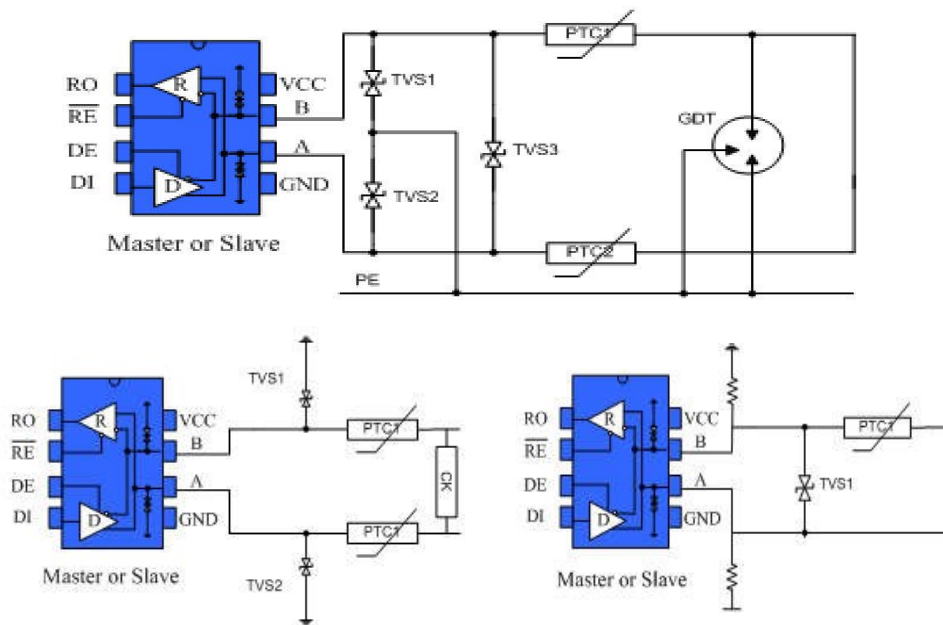
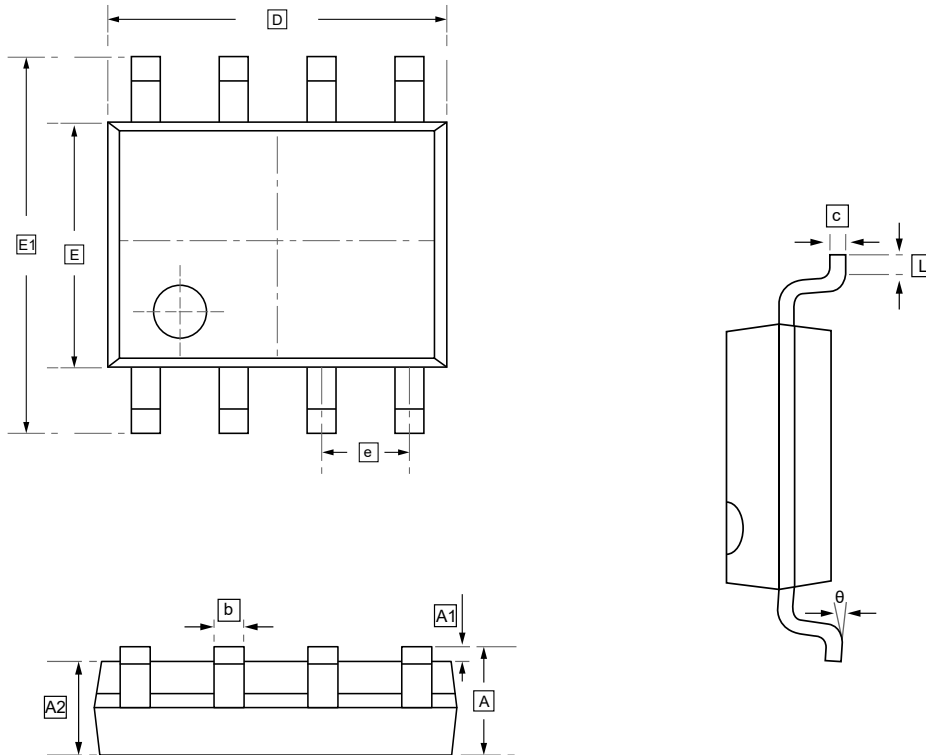

Figure 11. Port protection scheme



## 14.SOP-8 Package Outline Dimensions



### DIMENSIONS (mm are the original dimensions)

Symbol	A	A1	A2	b	c	D	E	E1	e	L	$\theta$
Min	1.350	0.000	1.350	0.330	0.170	4.700	3.800	5.800	1.270	0.400	0°
Max	1.750	0.100	1.550	0.510	0.250	5.100	4.000	6.200	BSC	1.270	8°



3.3V power supply, up to 256 nodes, 12Mbps half-duplex,  
RS485/RS422 transceiver

## 15. Ordering information

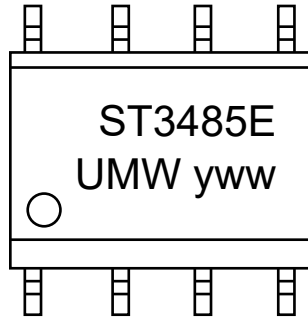

yww: Batch Code

Order Code	Package	Base QTY	Delivery Mode
UMW ST3485EBDR	SOP-8	2500	Tape and reel



## 16.Disclaimer

UMW reserves the right to make changes to all products, specifications. Customers should obtain the latest version of product documentation and verify the completeness and currency of the information before placing an order.

When applying our products, please do not exceed the maximum rated values, as this may affect the reliability of the entire system. Under certain conditions, any semiconductor product may experience faults or failures. Buyers are responsible for adhering to safety standards and implementing safety measures during system design, prototyping, and manufacturing when using our products to prevent potential failure risks that could lead to personal injury or property damage.

Unless explicitly stated in writing, UMW products are not intended for use in medical, life-saving, or life-sustaining applications, nor for any other applications where product failure could result in personal injury or death. If customers use or sell the product for such applications without explicit authorization, they assume all associated risks.

When reselling, applying, or exporting, please comply with export control laws and regulations of China, the United States, the United Kingdom, the European Union, and other relevant countries, regions, and international organizations.

This document and any actions by UMW do not grant any intellectual property rights, whether express or implied, by estoppel or otherwise. The product names and marks mentioned herein may be trademarks of their respective owners.