



E150-400TxxS User Manual

400M frequency band LoRa wireless acquisition control module



contents

Chapter 1 Product Overview	3
1.1 Product introduction	3
1.2 Features	3
1.3 Application scenarios	4
Chapter 2 Specifications	5
2.1 Limit parameters	5
2.2 Working parameters	5
Chapter 3 Mechanical Dimensions and Pin Definition	8
Chapter 4 Recommended Wiring Diagram	12
Chapter 5 Introduction to Modbus RTU Commands	14
5.1 Read coil status	14
5.2 Control coil status	14
5.3 Read input register status	15
5.4 Read hold register	16
5.5 Operation holding register	17
5.6 Broadcast address	18
5.7 Listening address	18
5.8 Module reset	18
5.9 Aux details	18
5.9.1 Serial port data output indication	18
5.9.2 Work instructions	19
5.9.3 Module is in the process of configuration	19
5.9.4 Flash write	20
5.9.5 Complete process of reading IO status of other devices	20
5.9.6 Lora sends data continuously	21
5.9.7 Aux precautions	21
Chapter 6 working mode	22
6.1 UART sleep wake	22
6.2 Mode switching	23
6.3 Normal mode (mode 0)	23
6.4 WOR Mode (Mode 1)	24
6.5 Sleep Mode (Mode 2)	24
6.6 pin status	24
Chapter 7 MODBUS Address Table	26
Chapter 8 module control	29
8.1 digital input (DI)	29
8.2 digital output (DO)	29
8.3 Analog Input (AI)	30
8.4 analog output (AO)	32
8.5 pulse width modulation (PWM)	33
8.6 RS485 pin	34
8.7 about floating point conversion	34
8.8 module use	35

8.9 interaction between modules	35
8.10 about flash operation	36
Chapter 9 introduction to upper computer	37
Chapter 10 hardware design	39
Chapter 11 common problems	40
11.1 the transmission distance is not ideal	40
11.2 module is easy to be damaged	40
11.3 bit error rate is too high	40
Chapter 12 welding operation instructions	41
12.1 Reflow temperature	41
12.2 Reflow soldering curve	42
Chapter 13 relevant models	43
Chapter 14 antenna guide	43
Chapter 15 batch packaging method	45
Revision history	45
About us	46

Chapter 1 Product Overview

1.1 Product introduction

E150-400TXXS is a wireless serial port module (UART) based on LoRa RF chip, operating in the frequency range of 410.125-493.125MHz (default 433.125MHz), using LoRa spread spectrum technology.

The module integrates functions such as (switch input) DI, (switch output) DO, (digital to analog converter) ADC, (analog-to-digital converter) DAC, (pulse width modulation) PWM, and (remote radio) LoRa. Users can control it by sending Modbus RTU commands through serial ports or remote LoRa networking devices, and also support low-power mode.

The module supports LoRa direct sequence spread spectrum technology, which has the advantages of longer communication distance, strong anti-interference ability, and extremely strong confidentiality; Industrial grade passive crystal oscillator ensures its stability and consistency.



1.2 Features

- Support advanced LoRa modulation method, with the advantage of long-distance anti-interference;
- Under ideal conditions, the communication distance of E150-400T22S can reach 5.6km;
- E150-400T30S is equipped with PA+LNA, and under ideal conditions, the communication distance can reach 10km.
- It supports 3.3-5.5V power supply and ensures optimal performance for power supplies greater than 5V;
- Support air wake-up (ultra-low power consumption), suitable for battery applications;
- The maximum transmit power is 1W, and the software can be adjusted in multiple levels;
- Support global license-free ISM 433MHz frequency band, frequency range: 410.125 ~ 493.125MHz, channel spacing 1MHz;
- Support data transmission rate of 2.4k~62.5kbps;
- Support 3.3~5.2V power supply, and the best performance can be guaranteed if the power supply is greater than 5V;
- Support standard Modbus RTU protocol;
- Support various configuration software/PLC/touch screen;
- 4-way switch input DI;
- 4-way switch output DO (DO1, DO2 open-drain output, DO3, DO4 push-pull output);
- 5-channel 12-bit ADC channel acquisition (2-channel voltage acquisition, 1-channel power supply voltage acquisition and 2-channel current acquisition);

- 2-channel 8-bit DAC output, only supports floating-point voltage value output;
- 2-channel PWM output, frequency range 25 Hz ~ 65535 Hz, multi-level duty cycle adjustable;
- Support 1~247 Modbus address settings, 0 is the public address;
- Support sending non-local Modbus addresses to other networked LoRa devices;
- Support transparent transmission of non-Modbus commands;
- UART to RS485 control pin (external conversion chip is required);
- Support 1200, 2400, 4800, 9600, 19200, 38400, 57600, 115200 and other baud rates;
- Support low power consumption mode;
- Support direct access of E22 series modules;
- Using industrial-grade crystal oscillator, industrial-grade standard design, support long-term use at -40 ~ +85 °C;
- IPEX interface, external antenna can be installed.

1.3 Application scenarios

- Application of industrial PLC Modbus RTU;
- Smart home and industrial sensors, etc.;
- Wireless alarm security system;
- Building automation solutions;
- Wireless industrial grade remote control;

Chapter 2 Specifications

2.1 Limit parameters

E150-400T22S main parameters:

The main parameters	Data sheet		Notes
	Min	Max	
voltage	0 V	5.5 V	Exceeding 5.5V may permanently burn the module
blocking power	-	10 dBm	The probability of burning at close range is small
Operating temperature	-40 °C	+85 °C	Industrial grade
ADC maximum input voltage	0 V	7.5 V	ADC1、ADC2、ADC3
ADC maximum input circuit	0 mA	25 mA	ADC4、ADC5
ADC minimum operating voltage	2.5 V	-	Below this supply voltage, the ADC works abnormally
DAC minimum operating voltage	3.3 V		Below this supply voltage, the DAC works abnormally
RF Minimum Operating Voltage	2.0 V	-	Below this supply voltage, the RF section stops working

150-400T30S main parameters:

The main parameters	Data sheet		Notes
	Min	Max	
voltage	0 V	5.5 V	Exceeding 5.5V may permanently burn the module
blocking power	-	10 dBm	The probability of burning at close range is small
Operating temperature	-40 °C	+85 °C	Industrial grade
ADC maximum input voltage	0 V	6 V	ADC1、ADC2、ADC3
ADC maximum input circuit	0 mA	25 mA	ADC4、ADC5
ADC minimum operating voltage	3.0 V	-	Below this supply voltage, the ADC works abnormally
DAC minimum operating voltage	3.3 V		Below this supply voltage, the DAC works abnormally
RF Minimum Operating Voltage	2.65 V	-	Below this supply voltage, the RF section stops working

2.2 Working parameters

150-400T22S main parameters:

main parameters	performance			Notes
	Min	Typical value	Max	

Operating Voltage (V)		3.3	5.0	5.5	≥3.3V Can ensure normal functionality
communication level (V)			3.3		Risk of burnout with 5V TTL
Operating temperature (°C)		-40	-	+85	Industrial grade design
Working frequency (MHz)		410.125	-	493.125	Supports ISM bands
power dissipation	Emission current (mA)	-	120		Instantaneous power consumption
	Working current (mA)		13		
	sleep current (μA)		6		software shutdown
Maximum transmit power (dBm)		21	21.5	22	User can configure
Receive sensitivity (dBm)		-145	-147	-148	The air rate is 2.4kbps
air speed (bps)		2.4k	2.4k	62.5k	User can configure
ADC voltage range (V)		0	-	5	Exceeding this range may cause damage to the ADC
ADC current range (mA)		0	-	20	Exceeding this range may cause damage to the ADC
DAC pin drive capability (mA)				-	Weak, an external voltage follower may be required according to user needs
DO1/DO2 drive capability (mA)				-	Open-drain output, drive capability depends on external pull-up resistor
DO3/DO4 Drive capability (mA)		-35		12	Push-pull output
Input voltageDI (V)		0		3.3	Exceeding this voltage may cause damage to the DI

150-400T30S main parameters:

E150-400T22S main parameters	performance			Notes	
	Min	Typical value	Max		
Operating Voltage (V)	3.3	5.0	5.5	≥5.0V Guaranteed output power (RF)	
communication level (V)		3.3		Risk of burnout with 5V TTL	
Operating temperature (°C)	-40	-	+85	Industrial grade design	
Working frequency (MHz)	410.125	-	493.125	Supports ISM bands	
power dissipation	Emission current (mA)	-	750	900	Instantaneous power consumption
	Working current (mA)	13	15	17	
	sleep current (μA)		6		software shutdown
Maximum transmit power (dBm)		28	30	31	User can configure
Receive sensitivity (dBm)		-145	-147	-148	The air rate is 2.4kbps
air speed (bps)		2.4k	2.4k	62.5k	User can configure
ADC voltage range (V)		0	-	5	Exceeding this range may cause damage to the ADC

ADC current range (mA)	0	-	20	Exceeding this range may cause damage to the ADC
DAC pin drive capability (mA)			-	Weak, an external voltage follower may be required according to user needs
DO1/DO2 drive capability (mA)			-	Open-drain output, drive capability depends on external pull-up resistor
DO3/DO4 Drive capability (mA)	-35		12	Push-pull output
Input voltageDI (V)	0		3.3	Exceeding this voltage may cause damage to the DI

Main parameters	Description	Notes
E150-400T22S Distance	5.6km	Clear and open environment, antenna gain 5dBi, antenna height 2.5 meters, air rate 2.4kbps
E150-400T30S Distance	10km	
ADC accuracy	12 bits	Built-in external reference voltage and voltage follower, the power supply voltage needs to be $\geq 3.0V$, and the accuracy is 1%
DAC accuracy	8 bits	Floating point value, the power supply voltage needs to be $\geq 3.3V$, the accuracy is 1%
PWM precision	Frequency step: 1 Hz Duty cycle step: 1%	Frequency range: 25Hz~65535Hz, accuracy 1% Duty cycle range: 0~100%, accuracy 1%
Subcontracting	240 Btye	The maximum capacity of a single package, after it is exceeded, it will be automatically divided into packages
Cache capacity	1024 Btye	
Modulation	LoRa	
Communication Interface	UART serial port	3.3V TTL level
Packaging method	SMD	
interface	UART	The user can connect an RS485 adapter chip, and the control pin has been led out
E150-400T22S Dimensions	31.0*18.0	Tolerance $\pm 0.2mm$ (excluding pin header height)
E150-400T30S Dimensions	40.5*25.0	Tolerance $\pm 0.2mm$ (excluding pin header height)
Antenna interface	IPEX/Stamp hole	Characteristic impedance about 50 ohms

Chapter 3 Mechanical Dimensions and Pin Definition

E150-400T22S:

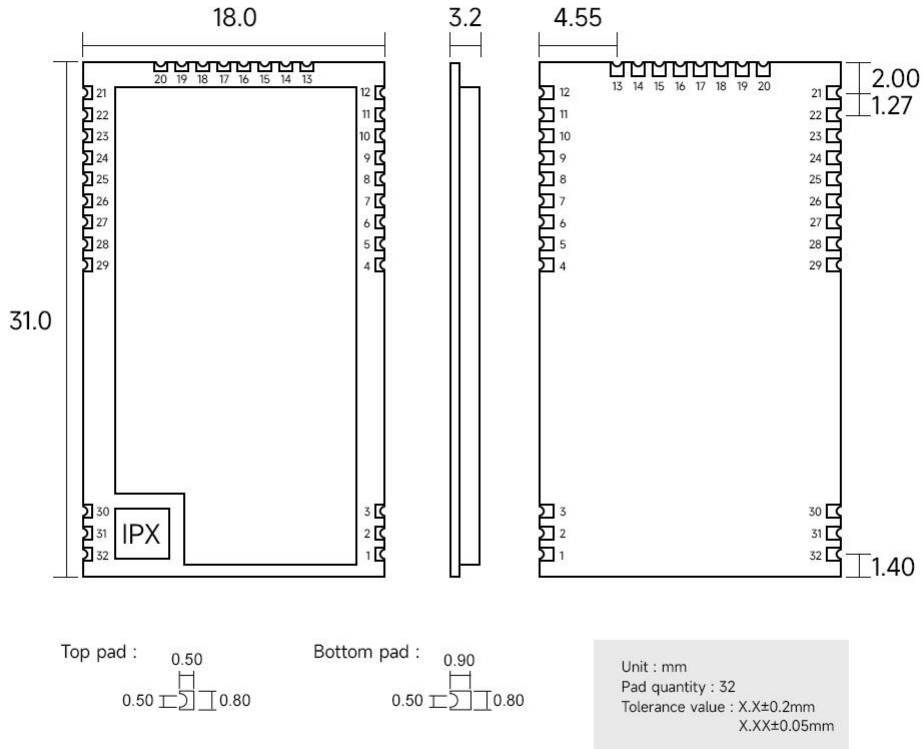

Pin number	Pin name	Pin direction	pin usage
1	GND	Input	Module power ground
2	GND	Input	Module power ground
3	GND	Input	Module power ground
4	PWM1	output	PWM Output
5	PWM2	output	PWM Output
6	GND	Input	Module power ground
7	DAC1	output	DAC output pin
8	DAC2	output	DAC output pin
9	ADC1	Input	ADC input pin for voltage measurement (0~5V)
10	ADC2	Input	ADC input pin for voltage measurement (0~5V)
11	ADC4	Input	ADC input pin for current measurement (0~20mA)
12	ADC5	Input	ADC input pin for current measurement (0~20mA)
13	DI1	Input (very weak pull-up)	Digital input, IO status can be inquired through Modbus commands

14	DI2	Input (very weak pull-up)	Digital input, IO status can be inquired through Modbus commands
15	DI3	Input (very weak pull-up)	Digital input, IO status can be inquired through Modbus commands
16	DI4	Input (very weak pull-up)t	Digital input, IO status can be inquired through Modbus commands
17	DO1	output (open drain)	Open leakage output, The E150-400T22S module has an external 1K pull-up resistor inside, so users do not need to install an external pull-up resistor
18	DO2	output (open drain)	Open leakage output,The E150-400T22S module has an external 1K pull-up resistor inside, so users do not need to install an external pull-up resistor
19	DO3	output (push-pull)	Push-pull output
20	DO4	output (push-pull)	Push-pull output
21	VCC	Input	Module power positive reference, voltage range: 3.3 ~ 5.5V DC
22	GND	Input	Module power ground
23	SWCLK	Input	SWD debug pin
24	NRST	Input	Reset module pin, it needs to be pulled low for at least 10 ms and then released to perform external reset
25	SWDIO	Input	SWD debug pin
26	485_EN	Output	When connecting an external UART to RS485 chip, this pin is used as the control terminal
27	AUX	Output	Used to indicate the working status of the module, or to wake up an external MCU
28	RXD	Input	TTL serial input, connect to external TXD output pin, pull-up input
29	TXD	Output	TTL serial output, connect to external RXD input pin
30	GND	Input	Module power ground
31	ANT	output/output	RF signal input/output terminal
32	GND	Input	Module power ground

E150-400T30S:

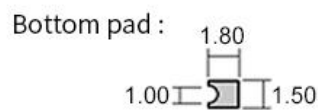
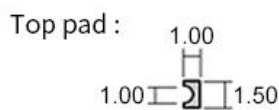
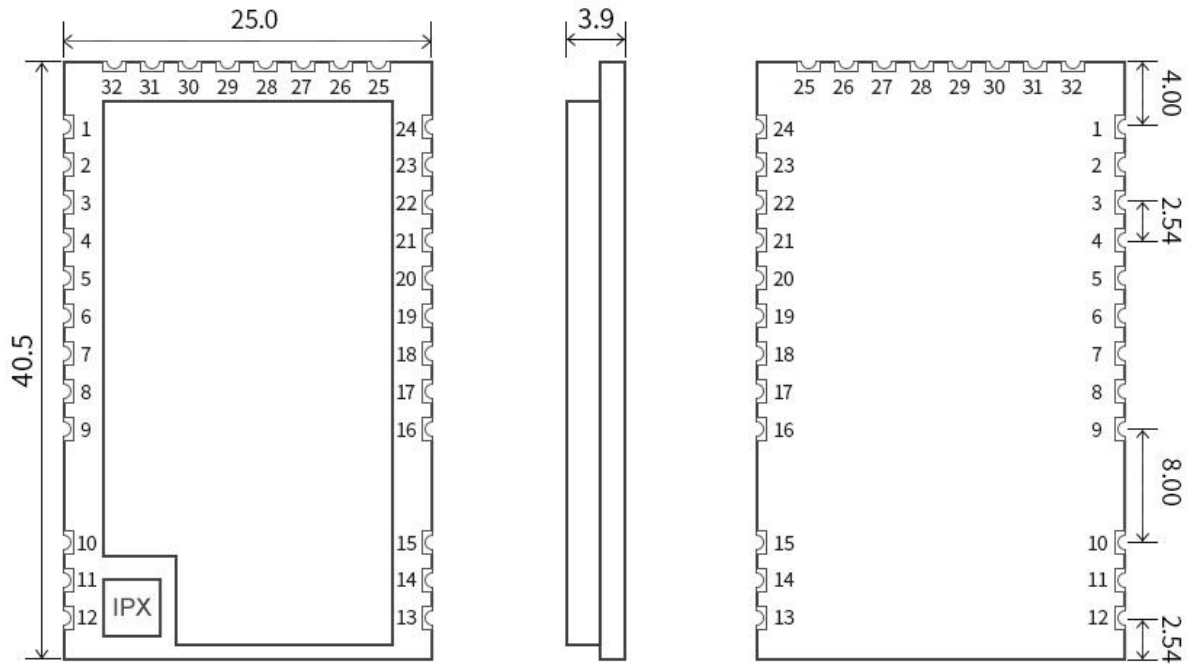

Unit : mm
 pad quantity : 32
 Tolerance value : X.X±0.1mm
 X.XX±0.05mm

Pin number	Pin name	Pin direction	pin usage
1	VCC	Input	Module power positive reference, voltage range: 3.3 ~ 5.5V DC
2	GND	Input	Module power ground
3	SWCLK	Input	SWD debug pin
4	NRST	Input	Reset module pin, it needs to be pulled low for at least 10 ms and then released to perform external reset
5	SWDIO	Input	SWD debug pin
6	485_EN	Output	When connecting an external UART to RS485 chip, this pin is used as the control terminal
7	AUX	Output	Used to indicate the working status of the module, or to wake up an external MCU
8	RXD	Input	TTL serial input, connect to external TXD output pin, pull-up input
9	TXD	Output	TTL serial output, connect to external RXD input pin
10	GND	Input	Module power ground

11	ANT	output/output	RF signal input/output terminal
12	GND	Input	Module power ground
13	GND	Input	Module power ground
14	GND	Input	Module power ground
15	GND	Input	Module power ground
16	PWM1	output	PWM Output
17	PWM2	output	PWM Output
18	GND	Input	Module power ground
19	DAC1	output	DAC output pin
20	DAC2	output	DAC output pin
21	ADC1	Input	ADC input pin for voltage measurement (0~5V)
22	ADC2	Input	ADC input pin for voltage measurement (0~5V)
23	ADC4	Input	ADC input pin for current measurement (0~20mA)
24	ADC5	Input	ADC input pin for current measurement (0~20mA)
25	DI1	Input (very weak pull-up)	Digital input, IO status can be inquired through Modbus commands
26	DI2	Input (very weak pull-up)	Digital input, IO status can be inquired through Modbus commands
27	DI3	Input (very weak pull-up)	Digital input, IO status can be inquired through Modbus commands
28	DI4	Input (very weak pull-up)t	Digital input, IO status can be inquired through Modbus commands
29	DO1	output (open drain)	Open leakage output, E150-400T30S must have an external pull-up resistor added, otherwise it cannot output high level;
30	DO2	output (open drain)	Open leakage output, E150-400T30S must have an external pull-up resistor added, otherwise it cannot output high level;
31	DO3	output (push-pull)	Push-pull output
32	DO4	output (push-pull)	Push-pull output

Chapter 4 Recommended Wiring Diagram

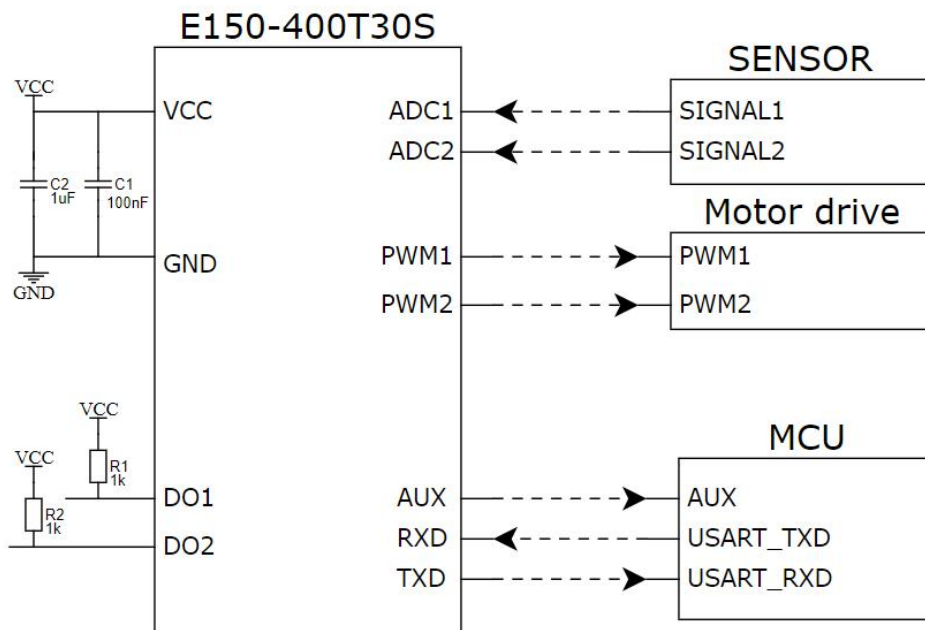
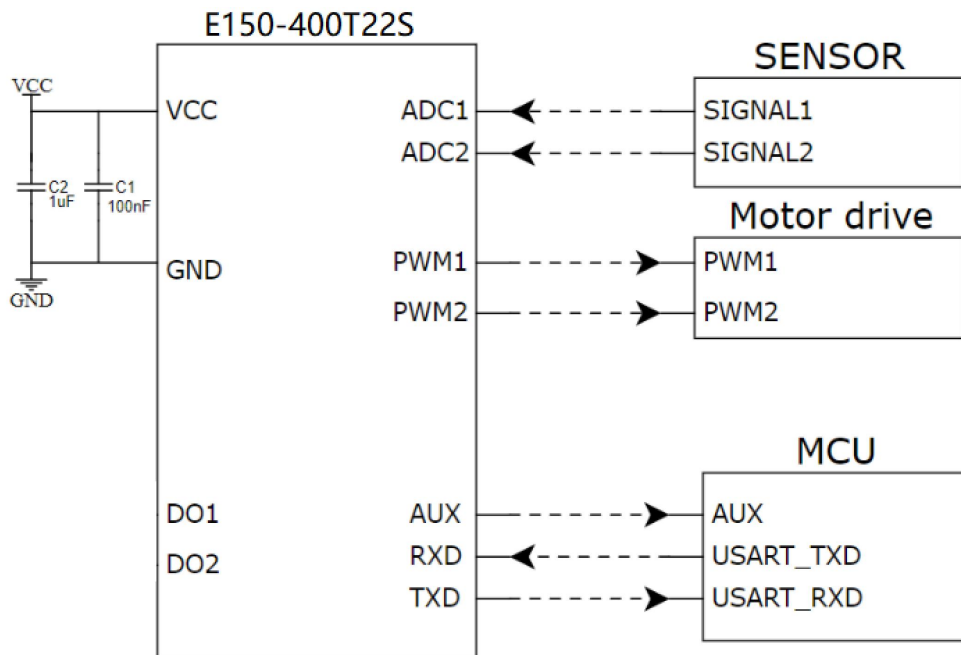

NUM.	A brief description of the connection between the module and the microcontroller (the above picture takes the STM8L microcontroller as an example)
1	The wireless serial port module is TTL level, please connect with 3.3V TTL level MCU.
2	When using a 5V microcontroller, please perform UART level conversion.
3	TVS protection and capacitors need to be added outside the power supply (it is recommended to add a 22uF low ESR electrolytic capacitor or tantalum capacitor)

4	The RF module is sensitive to pulsed static electricity. Do not hot-swap the module.
5	E150-400T30S recommends using a power supply of 10W (5V 2A) or above for power supply E150-400T22S recommends using a power supply of 2.5W (5V 0.5A) or higher for power supply
6	DO1 and DO2 are open drain output structures: E150-400T30S must have an external pull-up resistor added, otherwise it cannot output a high level; The E150-400T22S module is equipped with an external 1K pull-up resistor, so users do not need to install an external pull-up resistor.

Chapter 5 Introduction to Modbus RTU Commands

Modbus RTU has a total of 8 function codes (hexadecimal), and their meanings are as follows:

function code	illustration	function code	illustration
01	Read coil status	05	write coil status
02	Read discrete input	06	write a single register
03	read holding register	0F	write multiple coils
04	read input register	10	write multiple registers

E150-400TxxS modules can communicate with E22-400Txxx series modules wirelessly, but the following conditions must be met:

Both modules need to work in "transparent mode";

The parameters of "air rate", "channel address", "module address" and "network number" of both modules must be consistent;

The following commands related to remote wireless communication must meet the above conditions.

5.1 Read coil status

Using the read coil status (01) function code to read the output coil status, for example: read the status of do1 ~ do4

01	01	00 00	00 04	3D C9
Device MODBUS address	Function code	Register head address	Number of output coils read	CRC check code

CRC check code note: the CRC check code of the last two bytes of the sending instruction needs to be calculated by the user.

Serial port sending: 01 01 00 00 04 3D C9

Remote wireless transmission: 01 01 00 00 00 04 3D C9

After the above command is sent to the device through the serial port or wireless, the device will return the following values to the serial port or wireless:

01	01	01	0F	11 8C
Device MODBUS address	Function code	Number of bytes of data	Returned status data	CRC check code

The returned status data 0f indicates that the outputs do1 to do4 are at a high level.

Serial port receiving return value: 01 01 01 0f 11 8C

Remote wireless reception return value: 01 01 01 0f 11 8C

5.2 Control coil status

Support the operation of single coil (05) and multiple coils (0f) function codes.

- use 05 command to write a single coil, for example: do1 outputs high level

01	05	00 00	FF 00	8C 3A
Device MODBUS address	Function code	Register head address	Conduction: FF 00 Close: 00 00	CRC check code

Note: the CRC check code of the last two bytes of the sending instruction needs to be calculated by the user.

Serial port sending: 01 05 00 00 FF 00 8C 3A

Remote wireless transmission: 01 05 00 00 FF 00 8C 3A

After sending the above command to the device via serial port or wireless, the device will return the following values to the serial port or wireless:

01	05	00 00	FF 00	8C 3A
Device MODBUS address	Function code	Register head address	Operation mode	CRC check code

Phenomenon: DO1 output high level.

Serial port receiving return value: 01 05 00 00 FF 00 8C 3A

- Remote wireless reception return value: 01 01 01 0f 11 8C

use the 0f function code to write commands for multiple coils, for example: do1 ~ do4 output high level

01	0F	00 00	00 04	01	0F	7E 92
Device MODBUS address	Function code	Starting address:	Number of coils	Data bytes	Number of control coils Data (bit operation)	CRC check code

Note: the CRC check code of the last two bytes of the sending instruction needs to be calculated by the user.

Serial port sending: 01 0f 00 00 04 01 0f 7e 92

Remote wireless transmission: 01 0f 00 00 04 01 0f 7e 92

After sending the above command to the device via serial port or wireless, the device will return the following values to the serial port or wireless:

01	0F	00 00	00 04	C8 3F
Device MODBUS address	Function code	Register head address	Number of registers read	CRC check code

Phenomenon: do1 ~ D04 output high level.

Serial port receiving return value: 01 0f 00 00 04 C8 3F

Remote wireless reception return value: 01 0f 00 00 04 C8 3F

5.3 Read input register status

- use the 04 function code to read one or more input register values, for example: read the current floating-point voltage value

(power supply voltage) of adc3

01	04	00 CC	00 02	B1 F4
Device MODBUS address	Function code	Register head address	Number of registers read	CRC check code

Note: the CRC check code of the last two bytes of the sending instruction needs to be calculated by the user.

Serial port sending: 01 04 00 CC 00 02 B1 F4

Remote wireless transmission: 01 04 00 CC 00 02 B1 F4

After sending the above command to the device via serial port or wireless, the device will return the following values to the serial port or wireless:

01	04	04	40 85 E5 5E	35 00
Device MODBUS address	Function code	Number of bytes of data	Returned data	CRC check code

Phenomenon: the value of the return power supply voltage is 4.18425v (floating-point type 4085 e55e).

Serial port receive return value: 01 04 04 40 85 E5 5E 35 00

Remote wireless reception return value: 01 04 04 40 85 E5 5E 35 00

5.4 Read hold register

- use 03 function code to read one or more register values, for example: read the current baud rate

01	03	0B 72	00 01	26 35
Device MODBUS address	Function code	Register head address	Number of registers read	CRC check code

Note: the CRC check code of the last two bytes of the sending instruction needs to be calculated by the user.

Serial port sending: 01 03 0b 72 00 01 26 35

Remote wireless transmission: 01 03 0b 72 00 01 26 35

After sending the above command to the device via serial port or wireless, the device will return the following values to the serial port or wireless:

01	03	02	00 03	F8 45
Device MODBUS address	Function code	Number of bytes of data	Returned data	CRC check code

Phenomenon: return the baud rate value, 03 represents the baud rate of 9600 bps.

Serial port receiving return value: 01 03 02 00 03 F8 45

Remote wireless reception return value: 01 03 02 00 03 F8 45

5.5 Operation holding register

It supports the function code operation of operating a single register (06) and operating multiple registers (10).

- Using 06 function code to write a single holding register, for example: set to change the working mode of the equipment

01	06	07 E8	00 00	F8 8A
Device MODBUS address	Function code	Register address	Write value	CRC check code

Note: the CRC check code of the last two bytes of the sending instruction needs to be calculated by the user.

Serial port sending: 01 06 07 E8 00 00 F8 8A

Remote wireless transmission: 01 06 07 E8 00 00 F8 8A

After sending the above command to the device via serial port or wireless, the device will return the following values to the serial port or wireless:

01	06	07 E8	00 00	F8 8A
Device MODBUS address	Function code	Register address	Write value	CRC check code

Phenomenon: switch the working mode of the module to the normal mode.

Serial port receiving return value: 01 06 07 E8 00 00 F8 8A

Remote wireless reception return value: 01 06 07 E8 00 00 F8 8A

- command to write multiple holding registers using 10 function code, for example: set the output voltage value of dac1 to 1.2V.

01	10	00 00	00 02	04	3F 99 99 9A	C5 AF
Device MODBUS address	Function code	Register head address	Number of registers	Number of Bytes written	Data written	CRC check code

Note: the CRC check code of the last two bytes of the sending instruction needs to be calculated by the user.

Serial port sending: 01 10 00 00 00 02 04 3F 99 99 9A C5 AF

Remote wireless transmission: 01 06 07 E8 00 00 F8 8A

After sending the above command to the device via serial port or wireless, the device will return the following values to the serial port or wireless:

01	10	00 00	00 02	41 C8
Device MODBUS address	Function code	Register address	Number of registers	CRC check code

Phenomenon: The DAC1 pin of the module outputs a voltage of 1.2V.

Serial port receiving return value: 01 10 00 00 00 02 41 C8

Remote wireless reception return value: 01 10 00 00 00 02 41 C8

5.6 Broadcast address

When the module receives commands in non MODBUS format, it will send the received data as transparent data.

For example: set the address of module a to 0xFFFF and the channel to 0x04.

When module a is used as the transmitter (the same mode, transparent transmission mode), all receiving modules under 0x04 channel can receive data to achieve the purpose of broadcasting.

5.7 Listening address

For example: set the address of module a to 0xFFFF and the channel to 0x04.

When module a is used as the receiver, it can receive all the data under channel 0x04 to achieve the purpose of monitoring.

5.8 Module reset

Reset using the hardware NRST pin. The built-in MCU needs to be pulled down for at least 10 ms before being released to reset the MCU.

Using MODBUS command to reset (01 06 07 EA 5B B5 53 CD), that is, write 0x5bb5 to register 07ea h to enter watchdog reset, and the module will restart after a period of time.

5.9 Aux details

Aux will be pulled down in the following cases:

- Power on and enter the initialization process
- Data received through serial port
- Serial port is sending data
- RF is sending data
- Saving data to flash

5.9.1 Serial port data output indication

- When UART needs to send data, aux will be pulled down about 5ms in advance to wake up the external MCU in sleep.
- When the module receives the RF signal, it will delay about 10ms to wait for the sending module to be ready, and then reply through Lora or UART.
- When data is received at RF and needs to be output through UART, a delay of 15ms will pass.

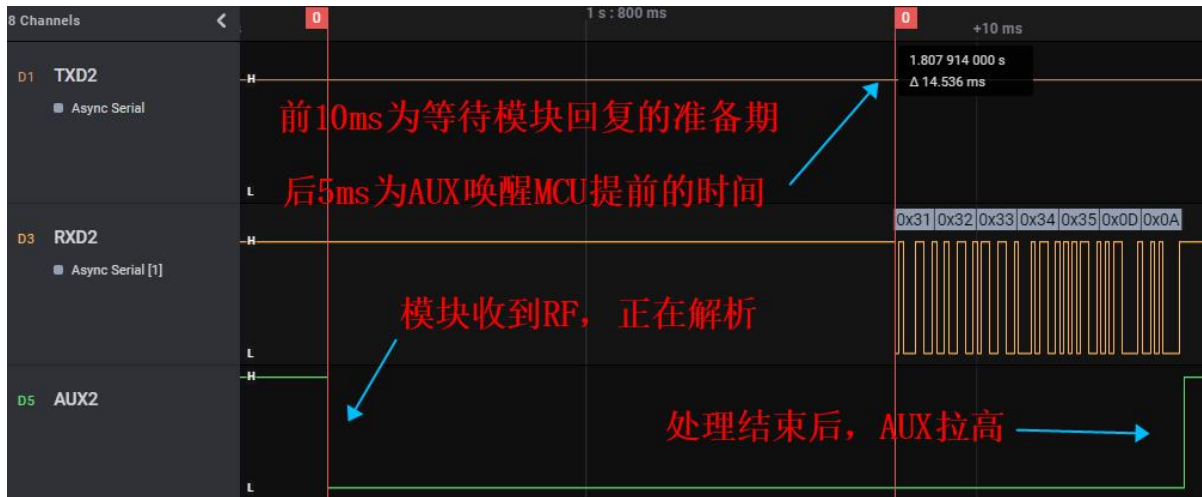

5.9.2 Work instructions

- when UART receives the non local MODBUS command or the first byte of the non MODBUS command, aux will be pulled down until RF transmission is completed.

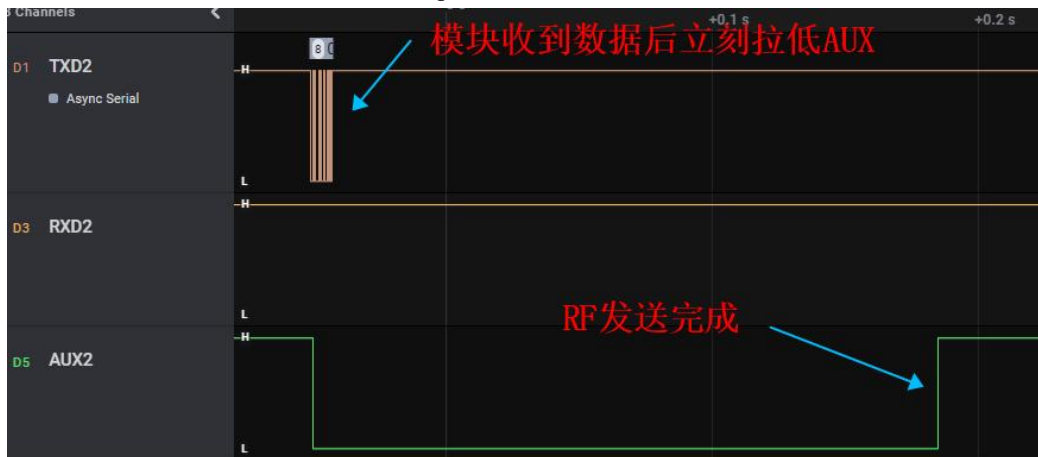

- when UART receives the first byte of the local MODBUS command, aux will be pulled down until the processing is completed.

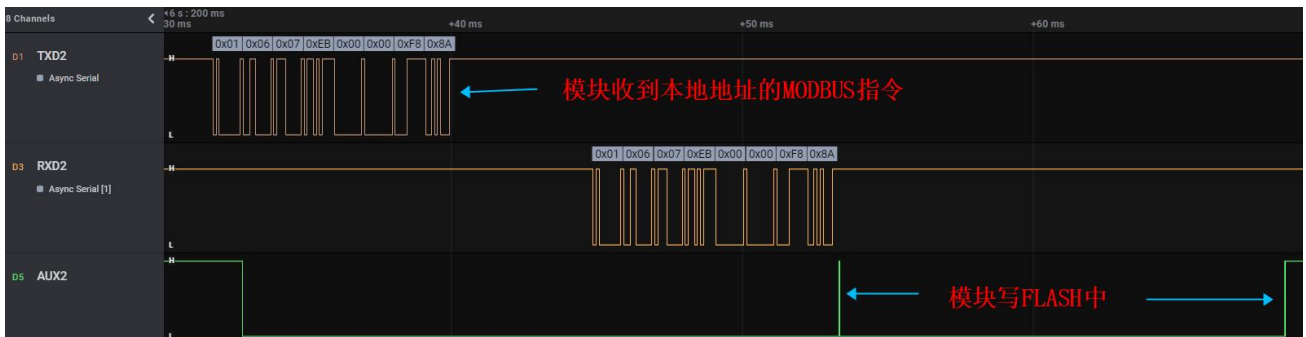

5.9.3 Module is in the process of configuration

- When resetting and switching modes, the aux pull-down time generated by resetting is generally about 11ms.

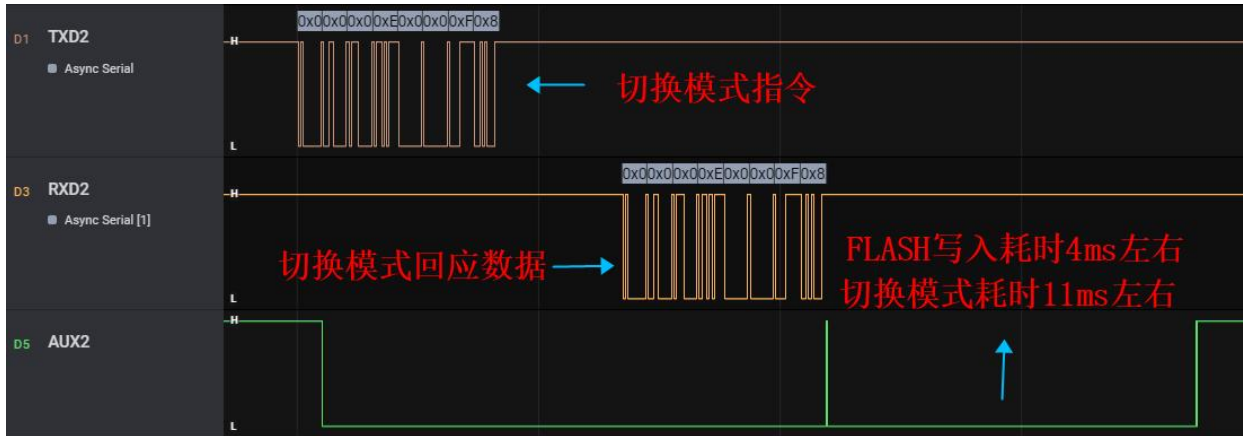

5.9.4 Flash write

- Many instructions will save parameters to flash when writing, so aux is required to indicate, so as to prevent the customer from sending data when writing in flash, resulting in write failure or failure to receive data normally. The write in flash operation is usually after the UART data is sent.

5.9.5 Complete process of reading IO status of other devices

- As shown in the figure, the time Lora sends the preamble can be modified according to the preamble register, and the preamble will not be added by default.
- If the customer needs to access the module in wor mode, the preamble register must be configured, and the length of the preamble must be greater than or equal to the wor cycle.

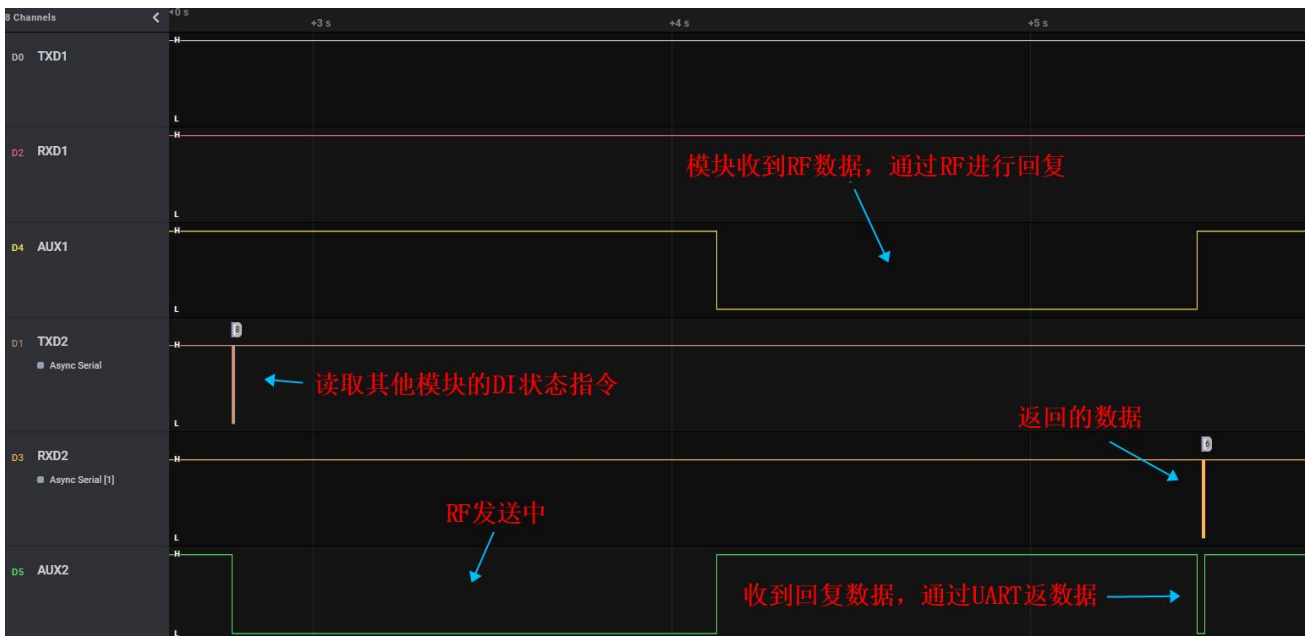

5.9.6 Lora sends data continuously

- When customers need to send long data continuously, they can choose to directly pour more than 240 bytes of data into the serial port. The module will automatically subcontract the data when processing the data. The sequence of aux is shown in the following figure:

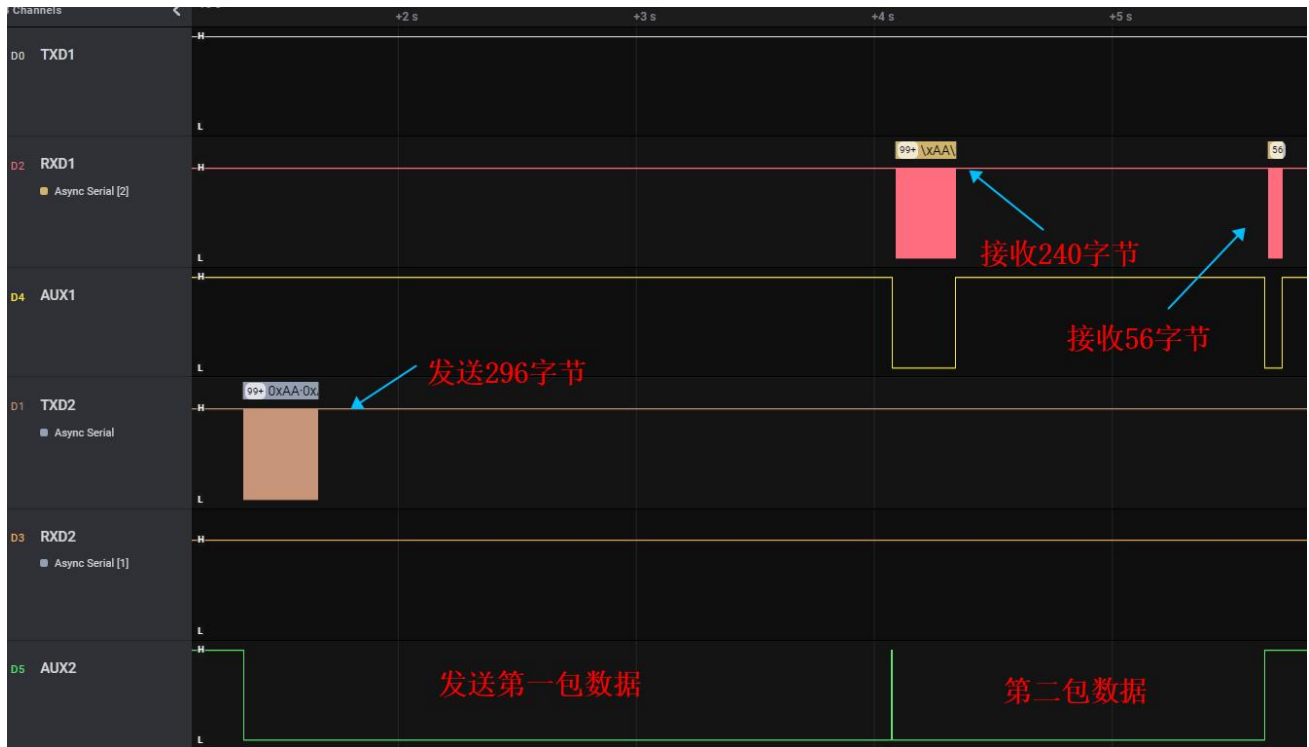

5.9.7 Aux precautions

- In the process of aux being pulled down, it is not recommended to operate the module, which may lead to some unknown problems;
- Aux is generally used as an indicator or as a judgment indicator of the working state;
- The aux timing in debug mode may be different. Please take the non debug mode as the standard.

Chapter 6 working mode

The module has three working modes, which are controlled and set by the device mode register; Details are shown in the table below:

Mode (0-2)	Mode introduction	Remark	Instruction (take address 01 as an example)
0 normal mode	1. The serial port is turned on, the wireless port is turned on, and all kinds of peripherals are turned on 2. If the receiver is operating in mode 1, the preamble register needs to be configured to use Lora for remote access	Receiver works in mode 0 and 1	01 06 07 EB 00 00 F8 8A
(1) Wor mode	1. According to the wor cycle register, periodically wake up the MCU to enter the receiving mode 2. Wor mode cannot actively transmit RF, but can passively reply RF data 3. The serial port must be awakened according to the sequence to work	Receiver works in mode 0 and 1	01 06 07 EB 00 01 39 4A
(2) sleep mode	1. The serial port must be awakened according to the sequence to work 2. All peripherals sleep 3. All IO states are forced to change, please refer to the pin state of sleep mode	All peripherals go to sleep	01 06 07 EB 00 02 79 4B

6.1 UART sleep wake

- when working in wor mode or sleep mode, you need to wake up the module according to a specific timing. You can use any baud rate before entering sleep. If the baud rate is less than 9600, it is recommended to directly use the command of switching mode to wake up. The wake-up process is as follows:

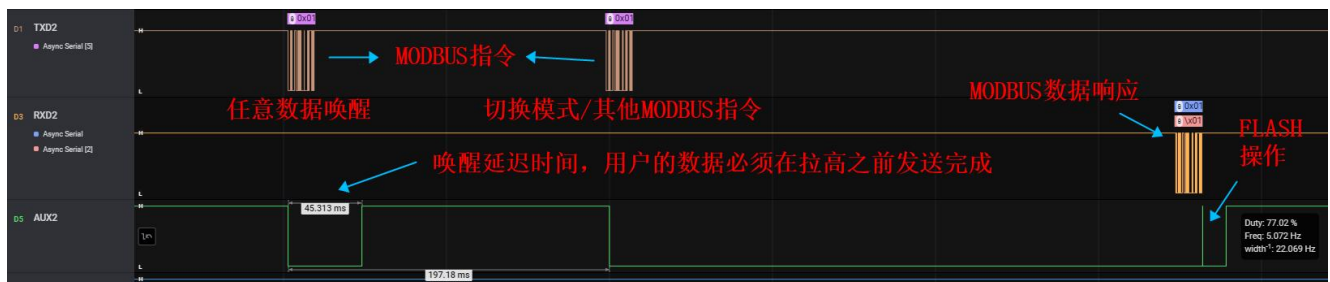

Wake up process: (the module is already working in wor mode or sleep mode, taking address 01 as an example)

- Send MODBUS command (command to switch mode to normal mode: 01 06 07 EB 00 00 F8 8a);
- After a delay of 50ms, send this command again to complete the mode switching. (Note 1)

matters needing attention:

- If the baud rate of the customer is 1200 BPs, a delay of 100ms is required, and the delay of 50ms is uniformly adopted for other baud rates;
- After the client wakes up by sending the first packet of data, the module will remain awake for about 500ms, and the client needs to complete the sending of serial port data within this time interval;
- Only in normal mode can RF transmission be started. In wor mode and sleep mode, RF data cannot be actively transmitted, but local MODBUS data can be processed;
- In wor mode, RF data can be passively sent, so the host can be placed in normal mode and directly access modules in wor mode;
- Modules in sleep mode, in addition to keeping awake, need to process all tasks before entering sleep again.
- It is forbidden for the sending time of the client wake-up packet to exceed the wake-up delay time, otherwise data errors will be caused.

6.4 WOR Mode (Mode 1)

type	When the device mode register = 1, the module operates in mode 1
LoRa transmitting	Cannot send actively, but can send passively (can only be mastered by mode 0) The preamble of the active sender must be greater than or equal to the WOR period of the receiver, otherwise the data will not be received The module does not add the length of the preamble by default, which needs to be set by the customer.
LoRa receiving	The module is periodically woken up by the low-power timer, and the control module enters the receiving mode. If it needs to reply data, it will reply through LoRa.
Wake up	Serial wake-up can be realized by using a certain timing sequence.

6.5 Sleep Mode (Mode 2)

Type	When the device mode register = 2, the module works in mode 2
LoRa transming	Unable to transmit wireless data.
LoRa receiving	Unable to receive wireless data.
Wake up	Serial wake-up can be realized by using a certain timing sequence

6.6 pin status

The default status of the module pins is as follows, you can use 00 06 07 E9 5B B5 A2 1C to restore the factory settings:

Peripheral pins	IO status	IO pin	IO status
AI all pins	analog input	AO all pins	Output 0.000V
DO1、 DO2	Open-drain output high	DO3、 DO4	push-pull output high
DI all pins	Input pull-up, enable interrupt	PWM all pins	Low output
RS485_EN	Low output	AUX	High output
TXD	TXD	RXD	RXD

- When the module enters sleep (WOR or sleep mode), all peripherals stop working, and all pin states are forcibly modified as shown below:

Peripheral pins	IO status	IO pin	IO status
AI all pins	Low output	AO all pins	Low output
DO1、 DO2	Open-drain output high	DO3、 DO4	push-pull output high
DI all pins	Input pull-up, close interrupt	PWM all pins	Low output
RS485_EN	Low output	AUX	High output
TXD	input pull-up	RXD	Input pull-up, enable

			interrupt
--	--	--	-----------

Chapter 7 MODBUS Address Table

Register function	initial address	Typye	number	Data range	Use function code
DO status	0x0000	Coil RW	1*4	0x05 function code: 0x0000/0xFF00 0x01/0x0F: function code 0x0000/0x0001	0x01、0x05、 0x0F
DO power-on state	0x0064	Coil RW	1*4	0x0000/0x0001 Default state of DO after device restart	0x01、0x05、 0x0F
DI status	0x0000	discrete input R	1*4	0x0000/0x0001 Represents read current DI status	0x02
AI Engineering value	0x0064	input register R	1*5	Analog signal shaping value (2 bytes) For example: 2.125V -> 2125 -> 084D H	0x04
AI floating point value	0x00C8	input register R	2*5	Analog signal floating point value (4 bytes) For example: 2.125V -> 0x4008 0x0000	0x04
AO floating point value	0x0000	holding register RW	2*2	Analog signal floating point value (4 bytes) For example: 2.125V -> 0x4008 0x0000	0x03、0x06、 0x10
AO Power-up floating point value	0x00C8	holding register RW	2*2	AO output default value after device restart	0x03、0x06、 0x10
DO Power-on hold	0x06A4	holding register RW	1*4	0x0000: Restart to restore default state 0x0001: Restart to restore the last state	0x03、0x06、 0x10
AO output hold	0x0708	holding register RW	1*2	0x0000: Restart to restore default state 0x0001: Restart to restore the last state	0x03、0x06、 0x10
PWM output hold	0x076C	holding register RW	1*2	0x0000: Restart to restore default state 0x0001: Restart to restore the last state	0x03、0x06、 0x10
PWM duty cycle	0x1770	holding register RW	1*2	0x00: output low level 0x64: output high level 0x01~0x63: duty cycle	0x03、0x06、 0x10

PWM frequency	0x17A2	holding register RW	1*2	Range: 25 Hz~65535 Hz	0x03、0x06、 0x10
PWM initial level	0x17D4	holding register RW	1*2	0x00: low level 0x01: High level	0x03、0x06、 0x10
Module address	0x07E8	holding register RW	1	MODBUS address, default is 1 Range: 1~247	0x03、0x06、 0x10
reset	0x07E9	holding register W	1	Write 0x5BB5 Reset all settings to factory settings	0x06、0x10
Device restart	0x07EA	holding register W	1	Write 0x5BB5 Device reboots after a while	0x06、0x10
device mode	0x07EB	holding register RW	1	0x0000: normal mode (default) 0x0001: WOR mode 0x0002: Sleep mode	0x03、0x06、 0x10
Part number	0x07EE	holding register R	25	DEVTYPE=E150-400T30S\r\n	0x03
Module firmware	0x0807	holding register R	25	FWCODE=7409-0-10\r\n	0x03
Device address	0x0B6F	holding register RW	1	Device address (0~65535)	0x03、0x06、 0x10
website address	0x0B71	holding register RW	1	The network address of the device (0~255)	0x03、0x06、 0x10
baud rate	0x0B72	holding register RW	1	The baud rate of the device, default 9600The baud rate of the device, default 9600 0x00:1200 0x01:2400 0x02:4800 0x03:9600 0x04:19200 0x05:38400 0x06:57600 0x07:115200	0x03、0x06、 0x10
Serial port parameters	0x0B73	holding register RW	1	The serial port data format of the device (default 8N1)	0x03、0x06、 0x10
air speed	0x0B74	holding register RW	1	LoRa's airborne propagation speed, default 2.4K 0x00:2.4K 0x01:2.4K 0x02:2.4K 0x03:4.8K 0x04:9.6K 0x05:19.2K 0x06:38.4K 0x07:62.5K	0x03、0x06、 0x10
channel parameters	0x0B75	holding register RW	1	LoRa channel address (default frequency 433.125)	0x03、0x06、 0x10
Data RSSI	0x0B76	holding register RW	1	RSSI snapshot of received data	0x03、0x06、 0x10
Output Power	0x0B77	holding register RW	1	0x0000: highest (default) 0x0001: High 0x0002: Medium	0x03、0x06、 0x10

				0x0003: low	
WOR cycle	0x0B79	holding register RW	1	Default: 2000 ms 0x0000:500 ms 0x0001:1000 ms 0x0002:1500 ms 0x0003:2000 ms 0x0004:2500 ms 0x0005:3000 ms 0x0006:3500 ms 0x0007:4000 ms	0x03、0x06、 0x10
preamble length	0x0B7A	holding register RW	1	Default: 0 ms 0x0000:500 ms 0x0001:1000 ms 0x0002:1500 ms 0x0003:2000 ms 0x0004:2500 ms 0x0005:3000 ms 0x0006:3500 ms 0x0007:4000 ms 0x0008: 0 ms	0x03、0x06、 0x10
Timing reset time	0x0B7B	holding register RW	1	On by default Default reset time: 5 min	0x03、0x06、 0x10
Low airspeed optimization	0x0B7C	holding register RW	1	Unused	0x03、0x06、 0x10
Reset AUX indication	0x0B7D	holding register RW	1	AUX indication at RF reset 0x00: off (default) 0x01: on	0x03、0x06、 0x10
DEBUG mode	0x0B7E	holding register RW	1	DEBUG mode 0x00: off (default) 0x01: on	0x03、0x06、 0x10
key	0x0B7F	holding register RW	1	Unreadable, the read result is fixed to 00	0x03、0x06、 0x10

Note:

1. During debugging, if you can't judge why the module can't work normally, you can turn on debug mode, and then turn off this mode after debugging.
2. In debug mode, the serial port will only print out the completed actions of some modules, which will not affect the normal execution of the program.
3. The aux timing in the debug mode may be different from that in the non debug mode. The debug mode can only be used during customer debugging.
4. When the debug mode is enabled, the upper computer will not be compatible. At this time, it needs to use 00 06 0b 7e 00 00 EA 27 command to close it.
5. When the Modbus address is 00 (public address), the local module can be directly operated.
6. Disable the remote configuration mode to sleep mode (mode 2). Once the remote module enters sleep mode, it can only be awakened through the local serial port.
7. Data RSSI is only valid in transparent data

Chapter 8 module control

8.1 digital input (DI)

- E150-400TxxS has 4 pin digital input pin (DI)
- DI will be used as an interrupt pull-up input in normal mode, and the interrupt will be turned off in sleep mode to avoid waking up the module by mistake.
- Use the function code of reading coil status (01) to read the discrete input coil status

For example: read the status of DI1 ~ DI4

01	02	00 00	00 04	79 C9
Device Modbus address	function code	Register first address	Number of output coils read	CRC check code

Note:

The CRC check code of the last two bytes of the sending instruction needs to be calculated by the user.

Serial port sending: 01 02 00 00 04 79 C9

Remote wireless transmission: 01 02 00 00 00 04 79 C9

After sending the above command to the device via serial port or wireless, the device will return the following values to the serial port or wireless:

01	02	01	0F	E1 8C
Device Modbus address	function code	number of bytes of data	Status data returned	CRC check code

The above "returned status data" 0F means that the output DI1~DI4 are high level.

Serial port receive return value: 01 02 01 0F E1 8C

Remote wireless reception return value: 01 02 01 0F E1 8C

8.2 digital output (DO)

- E150-400TxxS has 4-pin digital output pin (DO)
- DO1 and DO2 are set as open drain outputs, and the E150-400T22S module has already been externally pulled up internally, so users do not need to add a pull-up resistor.
- DO1 and DO2 are set to open drain output, and E150-400T30S must add an external pull-up resistor when in use, with a maximum external pull-up voltage of 6V.
- DO3 and DO4 are set as push-pull output, and the output level is 0 / 3.3V
- Use the 0f function code to write commands for multiple coils

For example: DO1 ~ DO4 output high level

01	0F	00 00	00 04	01	0F	7E 92
Device Modbus address	function code	initial address	Number of coils	number of bytes of data	number of control coils data (bit operation)	CRC check code

Note:

The CRC check code of the last two bytes of the sending instruction needs to be calculated by the user.

Serial port sending: 01 0F 00 00 04 01 0F 7E 92

Remote wireless transmission: 01 0F 00 00 00 04 01 0F 7E 92

After sending the above command to the device via serial port or wireless, the device will return the following values to the serial port or wireless:

01	0F	00 00	00 04	C8 3F
Device Modbus address	function code	register address	Number of coils	CRC check code

Phenomenon: DO1 ~ D04 output high level.

Serial port receiving return value: 01 0F 00 00 00 04 C8 3F

Remote wireless reception return value: 01 0f 00 00 00 04 C8 3F

- In addition to this, do also has two controllers, which are used to control whether the last state needs to be restored after power on

DO Power-on hold	After the module is reset, the DO output state depends on
0x0000(default)	DO power-on state (coil)
0x0001	DO state (coil)

When the do power on holding register is 0x0001, flash will be updated every time the user changes the do status register.

If the customer needs to change the do status register frequently, it is not recommended to turn on this function to avoid reducing the service life of the module.

8.3 Analog Input (AI)

- E150-400TxxS has 5 analog input pins (AI), including 2 voltage acquisition, 1 power voltage acquisition and 2 current acquisition.
- The voltage acquisition circuit integrates the voltage follower and voltage dividing circuit as well as the external reference voltage to ensure the accuracy of the measurement results.
- The reference voltage of E150-400T22S is 2.5V. When the module power supply is less than 2.5V, the reference voltage will shift with the power supply, resulting in inaccurate measurement.
- The reference voltage of E150-400T30S is 3.0V. When the module power supply is less than 3.0V, the reference voltage will

shift with the power supply, resulting in inaccurate measurement.

Input pin	function
ADC1	Voltage acquisition input 1
ADC2	Voltage acquisition input 2
ADC3(internal connection)	Power supply voltage acquisition terminal (VCC supply voltage)
ADC4	Current acquisition input 1 (single-ended input)
ADC5	Current acquisition input 2 (single-ended input)

Register function	MODBUS address	Register function	MODBUS address
ADC1Integer value	0x0064	ADC1floating point value	0x00C8
ADC2Integer value	0x0065	ADC2floating point value	0x00CA
ADC3Integer value	0x0066	ADC3floating point value	0x00CC
ADC4Integer value	0x0067	ADC4floating point value	0x00CE
ADC5Integer value	0x0068	ADC5floating point value	0x00D1

- The user can select the data format through different MODBUS addresses
- When reading floating-point numbers, two MODBUS registers must be read continuously
- Use 04 function code to read one or more input register values

For example, 1: to read the current floating-point voltage value (power supply voltage) of adc3, two registers must be read continuously

01	04	00 CC	00 02	B1 F4
Device MODBUS address	Function code	Register first address	Number of registers read	CRC check code

Note:

The CRC check code of the last two bytes of the sending instruction needs to be calculated by the user. Serial port sending: 01 04 00 CC 00 02 B1 F4

Remote wireless transmission: 01 04 00 CC 00 02 B1 F4

After sending the above command to the device via serial port or wireless, the device will return the following values to the serial port or wireless:

01	04	04	40 85 E5 5E	35 00
Device MODBUS address	Function code	Number of bytes of data	Returned data	CRC check code

Phenomenon: the value of the return power supply voltage is 4.18425V (floating-point type 4085 E55E).

Serial port receive return value: 01 04 04 40 85 E5 5E 35 00

Remote wireless reception return value: 01 04 04 40 85 E5 5E 35 00

For example, 2: read the current integer voltage value (power supply voltage) of ADC3)

01	04	00 66	00 01	D1 D5
Device MODBUS address	Function code	Register head address	Number of registers read	CRC check code

Note:

the CRC check code of the last two bytes of the sending instruction needs to be calculated by the user.

Serial port sending: 01 04 00 66 00 01 D1 D5

Remote wireless transmission: 01 04 00 66 00 01 D1 D5

After sending the above command to the device via serial port or wireless, the device will return the following values to the serial port or wireless:

01	04	02	11 B6	34 D6
Device MODBUS address	Function code	Number of bytes of data	Returned data	CRC check code

Phenomenon: return the value of power supply voltage 4.528V (11B6 H) (floating point value * 1000).

Serial port sending: 01 04 02 11 B6 34 D6

Remote wireless transmission: 01 04 02 11 B6 34 D6

8.4 analog output (AO)

- E150-400TxxS has two analog output pins (AO)
- AO output voltage is controlled by floating-point number, with built-in voltage stabilization algorithm. The maximum output voltage is the power supply voltage
- When writing floating-point numbers, two MODBUS registers must be written continuously

Register function	MODBUS address
Dac1 output voltage floating point value	0x0000
Dac2 output voltage floating point value	0x0002

- Command to write multiple holding registers using 10 function code

For example, set the output voltage value of dac1 to 1.2V

01	10	00 00	00 02	04	3F 99 99 9A	C5 AF
Device MODBUS address	Function code	Register head address	Number of registers	Number of bytes written	Data written	CRC check code

Note:

The CRC check code of the last two bytes of the sending instruction needs to be calculated by the user.

Serial port sending: 01 10 00 00 00 02 04 3F 99 99 9A C5 AF

Remote wireless transmission: 01 10 00 00 00 02 04 3F 99 99 9A C5 AF

After sending the above command to the device via serial port or wireless, the device will return the following values to the serial port or wireless:

01	10	00 00	00 02	41 C8
Device MODBUS address	Function code	Register address	Number of registers	CRC check code

Phenomenon: the DAC1 pin of the module outputs a voltage of 1.2V.

Serial port sending: 01 10 00 00 00 02 41 C8

Remote wireless transmission: 01 10 00 00 00 02 41 C8

- In addition to this, Ao also has two controllers, which are used to control whether the last state needs to be restored after power on

AO Power on hold	After the module is reset, Ao output depends on
0x0000(默认)	Ao floating point value (holding register)
0x0001	Ao power on floating point value (holding register)

When AO power on holding register is 0x0001, flash will be updated every time the user changes AO status register.

If the customer needs to change the AO status register frequently, it is not recommended to turn on this function to avoid reducing the service life of the module.

8.5 pulse width modulation (PWM)

- E150-400TxxS has two channels of pulse width modulation (PWM) and operates independently
- PWM is mainly controlled by PWM duty ratio, PWM frequency and PWM initial level

Duty cycle= 0 %	Fixed output low level
Duty cycle = 1~ 99%	Output PWM signals with different duty ratios
Duty cycle = 100 %	Fixed output high level

- In addition to PWM, there are two controllers to control whether the last state needs to be restored after power on

PWM power on hold	After the module is reset, the PWM output depends on
0x0000(default)	PWM initial level (hold register)
0x0001	PWM duty cycle, PWM frequency, PWM initial level (hold register)

When the PWM power on hold register is 0x0001, the flash will be updated every time the user changes the PWM duty cycle or PWM frequency register.

If the customer needs to change the PWM duty ratio or PWM frequency register frequently, it is not recommended to turn on this function to avoid reducing the service life of the module.

For example, 1: output a square wave with low starting level, 20% duty cycle and 1000 Hz frequency

- ① Set the duty ratio to 20%

01	06	17 70	00 14	8D AA
----	----	-------	-------	-------

Device MODBUS address	Function code	Register address	Write value	CRC check code
-----------------------	---------------	------------------	-------------	----------------

② Set the frequency to 1000 Hz

01	06	17 A2	03 E8	2D 22
Device MODBUS address	Function code	Register address	Write value	CRC check code

③ Set initial level

01	06	17 D4	00 00	CC 46
Device MODBUS address	Function code	Register address	Write value	CRC check code

Note:

The CRC check code of the last two bytes of the sending instruction needs to be calculated by the user.

Serial port send:

01 06 17 70 00 14 8D AA

01 06 17 A2 03 E8 2D 22

01 06 17 D4 00 00 CC 46

Remote wireless transmission send:

01 06 17 70 00 14 8D AA

01 06 17 A2 03 E8 2D 22

01 06 17 D4 00 00 CC 46

8.6 RS485 pin

- RS485 requires external connection of UART to RS485 chip, and this pin is used as the control pin;
- When the module sends data, RS485 will be set high. In other cases, RS485 will be in the low state. The timing is as follows.

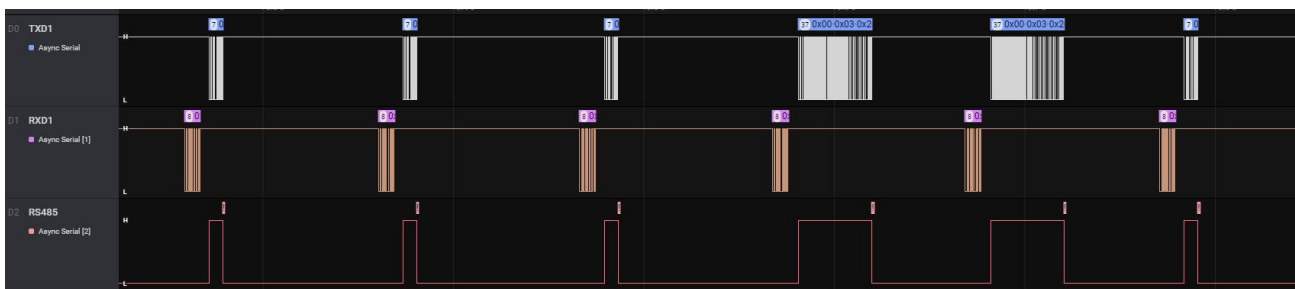

8.7 about floating point conversion

- Decimal to single precision floating-point number can use online converter, link: [online converter](#)

十进制(1.2)的单精度浮点数值: **3F999999**, (00111111100110011001100110011001)

请输入数值: 长度(1~25) **输出**

转换类型: 十进制转单精度浮点数 单精度浮点数转十进制 STM明渠流量计MODBUS协议返回包

开始转换

8.8 module use

- Each module has a public MODBUS address 00, which can directly operate the module
- Each module has a private MODBUS address in addition to the public address
- When using, users need to know the private MODBUS address of the device before remote access
- If the customer does not know the private MODBUS address of this device, the 00 public address can be used, and the 00 public address can only be recognized by the local device
- You can use 00 03 07 E8 00 01 04 9b to read the private MODBUS address of different modules
- Use 03 function code to read one or more register values, for example: read the current baud rate

01	03	0B 72	00 01	26 35
Device MODBUS address	Function code	Register head address	Number of registers read	CRC check code

Note: the CRC check code of the last two bytes of the sending instruction needs to be calculated by the user.

Serial port sending: 01 03 0b 72 00 01 26 35

Remote wireless transmission: 01 03 0b 72 00 01 26 35

After sending the above command to the device via serial port or wireless, the device will return the following values to the serial port or wireless:

01	03	02	00 03	F8 45
Device MODBUS address	Function code	Number of bytes of data	Returned data	CRC check code

- Phenomenon: return the baud rate value, 03 represents the baud rate of 9600 bps.
- Serial port sending: 01 03 02 00 03 F8 45
- Remote wireless transmission: 01 03 02 00 03 F8 45

8.9 interaction between modules

- When the module receives a MODBUS command from a non local address, it will broadcast Lora. After receiving the data, the receiving module will immediately command the Modbus command and reply again through Lora. After receiving the data, the sending end will send back the data of the receiving end through UART
- When using, the user needs to set the Modbus address of the device first, and the Modbus of different devices cannot be the same
- For example: 01 06 07 E8 00 02 89 4B (set the Modbus address of the device with MODBUS address 01 to 02)
- Send a MODBUS command of a non local address, and the module will automatically broadcast Lora. When the receiving end receives the data, it will execute the Modbus command of the response, and broadcast the returned data again. After receiving the reply data, the sending end will output the reply data through UART. The process is shown in the following figure:

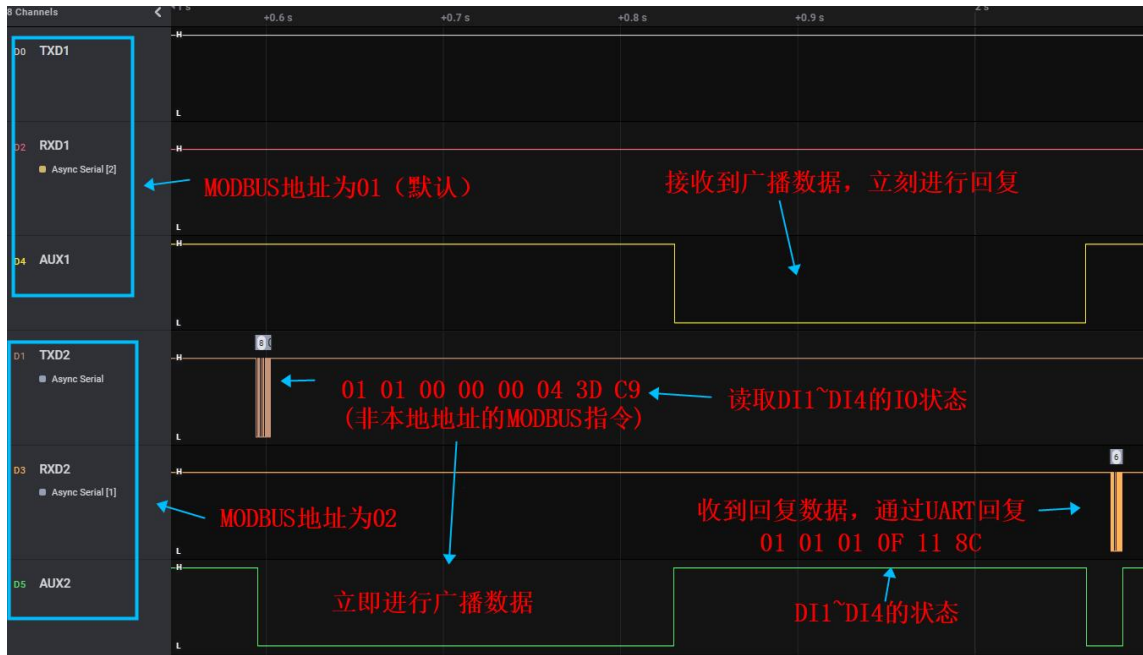

8.10 about flash operation

- DI, DO, AI, AO and CFG each occupy one page of flash, so updating different peripherals will not affect each other;
- Whenever the user uses MODBUS to read, flash will not be updated;
- Whenever the user uses MODBUS to write, generally, flash will be directly written for data saving, except for the following registers:

Do status	0x0000	Coil RW	1*4	When the do power on hold register is 0x01, Writing will automatically update flash	When the do power on hold register is 0x00, Writing does not update flash
Ao floating point value	0x0000	Holding register RW	2*2	When the Ao power on hold register is 0x01, Writing will automatically update flash	When the Ao power on hold register is 0x00, Writing does not update flash
PWM duty cycle	0x1770	Holding register RW	1*2	When the do power on hold register is 0x01, Writing will automatically update flash	When the do power on hold register is 0x00, Writing does not update flash
PWM frequency	0x17A2	Holding register RW	1*2	When the PWM power on hold register is 0x01, Writing will automatically update flash	When the PWM power on hold register is 0x00, Writing does not update flash

Chapter 9 introduction to upper computer

- The user can use the upper computer provided by the official website to control the module. When using the module, the user needs to virtualize the serial port of the module into a COM port. The upper computer interface is as follows. Spaces need to be reserved in the middle of hexadecimal parameters:

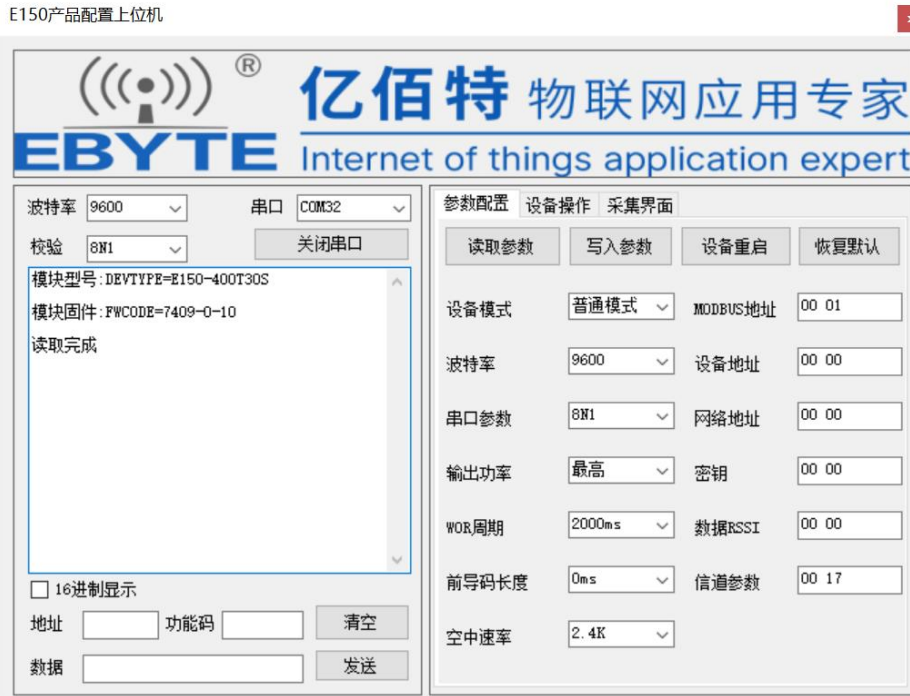

- The upper computer provides a MODBUS standard command interface. The user can use this interface to directly control various actions of the module. The check code will be automatically added in this area without calculation:

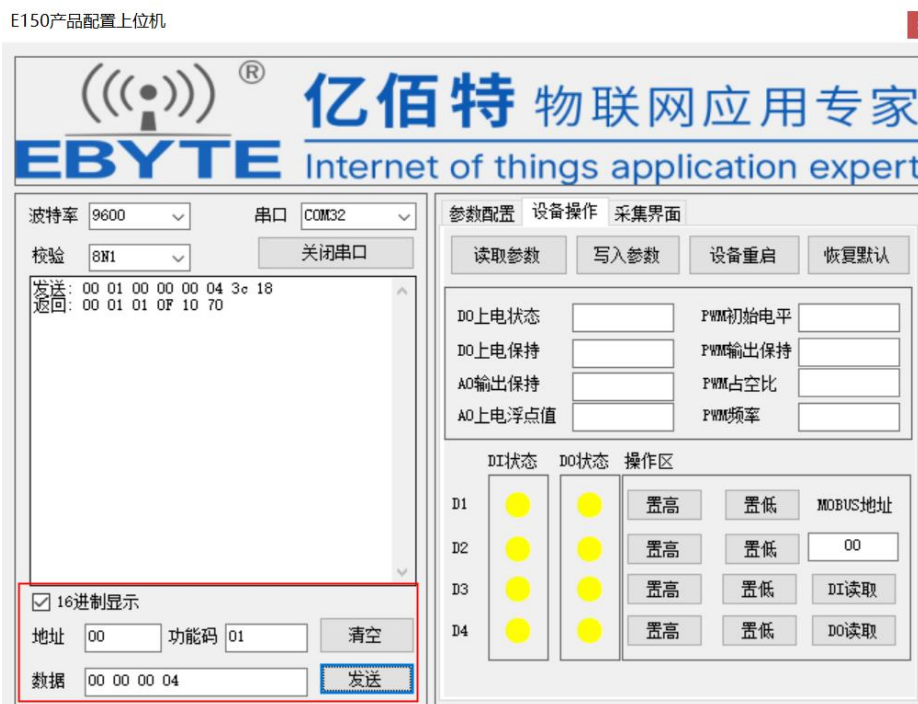

- The equipment operation interface can read the setting parameters of various local peripherals, and the format needs to be input in the following format;

- The user can read or control the status of the remote module di or do according to different MODBUS addresses;
- Among them, yellow represents unknown, green represents high level, and black represents low level;

- The acquisition interface can regularly collect various inputs of local or remote AI, and the interval is 3 s by default;
- AO output only supports floating-point input. Although the module will adjust the output according to different power supply voltages, the maximum output can only reach the power supply voltage.

Chapter 10 hardware design

- It is recommended to use a DC regulated power supply to supply power to the module. The ripple coefficient of the power supply should be as small as possible, and the module should be reliably grounded;
- Please pay attention to the correct connection of the positive and negative poles of the power supply. If reversed, the module may be permanently damaged;
- Please check the power supply to ensure that it is between the recommended power supply voltage. Exceeding the maximum value will cause permanent damage to the module;
- Please check the stability of the power supply, and the voltage cannot fluctuate greatly and frequently;
- When designing the power supply circuit for the module, it is often recommended to reserve more than 30% margin, which is conducive to the long-term stable operation of the whole machine;
- modules shall be far away from power supply, transformer, high-frequency wiring and other parts with large electromagnetic interference as far as possible;
- The high-frequency digital wiring, high-frequency analog wiring and power wiring must avoid the lower part of the module. If it is really necessary to pass through the lower part of the module, it is assumed that the module is welded on the top layer, and copper is laid on the top layer of the module contact part (all copper is laid and well grounded). It must be close to the digital part of the module and run on the bottom layer;
- Assuming that the module is welded or placed on the top layer, it is also wrong to randomly route on the bottom layer or other layers, which will affect the stray and receiving sensitivity of the module to varying degrees;
- It is assumed that there are devices with large electromagnetic interference around the module, which will greatly affect the performance of the module. It is recommended to stay away from the module properly according to the intensity of the interference. If the situation allows, it can be properly isolated and shielded;
- It is assumed that there are wiring with large electromagnetic interference (high-frequency digital, high-frequency analog, power wiring) around the module, which will also greatly affect the performance of the module. It is recommended to keep away from the module according to the intensity of interference. If the situation allows, it can be properly isolated and shielded;
- If the communication line uses 5V level, 1k-5.1k resistors must be connected in series (not recommended, there is still a risk of damage);
- Try to stay away from some TTL protocols whose physical layer is also 2.4GHz, such as USB3.0;
- The antenna installation structure has a great impact on the performance of the module, and the antenna must be exposed and preferably vertically upward;
- When the module is installed inside the cabinet, a high-quality antenna extension cable can be used to extend the antenna to the outside of the cabinet;
- The antenna must not be installed inside the metal shell, which will greatly weaken the transmission distance.

Chapter 11 common problems

11.1 the transmission distance is not ideal

- When there is a direct communication obstacle, the communication distance will be correspondingly attenuated;
- Temperature, humidity and co frequency interference will increase the packet loss rate of communication;
- The ground absorbs and reflects radio waves, and the test effect near the ground is poor;
- Sea water has a very strong ability to absorb radio waves, so the seaside test effect is poor;
- If there are metal objects near the antenna or placed in the metal shell, the signal attenuation will be very serious;
- Power register setting error, air speed setting too high (the higher the air speed, the closer the distance);
- At room temperature, the low voltage of the power supply is lower than the recommended value, and the lower the voltage, the smaller the power generation;
- The matching degree between the antenna and the module is poor or the quality of the antenna itself is poor.

11.2 module is easy to be damaged

- Please check the power supply to ensure that it is between the recommended power supply voltage. Exceeding the maximum value will cause permanent damage to the module;
- Please check the stability of the power supply, and the voltage cannot fluctuate greatly and frequently;
- please ensure anti-static operation during installation and use, and electrostatic sensitivity of high-frequency devices;
- Plase ensure that the humidity during installation and use should not be too high, and some components are humidity sensitive devices;
- If there is no special requirement, it is not recommended to use it at too high or too low temperature.

11.3 bit error rate is too high

- If there is interference of the same frequency signal nearby, stay away from the interference source or modify the frequency and channel to avoid interference;
- If the power supply is not ideal, it may also cause garbled code, and the reliability of the power supply must be guaranteed;
- Poor or too long extension lines and feeders will also cause high bit error rate.

Chapter 12 welding operation instructions

- This product is a patch type module. When welding the module, the welding personnel must follow the electrostatic discharge operation specifications.
- This product is an electrostatic sensitive product. If you don't weld the module according to the rules, the module may be permanently damaged.

12.1 Reflow temperature

Profile Feature	Curve characteristics	Sn-Pb Assembly	Pb-Free Assembly
Solder Paste	Solder paste	Sn63/Pb37	Sn96.5/Ag3/Cu0.5
Preheat Temperature min (T _{smin})	Minimum preheating temperature	100°C	150°C
Preheat temperature max (T _{smax})	Maximum preheating temperature	150°C	200°C
Preheat Time (T _{smin} to T _{smax})(ts)	Preheating time	60-120 sec	60-120 sec
Average ramp-up rate(T _{smax} to T _p)	Average rising rate	3°C/second max	3°C/second max
Liquidous Temperature (TL)	Liquid phase temperature	183°C	217°C
Time (t _L) Maintained Above (TL)	Time above the liquidus	60-90 sec	30-90 sec
Peak temperature (T _p)	Peak temperature	220-235°C	230-250°C
Average ramp-down rate (T _p to T _{smax})	Average rate of decline	6°C/second max	6°C/second max
Time 25°C to peak temperature	Time from 25 °C to peak temperature	6 minutes max	8 minutes max

12.2 Reflow soldering curve

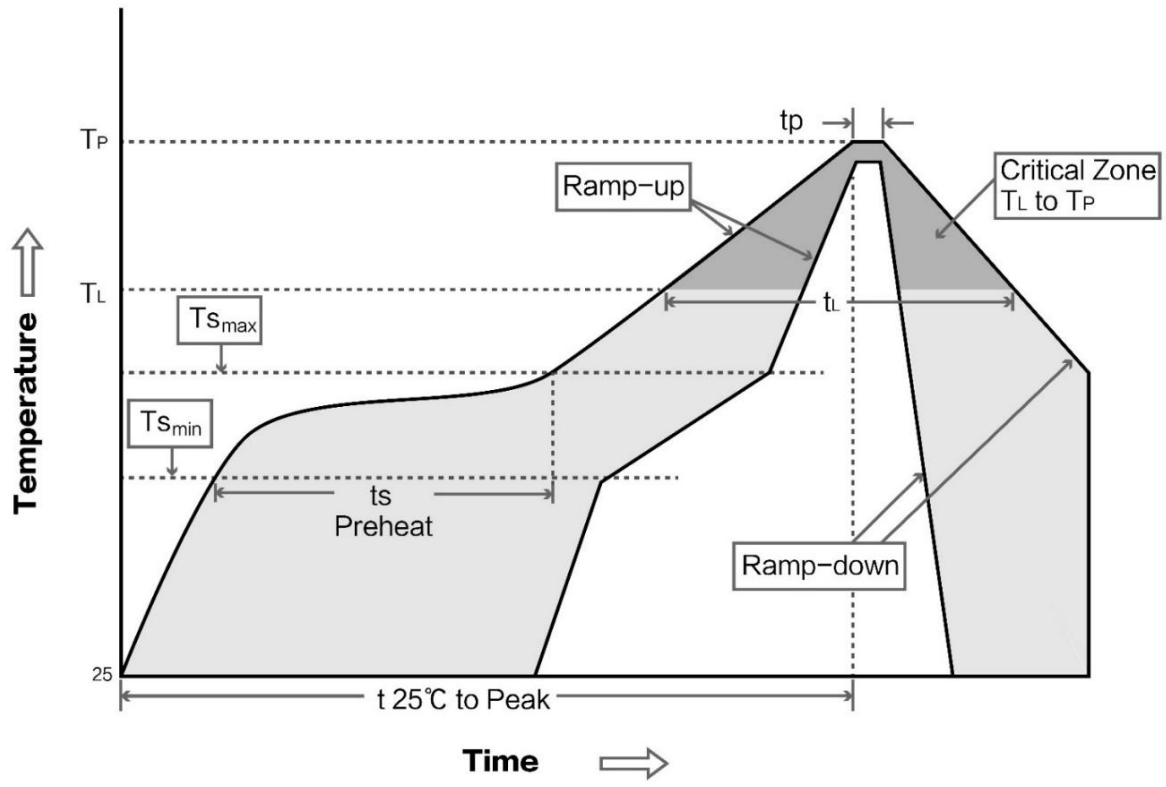

Chapter 13 relevant models

Product model	Carrier frequency (Hz)	Transmit power (DBM)	Test distance (km)	Air speed bps	Packaging form	Product size (mm)	Antenna form
E22-400T22S	433/470M	22	5	2.4k~62.5k	Patch	16*26	IPEX / stamp hole
E22-400T22D	433/470M	22	5	2.4k~62.5k	Direct insertion	21*36	SMA-K
E22-400T30S	433/470M	30	10	2.4k~62.5k	Patch	25*40.5	IPEX / stamp hole
E22-400T30D	433/470M	30	10	2.4k~62.5k	Direct insertion	24*43	SMA-K
E22-400T33S	433/470M	33	16	2.4k~62.5k	Patch	25*40.5	IPEX / stamp hole
E22-400T33D	433/470M	33	16	2.4k~62.5k	Direct insertion	37*60*7.6	SMA-K

Chapter 14 antenna guide

Antennas play an important role in the communication process, and often poor quality antennas will have a great impact on the communication system. Therefore, our company recommends some antennas as supporting wireless modules of our company, with better performance and reasonable price.

Product model	type	Frequency band	gain	size	feeder	Interface	characteristic
		Hz	dBi	mm	cm		
TX433-NP-4310	Flexible antenna	433M	2.0	10x43	-	welding	Flexible FPC soft antenna
TX433-JZ-5	Rubber rod antenna	433M	2.0	52	-	SMA-J	Ultra short straight, omnidirectional antenna
TX433-JZG-6	Rubber rod antenna	433M	2.5	62	-	SMA-J	Ultra short straight, omnidirectional antenna
TX433-JW-5	Rubber rod antenna	433M	2.0	50	-	SMA-J	Fixed bending, omnidirectional antenna
TX433-JWG-7	Rubber rod antenna	433M	2.5	70	-	SMA-J	Fixed bending, omnidirectional antenna
TX433-JK-11	Rubber rod antenna	433M	2.5	110	-	SMA-J	Bendable rubber rod, omnidirectional antenna
TX433-JK-20	Rubber rod antenna	433M	3.0	200	-	SMA-J	Bendable rubber rod, omnidirectional antenna
TX433-XPL-100	Sucker antenna	433M	3.5	185	100	SMA-J	Small sucker antenna, cost-effective
TX433-XP-200	Sucker antenna	433M	4.0	190	200	SMA-J	Small sucker antenna, low loss

TX433-XPB-300	Sucker antenna	433M	6.0	965	300	SMA-J	Small sucker antenna, high gain
-------------------------------	----------------	------	-----	-----	-----	-------	---------------------------------

Chapter 15 batch packaging method

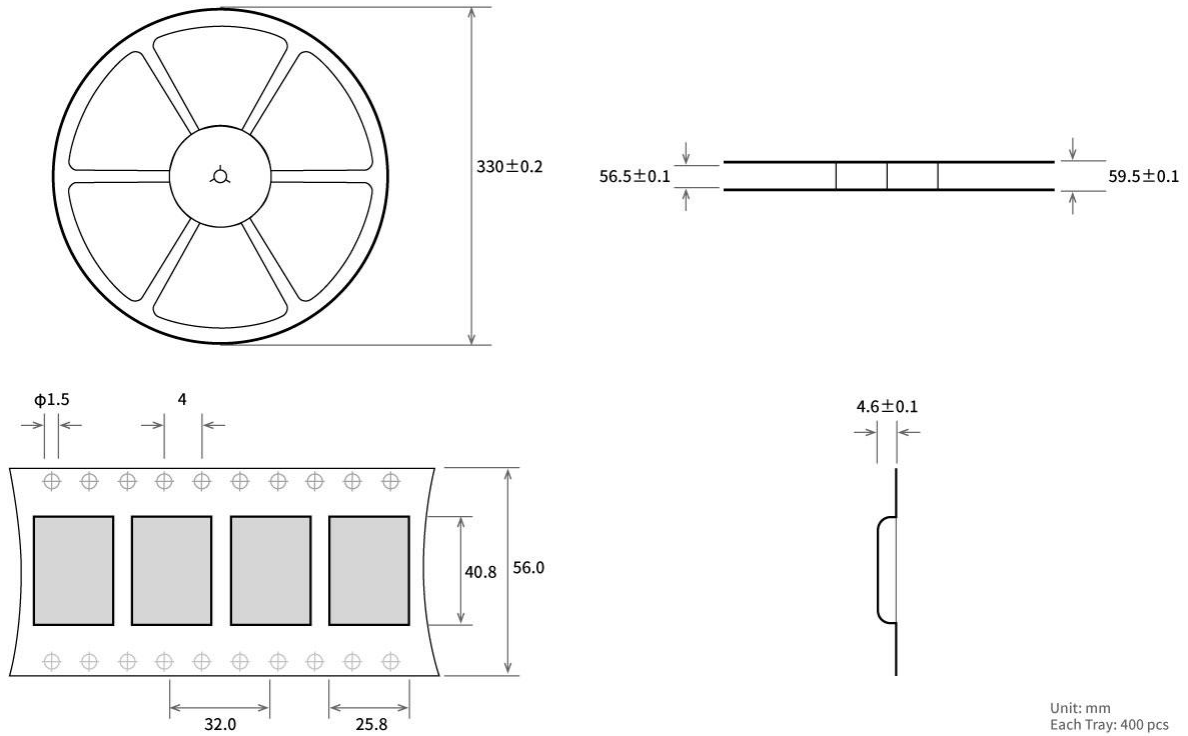

Revision history

edition	Revision date:	Revision Description:	Maintainer
1.0	2022-6-20	Initial version	Weng
1.1	2022-8-30	Add instruction description	Ning
1.3	2024-7-31	Added E150-400T22S	Bin

About us



Hot line:4000-330-990

Technical support: support@cdebyte.com

Thank you for using Ebyte products! Please contact us with any questions or suggestions:

info@cdebyte.com

Web:<https://www.cdebyte.com>

Address: B5 Mould Park, 199# Xiqu Ave, High-tech District, Sichuan, China

 **成都亿佰特电子科技有限公司**
EBYTE Chengdu Ebyte Electronic Technology Co.,Ltd.