

No.1688 Jiangxing East Road
WuJiang Economy Development Zone
Wujiang City Jiang Su Province,P.R.C.

TEL : 86-512-63406008
FAX : 86-512-63015608

STATEMENT OF DEVIATION

NONE

DESCRIPTION :

DELTA DOC CENTER

No.1688 Jiangxing East Road
Wujiang Economy Development Zone
Wujiang City Jiang Su Province,P.R.C.

TEL : 86-512-63406008
FAX : 86-512-63015608

Specification For Approval

Customer : DRM

Description : DC FAN

Customer P/N :

rev. :

Delta model no. : ASB0305HP-007HQ

Delta Safety Model No.: ASB0305HP-00

Sample revision. : 01

Issue no.:

Sample issue date : 11-28-2018

Quantity :

1. SCOPE:

THIS SPECIFICATION DEFINES THE ELECTRICAL AND MECHANICAL CHARACTERISTICS OF THE DC BRUSHLESS AXIAL FLOW FAN.

2. CHARACTERS:

ITEM	DESCRIPTION
RATED VOLTAGE	5.0V
OPERATION VOLTAGE	4.5 - 5.5 VDC
INPUT CURRENT(AVG.) #	0.20 (MAX 0.50) A (SAFETY CURRENT ON LABEL : 0.50A)
INPUT POWER(AVG.)	1.00 (MAX 2.5) W
SPEED	9500±15%R.P.M.
MAX. AIR FLOW (AT ZERO STATIC PRESSURE)	0.144 (MIN. 0.123) M3 /MIN. 5.10 (MIN. 4.34) CFM
MAX. AIR PRESSURE (AT ZERO AIRFLOW)	3.96 (MIN. 2.86) mmH2O 0.156 (MIN. 0.113) inchH2O
ACOUSTICAL NOISE (AVG.)	29.0 (MAX. 33.0) dB-A
INSULATION TYPE	UL: CLASS A
INSULATION STRENGT	10 MEG OHM MIN. AT 500 VDC (BETWEEN FRAME AND (+) TERMINAL)
DIELECTRIC STRENGTH	5 mA MAX. AT 500 VAC 50/60 Hz ONE MINUTE, (BETWEEN FRAME AND (+) TERMINAL)

THE MAX VALUE OF CONSUMING CURRENT DOES NOT REPRESENT THE PEAK VALUE
THE PEAK VALUE NEED MEASURE BY OSCILLOSCOPE.

PART NO:

DELTA MODEL: ASB0305HP-007HQ

LIFE EXPECTANCE (L10) (AT LABEL VOLTAGE)	50,000 HOURS CONTINUOUS OPERATION AT 40 ° C WITH 15 ~ 65 %RH.
ROTATION	CLOCKWISE VIEW FROM NAME PLATE SIDE
LOCKED PROTECTION	THE FAN WILL SHUT DOWN WHEN LOCKED ROTOR.

NOTES:

1. ALL READINGS ARE MEASURED AFTER STABLY WARMING UP THROUGH 10 MINUTES.
2. STANDARD AIR PROPERTY IS AIR AT (Td) 25°C TEMPERATURE, (RH) 65% RELATIVE HUMIDITY , AND (Pb) 760 mmHg BAROMETRIC PRESSURE.
3. THE VALUES WRITTEN IN PARENS , (/), ARE LIMITED SPEC.
4. ACOUSTICAL NOISE MEASURING CONDITION:

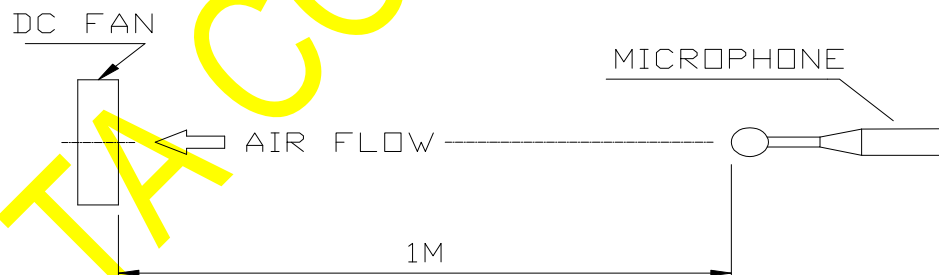

NOISE IS MEASURED AT RATED VOLTAGE IN FREE AIR IN ANECHOIC CHAMBER WITH B & K SOUND LEVEL METER WITH MICROPHONE AT A DISTANCE OF ONE METER FROM THE FAN INTAKE.

PART NO:

DELTA MODEL: ASB0305HP-007HQ

3. MECHANICAL:

- 3-1. DIMENSIONS----- SEE DIMENSIONS DRAWING
- 3-2. FRAME----- PLASTIC UL: 94V-0
- 3-3. IMPELLER----- PLASTIC UL: 94V-0
- 3-4. BEARING SYSTEM----- SUPERFLO BEARING
- 3-5. WEIGHT----- 4.5 GRAMS(REF.)

4. ENVIRONMENTAL:

- 4-1. OPERATING TEMPERATURE----- -10 TO +70 DEGREE C
- 4-2. STORAGE TEMPERATURE----- -40 TO +70 DEGREE C
- 4-3. OPERATING HUMIDITY----- 5 TO 90 % RH
- 4-4. STORAGE HUMIDITY----- 5 TO 95 % RH

5. PROTECTION:

- 5-1. LOCKED ROTOR PROTECTION
IMPEDANCE OF MOTOR WINDING PROTECTS MOTOR FROM FIRE IN
96 HOURS OF LOCKED ROTOR CONDITION AT THE RATED VOLTAGE.

6. RE OZONE DEPLETING SUBSTANCES:

- 6-1. NO CONTAINING PBBs, PBBOs, CFCs, PBBEs, PBDPEs AND HCFCs.

7. PRODUCTION LOCATION

- 7-1. PRODUCTS WILL BE PRODUCED IN CHINA OR THAILAND.

PART NO:

DELTA MODEL: ASB0305HP-007HQ

8. P & Q CURVE:

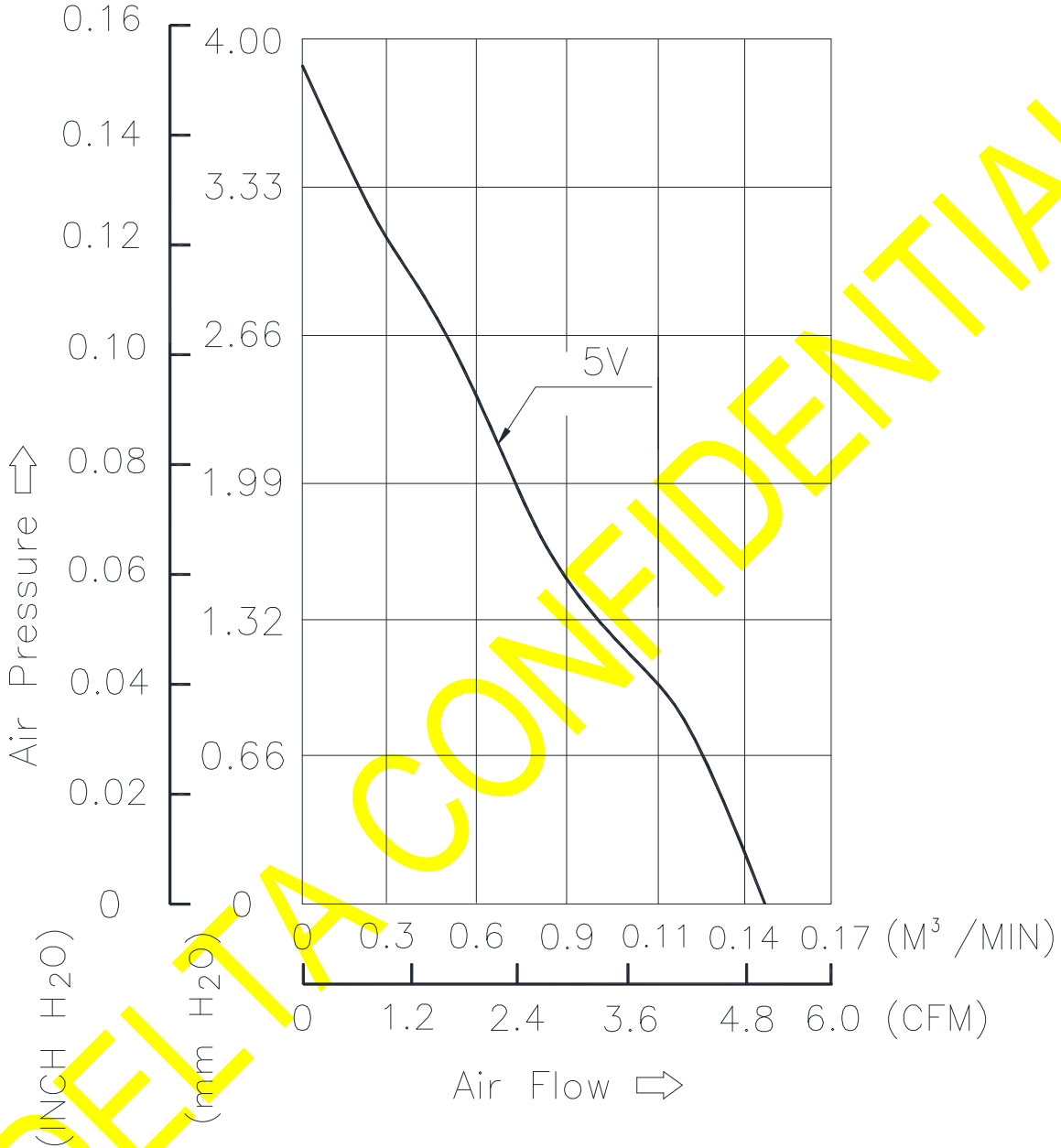

*TEST CONDITION: INPUT VOLTAGE-----OPERATION VOLTAGE
TEMPERATURE-----ROOM TEMPERATURE
HUMIDITY-----65%RH

PART NO:

DELTA MODEL: ASB0305HP-007HQ

9. DIMENSION DRAWING:

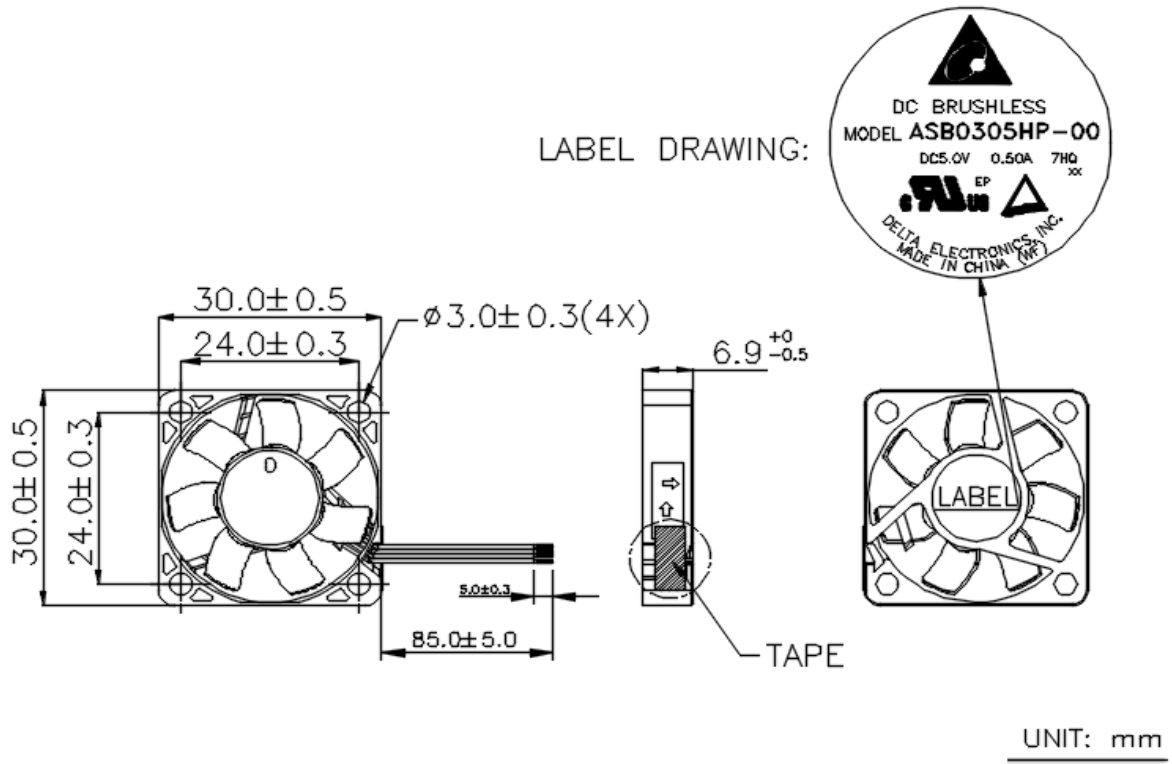

NOTES:

1. LEAD WIRE UL10064 AWG#32
RED WIRE-----(+)
BLACK WIRE-----(-)
YELLOW WIRE----- (F00)
BLUE WIRE----- (PWM)
2. THIS PRODUCT IS RoHS COMPLIANT
3. DELTA'S RESTRICTIONS ON HALOGEN APPLY ONLY TO BROMINATED AND CHLORINATED COMPOUNDS. NO OTHER HALOGEN IS RESTRICTED. SUBSTANCES RESTRICTIONS FOR HALOGEN-FREE(INCLUDE FAN PLASTIC PARTS, PWB BOARD, IC, ELECTRICAL MATERIALS & CABLE ASSY),
 - a. BROMINE(Br) < 900 PPM,
 - b. CHLORINE(Cl) < 900 PPM
 - c. (Br) + (Cl) < 1500 PPM.

PART NO:

DELTA MODEL: ASB0305HP-007HQ

10.FREQUENCY GENERATOR (FG) SIGNAL:

10-1. OUTPUT CIRCUIT - OPEN DRAIN MODE:

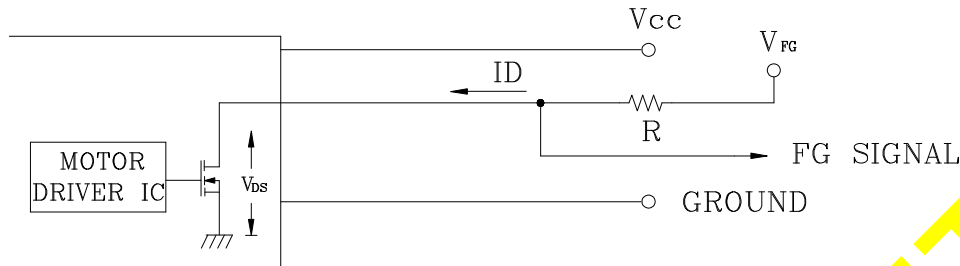

CAUTION:

THE FG SIGNAL LEAD WIRE MUST BE KEPT AWAY FROM "+" LEAD WIRE & "-" LEAD WIRE.

10-2. SPECIFICATION:

$V_{FG} = 5V$ TYP. (V_{CC} MAX.)

$I_D = 5mA$ MAX.

$$R \cong V_{FG} / I_D$$

THE RESISTOR R IS NOT INCLUDED IN FAN CIRCUIT AND NEEDS TO BE PROVIDED BY FAN USER

10-3. FREQUENCY GENERATOR WAVEFORM:

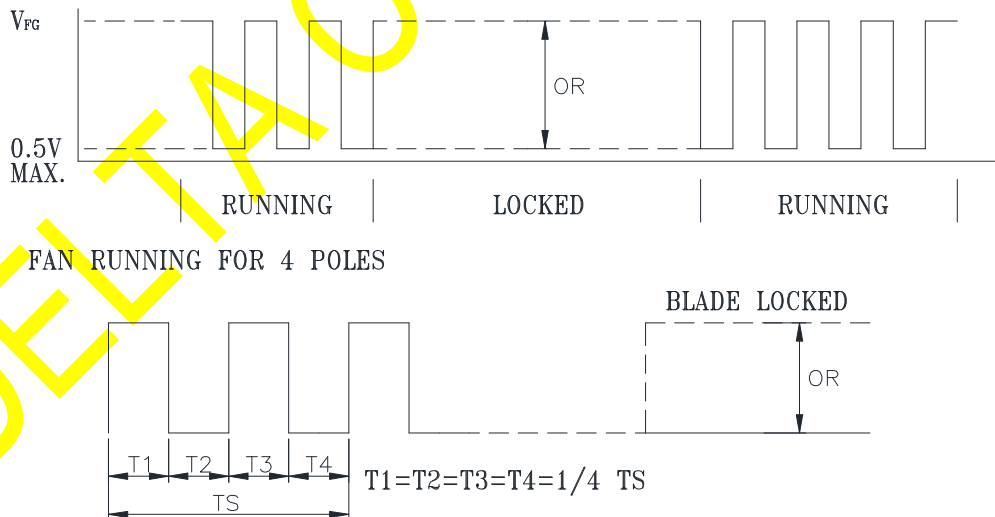

$N=R.P.M$

$TS=60/N(SEC)$

PART NO:

DELTA MODEL: ASB0305HP-007HQ

11. PWM CONTROL FUNCTION

11-1. PWM CONTROL INTERFACE

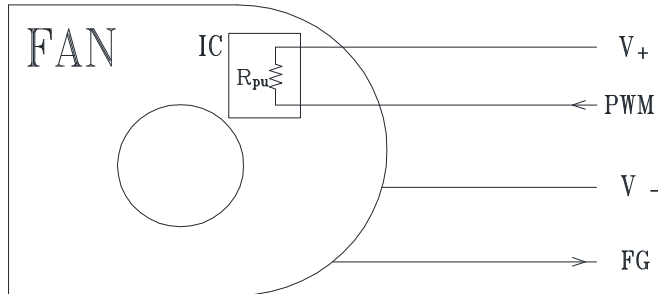

SIGNAL VOLTAGE RANGE: 0 ~ (V₊ - 0.5) VDC

----- HIGH LEVEL
----- LOW LEVEL

DUTY CYCLE = $\frac{t}{T} * 100(\%)$
Frequency = $\frac{1}{T}$

- HIGH LEVEL : (V₊ - 0.5) VDC max.
2.8 VDC min.
- LOW LEVEL : 0.6 VDC max.
0 VDC min.
- R_{pu} : 200Kohm ~ 500Kohm.

- THE R_{pu} IS A SEMICONDUCTING RESISTOR BUILD IN THE IC WAFER OF THE FAN DRIVER FOR THE DEFAULT SETTING.
- THE FREQUENCY FOR CONTROL SINGAL OF THE FAN SHALL BE ABLE TO ACCEPT A 20KHZ~50KHZ.
- THE PREFERRED OPERATING FREQUENCY OF PWM SIGNAL IS 25KHZ.
- AT 100% DUTY CYCLE, THE ROTOR WILL SPIN AT MAXIMUM SPEED.
- AT 0% DUTY CYCLE, THE ROTOR WILL STOP TO SPIN.
- DUE TO PULL UP RESISTER(R_{pu}), WHEN THE PWM CONTROL LEAD WIRE IS DISCONNECTED, THE ROTOR WILL SPIN AT MAXIMUM SPEED.

11-2. THE REQUIREMENT OF WAVEFORM QUALITY OF PWM SIGNAL

- THE RECOMMENDED PWM SIGNAL FROM SYSTEM IS TTL (t_r=50ns, t_f=50ns), EVEN IF THE PWM LEAD OF FAN IS DISCONNECTED.
- THE MAXIMUM PERMISSIBLE OF WAVEFORM DISTORTION:

V_{IH} : (V₊ - 0.5) × 90% RISE TIME : t_r<500ns
V_{IL} : (V₊ - 0.5) × 10% FALL TIME : t_f<500ns

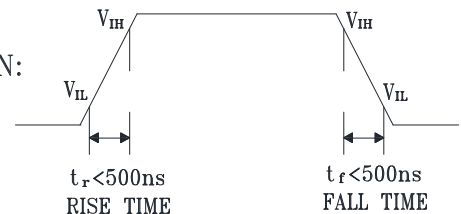

11-3. FAN CHARACTERISTICS

TEST CONDITION : AT 25°C, V⁺ = 5.0VDC & PWM SIGNAL AS FOLLOW

* PWM SIGNAL
PWM FREQUENCY = 25 KHz

DUTY CYCLE (%)	SPEED R.P.M.	CURRENT (A) TYP.
100	9500±15%(REF)	0.2(A) (REF)
0	0	0.2(mA)



- MIN. STARTED DUTY CYCLE : 30%
WHEN DUTY CYCLE IS SET FOR MORE THAN 30% , THE FAN WILL BE ABLE TO START FROM A DEAD STOP.

PART NO:

DELTA MODEL: ASB0305HP-007HQ

12. TYPICAL STARTUP SEQUENCE (CONDITION: 25°C, 5.0VDC, 1 ATM)

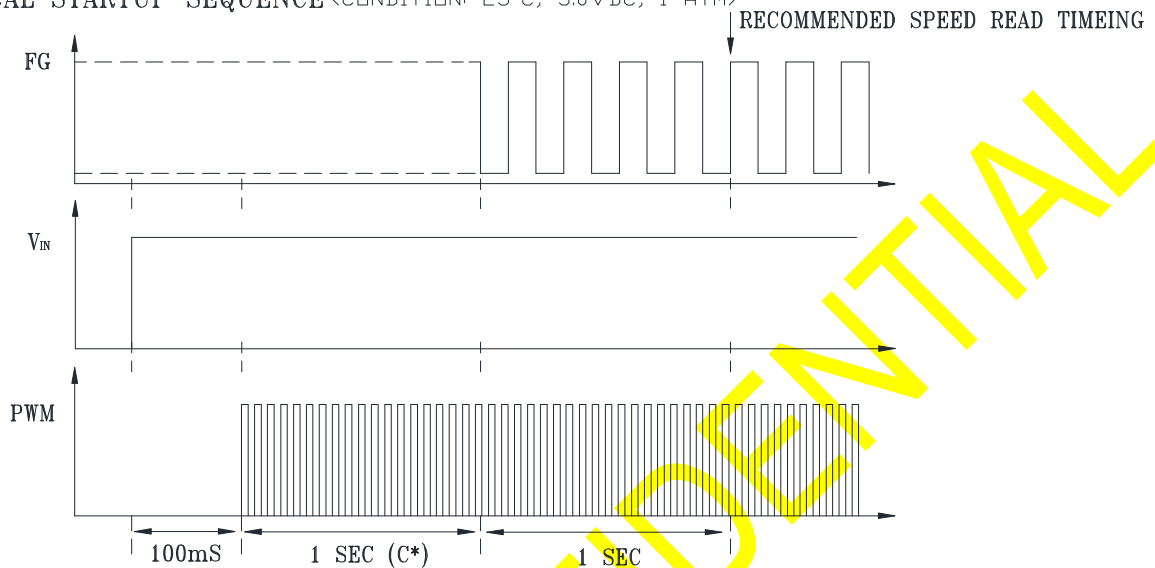

- THE FIRST 100mS IS USED TO WAIT FOR VCC SETTling.
- THE PWM SIGNAL CAN NOT INPUT BEFORE VCC.

13. DEFINITION OF LOCK DETECTION, LOCK-OFF TIME, AND QUICK START FUNCTION

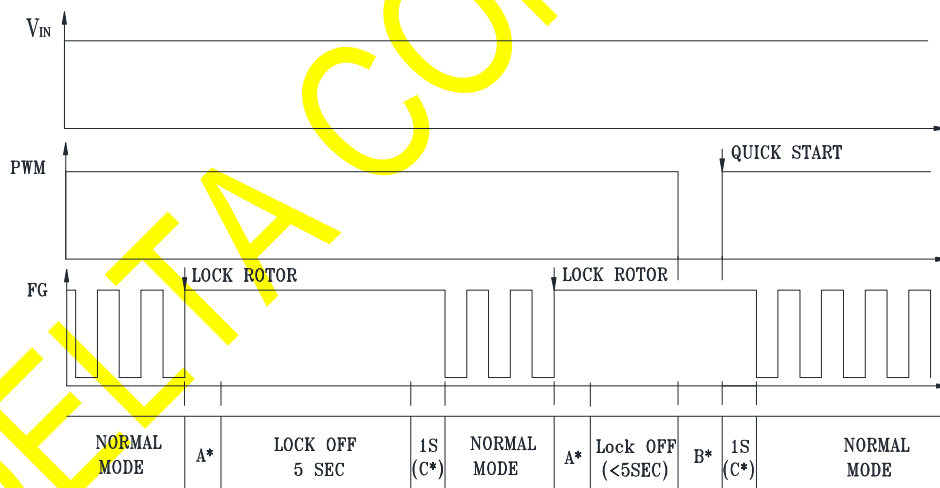

A* : TYPICALLY 0.5 SEC FOR LOCK DETECTION.

B* : COMMONLY 100mS DETECTION TIME FOR LOCK-OFF RELEASE.

C* : FG OUTPUT DELAY TIME.

- THE 5SEC LOCK-OFF TIME IS ALSO A TYPICAL VALUE AND THE MAXIMUM TOLERANCE IS 10 SECONDS.



Application Notice

- 1. Delta will not guarantee the performance of the products if the application condition falls outside the parameters set forth in the specification.**
- 2. A written request should be submitted to Delta prior to approval if deviation from this specification is required.**
- 3. Please exercise caution when handling fans. Damage may be caused when pressure is applied to the impeller, if the fans are handled by the lead wires, or if the fan was hard-dropped to the production floor.**
- 4. Except as pertains to some special designs, there is no guarantee that the products will be free from any such safety problems or failures as caused by the introduction of powder, droplets of water or encroachment of insect into the hub.**
- 5. The above-mentioned conditions are representative of some unique examples and viewed as the first point of reference prior to all other information.**
- 6. It is very important to establish the correct polarity before connecting the fan to the power source. Positive (+) and Negative (-). Damage may be caused to the fans if connection is with reverse polarity, if there is no foolproof method to protect against such error specifically mentioned in this spec.**
- 7. Delta fans without special protection are not suitable where any corrosive fluids are introduced to their environment.**
- 8. Please ensure all fans are stored according to the storage temperature limits specified. Do not store fans in a high humidity environment. We highly recommend performance testing is conducted before shipping, if the fans have been stored over 6 months.**
- 9. Not all fans are provided with the Lock Rotor Protection feature. If you impair the rotation of the impeller for the fans that do not have this function, the performance of those fans will lead to failure.**
- 10. Please be cautious when mounting the fan. Incorrect mounting of fans may cause excess resonance, vibration and subsequent noise.**
- 11. It is important to consider safety when testing the fans. A suitable fan guard should be fitted to the fan to guard against any potential for personal injury.**
- 12. Except where specifically stated, all tests are carried out at room (ambient) temperature and relative humidity conditions of 25°C, 65% RH. The test value is only for fan performance itself.**
- 13. Be certain to connect an “ 4.7μF or greater” capacitor to the fan externally when the application calls for using multiple fans in parallel, to avoid any unstable power.**

File E132003
Project 11CA28112

June 15, 2011

REPORT

ON

COMPONENT - FANS, ELECTRIC

Delta Electronics Inc.
Taoyuan, Taiwan

Copyright © 2011 Underwriters Laboratories Inc.

Underwriters Laboratories Inc. authorizes the above named company to reproduce this Report provided it is reproduced in its entirety.

Underwriters Laboratories Inc. authorizes the above-named company to reproduce the latest pages of that portion of this Report consisting of this Cover Page through Page 3.

DESCRIPTION

PRODUCT COVERED:

USR, CNR Component - DC Fans, Models see "ELECTRICAL RATINGS" for details.

USR indicates investigation to the Standard for Electric Fans, UL 507.

CNR indicates investigation to the Canadian Standard for Fans and Ventilators, CSA C22.2 No. 113-10.

ELECTRICAL RATINGS:

Model Nos.	Volts, dc	Amperes, A
BFB1012UH-BA40 (Y)	14.2	3.15
BFB1012VH-7J56 (Y)	12	2.7

Note: Above (Y) may be xxxxx, where x may be A through Z, 0 through 9, "-" or blank.

Model Nos.	Volts, dc	Amperes, A
BFB1012HN (Y9)	12-14	0.38
BFB1012MN (Y9)	12-14	0.24
BFB1212VHA01 (Y6)	12	0.6
BUB0612HJ-00 (Y6)	12	0.8
BUB0612MJ-00 (Y6)	12	0.35
ASB0305HP-00 (Y6)	5	0.5
BUC1512HF-00 (Y6)	12	1.6

Note:

1. Models BFB1012HN(Y9) and BFB1012MN(Y9) series may be marked with variety rated Volt between 12-14V.
2. The number after Y represents digit, each digit may be A through Z, 0 through 9, "-" or blank.

8. The Temperature Test conducted on the fans described in this Report was done in an average ambient temperature of 25°C. The suitability of the fan when they are intended to operate in a higher ambient temperature shall be evaluated during the end-use investigation.
9. These fans shall be mounted and enclosed in accordance with the frame and enclosure requirements of the end product. Suitable enclosures or guards shall be provided for the fan blades to reduce the risk of injury to persons. The fans may be provided with a finger guard. Suitability of the finger guard shall be determined in the end-use investigation.
10. The minimum flammability rating of the plastic used for the fan frame, and impeller of the fans described in this Report is V-0.
11. The minimum flammability rating of the bobbin and other insulating material of the fans described in this Report is V-0 at 1.6 mm (or 1.5 mm) thick.
12. These fans described in this Report have not been evaluated to the requirements for over-surface and through-air spacings described in Section 24 of the Standard for Electric Fans, UL 507 and Clause 9.3 of the Canadian Standard for Fans and Ventilators, CSA C22.2 No. 113-10. These spacings have been waived on the basis that these fans will be connected to an isolated secondary circuit rated maximum 30 V rms (42.2 V peak) or 60 V dc and are subjected to a 500 V dielectric strength test.
13. The minimum flammability rating of the printed wiring boards used in the fans described in this Report is V-0.
14. These fans described in this report may be mounted to an external heatsink, mounting bracket, chassis, shroud, or the like. The above mounted parts have not been evaluated with the fans. Suitability of the above parts shall be evaluated in combination with the fan during the end-product investigation and described in the end-product report.
15. The suitability of the lead terminations and connectors shall be determined during the end-product investigation.
16. Wiring leads are tack soldered to the printed wiring board. Suitability of the lead securement and routing shall be evaluated in the end product.
17. These Models BFB1012UH-BA40(Y), BFB1012VH-7J56(Y), BFB1012HN(Y9), **BFB1012MN(Y9)**, **BFB1212VHA01(Y6)** series are provided with an external lead that is intended for connection to an external speed control (PWM) circuit. There is no external lead provided to connected during the component fan investigation. Suitability of the leads shall be determined in the end-product.
18. Models BFB1012HN(Y9) and BFB1012MN(Y9) series may be marked with variety rated volts between 12-14V. Suitability for actual current shall be evaluated in the end-use product.

Zertifikat Certificate



Zertifikat Nr. *Certificate No.*
R 50156481

Blatt *Page*
0203

Ihr Zeichen *Client Reference*
SF170322C

Unser Zeichen *Our Reference*
ZTW1-YML- 11016900 172

Ausstellungsdatum
02.05.2017

Date of Issue
(day/mo/yr)

Genehmigungsinhaber *License Holder*
Delta Electronics, Inc.
252, Shangying Road,
Guishan Industrial Zone,
Taoyuan City 33341
Taiwan, R.O.C.

Fertigungsstätte *Manufacturing Plant*
Delta Electronics (Jiangsu) Ltd.
No. 1688, Jiangxing East Road
Wujiang Economic Development Zone
Wujiang City, Jiangsu Province 215200
P.R. China

Prüfzeichen *Test Mark*



Geprüft nach *Tested acc. to*

IEC 60950-1:2005+A1+A2
EN 60950-1:2006+A11+A1+A12+A2

Zertifiziertes Produkt (Geräteidentifikation)
Certified Product (Product Identification)

Lizenzentgelte - Einheit
License Fee - Unit

Ventilator (DC Brushless Fan)

wie Blatt (as page) 01, Ergänzung (Addition)

Bezeichnung (Type Designation) : ASB0305HP-00XXXXXX 1
X steht für (stands for) : A-Z, 0-9, - oder (or) freibleibend (blank) 1
Nur zum Zwecke der Vermarktung. (for marketing purpose only)
Nennspannung (Rated Voltage) : DC 5V
Nennstrom (Rated Current) : 0.5A
Max. Umgebungstemperatur (Max. Ambient Temperature) : 70°C

Vermerke: Dieses Netzgerät ist auch geprüft und klassifiziert als Abschnitt 4.4.5.1 a.
(Remark: The equipment is also tested and classified as sub-clause 4.4.5.1 a.)

2

ANLAGE (Appendix): 3.52

Dem Zertifikat liegt unsere Prüf- und Zertifizierungsordnung zugrunde und es bestätigt die Konformität des Produktes mit den oben genannten Standards und Prüfgrundlagen. Zusätzliche Anforderungen in Ländern, in denen das Produkt in Verkehr gebracht werden soll, müssen zusätzlich betrachtet werden. Die Herstellung des zertifizierten Produktes wird überwacht.
This certificate is based on our Testing and Certification Regulation and states the conformity of the product with the standards and testing requirements as indicated above. Any additional requirements in countries where the product is going to be marketed have to be considered additionally. The manufacturing of the certified product is subject to surveillance.

TÜV Rheinland LGA Products GmbH - Tillystraße 2 - 90431 Nürnberg
Tel.: (+49/221)8 06 - 13 71 e-mail: cert-validity@de.tuv.com
Fax: (+49/221)8 06 - 39 35 http://www.tuv.com/safety

