

1. Description

These devices are well suited for low voltage and battery powered applications where low in-line power loss is needed in a very small outline surface mount package.

3. Application

- Notebook computer power management

2. Features

- $V_{DS(V)} = -30V$
- $I_D = -1.3A$
- $R_{DS(ON)}(V_{GS} = -10V) \leq 150m\Omega$
- $R_{DS(ON)}(V_{GS} = -4.5V) \leq 250m\Omega$

4. Pinning information

Pin	Symbol	Description
1	G	GATE
2	S	SOURCE
3	D	DRAIN

SOT-23

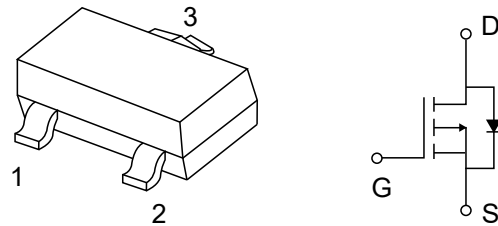

5. Maximum ratings ($T_A = 25^\circ C$ unless otherwise noted)

Parameter	Symbol	Value	Units
Drain-Source Voltage	V_{DSS}	-30	V
Gate-Source Voltage	V_{GSS}	± 25	V
Drain Current – Continuous (Note 1a) – Pulsed	I_D	-1.3	A
		-10	
Maximum Power Dissipation (Note 1a) (Note 1b)	P_D	0.5	W
		0.46	
Operating and Storage Junction Temperature Range	T_J, T_{STG}	-55 to 150	$^\circ C$
Thermal Characteristics			
Thermal Resistance, Junction-to-Ambient (Note 1a)	$R_{\theta JA}$	250	$^\circ C/W$
Thermal Resistance, Junction-to-Case (Note 1)	$R_{\theta JC}$	75	$^\circ C/W$



6. $T_A=25^\circ\text{C}$ unless otherwise specified

Parameter	Symbol	Conditions	Min	Typ	Max	Units
Off Characteristics						
Drain-Source Breakdown Voltage	BV_{DSS}	$I_D=-250\mu\text{A}$, $V_{GS}=0\text{V}$	-30			V
Breakdown Voltage Temperature Coefficient	$\frac{\Delta BV_{DSS}}{\Delta T_J}$	$I_D=-250\mu\text{A}$ Referenced to 25°C		-17		mV/ $^\circ\text{C}$
Zero Gate Voltage Drain Current	I_{DSS}	$V_{DS}=-24\text{V}$, $V_{GS}=0\text{V}$			-1	μA
Gate-Body Leakage	I_{GSS}	$V_{GS}=\pm 25\text{V}$, $V_{DS}=0\text{V}$			± 100	nA
On Characteristics (Note 2)						
Gate Threshold Voltage	$V_{GS(th)}$	$V_{DS}=V_{GS}$, $I_D=-250\mu\text{A}$	-0.8	-2	-2.5	V
Gate Threshold Voltage Temperature Coefficient	$\frac{\Delta V_{GS(th)}}{\Delta T_J}$	$I_D=-250\mu\text{A}$ Referenced to 25°C		4		mV/ $^\circ\text{C}$
Static Drain-Source On-Resistance	$R_{DS(ON)}$	$V_{GS}=-10\text{V}$, $I_D=-1.3\text{A}$ $V_{GS}=-4.5\text{V}$, $I_D=-1.1\text{A}$		120 150	150 250	m Ω m Ω
Forward Transconductance	g_{FS}	$V_{DS}=-5\text{V}$, $I_D=-0.9\text{A}$		2		S
Dynamic Characteristics						
Input Capacitance	C_{iss}	$V_{DS}=-15\text{V}$, $V_{GS}=0\text{V}$, $f=1\text{MHz}$		150		pF
Output Capacitance	C_{oss}			40		pF
Reverse Transfer Capacitance	C_{rss}			20		pF
SWITCHING PARAMETERS (Note 2)						
Turn-On Delay Time	$t_{D(on)}$	$V_{DD}=-10\text{V}$, $I_D=-1\text{A}$ $V_{GS}=-10\text{V}$, $R_{GEN}=6\Omega$		4	8	ns
Turn-On Rise Time	t_r			15	28	ns
Turn-Off Delay Time	$t_{D(off)}$			10	18	ns
Turn-Off Fall Time	t_f			1	2	ns
Total Gate Charge	Q_g	$V_{DS}=-10\text{V}$, $I_D=-0.9\text{A}$ $V_{GS}=-4.5\text{V}$		1.4	1.9	nC
Gate-Source Charge	Q_{gs}			0.5		nC
Gate-Drain Charge	Q_{gd}			0.5		nC



Drain–Source Diode Characteristics and Maximum Ratings						
Maximum Continuous Drain–Source Diode Forward Current	I_S				-0.42	A
Drain–Source Diode Forward Voltage	V_{SD}	$V_{GS}=0V, I_S=-0.42A$ (Note 2)		-0.8	-1.2	V
Diode Reverse Recovery Time	t_{rr}	$I_F=-3.9A$		17		ns
Diode Reverse Recovery Charge	Q_{rr}	$dI_F/dt=100A/\mu s$		7		nC

1. $R_{\theta JA}$ is the sum of the junction-to-case and case-to-ambient thermal resistance where the case thermal reference is defined as the solder mounting surface of the drain pins. $R_{\theta JC}$ is guaranteed by design while $R_{\theta JA}$ is determined by the user's board design.

(a) $R_{\theta JA} = 250^{\circ}C/W$ when mounted on a 0.02 in^2 pad of 2oz. copper.

(b) $R_{\theta JA} = 270^{\circ}C/W$ when mounted on a 0.001 in^2 pad of 2oz. copper.

2. Pulse Test: Pulse Width < $300\mu s$, Duty Cycle < 2.0%



7.1 Typical Characteristics

<p>Figure 1: On-Region Characteristics.</p>	<p>Figure 2: On-Resistance Variation with Drain Current and Gate Voltage.</p>
<p>Figure 3: On-Resistance Variation with Temperature.</p>	<p>Figure 4: On-Resistance Variation with Gate-to-Source Voltage.</p>
<p>Figure 5: Transfer Characteristics.</p>	<p>Figure 6: . Body Diode Forward Voltage Variation with Source Current and Temperature.</p>



7.2 Typical Characteristics

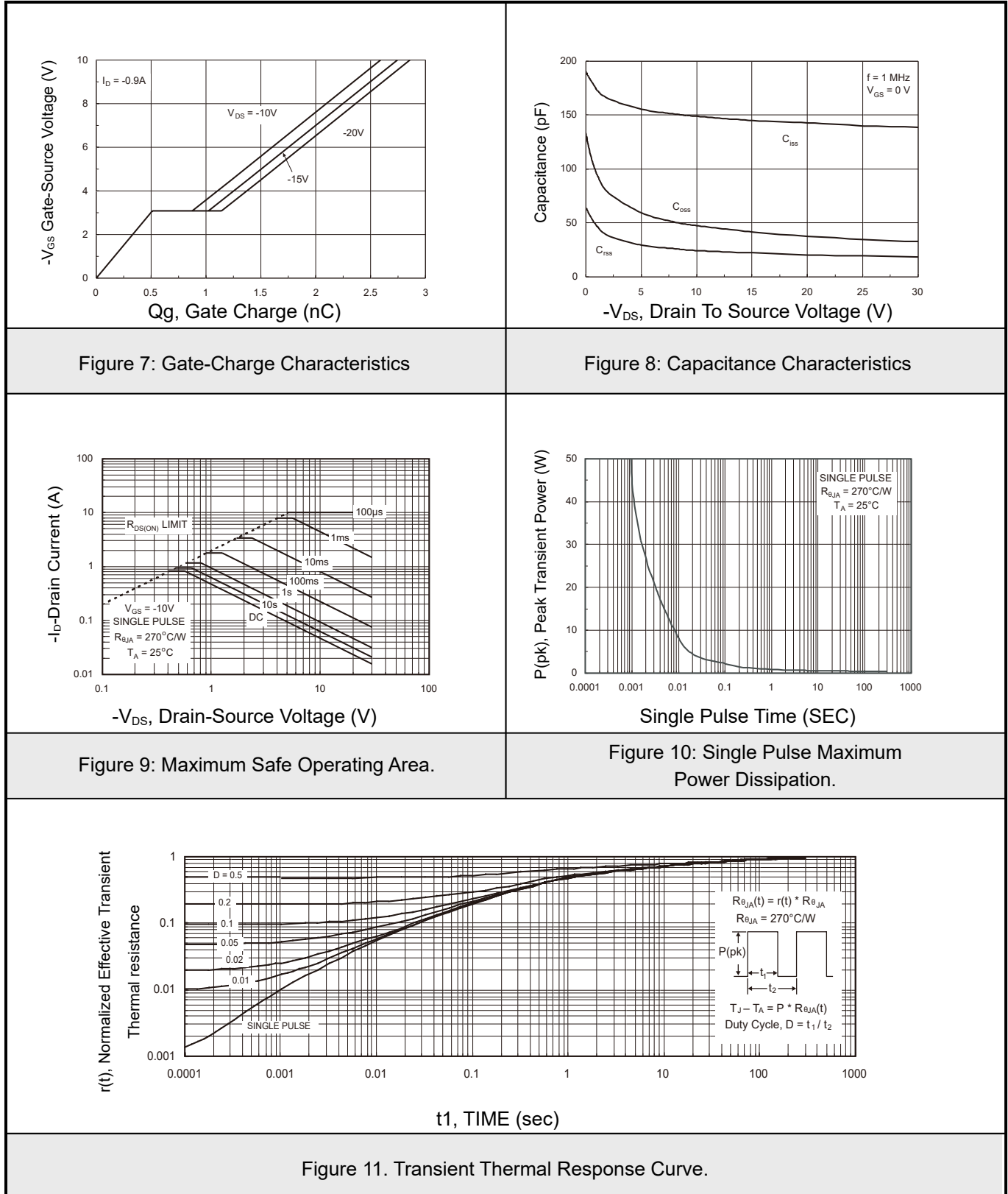



8.SOT-23 Package Outline Dimensions

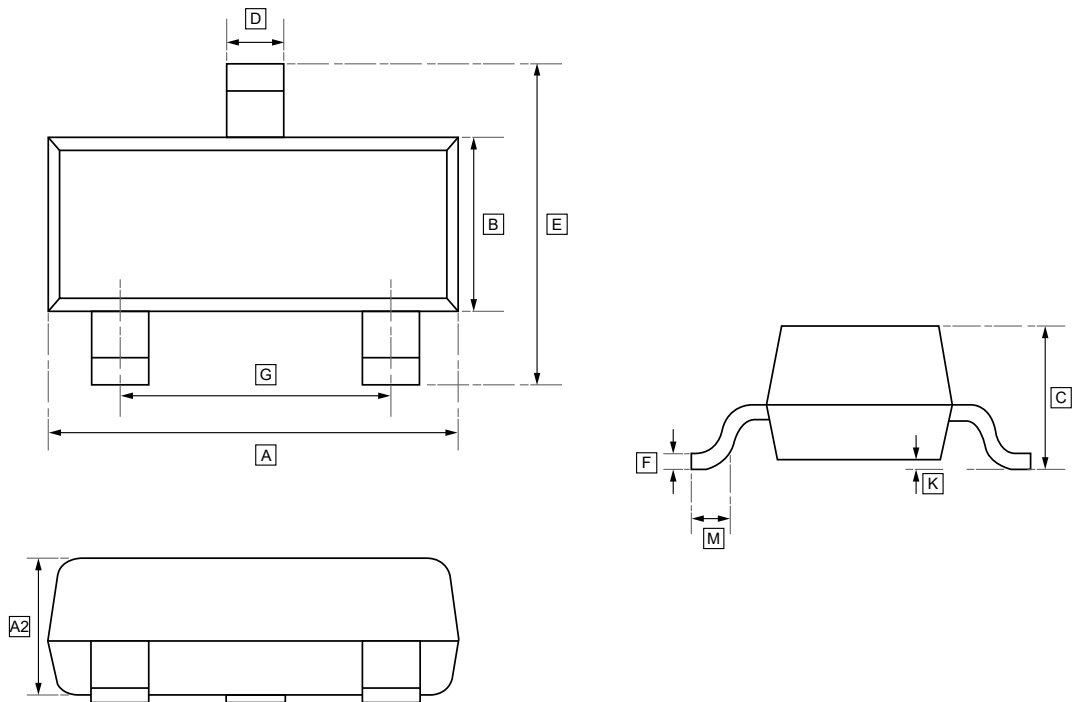

DIMENSIONS (mm are the original dimensions)

Symbol	A	B	C	D	E	G	K	M	A2	F
Min	2.85	1.20	0.90	0.40	2.25	1.80	0.00	0.30	0.95	0.095
Max	3.04	1.40	1.10	0.50	2.55	2.00	0.10	-	1.05	0.115



9. Ordering Information

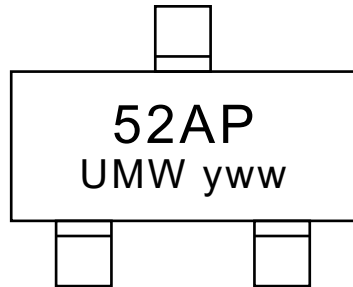

yww: Batch Code

Order Code	Package	Base QTY	Delivery Mode
UMW FDN352AP	SOT-23	3000	Tape and reel



10.Disclaimer

UMW reserves the right to make changes to all products, specifications. Customers should obtain the latest version of product documentation and verify the completeness and currency of the information before placing an order.

When applying our products, please do not exceed the maximum rated values, as this may affect the reliability of the entire system. Under certain conditions, any semiconductor product may experience faults or failures. Buyers are responsible for adhering to safety standards and implementing safety measures during system design, prototyping, and manufacturing when using our products to prevent potential failure risks that could lead to personal injury or property damage.

Unless explicitly stated in writing, UMW products are not intended for use in medical, life-saving, or life-sustaining applications, nor for any other applications where product failure could result in personal injury or death. If customers use or sell the product for such applications without explicit authorization, they assume all associated risks.

When reselling, applying, or exporting, please comply with export control laws and regulations of China, the United States, the United Kingdom, the European Union, and other relevant countries, regions, and international organizations.

This document and any actions by UMW do not grant any intellectual property rights, whether express or implied, by estoppel or otherwise. The product names and marks mentioned herein may be trademarks of their respective owners.