

LLCC68SXXXN0SA wireless module

Hardware Specifications

V1.0

Content

1. Overview	1
2. Electrical Characteristics	3
3. Pin Diagram	4
4.Pin Description	5
5. Hardware design guide	6
5.1. Application circuit	6
5.2. Power supply design	6
5.3 . Antenna design and guidance	7
6. Programming development	10
7.Reflow Profile	12
8. ESD Notice	12
9. Packaging information	13
Mechanical size (unit:mm)	13
10. Revision History	14
11. Ordering Information	14
12. Statement	14
13. Contact us	15

1. Overview

LLCC68SXXXN0SA series wireless module, based on SEMTECH's LLCC68 high-performance wireless transceiver chip design, is a compact, low-power, long-distance two-way wireless transceiver module. The module adopts a high-precision active temperature-compensated crystal oscillator, which has better temperature stability than ordinary passive crystal oscillator modules, and the operating frequency offset is almost not affected by changes in ambient temperature, which makes the module complex and harsh. The best choice for wireless solutions in industrial environments.

The LLCC68 sub - GHz wireless transceiver is ideal for long-range wireless applications. The LLCC68 has a built-in high-efficiency power amplifier up to +22 dBm ; the module can support LoRa modulation for LPWAN use cases and (G)FSK modulation for traditional use cases, with highly configurable parameters to meet different application requirements for industrial and consumer use. The LoRa® modulation method is compatible with the technical specifications published by the LoRa Alliance. This wireless module is suitable for systems that comply with radio regulations, including but not limited to ETSI EN 300 220, FCC CFR 47 Part 15, Chinese regulatory requirements and Japan ARIB T-108. The wireless transceiver supports continuous frequency coverage from 150 MHz to 960 MHz, allowing it to support all major sub - GHz ISM bands worldwide.

The module integrates all RF-related functions and devices. Users can use this module to easily develop wireless solutions and wireless IoT devices with stable performance and high reliability without in-depth understanding of RF circuit design.

Features:

- Supports LoRa and FSK modems
- Active temperature compensated crystal oscillator
- Up to +22 dBm output power
- Low RX current less than 6 mA
- Integrated DC-DC converter and LDO two power supply modes
- LORA mode is programmable from 1.76 kbps to 62.5 kbps
- High receive sensitivity: as low as -129 dB

Application:

- Smart meter reading
- Supply Chain and Logistics
- building automation
- agricultural sensor
- Smart City
- retail store sensor
- Asset tracking
- street light
- parking sensor
- environmental sensor
- medical insurance
- Safety and Security Sensors
- Remote control application

2. Electrical Characteristics

Parameter	Description	Remark
Power Supply	1.8 ~ 3.7V	Typically 3.3V
Frequency Bands	170MHz / 433MHz / 490MHz / 868MHz / 915MHz _	The applicable frequency band is determined by the specific hardware module
Output Power	- 3dBm to + 22dBm	Step value 1 dBm
Data Rate	0.6kbps ~ 300Kbps@FSK 1.76kbps ~ 62.5kbps@LoRa _	Programmable configuration
RF Modulation	LORA, (G) FSK	Recommend LORA
Crystal frequency	32MHz _	Active temperature compensated crystal oscillator
Receive sensitivity	-12 9 dBm	LORA modulation , BW=250K, SF=10
receive bandwidth	4.8kHz ~ 467kHz/FSK 125kHz , 250kHz , 500kHz / LoRa ____	Programmable configuration
TX Current	118mA	Transmit Power = + 22dBm
RX Current	6mA _	DC-DC mode
sleep Current	<1uA	
driver interface	SPI	Standard 4-wire SPI, SPI clock: < =10MHz CPOL = 0, CPHA = 0
Antenna impedance	50 ohms	
Antenna connection method	stamp hole	
storage temperature	-55°C ~ + 125°C	
Operating temperature	-40°C ~ + 85°C	Industrial grade

Size	11.5x11.5mm	
------	-------------	--

3. Pin Diagram

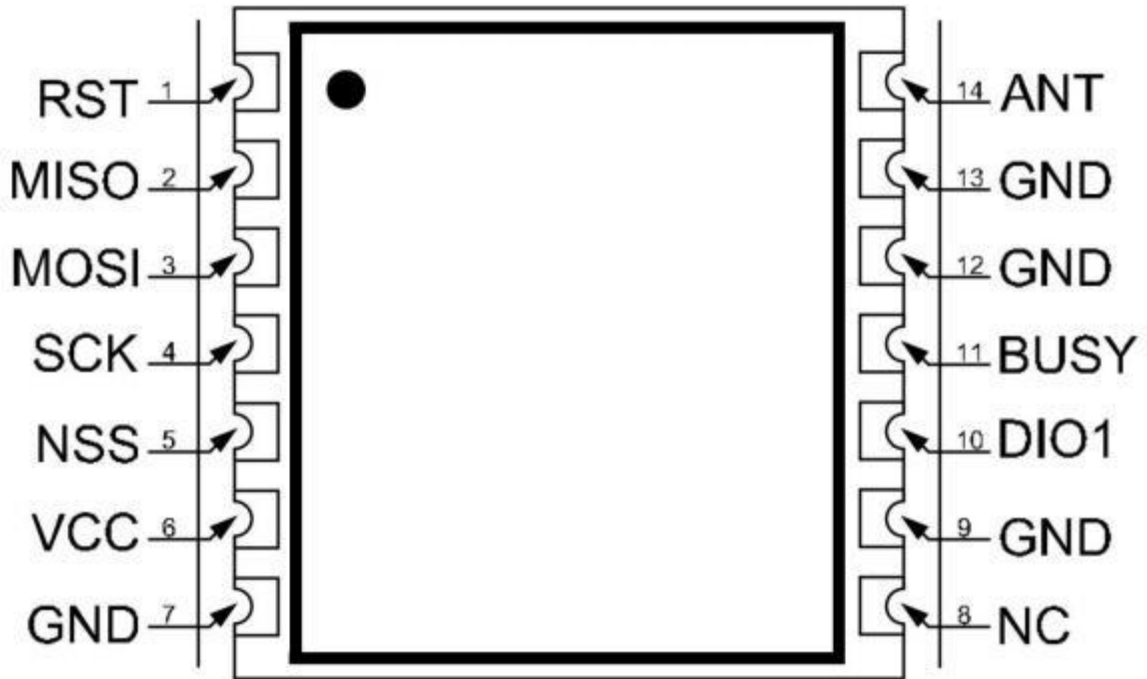

Figure 1-1 Top view

4. Pin Description

Number	Name	Type	Description
1	RST	I	Reset signal, active low
2	MISO	O	SPI interface MISO data output
3	MOSI	I	SPI interface MOSI data input
4	SCK	I	SPI interface SCLK clock input
5	NSS	I	SPI interface SPI chip select
6	VCC	power supply	Positive power supply
7	GND	power supply	land
8	NC	--	The module is left floating
9	GND	power supply	land
10	DIO1	I/O	Directly connected to the chip DIO1 digital I/O pin, software configurable function
11	BUSY	O	Chip working status indication, busy status
12	GND	power supply	land
13	GND	power supply	land
14	ANT	I/O	RF signal input/output, connect to 50Ω antenna

...	DIO2	I/O	Directly connect the internal antenna switch of the module, call <code>SetDio2AsRfSwitchCtrl(...)</code> to set
...	DIO3	I/O	The module is internally connected to the active crystal oscillator power pin, and the <code>SX126xSetDio3AsTcxoCtrl(...)</code> is called to set

5. Hardware design guide

5.1. Application circuit

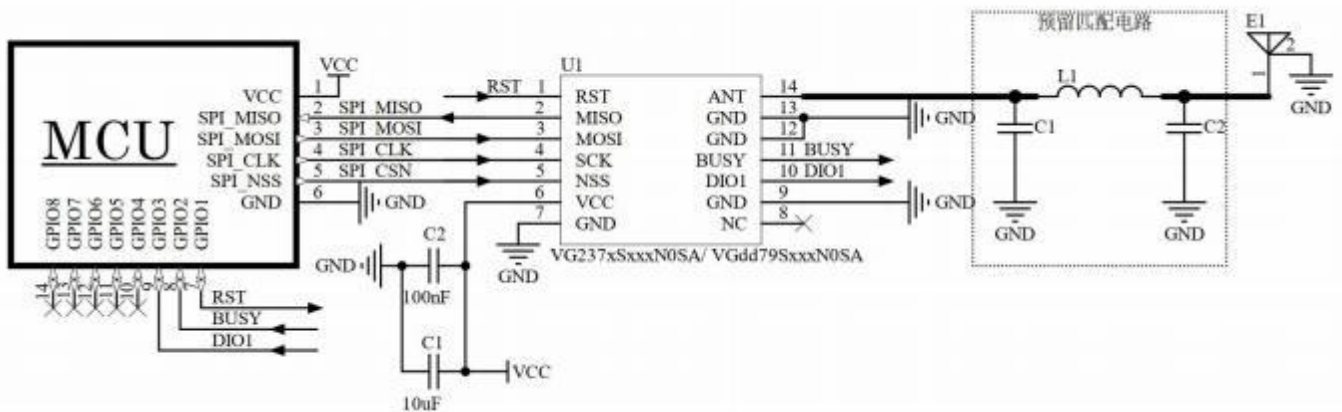

Figure 5-1 Programming development hardware connection

5.2. Power supply design

1. Please pay attention to the correct connection of the positive and negative poles of the power supply, and ensure that the power supply voltage is within the recommended power supply voltage range. If it exceeds the maximum allowable power supply range of the module, the module will be permanently damaged; the filter capacitor of the module power supply pin should be as close as possible to the module power supply pin.

2. In the power supply system of the module, the excessive ripple may be coupled to the line that is easily interfered by the wire or the ground plane, such as the sensitive signal line such as the antenna, feeder, clock line, etc., which may easily cause the radio frequency performance of the module to deteriorate, so We recommend using LDO as the power supply for the wireless module.

3. When selecting the LDO voltage regulator chip, it is necessary to pay attention to the heat dissipation of the power supply and the driving capability of the LDO stable output current; considering the long-term stable operation of the whole machine, it is recommended to reserve more than 50% of the current output margin.

4. It is best to use a single LDO for the module to supply power; if a DC-DC power supply chip is used, an

LDO must be added behind as the isolation of the module power supply to prevent the noise of the switching power supply chip from interfering with the working performance of the radio frequency.

5. If the communication line between the MCU and the module uses a 5V level, a 1K-5.1K resistor must be connected in series (not recommended, there is still a risk of damage) .



6. The RF module should be kept away from high-voltage devices as far as possible, because the electromagnetic waves of high-voltage devices will also have a certain impact on the RF signal.

7. High-frequency digital wiring, high-frequency analog wiring, and high-current power supply wiring should be avoided under the module as much as possible. If it is necessary to pass under the module, the wiring should be placed on another layer of the PCB bottom plate where the module is placed, and ensure that the module is under the module. The copper is well grounded.

5.3 . Antenna design and guidance

5.3.1 RF Design of Stamp Hole Interface

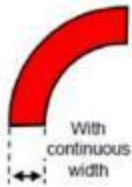
the RF output interface of the module is selected in the form of a stamp hole , a 50ohm characteristic impedance trace is used to connect the antenna on the backplane PCB during design. Considering the attenuation of high-frequency signals, it should be noted that the length of the RF traces on the backplane PCB should be as short as possible. It is recommended that the longest trace length should not exceed 20 mm , and the trace width should be kept continuous. When turning, try not to take acute or right angles. , it is recommended to take a circular arc.

<p>The first recommended way of turning the RF traces</p>	
<p>Second, the recommended way of turning the RF traces</p>	

<p>Bad way of turning RF traces , not recommended</p>	

In order to ensure that the RF trace impedance of the backplane is 50 ohms, the following parameters can be adjusted according to different board thicknesses. The following simulation values are for reference only.

<p>RF traces use 20mil line width</p>	<p>thickness is 1.0mm , the spacing between ground copper and traces is 5.3mil</p>
	<p>thickness is 1.2mm , the spacing between ground copper and traces is 5.1mil</p>
	<p>the board thickness is 1.6mm , the distance between ground copper and trace is 5mil</p>
<p>RF traces use 25mil line width</p>	<p>thickness is 1.0mm , the distance between ground copper and trace is 6.3mil</p>
	<p>the board thickness is 1.2mm , the distance between ground copper and trace is 6mil</p>
	<p>thickness is 1.6mm , the distance between ground copper and trace is 5.7mil</p>
<p>RF traces use 30mil line width</p>	<p>thickness is 1.0mm , the distance between ground copper and trace is 7.6mil</p>
	<p>thickness is 1.2mm , the distance between ground copper and trace is 7.1mil</p>
	<p>thickness is 1.6mm , the distance between ground copper and trace is 6.6mil</p>

5.3.2 Internal Antenna

The built-in antenna refers to the antenna soldered on the PCB bottom plate and placed inside the product shell, including chip ceramic antenna, spring antenna, etc. When using the built-in antenna, the structure of the product and the installation position of the antenna have a great influence on the RF performance. Under the premise that the structure space of the product shell is sufficient, the spring antenna should be placed vertically upward as much as possible; Or the circuit board below the antenna can be hollowed out, because the metal has a very strong ability to absorb and shield RF signals, which will seriously affect the communication distance. In addition, the antenna should be placed on the edge of the bottom plate as much as possible.

5.3.3 External Antenna

External antenna refers to the antenna that the module is installed on the outside of the product casing through IPEX extension cable, SMA and other standard RF interfaces, including rod antenna, suction cup antenna, fiberglass antenna, etc. The external antenna is basically a standard product. In order to better choose an antenna suitable for the module, in the process of antenna selection, the parameters of the antenna should be selected as follows:

1. The working frequency of the antenna should be consistent with the working frequency of the corresponding module.
2. The input characteristic impedance of the antenna should be 50ohm.
3. The interface size of the antenna should match the size of the antenna interface of the module.
4. The standing wave ratio (VSWR) of the antenna is recommended to be less than 2, and the antenna should have a suitable frequency bandwidth (covering the frequency points used in the actual application of specific products) .

5.3.4 Antenna matching

The antenna is critical to the transmission distance of the RF module. In practical applications, in order to facilitate the user's later antenna matching adjustment. It is recommended that users reserve a simple

π -type matching circuit between the antenna and the ANT pin output of the module when designing the schematic diagram. If the antenna is already a standard 50Ω , the component L1 is attached with a 0R resistor, and the components C1 and C2 do not need to be soldered. Otherwise, you need to use a network analyzer to measure the actual impedance of the antenna and perform matching to determine the values of C1, L1, and C2. The trace from the ANT pin of the module to the antenna end should be as short as possible. It is recommended that the longest trace length should not exceed 20 mm .

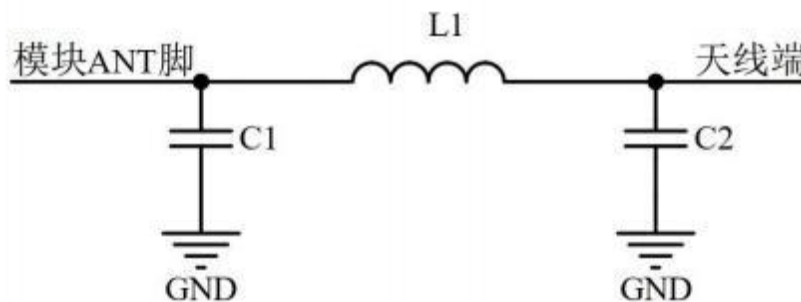

5-2 π -type matching circuit

6. Programming development

1) The DIO2 pin of the RF chip has been used for the RF signal switch control driver inside the module. When programming the driver software, it is necessary to set the working state of DIO2, just call the function `SetDio2AsRfSwitchCtrl (...)`. During normal operation, the radio frequency chip will automatically switch the output signal of DIO2 according to the wireless working mode.

```
void SX126xInit( DioIrqHandler dioIrq )
{
    SX126xReset( );
    SX126xWakeup( );
    SX126xSetStandby( STDBY_RC );

#ifdef USE_TCXO
    CalibrationParams_t calibParam;

    SX126xSetDio3AsTcxoCtrl( TCXO_CTRL_1_7V, RADIO_TCXO_SETUP_TIME << 6 );
    calibParam.Value = 0x7F;
    SX126xCalibrate( calibParam );
#endif

    SX126xSetDio2AsRfSwitchCtrl( true );
    OperatingMode = MODE_STDBY_RC;
}
```

2) The module uses an active temperature compensated crystal oscillator, and the DIO3 pin of the RF chip is used to provide power to the crystal oscillator. When programming the driver software, you need to set the function of DIO3, as shown below, open the macro definition USE_TCXO in the software, and call the function SX126xSetDio3AsTcxoCtrl() to set its function.

```

void SX126xInit( DioIrqHandler dioIrq )
{
    SX126xReset( );
    SX126xWakeup( );
    SX126xSetStandby( STDBY_RC );
#ifdef USE_TCXO
    CalibrationParams_t calibParam;
    SX126xSetDio3AsTcxoCtrl( TCXO_CTRL_3_3V, RADIO_TCXO_SETUP_TIME << 6 );
    calibParam.Value = 0x7F;
    SX126xCalibrate( calibParam );
#endif

    SX126xSetDio2AsRfSwitchCtrl( true );
    OperatingMode = MODE_STDBY_RC;
}
  
```

3) LLCC68SxxxN0SA series modules are made based on LLCC68 chips, and its driver software package is compatible with SX1262\SX1268 series. Attention should be paid to the use range of the receiving bandwidth and the spreading factor of LoRa modulation. The bandwidth BW and spreading factor SF supported by LLCC68 are listed as follows:

LoRa® Rx/ Tx , BW = 125 - 250 - 500 kHz

LoRa® SF = 5 - 6 - 7 - 8 - 9 for BW = 125 kHz

LoRa® SF = 5 - 6 - 7 - 8 - 9 - 10 for BW = 250 kHz

LoRa® SF = 5 - 6 - 7 - 8 - 9 - 10 - 11 for BW = 500 kHz

4) Generally speaking, the receiving sensitivity of the RF chip is relatively poor at the integral multiple of the operating frequency of its crystal oscillator . It is recommended that users avoid the mirror frequency of the module crystal oscillator when selecting the operating frequency, that is, the frequency of the crystal oscillator . Integer frequency point, the crystal frequency of this module is 32MHz .

7. Reflow Profile

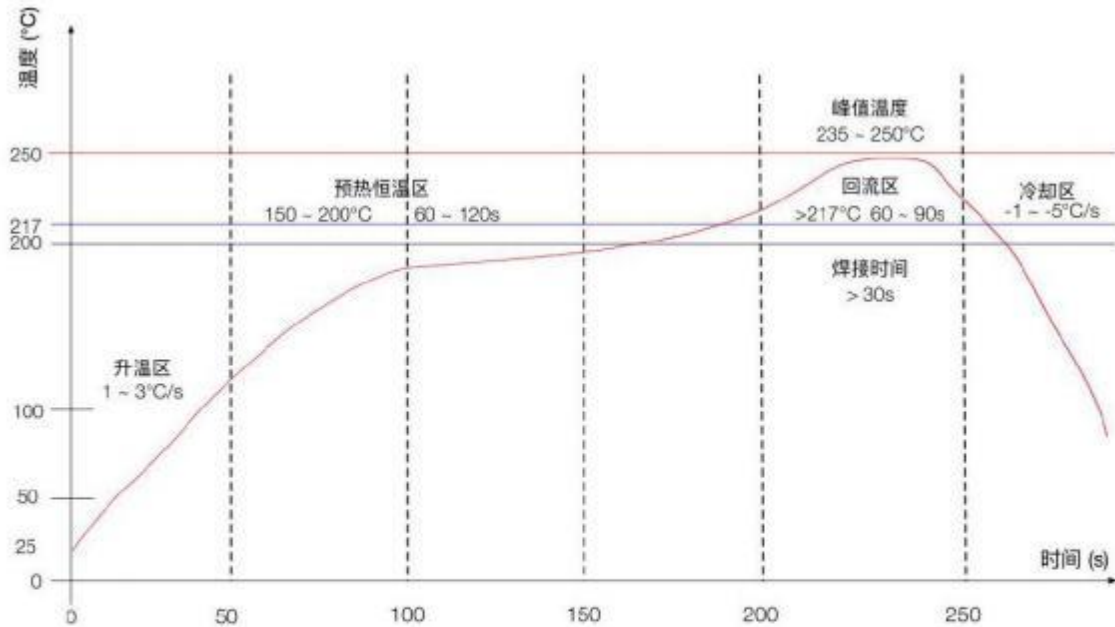

升温区 — 温度: 25 - 150°C 时间: 60 - 90s 升温斜率: 1 - 3°C/s
 预热恒温区 — 温度: 150 - 200°C 时间: 60 - 120s
 回流焊接区 — 温度: >217°C 时间: 60 - 90s; 峰值温度: 235 - 250°C 时间: 30 - 70s
 冷却区 — 温度: 峰值温度 - 180°C 降温斜率 -1 - -5°C/s
 焊料 — 锡银铜合金无铅焊料 (SAC305)

8. ESD Notice

The RF module is a high-voltage electrostatic sensitive device, in order to prevent damage to the module by static electricity

- 1、 Strictly follow anti-static measures, and do not touch the module with bare hands during production.
- 2、 Modules should be placed in a placement area that can prevent static electricity.
- 3、 The anti-static protection circuit at the high voltage input should be considered in product design.



9. Packaging information

Mechanical size (unit:mm)

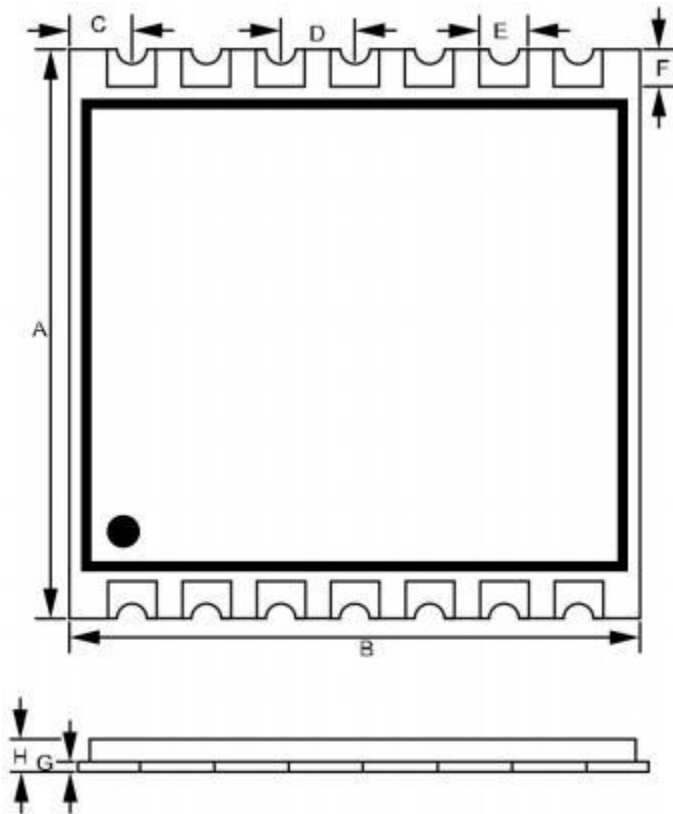

Numbering	Dimensions (mm)	Error (mm)
A	11.5	±0.5
B	11.5	±0.5
C	1.26	± 0.1
D	1.5	± 0.1
E	1.0	± 0.1
F	0.65	± 0.1
G	0.8	± 0.1
H	2.2	± 0.2

10. Revision History

Revision	Comment	Date
V1.0	first release	May 9 , 2020 _

11. Ordering Information

Index	Part Number	Description
1	LLCC68S170N0SA	170MHz frequency band, tape packing\pallet packing
2	LLCC68S433N0SA	433MHz frequency band, tape packing\pallet packing
3	LLCC68S490N0SA	490MHz frequency band, tape packing\pallet packing
4	LLCC68S868N0SA	868MHz frequency band, tape packing\pallet packing
5	LLCC68S915N0SA	915MHz frequency band, tape packing\pallet packing

12. Statement

- Due to product version upgrades or other reasons, the content of this document will be updated from time to time. Unless otherwise agreed, this document is only used as a guide, and the statements, information and recommendations in this document do not constitute any express or implied warranty.
- The company reserves the right of final interpretation and modification of all the information provided, if any changes are made without prior notice.

13. Contact us

Company: Shenzhen Vollgo Technology Co., Ltd.

Address : Room 1411, Building A, Zhiyun Industrial Park, No. 13

Huaxing Road, Henglang Community, Dalang Street, Longhua

District, Shenzhen, Guangdong

Tel: 0755-23040053

Fax: 0755-21031236

Official website: www.vollgo.com

Business cooperation: sales@vollgo.com

