

◆ Scope

This specification applies to the SLO201608T Series of SMD power inductors.

◆ Lead Free PartNumbering

SLO	201608	T	1R0	M	T	T
(1)	(2)	(3)	(4)	(5)	(6)	(7)

- (1) Series Type
- (2) Dimension: LxWxH
- (3) Material Code
- (4) Inductance:R68=0.68uH;1R0=1.0μH
- (5) Inductance Tolerance:M= ± 20%,N= ± 30%
- (6) Company Code
- (7) Packaging: packed in embossed carrier tape



◆ Dimensions

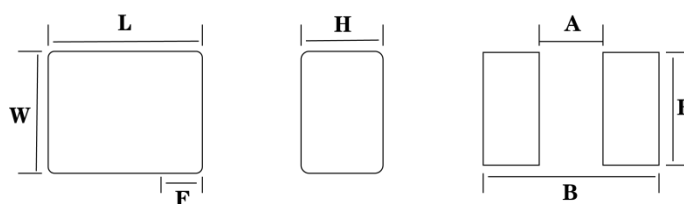

Series	L(mm)	W(mm)	H(mm)	F(mm)	Recommended Land Patterns		
					A(mm)	B(mm)	E(mm)
SLO201608T	2.0±0.2	1.6±0.2	0.8Max.	0.7±0.2	0.5Typ.	2.1Typ.	1.7Typ.

◆ Structural drawing

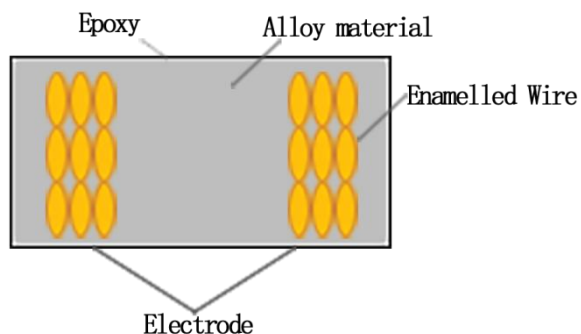

No.	Component	Material
①	Body	Alloy material
②	Winding	Enamelled Wire
③	Shield	Epoxy
④	Electric	Base plating-Cu Base plating-Ni Base plating-Sn

◆ **Specification**

Part No.	Inductance Ls(uH)	Direct Current Resistance DCR(mΩ)		Saturation Current Isat(A)		Temperature Rise Current Irms(A)	
		Max.	Typ.	Max.	Typ.	Max.	Typ.
SLO201608TR22MTT	0.22±20%	19	14	5.6	6.1	5.9	6.6
SLO201608TR24MTT	0.24±20%	20	14	5.5	6.0	5.8	6.5
SLO201608TR33MTT	0.33±20%	24	18	5.3	5.8	4.8	5.5
SLO201608TR47MTT	0.47±20%	27	24	5.0	5.5	4.4	4.6
SLO201608TR68MTT	0.68±20%	44	39	4.2	4.6	3.5	3.8
SLO201608T1R0MTT	1.0±20%	60	53	3.1	3.3	3.3	3.6
SLO201608T1R5MTT	1.5±20%	85	73	2.8	3.0	2.8	3.1
SLO201608T2R2MTT	2.2±20%	140	123	2.3	2.5	2.0	2.2
SLO201608T3R3MTT	3.3±20%	220	200	1.8	2.1	1.5	1.8
SLO201608T4R7MTT	4.7±20%	290	260	1.5	1.7	1.4	1.6
SLO201608T100MTT	10±20%	800	690	0.9	1.0	0.9	1.0

Test condition & equipment :

Item	Test condition	Test equipment
Ls	1MHz/1V	HP4263BIM3532-50 or equivalent
DCR	direct-current	HP4263BRM3545 or equivalent
Isat	1MH/1V	Microtest 6379 &6220 or equivalent
Irms	ambient temperature 20°C	Microtest 6379 &6220 or equivalent

Isat: The DC current at which the inductance drops approximate 30% from its value without current , Load current time within Ls.

Irms: The DC current is inductor surface temperature to rise by 40°C .

◆ **Operating Temperature Range**

-40°C ~ +125°C , Including self-heating

◆ **Storage Conditions**

Store products in a warehouse in compliance with the following condition:

Temperature: Inductors (product with taping) -10 to +40°C;

Inductors body -40 to +85°C .

Humidity: 30~70%RH

◆ **RECOMMENDED REFLOW PROFILE**

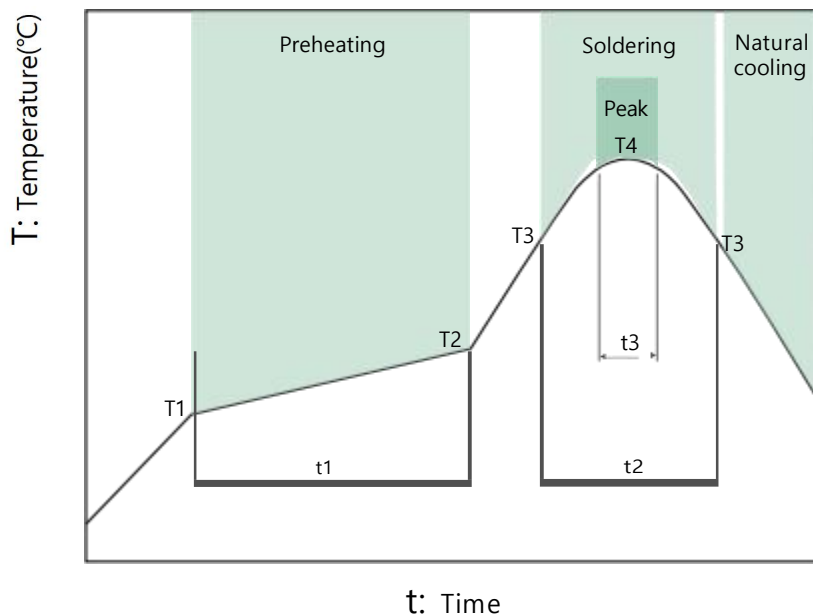

Preheating			Soldering		Peak	
Temp.		Time	Temp.	Time	Temp.	Time
T1	T2	t1	T3	t2	T4	t3
150°C	180°C	60 to 120s	230°C	30 to 50s	250 to 260°C	10s max

◆ **Reliability Mechanical**

序号 No.	项目 Items	要求 Requirements	试验方法及备注 Test Methods and Remarks
1	绝缘电阻 Insulation Resistance	$\geq 100M\Omega$	在电感器线圈和本体顶面中间施加100V直流电压保持60s。 100V DC between inductor coil and The middle of the top surface of the body for 60 seconds.
2	可焊性 Solderability	电极面90%以上覆盖新的焊料。 90% or more of electrode area shall be coated by new solder.	在 $(245 \pm 5)^\circ\text{C}$ 熔融的焊锡 (96.5Sn/3.0Ag/0.5Cu) 中浸 $(5 \pm 1)\text{s}$ 。 Dip pads in flux and dip in solder pot (96.5Sn/3.0Ag/0.5Cu) at $(245 \pm 5)^\circ\text{C}$ for (5 ± 1) seconds.
3	耐焊接热 Resistance to Soldering Heat	外观无可见机械损伤； 电感量变化率： $\pm 10\%$ 以内。 No visible mechanical damage. Inductance change: Within $\pm 10\%$	在 $(260 \pm 5)^\circ\text{C}$ 熔融的焊锡 (96.5Sn/3.0Ag/0.5Cu) 中浸 $(10 \pm 1)\text{s}$ 。 Dip pads in flux and dip in solder pot (96.5Sn/3.0Ag/0.5Cu) at $(260 \pm 5)^\circ\text{C}$ for (10 ± 1) seconds.
4	端子强度 Adhesion of terminal electrode	元件的端子与本体结合无松动、无脱落。 Strong bond between the pad and the core, without come off PC board.	将电感器用 $(260 \pm 5)^\circ\text{C}$ ， $(20 \pm 5)\text{s}$ 焊在带有 0.3 mm 厚锡膏的基板上，然后用治具垂直电极面方向加压 10N， $(10 \pm 1)\text{s}$ 。 Inductors shall be subjected to $(260 \pm 5)^\circ\text{C}$ for $(20 \pm 5)\text{s}$ Soldering in the base with 0.3mm solder. And then apply 10 N force perpendicular to electrode way for (10 ± 1) seconds.
5	耐高温 High temperature	电感量变化率： $\pm 10\%$ 以内。 No visible mechanical damage. Inductance change: Within $\pm 10\%$	温度 $(+85 \pm 2)^\circ\text{C}$ ，时间 $(96 \pm 2)\text{h}$ ； Temperature is $(+85 \pm 2)^\circ\text{C}$ and keep (96 ± 2) hours.
6	耐低温 Low temperature	外观无可见机械损伤； 电感量变化率： $\pm 10\%$ 以内。 No visible mechanical damage. Inductance change: Within $\pm 10\%$	温度 $(-40 \pm 2)^\circ\text{C}$ ，时间 $(96 \pm 2)\text{h}$ ； Temperature is $(-40 \pm 2)^\circ\text{C}$ and keep (96 ± 2) hours.

序号 No.	项目 Items	要求 Requirements	试验方法及备注 Test Methods and Remarks
7	温度变化 Therma shock	外观无可见机械损伤; 电感量变化率: ±10%以内。 No visible mechanical damage. Inductance change: Within ±10%	(-40±3) °C,时间(30±3)min↔(125°C±2)°C/(30±3)min, 转换时间(2~3)min,循环32次; 在室温下放置2小时后、 48小时内测试。 The test sample shall be placed at (-40±3)°C and(125±2) °C for(30±3)min, differenttemperature conversion time is 2~3 minutes. The temperature cycle shall be repeated 32 cycles.Placed at room temperature for 2 hours, within 48 hours of testing
8	温度特性 Temperature characteristic	电感量变化率 P_{c-b}, P_{c-d} 不超过 ±20%。 Inductance change P_{c-b}, P_{c-d} : Within ±20%	A:+20 °C (30~45) min → b:- 40 °C (30~45) min → c:+20 °C (30~45) min → d:+125 °C (30~45) min → e:+20 °C (30~45) min $P_{c-b} = \frac{L_b - L_c}{L_c} \times 100\%$; $P_{c-d} = \frac{L_d - L_c}{L_c} \times 100\%$
9	恒定湿热 Static Humidity	外观无可见机械损伤; 电感量变化率: ±10%以内。 No visible mechanical damage. Inductance change: Within ±10%	将电感器放置在于湿度(93±3)%RH,温度(40±2)°C的环 境中存放(1000±2)h, 在室温下放置2小时后、48小时 内测试。 Inductors shall be subjected to(93±3)%RH. at (60±2) °C for (96±2)h.Placed at room temperature for 2 hours, within 48 hours of testing.
10	耐久性 (寿命) Life	外观无可见机械损伤; 电感量变化率: ±10%以内。 No visible mechanical damage. Inductance change: Within ±10%	温度(85±2)°C, 时间(1000±24)h,施加Irms, 在室温下放 置2小时后、48小时内测试。 Inductors shall be store at (85±2) °C for (1000±24) hours with Irms applied.Placed at room temperature for 2 hours, within 48 hours of testing.

◆ Taping reel dimensions

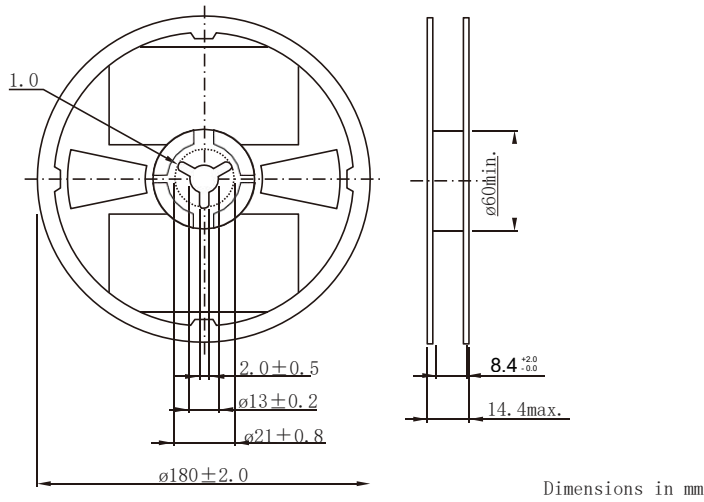

◆ Carrier tape dimensions

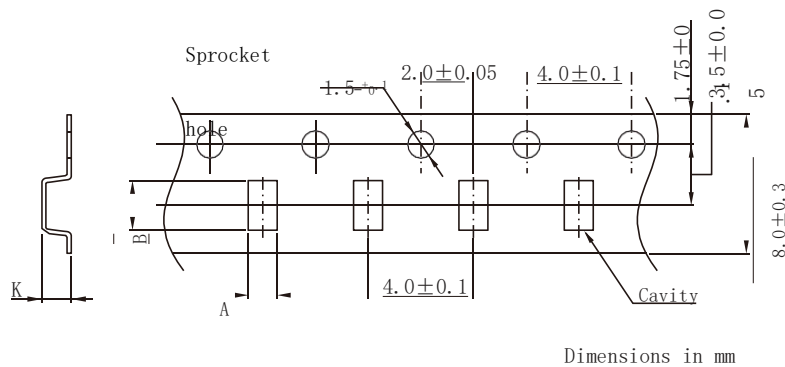

Series Type	A	B	K
SL0201608T	1.9	2.35	1.0

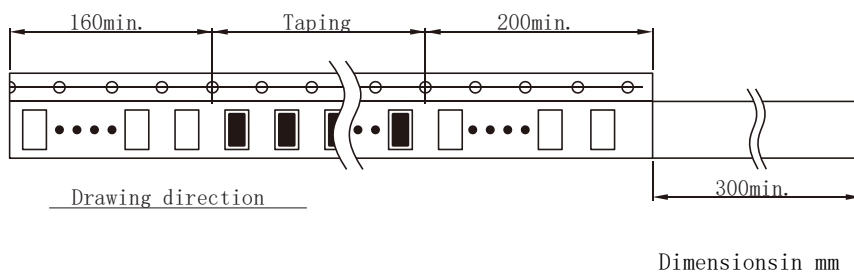

◆ Package quantity

Package quantity	3000 pcs/reel
------------------	---------------