

Product Summary

- V_{DS} -20 V
- I_{DS} (@ $V_{GS} = -4.5V$) -7.0 A
- $R_{DS(ON)}$ (@ $V_{GS} = -4.5V$) $\leq 30m\Omega$

Application

- Reverse Battery protection
- Load switch
- Power management
- PWM Application

Package and Pin Configuration

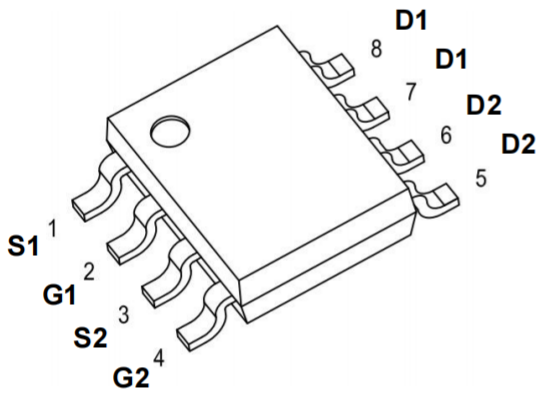

SOP8

Circuit diagram

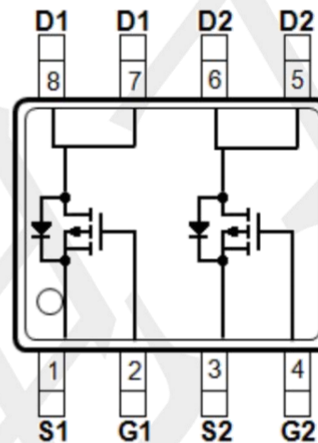

Absolute Maximum Ratings (T_A=25°C unless otherwise noted)

PARAMETER	SYMBOL	LIMIT	UNIT
Drain-Source Voltage	V_{DS}	-20	V
Gate-Source Voltage	V_{GS}	± 12	V
Continuous Drain Current	I_D	-7.0	A
Pulsed Drain Current (note1)	I_{DM}	-30	A
Maximum Power Dissipation	P_D	3.0	W
Operating Junction Temperature Range	T_J	-55 to +150	°C
Storage Temperature Range	T_{stg}	-55 to +150	°C

Thermal Characteristic

PARAMETER	Symbol	Value	Unit
Thermal Resistance from Junction to Ambient (t $\leq 10s$)	$R_{\theta JA}$	40	°C/W
	PCB Mount (note2)		

notes 1. Repetitive Rating: Pulse width limited by maximum junction temperature.

2. When mounted on 1" square PCB (FR4 material).

Electrical Characteristics (T_A=25°C unless otherwise noted)

PARAMETER	CONDITIONS	SYMBOL	MIN	TYP	MAX	UNIT
Static						
Drain-Source Breakdown Voltage	V _{GS} =0V, I _D =-250μA	BV _{DSS}	-20	-23	--	V
Gate-Source Threshold Voltage	V _{DS} =V _{GS} , I _D =-250μA	V _{GS(th)}	-0.4	-0.7	-1.0	V
Gate-Source Leakage	V _{DS} =0V, V _{GS} = ±12V	I _{GSS}	--	--	±100	nA
Zero Gate Voltage Drain Current	V _{DS} = -20V, V _{GS} =0V	I _{DSS}	--	--	-1	μA
	V _{DS} = -20V, T _J =55°C		--	--	-25	μA
Drain-Source On-State Resistance (Note 1)	V _{GS} = -4.5V, I _D = -4.2A	R _{DS(on)}	--	21	30	mΩ
	V _{GS} = -2.5V, I _D = -2.9A		--	28	35	
Forward Transconductance (Note 2)	V _{DS} = -15V, I _D = -4.5A	g _{fs}	--	7	--	S
Dynamic (Note 2)						
Total Gate Charge (Note 3)	V _{DS} = -10V, I _D = -4.2A, V _{GS} = -4.5V	Q _g	--	12	--	nC
Gate-Source Charge (Note 3)		Q _{gs}	--	2.4	--	
Gate-Drain Charge (Note 3)		Q _{gd}	--	3.2	--	
Input Capacitance	V _{DS} = -15V, V _{GS} = 0V, F = 1.0MHz	C _{iss}	--	540	--	pF
Output Capacitance		C _{oss}	--	150	--	
Reverse Transfer Capacitance		C _{rss}	--	75	--	
Switching						
Turn-On Delay Time (Note 3)	V _{DD} = -15V, I _D = -1.0A, V _{GS} = -10V, R _{GEN} = 6Ω	t _{d(on)}	--	8	--	nS
Rise Time (Note 3)		t _r	--	14	--	
Turn-Off Delay Time (Note 3)		t _{d(off)}	--	18	--	
Fall Time (Note 3)		t _f	--	10	--	
Source-Drain Diode Ratings and Characteristics (Note 2)						
Forward Voltage	V _{GS} = 0V, I _{SD} = -4.2A	V _{SD}	--	-0.78	-1.2	V
Continuous Source Current	Integral reverse diode in the MOSFET	I _S	--	--	-7.0	A
Pulsed Current (Note 1)		I _{SM}	--	--	-30	A

Notes:

1. Pulse test; pulse width ≤ 300 μs, duty cycle ≤ 2%.
2. Guaranteed by design, not subject to production testing.
3. Independent of operating temperature

TYPICAL CHARACTERISTICS (25 °C, unless otherwise noted)

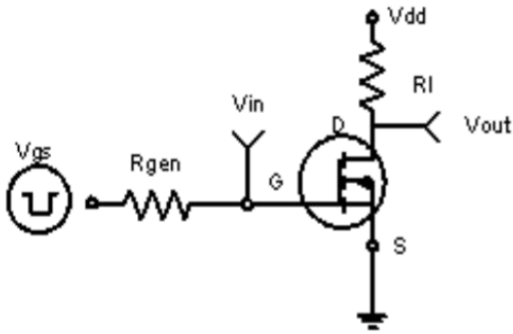

Figure 1 Switching Test Circuit

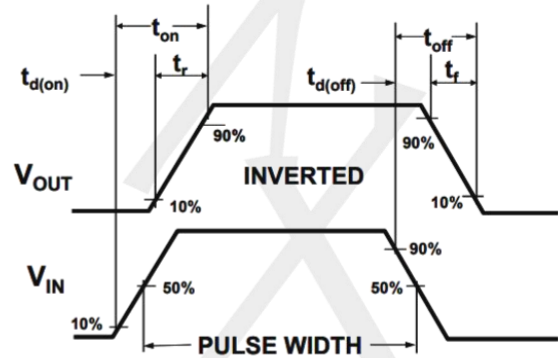

Figure 2 Switching Waveforms

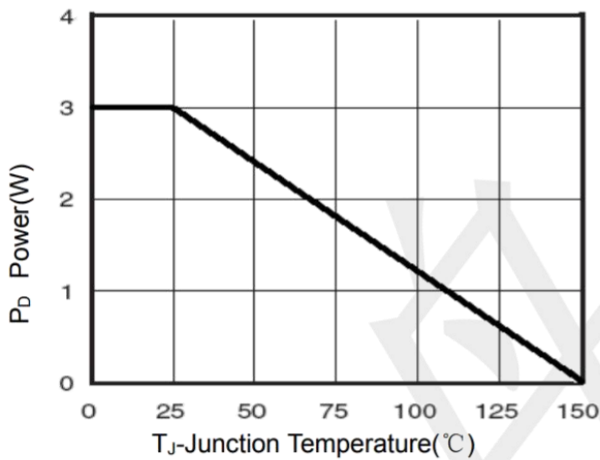

Figure 3 Power Dissipation

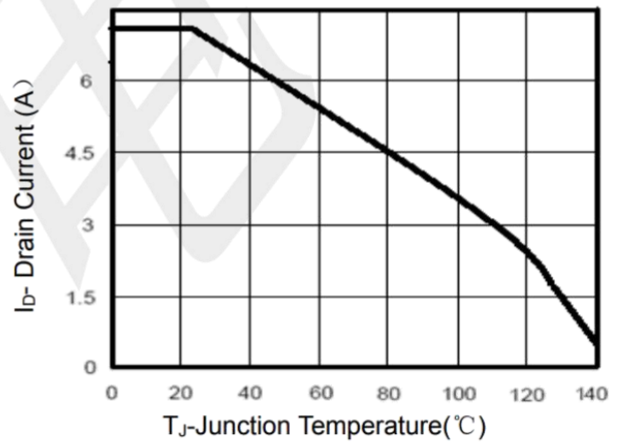

Figure 4 Drain Current

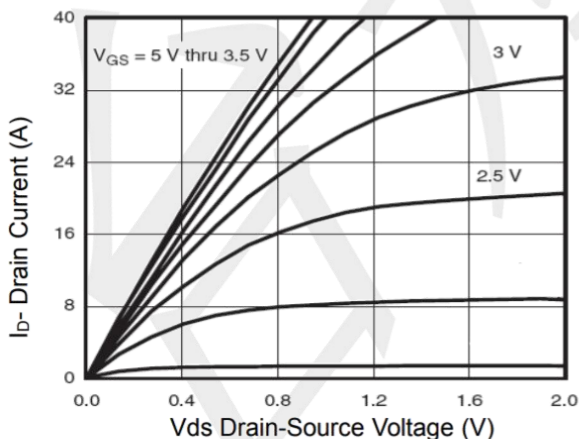

Figure 5 Output Characteristics

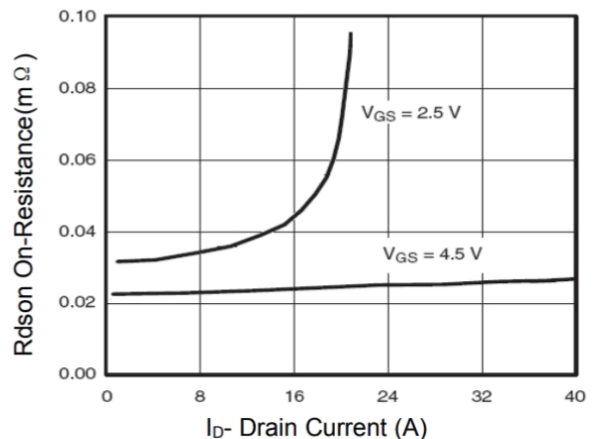
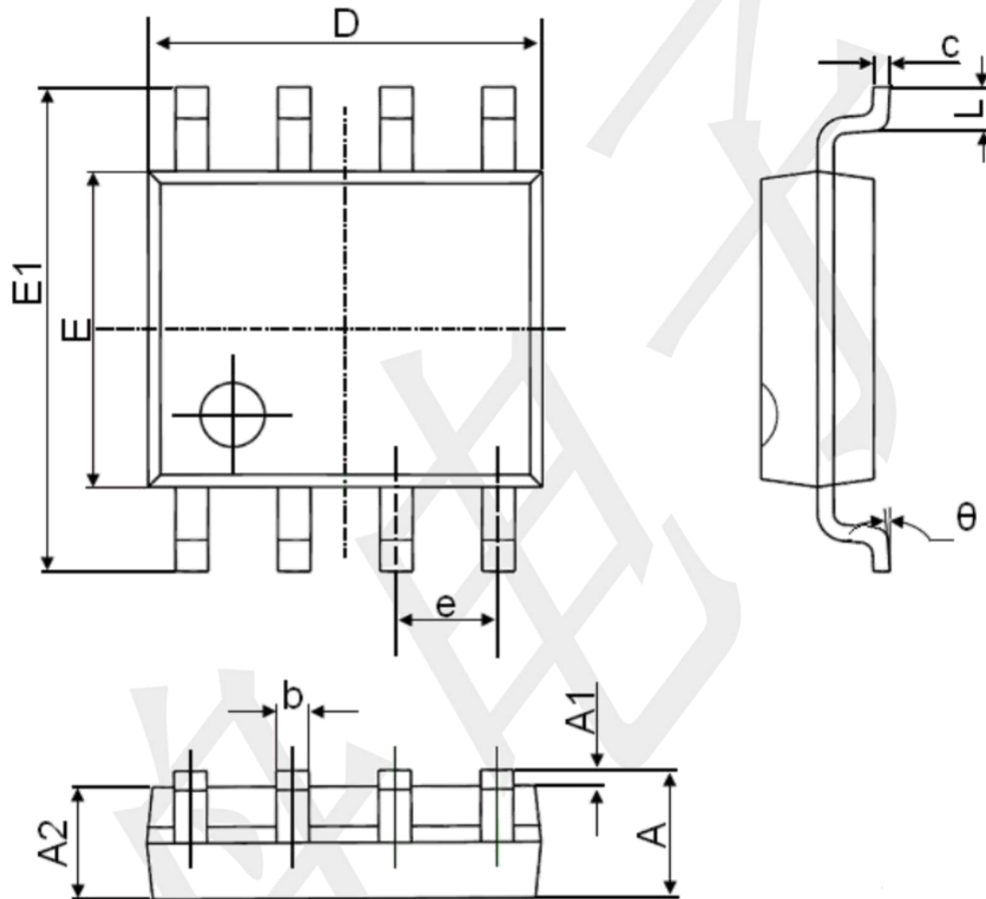

Figure 6 Drain-Source On-Resistance

Package Information SOP8



Symbol	Dimensions In Millimeters		Dimensions In Inches	
	Min.	Max.	Min.	Max.
A	1.350	1.750	0.053	0.069
A1	0.100	0.250	0.004	0.010
A2	1.350	1.550	0.053	0.061
b	0.330	0.510	0.013	0.020
c	0.170	0.250	0.006	0.010
D	4.700	5.100	0.185	0.200
E	3.800	4.000	0.150	0.157
E1	5.800	6.200	0.228	0.244
e	1.270(BSC)		0.050(BSC)	
L	0.400	1.270	0.016	0.050
theta	0°	8°	0°	8°