

Features

BV_{DSS}	30V
$R_{DS(ON)}$	150m Ω
I_D	1.4A

Application

- Load/Power Switching
- Interfacing Switching
- Battery Management for Ultra Small Portable Electronics
- Logic Level Shift
- SI1308EDL-T1-GE3 pin to pin fully compatible

Package and Pin Configuration



SOT323

Circuit diagram

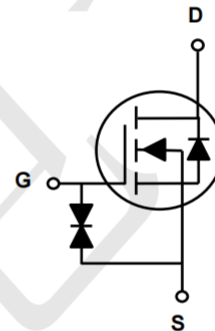

Absolute Maximum Ratings ($T_A=25^\circ\text{C}$ unless otherwise noted)

Parameter	Symbol	Max.	Unit
Drain-Source Voltage	V_{DS}	30	V
Gate-Source Voltage	V_{GS}	± 12	V
Drain Current-Continuous($T_C=25^\circ\text{C}$)	I_D	1.4	A
Drain Current-Pulsed ¹	I_{DM}	6	A
Power Dissipation($T_C=25^\circ\text{C}$)	P_D	360	mW
Power Dissipation-Derate Above 25°C		1.25	mW/ $^\circ\text{C}$
Storage Temperature Range	T_{STG}	-55 To +150	$^\circ\text{C}$
Operating Junction Temperature Range	T_J	-55 To +150	$^\circ\text{C}$

Electrical Characteristics ($T_A = 25^\circ\text{C}$ unless otherwise noted)

Parameter	Symbol	Conditions	Min.	Typ.	Max.	Unit
Off Characteristics						
Drain-Source Breakdown Voltage	BV_{DSS}	$V_{GS}=0V, I_D=250\mu A$	30	-	-	V
BV_{DSS} Temperature Coefficient	$\Delta BV_{DSS}/\Delta T_J$	Reference to 25°C , $I_D=1mA$	-	-0.03	-	$V/^\circ\text{C}$
Drain-Source Leakage Current	I_{DSS}	$V_{DS}=30V, V_{GS}=0V,$ $T_J=25^\circ\text{C}$	-	-	1	μA
		$V_{DS}=24V, V_{GS}=0V,$ $T_J=125^\circ\text{C}$	-	-	10	μA
Gate-Source Leakage Current	I_{GSS}	$V_{GS}=\pm 12V, V_{DS}=0V$	-	-	± 20	μA
On Characteristics						
Static Drain-Source On-Resistance	$R_{DS(ON)}$	$V_{GS}=4.5V, I_D=0.5A$	-	150	200	m Ω
		$V_{GS}=2.5V, I_D=0.5A$	-	200	300	
Gate Threshold Voltage	$V_{GS(th)}$	$V_{DS}=V_{GS}, I_D=250\mu A$	0.5	0.8	1.5	V
$V_{GS(th)}$ Temperature Coefficient	$\Delta V_{GS(th)}$		-	-1.74	-	mV/ $^\circ\text{C}$
Forward Transconductance	g_{FS}	$V_{DS}=4V, I_D=0.3A$	-	1	-	S
Dynamic and Switching Characteristics						
Total Gate Charge ^{2,3}	Q_g	$V_{DS}=15V, I_D=0.3A,$ $V_{GS}=4.5V$	-	2.6	5.2	nC
Gate-Source Charge ^{2,3}	Q_{gs}		-	0.9	1.8	
Gate-Drain Charge ^{2,3}	Q_{gd}		-	0.6	1.2	
Turn-On Delay Time ^{2,3}	$t_{d(on)}$	$V_{DD}=15V, R_G=10\Omega$ $V_{GS}=4.5V, I_D=0.3A$	-	5.5	11	nS
Rise Time ^{2,3}	t_r		-	4	8	
Turn-Off Delay Time ^{2,3}	$t_{d(off)}$		-	14.5	29	
Fall Time ^{2,3}	t_f		-	6.5	13	
Input Capacitance	C_{iss}	$V_{DS}=15V, V_{GS}=0V,$ $F=1MHz$	-	100	146	PF
Output Capacitance	C_{oss}		-	18.3	36.6	
Reverse Transfer Capacitance	C_{rss}		-	7.4	14.8	
Drain-Source Diode Characteristics and Maximum Ratings						
Continuous Source Current	I_S	$V_G=V_D=0V,$	-	-	1.4	A
Pulsed Source Current	I_{SM}	Force Current	-	-	6	
Diode Forward Voltage	V_{SD}	$V_{GS}=0V, I_S=0.2A,$ $T_J=25^\circ\text{C}$	-	-	1.2	V
Reverse Recovery Time	T_{rr}	$V_{GS}=0V, I_S=0.3A,$ $d_i/d_f=100A/\mu s,$	-	13	-	nS
Reverse Recovery Charge	Q_{rr}	$T_J=25^\circ\text{C}$	-	6	-	nC

Outline Drawing - SOT323(SC70-3)

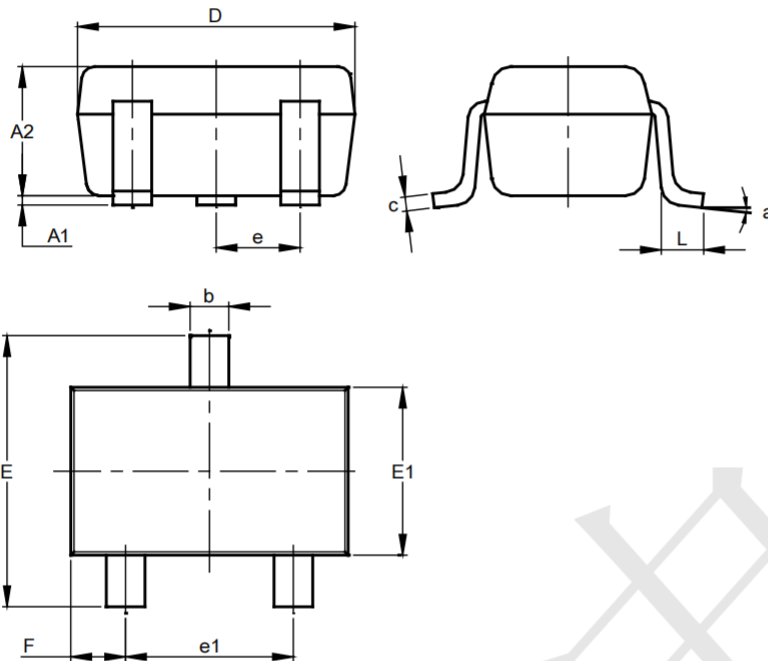

SOT323			
Dim	Min	Max	Typ
A1	0.00	0.10	0.05
A2	0.90	1.00	0.95
b	0.25	0.40	0.30
c	0.10	0.18	0.11
D	1.80	2.20	2.15
E	2.00	2.20	2.10
E1	1.15	1.35	1.30
e	0.650 BSC		
e1	1.20	1.40	1.30
F	0.375	0.475	0.425
L	0.25	0.40	0.30
a	0°	8°	--
All Dimensions in mm			

Land Pattern - SOT323

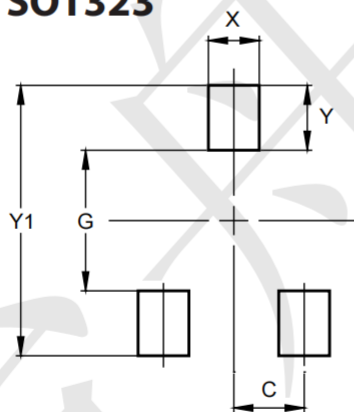

Dimensions	Value (in mm)
C	0.650
G	1.300
X	0.470
Y	0.600
Y1	2.500