

1. 跷板开关型号ROCKER SWITCH MODEL SS11-WWIBQ-R20-R
 2. 快插端子QUICK CONNECTOR TYPE;
 单刀单掷 (SINGLE POLE SINGLE THROW);
 3. 额定值RATING:16A 125/250VAC (UL;C-UL);
 12A 125/250VAC (UL;C-UL);
 16(4)A 250V~T125/55(ENEC17;NEMKO;CQC;CB)

UL APPROVAL FILE NO.:E153399
 ENEC CERTIFICATE NO.:NO3715
 NEMKO CERTIFICATE NO.:P09211556/A1
 CQC CERTIFICATE NO.10002049681
 CB CERTIFICATE NO.:NO62986/A2

4. 柄的颜色ACTUATOR COLOR: 白色WHITE
 基座的颜色HOUSING COLOR: 白色WHITE
 5. 柄的印字形式ACTUATOR PRINTING:" 16(4)A 250V~T125/55" 黑色BLACK COLOR
 6. 所有部件均使用环保材料
 ALL MATERIALS USE IN CONFORMITY WITH THE RoHS DIRECTIVE
 7. "○"关键尺寸DENOTES CRITICAL DIMENSIONS.

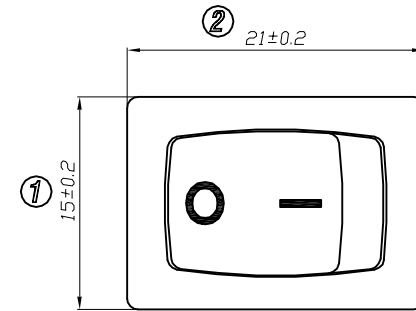
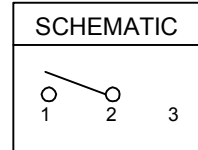

TEL: 0769-82310511-867

PANEL CUTOUT DIMENSION

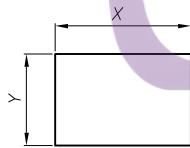

PANEL THICKNESS	X	Y
0.8~1.2mm	19.2 ⁺⁰ _{-0.1} mm	12.9 ^{+0.1} ₋₀ mm
1.3~2.0mm	19.4 ⁺⁰ _{-0.1} mm	12.9 ^{+0.1} ₋₀ mm
2.1~2.5mm	19.8 ⁺⁰ _{-0.1} mm	12.9 ^{+0.1} ₋₀ mm

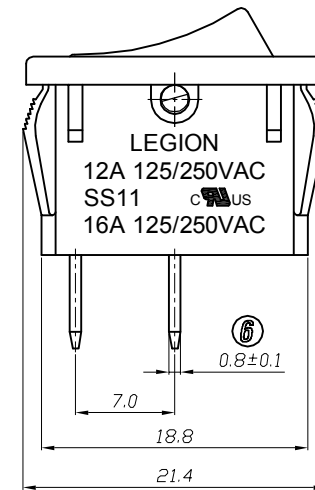
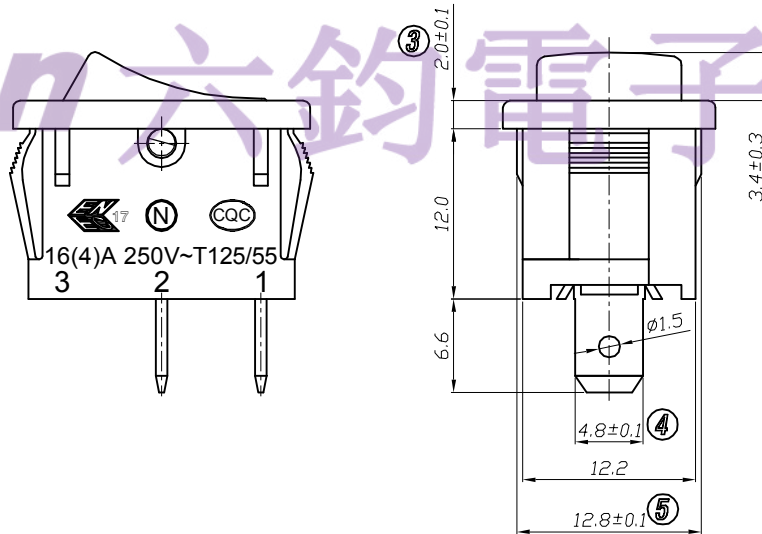

NO	DESCRIPTION	NO	DESCRIPTION	DIMENSIONAL TOLERANCES		APPROVED	CHECKED	DESIGN	DRAWN	ALL SIZE ARE IN			
				RANGE	TOLERANCE					MM	NO		
				X	±0.30					MAT'L	***		
				X.X	±0.20					MATERIAL NO.		DRAWING NO.	REV.
				X.XX	±0.10								
				ANGLES	±1°								
LEGION ELECTRONIC & HARDWARE CO., LTD.										SS11-WWIBQ-R20-R	WIF119011	A	