

## Specification Sheet for Approved

Customer Name:	
Customer Part No.:	
Ceaiya Part No:	CMPI0412 Series
Spec No:	L0412

### 【For Customer Approval Only】

If you Approval, Please Stamp

### 【RoHS Compliant Parts】

Approved By	Checked By	Prepared By
李庆辉	苏高峰	劳水花

## Shenzhen Ceaiya Electronics Co., Ltd.

地址 1: 深圳市龙华区观湖街道鹭湖社区观盛二路 5 号捷顺科技中心 B706

地址 2: 东莞清溪镇青滨东路 105 号力合紫荆智能制造中心 10 栋

Http: //www.szceaiya.com

Tel: 0769-89333213



# Specification Sheet for SMD Power Inductor

## 1. Scope

This specification applies to the CMPI0412 Series of wire wound SMD power inductor.

## 2. Product Description and Identification (Part Number)

1) Description:

CMPI0412 series of Wire wound SMD power inductor.

2) Product Identification (Part Number)

CMPI      0412      -      1R0      M  
 ①              ②                              ③              ④

- ① Product Series
- ② ChokeSize
- ③ InitialInductance(L@ 0A):1R0=1.0μH
- ④ InductanceTolerance:M= ± 20%

## 3. Electrical Characteristics

- 1) Operating temperature range (individual chip without packing): -40°C ~ +125°C (Including Self-heating)
- 2) Storage temperature range (On PCB ): -40°C ~ +125°C

## 4. Shape and Dimensions (Unit:mm)

### MECHANICALPARAMETERS

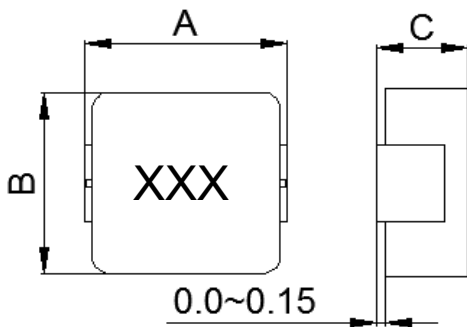

### RECOMMENDEDPCBLAYOUT

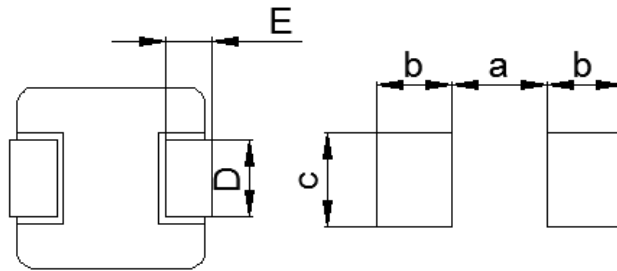

A	B	C	D	E	a	b	c
4.50	4.20	1.0	2.0	0.8	2.2	1.5	2.5
±0.35	±0.25	±0.2	±0.30	±0.30	Typ.	Typ.	Typ.

### Notes:

1. Marking: Ink Marking
2. Stamping XXX : inductor
3. Dimensions of recommended PCB layout are reference only.
4. Do not route traces nor place vias underneath the inductor. Proper layout is required.

## Specification Sheet for SMD Power Inductor

### 5. Electrical Characteristics

Part Number	L0(uH) ±20%	DCR(mΩ) @25°C		Isat(Amp) Typ.	Irms(Amp) Typ.	Marking
		Max.	Typ.			
CMPI0412-R22M	0.22	11.0	9.5	15.0	7.5	R22
CMPI0412-R33M	0.33	19.0	17.0	8.4	6.5	R33
CMPI0412-R47M	0.47	21	19	6.8	6.0	R47
CMPI0412-R68M	0.68	36	32	6.0	4.7	R68
CMPI0412-1R0M	1.0	47	43	5.5	4.5	1R0
CMPI0412-1R5M	1.5	75	68	4.0	3.25	1R5
CMPI0412-2R2M	2.2	85	79.3	3.0	2.75	2R2
CMPI0412-3R3M	3.3	160	145	2.7	2.0	3R3
CMPI0412-4R7M	4.7	200	175	2.2	1.8	4R7

#### Notes:

1. Initial Inductance (L<sub>0</sub>) Test Parameters: 100KHz, 1V, I<sub>dc</sub>=0.0A, +25°C
2. All test data is referenced to 25°C ambient;
3. Rated current: Isat or Irms, whichever is smaller;
4. Isat(A):DC current at which the inductance drops approximate 30% from its value without current;
5. Irms(A):DC current that causes the temperature rise ( $\Delta T = 40^\circ \text{C}$ ) from 25° C ambient.

# Specification Sheet for SMD Power Inductor

## 6. Reliability Test

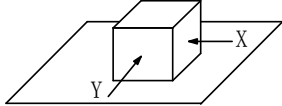
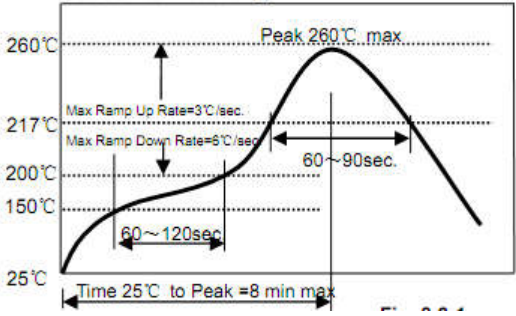
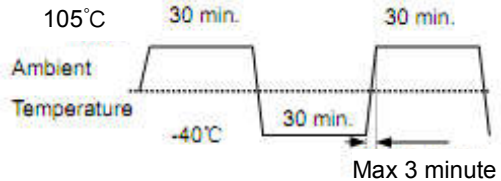
Items	Requirements	Test Methods and Remarks
6.1 Terminal Strength	No removal or split of the termination or other defects shall occur.   Fig.6.1-1	1) Solder the inductor to the testing jig (glass epoxy board shown in Fig.6.1-1) using eutectic solder. Then apply a force in the direction of the arrow. 2) 10N force. 3) Keep time: 5±2s
6.2 High Temperature	1. No visible mechanical damage. 2. Inductance change: Within ±10%	1) Storage Temperature :125+/-5°C 2) Duration : 96 ±4 Hours 3) Recovery : then measured at room ambient temperature after placing 24 hours.
6.3 Low Temperature	1. No visible mechanical damage 2. Inductance change: Within ±10%	1) Temperature and time: -40±5°C 2) Duration: 96±4 hours 3) Recovery : then measured at room ambient temperature after placing 24 hours.
6.4 Vibration test	1. No visible mechanical damage. 2. Inductance change: Within ±10%	1) Frequency range:10Hz~55Hz~10Hz 2) Amplitude:1.5mm p-p 3) Direction:X,Y,Z 4) Time:1 minute/cycle,2hours per axis
6.5 High Temperature Storage Tested	1. No visible mechanical damage. 2. Inductance change: Within ±10%	1)Storage Temperature :60+/-2°C 2) Relative Humidity :90-95% 3) Duration : 96 ±4 Hours 4)Recovery : then measured at room ambient temperature after placing 24 hours.
6.6 Resistance to Soldering Heat	1. No visible mechanical damage. 2. Inductance change: Within ±10%   Fig.6.6-1	1) Re-flowing Profile: Please refer to Fig.6.6-1 2) Test board thickness: 1.0mm 3) Test board material: glass epoxy resin 4) The chip shall be stabilized at normal condition for 1~2 hours before measuring
6.7 Thermal Shock	1. No visible mechanical damage. 2. Inductance change: Within ±10%   Fig.6.7-1	1) Temperature and time: -40±3°C for 30±3 min→105°C for 30±3min, please refer to Fig.6.7-1. 2) Transforming interval: Max,3 minutes 3) Tested cycle: 100 cycles 4) The chip shall be stabilized at normal condition for 1~2 hours before measuring

# Specification Sheet for SMD Power Inductor

## 7. MATERIALLIST

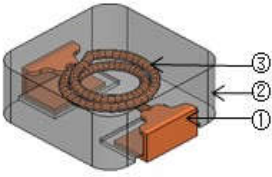

NO.	Part Name	Material
1	Electrode	Cu+Snplating
2	Core	Metalcompositecore
3	Coil	Copperwire,220°C

## 8. PACKAGE INFORMATION-mm

### 8.1 Tape Packaging Dimensions

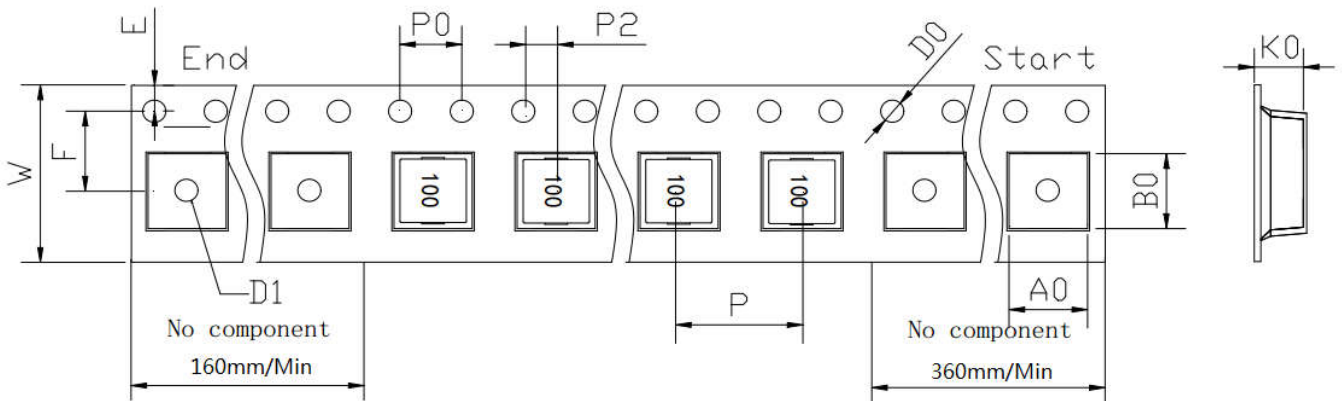

Item	W	A0	B0	K0	P	F	E	D0	D1	P0	P2	T
DIM	12.0	4.4	4.9	1.5	8.0	5.5	1.75	1.5	1.5	4.0	2.0	0.35
Tole	±0.3	Typ.	Typ.	Typ.	±0.1	±0.1	±0.1	±0.1	±0.0	±0.1	±0.1	Typ.

### 8.2 Reel Dimensions

直径 Diameter: 330mm (13')

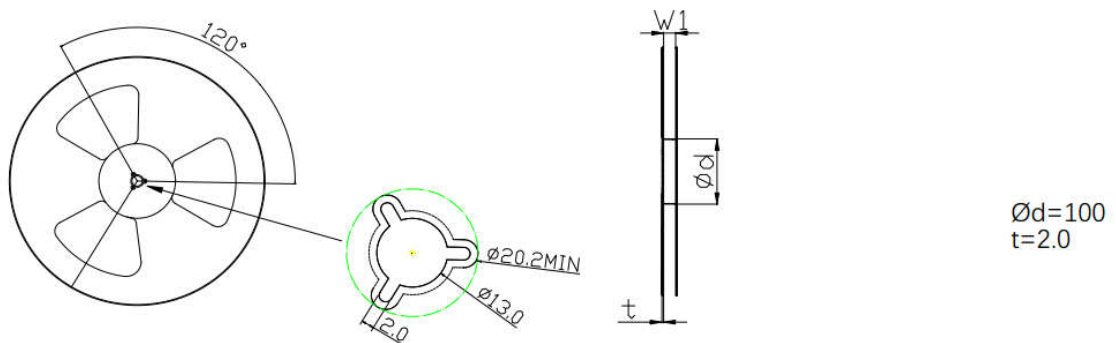

## Specification Sheet for SMD Power Inductor

### 盖带剥离条件 Cover tape peel off condition

- 盖带剥离力度为0.1~1.3N。Cover Tape peel force shall be 0.1 to 1.3N.
- 参考剥离速度 $300\pm 10$ mm/分钟。Reference peel speed  $300\pm 10$ mm/min.

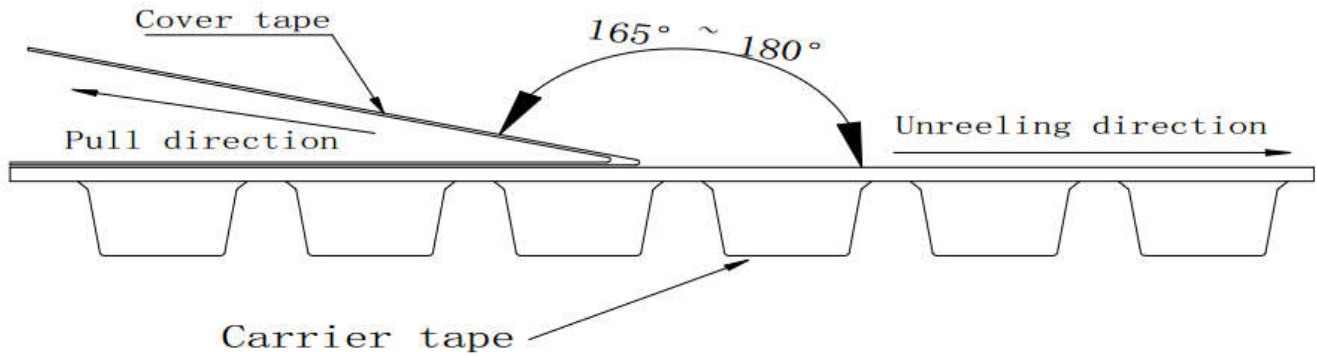

### 8.3 Taping Quantity

4000pieces/Reel,

### 8.4 Carton

Pizza packaging: 3Reel/ Pizza Box

External Packaging :3 Boxes/Carton