PCB Layout Guide for MEC172x

<i>Author: Tom Rubino Microchip Technology Inc.</i>

INTRODUCTION

This application note provides information on design considerations for a printed circuit board (PCB) for the Microchip MEC1721/MEC1723 device.

The design of the PCB requires care to provide good supply and ground paths; in addition, other design issues are addressed in this document.

The functional blocks in the MEC1721/MEC1723 have different requirements for routing and external connections, which are also outlined in this application note.

Please see [References](#) for device-level information such as V_{CC1} power planes, and mechanical package information for the 176-Pin WFBGA.

This document includes the following topics:

- [Section 1.0, "General Layout Considerations," on page 2](#)
- [Section 2.0, "Miscellaneous Considerations," on page 9](#)
- [Section 3.0, "JTAG Design and Layout Guide," on page 24](#)
- [Section 4.0, "Boards bring-up debug tips," on page 29](#)

Audience

This document is written for a reader that is familiar with hardware design. The goal of this application note is to provide information about sensitive areas of the MEC1721/MEC1723 PCB layout.

References

The following documents should be referenced when using this application note. Please contact your Microchip representative for availability.

- Microchip MEC1721/MEC1723 Data Sheet
- Microchip MEC1721/MEC1723 EVBs, ASSY. 6906A
- PCI Local Bus Specification (see www.pcisig.com)
- I²C-bus specification and user manual, Rev. 6 - 4 April, 2014 or later (see www.nxp.com/documents/user_manual/UM10204.pdf)
- Intel, Enhanced Serial Peripheral Interface (eSPI) Specification (for Client Platform)
- Microchip "eSPI Controller" Specification

Package Information

The MEC1721/MEC1723 device is currently available in the following packages:

- MEC1721/MEC1723 for 176-pin, WFBGA/LJ
- MEC1721/MEC1723 for 144-pin, WFBGA/SZ

AN3759

1.0 GENERAL LAYOUT CONSIDERATIONS

This section describes layout considerations for the MEC1721/MEC1723 device. This includes the following topics:

- [Section 1.1, "Decoupling Capacitors," on page 2](#)
- [Section 1.2, "32.768kHz Crystal Oscillator," on page 5](#)
- [Section 1.3, "CAP Pins, AVSS/GND Connection," on page 6](#)
- [Section 1.4, "BGA Package PCB Layout Considerations," on page 6](#)

1.1 Decoupling Capacitors

This section includes the following topics:

- [Section 1.1.1, "MEC1721/MEC1723 WFBGA Capacitors," on page 2](#)

Decoupling capacitors should be placed as close to the chip as possible to keep series inductance low. When the capacitors are mounted on the bottom side of the PCB, the capacitors are connected to the ground plane from the bottom layer directly using the shortest path to the device. Each VCC pin should have a 0.1 μ F capacitor located as close to the pin as possible. Bypass capacitors should be placed close to the supply pins of the MEC1721/MEC1723 with short and wide traces.

The MEC1721/MEC1723 has an integrated voltage regulator to supply the core circuitry. Decoupling this regulator requires a critical capacitor of 1 μ F on the CAP pin. ESR of this 1 μ F capacitor, including the routing resistance, must be less than 100 mOhm.

Capacitors may carry large currents that generate magnetic fields, inducing noise on nearby traces. Sensitive traces such as the 32kHz crystal should be separated by at least five times the trace width from decoupling capacitors when possible.

Connecting decoupling caps to power and ground planes using two vias per pad will reduce series inductance.

- [FIGURE 1-1: on page 3](#) shows decoupling for the MEC1721/MEC1723 176-pin WFBGA.

The VCC pin decoupling capacitors can use any typical 16V 10% Ceramic. See also the MEC1721/MEC1723 EVB Schematics and Bill of Materials.

1.1.1 MEC1721/MEC1723 WFBGA CAPACITORS

- [Figure 1-1](#) shows decoupling for the MEC1721/MEC1723 176-pin WFBGA package.

Note: The capacitors can use any typical 16V 10% ceramic.
--

FIGURE 1-1: MEC1721/MEC1723 DECOUPLING IN 176-PIN WFBGA/LJ PACKAGE

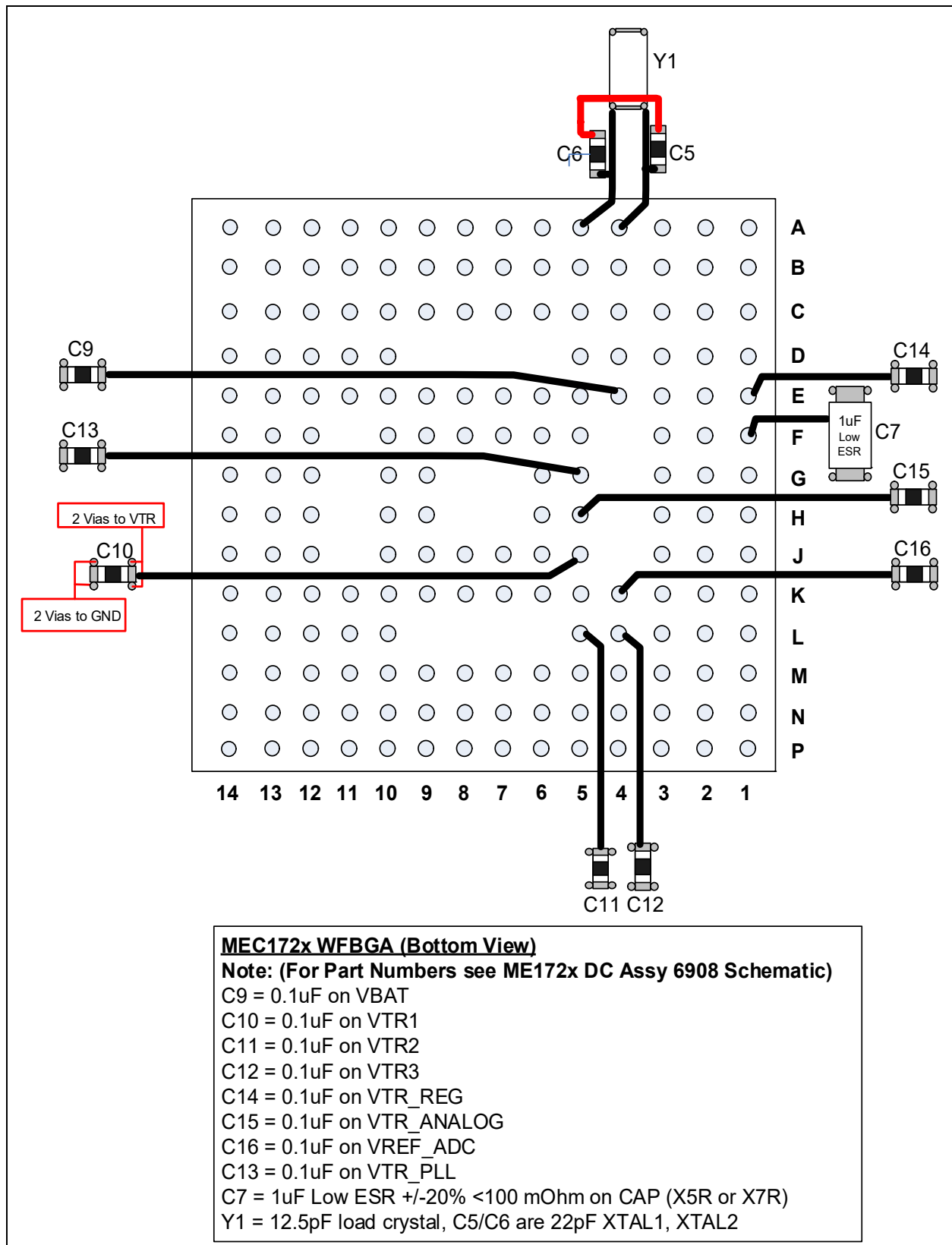

AN3759

FIGURE 1-2: MEC1721/MEC1723 DECOUPLING IN 144-PIN WFBGA/SZ PACKAGE

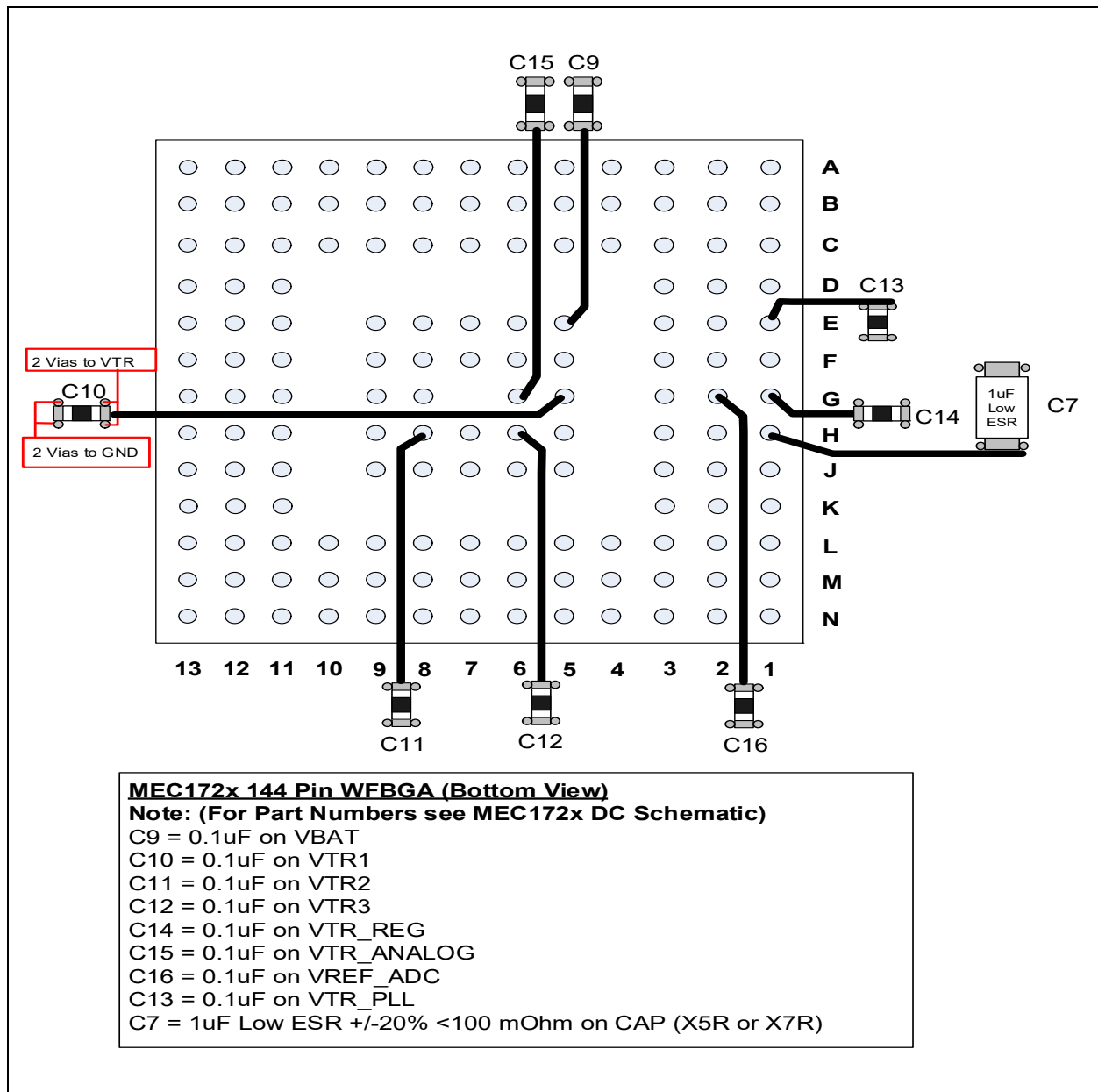

1.2 32.768kHz Crystal Oscillator

The following formula may be used to calculate a parallel resonant crystal's external load capacitors:

$$CL = ((CX1 \times CX2) / (CX1 + CX2)) + Cstray$$

where:

CL = the crystal load capacitance

Cstray = the stray capacitance in the oscillator circuit, which will normally be in the 2pF to 5pF range.

Assuming that $CX1=CX2$ then the equation becomes:

$$CL = ((CX1 \times CX1) / (2 \times CX1)) + Cstray$$

$$CL = (CX1 / 2) + Cstray$$

Rearranging the equation, we can find the external load capacitor value:

$$CX1 = 2(CL - Cstray)$$

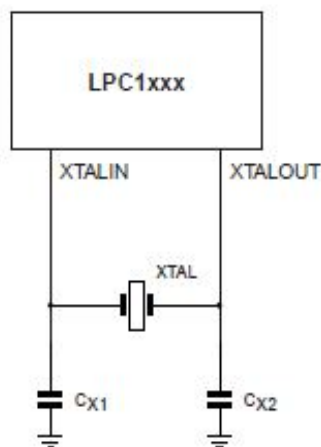

The formula parameters:

CL is the crystal's load cap, CX1 is equivalent to C12 and Cx2 is equivalent to C13 in our doc are the cap from pin to ground

The Cstray = trace Length cap (board layout) + pin cap (package) + pads parasitic cap (pad library)

1.2.1 SINGLE ENDED CLOCKING

An External Crystal Oscillator can be used with MEC172x for sourcing the 32kHz clock domain. For dual ended configuration, XTAL is connected between XTAL1 and XTAL2.

For Single ended XTAL configuration, external clock should be connected to XTAL2 pin and XTAL1 pin should be grounded. If the 32KHz source will never be the crystal oscillator, then the XTAL1 and XTAL2 pins should be grounded.

AN3759

1.3 CAP Pins, AVSS/GND Connection

The recommended filtering for the CAP pin on the MEC1721/MEC1723 is shown in Figure 1-3, for WFBGA connections. The filtering components shown should be placed close to the device and away from noise sources.

FIGURE 1-3: WFBGA CAP PIN REFERENCE AND AVSS DIRECTLY CONNECTED TO GND

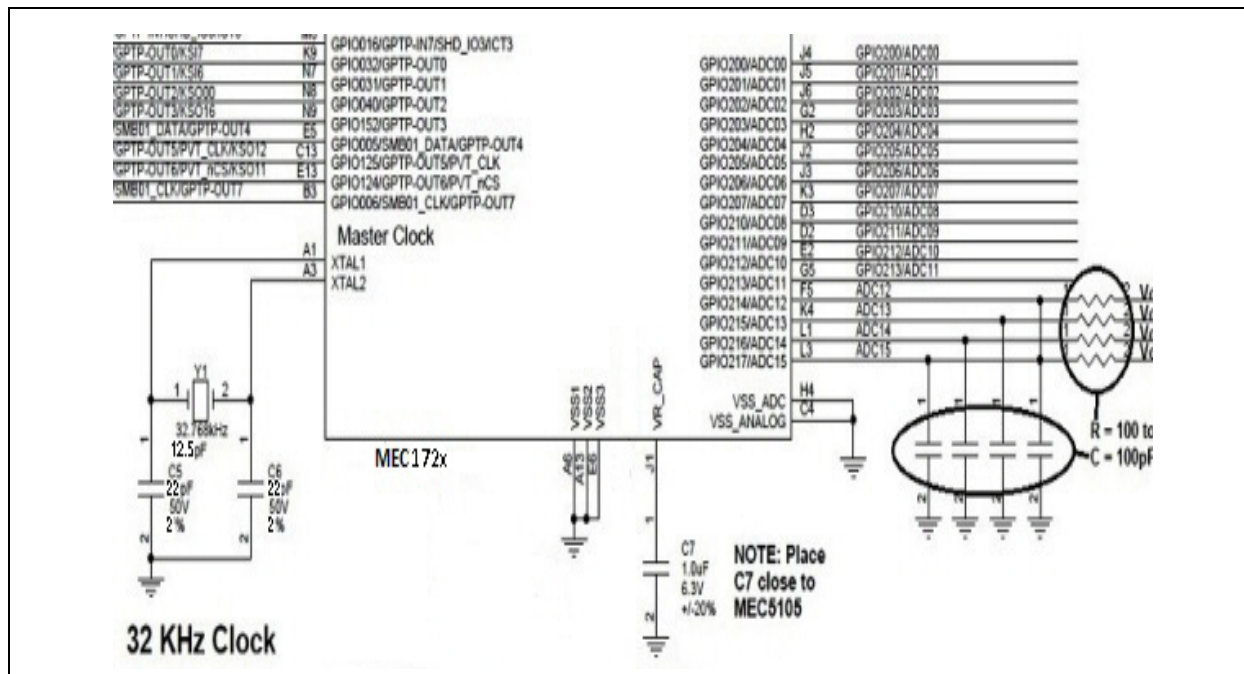

1.4 BGA Package PCB Layout Considerations

The MEC1721/MEC1723 devices have BGA RoHS-Compliant package as follows:

- 176-pin WFBGA/LJ: 11mm x 11mm, 0.8mm ball pitch (see Figure 1-4)
- 144-pin WFBGA/SZ (see Figure 1-5)

Note: Please refer to the latest data sheet for most up-to-date PCB LAND pattern information.

The following list summarizes BGA routing guidelines, but it is understood that final layout is process- dependent and your design should reflect your needs:

- Through-hole vias technology is not recommended for pitches less than 0.8mm (unless the ball matrix is depopulated in the center)
- NSMD ball pads for pitches 0.8mm – 0.4mm
- Solder Mask to be 1:1 scale of the land size, when routing 0.5mm pitch ball pads
- μ Vias – next generation PCB technology for tighter pitches
- Eliminate through-hole vias
- Increase routing density & enhance electrical performance
- Decrease routing layers
- Provide fan-out solutions for multiple layers (stacked Vias)

FIGURE 1-4: LAND PATTERN DIMENSIONS, 176-WFBGA/LJ, 0.65MM BALL PITCH

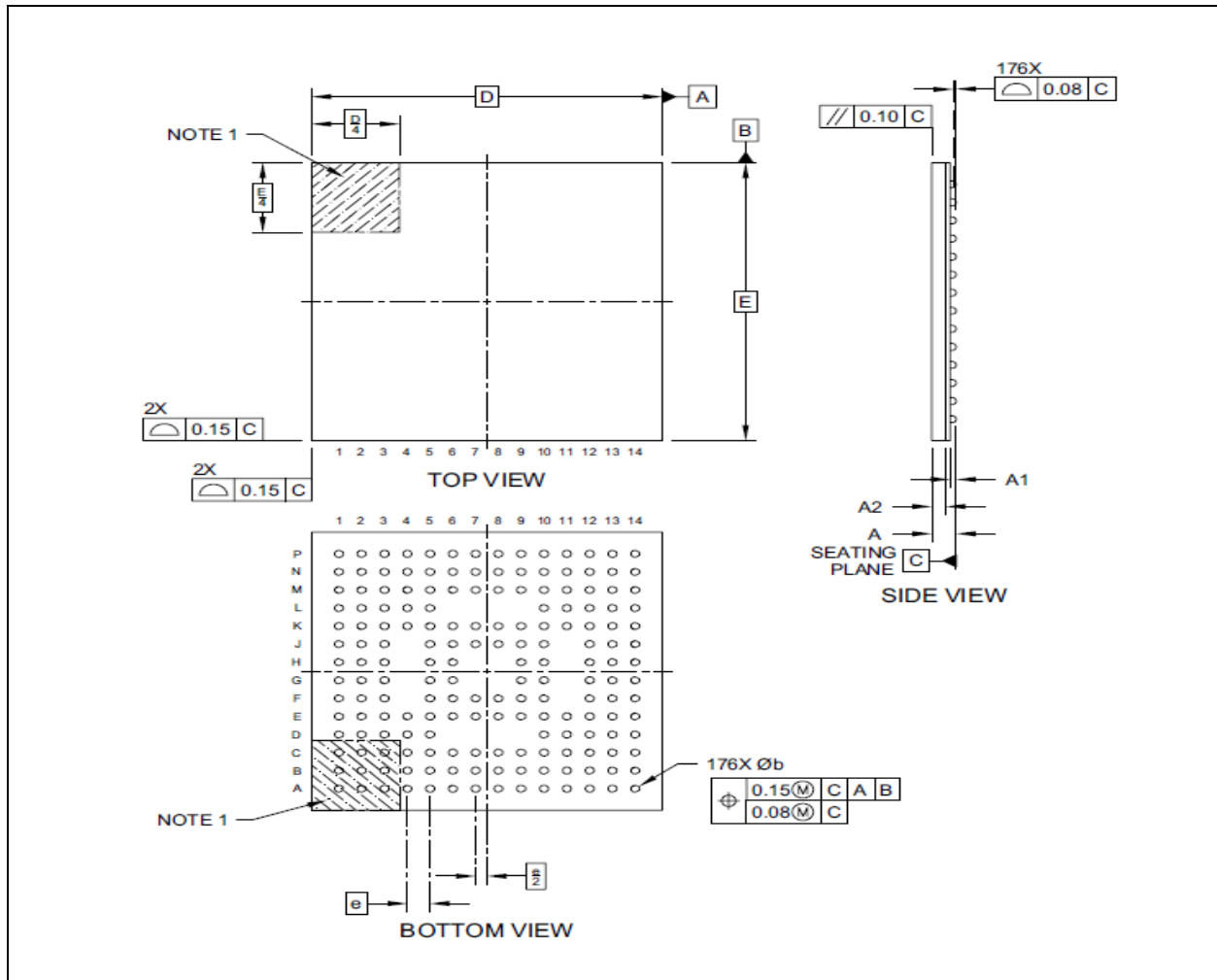

AN3759

FIGURE 1-5: LAND PATTERN DIMENSIONS, 144-WFBGA/SZ

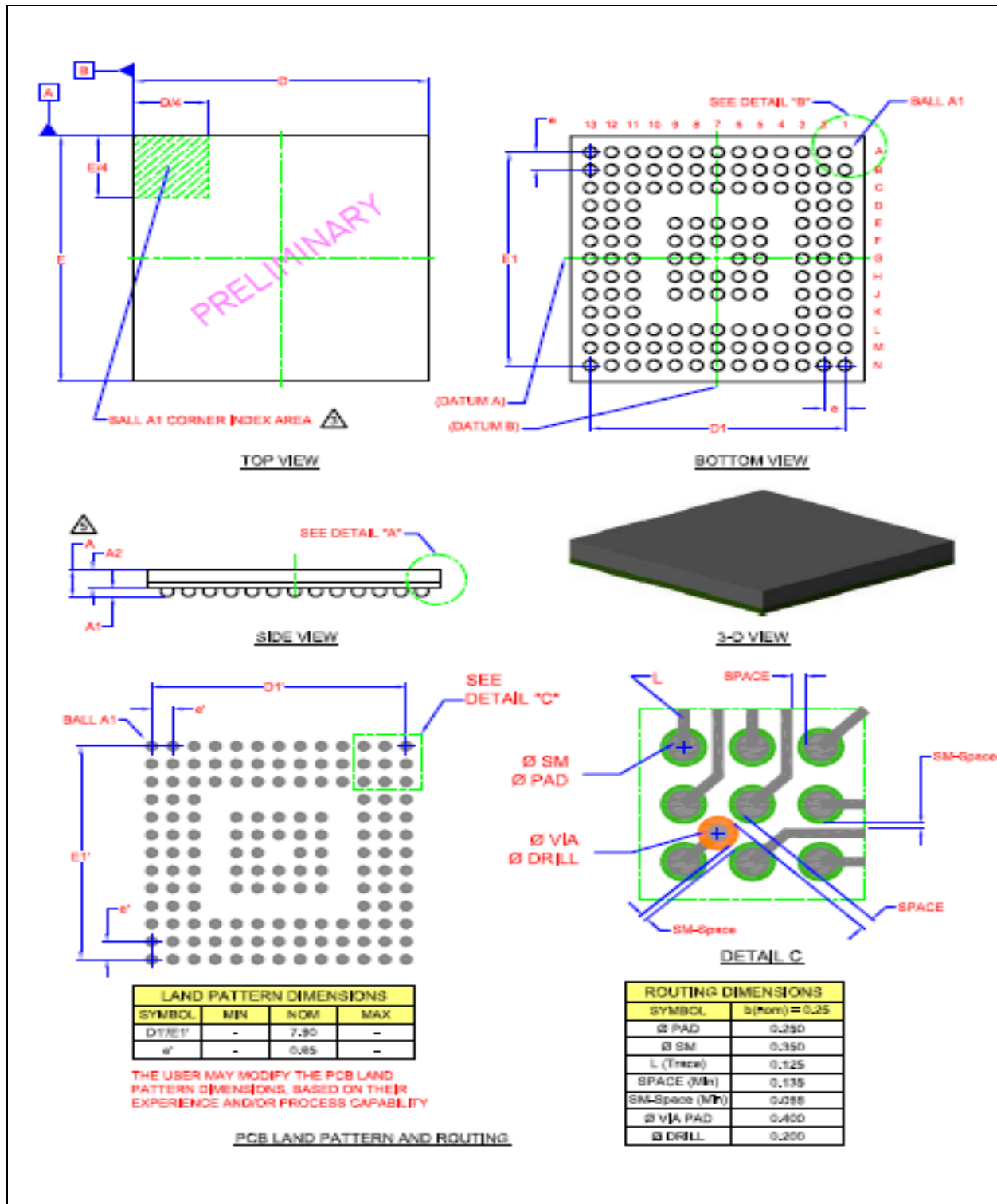

2.0 MISCELLANEOUS CONSIDERATIONS

This section covers a variety of layout topics:

- [Section 2.1, "Strapping Options," on page 9](#)
- [Section 2.2, "Battery Circuit," on page 10](#)
- [Section 2.3, "eSPI Interface," on page 10](#)
- [Section 2.4, "PS/2 Interface," on page 11](#)
- [Section 2.5, "EOS Considerations," on page 11](#)
- [Section 2.6, "ADC Input Layout Requirements," on page 12](#)
- [Section 2.7, "SPI Flash Implementation," on page 12](#)
- [Section 2.8, "1MHz Pullup Resistor Requirement," on page 19](#)
- [Section 2.9, "5V Tolerant Pins," on page 19](#)
- [Section 2.10, "1.8V Capability," on page 19](#)
- [Section 2.11, "Power Switch Input," on page 19](#)
- [Section 2.12, "VCI_IN Pins When Used as GPIO," on page 20](#)
- [Section 2.13, "VSET Pin \(MEC1725 Only\)," on page 20](#)
- [Section 2.14, "Guardian Connections \(MEC1725 Only\)," on page 20](#)
- [Section 2.15, "PECI," on page 22](#)
- [Section 2.16, "Prochot Implementation," on page 22](#)
- [Section 2.17, "MEC1721/MEC1723 Shared SPI Flash Isolation Requirement," on page 23](#)

2.1 Strapping Options

[Table 2-1](#) describes the MEC1721/MEC1723 strap option pins.

TABLE 2-1: MEC1721/MEC1723 STRAP OPTIONS

Pin Name	Strap Name	Strap Define and Value	I/O Power Rail
GPIO170	JTAG_STRAP	1=Use the JAG TAP Controller for Boundary Scan 0=The JTAG TAP Controller is used for debug (normal operation)	VTR1
GPIO045	GPIO045	Crisis Recovery Strap 1=Normal Boot Source 0=Use the Private SPI pins to boot from Crisis Recovery flash over Key scan connector Note: This pin requires an external pull-up for normal operation.	VTR1
GPIO207	CMP_STRAP	CMP_STRAP is the Comparator 0 Strap pin. This strap must be enabled in OTP. Note 3 1=Comparator 0 Enabled Note 4 0=Hardware Default (GPIO input)	VTR1
GPIO055/ SHD_CS 0#	BSS_STRAP	Boot Source Select Strap 1=Use the Shared SPI pins for Boot Note 2 0=Use the eSPI Flash Channel for Boot Note 1	VTR2
GPIO126	UART_BSTRAP	Crisis Recovery over UART 1=Normal Operation 0=Use UART interface for Crisis recovery Note 5	VTR1
GPIO227	PWRGD_STRAP	Power Good	VTR1

AN3759

Note 1: If the eSPI Flash Channel is used for booting, i.e., eSPI Master Attached Flash Sharing (MAFS), the GPIO055/PWM2/SHD_CS0# pin must be used as RSMRST#. This pin will be driven high by the boot ROM code in order to activate the eSPI flash channel. In addition, the GPIO016/GPTP_IN1/SHD_IO3/ICT3 pin must be used as DSW_PWROK. This pin will also be driven high by the boot ROM code to support Deep Sleep Well timing requirements.

- 2: If the Shared SPI port is used for booting, then any unused GPIO may be used for RSMRST#.
- 3: The comparator strap option is an optional feature that may be enabled in OTP to enable the Boot ROM to configure and lock the Comparator 0 pins. If the feature is enabled in OTP, and external pull-up/pull-down is required to determine the default comparator behavior. If the strap option is not enabled in OTP, the CMP_STRAP is not supported and no external pull-up or pull-down required. Application firmware may enable the comparator if supported by the specific package.
- 4: CMP_STRAP option is available only in the 144 pin package.
- 5: OTP byte 115 bit [3] allows selection of UART0/UART1 for Crisis Recovery, if UART_BSTRAP is enabled and sampled as 0x0.

2.2 Battery Circuit

Please see the Power Sources section of the MEC1721/MEC1723 Data Sheet.

For the battery circuitry requirement, VBAT must always be present if VTR is present. The following circuit is recommended to fulfill this requirement.

FIGURE 2-1: RECOMMENDED BATTERY CIRCUIT

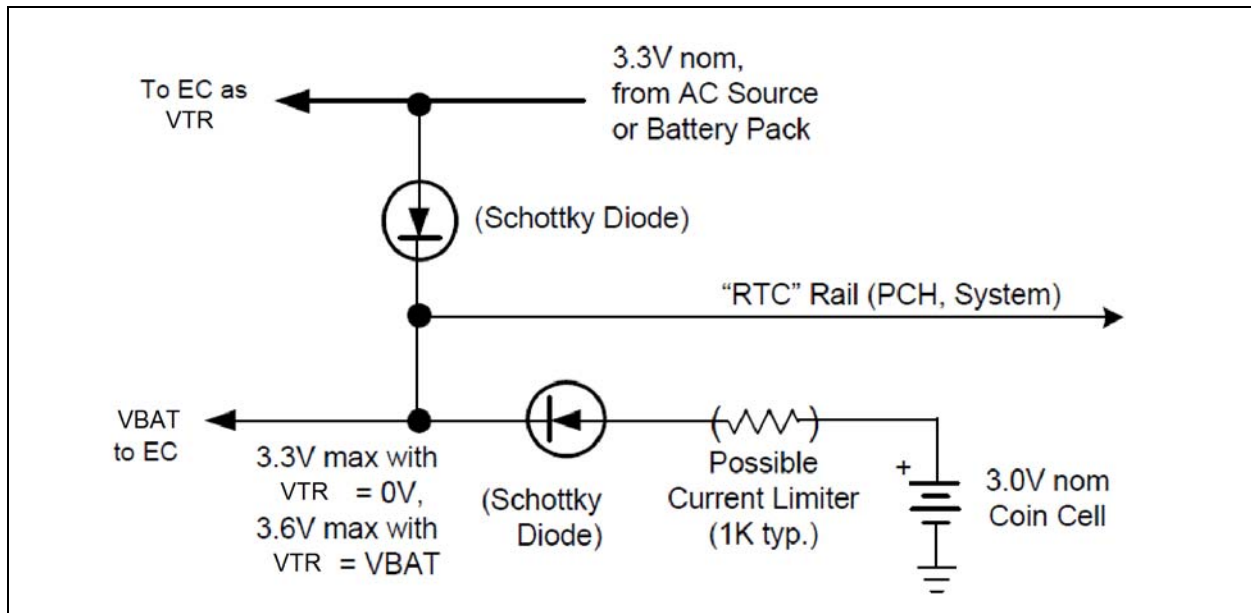

2.3 eSPI Interface

The firmware must configure the GPIO Pin Control Registers for the eSPI alternate function, configure the eSPI I/O Component Base Address Register, and activate the eSPI block.

2.3.1 VTRX POWER PIN

The eSPI Interface signals require the VTR3 power pin to be connected to the 1.8V rail.

2.3.2 HOST RESET SELECT

The platform reset signal that will be used to assert nSIO_RSET is determined by the POWER RESET CONTROL Register (40080114h) Bit 8 = 0 - eSPI_PLTRST# pin.

2.3.3 OTHER SIGNALS

All the eSPI I/F signals are connected to other eSPI signals that are already present in the system. The MEC1721/MEC1723 use 1.8V signaling for all eSPI signals. Please refer to the Intel Skylake Ultrabook Platform U-Series RVP Customer Reference Board Schematic, Microchip MEC1721/MEC1723 Evaluation Board Schematic, and reworks instruction for detailed information.

Note a few design notes below:

- LPC_AD0_ESPI_IO0, LPC_AD1_ESPI_IO1, LPC_AD2_ESPI_IO2, LPC_AD3_ESPI_IO3, LPC_-FRAME_ESPI_CS#, and LPC_CLK_0_ESPI_CLK signals have 15 ohm series resistor close to each chipset pin and another 15 ohm series resistor close to the MEC1721/MEC1723 for eSPI mode.
- GPP_C5/SML0ALERT# (Intel Skylake chipset pin W1) is used as strapping pin to determine either LPC mode (Low) or eSPI mode (High).

2.4 PS/2 Interface

The routing of the PS/2 interface is also not critical, except that it should not be routed next to rapidly switching signals. The Clock and Data pins are Open Drain and require pullup resistors. A small 10 - 100pF (typ) capacitor to ground and 4.7k Ω (typ) pullups are recommended. The power pin of the PS/2 pin should be decoupled with a capacitor that is large enough to adequately filter the supply to PS/2 devices. Unused PS/2 clock and data pins should be pulled up to VCC with a 10k Ω (typ) resistor.

Note: Two PS/2 ports are 5V tolerant when in 3.3V mode. The other three PS/2 ports are not.

2.5 EOS Considerations

For SMBus signals that terminate external to the main system board (for example, Smart Battery) the designer should take care in protecting these signals from EOS (Note 2-1) and ESD (Note 2-2). Please refer to the SMBus 2.0 specification, section 3.1.2.2 for appropriate guidelines. The specification recommends a series protection resistor and an optional ESD transorb on these nets. In addition to the SMBus specification recommendation, past experience shows that using 2 high speed diodes on each SMBus trace (instead of the transorb in the SMBus spec) is an effective way to improve immunity to EOS and ESD events. A Schottky diode pair is a good example. Figure 2-2 shows the suggested circuit implementation for each net that goes to a connector.

FIGURE 2-2: SCHOTTKY DIODE PAIR EXAMPLE

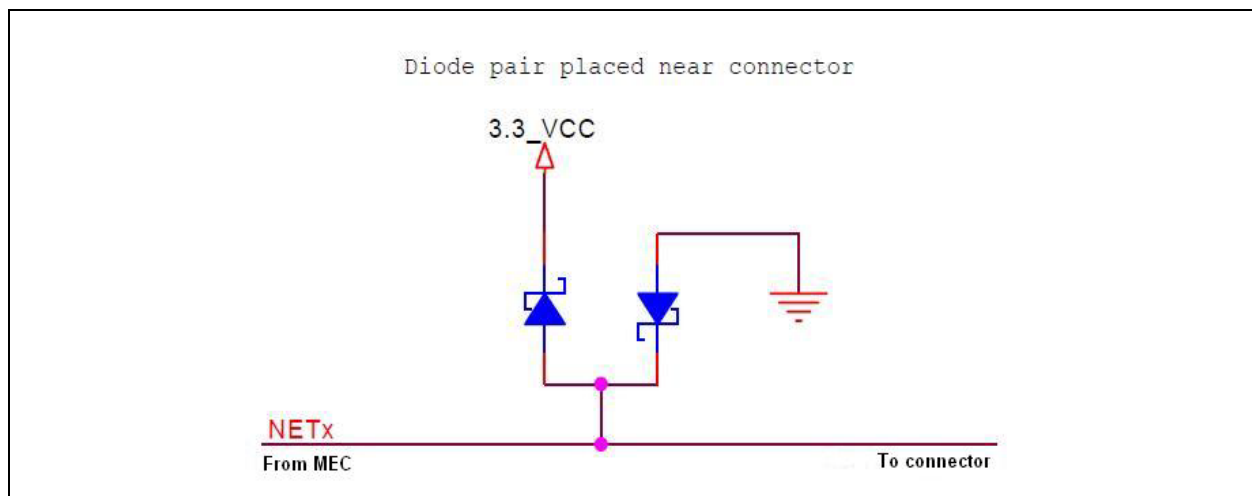

It should also be noted that any other signal that goes to an external connector should also be considered for EOS/ESD susceptibility. For instance, an ID pin (tied to a GPIO) that might seem benign, but is routed near high voltage sources could suffer transient EOS events. A similar protection scheme should be considered for these nets.

Note 2-1 EOS is defined as damage to the part caused by the application of voltages (to any pin) beyond the power supply rails, usually forward biasing internal protection diodes and resulting in high levels of

AN3759

current flow. This typically induces open failures by damaging the metal inside the part. EOS is typically a low voltage, high current situation.

Note 2-2 ESD is the applied reverse bias to the PN junction -- heat due to power dissipation melts the silicon in the part. ESD is typically a high transient voltage spike with low current situation.

2.6 ADC Input Layout Requirements

- It is suggested that the Analog-Digital Converter (ADC) Source AVSS reference connects to the MEC1721/MEC1723 AVSS via a low noise AVSS island, which is shown in [Figure 1-3](#).
- It is suggested that a low pass filter, see [Figure 2-3](#), be used on each ADC input of MEC1721/MEC1723. Filter components below are a good starting point, the R should have value between 100 ohm to 1.1 kohm and the C should have value between 100pF to 2500pF. The RC values are based on high frequency cut off desired for the application, $F = 1 / (2\pi * RC)$.

FIGURE 2-3: ADC INPUT LOW PASS FILTER

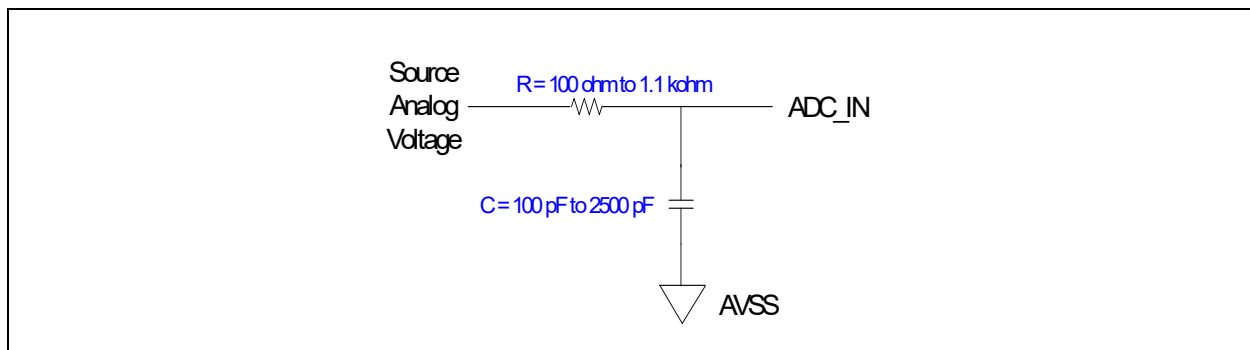

- It is recommended that the ADC nets are spaced at least 20 mils from any high speed switching signals to prevent cross talk that could add noise.

2.7 SPI Flash Implementation

The MEC1721/MEC1723 SPI flash interface enables the host and embedded controller (EC) access to an external SPI flash device. The MEC1721/MEC1723 Data Sheet and Boot ROM Application Note have more details on detail information (see [References on page 1](#)). This section describes specific PCB layout design considerations to setup this feature.

Note: The SPI Flash Interface of MEC1721/MEC1723 can be selected either 3.3V or 1.8V. The SHD SPI interface is on VTR2 power rail, and PVT SPI interface is on VTR1 power rail.

The standard set of SPI flash signals are designated with "SHD_" for shared connections, for example, SHD_CLK; for details, see [Section 2.7.3, "Shared SPI Flash Interface"](#). MEC1721/MEC1723 has an added set of signals for connection to another SPI flash device as private, protected data; these signals are designated with "PVT_" for example, PVT_CLK; for details, see [Section 2.7.4, "Non-shared SPI Flash Interface"](#). The MEC1721/MEC1723 has a third SPI interface as a general SPI interface labeled as "SPI_" for example, SPI_CLK.

TABLE 2-2: SPI INTERFACE SIGNALS

Generic Pin Signal Name	Pin Signal Function Name	MEC1721/MEC1723 Pin Number	Pin Function Signal Description
SPICLK	SHD_CLK	N7	Shared SPI Clock
	PVT_CLK	E12	Private SPI Clock
SPI_CS#	SHD_CS0#	P5/P8	Shared SPI Chip Selects
	PVT_CS#	G12	Private SPI Chip Selects

TABLE 2-2: SPI INTERFACE SIGNALS (CONTINUED)

Generic Pin Signal Name	Pin Signal Function Name	MEC1721/MEC1723 Pin Number	Pin Function Signal Description
IO0 / MOSI	SHD_IO0 / SHD_MOSI	P6	Shared SPI Data I/O 0.
	PVT_IO0 / PVT_MOSI	H12	Private SPI Data I/O 0.
	Note: Also used as SPI_MOSI when the interface is used in single wire mode.		
IO1 / MISO	SHD_IO1 / SHD_MISO	M7	Shared SPI Data I/O 1.
	PVT_IO1 / PVT_MISO	F12	Private SPI Data I/O 1.
	Note: Also used as SPI_MISO when the interface is used in single wire mode.		
IO2	SHD_IO2	N6	Shared SPI Data I/O 2
	PVT_IO2	G13	Private SPI Data I/O 2
	Note: Only used in Quad Mode. Also can be used by firmware as WP.		
IO3	SHD_IO3	N5	Shared SPI Data I/O 3
	PVT_IO3	E13	Private SPI Data I/O 3
	Note: Only used in Quad Mode. Also can be used by firmware as HOLD.		

2.7.1 SELECTION OF SPI PORT & RSMRST#

The MEC1721/MEC1723 Boot ROM firmware selects two potential sources, the Shared SPI port or the eSPI Flash Channel, from which to load the application firmware. The selection is done by sampling the BSS_STRAP pin.

When used with a PC-based core logic, the EC must supply the RSMRST# signal to the core. If the eSPI Flash Channel is used as the source for EC firmware, the **BSS_STRAP pin MUST be used as the RSMRST# signal**. A weak-pulldown resistor to ground must be connected to the pin as shown in [Figure 2-4](#). The pull-down both holds RSMRST# low glitch-free during the power-on sequence, as required by the core logic, and informs the Boot ROM in the MEC1721/MEC1723 to use the eSPI Flash Channel.

FIGURE 2-4: MEC1721/MEC1723 SHARED SPI FLASH DEVICE THRU ESPI FLASH CHANNEL

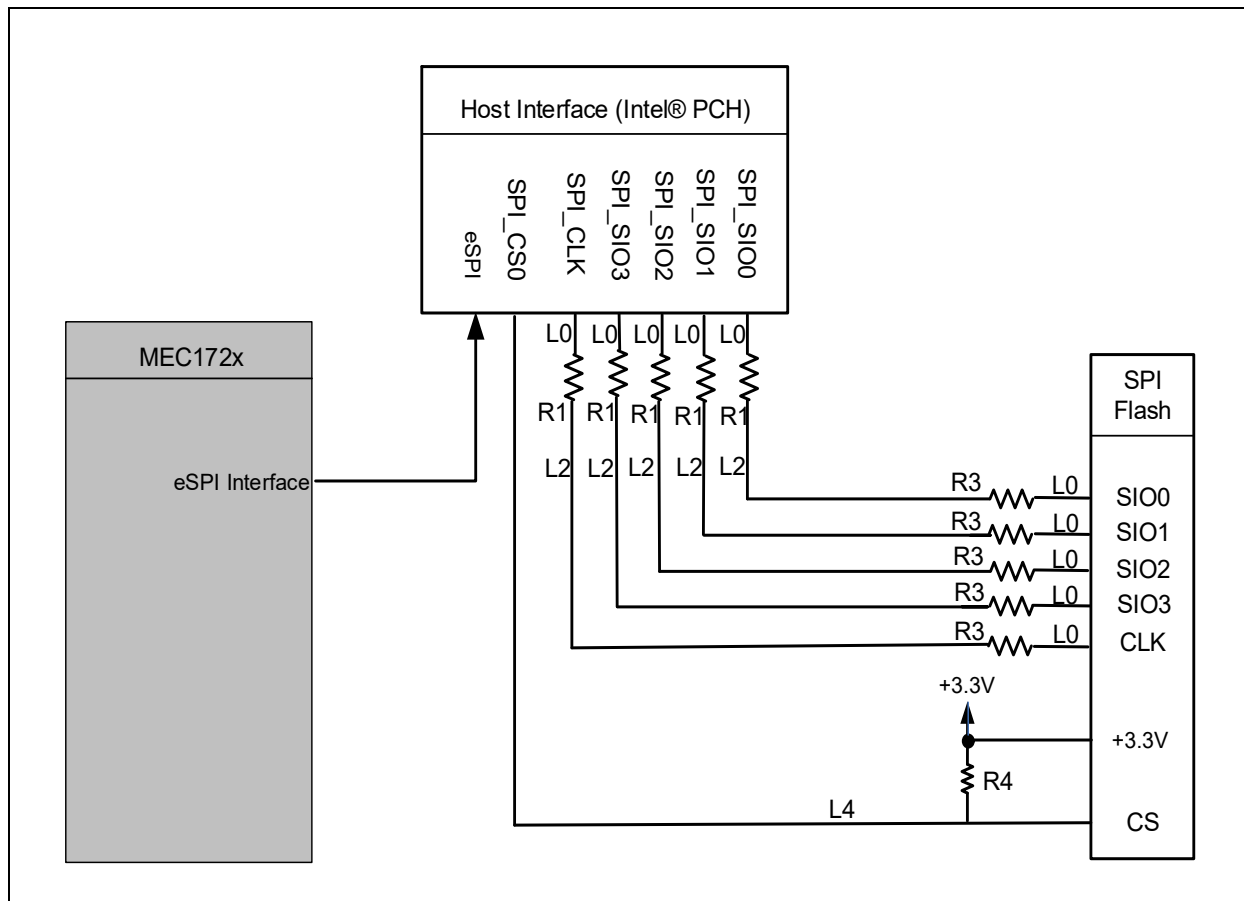

Note: For the required components and values that need to be used to connect between the Core Logic & external SPI flash, please refer to the corresponding core logic design guidelines and documentation for reference. The Figure 2-4 is used for illustration purpose only.

If the EC firmware is sourced from an external SPI Flash device directly to the Shared SPI Flash interface, **the BSS_STRAP pin MUST NOT be used as the RSMRST# signal**. Any other GPIO can serve as RSMRST#, if connected to ground with a weak pull-down resistor as shown in Figure 2-5. Once firmware is loaded and executed, it can release RSMRST# by setting the selected GPIO high.

2.7.2 SHARED VS. NON-SHARED SPI IMPLEMENTATION

Section 2.7.3, "Shared SPI Flash Interface" describes implementing the SPI Flash Interface using the shared signals (for example, SHD_CLK); Section 2.7.4, "Non-shared SPI Flash Interface" describes implementing the SPI Flash Interface using private signals (for example, PVT_CLK).

See Section 2.7.4, "Non-shared SPI Flash Interface," on page 16 for further details of this setup.

2.7.3 SHARED SPI FLASH INTERFACE

2.7.3.1 Shared SPI Flash Implementation

Figure 2-5 is a topology for implementing a single MEC1721/MEC1723 SPI flash for shared SPI flash devices. See Table 2-3 for specifications on PCB trace recommendations represented by “L1,” “L2,” and so forth.

FIGURE 2-5: MEC1721/MEC1723 SHARED SPI FLASH DEVICE THRU SHD SPI INTERFACE

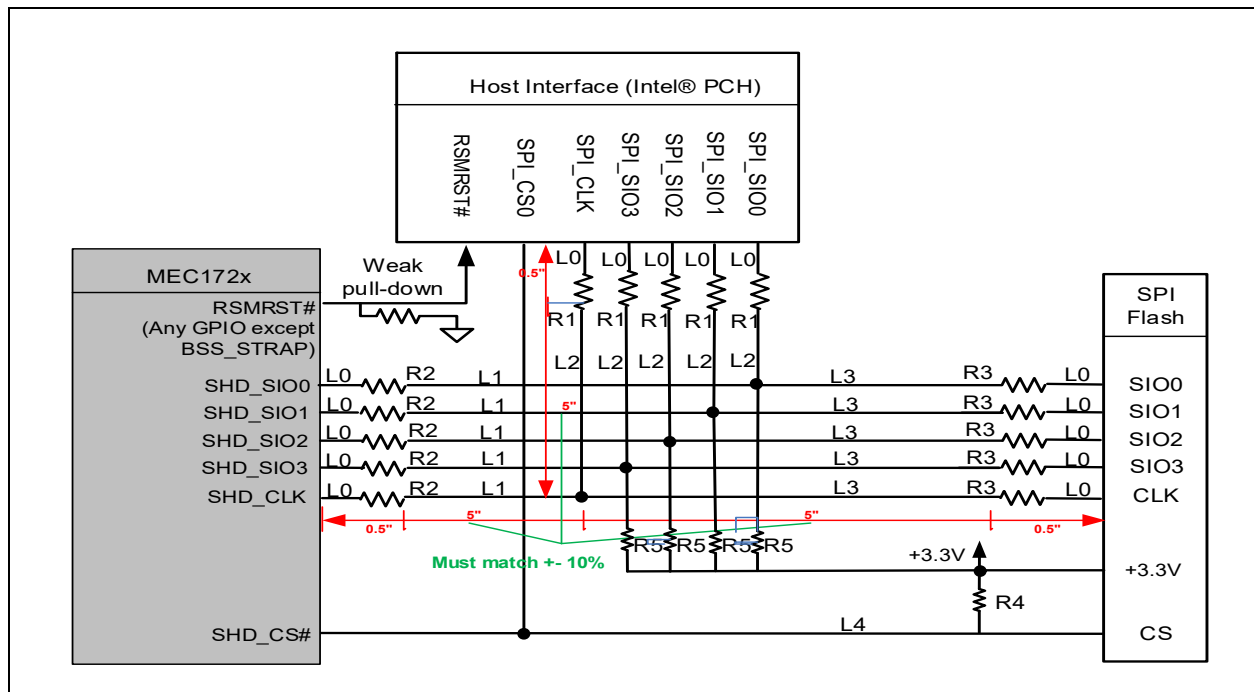

TABLE 2-3: MEC1721/MEC1723 SHARED SPI FLASH DEVICE SPECIFICATIONS (3.3V OR 1.8V, 24MA DRIVERS AT 48MHZ)

	Description	Spec
L0	Connection between MEC1721/MEC1723, Host/PCH, or SPI flash device and termination resistors.	0.1-inch to 0.5-inch
L1	PCB trace from the MEC1721/MEC1723 termination resistor to the PCB trace connection from the SPI flash and Host/PCH.	L1 = L2 = L3 within +/- 10% These trace connections can equal 1-inch up to 5-inches. See Note 2-5 .
L2	PCB trace from the Host/PCH termination resistor to the PCB trace connection from the SPI flash and MEC1721/MEC1723.	
L3	PCB trace from the SPI flash termination resistor to the PCB trace connection from the MEC1721/MEC1723 or Host/PCH.	
L4	PCB trace from Host/PCH or MEC1721/MEC1723 to SPI flash for chip select.	L4 = L1 + L3 + (2 x L0) or L4 = L2 + L3 + (2 x L0) +/- 0.100 inches.
R1	These resistors are between the PCB trace and the Host/PCH.	3.3V - 35 ohm 1.8V - 20 ohm See Note 2-3 , Note 2-4 .
R2	These resistors are between the PCB trace and the MEC1721/MEC1723.	3.3V - 10 ohm; 1.8V - 2.5 ohm See Note 2-3 , Note 2-4 .
R3	These resistors are between the PCB trace and the SPI flash.	3.3V - 2.5 ohm; 1.8V - 0 ohm See Note 2-3 , Note 2-4 .
R4	Pull-high resistor to +3.3V for SPI CS connections; between the MEC1721/MEC1723 or Host/PCH and the SPI flash device. This pull-high must connect to the same power rail of the SPI flash.	2.2K ohm

AN3759

TABLE 2-3: MEC1721/MEC1723 SHARED SPI FLASH DEVICE SPECIFICATIONS (3.3V OR 1.8V, 24MA DRIVERS AT 48MHZ) (CONTINUED)

	Description	Spec
R5	Pull-high resistor to +3.3V for SPI IO0/IO1/IO2/IO3 data bus connections, between the MEC1721/MEC1723 or Host/PCH and the SPI flash device, and close to connection of L1, L2 & L3 traces. This pull-high must connect to the same power rail of the SPI flash.	4.7K ohm

Note 2-3 The final value of the series resistors should be chosen based on performing electrical analysis to ensure the electrical timings and min/max voltage specifications are met for each device (SPI, EC, PCH or other Host SPI controller) including the undershoot/ overshoot specifications for the MEC1721/MEC1723 (-0.3V min. to $V_{CC1}+0.3V$ max).

Note 2-4 Resistor recommendations are based on testing with Cannon Lake Server PCH IBIS model and Winbond SPI flash IBIS model w/ proper drivers in the system design.

Note 2-5 L1, L2, L3 must be equal to each other. For example, if L1 = 2-inches, then L3 must be 2-inches.

2.7.4 NON-SHARED SPI FLASH INTERFACE

Note: Either Shared SPI or SAFS (Slave Attached Flash Sharing) interface can support a dedicated SPI chip.

2.7.4.1 Non-Shared Single SPI Flash Implementation (3.3V @ 16mA or 1.8V @ 24mA at 96MHz)

Figure 2-6 is a topology for implementing the MEC1721/MEC1723 SPI flash for a single non-shared SPI flash device. See Table 2-4 for specifications on PCB trace recommendations represented by "L1," "L2," and so forth.

FIGURE 2-6: MEC1721/MEC1723 TOPOLOGY FOR NON-SHARED SPI FLASH DEVICE

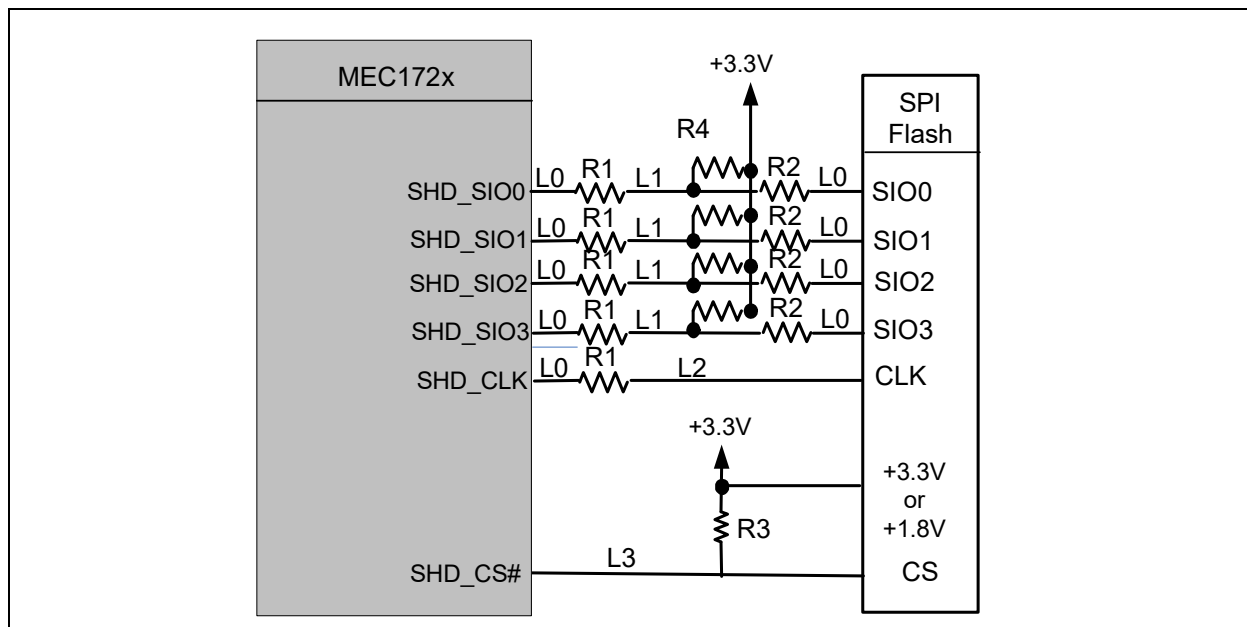

TABLE 2-4: MEC1721/MEC1723 NON-SHARED SPI FLASH DEVICE SPECIFICATIONS

	Description	Spec
L0	Connection between MEC1721/MEC1723 or SPI flash device and termination resistors.	0.1-inch to 0.5-inch
L1	The PCB trace between terminating resistors on the IO lines.	1-inch to 10-inch
L2	The PCB trace from MEC1721/MEC1723 or R1 resistor to SPI flash.	1-inch to 10-inch

TABLE 2-4: MEC1721/MEC1723 NON-SHARED SPI FLASH DEVICE SPECIFICATIONS

	Description	Spec
L3	PCB trace from MEC1721/MEC1723 to SPI flash for chip select.	$L3 = L0 + L1$
R1	These resistors are between the trace and the MEC1721/MEC1723.	3.3V - 45 ohm; 1.8V - 40 ohm, see also Note 2-6
R2	This resistor is on the IO lines between the SPI flash and trace.	3.3V - 2.5 ohm; 1.8V - 7.5 ohm, see Note 2-6 .
R3	This is a Pull-High resistor (to +3.3V) for SPI CS connections. This pull-high must connect to the same power rail of the SPI flash.	2.2K ohm
R4	Pull-high resistor to +3.3V for SPI IO0/IO1/IO2/IO3 data bus connections, between the MEC1721/MEC1723 and the SPI flash device, and close to mid-point of L1 traces. This pull-high must connect to the same power rail of the SPI flash.	4.7K ohm

Note 2-6 The final value of the series resistors should be chosen based on performing electrical analysis to ensure the electrical timings and min/max voltage specifications are met for each device (SPI, EC, PCH or other Host SPI controller) including the undershoot/ overshoot specifications for the MEC1721/MEC1723 (-0.3V min. to $V_{CC1} + 0.3V$ max).

2.7.4.2 Non-Shared Dual SPI Flashes Implementation (3.3V @ 16mA or 1.8V @ 24mA at 48MHz)

Figure 2-6 is a topology for implementing the MEC1721/MEC1723 SPI flash for a single non-shared SPI flash device. See Table 2-4 for specifications on PCB trace recommendations represented by "L1," "L2," and so forth.

FIGURE 2-7: MEC1721/MEC1723 TOPOLOGY FOR NON-SHARED DUAL SPI FLASH DEVICE

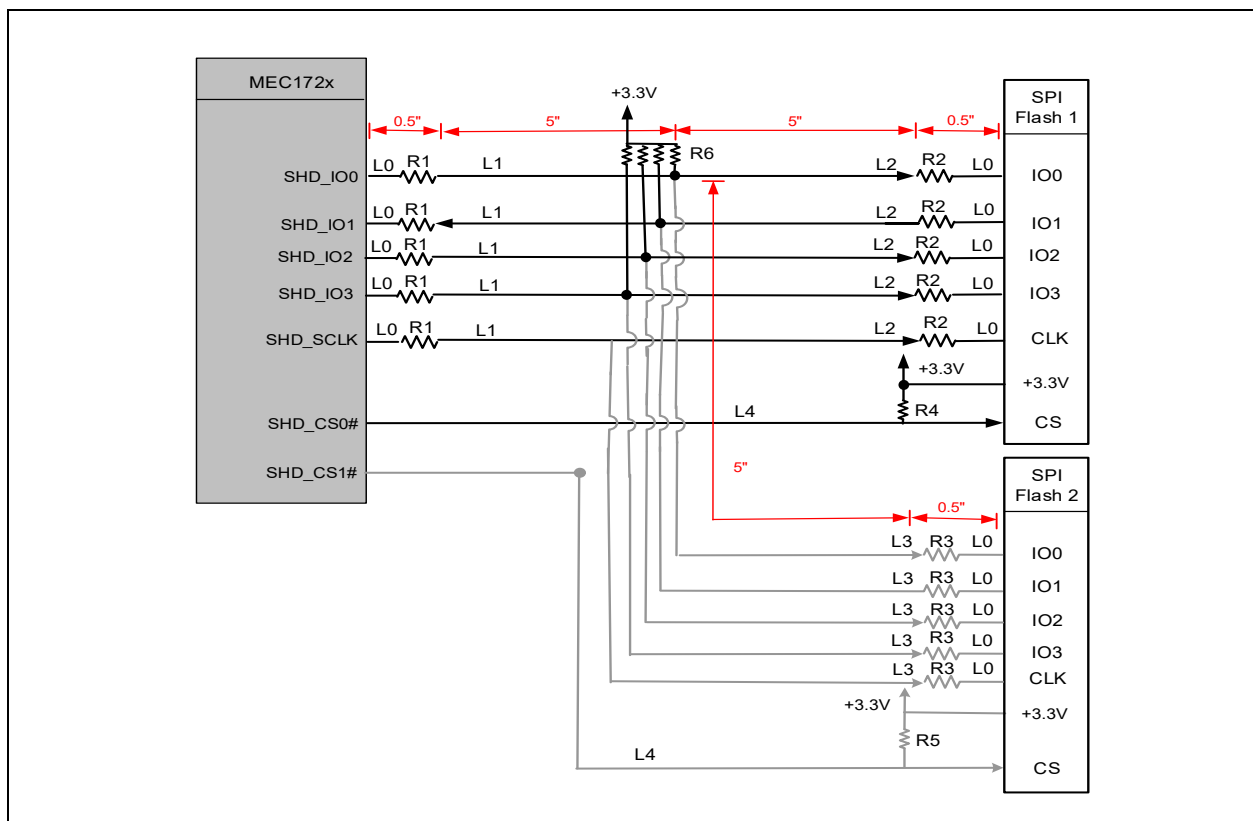

TABLE 2-5: MEC1721/MEC1723 NON-SHARED DUAL SPI FLASH DEVICE SPECIFICATIONS

	Description	Spec
L0	Connection between MEC1721/MEC1723, 2 SPI flash devices and termination resistors.	0.1-inch to 0.5-inch
L1	PCB trace from the MEC1721/MEC1723 termination resistor to the PCB trace connection from 2 SPI flash devices.	L1 = L2 = L3 within +/- 10% These trace connections can equal 1-inch up to 5-inches. See Note 2-5 .
L2	PCB trace from the first SPI Flash termination resistor to the PCB trace connection from the second SPI flash and MEC1721/MEC1723.	
L3	PCB trace from the second SPI flash termination resistor to the PCB trace connection from the MEC1721/MEC1723 and the first SPI flash.	
L4	PCB trace from MEC1721/MEC1723 to the dual SPI flash for chip select.	L4 = L1 + L3 + (2 x L0) or L4 = L2 + L3 + (2 x L0) +/- 0.100 inches.
R1	These resistors are between the PCB trace and the MEC1721/MEC1723.	3.3V - 35 ohm 1.8V - 20 ohm See Note 2-7 .
R2	These resistors are between the PCB trace and the first SPI flash.	3.3V - 10 ohm; 1.8V - 2.5 ohm See Note 2-7 .
R3	These resistors are between the PCB trace and the second SPI flash.	3.3V - 2.5 ohm; 1.8V - 0 ohm See Note 2-7
R4/R5	This is a Pull-High resistor (to +3.3V) for SPI CS connections. This pull-high must connect to the same power rail of the SPI flash.	2.2K ohm
R6	Pull-high resistor to +3.3V for SPI IO0/IO1/IO2/IO3 data bus connections, between the MEC1721/MEC1723 or Host/PCH and the SPI flash devices, and close to connection of L1, L2 & L3 traces. This pull-high must connect to the same power rail of the SPI flash.	4.7K ohm

Note 2-7 The final value of the series resistors should be chosen based on performing electrical analysis to ensure the electrical timings and min/max voltage specifications are met for each device (SPI, EC, PCH or other Host SPI controller) including the undershoot/ overshoot specifications for the MEC1721/MEC1723 (-0.3V min. to $V_{CC1} + 0.3V$ max).

2.7.5 SPI FLASH IMPLEMENTATION RECOMMENDATIONS

The following recommendations are for both Shared and Non-Shared SPI Flash Implementations.

- The MEC1721/MEC1723 SPI memory interface has serial flash device compatibility requirements that are defined in the MEC1721/MEC1723 Data Sheet. Please make sure the selected SPI flash meets these requirements.
- SPI_CLK must be 20mils spacing from any other high frequency (>1GHz) signal.
- The SPI flash parts should support operating at 12MHz for the ROM code loader, and up to 48MHz clock speed in RAM code loading.
- The designer should follow the SPI interface host design guidelines.
- IBIS models are available to aid in simulating the SPI system topology.
- The chip select CS# signals should have weak pullup resistors to the same power rail as the SPI flash. The pullup resistor value should meet the rise time requirements of the SPI flash.
- EC firmware must configure the MEC1721/MEC1723 SPI memory interface to disable mode, which will tri-state the SPI memory interface from MEC1721/MEC1723 to the SPI flash, before releasing the RSMRST# signal.
- This configuration requires that the PCH tri-state its SPI flash pins when RSMRST# is asserted.
- The characteristic impedance of the PCB trace should be 50 ohms +/-15% at 50MHz operating frequency.
- Within the SPI flash device, Schmitt trigger inputs are assumed on both the clock line and IO data lines.
- Within the Intel PCH, a Schmitt trigger input is assumed on the IO data lines.
- The output drivers for the SPI flash chip select pins should be programmed as open-drain using the GPIO Pin Control registers.

- The SPI Data IO traces should be length-matched to the CLK lines within 0.100-inch.
- Signal Integrity should be checked for each SPI part on your BOM.

2.7.6 SPI FLASH EXTERNAL PROGRAMMER

The SPI Flash on either Shared or Non-Shared SPI Flash interface must be programmed externally using a suitable programmer, such as Dediprog's SF100 (<http://www.dediprog.com/pd/spi-flash-solution/sf100>).

Provisions for a programming header on each SPI flash are recommended if the SPI is not socketed.

2.8 1MHz Pullup Resistor Requirement

Please refer to the I²C-bus specification and user manual as indicated in the section [References on page 1](#) for more information.

2.9 5V Tolerant Pins

There are fourteen 3.3V/5V tolerant pins on the MEC1721/MEC1723. Please see the MEC1721/MEC1723 Data Sheet section 2.5.7 for more information.

2.10 1.8V Capability

There are three voltage supply regions for all GPIO pins powered by VTR1, VTR2, and VTR3. Each region may be either 3.3V or 1.8V. Please refer to the MEC1721/MEC1723 Data Sheet section 2 for more information.

Note: The LPC Interface Signals require the VTR3 power pin to be connected to the 3.3V or 1.8V VTR rail. The eSPI Interface signals require the VTR3 power pin to be connected to the 1.8V rail.

2.11 Power Switch Input

For the VBAT-powered power switch inputs (VCI_INx#) there is a specific requirement for the input circuit as illustrated in [Figure 2-8](#). The resistors can use any typical 1/10W, +/- 1% carbon, thick, metal, or thin film. The capacitors can use any typical 16V 10% ceramic. Unused VCI pins should be pulled up to VBAT via a 100K resistor. Please refer to the MEC1721/MEC1723 EVB Schematics and Bill of Materials.

FIGURE 2-8: VBAT-POWERED CONTROL INPUT CIRCUIT

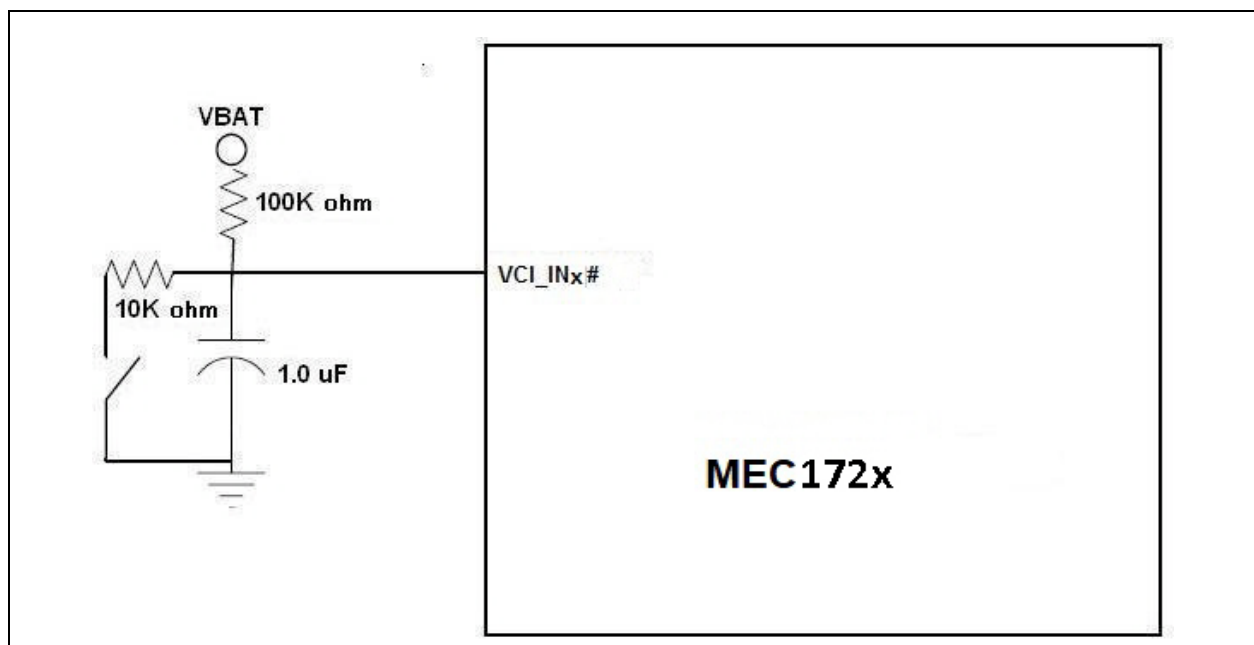

AN3759

2.12 VCI_IN Pins When Used as GPIO

All the VCI_IN pins can be used as GPIOs. The firmware must program the VCI_BUFFER_EN bit[6:0] at VCI Buffer Enable Register to disable power up functionality on these VCI pins if these are used as GPIOs.

2.13 VSET Pin (MEC1725 Only)

The MEC1721/MEC1723 VSET pin is an input to the ThermTrip block which sets the ThermTrip shutdown temperature. The system designer creates a voltage level at these input through a resistor connected to GND as shown in [Figure 2-9](#). The value of this resistor is used to create an input voltage on the TRIP_SET pin that is translated into a temperature ranging from 60°C to 123°C; see the VSET Resistor Settings table in the MEC1721/MEC1723 PCS for these values (see your Microchip representative for availability).

Note 1: VSET is designed to operate using a 1% resistor. If a 5% resistor is used, the decoded temperature may have an error more than 1°C.

2: An open condition on the VSET pin is decoded as a minimum temperature threshold level.

FIGURE 2-9: VSET CIRCUIT

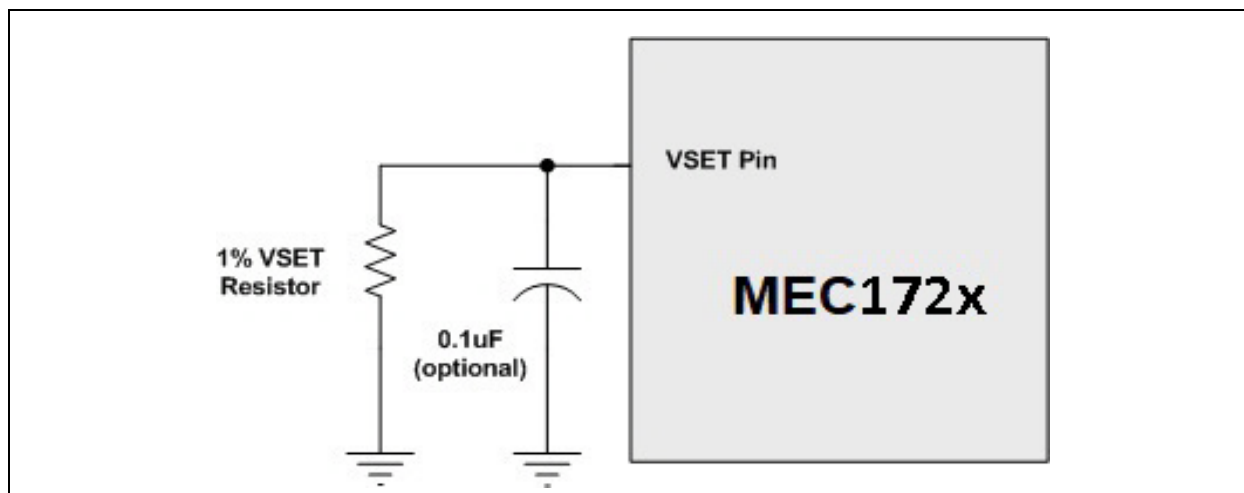

2.14 Guardian Connections (MEC1725 Only)

The Guardian block is a combination temperature sensor, voltage monitor, hardware set thermal monitor, and fan controller. It monitors one internal diode and four external diodes. Details for this block are included in the MEC1721/MEC1723 Data Sheet (or PCS). This section includes describes layout considerations for this feature.

2.14.1 THERMAL DIODE LAYOUT CONSIDERATIONS

2.14.1.1 Remote Diode Hardware Considerations

- The remote diode positive (+) and negative (-) tracks should be kept close together (a 10 mil track minimum width and spacing is recommended), in addition a separation of the diode traces from any other trace by at least a 20 mil spacing is recommended.
- Place a capacitor between the two leads, as close as possible to the MEC1721/MEC1723 chip. 470pF (beta enabled) is used for the processor diode and 2200pF (beta disabled) is used for the 3904 diode.
- Both remote temperature sensor channel inputs should be terminated with a thermal diode, a transistor or resistor, even if they are not used in the design. Transistors that are suitable for use are MMBT3904 or an equivalent. Termination resistor values for use can be from 510 ohm to 1K ohm, see [Figure •](#) and [Table 2-6](#) for generated temperature values for selected resistors.

FIGURE 2-10: UNUSED DIODE PIN CONNECTION

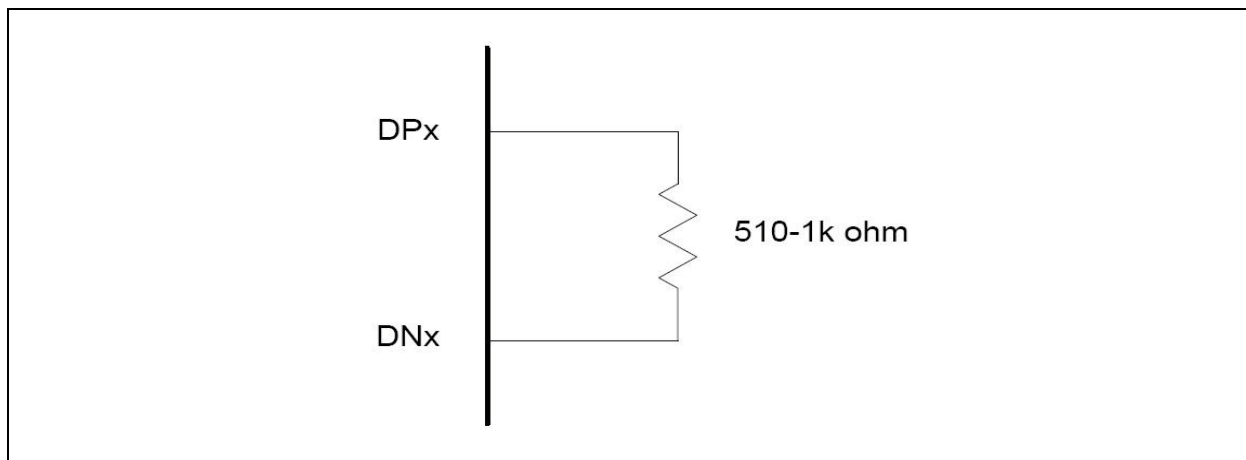

TABLE 2-6: TERMINATION RESISTOR VALUES FOR USE WITH THERMAL DIODE INPUTS

Value of Resistor between DPx and DNx	Nominal Temperature Value Generated
510 Ω	-121°C
680 Ω	-69°C
820 Ω	+33°C
1K Ω	+83°C

2.14.1.2 Thermal Diode Configuration

This section provides information on the recommended values for the filter capacitor placed across the thermal diode lines in order to use MEC1721/MEC1723 with various thermal diodes including CPU diodes, GPU diodes, and diode-connected devices such as a discrete 2N3904 device.

TABLE 2-7: TEMPERATURE SENSOR CONFIGURATION

Thermal Diode	MAX. Filter Capacitor	Recommended Filter Capacitor
Intel Processor Diode	up to 2200pF +/- 20%	470pF +/- 20%
AMD Processor Diode	up to 2200pF +/- 20%	470pF +/- 20%
nVIDIA GPU Diode	up to 2200pF +/- 20%	470pF +/- 20%
2N3904	up to 2200pF +/- 20%	2200pF +/- 20%

2.14.1.3 Noise Filter Capacitor Recommendation

Microchip recommends adding an optional footprint for a 100pF filter capacitor directly across the diode, which would only be populated if noise on each diode channel needs to be reduced.

2.14.2 ADC/THERMISTOR SUPPORT ON EXTERNAL DIODE LINES

To allow a longer trace run to the CPU well, the Guardian can also use a thermistor as a critical shutdown thermal sensor. The resistor/thermistor divider voltage is driven out on selected DP/DN channels when a measurement is made, and the voltage measurement is made on DN channel. This reading can be capacitively filtered with a 0.1 μ F capacitor; the results are very immune to noise.

Note: When configured to measure a thermistor on the External Diode channel, it is your responsibility to set the VSET voltage (see [Section 2.12, "VCI_IN Pins When Used as GPIO," on page 20](#)) to an appropriate level to emulate the desired threshold temperature. The Guardian will perform no calculations to translate the VSET voltage to an equivalent thermistor voltage. In addition, high and low limit comparisons are not changed so you should set these limits to the appropriate values.

AN3759

2.15 PECI

The PECI Interface core logic is powered by VTR1; the physical interface power domain is VREF_VTT. If PECI is not used, the corresponding MUX_CONTROL field for GPIO044 should be set to GPIO in order to minimize leakage current when VREF_VTT is not required.

2.16 Prochot Implementation

For the MEC1721/MEC1723, the Prochot signal is a VTR1 bidirectional signal, which VTR1 can be either 1.8V or 3.3V. This will require an external voltage translator circuit. This issue has no impact on the functionality of PECI.

The recommended implementation shown here is a circuit that uses an inexpensive 2n7002 FET. It drives GPIO160/PWM11/PROCHOT has an output only, but with polarity inverted to use a 2n7002 FET. It optionally accepts a PROCHOT input on the SB-TSI_CLK pin if an input is needed.

FIGURE 2-11: PROCHOT IMPLEMENTATION

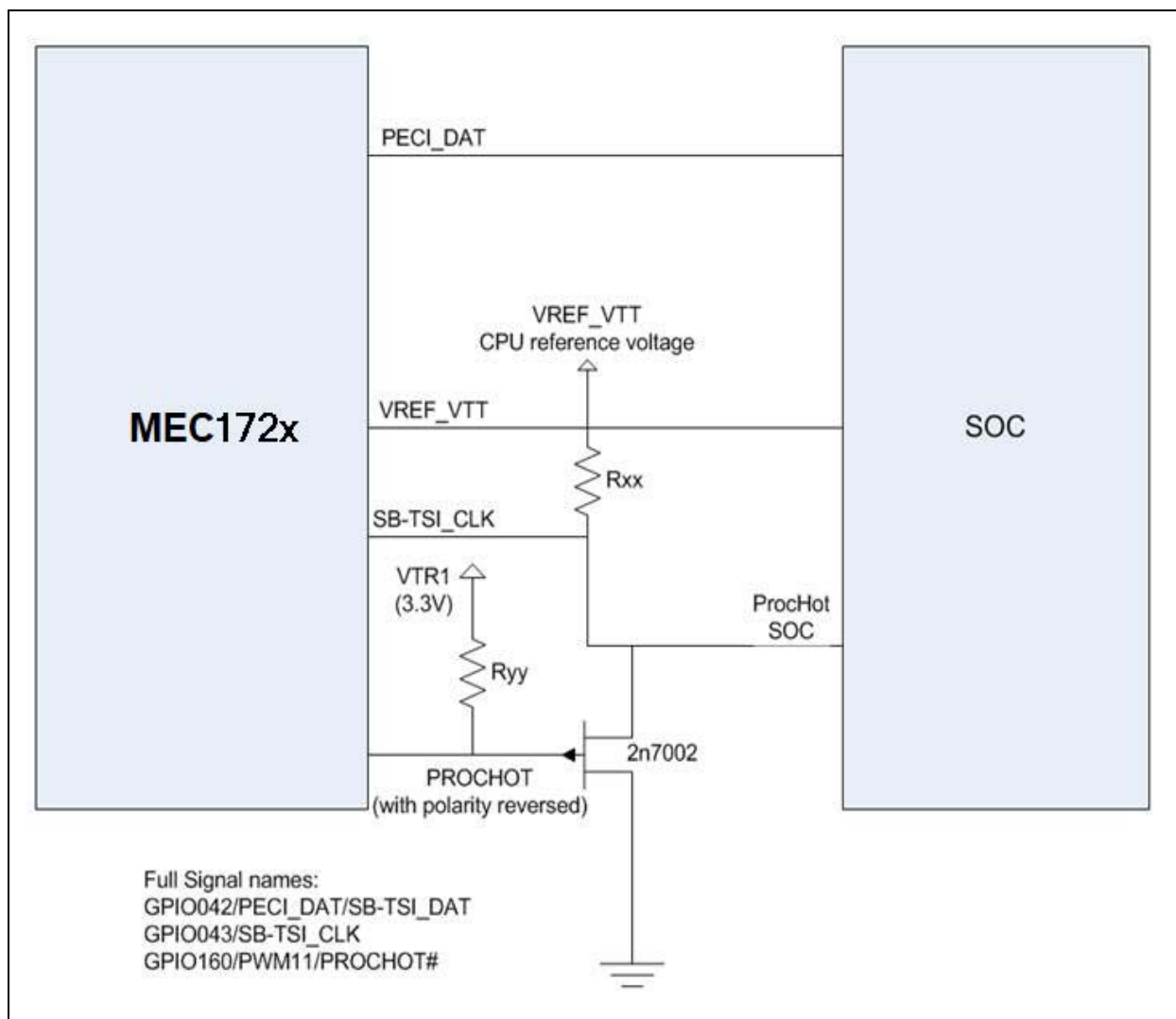

2.17 MEC1721/MEC1723 Shared SPI Flash Isolation Requirement

Per latest Intel PCH design, all the SPI lines to the PCH are tied to GND until the prime rails come up. In this case, designer has to implement one of the below:

- Isolation on all Shared SPI pins or
- Keep th PCH powered all the time or
- Wait for the Prime Rails to come up by holding the EC in reset by the RESET_IN# pin. The example circuitry is shown in the figure below.

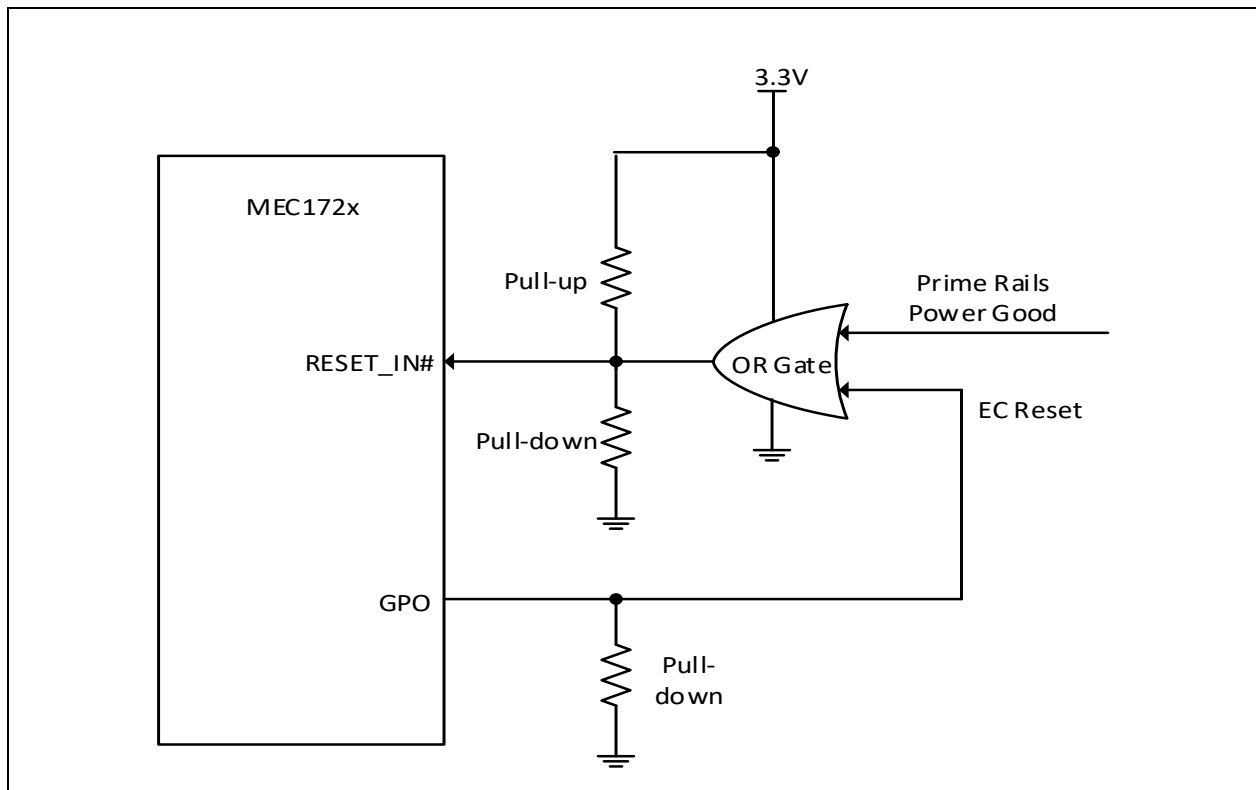

3.0 JTAG DESIGN AND LAYOUT GUIDE

This section provides general hardware information for using the MEC1721/MEC1723 JTAG interface and working with JTAG master and slaves.

This document includes the following topics:

- [Section 3.1, "MEC1721/MEC1723 JTAG Capabilities," on page 24](#)
- [Section 3.2, "General PCB Layout Considerations for JTAG," on page 24](#)
- [Section 3.3, "Pin Connections," on page 24](#)
- [Section 3.4, "JTAG Internal Pull-Up," on page 27](#)
- [Section 3.5, "JTAG Reset," on page 27](#)

3.1 MEC1721/MEC1723 JTAG Capabilities

MEC1721/MEC1723 devices have the following debug capabilities:

- JTAG-Based DAP Port, Comprised of SWJ-DP and AHB-AP Debugger Access Functions
- Full DWT Hardware Functionality: 4 Data Watchpoints and Execution Monitoring
- Full FPB Hardware Breakpoint Functionality: 6 Execution Breakpoints and 2 Literal (Data) Breakpoints
- Accessed via 4-wire JTAG or 2-wire ARM SWD
- Comprehensive ARM-Standard Trace Support: Full DWT, ITM, ETM, TPIU functionalities

3.2 General PCB Layout Considerations for JTAG

Please follow the PCI Specification's Routing and Layout Guidelines for the JTAG interface signals to support the JTAG interface speed up to 33MHz.

- In order to improve the clock transmission line's signal integrity, the following is recommended:
 - Keep the clock traces as straight as possible.
 - Use arc-shaped traces instead of right-angle bends.
 - Do not use multiple signal layers.
 - Do not use vias to reduce impedance change and reflection.
 - Place a ground plane next to the outer layer to minimize noise effect.
 - Terminate clock signals to minimize reflection.
- The JTAG cable that attaches to the MEC1721/MEC1723 motherboard has a standard 20-pin .1" spacing female connector on it. Normally, the MEC1721/MEC1723 motherboard just has a 20-pin 0.1" spacing pin strip on the board to mate with it.
- If the MEC1721/MEC1723 motherboard design does not have the space for a 20-pin male pin strip, then the board designer can place a 6 pin header on the motherboard and build a 6-pin to 20-pin adapter cable to attach to the 20-pin female connector on the JTAG cable. This is shown in Figure 3-1, "6-Pin to 20-Pin Adapter Board (w/ BOM)".

3.3 Pin Connections

3.3.1 4-WIRE JTAG CONNECTION

Six signals are the minimum number required on the motherboard side; these are described in [Table 3-1](#) and illustrated in [FIGURE 3-1: 6-Pin to 20-Pin Adapter Board \(w/ BOM\) on page 25](#).

TABLE 3-1: MEC1721/MEC1723 4-WIRE JTAG PINS

Name	JTAG Cable Connection
VTR	The motherboard VTR is always 3.3V. It is recommended to add a 49-ohm series resistor for motherboard protection. The JTAG cable senses the voltage level on this line and drives the JTAG logic levels to the same voltage level from the target system.
TDI	Test Data In
TMS	Test Mode Select
CLK	Test Clock

TABLE 3-1: MEC1721/MEC1723 4-WIRE JTAG PINS (CONTINUED)

Name	JTAG Cable Connection
TDO	Test Data Out
GND	Motherboard ground connect

FIGURE 3-1: 6-PIN TO 20-PIN ADAPTER BOARD (W/ BOM)

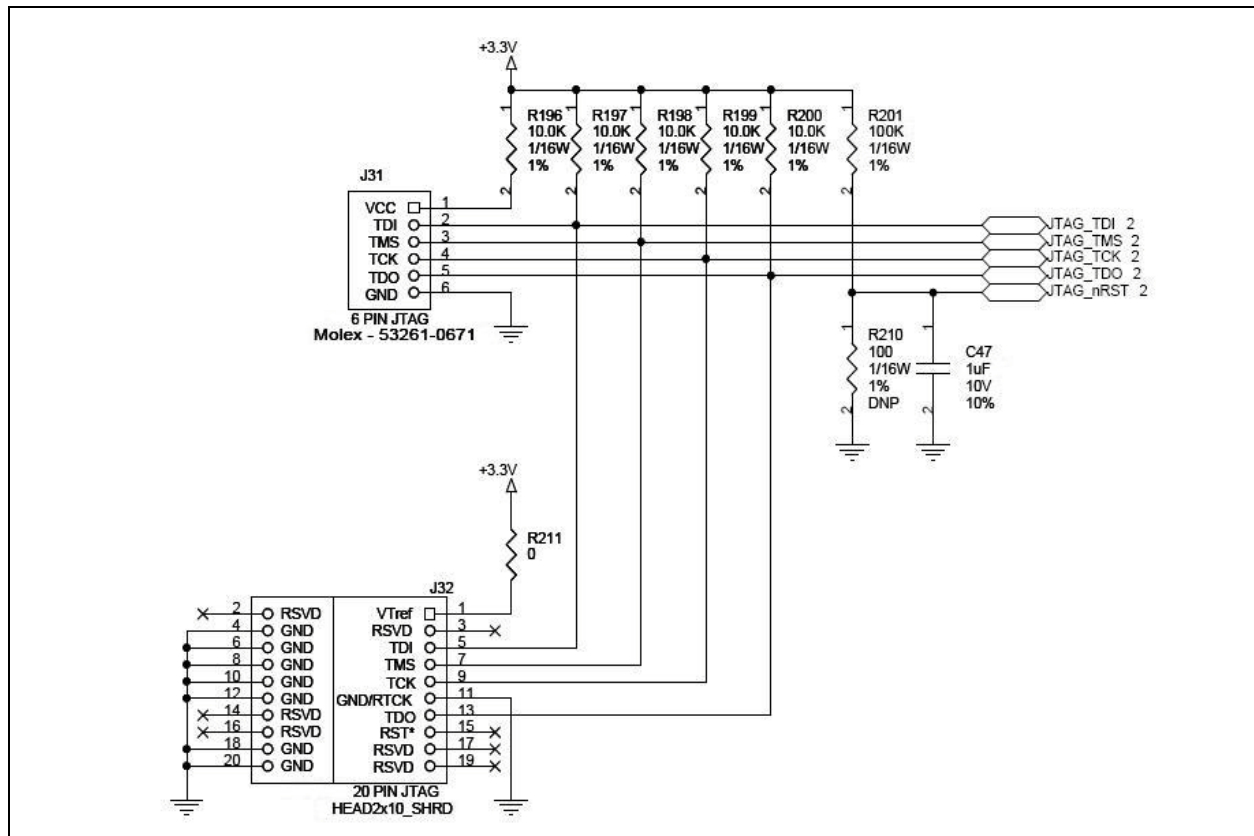

- Note 1:** The 10K pullups that are shown in Figure 3-1 are used on MEC1721/MEC1723 JTAG inputs to prevent them from floating when the JTAG cable is not attached.
- 2:** The MEC1721/MEC1723 JTAG RST# pin connects to a 100K pullup to always enable the JTAG interface. Board design can provide pads for a pullup and pulldown for this pin in motherboard layout.
- 3:** In order to prevent potential damage, use a keyed connector to avoid plugging the cable in backward which would result in a short between VTR and ground.
- 4:** Add zero-ohm resistors to the JTAG link if there is a JTAG chain is used.

3.3.2 2-WIRE JTAG CONNECTION

Five signals are the minimum number required on the motherboard side; these are described in Table 3-2.

TABLE 3-2: MEC1721/MEC1723 2-WIRE JTAG PINS

Name	JTAG Cable Connection
VTR	The motherboard VTR is always 3.3V.
SWDCLK	Use on JTAG_CLK pin if selected.
SWO	Use on JTAG_TDO pin if selected.
SWDIO	Use on JTAG_TMS pin if selected.
GND	Motherboard ground connect

Figure 3-2 shows the standard ARM Cortex 10 pins connector (a Samtec FTSH-105-01 w/ pin 7 removed).

FIGURE 3-2: 10-PIN CORTEX DEBUG (0.05") CONNECTOR

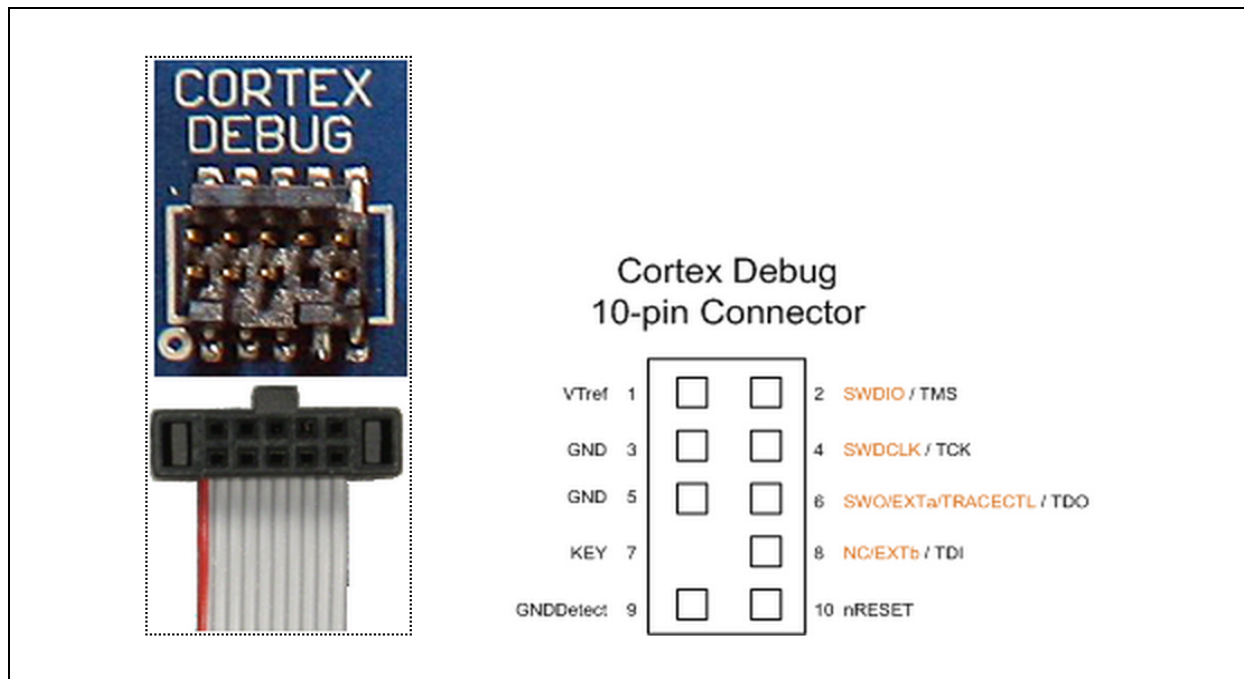

3.3.3 TRACE FUNCTIONS CONNECTION

To use the trace support functionalities, the additional signals are required on the motherboard side; these are described in [Table 3-3](#) and illustrated in [FIGURE 3-3: 20-Pin cortex debug with trace support \(0.05"\) Connector on page 27](#).

TABLE 3-3: MEC1721/MEC1723 JTAG PINS TO SUPPORT TRACE FUNCTIONS

Name	JTAG Cable Connection
TRACEDAT0	ARM Embedded Trace Macro Data 0
TRACEDAT1	ARM Embedded Trace Macro Data 1
TRACEDAT2	ARM Embedded Trace Macro Data 2
TRACEDAT3	ARM Embedded Trace Macro Data 3
TRACECLK	ARM Embedded Trace Macro Data Clock

The 20 pin connector is a Samtec FTSH-110-01 with pin 7 removed.

FIGURE 3-3: 20-PIN CORTEX DEBUG WITH TRACE SUPPORT (0.05") CONNECTOR

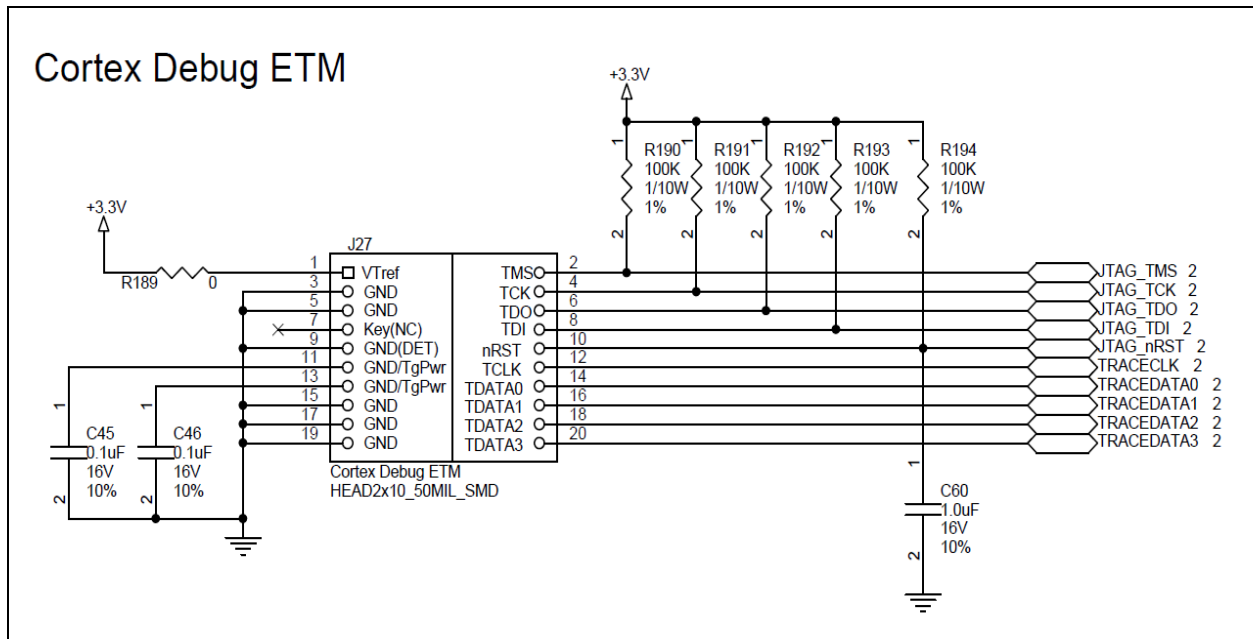

3.4 JTAG Internal Pull-Up

The firmware can select which debug pins to enable the internal pull-high. Default is disabled. Please see the MEC1721/MEC1723 Data Sheet DEBUG ENABLE REGISTER (4000_FC20h) at section 47.8.5 for more information.

3.5 JTAG Reset

When the JTAG_RST# pin is not asserted (logic'1'), the JTAG_TDI, JTAG_TDO, JTAG_TCK, JTAG_TMS signal functions in the JTAG interface are unconditionally routed to the JTAG interface; the Pin Control register for these pins has no effect. When the JTAG_RST# pin is asserted (logic'0'), the JTAG_TDI, JTAG_TDO, JTAG_TCK, JTAG_TMS signal functions in the JTAG interface are not routed to the interface and the Pin Control Register for these pins controls the muxing. The pin control registers cannot route the JTAG interface to the pins. The system board designer should terminate this pin in all functional states using jumpers, pullup or pulldown resistors, and so forth.

JTAG registers are set to their initial values by the assertion of the JTAG_RST# pin. The JTAG_RST# pin must be held low while the MEC1721/MEC1723 devices are powering up so the registers can be set to their proper default values. If JTAG_RST# is high during power up, the JTAG registers may be set to unpredictable values. This can trigger unwanted test modes and the system may not run correctly. As a result, the JTAG_RST# pin must be held low for at least 5.00 msec when applying VTR power.

Note: For more details on the JTAG_RST# pin, in particular JTAG_RST# functionality with respect to VTR power up events, as well as RESET1# reset input pin transitions, see the JTAG section in the MEC1721/MEC1723 Data Sheet.

The minimum required JTAG signals as shown in [Table 3-1](#) does not include the JTAG_RST# signal. There are several options to handle the absence of this pin as followed:

- Production Mode with JTAG Port Disable:
 - Hold the JTAG_RST# pin low with pulldown resistor to disable the JTAG port. Add a pullup resistor option (do not populate) for potential failure analysis to allow use of the JTAG interface. In this case, the JTAG_RST# pin must be manually held low at least 5.00 msec on power up.
- Production Mode with JTAG Port Enable:
 - Add a jumper to hold the JTAG_RST# line low during power up, then remove the jumper in order to ensure that it meets the 5.00 msec timing requirement.

AN3759

Optionally, put in hardware Resistor-Capacitor (RC) circuitry to force the JTAG_RST# signal low for at least 5.00 msec. For example:

1. Use a MEC1721/MEC1723 EVB with external power supply which shows the rise time less than 100 μ s.
2. RC = 100K ohms resistor pullup to VTR and 1 μ F capacitor.
3. The rising timing of VTR related to the JTAG_RST# signal is shown in [Figure 3-4](#); the falling time should be a reverse of the rising time.

Note: The RC values need to be changed in order to compensate for the power supply time to ensure a 5.00 msec reset pulse, measured from VTR = 3.3V to JTAG_RST# = 0.8V.

FIGURE 3-4: VTR VS. JTAG RISING TIME

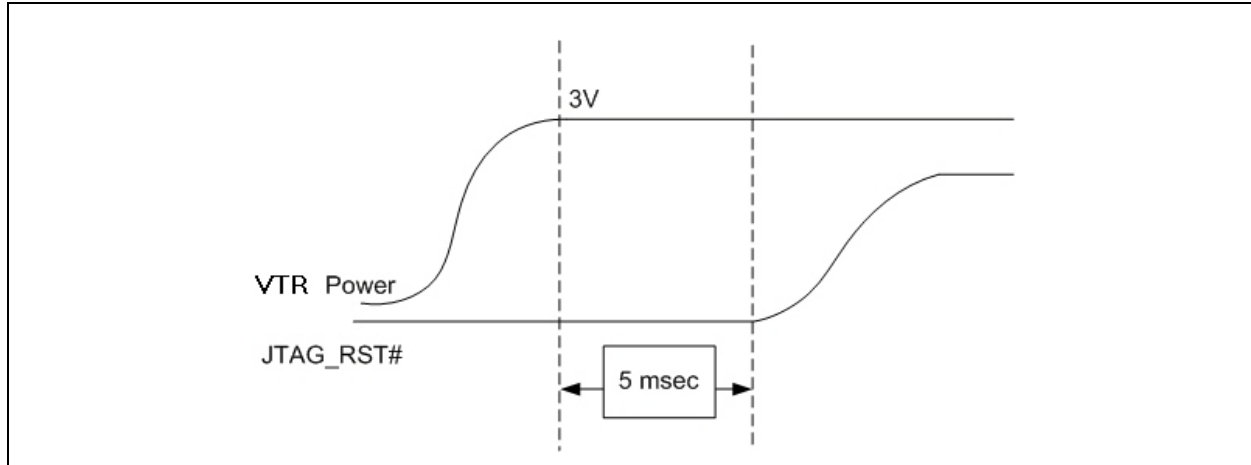

4.0 BOARDS BRING-UP DEBUG TIPS

Suggest checkpoints:

- VBAT, VTR1, VTR2, VTR3 are matching the power timing sequences per data sheet and at stable ON voltage levels.
- RESETI# pin has pull-high to VTR1 power rail.
- Check all strapping pins,
 - GPIO170 (JTAG_STRAP) MUST be pull-down by at least 10K ohm.
 - GPIO045 (CR_STRAP) should be pull-high for normal boot, non-crisis recovery.
 - GPIO207 (CMP_STRAP) should be pull-down as default even OTP is not enabled this feature by default.
 - GPIO055/SHD_CS0# (BSS_STRAP) should be pull-high for Shared SPI Flash boot mode or pull-down if eSPI MAF mode.
 - GPIO126 (UART_BSTRAP) should be pull-high for normal boot, even OTP is not enabled this feature by default.
- For Shared SPI flash implementation, if all above settings are correct, the Boot ROM will try to load SPI image from SHD_SPI flash, we can scope on the SHD_CLK pin to confirm if Boot ROM starts running.
 - If we don't see any SHD_CLK toggling, recheck the above power & strapping pins.
 - If we can see the full firmware image is loaded, but not executed, we will need to confirm the SPI image built is correct per the design, please refer to Boot ROM Addendum for details. Also, we can try different SPI settings such as slower speeds or dual/read mode to see if any differences.
- For eSPI MAF implementation,
 - Boot ROM should release the RSMRST# pin on GPIO055, make sure it does goes high.
 - EC will try to load firmware from PCH SPI Flash, we can scope on the PCH SPI CLK signal to see if this is working accordingly.
 - If any failure up to this point, we can try different SPI settings such as slower speeds or dual/read mode to see if any differences.
- For JTAG/SWD port & debugger connection,
 - Make sure the JTAG/SWD connection is available, and JTAG_RST# is pull-high per reference design.
 - Please note if any valid image is loaded and executed successfully, the JTAG/SWD is disabled by the Boot ROM.
 - If there is no valid image such as SPI flash is blanked, we should able to connect ARM-based debugger like ICD4/PICKIT4 or 3rd party debugger to the device.
 - If an valid image is loaded and executed, the application firmware is required to enable the JTAG/SWD port by the DEBUG ENABLE Register.

AN3759

APPENDIX A: APPLICATION NOTE REVISION HISTORY

TABLE A-1: REVISION HISTORY

Revision	Section/Figure/Entry	Correction
DS00003759B (09-20-21)	Section 2.7, "SPI Flash Implementation"	IOx Pull-High recommendation added.
	Section 4.0, "Boards bring-up debug tips"	Section added.
DS00003759A (12-01-20)	Document Release	

Note the following details of the code protection feature on Microchip products:

- Microchip products meet the specifications contained in their particular Microchip Data Sheet.
- Microchip believes that its family of products is secure when used in the intended manner, within operating specifications, and under normal conditions.
- Microchip values and aggressively protects its intellectual property rights. Attempts to breach the code protection features of Microchip product is strictly prohibited and may violate the Digital Millennium Copyright Act.
- Neither Microchip nor any other semiconductor manufacturer can guarantee the security of its code. Code protection does not mean that we are guaranteeing the product is “unbreakable”. Code protection is constantly evolving. Microchip is committed to continuously improving the code protection features of our products.

This publication and the information herein may be used only with Microchip products, including to design, test, and integrate Microchip products with your application. Use of this information in any other manner violates these terms. Information regarding device applications is provided only for your convenience and may be superseded by updates. It is your responsibility to ensure that your application meets with your specifications. Contact your local Microchip sales office for additional support or, obtain additional support at <https://www.microchip.com/en-us/support/design-help/client-support-services>.

THIS INFORMATION IS PROVIDED BY MICROCHIP "AS IS". MICROCHIP MAKES NO REPRESENTATIONS OR WARRANTIES OF ANY KIND WHETHER EXPRESS OR IMPLIED, WRITTEN OR ORAL, STATUTORY OR OTHERWISE, RELATED TO THE INFORMATION INCLUDING BUT NOT LIMITED TO ANY IMPLIED WARRANTIES OF NON-INFRINGEMENT, MERCHANTABILITY, AND FITNESS FOR A PARTICULAR PURPOSE, OR WARRANTIES RELATED TO ITS CONDITION, QUALITY, OR PERFORMANCE.

IN NO EVENT WILL MICROCHIP BE LIABLE FOR ANY INDIRECT, SPECIAL, PUNITIVE, INCIDENTAL, OR CONSEQUENTIAL LOSS, DAMAGE, COST, OR EXPENSE OF ANY KIND WHATSOEVER RELATED TO THE INFORMATION OR ITS USE, HOWEVER CAUSED, EVEN IF MICROCHIP HAS BEEN ADVISED OF THE POSSIBILITY OR THE DAMAGES ARE FORESEEABLE. TO THE FULLEST EXTENT ALLOWED BY LAW, MICROCHIP'S TOTAL LIABILITY ON ALL CLAIMS IN ANY WAY RELATED TO THE INFORMATION OR ITS USE WILL NOT EXCEED THE AMOUNT OF FEES, IF ANY, THAT YOU HAVE PAID DIRECTLY TO MICROCHIP FOR THE INFORMATION.

Use of Microchip devices in life support and/or safety applications is entirely at the buyer's risk, and the buyer agrees to defend, indemnify and hold harmless Microchip from any and all damages, claims, suits, or expenses resulting from such use. No licenses are conveyed, implicitly or otherwise, under any Microchip intellectual property rights unless otherwise stated.

Trademarks

The Microchip name and logo, the Microchip logo, Adaptec, AnyRate, AVR, AVR logo, AVR Freaks, BesTime, BitCloud, CryptoMemory, CryptoRF, dsPIC, flexPWR, HELDO, IGLOO, JukeBlox, KeeLoq, Klear, LANCheck, LinkMD, maXStylus, maXTouch, MediaLB, megaAVR, Microsemi, Microsemi logo, MOST, MOST logo, MPLAB, OptoLyzer, PIC, picoPower, PICSTART, PIC32 logo, PolarFire, Prochip Designer, QTouch, SAM-BA, SenGenuity, SpyNIC, SST, SST Logo, SuperFlash, Symmetricom, SyncServer, Tachyon, TimeSource, tinyAVR, UNI/O, Vectron, and XMEGA are registered trademarks of Microchip Technology Incorporated in the U.S.A. and other countries.

AgileSwitch, APT, ClockWorks, The Embedded Control Solutions Company, EtherSynch, Flashtec, Hyper Speed Control, HyperLight Load, IntelliMOS, Libero, motorBench, mTouch, Powermite 3, Precision Edge, ProASIC, ProASIC Plus, ProASIC Plus logo, Quiet-Wire, SmartFusion, SyncWorld, Temux, TimeCesium, TimeHub, TimePictra, TimeProvider, TrueTime, WinPath, and ZL are registered trademarks of Microchip Technology Incorporated in the U.S.A.

Adjacent Key Suppression, AKS, Analog-for-the-Digital Age, Any Capacitor, AnyIn, AnyOut, Augmented Switching, BlueSky, BodyCom, CodeGuard, CryptoAuthentication, CryptoAutomotive, CryptoCompanion, CryptoController, dsPICDEM, dsPICDEM.net, Dynamic Average Matching, DAM, ECAN, Espresso T1S, EtherGREEN, GridTime, IdealBridge, In-Circuit Serial Programming, ICSP, INICnet, Intelligent Paralleling, Inter-Chip Connectivity, JitterBlocker, Knob-on-Display, maxCrypto, maxView, memBrain, Mindi, MiWi, MPASM, MPF, MPLAB Certified logo, MPLIB, MPLINK, MultiTRAK, NetDetach, NVM Express, NVMe, Omniscient Code Generation, PICDEM, PICDEM.net, PICkit, PICtail, PowerSmart, PureSilicon, QMatrix, REAL ICE, Ripple Blocker, RTAX, RTG4, SAM-ICE, Serial Quad I/O, simpleMAP, SimpliPHY, SmartBuffer, SmartHLS, SMART-I.S., storClad, SQL, SuperSwitcher, SuperSwitcher II, Switchtec, SynchroPHY, Total Endurance, TSHARC, USBCheck, VariSense, VectorBlox, VeriPHY, ViewSpan, WiperLock, XpressConnect, and ZENA are trademarks of Microchip Technology Incorporated in the U.S.A. and other countries.

SQTP is a service mark of Microchip Technology Incorporated in the U.S.A.

The Adaptec logo, Frequency on Demand, Silicon Storage Technology, Symmcom, and Trusted Time are registered trademarks of Microchip Technology Inc. in other countries.

GestIC is a registered trademark of Microchip Technology Germany II GmbH & Co. KG, a subsidiary of Microchip Technology Inc., in other countries.

AMBA, Arm, Arm7, Arm7TDMI, Arm9, Arm11, Artisan, big.LITTLE, Cordio, CoreLink, CoreSight, Cortex, DesignStart, DynamIQ, Jazelle, Keil, Mali, Mbed, Mbed Enabled, NEON, POP, RealView, SecurCore, Socrates, Thumb, TrustZone, ULINK, ULINK2, ULINK-ME, ULINK-PLUS, ULINKpro, µVision, Versatile are trademarks or registered trademarks of Arm Limited (or its subsidiaries) in the US and/or elsewhere.

All other trademarks mentioned herein are property of their respective companies.

© 2021, Microchip Technology Incorporated and its subsidiaries.

All Rights Reserved.

ISBN: 9781522489467

For information regarding Microchip's Quality Management Systems, please visit www.microchip.com/quality.



Worldwide Sales and Service

AMERICAS

Corporate Office
2355 West Chandler Blvd.
Chandler, AZ 85224-6199
Tel: 480-792-7200
Fax: 480-792-7277
Technical Support:
<http://www.microchip.com/support>
Web Address:
www.microchip.com

Atlanta
Duluth, GA
Tel: 678-957-9614
Fax: 678-957-1455

Austin, TX
Tel: 512-257-3370

Boston
Westborough, MA
Tel: 774-760-0087
Fax: 774-760-0088

Chicago
Itasca, IL
Tel: 630-285-0071
Fax: 630-285-0075

Dallas
Addison, TX
Tel: 972-818-7423
Fax: 972-818-2924

Detroit
Novi, MI
Tel: 248-848-4000

Houston, TX
Tel: 281-894-5983

Indianapolis
Noblesville, IN
Tel: 317-773-8323
Fax: 317-773-5453
Tel: 317-536-2380

Los Angeles
Mission Viejo, CA
Tel: 949-462-9523
Fax: 949-462-9608
Tel: 951-273-7800

Raleigh, NC
Tel: 919-844-7510

New York, NY
Tel: 631-435-6000

San Jose, CA
Tel: 408-735-9110
Tel: 408-436-4270

Canada - Toronto
Tel: 905-695-1980
Fax: 905-695-2078

ASIA/PACIFIC

Australia - Sydney
Tel: 61-2-9868-6733

China - Beijing
Tel: 86-10-8569-7000

China - Chengdu
Tel: 86-28-8665-5511

China - Chongqing
Tel: 86-23-8980-9588

China - Dongguan
Tel: 86-769-8702-9880

China - Guangzhou
Tel: 86-20-8755-8029

China - Hangzhou
Tel: 86-571-8792-8115

China - Hong Kong SAR
Tel: 852-2943-5100

China - Nanjing
Tel: 86-25-8473-2460

China - Qingdao
Tel: 86-532-8502-7355

China - Shanghai
Tel: 86-21-3326-8000

China - Shenyang
Tel: 86-24-2334-2829

China - Shenzhen
Tel: 86-755-8864-2200

China - Suzhou
Tel: 86-186-6233-1526

China - Wuhan
Tel: 86-27-5980-5300

China - Xian
Tel: 86-29-8833-7252

China - Xiamen
Tel: 86-592-2388138

China - Zhuhai
Tel: 86-756-3210040

ASIA/PACIFIC

India - Bangalore
Tel: 91-80-3090-4444

India - New Delhi
Tel: 91-11-4160-8631

India - Pune
Tel: 91-20-4121-0141

Japan - Osaka
Tel: 81-6-6152-7160

Japan - Tokyo
Tel: 81-3-6880-3770

Korea - Daegu
Tel: 82-53-744-4301

Korea - Seoul
Tel: 82-2-554-7200

Malaysia - Kuala Lumpur
Tel: 60-3-7651-7906

Malaysia - Penang
Tel: 60-4-227-8870

Philippines - Manila
Tel: 63-2-634-9065

Singapore
Tel: 65-6334-8870

Taiwan - Hsin Chu
Tel: 886-3-577-8366

Taiwan - Kaohsiung
Tel: 886-7-213-7830

Taiwan - Taipei
Tel: 886-2-2508-8600

Thailand - Bangkok
Tel: 66-2-694-1351

Vietnam - Ho Chi Minh
Tel: 84-28-5448-2100

EUROPE

Austria - Wels
Tel: 43-7242-2244-39
Fax: 43-7242-2244-393

Denmark - Copenhagen
Tel: 45-4485-5910
Fax: 45-4485-2829

Finland - Espoo
Tel: 358-9-4520-820

France - Paris
Tel: 33-1-69-53-63-20
Fax: 33-1-69-30-90-79

Germany - Garching
Tel: 49-8931-9700

Germany - Haan
Tel: 49-2129-3766400

Germany - Heilbronn
Tel: 49-7131-72400

Germany - Karlsruhe
Tel: 49-721-625370

Germany - Munich
Tel: 49-89-627-144-0
Fax: 49-89-627-144-44

Germany - Rosenheim
Tel: 49-8031-354-560

Israel - Ra'anana
Tel: 972-9-744-7705

Italy - Milan
Tel: 39-0331-742611
Fax: 39-0331-466781

Italy - Padova
Tel: 39-049-7625286

Netherlands - Drunen
Tel: 31-416-690399
Fax: 31-416-690340

Norway - Trondheim
Tel: 47-7288-4388

Poland - Warsaw
Tel: 48-22-3325737

Romania - Bucharest
Tel: 40-21-407-87-50

Spain - Madrid
Tel: 34-91-708-08-90
Fax: 34-91-708-08-91

Sweden - Gothenberg
Tel: 46-31-704-60-40

Sweden - Stockholm
Tel: 46-8-5090-4654

UK - Wokingham
Tel: 44-118-921-5800
Fax: 44-118-921-5820