



**MICROCHIP**

---

**MIC2127A**  
**Evaluation Board**  
**User's Guide**

---

---

**Note the following details of the code protection feature on Microchip devices:**

- Microchip products meet the specification contained in their particular Microchip Data Sheet.
- Microchip believes that its family of products is one of the most secure families of its kind on the market today, when used in the intended manner and under normal conditions.
- There are dishonest and possibly illegal methods used to breach the code protection feature. All of these methods, to our knowledge, require using the Microchip products in a manner outside the operating specifications contained in Microchip's Data Sheets. Most likely, the person doing so is engaged in theft of intellectual property.
- Microchip is willing to work with the customer who is concerned about the integrity of their code.
- Neither Microchip nor any other semiconductor manufacturer can guarantee the security of their code. Code protection does not mean that we are guaranteeing the product as "unbreakable."

Code protection is constantly evolving. We at Microchip are committed to continuously improving the code protection features of our products. Attempts to break Microchip's code protection feature may be a violation of the Digital Millennium Copyright Act. If such acts allow unauthorized access to your software or other copyrighted work, you may have a right to sue for relief under that Act.

---

Information contained in this publication regarding device applications and the like is provided only for your convenience and may be superseded by updates. It is your responsibility to ensure that your application meets with your specifications. MICROCHIP MAKES NO REPRESENTATIONS OR WARRANTIES OF ANY KIND WHETHER EXPRESS OR IMPLIED, WRITTEN OR ORAL, STATUTORY OR OTHERWISE, RELATED TO THE INFORMATION, INCLUDING BUT NOT LIMITED TO ITS CONDITION, QUALITY, PERFORMANCE, MERCHANTABILITY OR FITNESS FOR PURPOSE. Microchip disclaims all liability arising from this information and its use. Use of Microchip devices in life support and/or safety applications is entirely at the buyer's risk, and the buyer agrees to defend, indemnify and hold harmless Microchip from any and all damages, claims, suits, or expenses resulting from such use. No licenses are conveyed, implicitly or otherwise, under any Microchip intellectual property rights unless otherwise stated.

### Trademarks

The Microchip name and logo, the Microchip logo, Adaptec, AnyRate, AVR, AVR logo, AVR Freaks, BesTime, BitCloud, chipKIT, chipKIT logo, CryptoMemory, CryptoRF, dsPIC, FlashFlex, flexPWR, HELDO, IGLOO, JukeBlox, KeeLoq, Klear, LANCheck, LinkMD, maXStylus, maXTouch, MediaLB, megaAVR, Microsemi, Microsemi logo, MOST, MOST logo, MPLAB, OptoLyzer, PackeTime, PIC, picoPower, PICSTART, PIC32 logo, PolarFire, Prochip Designer, QTouch, SAM-BA, SenGenuity, SpyNIC, SST, SST Logo, SuperFlash, Symmetricom, SyncServer, Tachyon, TempTracker, TimeSource, tinyAVR, UNI/O, Vectron, and XMEGA are registered trademarks of Microchip Technology Incorporated in the U.S.A. and other countries.

APT, ClockWorks, The Embedded Control Solutions Company, EtherSynch, FlashTec, Hyper Speed Control, HyperLight Load, IntelliMOS, Libero, motorBench, mTouch, Powermite 3, Precision Edge, ProASIC, ProASIC Plus, ProASIC Plus logo, Quiet-Wire, SmartFusion, SyncWorld, Temux, TimeCesium, TimeHub, TimePictra, TimeProvider, Vite, WinPath, and ZL are registered trademarks of Microchip Technology Incorporated in the U.S.A.

Adjacent Key Suppression, AKS, Analog-for-the-Digital Age, Any Capacitor, AnyIn, AnyOut, BlueSky, BodyCom, CodeGuard, CryptoAuthentication, CryptoAutomotive, CryptoCompanion, CryptoController, dsPICDEM, dsPICDEM.net, Dynamic Average Matching, DAM, ECAN, EtherGREEN, In-Circuit Serial Programming, ICSP, INICnet, Inter-Chip Connectivity, JitterBlocker, KlearNet, KlearNet logo, memBrain, Mindi, MiWi, MPASM, MPF, MPLAB Certified logo, MPLIB, MPLINK, MultiTRAK, NetDetach, Omniscient Code Generation, PICDEM, PICDEM.net, PICKit, PICtail, PowerSmart, PureSilicon, QMatrix, REAL ICE, Ripple Blocker, SAM-ICE, Serial Quad I/O, SMART-I.S., SQL, SuperSwitcher, SuperSwitcher II, Total Endurance, TSHARC, USBCheck, VariSense, ViewSpan, WiperLock, Wireless DNA, and ZENA are trademarks of Microchip Technology Incorporated in the U.S.A. and other countries.

SQTP is a service mark of Microchip Technology Incorporated in the U.S.A.

The Adaptec logo, Frequency on Demand, Silicon Storage Technology, and Symmcom are registered trademarks of Microchip Technology Inc. in other countries.

GestIC is a registered trademark of Microchip Technology Germany II GmbH & Co. KG, a subsidiary of Microchip Technology Inc., in other countries.

All other trademarks mentioned herein are property of their respective companies.

© 2016 - 2019, Microchip Technology Incorporated, All Rights Reserved.

ISBN: 978-1-5224-4777-1

For information regarding Microchip's Quality Management Systems, please visit [www.microchip.com/quality](http://www.microchip.com/quality).

**Table of Contents**

<b>Preface</b> .....	<b>5</b>
Introduction.....	5
Document Layout .....	5
Conventions Used in this Guide .....	6
Recommended Reading.....	7
The Microchip Website .....	7
Customer Support .....	7
Document Revision History .....	7
 <b>Chapter 1. Product Overview</b>	
1.1 Introduction .....	9
1.2 MIC2127A Evaluation Board Overview .....	10
1.3 MIC2127A Evaluation Board Features .....	10
1.4 What the MIC2127A Evaluation Board Kit includes .....	10
 <b>Chapter 2. Installation and Operation</b>	
2.1 System and configuration requirements .....	11
2.2 Board Setup .....	11
2.3 Circuit Description .....	12
2.3.1 Enabling and Disabling the MIC2127A Evaluation Board .....	12
2.3.2 Selecting the Light Load Operating Mode (MODE) .....	12
2.3.3 Auxiliary Bootstrap LDO (EXTVDD) .....	12
2.3.4 Setting the Output Voltage .....	12
2.3.5 SW Node .....	13
2.3.6 Current Limit .....	13
2.3.7 Setting the Switching Frequency .....	15
2.3.8 Loop Gain Measurement .....	15
 <b>Appendix A. Schematic and Layouts</b>	
A.1 Introduction .....	17
A.2 Board – Schematic .....	18
A.3 Board – Top Silk Layer .....	19
A.4 Board – Top Copper Layer .....	20
A.5 Board – Mid Copper Layer 1 .....	21
A.6 Board – Mid Copper Layer 2 .....	22
A.7 Board – Bottom Copper Layer .....	23
A.8 Board – Bottom Silk Layer .....	24
 <b>Appendix B. Bill of Materials (BOM)</b>	
<b>Worldwide Sales and Service</b> .....	<b>27</b>

# MIC2127A Evaluation Board User's Guide

---

---

---

## Preface

---

---

### NOTICE TO CUSTOMERS

All documentation becomes dated, and this manual is no exception. Microchip tools and documentation are constantly evolving to meet customer needs, so some actual dialogs and/or tool descriptions may differ from those in this document. Please refer to our website ([www.microchip.com](http://www.microchip.com)) to obtain the latest documentation available.

Documents are identified with a “DS” number. This number is located on the bottom of each page, in front of the page number. The numbering convention for the DS number is “DSXXXXXXXXA”, where “XXXXXXXX” is the document number and “A” is the revision level of the document.

For the most up-to-date information on development tools, see the MPLAB® IDE online help. Select the Help menu, and then Topics, to open a list of available online help files.

## INTRODUCTION

This chapter contains general information that will be useful to know before using the MIC2127A Evaluation Board. Items discussed in this chapter include:

- [Document Layout](#)
- [Conventions Used in this Guide](#)
- [Recommended Reading](#)
- [The Microchip Website](#)
- [Customer Support](#)
- [Document Revision History](#)

## DOCUMENT LAYOUT

This document describes how to use the MIC2127A Evaluation Board. The document is organized as follows:

- **Chapter 1. “Product Overview”** – Important information about the MIC2127A Evaluation Board.
- **Chapter 2. “Installation and Operation”** – Includes instructions on installing and starting the MIC2127A Evaluation Board.
- **Appendix A. “Schematic and Layouts”** – Shows the schematic and layout diagrams for the MIC2127A Evaluation Board.
- **Appendix B. “Bill of Materials (BOM)”** – Lists the parts used to build the MIC2127A Evaluation Board.

# MIC2128 Evaluation Board User's Guide

## CONVENTIONS USED IN THIS GUIDE

This manual uses the following documentation conventions:

### DOCUMENTATION CONVENTIONS

Description	Represents	Examples
<b>Arial font:</b>		
Italic characters	Referenced books	<i>MPLAB® IDE User's Guide</i>
	Emphasized text	...is the <i>only</i> compiler...
Initial caps	A window	the Output window
	A dialog	the Settings dialog
	A menu selection	select Enable Programmer
Quotes	A field name in a window or dialog	"Save project before build"
Underlined, italic text with right angle bracket	A menu path	<u><i>File</i></u> >Save
Bold characters	A dialog button	Click <b>OK</b>
	A tab	Click the <b>Power</b> tab
N'Rnnnn	A number in verilog format, where N is the total number of digits, R is the radix and n is a digit.	4'b0010, 2'hF1
Text in angle brackets < >	A key on the keyboard	Press <Enter>, <F1>
<b>Courier New font:</b>		
Plain Courier New	Sample source code	#define START
	Filenames	autoexec.bat
	File paths	c:\mcc18\h
	Keywords	_asm, _endasm, static
	Command-line options	-Opa+, -Opa-
	Bit values	0, 1
	Constants	0xFF, 'A'
Italic Courier New	A variable argument	<i>file.o</i> , where <i>file</i> can be any valid filename
Square brackets [ ]	Optional arguments	mcc18 [options] <i>file</i> [options]
Curly brackets and pipe character: {   }	Choice of mutually exclusive arguments; an OR selection	errorlevel {0 1}
Ellipses...	Replaces repeated text	var_name [, var_name...]
	Represents code supplied by user	void main (void) { ... }

## RECOMMENDED READING

This user's guide describes how to use the MIC2127A Evaluation Board. Another useful document is listed below. The following Microchip document is available and recommended as a supplemental reference resource:

- **MIC2127A Data Sheet – “75V, Synchronous Buck Controller Featuring Adaptive On-Time Control” (DS20005676A)**

## THE MICROCHIP WEBSITE

Microchip provides online support via our website at [www.microchip.com](http://www.microchip.com). This website is used as a means to make files and information easily available to customers. Accessible by using your favorite Internet browser, the website contains the following information:

- **Product Support** – Data sheets and errata, application notes and sample programs, design resources, user's guides and hardware support documents, latest software releases and archived software
- **General Technical Support** – Frequently Asked Questions (FAQs), technical support requests, online discussion groups, Microchip consultant program member listing
- **Business of Microchip** – Product selector and ordering guides, latest Microchip press releases, listing of seminars and events, listings of Microchip sales offices, distributors and factory representatives

## CUSTOMER SUPPORT

Users of Microchip products can receive assistance through several channels:

- Distributor or Representative
- Local Sales Office
- Field Application Engineer (FAE)
- Technical Support

Customers should contact their distributor, representative or field application engineer (FAE) for support. Local sales offices are also available to help customers. A listing of sales offices and locations is included in the back of this document.

Technical support is available through the website at:  
<http://www.microchip.com/support>.

## DOCUMENT REVISION HISTORY

### Revision A (December 2016)

- Initial release of this document.

### Revision B (July 2019)

- Updated image **Section A.2 “Board – Schematic”**.

# MIC2128 Evaluation Board User's Guide

---

NOTES:

**Chapter 1. Product Overview**

**1.1 INTRODUCTION**

This document describes the MIC2127A Evaluation Board and covers the following topics:

- MIC2127A Evaluation Board Overview
- MIC2127A Evaluation Board Features
- What the MIC2127A Evaluation Board Kit Contains

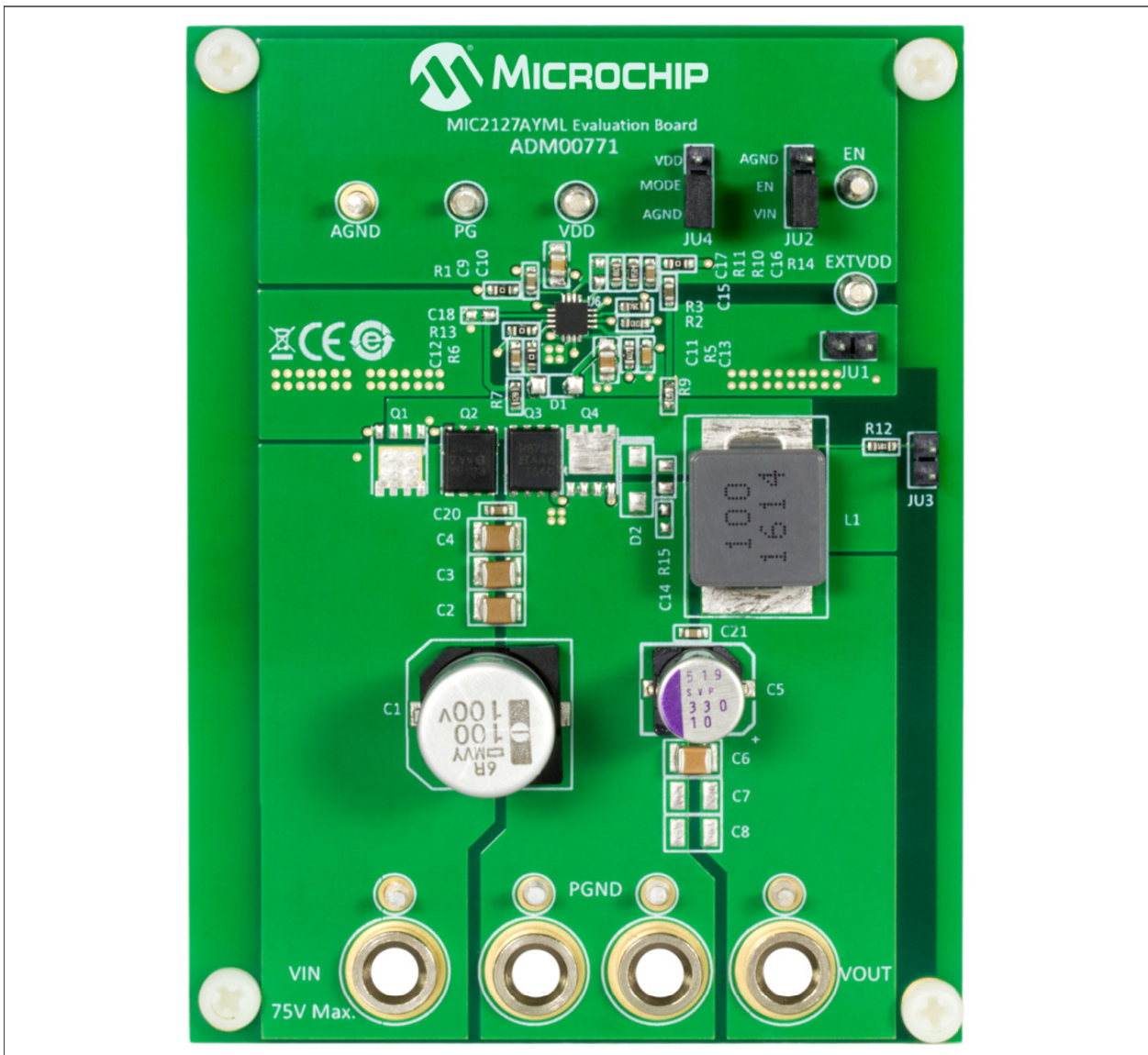

**FIGURE 1-1:** MIC2127A Evaluation Board Overview.

# MIC2127A Evaluation Board User's Guide

---

## 1.2 MIC2127A EVALUATION BOARD OVERVIEW

The MIC2127A is a constant-frequency, synchronous buck controller featuring a unique adaptive on-time control architecture and HyperLight Load® mode. The MIC2127A operates over an input supply range of 4.5V to 75V. The output voltage is adjustable from 0.6V to 30V with an ensured accuracy of  $\pm 1\%$ . The device features programmable switching frequency from 270 kHz to 800 kHz.

## 1.3 MIC2127A EVALUATION BOARD FEATURES

The MIC2127A Evaluation Board features:

- Wide input voltage range from 9V to 75V
- 5V preset output voltage
- Up to 5A load current support
- 300 KHz switching frequency
- Light load mode selection jumper (JU4)
- An option to supply the MIC2127A internal circuits bias power and gate drive from output voltage (JU1)
- Enable jumper to enable/disable the MIC2127A
- Power Good (PG) test point

## 1.4 WHAT THE MIC2127A EVALUATION BOARD KIT INCLUDES

The MIC2127A Evaluation Board kit includes the following items:

- MIC2127A Evaluation Board (ADM00771)
- Important Information Sheet

---

---

## Chapter 2. Installation and Operation

---

---

### 2.1 SYSTEM AND CONFIGURATION REQUIREMENTS

The MIC2127A Evaluation Board requires the following:

- DC Power supply which is rated for 9V to 75V with at least 5A current capability.
- Load that can sink up to 5A. The load can either be a resistive or an active load.
- A multimeter or a voltmeter for output voltage measurement

**Note:** The MIC2127A Evaluation Board does not have reverse polarity protection. Applying a negative voltage to the VIN and PGND terminals may damage the device. The maximum input voltage for the board is 75V. Exceeding 75V could damage the device.

### 2.2 BOARD SETUP

Follow these steps prior to using the MIC2127A Evaluation Board:

1. Set the DC power supply output voltage within the range of 9V to 75V. Do not connect the DC power supply until Step 4.
2. Set the supply current limit to 0.1A.
3. Disable the DC power supply
4. Connect the positive terminal of the power supply to the VIN connector and the negative terminal to the PGND terminal on the evaluation board. Do not apply power until Step 9.
5. Connect a voltmeter across the VOUT and PGND terminals.
6. Ensure that a shunt is placed between the EN and VIN on jumper JU2.
7. Ensure that a shunt is placed either between MODE and VDD or MODE and AGND, on the jumper JU4.
8. Turn on the power supply and verify that the output voltage is regulated to  $5V \pm 5\%$ .
9. Disable the supply.
10. Increase the supply current limit to at least 5A and connect load across the VOUT and PGND terminals. In case of resistive load, ensure that the resistor power rating is high enough to dissipate the output power
11. Turn on the supply and verify the output voltage is regulated to  $5V \pm 5\%$ .

# MIC2127A Evaluation Board User's Guide

## 2.3 CIRCUIT DESCRIPTION

This section describes the working principles and limitations that should be taken into account when using the MIC2127A Evaluation Board.

### 2.3.1 Enabling and Disabling the MIC2127A Evaluation Board

The MIC2127A features a logic level enable pin (EN) which can be used to enable/disable switching. Table 2-1 shows the jumper JU2, setting for enabling/disabling the MIC2127A switching:

**TABLE 2-1: ENABLE/DISABLE JUMPER (JU2) SETTING**

Shunt Position	Enable/Disable
Between EN and VIN	Enabled
Between EN and AGND	Disabled

### 2.3.2 Selecting the Light Load Operating Mode (MODE)

The MIC2127A features a MODE pin which allows the user to select either continuous conduction mode or HyperLight Load (HLL) mode at light loads. Continuous conduction mode results in almost constant switching frequency over the entire load current range. HLL mode results in higher efficiency at light loads by varying the switching frequency with load current.

Table 2-2 shows the jumper JU4, setting for selecting light load mode.

**TABLE 2-2: LIGHT LOAD MODE JUMPER (JU4) SETTING**

Shunt Position	Enable/Disable
Between MODE and VDD	Continuous Conduction Mode
Between MODE and AGND	Hyper Light Load Mode

### 2.3.3 Auxiliary Bootstrap LDO (EXTVDD)

The MIC2127A features an auxiliary bootstrap LDO which improves the system efficiency by supplying the MIC2127A internal circuit bias power and gate drivers from the converter output voltage. This LDO is enabled when the voltage on the EXTVDD pin is above 4.6V (typical) and at the same time, the main LDO which operates from VIN, is disabled to reduce power consumption.

Place a shunt on the JU1 jumper to supply the MIC2127A internal circuits bias power and gate drivers from the output of the converter.

### 2.3.4 Setting the Output Voltage

The output voltage on the MIC2127A Evaluation Board is determined by the feedback divider as given in Equation 2-1:

**EQUATION 2-1: EQUATION 1**

$$V_{OUT} = V_{FB} \times \left( 1 + \frac{R10}{R11} \right)$$

# Installation and Operation

The MIC2127A output is preset to 5V. All other voltages can be set by modifying R11 value according to Equation 2-2:

## EQUATION 2-2: EQUATION 2

$$R11 = \frac{R10}{\frac{V_{OUT}}{V_{FB}} - 1}$$

where:

$$V_{FB} = 0.6V$$

For output voltage higher than 5V, output capacitors and EXTVDV pin bypass capacitor (C13) of voltage rating higher than the set output voltage should be used.

### 2.3.5 SW Node

Test point JU3 (VSW) is placed for monitoring the switching waveform, one of the most critical waveforms for the converter.

### 2.3.6 Current Limit

The MIC2127A Evaluation Board uses the low-side MOSFET  $R_{DS(ON)}$  to sense inductor current. In each switching cycle of the MIC2127A converter, the inductor current is sensed by monitoring the voltage across the low-side MOSFET during the OFF period of the switching cycle during which low-side MOSFET is ON. An internal current source of 100  $\mu A$  generates a voltage across the external current limit setting resistor R7 as show in Figure 2-1.

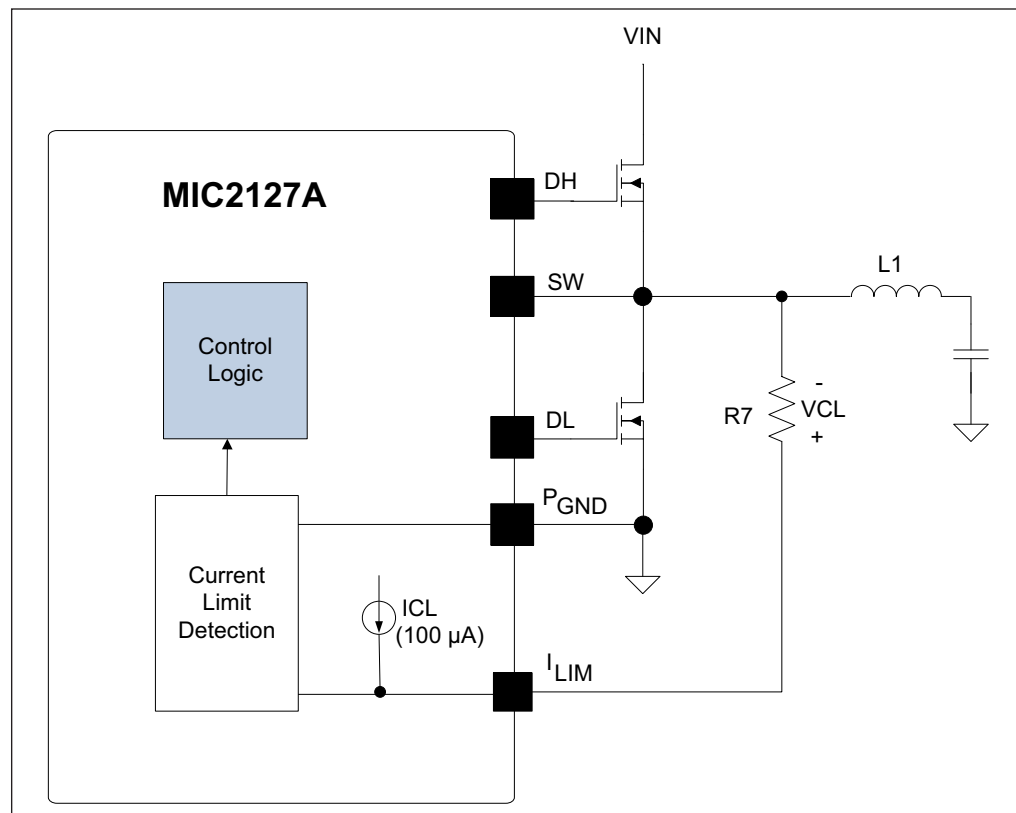

**FIGURE 2-1:** Switching Frequency Adjustment.

# MIC2127A Evaluation Board User's Guide

---

The ILIM pin voltage ( $V_{ILIM}$ ) is the difference of the voltage across the low-side MOSFET and the voltage across the resistor ( $V_{CL}$ ). The sensed voltage  $V_{ILIM}$  is compared with the power ground ( $P_{GND}$ ) after a blanking time of 150 ns.

If the absolute value of the voltage drop across the low-side MOSFET is greater than the absolute value of the voltage across the current setting resistor ( $V_{CL}$ ), the MIC2127A triggers the current limit event. Consecutive eight current limit events trigger the Hiccup mode. The hiccup sequence, including the soft start, reduces the stress on the switching field-effect transistors (FETs) and protects the load and supply from severe short conditions.

The current limit can be programmed by modifying the R7 resistor according to Equation 2-3:

## EQUATION 2-3: EQUATION 3

$$R_7 = \frac{\left(I_{CLIM} + \frac{\Delta I_{LPP}}{2}\right) \times R_{DS(ON)} + V_{offset}}{I_{CL}}$$

where:

- $I_{CLIM}$  = Desired current limit
- $\Delta I_{LPP}$  = Inductor peak-to-peak ripple current
- $R_{DS(ON)}$  = On resistance of low-side power MOSFET
- $V_{offset}$  = Current-limit comparator offset. Maximum value is +15 mV.
- $I_{CL}$  = Current-limit source current. Typical value is 100  $\mu$ A.

It is mandatory to make sure that the peak inductor current during soft start, which includes the output capacitor charging current along with load current, is under the current limit, otherwise the supply will go in Hiccup mode and may not finish the soft start successfully.

The MOSFET  $R_{DS(ON)}$  varies 30% to 40% with temperature. Therefore, it is recommended to add a 30% margin to  $I_{CL}$  in the above equation to avoid false current limiting due to increased MOSFET junction temperature rise. It is also recommended to connect the SW pin directly to the drain of the low-side MOSFET to accurately sense the MOSFET's  $R_{DS(ON)}$ .

To improve the current limit variation, the MIC2127A adjusts the internal current limit source current ( $I_{CL}$ ) at a rate of 0.3  $\mu$ A/ $^{\circ}$ C when the MIC2127A junction temperature changes to compensate the  $R_{DS(ON)}$  variation of external low side MOSFET. The effectiveness of this method depends on the thermal gradient between the MIC2127A and the external low side MOSFET. The lower the thermal gradient is, the better the current limit variation is.

## 2.3.7 Setting the Switching Frequency

The MIC2127A is an adjustable-frequency, synchronous buck controller. The switching frequency can be adjusted between 270 kHz and 800 kHz by changing the resistor divider network consisting of R2 and R3.

The following formula provides the estimated switching frequency:

### EQUATION 2-4: EQUATION 4

$$f_{SW} = f_o \times \frac{R3}{R2 + R3}$$

where:

$f_o$  = Switching Frequency when R2 is 100K and R3 is open,  $f_o$  is typically 800 kHz. For a more precise setting, it is recommended to use the Switching Frequency graph from the data sheet.

The evaluation board design is optimized for a switching frequency of 300 kHz. If the switching frequency is programmed to either lower end or higher end, the design needs optimization. The switching frequency adjustment is depicted in [Figure 2-2](#):

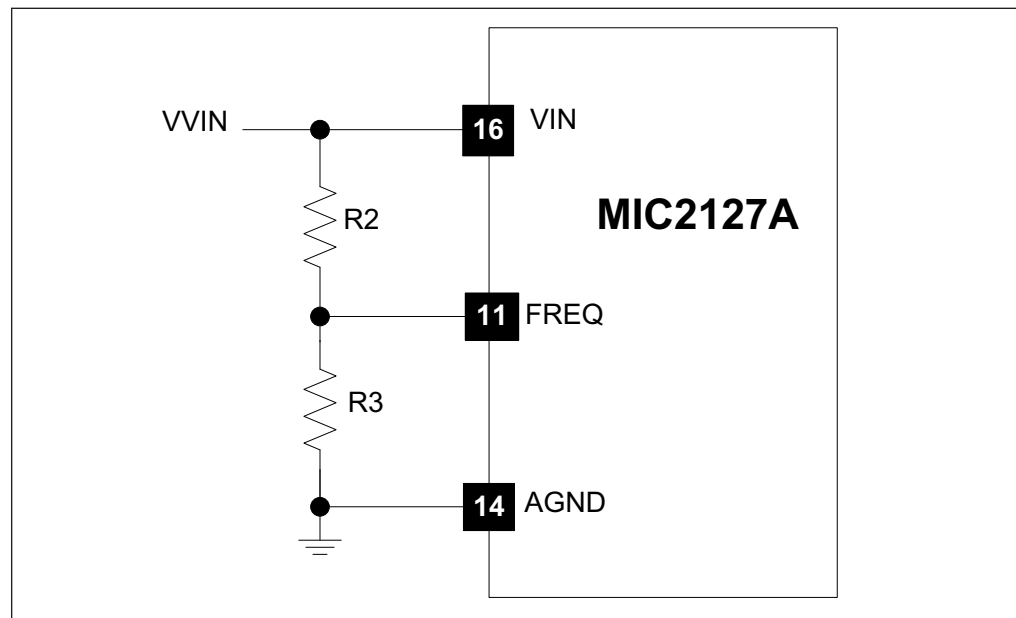

**FIGURE 2-2:** Switching Frequency Adjustment.

## 2.3.8 Loop Gain Measurement

The resistor R14, which is in series with the feedback divider, can be used for loop gain measurements. For loop gain measurements, replace R14 by a 20Ω to 50Ω resistor and apply network analyzer signal source across it. Use the end of R14, which is connected to VOUT, with respect to A<sub>GND</sub> as output and the other end of R14, with respect to A<sub>GND</sub> as input for loop gain measurement.

# MIC2127A Evaluation Board User's Guide

---

NOTES:

---

---

## Appendix A. Schematic and Layouts

---

---

### A.1 INTRODUCTION

This appendix contains the following schematics and layouts for the MIC2127A Evaluation Board:

- Board – Schematic
- Board – Top Silk Layer
- Board – Top Copper Layer
- Board – Mid Copper Layer 1
- Board – Mid Copper Layer 2
- Board – Bottom Copper Layer
- Board – Bottom Silk Layer

## A.2 BOARD – SCHEMATIC

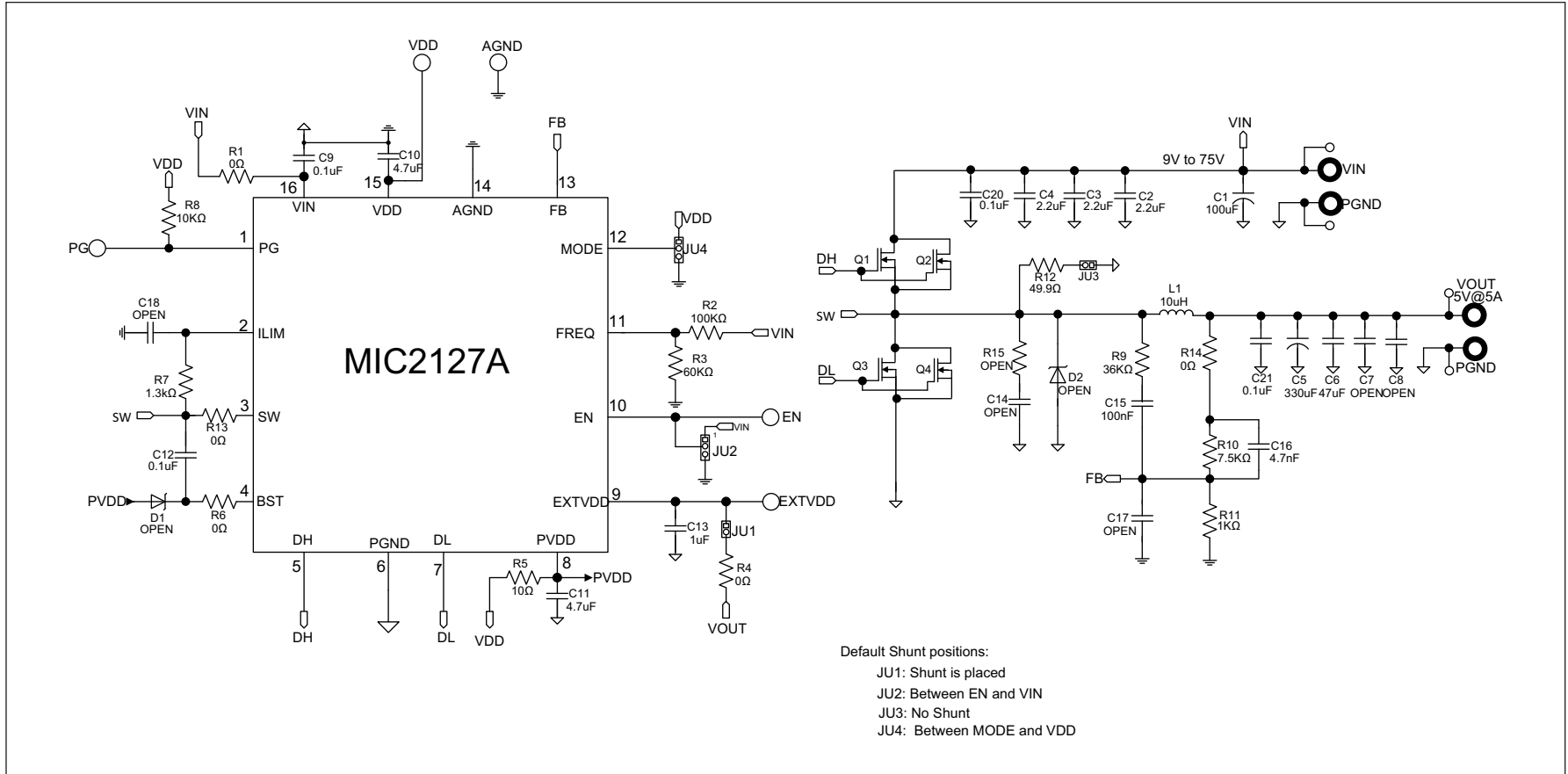

## A.3 BOARD – TOP SILK LAYER

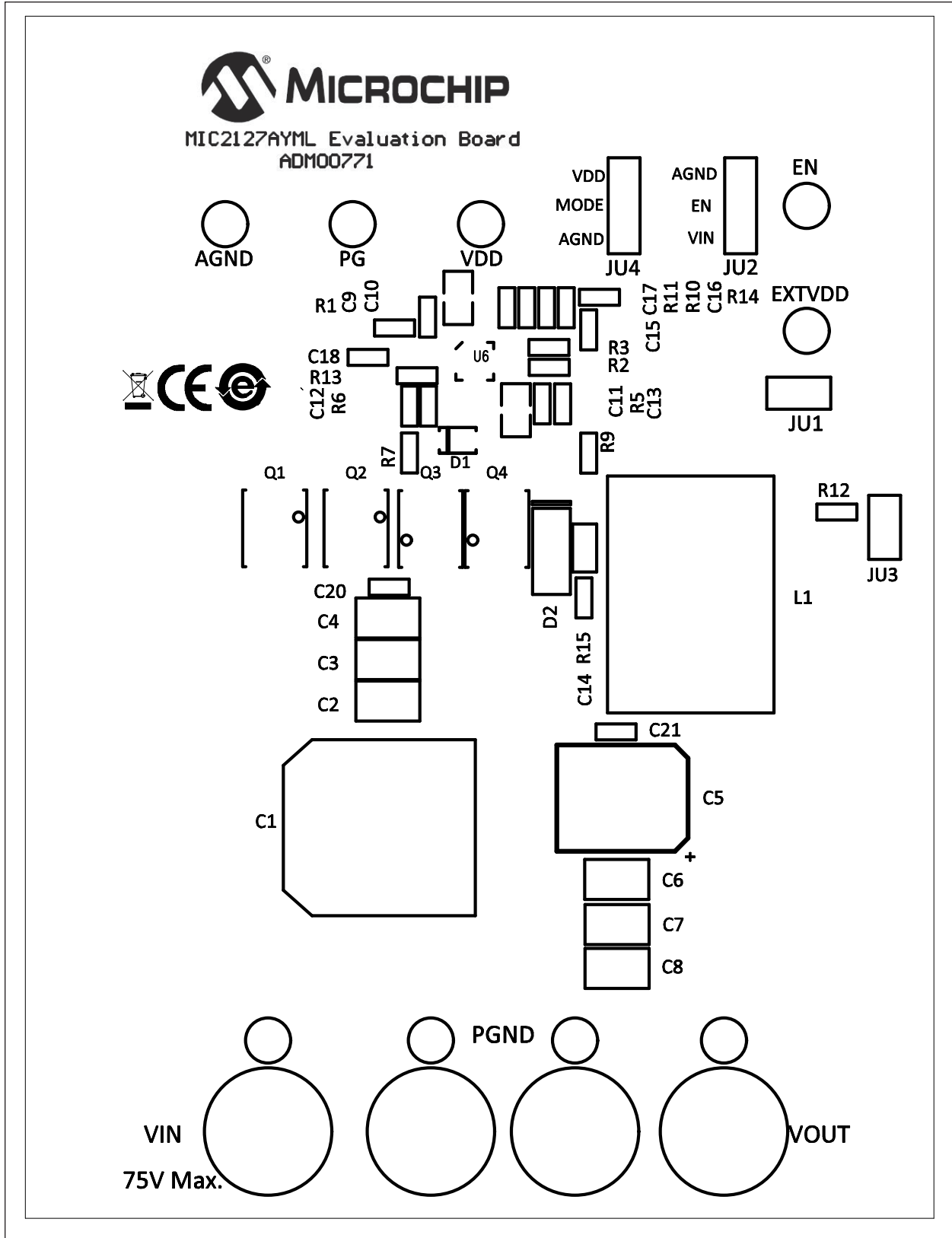

# MIC2127A Evaluation Board User's Guide

## A.4 BOARD – TOP COPPER LAYER

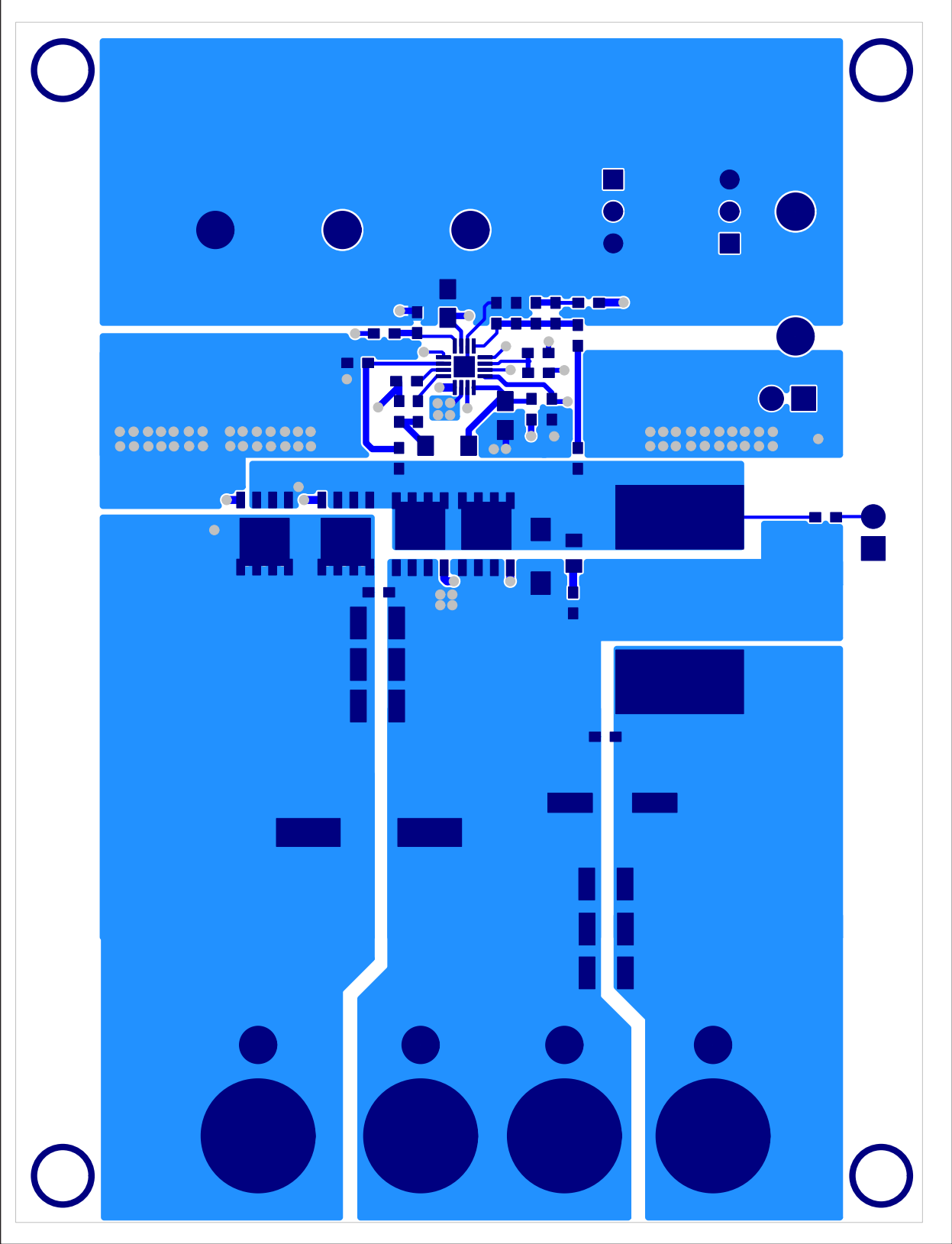

## A.5 BOARD – MID COPPER LAYER 1

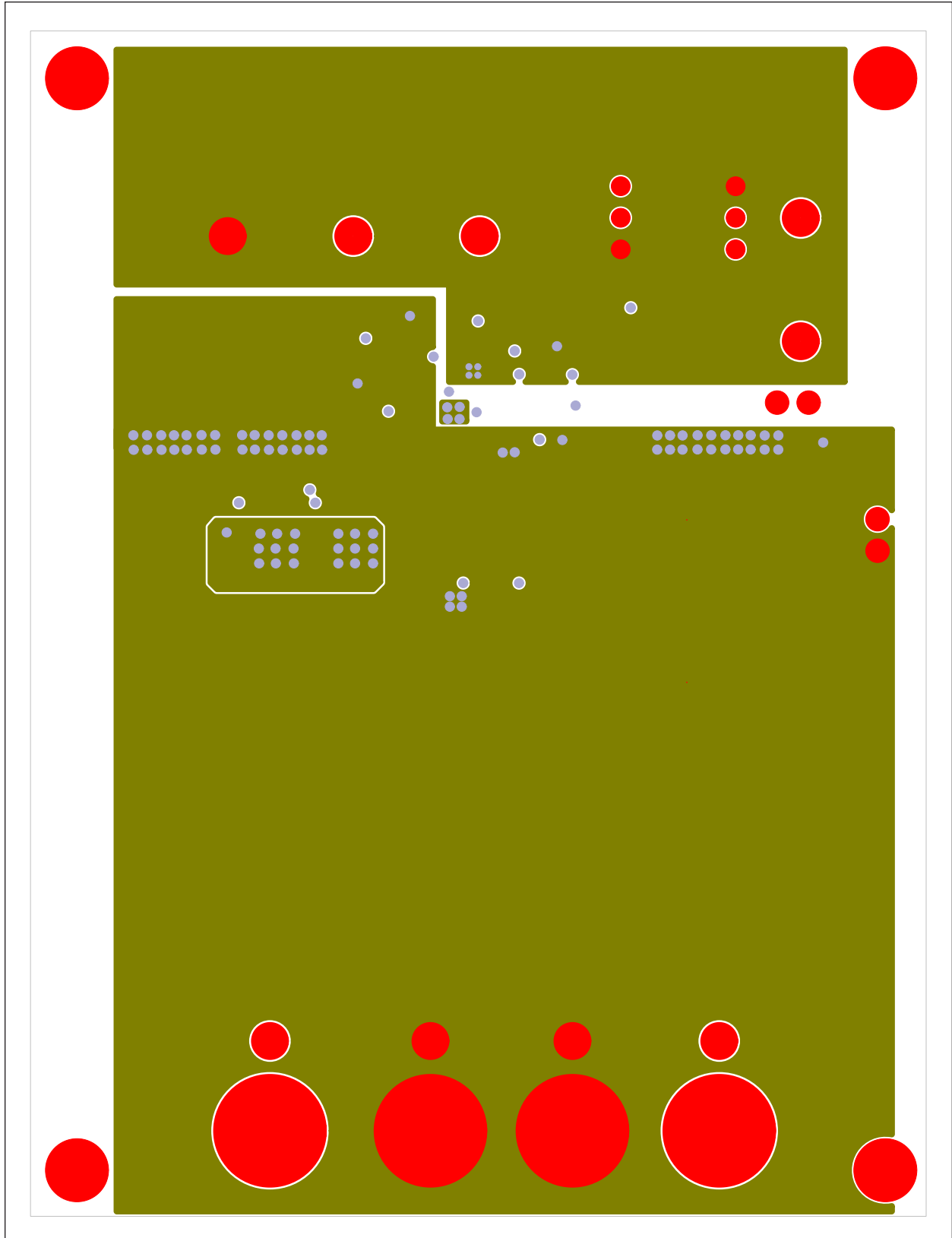

# MIC2127A Evaluation Board User's Guide

## A.6 BOARD – MID COPPER LAYER 2

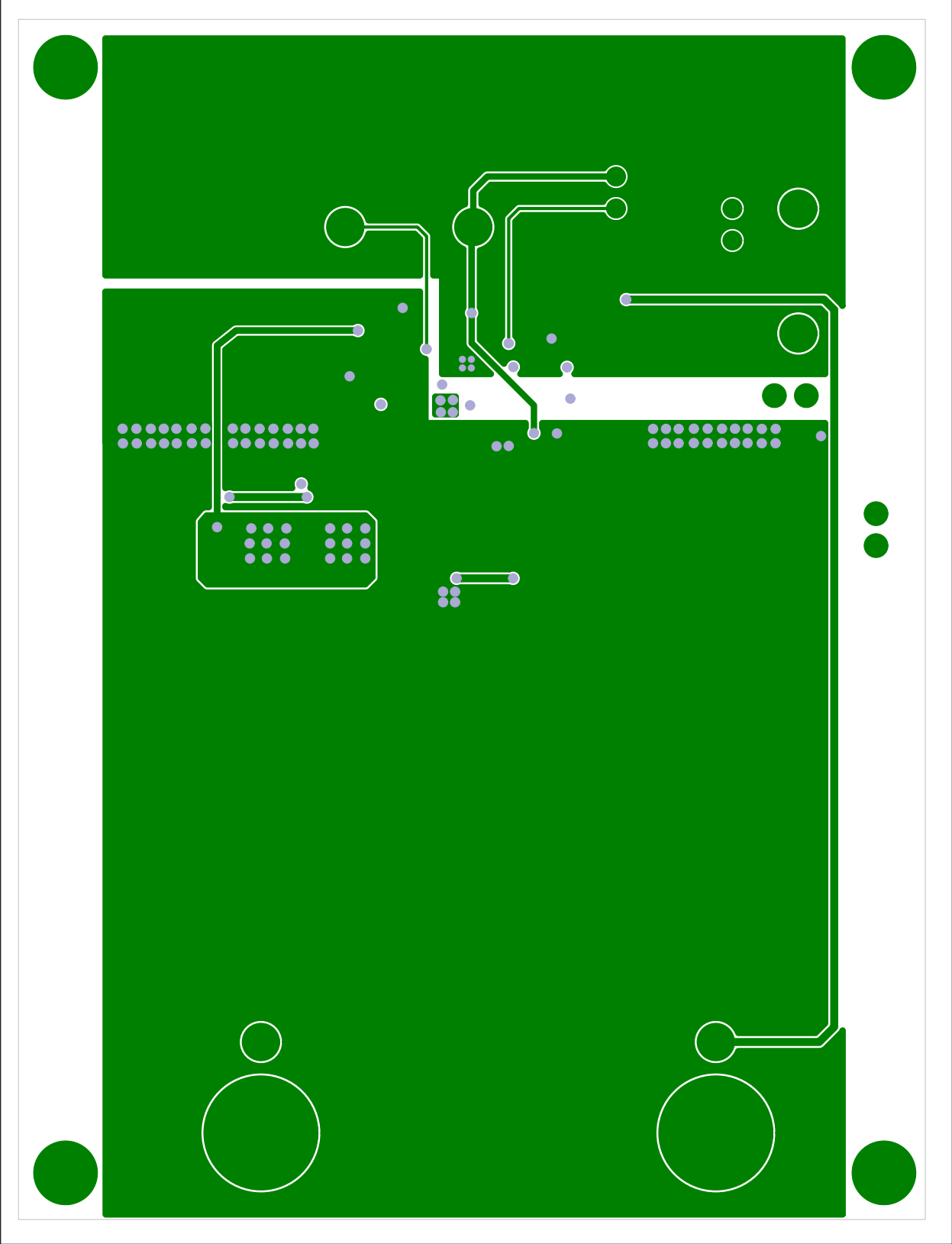

## A.7 BOARD – BOTTOM COPPER LAYER

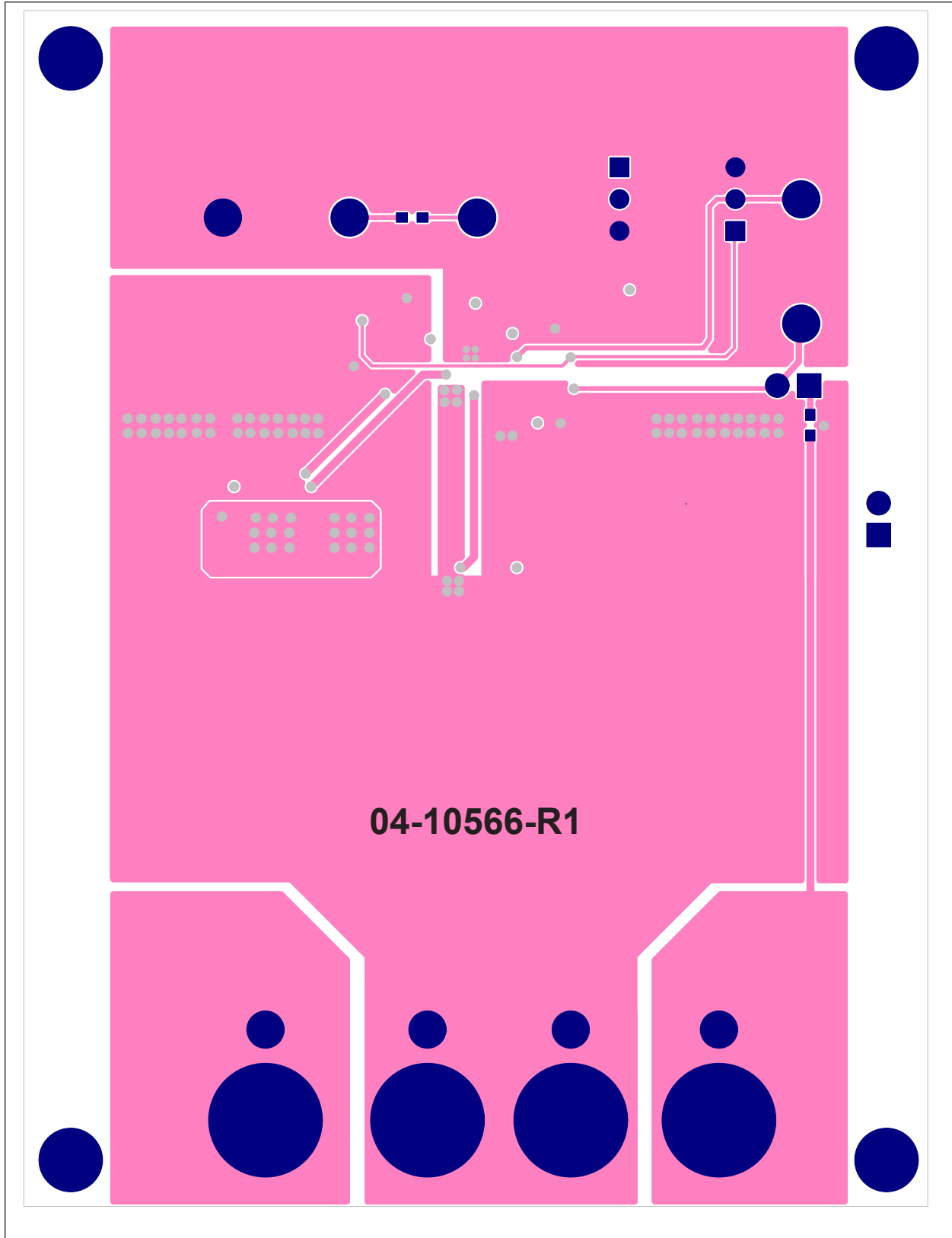

# MIC2127A Evaluation Board User's Guide

---

## A.8 BOARD – BOTTOM SILK LAYER

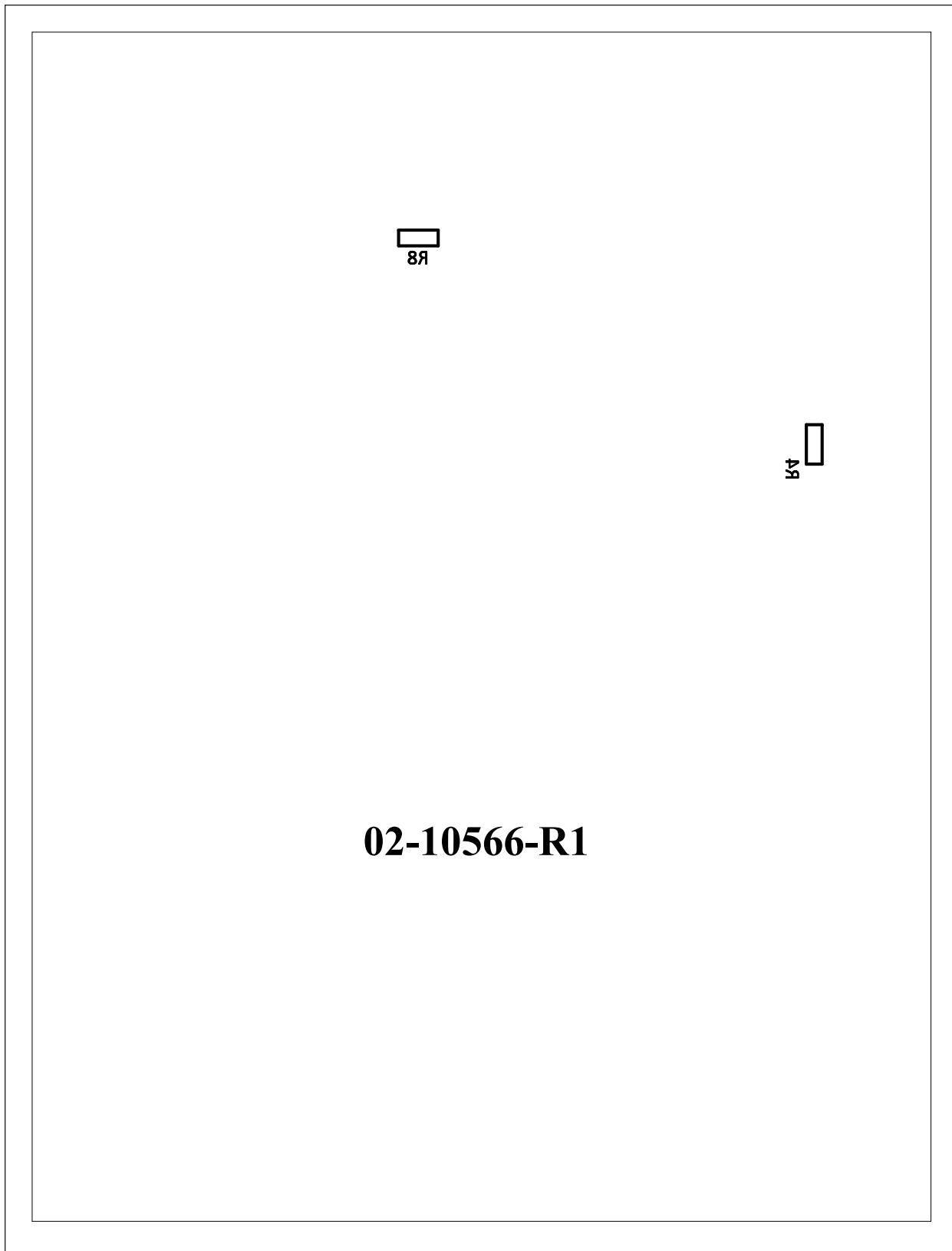

## Appendix B. Bill of Materials (BOM)

**TABLE B-1: BILL OF MATERIALS (BOM)**

Qty.	Reference	Description	Manufacturer	Part Number
1	C1	Capacitor electrolytic 100 $\mu$ F, 100V, 20%, 330 m $\Omega$	United Chemi-Con	EMVY101ARA101MKE0S
3	C2, C3, C4	Capacitor ceramic 2.2 $\mu$ F, X7R, 100V, 10%	Murata Electronics North America, Inc.	GRM32ER72A225K
1	C5	Capacitor electrolytic 330 $\mu$ F, 10V, 17 m $\Omega$	Panasonic® - ECG	10SVP330M
1	C6	Capacitor ceramic 47 $\mu$ F, X7R, 10V, 10%	Murata Electronics North America, Inc.	GRM32ER71A476K
3	C9, C15, C20	Capacitor ceramic 0.1 $\mu$ F, X7R, 100V, 10%	Murata Electronics North America, Inc.	GRM188R72A104K
2	C10, C11	Capacitor ceramic 4.7 $\mu$ F, X7R, 10V, 10%	Murata Electronics North America, Inc.	GRM21BR71A475KA73K
2	C12, C21	Capacitor ceramic 0.1 $\mu$ F, X7R, 16V, 10%	Murata Electronics North America, Inc.	GRM188R71C104K
1	C13	Capacitor ceramic 1 $\mu$ F, X7R, 10V, 10%	Murata Electronics North America, Inc.	GRM188R71A105K
1	C16	Capacitor ceramic 4.7 nF, X7R, 1 6V	Murata Electronics North America, Inc.	GRM188R71C472KA
1	PCB	Printed Circuit Board - MIC2127A Evaluation Board	—	<b>02-10566</b>
5	R1,R4,R6,R13,R14	0 $\Omega$ , 0603 size resistor	Yageo Corporation	RC0603FR-070RL
1	R2	100K, 0603 size resistor	Yageo Corporation	RC0603FR-07100KL
1	R3	60K, 0603 size resistor	Yageo Corporation	RC0603FR-0760K4L
1	R5	10 $\Omega$ , 0603 size resistor	Yageo Corporation	RC0603FR-0710RL
1	R7	1.3K, 0603 size resistor	Yageo Corporation	RC0603FR-071K3L
1	R8	10K, 0603 size resistor	Yageo Corporation	RC0603FR-0710KL
1	R9	36K, 0603 size resistor	Yageo Corporation	RC0603FR-0718KL
1	R10	7.5K, 0603 size resistor	Yageo Corporation	RC0603FR-077K5L
1	R11	1K, 0603 size resistor	Yageo Corporation	RC0603FR-071KL
1	R12	49.9 $\Omega$ , 0603 size resistor	Yageo Corporation	RC0603FR-0749R9L
2	JU1, JU3	2-pin header (100 mil pitch)	TE Connectivity, Ltd.	5-146278-2
2	JU2, JU4	3-pin header (100 mil pitch)	TE Connectivity, Ltd.	5-146282-3
9	PG, AGND, VDD, EN, EXTVD, VIN, PGND, VOUT, PGND	Terminal double turret (through hole, noninsulated)	Keystone Electronics Corp.	1593-2

**Note 1:** The components listed in this Bill of Materials are representative of the PCB assembly. The released BOM used in manufacturing uses all RoHS-compliant components.

# MIC2127A Evaluation Board User's Guide

**TABLE B-1: BILL OF MATERIALS (BOM) (CONTINUED)**

Qty.	Reference	Description	Manufacturer	Part Number
1	L1	10 $\mu$ H inductor, size 13.5 mm X 12.5 mm X 6.2 mm	Bourns <sup>®</sup> , Inc.	SRP1265A-100M
2	Q2, Q3	100V, 40A N-Channel MOSFET, power PAK S08 (5.15 mm X 6.15 mm)	Vishay Intertechnology, Inc.	SIR878ADP
4	VIN, PGND, VOUT, PGND	Noninsulated banana jack	Keystone Electronics	575-4
2	Shunt	Shunts with closed top, (100 mil pitch)	Sullins Connector Solutions	SPC02SYAN

**Note 1:** The components listed in this Bill of Materials are representative of the PCB assembly. The released BOM used in manufacturing uses all RoHS-compliant components.

**TABLE B-2: BILL OF MATERIALS (BOM) - DO NOT POPULATE**

Qty.	Reference	Description	Manufacturer	Part Number
0	C7, C8	1210 mm size MLCC capacitor	—	—
0	C14	0603 size capacitor	—	—
0	C17	0603 size MLCC capacitor	—	—
0	C18	0603 size MLCC capacitor	—	—
0	D1	100V Schottky diode, power SOD123	—	—
0	D2	100V Schottky diode, power PAK S08 (5.15 mm X 6.15 mm)	—	—
0	R15	0805 size resistor	—	—
0	Q1, Q4	N-Channel MOSFET, power PAK S08 (5.15 mm X 6.15 mm)	—	—

**Note 1:** The components listed in this Bill of Materials are representative of the PCB assembly. The released BOM used in manufacturing uses all RoHS-compliant components.



# MICROCHIP

## Worldwide Sales and Service

### AMERICAS

**Corporate Office**  
2355 West Chandler Blvd.  
Chandler, AZ 85224-6199  
Tel: 480-792-7200  
Fax: 480-792-7277  
Technical Support:  
<http://www.microchip.com/support>  
Web Address:  
[www.microchip.com](http://www.microchip.com)

**Atlanta**  
Duluth, GA  
Tel: 678-957-9614  
Fax: 678-957-1455

**Austin, TX**  
Tel: 512-257-3370

**Boston**  
Westborough, MA  
Tel: 774-760-0087  
Fax: 774-760-0088

**Chicago**  
Itasca, IL  
Tel: 630-285-0071  
Fax: 630-285-0075

**Dallas**  
Addison, TX  
Tel: 972-818-7423  
Fax: 972-818-2924

**Detroit**  
Novi, MI  
Tel: 248-848-4000

**Houston, TX**  
Tel: 281-894-5983

**Indianapolis**  
Noblesville, IN  
Tel: 317-773-8323  
Fax: 317-773-5453  
Tel: 317-536-2380

**Los Angeles**  
Mission Viejo, CA  
Tel: 949-462-9523  
Fax: 949-462-9608  
Tel: 951-273-7800

**Raleigh, NC**  
Tel: 919-844-7510

**New York, NY**  
Tel: 631-435-6000

**San Jose, CA**  
Tel: 408-735-9110  
Tel: 408-436-4270

**Canada - Toronto**  
Tel: 905-695-1980  
Fax: 905-695-2078

### ASIA/PACIFIC

**Australia - Sydney**  
Tel: 61-2-9868-6733

**China - Beijing**  
Tel: 86-10-8569-7000

**China - Chengdu**  
Tel: 86-28-8665-5511

**China - Chongqing**  
Tel: 86-23-8980-9588

**China - Dongguan**  
Tel: 86-769-8702-9880

**China - Guangzhou**  
Tel: 86-20-8755-8029

**China - Hangzhou**  
Tel: 86-571-8792-8115

**China - Hong Kong SAR**  
Tel: 852-2943-5100

**China - Nanjing**  
Tel: 86-25-8473-2460

**China - Qingdao**  
Tel: 86-532-8502-7355

**China - Shanghai**  
Tel: 86-21-3326-8000

**China - Shenyang**  
Tel: 86-24-2334-2829

**China - Shenzhen**  
Tel: 86-755-8864-2200

**China - Suzhou**  
Tel: 86-186-6233-1526

**China - Wuhan**  
Tel: 86-27-5980-5300

**China - Xian**  
Tel: 86-29-8833-7252

**China - Xiamen**  
Tel: 86-592-2388138

**China - Zhuhai**  
Tel: 86-756-3210040

### ASIA/PACIFIC

**India - Bangalore**  
Tel: 91-80-3090-4444

**India - New Delhi**  
Tel: 91-11-4160-8631

**India - Pune**  
Tel: 91-20-4121-0141

**Japan - Osaka**  
Tel: 81-6-6152-7160

**Japan - Tokyo**  
Tel: 81-3-6880-3770

**Korea - Daegu**  
Tel: 82-53-744-4301

**Korea - Seoul**  
Tel: 82-2-554-7200

**Malaysia - Kuala Lumpur**  
Tel: 60-3-7651-7906

**Malaysia - Penang**  
Tel: 60-4-227-8870

**Philippines - Manila**  
Tel: 63-2-634-9065

**Singapore**  
Tel: 65-6334-8870

**Taiwan - Hsin Chu**  
Tel: 886-3-577-8366

**Taiwan - Kaohsiung**  
Tel: 886-7-213-7830

**Taiwan - Taipei**  
Tel: 886-2-2508-8600

**Thailand - Bangkok**  
Tel: 66-2-694-1351

**Vietnam - Ho Chi Minh**  
Tel: 84-28-5448-2100

### EUROPE

**Austria - Wels**  
Tel: 43-7242-2244-39  
Fax: 43-7242-2244-393

**Denmark - Copenhagen**  
Tel: 45-4450-2828  
Fax: 45-4485-2829

**Finland - Espoo**  
Tel: 358-9-4520-820

**France - Paris**  
Tel: 33-1-69-53-63-20  
Fax: 33-1-69-30-90-79

**Germany - Garching**  
Tel: 49-8931-9700

**Germany - Haan**  
Tel: 49-2129-3766400

**Germany - Heilbronn**  
Tel: 49-7131-72400

**Germany - Karlsruhe**  
Tel: 49-721-625370

**Germany - Munich**  
Tel: 49-89-627-144-0  
Fax: 49-89-627-144-44

**Germany - Rosenheim**  
Tel: 49-8031-354-560

**Israel - Ra'anana**  
Tel: 972-9-744-7705

**Italy - Milan**  
Tel: 39-0331-742611  
Fax: 39-0331-466781

**Italy - Padova**  
Tel: 39-049-7625286

**Netherlands - Drunen**  
Tel: 31-416-690399  
Fax: 31-416-690340

**Norway - Trondheim**  
Tel: 47-7288-4388

**Poland - Warsaw**  
Tel: 48-22-3325737

**Romania - Bucharest**  
Tel: 40-21-407-87-50

**Spain - Madrid**  
Tel: 34-91-708-08-90  
Fax: 34-91-708-08-91

**Sweden - Gothenberg**  
Tel: 46-31-704-60-40

**Sweden - Stockholm**  
Tel: 46-8-5090-4654

**UK - Wokingham**  
Tel: 44-118-921-5800  
Fax: 44-118-921-5820