

Introduction

The AVR® EB Family of microcontrollers uses the AVR® CPU with hardware multiplier running at clock speeds up to 20 MHz, with up to 32 KB of Flash, up to 3 KB of SRAM, and 512 bytes of EEPROM in 14-, 20-, 28- or 32-pin packages. The AVR® EB Family uses the latest technology from Microchip with a flexible and low-power architecture, including an Event System, accurate analog subsystems, and advanced digital peripherals.

Family Overview

The figure below shows the AVR® EB Family of devices, laying out pin count variants and memory sizes:

- Vertical migration is possible without code modification, as these devices are fully pin and feature compatible
- Horizontal migration to the left reduces the pin count and, therefore, the available features

Figure 1. AVR® EB Family Overview

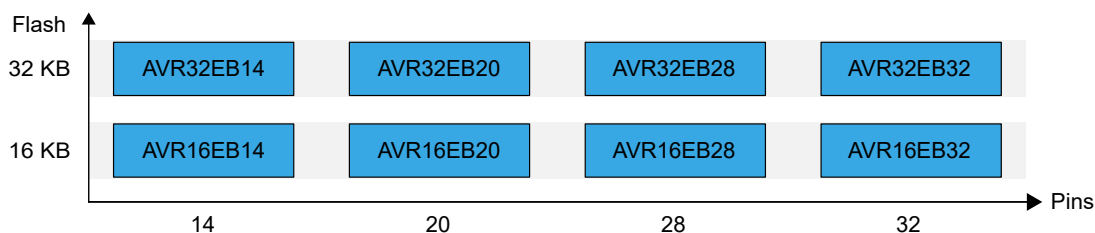

Devices with different Flash memory sizes typically also have different SRAM sizes.

A device name in the AVR® EB Family decodes as follows:

Figure 2. AVR® EB Family Device Designations

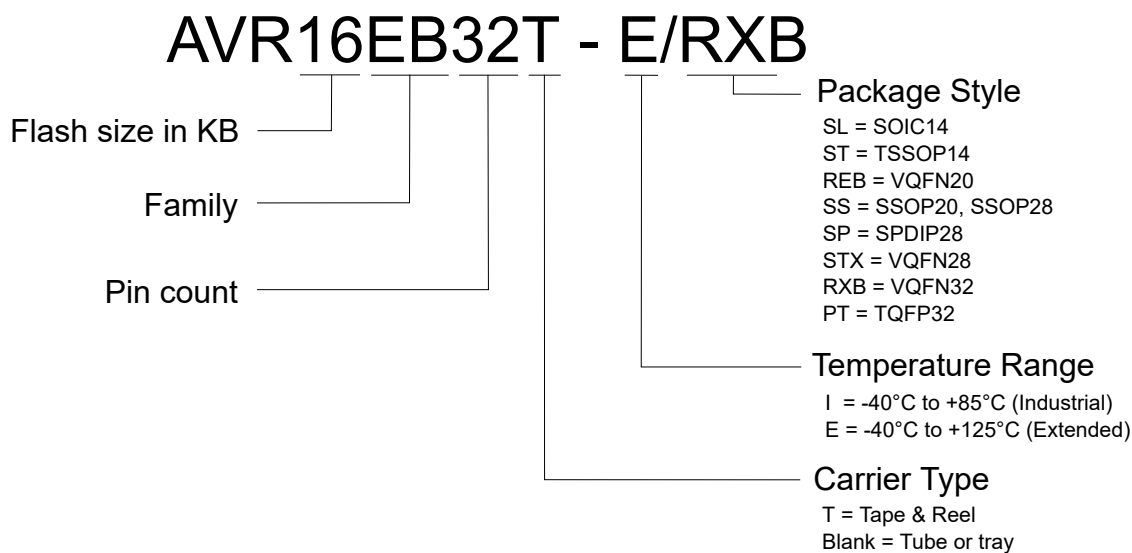

Memory Overview

Table 1. Memory Overview

Devices	AVR16EB14	AVR32EB14
	AVR16EB20	AVR32EB20
	AVR16EB28	AVR32EB28
	AVR16EB32	AVR32EB32
Flash memory	16 KB	32 KB
SRAM	2 KB	3 KB
EEPROM	512B	512B
User row	64B	64B
Boot row	64B	64B

Peripheral Overview

Table 2. Peripheral Overview

Feature	AVR16EB14	AVR16EB20	AVR16EB28	AVR16EB32
	AVR32EB14	AVR32EB20	AVR32EB28	AVR32EB32
Pins	14	20	28	32
Max. frequency (MHz)	20	20	20	20
16-bit Timer/Counter type B (TCB)	2	2	2	2
16-bit Timer/Counter type E (TCE)	1	1	1	1
Waveform Extension (WEX)	1	1	1	1
16-bit Timer/Counter type F (TCF)	1	1	1	1
Real-Time Counter (RTC)	1	1	1	1
USART/SPI host	1	1	1	1
SPI host/client	1	1	1	1
TWI/I ² C ⁽¹⁾	1	1	1	1

.....continued

Feature	AVR16EB14	AVR16EB20	AVR16EB28	AVR16EB32
	AVR32EB14	AVR32EB20	AVR32EB28	AVR32EB32
12-bit differential ADC (channels)	1 (8)	1 (14)	1 (20)	1 (24)
Analog Comparator (AC)	2	2	2	2
Configurable Custom Logic Look-up Table (CCL LUT)	4	4	4	4
Watchdog Timer	1	1	1	1
Event System channels	6	6	6	6
General Purpose I/O pins (input/output ⁽²⁾)	12/11	18/17	24/23	28/27
PORT	PA[1:0] PC[3:0] PD[7:4] PF[7:6]	PA[7:0] PC[3:0] PD[7:4] PF[7:6]	PA[7:0] PC[3:0] PD[7:0] PF[7,6,1,0]	PA[7:0] PC[3:0] PD[7:0] PF[7:0]
External interrupts	12	18	24	28
CRCSCAN	1	1	1	1
Unified Program and Debug Interface (UPDI)	1	1	1	1

Notes:

1. The TWI/I²C can operate simultaneously as a host and client on different pins.
2. PF6/RESET pin is input only.

Features

- AVR® CPU
 - Running at up to 20 MHz
 - Single-cycle I/O register access
 - Two-level interrupt controller
 - Two-cycle hardware multiplier
 - Supply voltage range: 1.8-5.5V
- Memories
 - 16/32 KB In-system-programmable Flash memory with a true read-while-write operation
 - 2/3 KB SRAM
 - 512B EEPROM
 - 64B of user row in nonvolatile memory that can keep data during chip-erase and be programmed while the device is locked
 - Write/erase endurance
 - Flash: 1,000 cycles
 - EEPROM: 100,000 cycles
 - Data retention: 40 Years at 55°C
- System
 - Power-on Reset (POR) circuit
 - Brown-out Detector (BOD) with user-programmable levels
 - Voltage Level Monitor (VLM) with interrupt at a programmable level above the BOD level
 - Clock options:
 - High-precision internal oscillator with selectable frequency up to 20 MHz (OSCHF)
 - Auto-tuning for improved internal oscillator accuracy
 - Internal PLL up to 80 MHz for high-frequency operation of Timer/Counter type E/F
 - Internal ultra-low power 32.768 kHz oscillator (OSC32K)
 - External 32.768 kHz crystal oscillator (XOSC32K)
 - External clock input
 - Single-pin Unified Program and Debug Interface (UPDI)
 - Three sleep modes
 - Idle with all peripherals running for immediate wake-up
 - Standby with a configurable operation of selected peripherals
 - Power-Down with full data retention
- Peripherals
 - Two 16-bit Timer/Counters type B (TCB) with input capture for capture and signal measurements
 - One 16-bit Timer/Counter type E (TCE) with four compare channels for PWM generation and Waveform Extension (WEX)
 - One 24-bit Timer/Counter type F (TCF) for frequency generation
 - One 16-bit Real-Time Counter (RTC) that can run from an external crystal or internal oscillator
 - One USART with fractional baud rate generator, auto-baud, and start-of-frame detection
 - One host/client Serial Peripheral Interface (SPI)

- One Two-Wire Interface (TWI) with dual address match
 - Independent host and client operation (Dual mode)
 - Phillips I²C compatible
 - Standard mode (Sm, 100 kHz)
 - Fast mode (Fm, 400 kHz)
 - Fast mode plus (Fm+, 1 MHz)
- Event System for CPU-independent and predictable inter-peripheral signaling
- Configurable Custom Logic (CCL) with up to four programmable Look-up Tables (LUTs)
- One 12-bit, 300 ksps, differential Analog-to-Digital Converter (ADC) with a programmable gain amplifier (PGA)
- Two Analog Comparators (ACs) with window compare functions
- Multiple voltage references (VREF)
 - 1.024V
 - 2.048V
 - 2.500V
 - 4.096V
 - VREFA
 - V_{DD}
- Automated Cyclic Redundancy Check (CRC) Flash program memory scan
- Watchdog Timer (WDT) with Window mode and separate on-chip oscillator
- External interrupt on all general purpose pins
- I/O and Packages:
 - Up to 28/27 programmable I/O pins
 - 14-pin SOIC and TSSOP
 - 20-pin SSOP and VQFN
 - 28-pin SPDIP, SSOP and VQFN
 - 32-pin VQFN and TQFP
- Temperature Ranges
 - Industrial: -40°C to 85°C ambient
 - Extended: -40°C to 125°C ambient

Table of Contents

Introduction.....	1
Family Overview.....	1
Memory Overview.....	2
Peripheral Overview.....	2
Features.....	4
1. Block Diagram.....	7
2. Pinout.....	8
2.1. 14-Pin SOIC and TSSOP.....	8
2.2. 20-Pin SSOP.....	8
2.3. 20-Pin VQFN.....	9
2.4. 28-Pin SPDIP and SSOP.....	10
2.5. 28-Pin VQFN.....	11
2.6. 32-Pin VQFN and TQFP.....	12
3. I/O Multiplexing and Considerations.....	13
3.1. I/O Multiplexing.....	13
4. Revision History.....	15
Microchip Information.....	16
The Microchip Website.....	16
Product Change Notification Service.....	16
Customer Support.....	16
Microchip Devices Code Protection Feature.....	16
Legal Notice.....	16
Trademarks.....	17
Quality Management System.....	18
Worldwide Sales and Service.....	19

1. Block Diagram

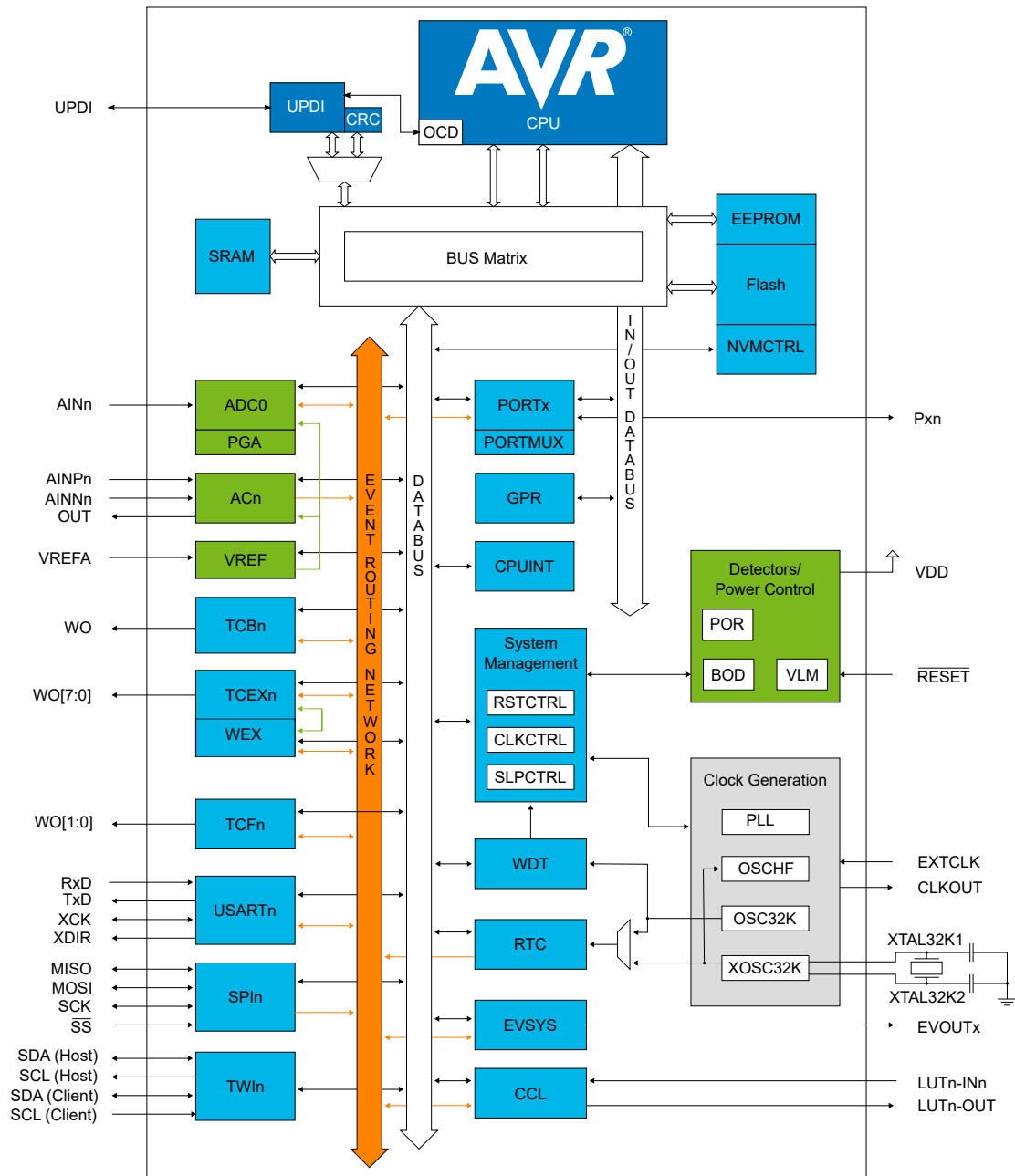

2. Pinout

2.1 14-Pin SOIC and TSSOP

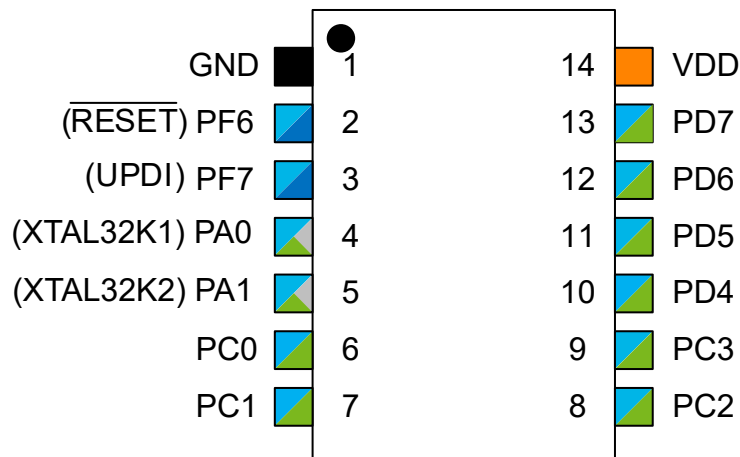

Power

- Power Supply
- Ground
- Pin on VDD Power Domain



Functionality

- Programming/Debug
- Clock/Crystal
- Digital Function Only
- Analog Function

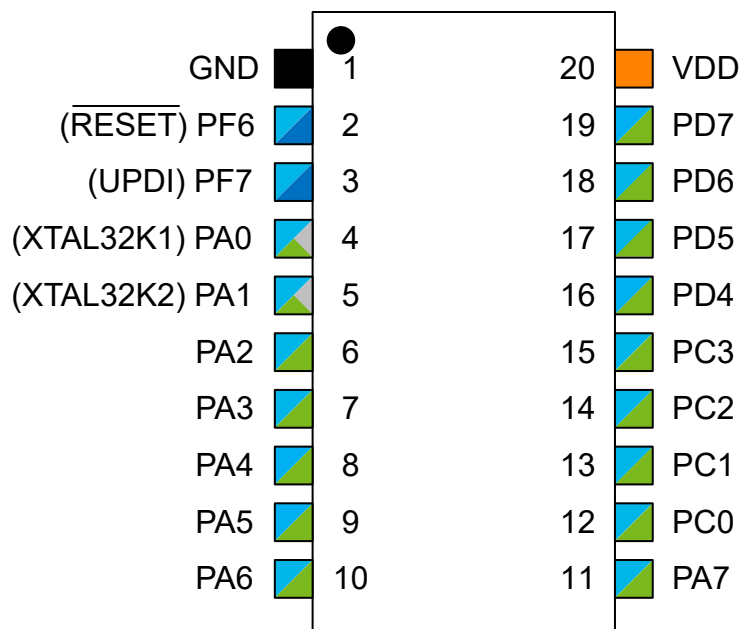



2.2 20-Pin SSOP



Power

-  Power Supply
-  Ground
-  Pin on VDD Power Domain



Functionality

-  Programming/Debug
-  Clock/Crystal
-  Digital Function Only
-  Analog Function

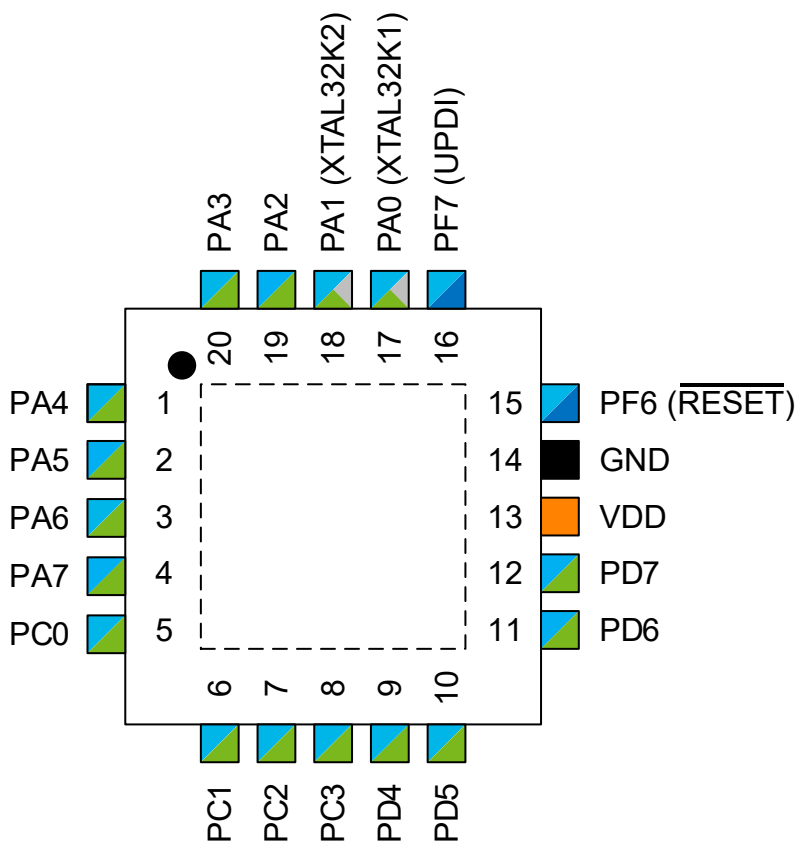



2.3 20-Pin VQFN



Power

-  Power Supply
-  Ground
-  Pin on VDD Power Domain



Functionality

-  Programming/Debug
-  Clock/Crystal
-  Digital Function Only
-  Analog Function

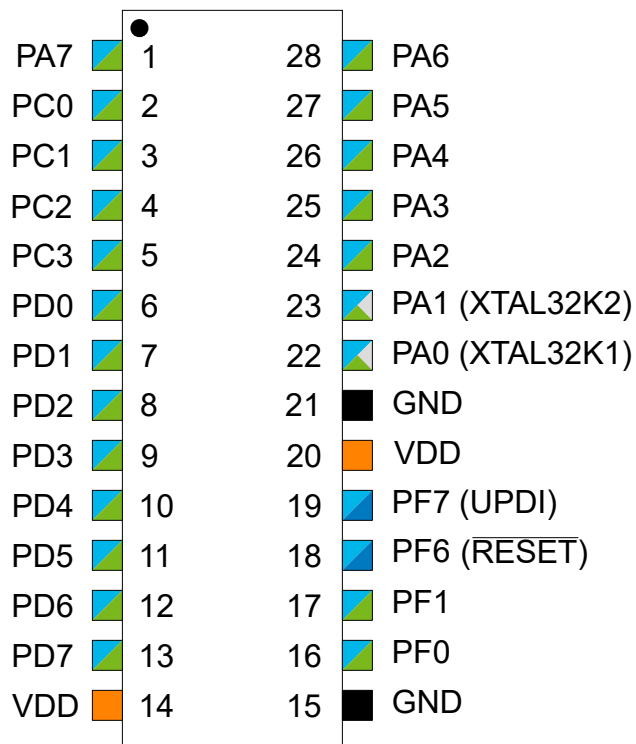



2.4 28-Pin SPDIP and SSOP



Power

-  Power Supply
-  Ground
-  Pin on VDD Power Domain



Functionality

-  Programming/Debug
-  Clock/Crystal
-  Digital Function Only
-  Analog Function

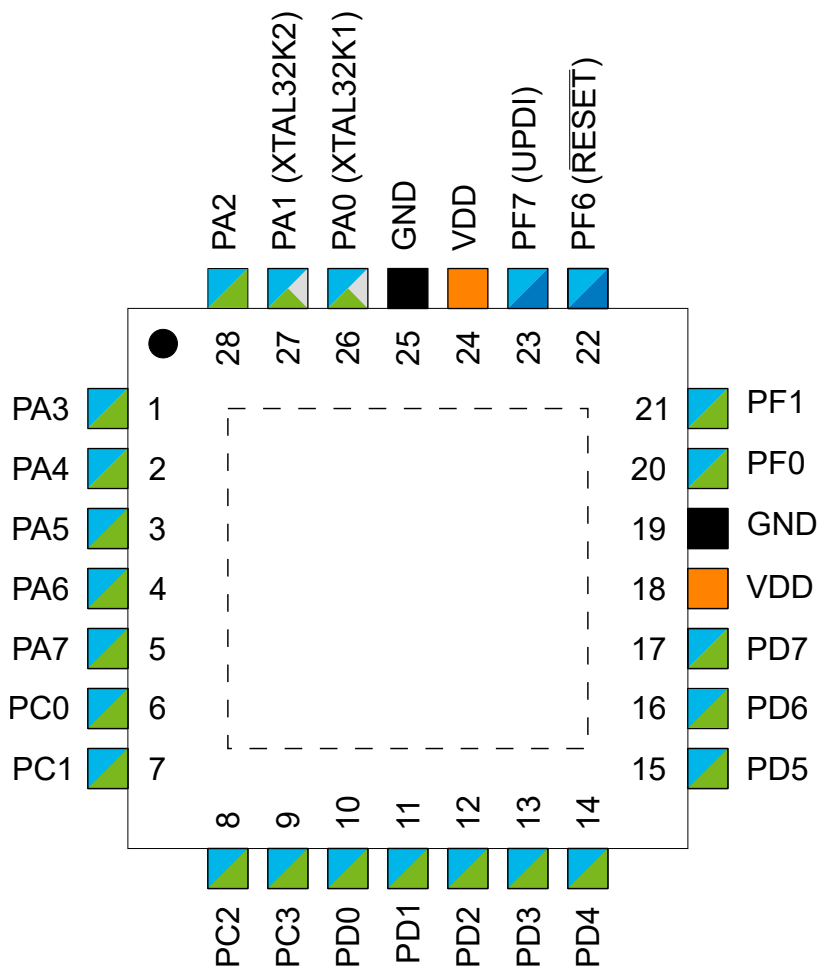



2.5 28-Pin VQFN



Power

-  Power Supply
-  Ground
-  Pin on VDD Power Domain



Functionality

-  Programming/Debug
-  Clock/Crystal
-  Digital Function Only
-  Analog Function

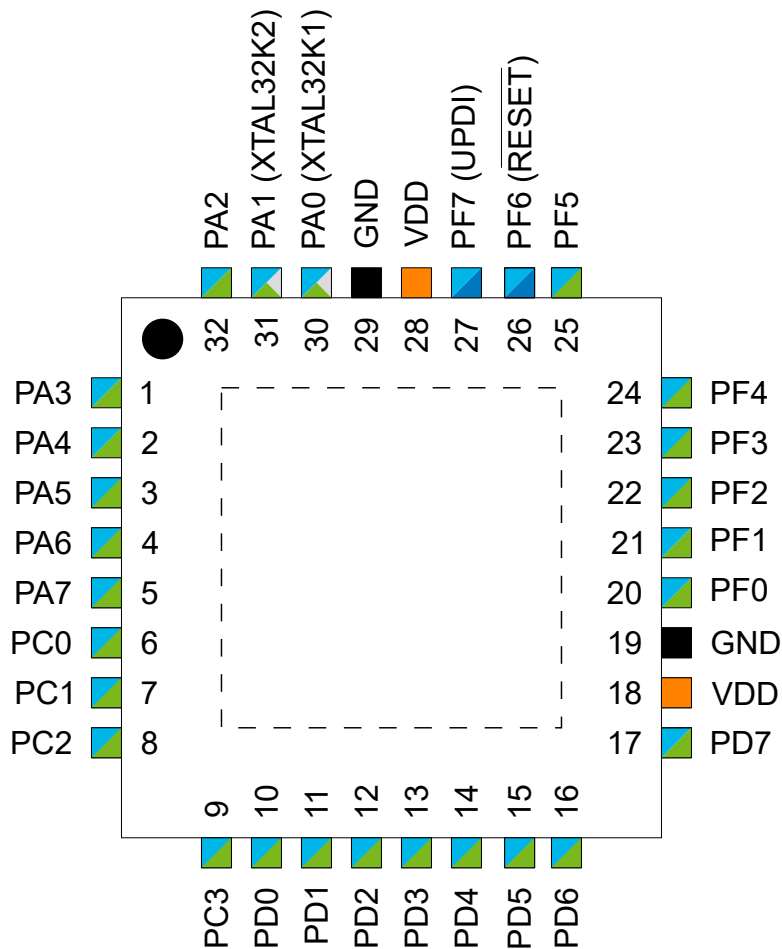



2.6 32-Pin VQFN and TQFP



Power

-  Power Supply
-  Ground
-  Pin on VDD Power Domain

Functionality

-  Programming/Debug
-  Clock/Crystal
-  Digital Function Only
-  Analog Function

3. I/O Multiplexing and Considerations

3.1 I/O Multiplexing

VQFN32 TQFP32	VQFN28	SPDIP28 SOIC28 SSOP28	VQFN20	SSOP20	SOIC14 SSOP14	Pin name ⁽¹⁾⁽²⁾	Special	ADC0	ACn	USART0	SPI0	TWI ⁽³⁾	TCE0-WEX0	TCBn	TCF0	EVSYS	CCL-LUTn
30	26	22	17	4	4	PA0	XTAL32K1 EXTCLK			TxD	MOSI ⁽⁴⁾	SDA(H) ⁽⁵⁾	W00 W00 ⁽⁶⁾		W00		0,IN0 0,IN0 ⁽⁷⁾
31	27	23	18	5	5	PA1	XTAL32K2			RxD	MISO ⁽⁴⁾	SCL(H) ⁽⁵⁾	W01 W01 ⁽⁶⁾		W01		0,IN1 0,IN1 ⁽⁷⁾
32	28	24	19	6	-	PA2	TWI Fm+	AIN22		XCK TxD ⁽⁸⁾		SDA(H)	W02 W00 ⁽⁶⁾	0,W0		EVOUTA	0,IN2 0,IN2 ⁽⁷⁾
1	1	25	20	7	-	PA3	TWI Fm+	AIN23		XDIR RxD ⁽⁸⁾		SCL(H)	W03 W01 ⁽⁶⁾	1,W0			0,OUT
2	2	26	1	8	-	PA4		AIN24		TxD ⁽⁸⁾	MOSI		W04 W02 ⁽⁶⁾				
3	3	27	2	9	-	PA5		AIN25		RxD ⁽⁸⁾	MISO		W05 W03 ⁽⁶⁾				
4	4	28	3	10	-	PA6		AIN26	1,AINP5	XCK ⁽⁸⁾	SCK		W06 W04 ⁽⁶⁾		W00 ⁽⁹⁾		0,OUT ⁽⁷⁾
5	5	1	4	11	-	PA7	CLKOUT	AIN27	0,OUT 1,AINP6 1,OUT	XDIR ⁽⁸⁾	SS ⁽⁴⁾		W07 W05 ⁽⁶⁾		W01 ⁽⁹⁾	EVOUTA ⁽⁷⁾	
6	6	2	5	12	6	PC0		AIN28			SCK ⁽⁴⁾ MOSI ⁽⁴⁾		W00 ⁽⁶⁾ W02 ⁽⁶⁾				1,IN0
7	7	3	6	13	7	PC1		AIN29		TxD ⁽⁸⁾	SS ⁽⁴⁾ MISO ⁽⁴⁾ MOSI ⁽⁴⁾		W01 ⁽⁶⁾ W03 ⁽⁶⁾				1,IN1
8	8	4	7	14	8	PC2	TWI Fm+	AIN30	0,AINN3 1,AINN3	RxD ⁽⁸⁾	SCK ⁽⁴⁾ MISO ⁽⁴⁾	SDA(C) SDA(H) ⁽⁵⁾ SDA(C) ⁽⁵⁾	W02 ⁽⁶⁾ W04 ⁽⁶⁾			EVOUTC	1,IN2
9	9	5	8	15	9	PC3	TWI Fm+	AIN31	0,AINP4 1,AINP4	XCK ⁽⁸⁾	SS ⁽⁴⁾ SCK ⁽⁴⁾	SCL(C) SCL(H) ⁽⁵⁾ SCL(C) ⁽⁵⁾	W03 ⁽⁶⁾ W05 ⁽⁶⁾				1,OUT
10	10	6	-	-	-	PD0		AIN0	0,AINN1 1,AINN1				W00 ⁽⁶⁾				2,IN0 2,IN0 ⁽⁷⁾
11	11	7	-	-	-	PD1		AIN1					W01 ⁽⁶⁾				2,IN1 2,IN1 ⁽⁷⁾
12	12	8	-	-	-	PD2		AIN2	0,AINP0 1,AINP0				W02 ⁽⁶⁾			EVOUTD	2,IN2 2,IN2 ⁽⁷⁾
13	13	9	-	-	-	PD3		AIN3	0,AINN0 1,AINP1				W03 ⁽⁶⁾				2,OUT
14	14	10	9	16	10	PD4		AIN4	0,AINP5 1,AINP2	TxD ⁽⁸⁾	MOSI ⁽⁴⁾		W04 ⁽⁶⁾				
15	15	11	10	17	11	PD5		AIN5	0,AINP6 1,AINN0	RxD ⁽⁸⁾	MISO ⁽⁴⁾		W05 ⁽⁶⁾				
16	16	12	11	18	12	PD6		AIN6	0,AINP3 1,AINP3	XCK ⁽⁸⁾	SCK ⁽⁴⁾		W06 ⁽⁶⁾				2,OUT ⁽⁷⁾
17	17	13	12	19	13	PD7	VREFA	AIN7	0,AINN2 1,AINN2	XDIR ⁽⁸⁾	SS ⁽⁴⁾		W07 ⁽⁶⁾			EVOUTD ⁽⁷⁾	
18	18	14	13	20	14	VDD											
19	19	15	14	1	1	GND											
20	20	16	-	-	-	PF0		AIN16					W00 ⁽⁶⁾				3,IN0

.....continued																					
VQFN32 TQFP32	VQFN28	SOPDIP28	SOIC28	SSOP28	VQFN20	SSOP20	SOIC14	SSOP14	Pin name ^{(1),(2)}	Special	ADC0	ACn	USART0	SPI0	TWI0 ⁽³⁾	TCE0+WE0	TCBn	TCF0	EVSYS	CCL+LUTn	
21	21	17	-	-	-	-	-	PF1			AIN17					WO1 ⁽⁴⁾					3,IN1
22	-	-	-	-	-	-	-	PF2			AIN18					WO2 ⁽⁴⁾			EVOUTF		3,IN2
23	-	-	-	-	-	-	-	PF3			AIN19					WO3 ⁽⁴⁾					3,OUT
24	-	-	-	-	-	-	-	PF4			AIN20					WO4 ⁽⁴⁾	0,WO ⁽⁴⁾	WO0 ⁽⁴⁾			
25	-	-	-	-	-	-	-	PF5			AIN21					WO5 ⁽⁴⁾	1,WO ⁽⁴⁾	WO1 ⁽⁴⁾			
26	22	18	15	2	2	2	2	PF6 ⁽⁵⁾	RESET				RxD ⁽⁶⁾								
27	23	19	16	3	3	3	3	PF7	UPDI				TxD ⁽⁶⁾	SS ⁽⁶⁾						EVOUTF ⁽⁷⁾	
28	24	20	-	-	-	-	-	VDD													
29	25	21	-	-	-	-	-	GND													

Notes:

1. The pin names are P_{xn} type, with *x* being the PORT instance (A, B, C, ...) and *n*, the pin number. The notation for signals is PORT_x_PIN_n. All pins can be used as event inputs.
2. All pins can be used for external interrupt.
3. Alternate pin positions. For selecting alternate positions, refer to the *PORTMUX - Port Multiplexer* section.
4. The TWI pins that can be used as hosts or clients are marked *H*. The pins with client-only are marked *C*.
5. Input-only.

4. Revision History

Doc. Rev.	Date	Comments
B	09/2023	Removed SOIC-20 package
A	11/2022	Initial document release

Microchip Information

The Microchip Website

Microchip provides online support via our website at www.microchip.com/. This website is used to make files and information easily available to customers. Some of the content available includes:

- **Product Support** – Data sheets and errata, application notes and sample programs, design resources, user’s guides and hardware support documents, latest software releases and archived software
- **General Technical Support** – Frequently Asked Questions (FAQs), technical support requests, online discussion groups, Microchip design partner program member listing
- **Business of Microchip** – Product selector and ordering guides, latest Microchip press releases, listing of seminars and events, listings of Microchip sales offices, distributors and factory representatives

Product Change Notification Service

Microchip’s product change notification service helps keep customers current on Microchip products. Subscribers will receive email notification whenever there are changes, updates, revisions or errata related to a specified product family or development tool of interest.

To register, go to www.microchip.com/pcn and follow the registration instructions.

Customer Support

Users of Microchip products can receive assistance through several channels:

- Distributor or Representative
- Local Sales Office
- Embedded Solutions Engineer (ESE)
- Technical Support

Customers should contact their distributor, representative or ESE for support. Local sales offices are also available to help customers. A listing of sales offices and locations is included in this document.

Technical support is available through the website at: www.microchip.com/support

Microchip Devices Code Protection Feature

Note the following details of the code protection feature on Microchip products:

- Microchip products meet the specifications contained in their particular Microchip Data Sheet.
- Microchip believes that its family of products is secure when used in the intended manner, within operating specifications, and under normal conditions.
- Microchip values and aggressively protects its intellectual property rights. Attempts to breach the code protection features of Microchip product is strictly prohibited and may violate the Digital Millennium Copyright Act.
- Neither Microchip nor any other semiconductor manufacturer can guarantee the security of its code. Code protection does not mean that we are guaranteeing the product is “unbreakable”. Code protection is constantly evolving. Microchip is committed to continuously improving the code protection features of our products.

Legal Notice

This publication and the information herein may be used only with Microchip products, including to design, test, and integrate Microchip products with your application. Use of this information in any other manner violates these terms. Information regarding device applications is provided only for your convenience and may be superseded by updates. It is your responsibility to ensure

that your application meets with your specifications. Contact your local Microchip sales office for additional support or, obtain additional support at www.microchip.com/en-us/support/design-help/client-support-services.

THIS INFORMATION IS PROVIDED BY MICROCHIP "AS IS". MICROCHIP MAKES NO REPRESENTATIONS OR WARRANTIES OF ANY KIND WHETHER EXPRESS OR IMPLIED, WRITTEN OR ORAL, STATUTORY OR OTHERWISE, RELATED TO THE INFORMATION INCLUDING BUT NOT LIMITED TO ANY IMPLIED WARRANTIES OF NON-INFRINGEMENT, MERCHANTABILITY, AND FITNESS FOR A PARTICULAR PURPOSE, OR WARRANTIES RELATED TO ITS CONDITION, QUALITY, OR PERFORMANCE.

IN NO EVENT WILL MICROCHIP BE LIABLE FOR ANY INDIRECT, SPECIAL, PUNITIVE, INCIDENTAL, OR CONSEQUENTIAL LOSS, DAMAGE, COST, OR EXPENSE OF ANY KIND WHATSOEVER RELATED TO THE INFORMATION OR ITS USE, HOWEVER CAUSED, EVEN IF MICROCHIP HAS BEEN ADVISED OF THE POSSIBILITY OR THE DAMAGES ARE FORESEEABLE. TO THE FULLEST EXTENT ALLOWED BY LAW, MICROCHIP'S TOTAL LIABILITY ON ALL CLAIMS IN ANY WAY RELATED TO THE INFORMATION OR ITS USE WILL NOT EXCEED THE AMOUNT OF FEES, IF ANY, THAT YOU HAVE PAID DIRECTLY TO MICROCHIP FOR THE INFORMATION.

Use of Microchip devices in life support and/or safety applications is entirely at the buyer's risk, and the buyer agrees to defend, indemnify and hold harmless Microchip from any and all damages, claims, suits, or expenses resulting from such use. No licenses are conveyed, implicitly or otherwise, under any Microchip intellectual property rights unless otherwise stated.

Trademarks

The Microchip name and logo, the Microchip logo, Adaptec, AVR, AVR logo, AVR Freaks, BesTime, BitCloud, CryptoMemory, CryptoRF, dsPIC, flexPWR, HELDO, IGLOO, JukeBlox, KeeLoq, Kleer, LANCheck, LinkMD, maXStylus, maXTouch, MediaLB, megaAVR, Microsemi, Microsemi logo, MOST, MOST logo, MPLAB, OptoLyzer, PIC, picoPower, PICSTART, PIC32 logo, PolarFire, Prochip Designer, QTouch, SAM-BA, SenGenuity, SpyNIC, SST, SST Logo, SuperFlash, Symmetricom, SyncServer, Tachyon, TimeSource, tinyAVR, UNI/O, Vectron, and XMEGA are registered trademarks of Microchip Technology Incorporated in the U.S.A. and other countries.

AgileSwitch, ClockWorks, The Embedded Control Solutions Company, EtherSynch, Flashtec, Hyper Speed Control, HyperLight Load, Libero, motorBench, mTouch, Powermite 3, Precision Edge, ProASIC, ProASIC Plus, ProASIC Plus logo, Quiet-Wire, SmartFusion, SyncWorld, TimeCesium, TimeHub, TimePictra, TimeProvider, and ZL are registered trademarks of Microchip Technology Incorporated in the U.S.A.

Adjacent Key Suppression, AKS, Analog-for-the-Digital Age, Any Capacitor, AnyIn, AnyOut, Augmented Switching, BlueSky, BodyCom, Clockstudio, CodeGuard, CryptoAuthentication, CryptoAutomotive, CryptoCompanion, CryptoController, dsPICDEM, dsPICDEM.net, Dynamic Average Matching, DAM, ECAN, Espresso T1S, EtherGREEN, EyeOpen, GridTime, IdealBridge, IGaT, In-Circuit Serial Programming, ICSP, INICnet, Intelligent Paralleling, IntelliMOS, Inter-Chip Connectivity, JitterBlocker, Knob-on-Display, MarginLink, maxCrypto, maxView, memBrain, Mindi, MiWi, MPASM, MPF, MPLAB Certified logo, MPLIB, MPLINK, mSiC, MultiTRAK, NetDetach, Omniscient Code Generation, PICDEM, PICDEM.net, PICkit, PICtail, Power MOS IV, Power MOS 7, PowerSmart, PureSilicon, QMatrix, REAL ICE, Ripple Blocker, RTAX, RTG4, SAM-ICE, Serial Quad I/O, simpleMAP, SimpliPHY, SmartBuffer, SmartHLS, SMART-I.S., storClad, SQI, SuperSwitcher, SuperSwitcher II, Switchtec, SynchroPHY, Total Endurance, Trusted Time, TSHARC, Turing, USBCheck, VariSense, VectorBlox, VeriPHY, ViewSpan, WiperLock, XpressConnect, and ZENA are trademarks of Microchip Technology Incorporated in the U.S.A. and other countries.

SQTP is a service mark of Microchip Technology Incorporated in the U.S.A.

The Adaptec logo, Frequency on Demand, Silicon Storage Technology, and Symmcom are registered trademarks of Microchip Technology Inc. in other countries.

GestIC is a registered trademark of Microchip Technology Germany II GmbH & Co. KG, a subsidiary of Microchip Technology Inc., in other countries.

All other trademarks mentioned herein are property of their respective companies.

© 2023, Microchip Technology Incorporated and its subsidiaries. All Rights Reserved.

ISBN: 978-1-6683-3058-6

Quality Management System

For information regarding Microchip's Quality Management Systems, please visit www.microchip.com/quality.

Worldwide Sales and Service

AMERICAS	ASIA/PACIFIC	ASIA/PACIFIC	EUROPE
<p>Corporate Office 2355 West Chandler Blvd. Chandler, AZ 85224-6199 Tel: 480-792-7200 Fax: 480-792-7277 Technical Support: www.microchip.com/support Web Address: www.microchip.com</p> <p>Atlanta Duluth, GA Tel: 678-957-9614 Fax: 678-957-1455</p> <p>Austin, TX Tel: 512-257-3370</p> <p>Boston Westborough, MA Tel: 774-760-0087 Fax: 774-760-0088</p> <p>Chicago Itasca, IL Tel: 630-285-0071 Fax: 630-285-0075</p> <p>Dallas Addison, TX Tel: 972-818-7423 Fax: 972-818-2924</p> <p>Detroit Novi, MI Tel: 248-848-4000</p> <p>Houston, TX Tel: 281-894-5983</p> <p>Indianapolis Noblesville, IN Tel: 317-773-8323 Fax: 317-773-5453 Tel: 317-536-2380</p> <p>Los Angeles Mission Viejo, CA Tel: 949-462-9523 Fax: 949-462-9608 Tel: 951-273-7800</p> <p>Raleigh, NC Tel: 919-844-7510</p> <p>New York, NY Tel: 631-435-6000</p> <p>San Jose, CA Tel: 408-735-9110 Tel: 408-436-4270</p> <p>Canada - Toronto Tel: 905-695-1980 Fax: 905-695-2078</p>	<p>Australia - Sydney Tel: 61-2-9868-6733</p> <p>China - Beijing Tel: 86-10-8569-7000</p> <p>China - Chengdu Tel: 86-28-8665-5511</p> <p>China - Chongqing Tel: 86-23-8980-9588</p> <p>China - Dongguan Tel: 86-769-8702-9880</p> <p>China - Guangzhou Tel: 86-20-8755-8029</p> <p>China - Hangzhou Tel: 86-571-8792-8115</p> <p>China - Hong Kong SAR Tel: 852-2943-5100</p> <p>China - Nanjing Tel: 86-25-8473-2460</p> <p>China - Qingdao Tel: 86-532-8502-7355</p> <p>China - Shanghai Tel: 86-21-3326-8000</p> <p>China - Shenyang Tel: 86-24-2334-2829</p> <p>China - Shenzhen Tel: 86-755-8864-2200</p> <p>China - Suzhou Tel: 86-186-6233-1526</p> <p>China - Wuhan Tel: 86-27-5980-5300</p> <p>China - Xian Tel: 86-29-8833-7252</p> <p>China - Xiamen Tel: 86-592-2388138</p> <p>China - Zhuhai Tel: 86-756-3210040</p>	<p>India - Bangalore Tel: 91-80-3090-4444</p> <p>India - New Delhi Tel: 91-11-4160-8631</p> <p>India - Pune Tel: 91-20-4121-0141</p> <p>Japan - Osaka Tel: 81-6-6152-7160</p> <p>Japan - Tokyo Tel: 81-3-6880-3770</p> <p>Korea - Daegu Tel: 82-53-744-4301</p> <p>Korea - Seoul Tel: 82-2-554-7200</p> <p>Malaysia - Kuala Lumpur Tel: 60-3-7651-7906</p> <p>Malaysia - Penang Tel: 60-4-227-8870</p> <p>Philippines - Manila Tel: 63-2-634-9065</p> <p>Singapore Tel: 65-6334-8870</p> <p>Taiwan - Hsin Chu Tel: 886-3-577-8366</p> <p>Taiwan - Kaohsiung Tel: 886-7-213-7830</p> <p>Taiwan - Taipei Tel: 886-2-2508-8600</p> <p>Thailand - Bangkok Tel: 66-2-694-1351</p> <p>Vietnam - Ho Chi Minh Tel: 84-28-5448-2100</p>	<p>Austria - Wels Tel: 43-7242-2244-39 Fax: 43-7242-2244-393</p> <p>Denmark - Copenhagen Tel: 45-4485-5910 Fax: 45-4485-2829</p> <p>Finland - Espoo Tel: 358-9-4520-820</p> <p>France - Paris Tel: 33-1-69-53-63-20 Fax: 33-1-69-30-90-79</p> <p>Germany - Garching Tel: 49-8931-9700</p> <p>Germany - Haan Tel: 49-2129-3766400</p> <p>Germany - Heilbronn Tel: 49-7131-72400</p> <p>Germany - Karlsruhe Tel: 49-721-625370</p> <p>Germany - Munich Tel: 49-89-627-144-0 Fax: 49-89-627-144-44</p> <p>Germany - Rosenheim Tel: 49-8031-354-560</p> <p>Israel - Ra'anana Tel: 972-9-744-7705</p> <p>Italy - Milan Tel: 39-0331-742611 Fax: 39-0331-466781</p> <p>Italy - Padova Tel: 39-049-7625286</p> <p>Netherlands - Drunen Tel: 31-416-690399 Fax: 31-416-690340</p> <p>Norway - Trondheim Tel: 47-72884388</p> <p>Poland - Warsaw Tel: 48-22-3325737</p> <p>Romania - Bucharest Tel: 40-21-407-87-50</p> <p>Spain - Madrid Tel: 34-91-708-08-90 Fax: 34-91-708-08-91</p> <p>Sweden - Gothenberg Tel: 46-31-704-60-40</p> <p>Sweden - Stockholm Tel: 46-8-5090-4654</p> <p>UK - Wokingham Tel: 44-118-921-5800 Fax: 44-118-921-5820</p>