

LVPECL, LVDS, and HCSL Crystal Oscillator

Features

- 40 fs_{RMS} Phase Jitter Typical, 12 kHz to 20 MHz
- 3rd OT or Fundamental Crystal Design
- Extended Operating Temperature Range: -55°C to +125°C
- 100 MHz to 312.5 MHz Output Frequencies
- Excellent Power Supply Rejection Ratio
- Glitch Free Output upon Power-Up and Enable
- Hermetically Sealed 7 mm x 5 mm Ceramic Package
- Product is Compliant to RoHS Directive and Fully Compatible with Lead-Free Assembly (Excluding Solder Dipped, _SNPB, Option)

Applications

- Medical, Ultrasound
- Ethernet, GbE, SynchE
- Fibre Channel
- PON
- Clock Source for A/Ds, D/As, FPGAs
- Test and Measurement
- Storage Area Network

General Description

Microchip's VC-714 crystal oscillator is a quartz-stabilized, low phase jitter, differential output oscillator that is hermetically sealed in a 7 mm x 5 mm ceramic package.

Block Diagram

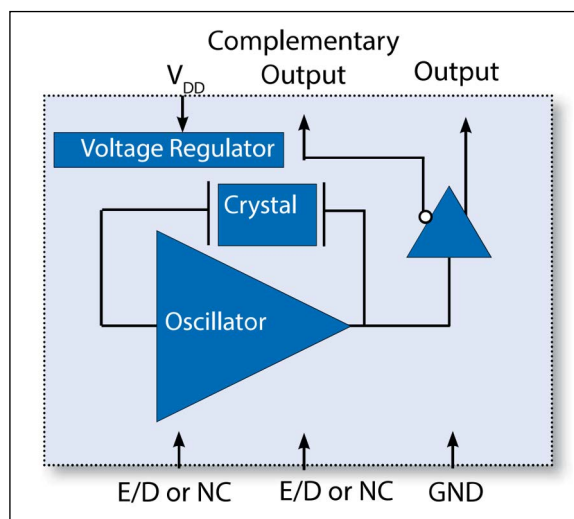

Phase Noise Plot

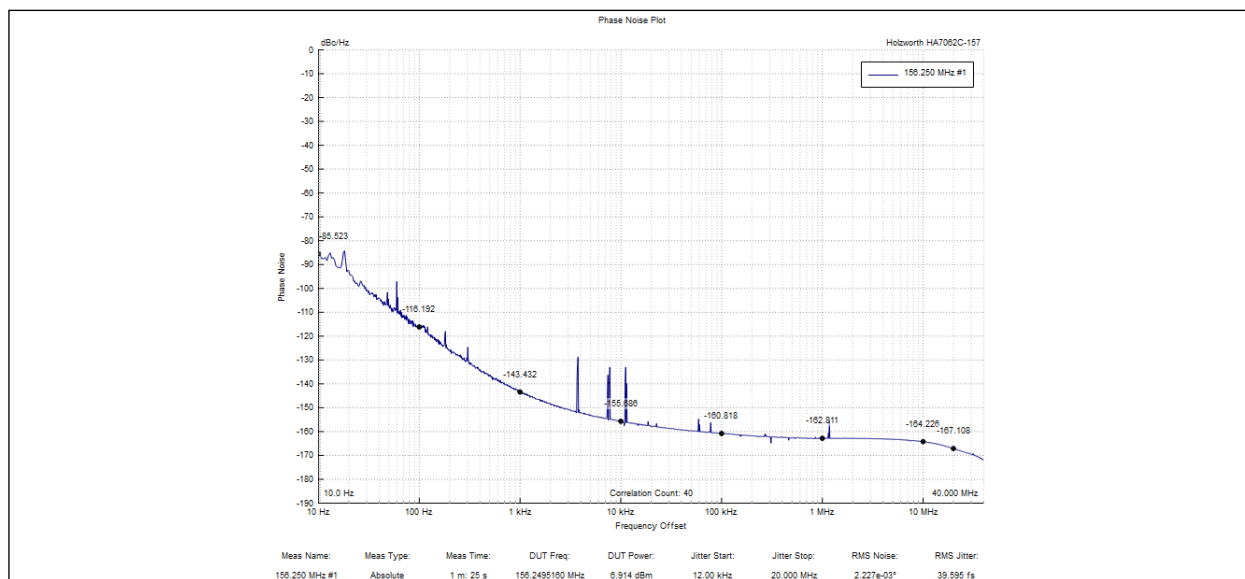

FIGURE 0-1: RMS Jitter, 40 fs_{RMS} at 156.25 MHz, over 12 kHz to 20 MHz.

VC-714

1.0 ELECTRICAL CHARACTERISTICS

Absolute Maximum Ratings †

Supply Voltage	-0.3V to +4.5V
Enable Disable Voltage	-0.3V to $V_{DD} + 0.3V$
ESD Rating, Human Body Model (Note 1)	2 kV
ESD Rating, Charged Device Model (Note 1)	200V
Storage Temperature (T_S)	-55°C to +125°C
Junction Temperature (T_J)	+150°C

† **Notice:** Stresses in excess of the Absolute Maximum Ratings can permanently damage the device. Functional operation is not implied at these or any other conditions in excess of conditions represented in the operational sections of this data sheet. Exposure to Absolute Maximum Ratings for extended periods may adversely affect device reliability.

Note 1: Although ESD protection circuitry has been designed into the VC-714, proper precautions should be taken when handling and mounting. Microchip employs a Human Body Model (HBM) and a Charged Device Model (CDM) for ESD susceptibility testing and design protection evaluation. ESD thresholds are dependent on the circuit parameters used to define the model. Although no industry standard has been adopted for the CDM, a standard resistance of 1.5 kΩ and capacitance of 100 pF is widely used and therefore can be used for comparison purposes.

ELECTRICAL CHARACTERISTICS, LVPECL OPTION

Parameter	Sym.	Min.	Typ.	Max.	Units	Conditions
Supply Voltage (Note 1)	V_{DD}	2.375	2.5	2.625	V	Ordering Option
		3.135	3.3	3.465		
Current Consumption	I_{DD}	—	—	70	mA	—
Frequency						
Nominal Frequency	f_N	100	—	320	MHz	Ordering Option
Stability (Note 2)	—	—	—	±20	ppm	Ordering Option
		—	—	±25		
		—	—	±50		
		—	—	±100		
Outputs						
Output Logic Level High (Note 3)	V_{OH}	$V_{DD} - 1.085$	—	$V_{DD} - 0.860$	V	$V_{DD} = +2.5V$
Output Logic Level Low (Note 3)	V_{OL}	$V_{DD} - 1.810$	—	$V_{DD} - 1.620$		

- Note 1:** The VC-714 power supply should be filtered. For example, a 10 μF, 0.1 μF, and 0.01 μF capacitor.
- 2:** Includes calibration tolerance, operating temperature, supply voltage variations, aging, and IR reflow.
- 3:** Figure 1-1 defines the test circuit and Figure 1-2 defines these parameters.
- 4:** Output rise and fall time will be 600 ps maximum for -40°C to +105°C and -40°C to +125°C temperature ranges.
- 5:** Duty Cycle is measured as On/Time Period.
- 6:** Measured using an Agilent E5052 Signal Source Analyzer at 25°C.
- 7:** Outputs will be enabled if Enable/Disable is left open. There is an oscillation detection circuit that ensures glitch free output upon power-up or enable.
- 8:** In order to reduce current, the pull-up resistance is higher when V_{DD} is set to ground.

ELECTRICAL CHARACTERISTICS, LVPECL OPTION (CONTINUED)

Parameter	Sym.	Min.	Typ.	Max.	Units	Conditions
Output Logic Level High (Note 3)	V_{OH}	$V_{DD} - 1.085$	—	$V_{DD} - 0.880$	V	$V_{DD} = +3.3V$
Output Logic Level Low (Note 3)	V_{OL}	$V_{DD} - 1.810$	—	$V_{DD} - 1.620$		
Output Rise and Fall Time (Note 3, Note 4)	t_r/t_f	—	—	400	ps	—
Load	—	50Ω into $V_{DD} - 2.0V$			—	—
Duty Cycle (Note 5)	DC	45	—	55	%	—
Phase Noise, 3.3V, 156.25 MHz (Note 6)	ϕ_N	—	–85	—	dBc/Hz	10 Hz
		—	–116	—		100 Hz
		—	–143	—		1 kHz
		—	–141	—		10 kHz
		—	–156	—		100 kHz
		—	–163	—		1 MHz
		—	–163	—		10 MHz
		—	–167	—		20 MHz
Phase Jitter, 156.25 MHz, 12 kHz to 20 MHz (Note 6)	ϕ_J	—	40	60	fs	—
Enable/Disable						
Outputs Enabled (Note 7)	V_{IH}	$0.7 * V_{DD}$	—	—	V	—
Outputs Disabled	V_{IL}	—	—	$0.3 * V_{DD}$	V	—
Disable Time	t_D	—	—	200	ns	—
E/D Pull-Up Resistance (Note 8)	—	0.5	—	2	MΩ	E/D = GND
E/D Pull-Up Resistance	—	30	—	150	kΩ	E/D = V_{DD}
Start-Up Time	t_{SU}	—	—	10	ms	—
Operating Temperature	T_{OP}	–10	—	70	°C	Ordering Option
		–40	—	85		
		–40	—	105		
		–40	—	125		
		–55	—	125		

- Note 1:** The VC-714 power supply should be filtered. For example, a 10 μF, 0.1 μF, and 0.01 μF capacitor.
- 2:** Includes calibration tolerance, operating temperature, supply voltage variations, aging, and IR reflow.
- 3:** Figure 1-1 defines the test circuit and Figure 1-2 defines these parameters.
- 4:** Output rise and fall time will be 600 ps maximum for –40°C to +105°C and –40°C to +125°C temperature ranges.
- 5:** Duty Cycle is measured as On/Time Period.
- 6:** Measured using an Agilent E5052 Signal Source Analyzer at 25°C.
- 7:** Outputs will be enabled if Enable/Disable is left open. There is an oscillation detection circuit that ensures glitch free output upon power-up or enable.
- 8:** In order to reduce current, the pull-up resistance is higher when V_{DD} is set to ground.

VC-714

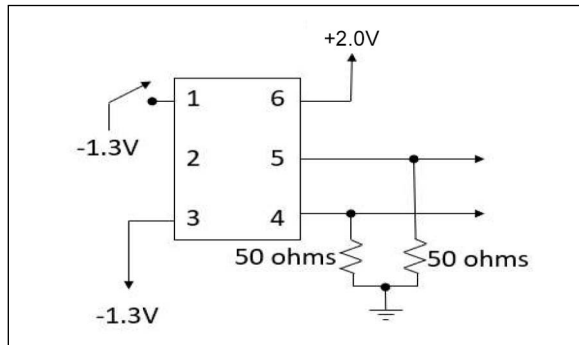

FIGURE 1-1: Test Circuit.

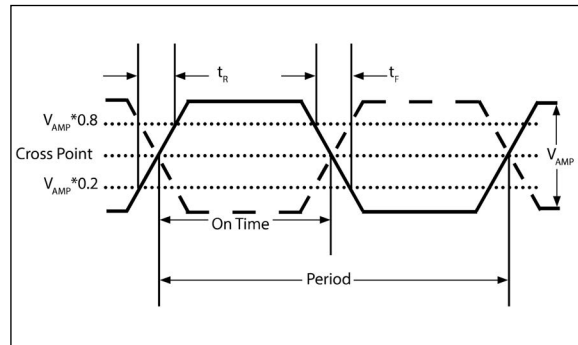

FIGURE 1-2: Output Rise/Fall Time.

Note: Pin 3, and Pin 1 when checking E/D, are $-0.5V$ when testing for $V_{DD} = 2.5V$.

ELECTRICAL CHARACTERISTICS, LVDS OPTION

Parameter	Sym.	Min.	Typ.	Max.	Units	Conditions
Supply Voltage (Note 1)	V_{DD}	1.71	1.80	1.89	V	Ordering Option
		2.375	2.5	2.625		
		3.135	3.3	3.465		
Current Consumption	I_{DD}	—	—	25	mA	1.8V
		—	—	35		2.5V
		—	—	35		3.3V
Frequency						
Nominal Frequency	f_N	100	—	320	MHz	Ordering Option
Stability (Note 2)	—	—	—	± 20	ppm	Ordering Option
		—	—	± 25		
		—	—	± 50		
		—	—	± 100		
Outputs						
Output Logic Level High (Note 3)	V_{OH}	—	1.43	1.6	V	—
Output Logic Level Low (Note 3)	V_{OL}	0.9	1.10	—		
Output Amplitude	—	247	350	454	mV	—
Differential Output Error	—	—	—	50	mV	—
Offset Voltage	—	1.125	1.25	1.375	V	—
Offset Voltage Error	—	—	—	50	mV	—
Output Leakage Current, Outputs Disabled	—	—	—	30	μA	—

Note 1: The VC-714 power supply should be filtered. For example, a 10 μF , 0.1 μF , and 0.01 μF capacitor.

Note 2: Includes calibration tolerance, operating temperature, supply voltage variations, aging, and IR reflow.

Note 3: Figure 1-3 defines the test circuit and Figure 1-2 defines these parameters.

Note 4: Duty Cycle is measured as On/Time Period.

Note 5: Measured using an Agilent E5052 Signal Source Analyzer at 25°C.

Note 6: Outputs will be enabled if Enable/Disable is left open. There is an oscillation detection circuit that ensures glitch free output upon power-up or enable.

Note 7: In order to reduce current, the pull-up resistance is higher when V_{DD} is set to ground.

ELECTRICAL CHARACTERISTICS, LVDS OPTION (CONTINUED)

Parameter	Sym.	Min.	Typ.	Max.	Units	Conditions
Output Rise and Fall Time (Note 3)	t_r/t_f	—	—	300	ps	3.3V, 2.5V
		—	—	400	ps	1.8V
Load	—	100Ω Differential			—	—
Duty Cycle (Note 4)	DC	45	—	55	%	—
Phase Noise, 3.3V, 156.25 MHz (Note 5)	ϕ_N	—	-85	—	dBc/Hz	10 Hz
		—	-116	—		100 Hz
		—	-143	—		1 kHz
		—	-156	—		10 kHz
		—	-160	—		100 kHz
		—	-162	—		1 MHz
		—	-164	—		10 MHz
		—	-167	—		20 MHz
Phase Jitter, 156.25 MHz, 12 kHz to 20 MHz (Note 5)	ϕ_J	—	40	60	fs	—
Enable/Disable						
Outputs Enabled (Note 6)	V_{IH}	$0.7 * V_{DD}$	—	—	V	—
Outputs Disabled	V_{IL}	—	—	$0.3 * V_{DD}$	V	—
Disable Time	t_D	—	—	200	ns	—
E/D Pull-Up Resistance (Note 7)	—	0.5	—	2	MΩ	E/D = GND
E/D Pull-Up Resistance	—	30	—	150	kΩ	E/D = V_{DD}
Start-Up Time	t_{SU}	—	—	10	ms	—
Operating Temperature	T_{OP}	-10	—	70	°C	Ordering Option
		-40	—	85		
		-40	—	105		
		-40	—	125		
		-55	—	125		

- Note 1:** The VC-714 power supply should be filtered. For example, a 10 μF, 0.1 μF, and 0.01 μF capacitor.
- 2:** Includes calibration tolerance, operating temperature, supply voltage variations, aging, and IR reflow.
- 3:** Figure 1-3 defines the test circuit and Figure 1-2 defines these parameters.
- 4:** Duty Cycle is measured as On/Time Period.
- 5:** Measured using an Agilent E5052 Signal Source Analyzer at 25°C.
- 6:** Outputs will be enabled if Enable/Disable is left open. There is an oscillation detection circuit that ensures glitch free output upon power-up or enable.
- 7:** In order to reduce current, the pull-up resistance is higher when V_{DD} is set to ground.

VC-714

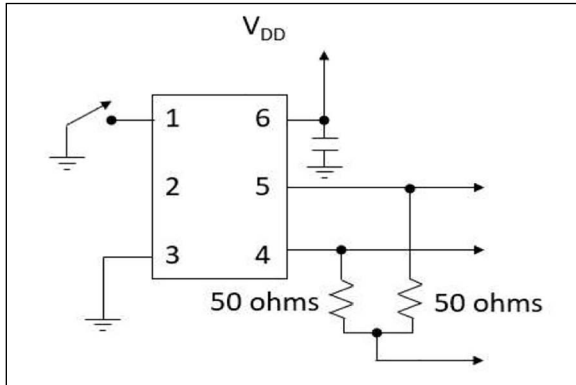

FIGURE 1-3: LVDS Test Circuit.

ELECTRICAL CHARACTERISTICS, HCSL OPTION

Parameter	Symbol	Min.	Typ.	Max.	Units	Conditions
Supply Voltage (Note 1)	V_{DD}	1.71	1.8	1.89	V	Ordering Option
		2.375	2.5	2.625		
		3.135	3.3	3.465		
Current Consumption	I_{DD}	—	—	46	mA	1.8V, 2.5V, 3.3V
Frequency						
Nominal Frequency	f_N	100	—	200	MHz	Ordering Option
Stability (Note 2)	—	—	—	± 20	ppm	Ordering Option
		—	—	± 25		
		—	—	± 30		
		—	—	± 50		
		—	—	± 100		
Outputs						
Output Logic Level High (Note 3)	V_{OH}	0.6	—	0.9	V	3.3V, 2.5V
		0.5	—	1.0	V	1.8V
Output Logic Level Low (Note 3)	V_{OL}	-0.15	—	0.15	V	1.8V, 2.5V, 3.3V
Output Leakage Current, Outputs Disabled	—	—	—	30	μA	—
Output Rise and Fall Time (Note 3)	t_r/t_f	—	—	600	ps	—
Load	—	50 Ω to GND			—	—
Duty Cycle (Note 4)	DC	45	—	55	%	—
Phase Noise, 3.3V, 156.25 MHz (Note 5)	ϕ_N	—	-79	—	dBc/Hz	10 Hz
		—	-110	—		100 Hz
		—	-130	—		1 kHz
		—	-154	—		10 kHz
		—	-160	—		100 kHz
		—	-162	—		1 MHz
		—	-163	—		10 MHz
		—	-164	—		20 MHz
Phase Jitter, 100.000 MHz, 12 kHz to 20 MHz (Note 5)	ϕ_J	—	55	—	fs	—
Enable/Disable						
Outputs Enabled (Note 6)	V_{IH}	$0.7 * V_{DD}$	—	—	V	—

ELECTRICAL CHARACTERISTICS, HCSL OPTION (CONTINUED)

Parameter	Symbol	Min.	Typ.	Max.	Units	Conditions
Outputs Disabled	V_{IL}	—	—	$0.3 * V_{DD}$	V	—
Disable Time	t_D	—	—	200	ns	—
E/D Pull-Up Resistance (Note 7)	—	0.5	—	2	M Ω	E/D = GND
E/D Pull-Up Resistance	—	30	—	150	k Ω	E/D = V_{DD}
Start-Up Time	t_{SU}	—	—	10	ms	—
Operating Temperature	T_{OP}	-10	—	70	°C	Ordering Option
		-40	—	85		
		-40	—	105		

- Note 1:** The VC-714 power supply should be filtered. For example, a 10 μ F, 0.1 μ F, and 0.01 μ F capacitor.
- 2:** Includes calibration tolerance, operating temperature, supply voltage variations, aging, and IR reflow.
- 3:** Figure 1-4 defines the test circuit and Figure 1-2 defines these parameters.
- 4:** Duty Cycle is measured as On/Time Period.
- 5:** Measured using an Agilent E5052 Signal Source Analyzer at 25°C.
- 6:** Outputs will be enabled if Enable/Disable is left open. There is an oscillation detection circuit that ensures glitch free output upon power-up or enable.
- 7:** In order to reduce current, the pull-up resistance is higher when V_{DD} is set to ground.

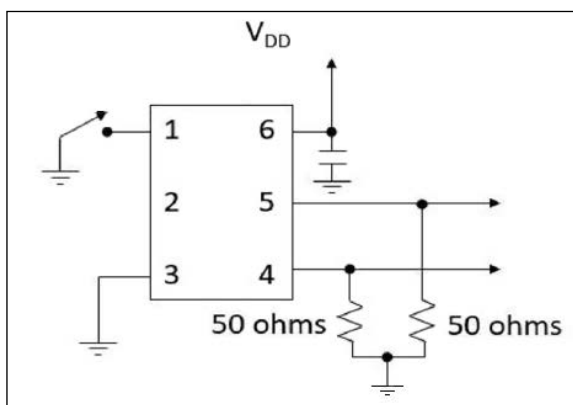

FIGURE 1-4: HCSL Test Circuit.

2.0 PIN DESCRIPTIONS

The descriptions of the pins are listed in [Table 2-1](#).

TABLE 2-1: PIN FUNCTION TABLE

Pin Number	Pin Name	Description
1	E/D or NC	Enable/Disable or No Connection.
2	E/D or NC	Enable/Disable or No Connection.
3	GND	Electrical and lid ground.
4	f_O	Output frequency.
5	Cf_O	Complementary output frequency.
6	V_{DD}	Supply voltage.

TABLE 2-2: ENABLE/DISABLE FUNCTION

E/D Pin	Output
High	Clock Output
Open	Clock Output
Low	High Impedance

3.0 APPLICATION DIAGRAMS

3.1 LVPECL Application Diagrams

The VC-714 incorporates a standard PECL output scheme, which are unterminated FET drains. There are numerous application notes on terminating and interfacing PECL logic and the two most common methods are a single resistor to ground (Figure 3-1) and a pull-up/pull-down scheme as shown in Figure 3-2. AC-coupling capacitors are optional, depending on the application and the input logic requirements of the next stage.

One of the most important considerations is terminating the Output and Complementary Outputs equally. An unused output should not be left unterminated because if one of the two outputs is left open, it will result in excessive jitter on both. PCB layout must take this and 50Ω impedance matching into account. Load matching and power supply noise are the main contributors to jitter related problems.

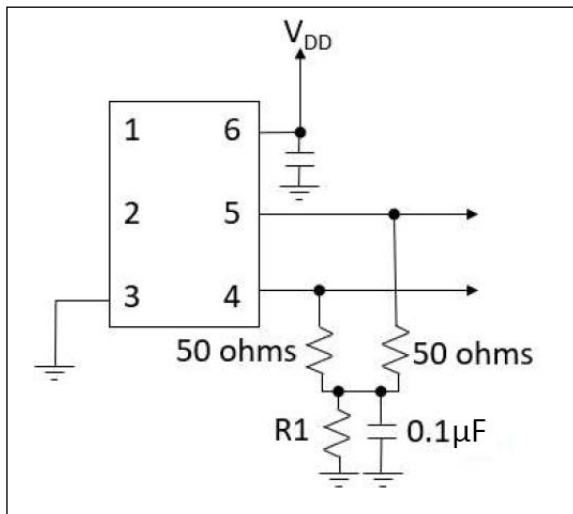

FIGURE 3-1: Pull-Down Resistor Termination Scheme.

Figure 3-1 shows one option to terminate LVPECL outputs and is optimized to reduce common mode noise. R1 is 50Ω for 3.3V supply voltage and 18Ω for 2.5V.

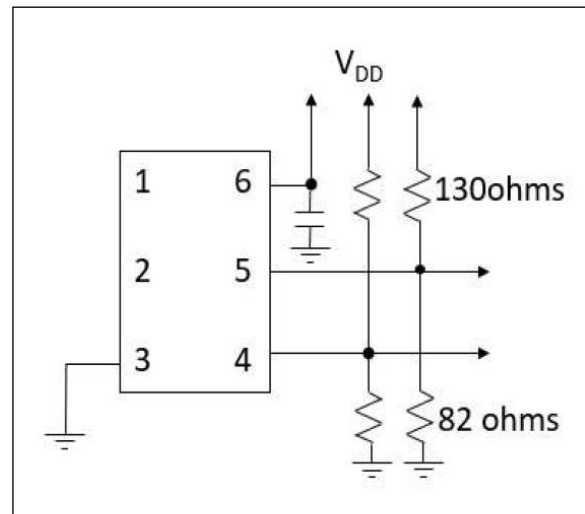

FIGURE 3-2: Pull-Up/Pull-Down Termination.

Resistor values shown are typical for 3.3V operation. For 2.5V operation, the resistor to ground is 62Ω and the resistor to supply is 250Ω. AC blocking capacitors can be used if the DC levels are incompatible.

3.2 LVDS Application Diagrams

One of the most important considerations is terminating the Output and Complementary Outputs equally. An unused output should not be left unterminated because if one of the two outputs is left open, it will result in excessive jitter on both. PCB layout must take this and 50Ω impedance matching into account. Load matching and power supply noise are the main contributors to jitter related problems.

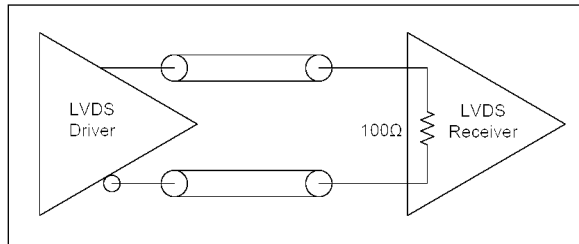

FIGURE 3-3: LVDS-to-LVDS Connection, Internal 100Ω Resistor.

Some LVDS structures have an internal 100Ω resistor on the input and do not need additional components. AC blocking capacitors can be used if the DC levels are incompatible.

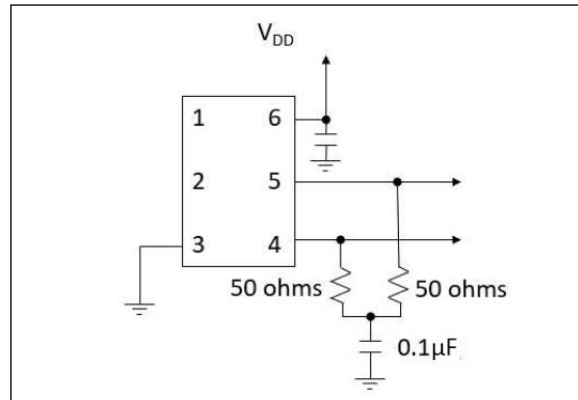

FIGURE 3-4: LVDS-to-LVDS Connection.

Some input structures may not have an internal 100Ω resistor on the input and will need an external 100Ω resistor for impedance matching. Also, the input may have an internal DC bias that may not be compatible with LVDS levels. AC blocking capacitors can be used.

4.0 RELIABILITY

Microchip qualification will include aging at various extreme temperatures, shock and vibration, temperature cycling, and IR reflow simulation. The VC-714 family is capable of meeting the following qualification tests.

TABLE 4-1: ENVIRONMENTAL COMPLIANCE

Parameter	Conditions
Mechanical Shock	MIL-STD-883, Method 2002
Mechanical Vibration	MIL-STD-883, Method 2007
Temperature Cycle	MIL-STD-883, Method 1010
Solderability	MIL-STD-883, Method 2003
Gross and Fine Leak	MIL-STD-883, Method 1014
Resistance to Solvents	MIL-STD-883, Method 2015
Moisture Sensitivity Level	MSL 1
Contact Pads	Gold (0.3 μm min., 1.0 μm max.) over Nickel
Contact Pads, _SNPB option	Tinned using solder alloy Sn63Pb37 in accordance with J-STD-006
θ_{JC} (Bottom of Case)	30°C/W
Maximum Junction Temperature	150°C
Weight	180 mg

5.0 IR REFLOW

Devices are built using lead-free epoxy and can be subjected to standard lead-free IR reflow conditions shown in Table 5-1. Contact pads are gold over nickel and lower maximum temperatures can also be used, such as 220°C.

NOTE: Devices which have been solder dipped, _SNPB option, will not be Pb-Free.

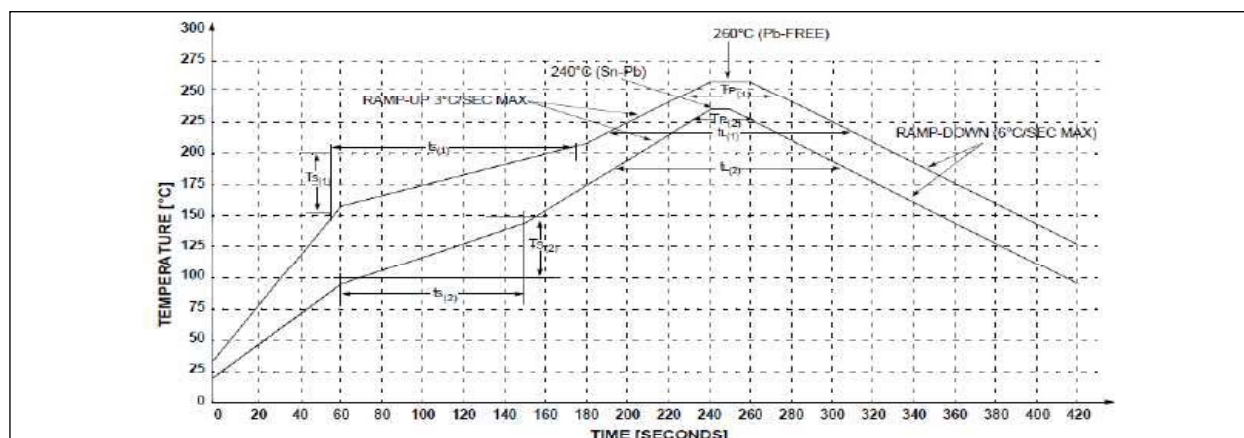

FIGURE 5-1: Solder Profile.

TABLE 5-1: REFLOW PROFILE

Symbol	Minimum	Maximum	Conditions
T _{S(1)}	150°C	200°C	Pb-Free
T _{S(2)}	100°C	150°C	_SNPB Option
t _{S(1)}	60 sec.	180 sec.	Pb-Free
t _{S(2)}	60 sec.	120 sec.	_SNPB Option
t _{I(1)}	60 sec.	150 sec.	Pb-Free
t _{I(2)}	60 sec.	150 sec.	_SNPB Option
T _{P(1)}	245°C	260°C	Pb-Free
T _{P(2)}	225°C	240°C	_SNPB Option

VC-714

6.0 TAPE AND REEL

TABLE 6-1: TAPE AND REEL DIMENSIONS

Tape Dimensions (mm)						Reel Dimensions (mm)							
Dimension	W	F	Do	Po	P1	A	B	C	D	N	W1	W2	# per Reel
Tolerance	Typ	Typ	Typ	Typ	Typ	Typ	Typ	Typ	Typ	Typ	Typ	Max	
VC-714	16	7.5	1.5	4	8	180	2	13	21	55	17	21	1000

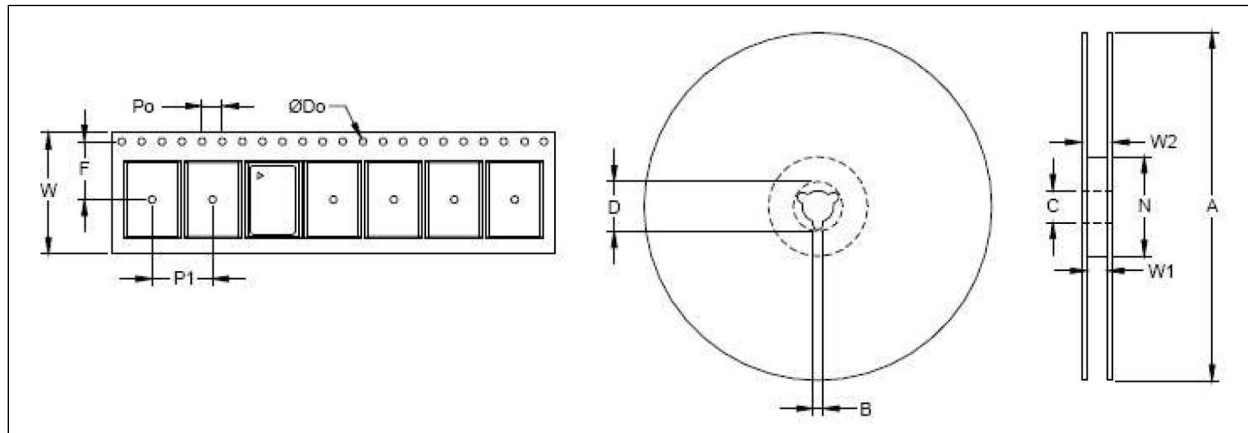

7.0 PACKAGING INFORMATION

6-Lead 7 mm x 5 mm LDFN Package Outline and Recommended Land Pattern

Note: For the most current package drawings, please see the Microchip Packaging Specification located at <http://www.microchip.com/packaging>

Marking Information:

XXXMXX = Frequency (example: 100M00)

YY = Year of Manufacture

WW = Week of the Year

C = Manufacturing Location

▲ = Pin 1 Indicator

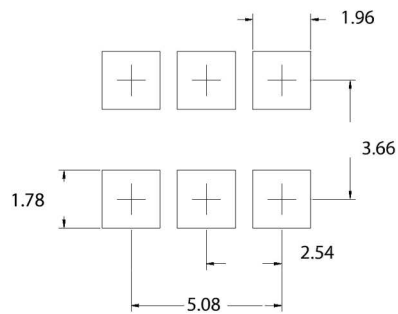
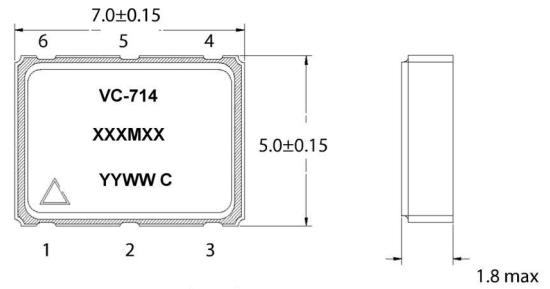

Pad Layout

Units are mm

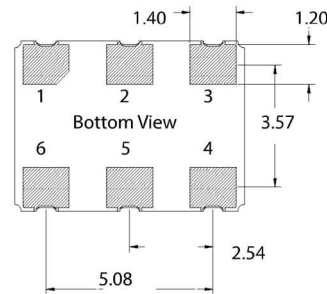

VC-714

NOTES:

APPENDIX A: REVISION HISTORY

Revision A (May 2021)

- Converted Vectron document VC-714 to Microchip data sheet template DS20006509A.
- Minor grammatical text changes throughout.

Revision B (August 2021)

- Added a plus/minus (\pm) symbol to each value listed for Output Amplitude in the [Electrical Characteristics, LVDS Option](#) table.

Revision C (July 2022)

- Added “_SNPB= Tin Lead Solder Dipped” packaging type information to the [Product Identification System](#) page.
- Replaced [Figure 5-1](#) and [Table 5-1](#) with current data.
- Minor text and image corrections where needed.

Revision D (July 2023)

- Added the -55°C to $+125^{\circ}\text{C}$ temperature range option throughout.
- Updated temperature values in [Table 5-1](#).
- Added new frequencies to the [Standard Output Frequencies](#) table.
- Updated package marking information.
- Updated [Figure 1-1](#).
- Added note below [Figure 1-1](#).

Revision E (September 2024)

- Added HCSL option in multiple places.
- Added [Electrical Characteristics, HCSL Option](#) and [Figure 1-4](#).
- Updated options in the [Product Identification System](#).

VC-714

NOTES:

PRODUCT IDENTIFICATION SYSTEM

To order or obtain information, e.g., on pricing or delivery, contact your local Microchip representative or sales office.

<u>Device</u>	<u>-X</u>	<u>X</u>	<u>X</u>	<u>-X</u>	<u>X</u>	<u>X</u>	<u>X</u>	<u>-XXXXXXXXXX</u>	<u>XX</u>
Part No.	Power Supply	Output	Temp. Range	Stability	E/D Logic	E/D Pin	Custom Options	Frequency	Packaging
Device:	VC-714:	LVPECL, LVDS Crystal Oscillator in 6-Lead 7 mm x 5 mm LDFN							
Power Supply:	E =	3.3VDC ±5%							
	H =	2.5VDC ±5%							
	J =	1.8VDC ±5%							
Output:	C =	LVPECL							
	D =	LVDS							
	H =	HCSL							
Temperature Range:	C =	-55°C to +125°C							
	E =	-40°C to +85°C							
	F =	-40°C to +105°C							
	G =	-40°C to +125°C							
	W =	-10°C to +70°C							
Stability:	E =	±20 ppm							
	F =	±25 ppm							
	G =	±30 ppm							
	K =	±50 ppm							
	S =	±100 ppm							
Enable/Disable Logic:	A =	Output Enabled with a Logic High or Open							
	N =	No E/D							
Enable/Disable Pin:	A =	Pin 1 (Pin 2 = No Connect)							
	B =	Pin 2 (Pin 1 = No Connect)							
	X =	No Enable/Disable (Pin 1/2 No Connect)							
Custom Options:	N =	Standard option							
Frequency:	xxxMxxxxx=Frequency in MHz								
Packaging:	TR =	1,000/Reel							
	<blank>=	Cut Tape/ non-TR quantities							
	_SNPB=	Tin Lead Solder Dipped							
Examples:									
a) VC-714-ECE-FAAN-200M000000TR: VC-714, 3.3VDC, LVPECL Output, -40°C to +85°C Temp Range, ±25 ppm Stability, Output Enabled, Pin 1 Enable/Disable, Standard Option, 200 MHz, 1000/Reel									
b) VC-714-HDW-KAAN-125M000000TR: VC-714, 2.5VDC, LVDS Output, -10°C to +70°C Temp Range, ±50 ppm Stability, Output Enabled, Pin 1 Enable/Disable, Standard Option, 125 MHz, 1000/Reel									
c) VC-714-JHF-GNXN-106M250000TR: VC-714, 1.8VDC, HCSL Output, -40°C to +105°C Temp Range, ±30 ppm Stability, No Enable/Disable, No Enable/Disable, Standard Option, 106.25 MHz, 1000/Reel									
Note 1: Tape and Reel identifier only appears in the catalog part number description. This identifier is used for ordering purposes and is not printed on the device package. Check with your Microchip Sales Office for package availability with the Tape and Reel option.									

Note: Not all combinations of options are available. Other specifications may be available upon request.

TABLE 1: STANDARD OUTPUT FREQUENCIES

100.000 MHz	106.250 MHz	120.000 MHz	125.000 MHz	156.250 MHz	159.375 MHz
160.000 MHz	161.1328 MHz	200.000 MHz	240.000 MHz	250.000 MHz	264.000 MHz
312.500 MHz	—	—	—	—	—

VC-714

NOTES:

Note the following details of the code protection feature on Microchip products:

- Microchip products meet the specifications contained in their particular Microchip Data Sheet.
- Microchip believes that its family of products is secure when used in the intended manner, within operating specifications, and under normal conditions.
- Microchip values and aggressively protects its intellectual property rights. Attempts to breach the code protection features of Microchip product is strictly prohibited and may violate the Digital Millennium Copyright Act.
- Neither Microchip nor any other semiconductor manufacturer can guarantee the security of its code. Code protection does not mean that we are guaranteeing the product is "unbreakable" Code protection is constantly evolving. Microchip is committed to continuously improving the code protection features of our products.

This publication and the information herein may be used only with Microchip products, including to design, test, and integrate Microchip products with your application. Use of this information in any other manner violates these terms. Information regarding device applications is provided only for your convenience and may be superseded by updates. It is your responsibility to ensure that your application meets with your specifications. Contact your local Microchip sales office for additional support or, obtain additional support at <https://www.microchip.com/en-us/support/design-help/client-support-services>.

THIS INFORMATION IS PROVIDED BY MICROCHIP "AS IS". MICROCHIP MAKES NO REPRESENTATIONS OR WARRANTIES OF ANY KIND WHETHER EXPRESS OR IMPLIED, WRITTEN OR ORAL, STATUTORY OR OTHERWISE, RELATED TO THE INFORMATION INCLUDING BUT NOT LIMITED TO ANY IMPLIED WARRANTIES OF NON-INFRINGEMENT, MERCHANTABILITY, AND FITNESS FOR A PARTICULAR PURPOSE, OR WARRANTIES RELATED TO ITS CONDITION, QUALITY, OR PERFORMANCE.

IN NO EVENT WILL MICROCHIP BE LIABLE FOR ANY INDIRECT, SPECIAL, PUNITIVE, INCIDENTAL, OR CONSEQUENTIAL LOSS, DAMAGE, COST, OR EXPENSE OF ANY KIND WHATSOEVER RELATED TO THE INFORMATION OR ITS USE, HOWEVER CAUSED, EVEN IF MICROCHIP HAS BEEN ADVISED OF THE POSSIBILITY OR THE DAMAGES ARE FORESEEABLE. TO THE FULLEST EXTENT ALLOWED BY LAW, MICROCHIP'S TOTAL LIABILITY ON ALL CLAIMS IN ANY WAY RELATED TO THE INFORMATION OR ITS USE WILL NOT EXCEED THE AMOUNT OF FEES, IF ANY, THAT YOU HAVE PAID DIRECTLY TO MICROCHIP FOR THE INFORMATION.

Use of Microchip devices in life support and/or safety applications is entirely at the buyer's risk, and the buyer agrees to defend, indemnify and hold harmless Microchip from any and all damages, claims, suits, or expenses resulting from such use. No licenses are conveyed, implicitly or otherwise, under any Microchip intellectual property rights unless otherwise stated.

For information regarding Microchip's Quality Management Systems, please visit www.microchip.com/quality.

Trademarks

The Microchip name and logo, the Microchip logo, Adaptec, AVR, AVR logo, AVR Freaks, BesTime, BitCloud, CryptoMemory, CryptoRF, dsPIC, flexPWR, HELDO, IGLOO, JukeBlox, KeeLoq, Kleer, LANCheck, LinkMD, maXStylus, maXTouch, MediaLB, megaAVR, Microsemi, Microsemi logo, MOST, MOST logo, MPLAB, OptoLyzor, PIC, picoPower, PICSTART, PIC32 logo, PolarFire, Prochip Designer, QTouch, SAM-BA, SenGenuity, SpyNIC, SST, SST Logo, SuperFlash, Symmetricom, SyncServer, Tachyon, TimeSource, tinyAVR, UNI/O, Vectron, and XMEGA are registered trademarks of Microchip Technology Incorporated in the U.S.A. and other countries.

AgileSwitch, ClockWorks, The Embedded Control Solutions Company, EtherSynch, Flashtec, Hyper Speed Control, HyperLight Load, Libero, motorBench, mTouch, Powermite 3, Precision Edge, ProASIC, ProASIC Plus, ProASIC Plus logo, Quiet-Wire, SmartFusion, SyncWorld, TimeCesium, TimeHub, TimePictra, TimeProvider, and ZL are registered trademarks of Microchip Technology Incorporated in the U.S.A.

Adjacent Key Suppression, AKS, Analog-for-the-Digital Age, Any Capacitor, AnyIn, AnyOut, Augmented Switching, BlueSky, BodyCom, Clockstudio, CodeGuard, CryptoAuthentication, CryptoAutomotive, CryptoCompanion, CryptoController, dsPICDEM, dsPICDEM.net, Dynamic Average Matching, DAM, ECAN, Espresso T1S, EtherGREEN, EyeOpen, GridTime, IdealBridge, IGaT, In-Circuit Serial Programming, ICSP, INICnet, Intelligent Paralleling, IntelliMOS, Inter-Chip Connectivity, JitterBlocker, Knob-on-Display, MarginLink, maxCrypto, maxView, memBrain, Mindi, MiWi, MPASM, MPF, MPLAB Certified logo, MPLIB, MPLINK, mSiC, MultiTRAK, NetDetach, Omniscient Code Generation, PICDEM, PICDEM.net, PICkit, PICtail, Power MOS IV, Power MOS 7, PowerSmart, PureSilicon, QMatrix, REAL ICE, Ripple Blocker, RTAX, RTG4, SAM-ICE, Serial Quad I/O, simpleMAP, SimpliPHY, SmartBuffer, SmartHLS, SMART-I.S., storClad, SQL, SuperSwitcher, SuperSwitcher II, Switchtec, SynchroPHY, Total Endurance, Trusted Time, TSHARC, Turing, USBCheck, VariSense, VectorBlox, VeriPHY, ViewSpan, WiperLock, XpressConnect, and ZENA are trademarks of Microchip Technology Incorporated in the U.S.A. and other countries.

SQTP is a service mark of Microchip Technology Incorporated in the U.S.A.

The Adaptec logo, Frequency on Demand, Silicon Storage Technology, and Symmcom are registered trademarks of Microchip Technology Inc. in other countries.

GestIC is a registered trademark of Microchip Technology Germany II GmbH & Co. KG, a subsidiary of Microchip Technology Inc., in other countries.

All other trademarks mentioned herein are property of their respective companies.

© 2021 - 2024, Microchip Technology Incorporated and its subsidiaries.

All Rights Reserved.

ISBN: 978-1-6683-0259-0



MICROCHIP

Worldwide Sales and Service

AMERICAS

Corporate Office
2355 West Chandler Blvd.
Chandler, AZ 85224-6199
Tel: 480-792-7200
Fax: 480-792-7277
Technical Support:
<http://www.microchip.com/support>
Web Address:
www.microchip.com

Atlanta
Duluth, GA
Tel: 678-957-9614
Fax: 678-957-1455

Austin, TX
Tel: 512-257-3370

Boston
Westborough, MA
Tel: 774-760-0087
Fax: 774-760-0088

Chicago
Itasca, IL
Tel: 630-285-0071
Fax: 630-285-0075

Dallas
Addison, TX
Tel: 972-818-7423
Fax: 972-818-2924

Detroit
Novi, MI
Tel: 248-848-4000

Houston, TX
Tel: 281-894-5983

Indianapolis
Noblesville, IN
Tel: 317-773-8323
Fax: 317-773-5453
Tel: 317-536-2380

Los Angeles
Mission Viejo, CA
Tel: 949-462-9523
Fax: 949-462-9608
Tel: 951-273-7800

Raleigh, NC
Tel: 919-844-7510

New York, NY
Tel: 631-435-6000

San Jose, CA
Tel: 408-735-9110
Tel: 408-436-4270

Canada - Toronto
Tel: 905-695-1980
Fax: 905-695-2078

ASIA/PACIFIC

Australia - Sydney
Tel: 61-2-9868-6733

China - Beijing
Tel: 86-10-8569-7000

China - Chengdu
Tel: 86-28-8665-5511

China - Chongqing
Tel: 86-23-8980-9588

China - Dongguan
Tel: 86-769-8702-9880

China - Guangzhou
Tel: 86-20-8755-8029

China - Hangzhou
Tel: 86-571-8792-8115

China - Hong Kong SAR
Tel: 852-2943-5100

China - Nanjing
Tel: 86-25-8473-2460

China - Qingdao
Tel: 86-532-8502-7355

China - Shanghai
Tel: 86-21-3326-8000

China - Shenyang
Tel: 86-24-2334-2829

China - Shenzhen
Tel: 86-755-8864-2200

China - Suzhou
Tel: 86-186-6233-1526

China - Wuhan
Tel: 86-27-5980-5300

China - Xian
Tel: 86-29-8833-7252

China - Xiamen
Tel: 86-592-2388138

China - Zhuhai
Tel: 86-756-3210040

ASIA/PACIFIC

India - Bangalore
Tel: 91-80-3090-4444

India - New Delhi
Tel: 91-11-4160-8631

India - Pune
Tel: 91-20-4121-0141

Japan - Osaka
Tel: 81-6-6152-7160

Japan - Tokyo
Tel: 81-3-6880-3770

Korea - Daegu
Tel: 82-53-744-4301

Korea - Seoul
Tel: 82-2-554-7200

Malaysia - Kuala Lumpur
Tel: 60-3-7651-7906

Malaysia - Penang
Tel: 60-4-227-8870

Philippines - Manila
Tel: 63-2-634-9065

Singapore
Tel: 65-6334-8870

Taiwan - Hsin Chu
Tel: 886-3-577-8366

Taiwan - Kaohsiung
Tel: 886-7-213-7830

Taiwan - Taipei
Tel: 886-2-2508-8600

Thailand - Bangkok
Tel: 66-2-694-1351

Vietnam - Ho Chi Minh
Tel: 84-28-5448-2100

EUROPE

Austria - Wels
Tel: 43-7242-2244-39
Fax: 43-7242-2244-393

Denmark - Copenhagen
Tel: 45-4485-5910
Fax: 45-4485-2829

Finland - Espoo
Tel: 358-9-4520-820

France - Paris
Tel: 33-1-69-53-63-20
Fax: 33-1-69-30-90-79

Germany - Garching
Tel: 49-8931-9700

Germany - Haan
Tel: 49-2129-3766400

Germany - Heilbronn
Tel: 49-7131-72400

Germany - Karlsruhe
Tel: 49-721-625370

Germany - Munich
Tel: 49-89-627-144-0
Fax: 49-89-627-144-44

Germany - Rosenheim
Tel: 49-8031-354-560

Israel - Hod Hasharon
Tel: 972-9-775-5100

Italy - Milan
Tel: 39-0331-742611
Fax: 39-0331-466781

Italy - Padova
Tel: 39-049-7625286

Netherlands - Drunen
Tel: 31-416-690399
Fax: 31-416-690340

Norway - Trondheim
Tel: 47-7288-4388

Poland - Warsaw
Tel: 48-22-3325737

Romania - Bucharest
Tel: 40-21-407-87-50

Spain - Madrid
Tel: 34-91-708-08-90
Fax: 34-91-708-08-91

Sweden - Gothenberg
Tel: 46-31-704-60-40

Sweden - Stockholm
Tel: 46-8-5090-4654

UK - Wokingham
Tel: 44-118-921-5800
Fax: 44-118-921-5820