Bluetooth® Dual Mode Speaker Audio Application

Introduction

Microchip's BM6x Bluetooth audio modules support simultaneous operation of Bluetooth Classic and Bluetooth Low Energy (BLE). The module's Dual Mode Speaker (DSPK) firmware can be used in a variety of end applications such as small, medium and large speakers driving an audio amplifier.

The following figure illustrates a typical Bluetooth application.

Figure 1. Typical Bluetooth Application



The following figure illustrates a typical Aux-in audio source application.

Figure 2. Typical Aux-in Audio Source Application

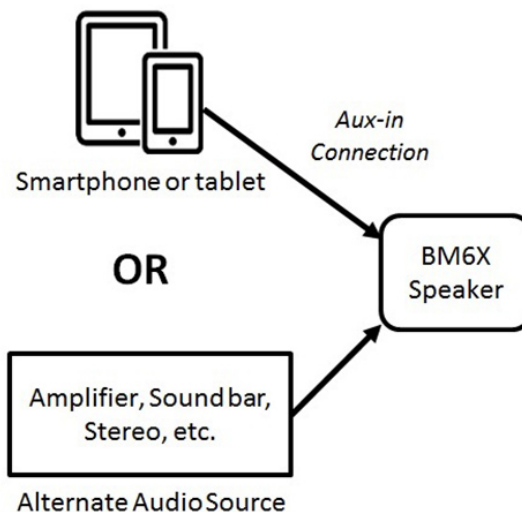

In addition to supporting audio and BLE profiles, DSPK works with the Microchip Bluetooth Audio (MBA) app, which is compatible with Android™ and iOS devices. With DSPK, consumers can use the app to configure the BM6x module for optimal sound performance in single speaker applications. The app is configured to allow the BM6x module to communicate with other BLE-enabled devices to issue OEM-specific commands, such as controlling light. This allows customers the flexibility to add differentiating features to their applications. A host MCU is not required for standard operation of the firmware.

Requirements

DSPK is supported on BM62 and BM64. BM64 is used for applications that require an I2S digital output. Please refer to the BM62/64 Bluetooth stereo data sheet (DS60001403A) for the full capabilities of the BM6X device.

1. Documentation
 - BM64 EVB User's Guide (DS50002514A)
 - BM62/64 Bluetooth 4.2 Stereo Audio Module Data Sheet (DS60001403A)
2. Hardware
 - BM62 EVB or BM64 EVB
 - Bluetooth-enabled device:
 - Android™: Android 6.0 or later version
 - iOS: iOS 10 or later version.
 - Windows® host PC with USB port
 - Speaker, microphone or headset
 - Micro-USB cable
 - 15 V supply
 - Aux-in enabled audio streaming device
 - Speaker that accepts L+/-, R+/- as input
3. Software
 - Firmware: DSPK V2.x.y
 - MCU: PIC18 DSPK V2.x.y (only for BM64)
 - EEPROM Table: Customized EEPROM table (*.ipf)
 - Microchip Bluetooth Audio (MBA) mobile app
4. Tools
 - The DSPK v2.x.y package contains all the required tools.
Note: Please download DSPK v2.x.y package for BM62 from: www.microchip.com/BM62.
Note: Please download DSPK v2.x.y package for BM64 from: www.microchip.com/BM64.

Table of Contents

Introduction.....	1
Requirements.....	2
1. Demo Setup.....	5
1.1. Demonstration Using BM62 EVB.....	5
1.2. Demonstration Using the BM64 EVB.....	8
1.3. Firmware Capabilities and Features.....	22
2. Package Contents.....	25
3. Supported Devices.....	26
4. Appendix A: BM62 Customized Parameters.....	27
4.1. Customization of UI parameters.....	27
4.2. Customizing DSP Parameters.....	32
4.3. Creating the *.ipf file.....	33
5. Appendix B: BM64 Customized Parameters.....	40
5.1. Customization of UI Parameters.....	40
5.2. Customization of the DSP Parameters.....	48
5.3. Creating *.ipf file.....	50
6. Appendix C: BM64 I2S Master/Slave Mode.....	51
6.1. Selecting UI Parameters.....	51
6.2. Selecting DSP Parameters.....	51
6.3. Creating *.ipf file.....	52
7. Appendix D: BLE Status in Power Off Mode.....	53
8. Appendix E: BLE Configuration-Power Off.....	54
9. Appendix F: MBA Power Mode.....	55
10. Appendix G: Customized Voice Prompt.....	56
11. Appendix H: Enabling UART in BM62.....	57
12. Appendix I: MBA Application Installation.....	58
13. Appendix J: Configuring HID over GATT.....	63
14. Appendix K: Routing Audio to SPK in BM64.....	65
15. Appendix L: UPLINK SRC(48K->8K/16K), Voice, and Tone Stereo.....	66
16. Appendix M: AVRCP Selection.....	68
17. Appendix N: BLE Advertisement Name.....	69
18. Document Revision History.....	71
The Microchip Website.....	72

Product Change Notification Service.....	72
Customer Support.....	72
Microchip Devices Code Protection Feature.....	72
Legal Notice.....	72
Trademarks.....	73
Quality Management System.....	73
Worldwide Sales and Service.....	74

1. Demo Setup

DSPK v2.x.y works with BM62 and BM64 EVB. BM62 EVB doesn't have an external MCU, but BM64 has an external MCU to control BM64 through UART. BM62 EVB and BM64 EVB are different and buttons are also different. Hence, demonstration for BM62 EVB and BM64 EVB will be discussed separately.

1.1 Demonstration Using BM62 EVB

1.1.1 BM62 Setup

1. Update firmware from the DSPK v2.x.y package. Refer to section 3.6 of the BM62 EVB User's Guide (70005260A.pdf).
2. Update EEPROM with the EEPROM table provided in the DSPK v2.x.y package. Refer to section 3.5 of the BM62 EVB User's Guide (70005260A.pdf). One EEPROM table has been provided in the package; however, the customer can customize the UI and DSP setting to create their customized EEPROM table. Please refer to [Appendix A](#) for details.
3. Connect the speaker to SPK.
4. Power-up: Connect USB to P1 (a battery can also be used to power-up, please connect 4.2 V and higher Lithium Ion battery to JP19/JP20).
5. Install the MBA app on a smart phone (Android 6.0 or higher /iOS 10.0 and higher device).
Note: The Android version of the MBA app is available from the Google Play™ store and the iOS version is available in the iTunes® store. The MBA app(Android/iOS) is also provided in the DSPK v2.x.y package. Refer to [Appendix I](#) to install the MBA1_x_Android.apk app on an Android device.

1.1.2 Button Functionality on BM62 EVB

- Long press MFB: power on/off
- Very long press MFB: enter into pairing mode
- Short press Btn1: play/pause
- Short press Btn2: volume up
- Short press Btn3: volume down
- Short press Btn4: next song
- Short press Btn5: previous song

These are default settings and can be changed through the UI tool. See [Appendix A](#) for details.

Note: Long press is longer than 1 sec., very long press is longer than 10 sec., and short press is less than 1 sec.

1.1.3 Using Button Functionality

Long press and hold MFB. The device will power on and a voice prompt "power on" will sound. Keep pressing MFB and the device will go into Pairing mode. Red and Blue LEDs will start flashing alternately and a voice prompt "ready to pair" will play out. Pair with the smart phone. Once pairing is complete, a voice prompt "pairing completed" will play out. Play music on the smart phone and music will be heard on the speaker connected with the BM62 EVB. Use various buttons to control the music.

Note: Audio will not be heard on the speaker without pairing completed.

1.1.4 Using the SPK Command Tool

The BM62 EVB can also be controlled through the SPK Command Tool. The SPK Command Tool is an MCU emulation tool to control BM6X devices through UART. The following are the steps to control through the SPK Command tool.

1. Enable UART as shown in [Appendix H](#).
2. Connect the BM62 EVB through USB to a PC.
3. Start SPKCommandSetTool.exe.
4. Follow steps 1 through 6 as shown in the following figure to get into Pairing mode.

Figure 1-1. SPK Command Set Tool

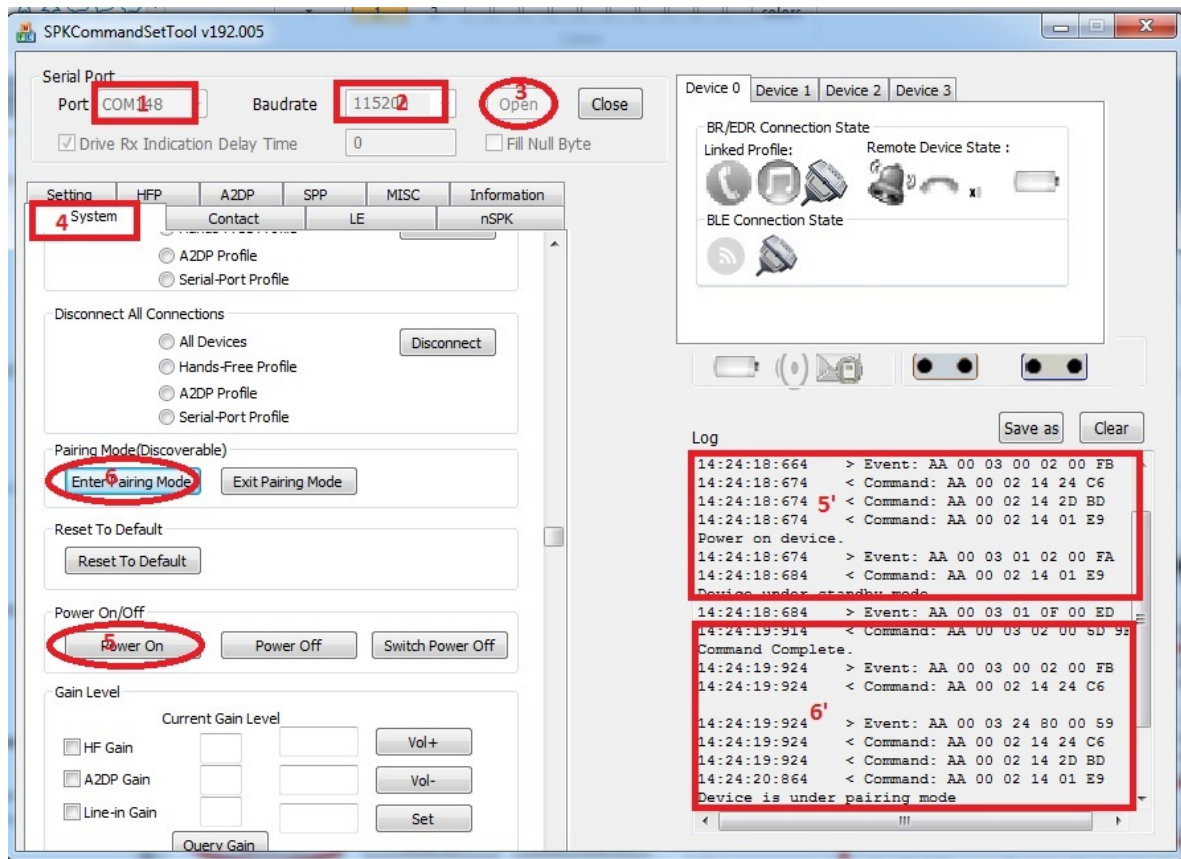

5. Pair and connect with the mobile phone and play music.
6. Music can also be controlled using the SPK Command Set Tool as shown in the following figure.

Figure 1-2. SPK Command Set Tool

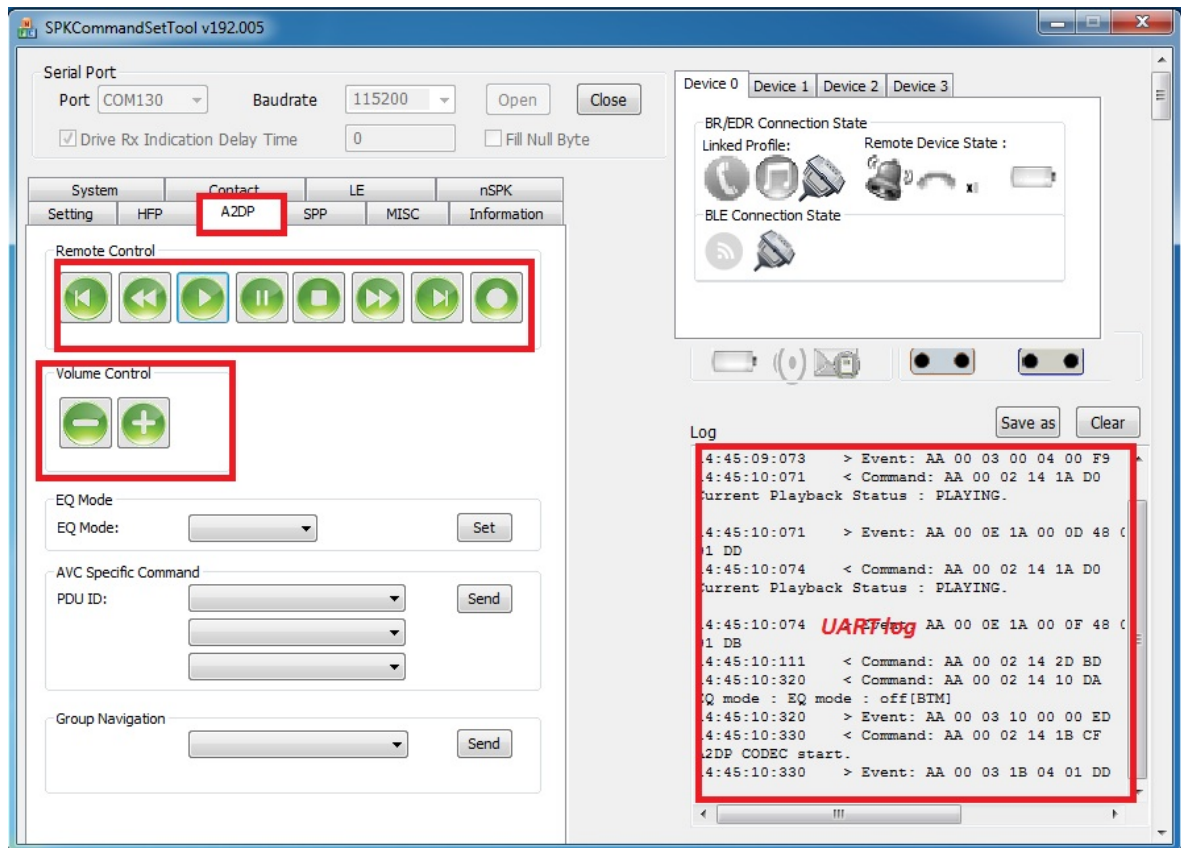

7. Commands can be sent using the SPK Command Set Tool as shown in the following figure.

Figure 1-3. SPK Command Set Tool

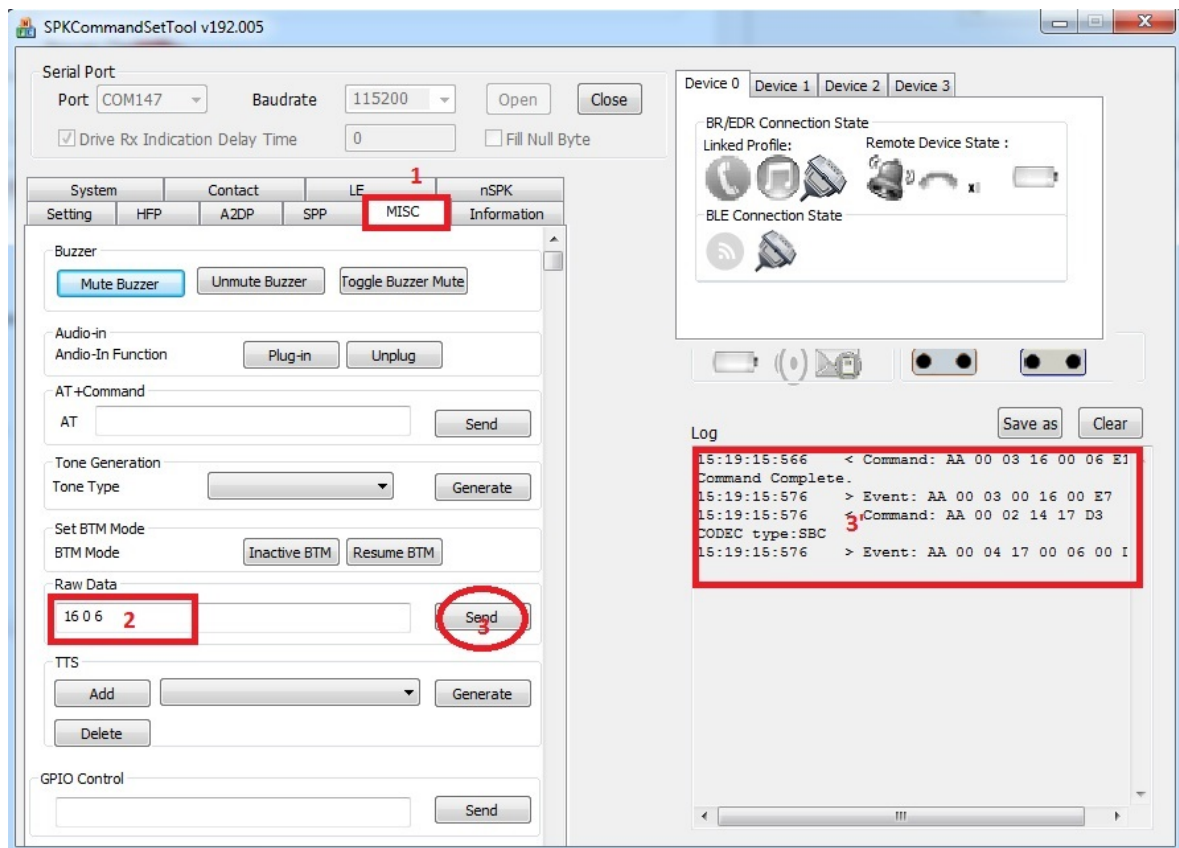

1.1.5 Using the MBA App

Refer to section [Demo with MBA App](#).

Note: UART needs to be disabled when using the MBA app with the BM62 EVB.

1.2 Demonstration Using the BM64 EVB

1.2.1 BM64 Setup

1. Software upgrade – upgrade the firmware and MCU code from the DSPK 2.x.y software package. For more information on the firmware and MCU update procedure, refer to the “BM64 EVB User’s Guide” (DS50002514A), Section 3.6 and Section 3.7 respectively. To program the EEPROM, refer to Section 3.5 of “BM64 EVB User’s Guide” (DS50002514A). One EEPROM table is provided in the package. If a customer wants to customize the UI and DSP setting, then refer to [Appendix B](#).
2. Connection – connect a speaker to R/L+/- on the BM64 EVB. Only one speaker needs to be connected.
3. Power-up – connect BM64 EVB to a 15 V supply and short press MFB on the EVB.
4. Installation – install the Microchip Bluetooth Audio App on Android 6.0 or higher device/iOS 10.0 and higher device. The MBA app is available from the Google Play store/iTunes store.

1.2.2 Button Functionality of the BM64 EVB

- MFB (SW24)
 - Short press: to power on/off
 - Long press: to enter into pairing mode
 - Very long press: to erase link key
- SW31

- Short press: to play/pause
- SW23
 - Short press: to go to previous song
 - Long press: fast forward
- SW45
 - Short press: to go to next song
 - Long press: fast forward
- SW27
 - Short press: volume up
 - Long press: volume up continuously
- SW28
 - Volume down
 - Volume down continuously
- SW40
 - Short press: toggle Aux-in and BT audio source
- SW22 : HID over GATT
 - Short press: mouse movement left
 - Double press: mouse movement downward
- SW39 Button: HID over GATT
 - Short press: mouse movement right
 - Double press: mouse movement upward

Note: Long press is longer than 1 sec., very long press is longer than 10 sec., short press is less than 1 sec.

1.2.3 Demonstration Using Button Press on the BM64 EVB

The following are steps to use buttons on the BM64 EVB.

1. Short press MFB: this will power-up BM64. A voice prompt "Power On" plays out and blue LED light starts flashing periodically.
2. Long press MFB: BM64 goes into pairing mode. A voice prompt "Ready to Pair" plays out, and blue/red LEDs start flashing alternately.
3. Pair and connect with a cell phone. A voice prompt "Pairing Completed" plays out.
4. Play music on the phone and music will be heard on the speaker connected to the BM64 EVB.
5. Use various buttons on the BM64 EVB to control music.
6. To demonstrate HFP, connect a microphone to MIC on the EVB and then receive a phone call on the device connected with BM6x.
7. To play audio through Aux-in, connect an audio streaming device through the Aux-in cable. Audio will be heard on the speaker. If Bluetooth audio was playing before the Aux-in cable was inserted, it will pause the Bluetooth audio and Aux-in audio will start playing. Short press SW40 on the BM64 EVB to toggle audio source between Bluetooth and Aux-in. When the Aux-in cable is removed, the Bluetooth audio will resume in its previous state.
Note: SPKCommandsetTool can be used to control the BM64 EVB but music will not be heard on L+/- R+/- . However, if BM64 is configured to play music on SPK (3.5 mm adapter jack) then this tool can be used. Please refer to [Appendix K](#) to route audio to SPK.

1.2.4 Demonstration with the MBA App

1. Press MFB on the BM64 EVB. Power also can be turned on using the MBA app as illustrated in [Appendix F](#).
2. Open the MBA App on a smart device (Android/iOS) as shown in the following figure.

Figure 1-4. Microchip Bluetooth Audio Android App

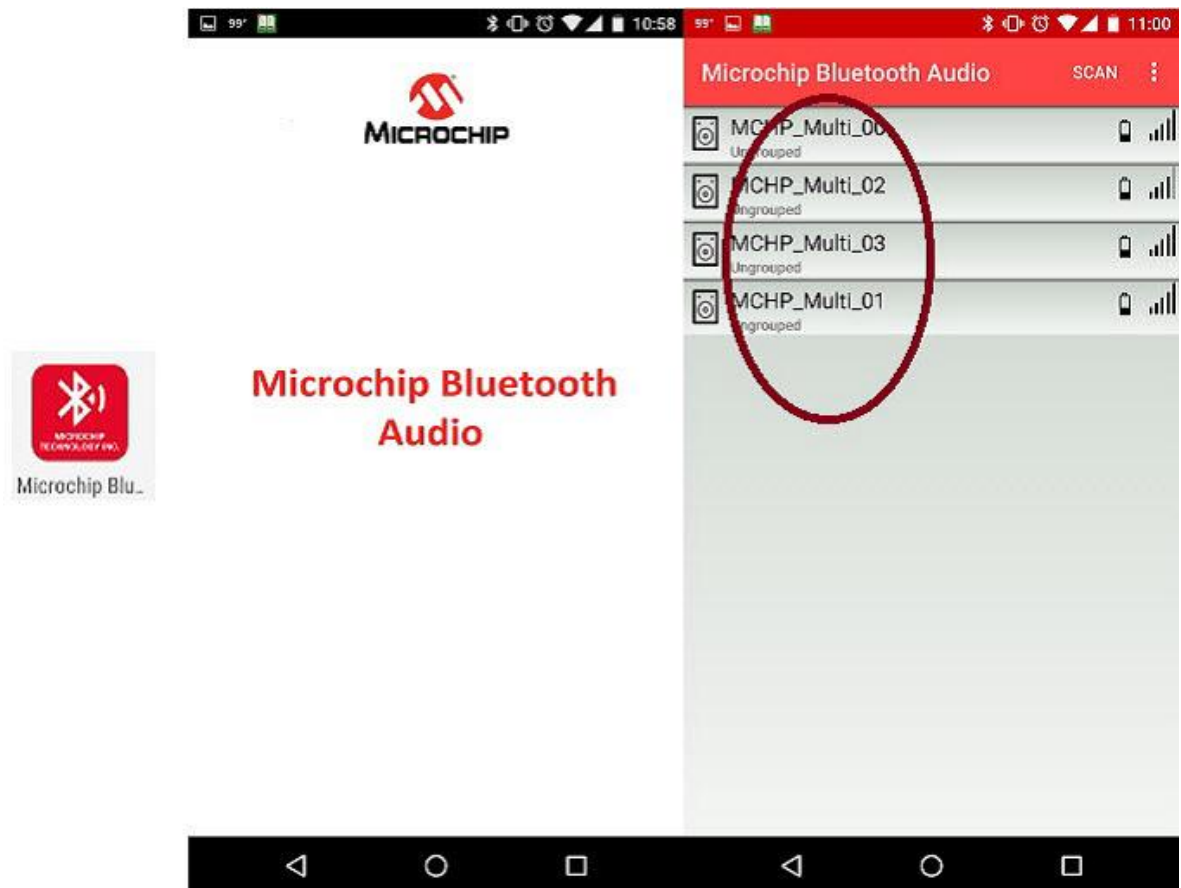

3. A list of connectable devices is displayed as shown in the above figure. Select any one device with BM6x_DSPKV2.x. The following screen is displayed as shown below.

Figure 1-5. Selecting the Speaker

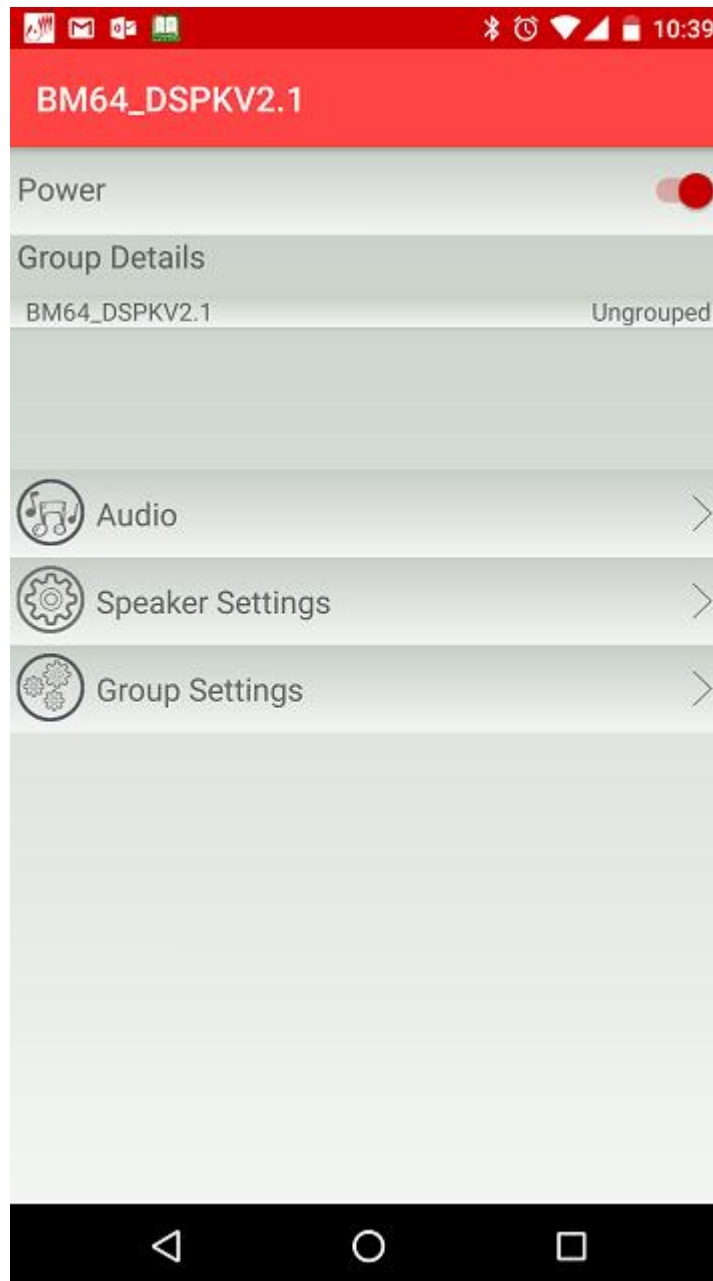

4. From the app, click **Audio** and select **Pairing Mode Enter** to enter pairing mode, as shown in the figure below. A voice prompt "Ready to Pair" sounds on BM64 EVB. Select Speaker Connection Connect, a list of discoverable Bluetooth devices will be displayed on the smart phone; select the device with the name BM6x_DSPKV2.x to pair and connect. The voice prompt "Pairing Completed" plays out.

Figure 1-6. Audio Connection

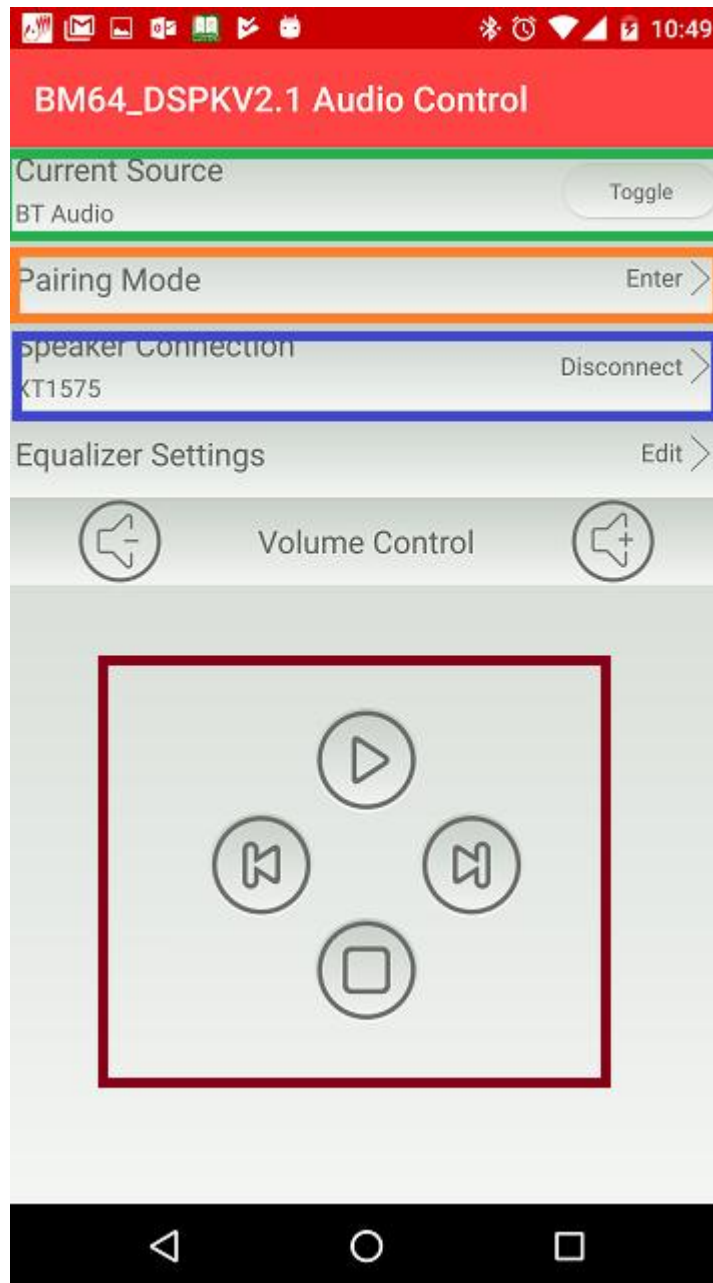

5. Control the music from the app through music as shown in the [Audio Connection](#). Click **play**, and music will start playing.
6. For Aux-In mode, connect an audio streaming device with BM64 EVB through audio Aux-In cable and play music. Music will play on the speaker.
7. To toggle the audio source, click the **Toggle** button on the app, as illustrated in the following figure.

Figure 1-7. MCHP Audio Control

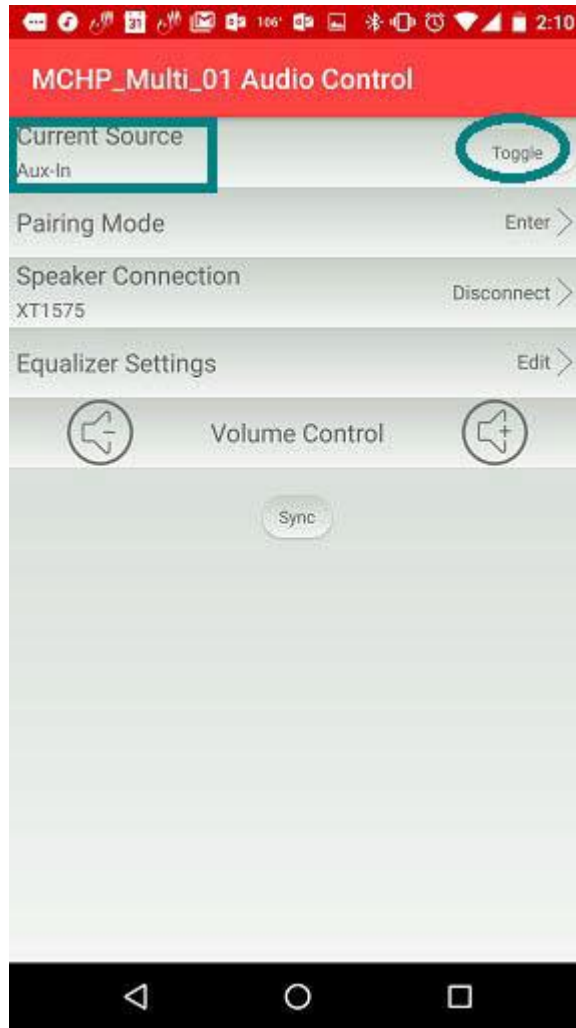

1.2.4.1 Renaming the Speaker

The speaker name can be changed from the app, as illustrated in the following figure. The change in speaker name is permanent - upon power cycle the speaker new name is retained.

Figure 1-8. Renaming Speaker



1.2.4.2 Equalizer Settings

The equalizer parameters can be set/changed from the Microchip Bluetooth audio application.

1. Select **Equalizer Settings** > **Edit** to edit the equalizer parameters, as illustrated in the following figure.

Figure 1-9. Editing Equalizer Settings

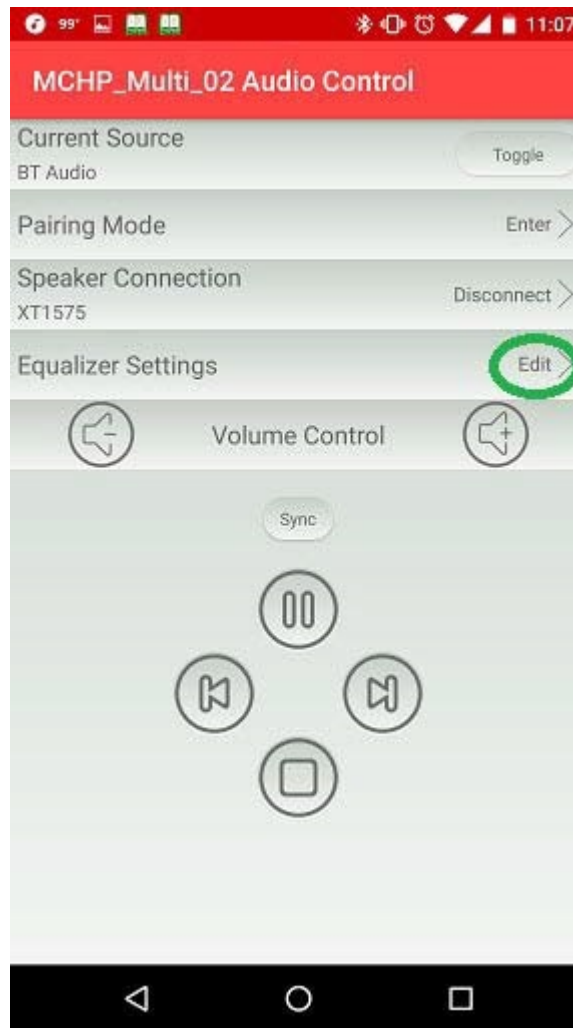

2. Select the standard equalizer parameters from the list, as illustrated in the following figure.

Figure 1-10. Selecting Equalizer Settings Parameters

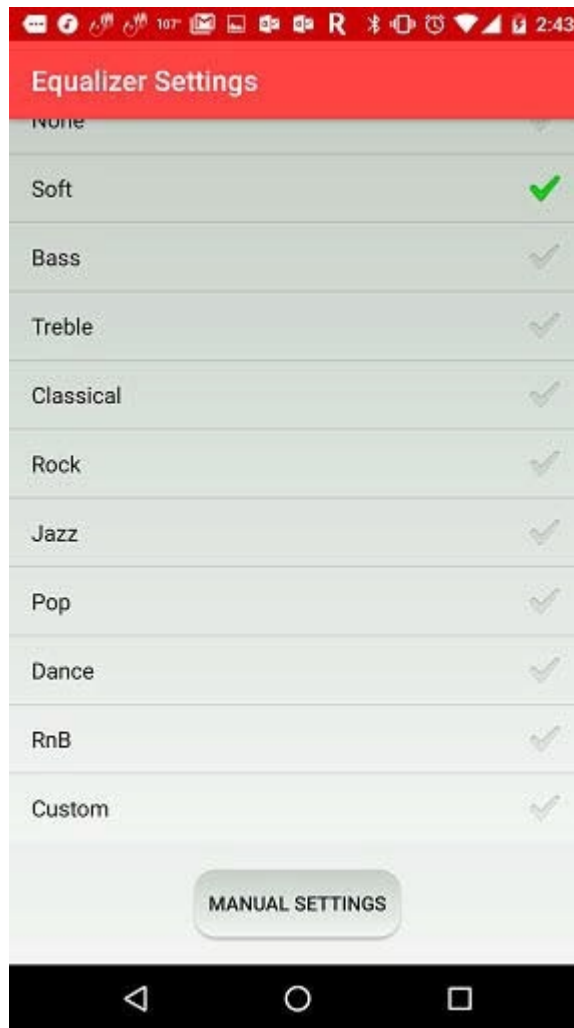

3. Select Manual Settings to set the equalizer parameters manually, as illustrated in the following figure.

Figure 1-11. Selecting Equalizer Parameters Manually

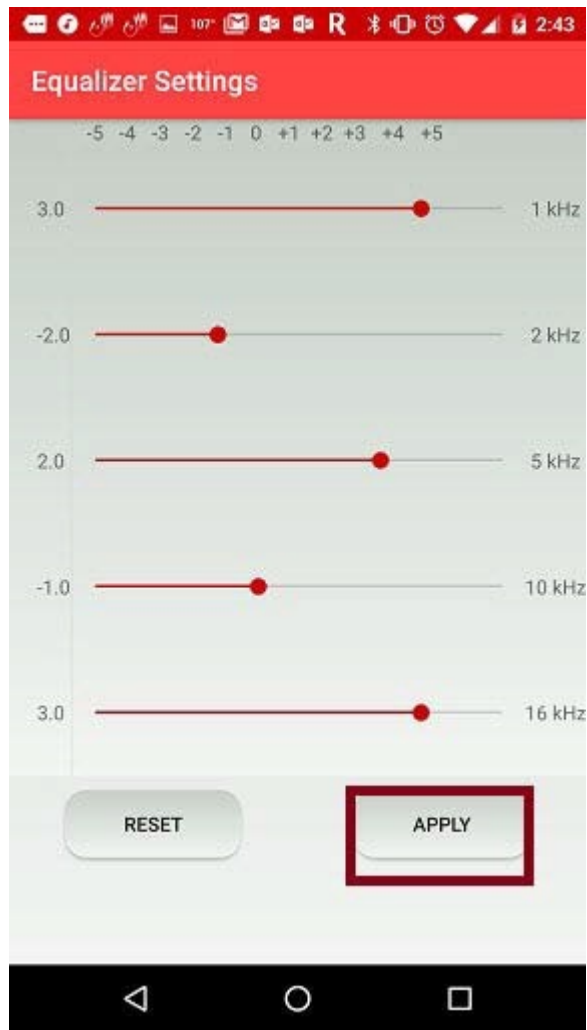

1.2.5 Firmware Version

The MBA app can be used to find out the firmware version. From the MBA app, click **Speaker Settings** as shown in the following figure.

Figure 1-12. MBA App Settings

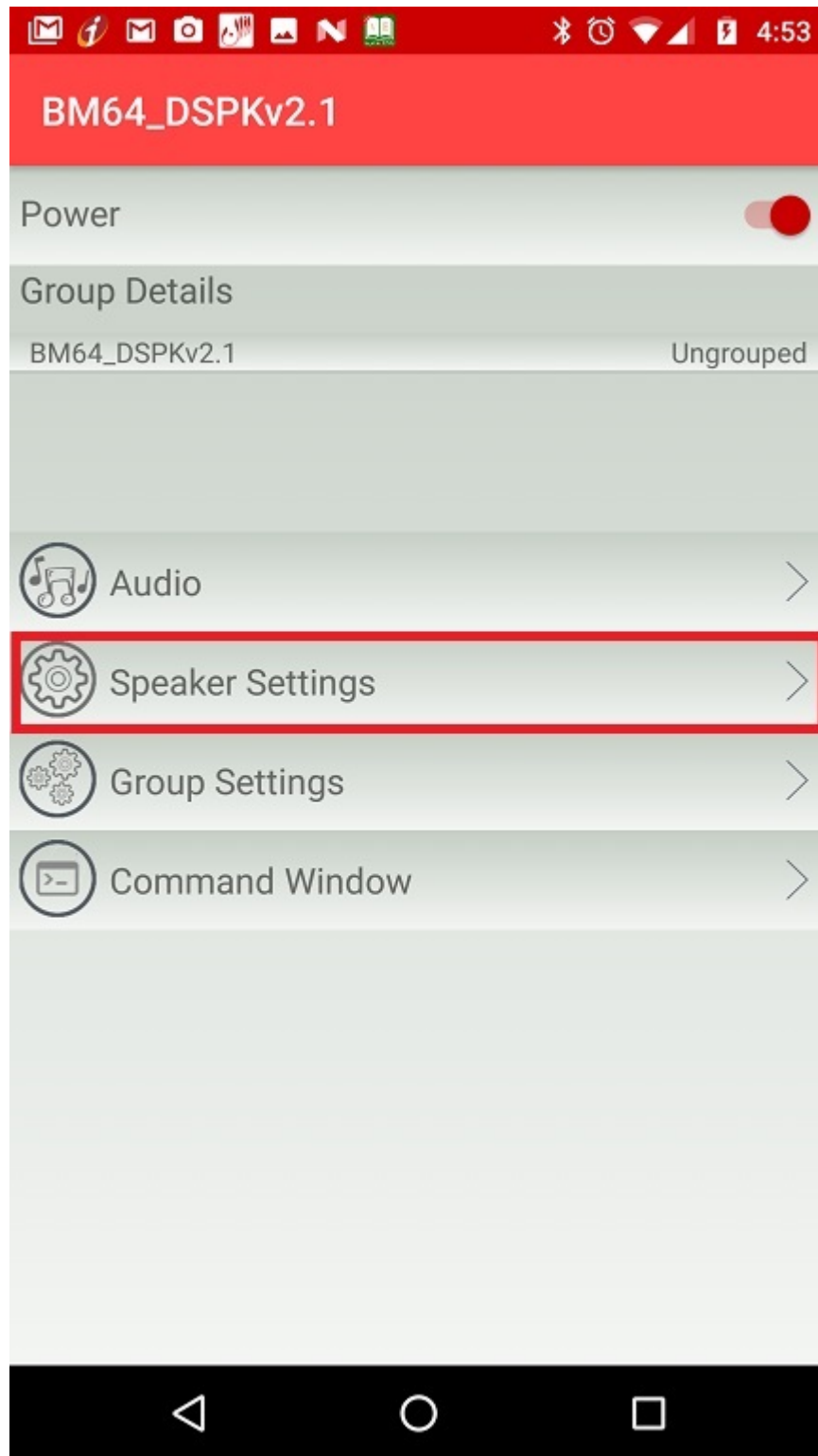

The following figure shows the firmware version. The firmware version can also be obtained by sending the Read_IC_Ver_Info command (0x32). Refer to this command in AudioUARTCommandSet_v2 02.docx (this document is the part of the DSPKv2.xx package).

Figure 1-13. MBA App Version Display

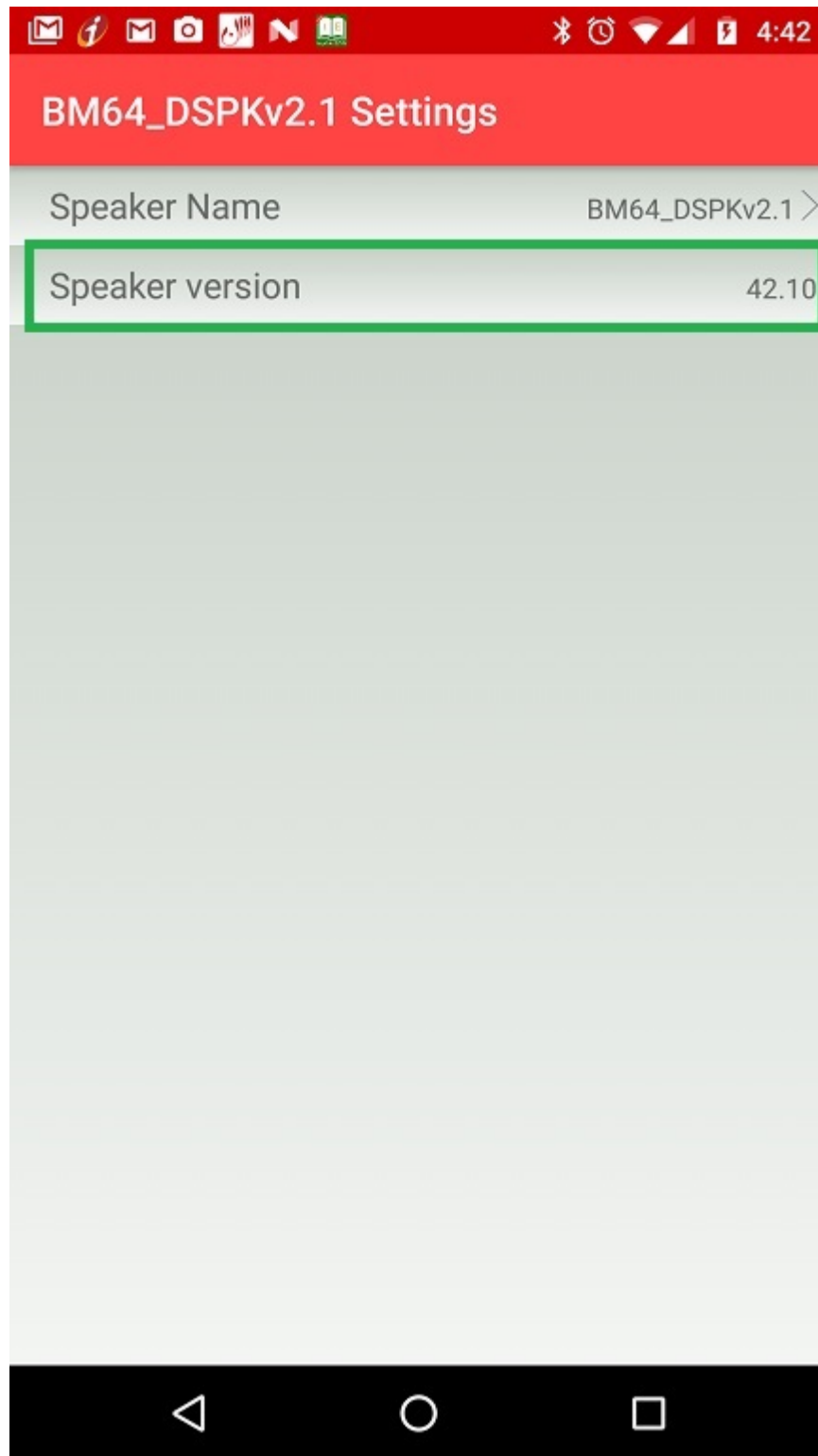

1.2.6 HID Mouse Demo

Program EEPROM with *MCHP_DSPKv2.1_BM64_GATT.ipf* provided in the *DSPK v2.x.y package*. The UI tool can be configured to enable this feature as illustrated in [Appendix J](#).

1. Power on BM64 by short pressing MFB
2. Long press MFB to enter into pairing mode
3. Scan for BT devices in the mobile phone. The following two devices will be discovered as shown in the following figure.

Figure 1-14. Scanning the Devices



4. Connect with each of the discovered devices(DSPKv2.x_BM64). One will show "**connected for call and media audio**" and another will show as "**connected as input device**" as shown in the following figure.

Figure 1-15. Discovering the Devices

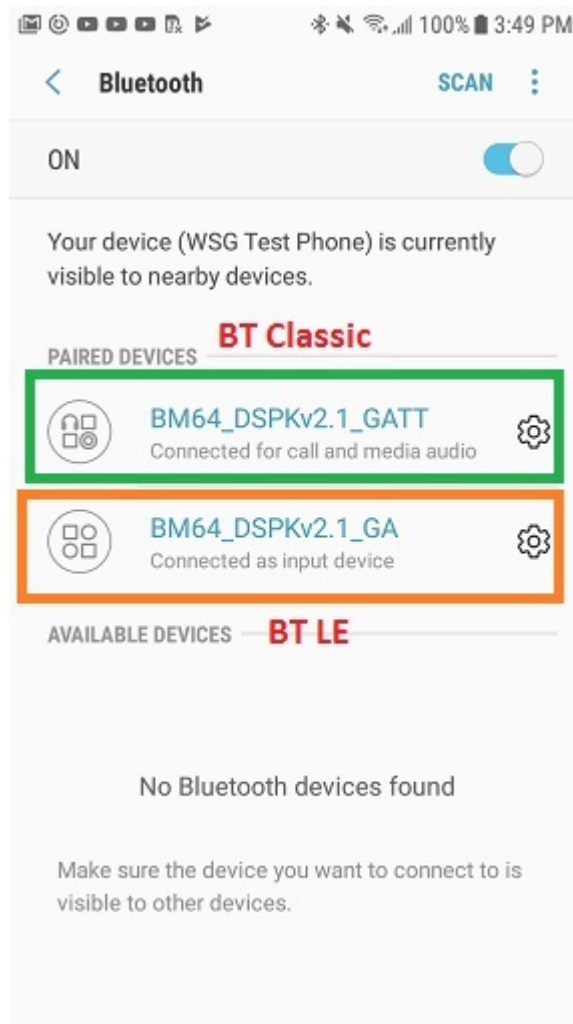

5. Go to the home screen of the phone and control the mouse pointer through button presses SW27 and SW39. A mouse pointer will appear as shown in the following figure.

Figure 1-16. Controlling the Mouse Pointer

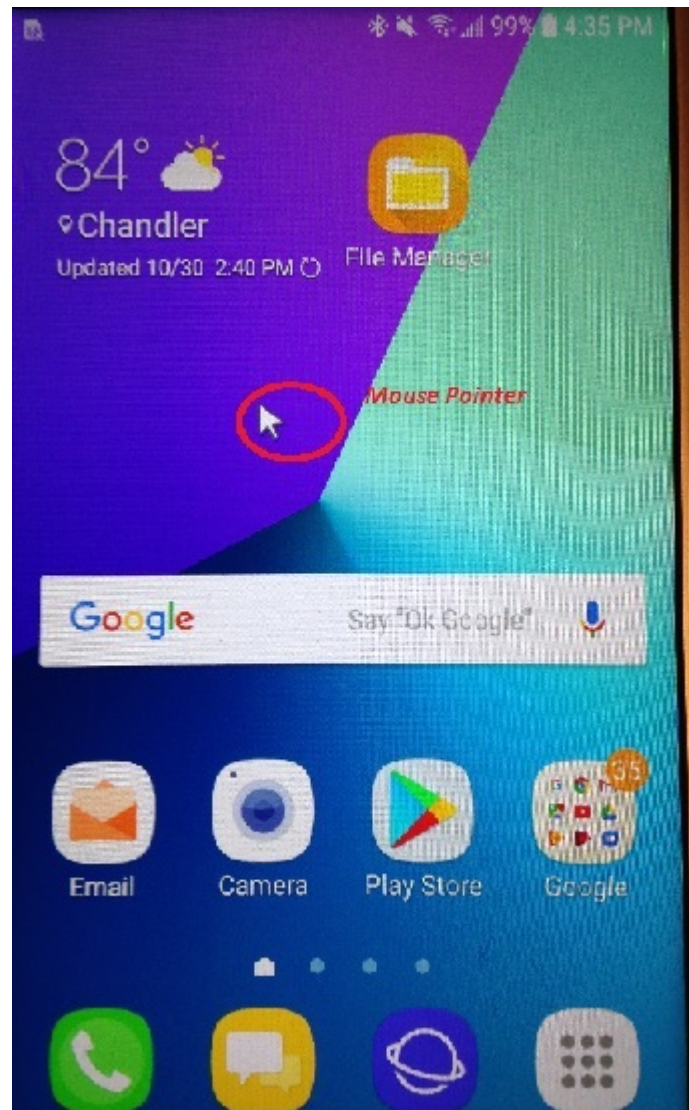

1.3 Firmware Capabilities and Features

The following features are supported in DSPK v2.x.y firmware.

- 7 native Voice Prompts (VPs) have been added. They can be enabled or disabled as shown in the [Voice Prompt Enable](#).
- A customized VP can be added through EEPROM. The VP must not be longer than 0.9 sec and must be saved as wave file @8kHz sampling rate. A maximum of 20 VPs can be added. EEPROM also stores UI and DSP settings, hence left over space in EEPROM can be utilized for customized VP storage. Refer to [10. Appendix G: Customized Voice Prompt](#). VP will be encoded by G.723.1 codec, thus voice files are preferable than the music files.
- Audio SRC (44.1k->48K) and Voice SRC (8/16K->48K) have been enabled in the downlink path. Please refer to [4. Appendix A: BM62 Customized Parameters](#) for details.
- Voice/tone can be enabled as stereo that are independent of SRC settings. Refer to [15. Appendix L: UPLINK SRC\(48K->8K/16K\), Voice, and Tone Stereo](#).
- BLE can be enabled/disabled while BM6x is in power-off. Refer to [8. Appendix E: BLE Configuration-Power Off](#).

- BLE can be configured to turn off while the BM6x device enters Pairing mode. Refer to [7. Appendix D: BLE Status in Power Off Mode](#).
- BTLE and BT classic can be enabled to have a different name and BT MAC address.
- BM64 can be configured as BM64 I2S Slave mode. Refer to [6. Appendix C: BM64 I2S Master/Slave Mode](#). It is preferred that when BM64 is configured as slave then ASRC and VSRC be enabled so that I2S need not be reconfigured for A2DP and HFP. I2S is configured for 48kHz in the beginning and left unchanged throughout the operation.
- BM64 can be configured to route audio to SPK. Refer to [14. Appendix K: Routing Audio to SPK in BM64](#).
- Uplink SRC (48K->8K/16K) has been added. Refer to [15. Appendix L: UPLINK SRC\(48K->8K/16K\), Voice, and Tone Stereo](#) for details.
- AVRCP can be downgraded to v1.3. Refer to [16. Appendix M: AVRCP Selection](#) for the details.
- BLE Advertisement name can be customized to any name. It can be independent of BT classic name. Refer to [17. Appendix N: BLE Advertisement Name](#)

1.3.1 Simultaneous Bluetooth and Aux-In Audio

Simultaneous Bluetooth audio and Aux-In audio are supported. The audio source can be toggled by short pressing SW40 on the BM64 EVB. This functionality is also available on the Microchip Bluetooth audio app, Refer [MCHP Audio Control](#).

1.3.2 MCU and CODEC

The DSPK V2.x.y code is developed and tested on the BM64 EVB/BM62 EVB. The BM64 EVB contains BM64 module, PIC18 (PIC18F85J10) MCU and a Yamaha DSP (YDA174A30). The MCU and DSP can be replaced by other devices.

Note: DSPK 2.x supports Codecs that operate at 48 kHz. An internal sample rate conversion is implemented to convert 44.1 kHz audio data to 48 kHz (ASRC). Similarly, narrow and wideband speech is converted from 8/16 kHz to 48 kHz (VSRC). Hence any Codec/Class D amplifier can be used. ASRC and VSRC can be selected in UI, refer to [Appendix C.1](#).

1.3.3 MCU and BM64 Communications

MCU communicates with the BM64 module through UART. A minimum set of hardware connections are required to interface MCU to the BM64 module. The following figure illustrates the minimum connections required by the relevant hardware pins on the BM64 module.

Figure 1-17. MCU Connection

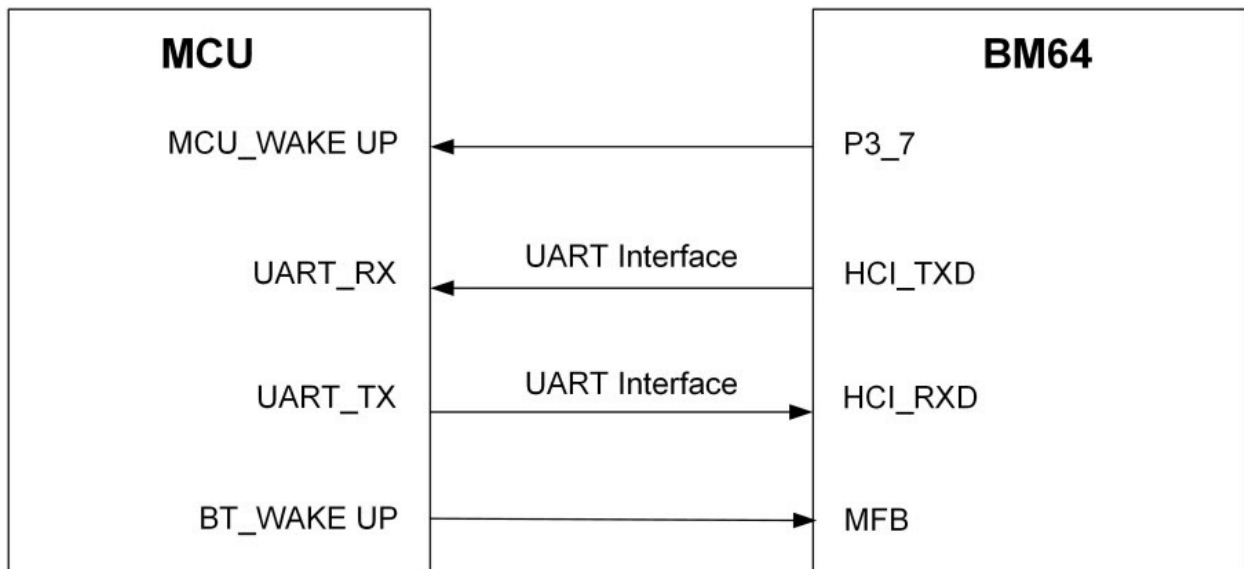

1.3.4 MCU Commands

MCU communicates with the BM64 module through UART commands. A summary of commands is provided in “AudioUARTCommandSet_Summary_table_V2.0x.xlsx” and command details are provided in “AudioUARTCommandSet_v2 0x.docx”. Both the documents are part of the DSPK V2.xx package.

2. Package Contents

The DSPK v2.x.y package contains the following:

1. DSPK Firmware v2.x.y (*.hex only)
2. Sample EEPROM table (*.ipf file), UI setting file (*.txt) and DSP setting file (*.txt)
3. PIC18 MCU code (binary and source code for BM64 only)
4. Microchip Bluetooth Audio Android/iOS App
5. Documentation
 - Application note
 - AudioUartCommandSet_V2 0x.docx
 - AudioUARTCommandSet_Summary_table_V2.0x.xlsx
 - Release Note
6. Tools
 - UI Tool
 - DSP Tool
 - isupdate (for BM64)
 - isbtflash (for BM62)
 - EEPROM Tool
 - UART Command Set Tool
 - MP Tool

Note: MBA app source code (for Android and iOS devices) is available to qualified customers upon request. Please contact a local Microchip representative.

3. Supported Devices

DSPKv2.x is supported on several devices as shown in the following table. Modules are pre-programmed with DSPKv1.1 firmware. However, a customer can reprogram with DSPKv2.x firmware as discussed in section [Package Contents](#).

Figure 3-1. Bluetooth Module Details

Bluetooth Module	Description	Firmware Revision
BM62SPKA1MC2-0001AA	BM62, Class 2, No Antenna Shield	DSPK v1.1
BM62SPKS1MC2-0001AA	BM62, Class 2, With Antenna Shield	DSPK v1.1
BM64SPKA1MC2-0001AA	BM64, Class 2, No Antenna Shield	DSPK v1.1
BM64SPKS1MC2-0001AA	BM64, Class 2, With Antenna Shield	DSPK v1.1
BM64SPKA1MC1-0001AA	BM64, Class 1, No Antenna Shield	DSPK v1.1
BM64SPKS1MC1-0001AA	BM64, Class 1, With Antenna Shield	DSPK v1.1
Supporting Hardware		
BM-62-EVB	BM62SPKS1MC2-0001AA	DSPK v1.1
BM-64-EVB-C2	BM64SPKS1MC2-0001AA	DSPK v1.1
BM-64-EVB-C1	BM64SPKS1MC1-0001AA	DSPK v1.1

4. Appendix A: BM62 Customized Parameters

4.1 Customization of UI parameters

Perform the following steps to customize the UI parameters:

1. Open UI tool, *UITool_IS206x_012_DualModeSPK_v2.1.x* from *Tools\UI Tool*. Click **load** to load *UITool_IS206x_012_DualModeSPK_v2.1.6_BM62.txt* from the same folder path, and then click **Open** as shown in the following figure.

Figure 4-1. Loading UI File

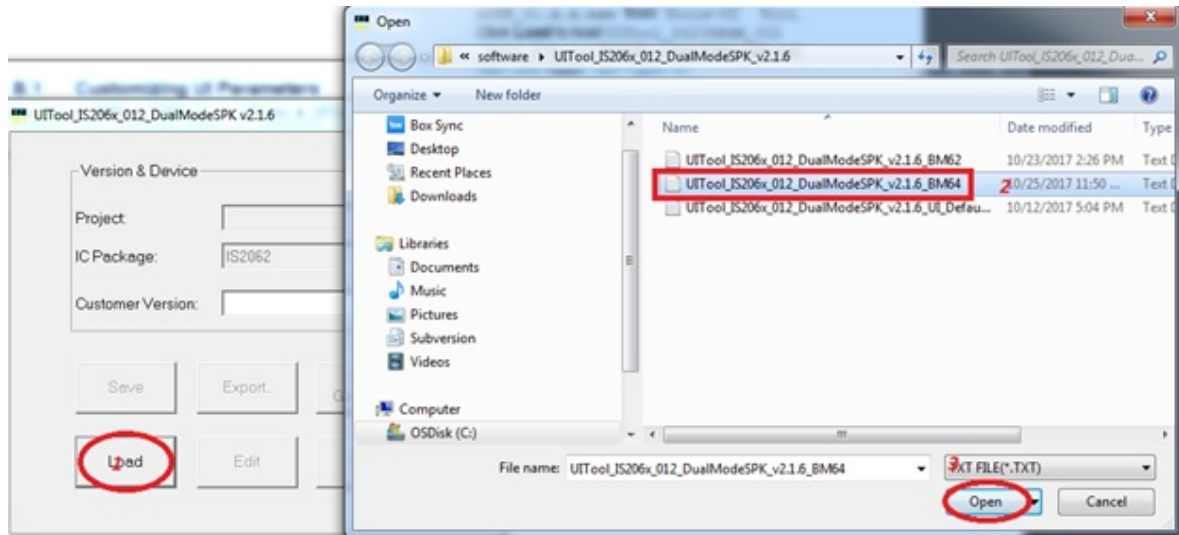

2. From the UI tool, Choose IC package IS2062, and then click **Edit** as shown in the following figure.

Figure 4-2. Edit UI Parameter

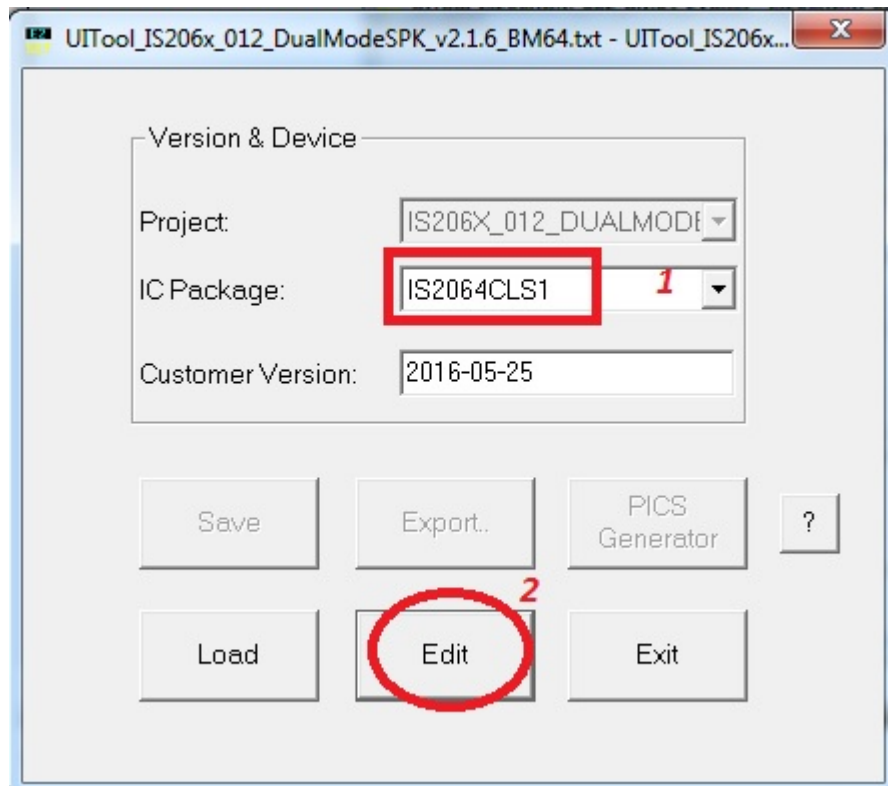

3. A window is displayed as is shown in the following figure. Select profiles, Aux Line In, UART commands, and then click **Next**.

Figure 4-3. Profile Selection

UI Tool_JS206x_012_DualModeSPK_v2.1.6_BM62.txt - UI Tool_JS206x_012_DualModeSPK...

Supported Profile

HFP/HSP A2DP AVRCP SPP iAP
 AVRCP Controller iAP2
 AVRCP Target

Button

Btn0(MFB) Btn1(P0_2) Btn2(P2_7) Btn3(P0_5)
 Btn4(P0_1) Btn5(P0_3)

Function Enable and GPIO Assignment

	P0_0	P0_4	P1_5	P0_3	P2_0	P2_4	P3_7	P3_0	MFB
No Use	<input type="radio"/>	<input checked="" type="radio"/>	<input checked="" type="radio"/>	<input checked="" type="radio"/>	<input checked="" type="radio"/>	<input checked="" type="radio"/>	<input checked="" type="radio"/>	<input type="radio"/>	<input checked="" type="radio"/>
<input type="checkbox"/> Slide Switch	<input type="radio"/>	<input type="radio"/>							
<input type="checkbox"/> NFC Detect	<input type="radio"/>	<input type="radio"/>							
<input type="checkbox"/> Indication1	<input type="radio"/>	<input type="radio"/>							
<input type="checkbox"/> Indication2			<input type="radio"/>						
<input type="checkbox"/> Buzzer			<input type="radio"/>	<input type="radio"/>					
<input type="checkbox"/> CHG/AUX-IN Ind.(LED3)					<input type="radio"/>	<input type="radio"/>			
<input checked="" type="checkbox"/> AUX Line In								<input checked="" type="radio"/>	
<input checked="" type="checkbox"/> UART Command									
<input checked="" type="checkbox"/> Tx IND	<input checked="" type="radio"/>						<input type="radio"/>		<input type="radio"/>
<input type="checkbox"/> Rx IND									<input type="radio"/>
<input type="checkbox"/> CP Reset (iAP)						<input type="radio"/>	<input type="radio"/>		

Cancel **Next**

- Click on **Sys Setup 2** to change the speaker name as shown in the following figure.

Figure 4-4. Changing Speaker Name

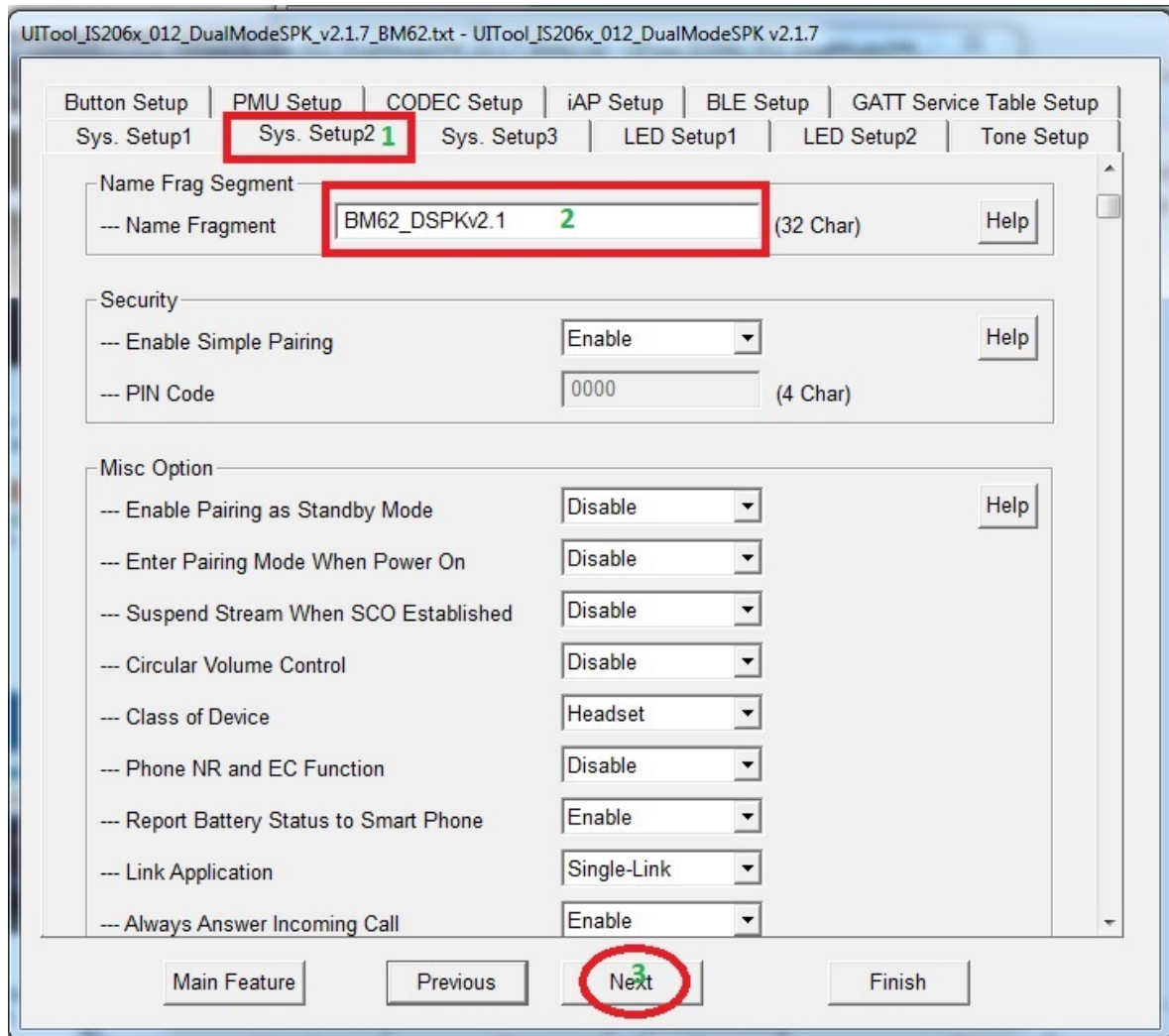

5. Click on **Tone Set** tab, and then assign voice prompts as shown in the following figure, and then click **Finish**.

Figure 4-5. Voice Prompt Enable

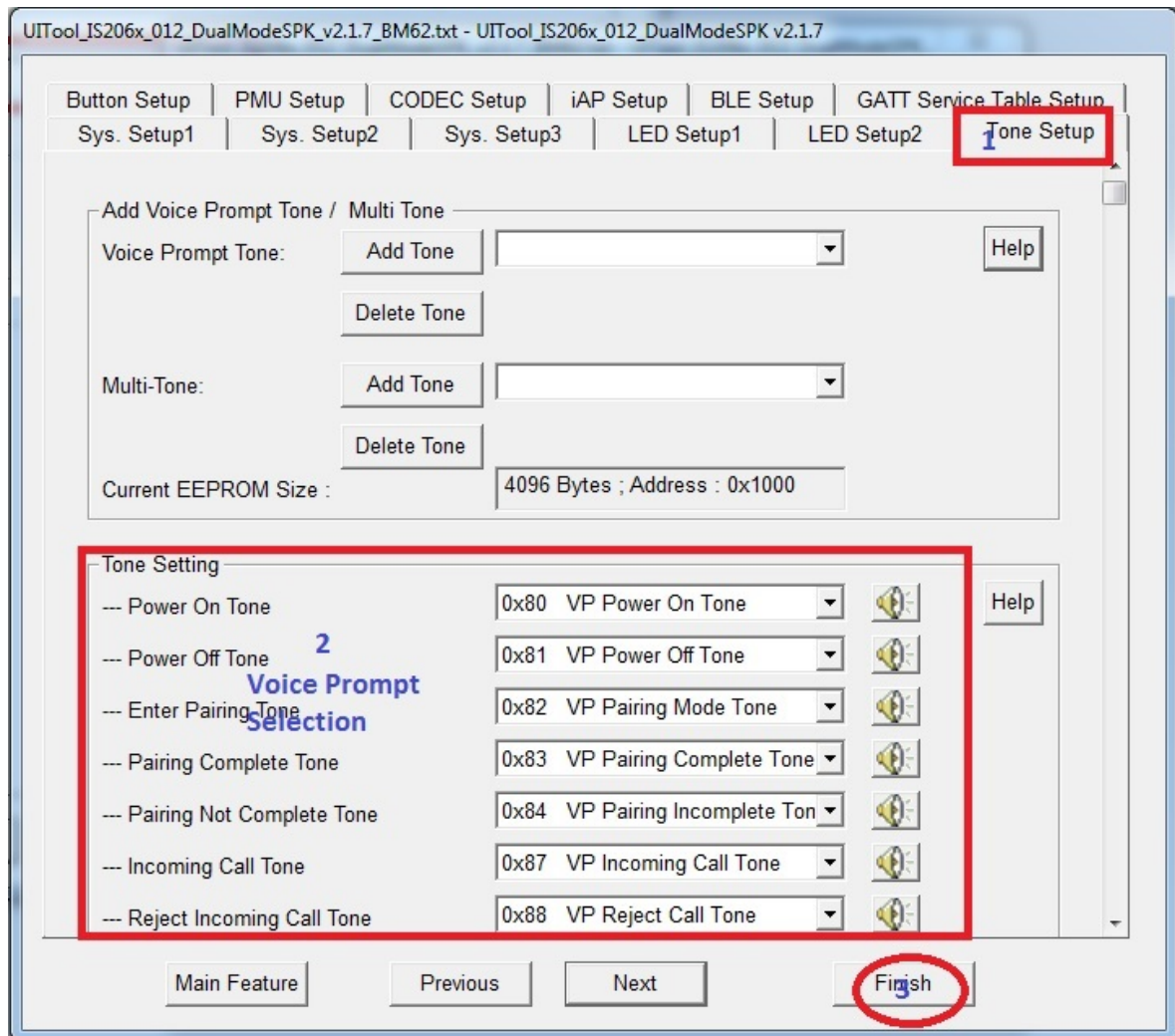

- Click **Exit**, a window is displayed. From the From the Save As window, select the file location, and then click **Save as** shown in the following figure.

Figure 4-6. Saving UI Parameters

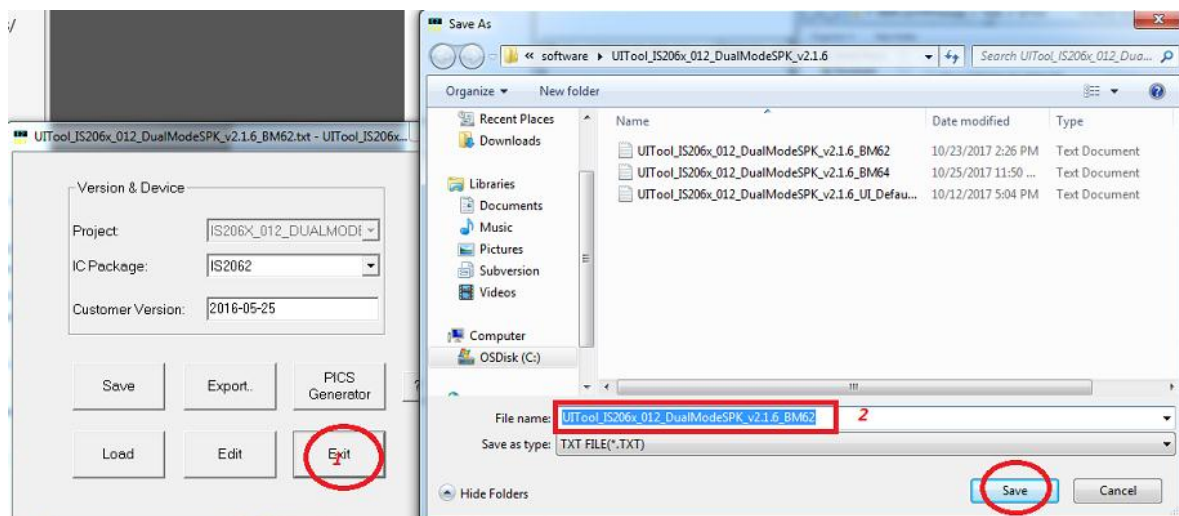

4.2 Customizing DSP Parameters

Perform the following steps to customize the DSP parameters.

1. Open the DSP tool *DSPTool_IS206X_012_DUALMODESPK2.1_E1.0_Vx.exe* from *tools\DSP Tool*. Click *load BM62_DSP.txt* from the same folder as shown in the following figure.

Figure 4-7. Loading DSP Parameters

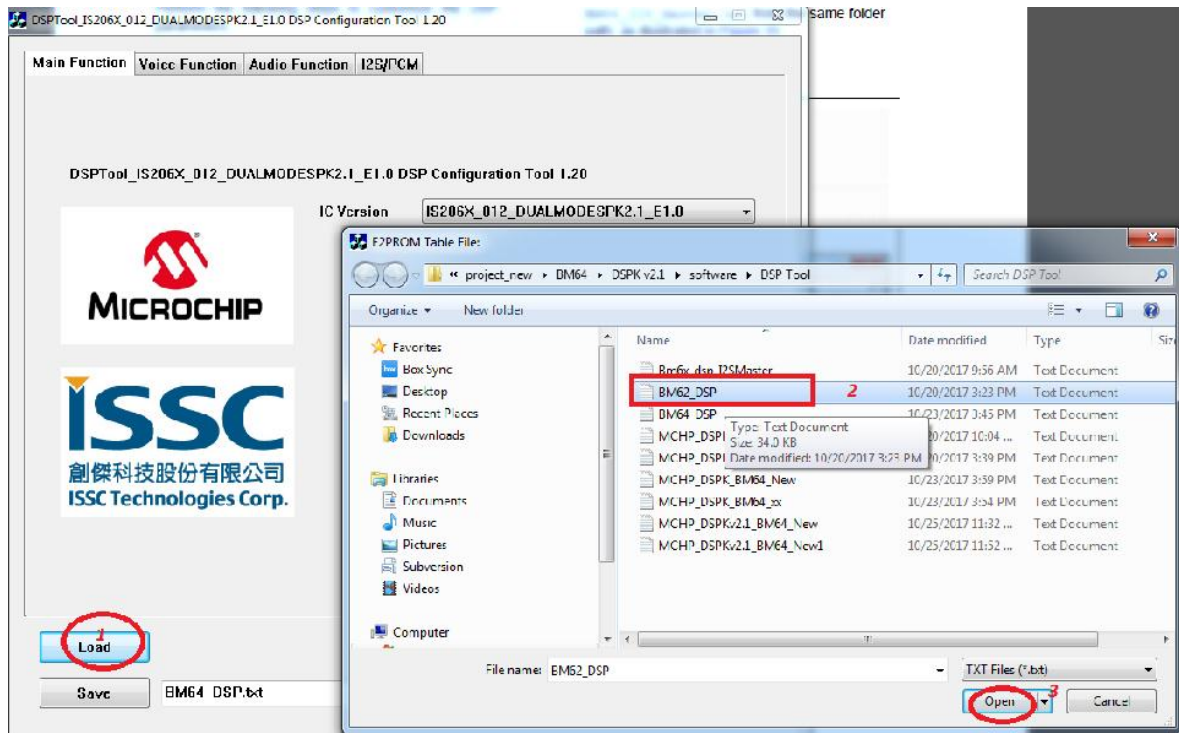

2. Click **Save**, to save the settings as shown in the following figure.

Figure 4-8. DSP Parameter Save

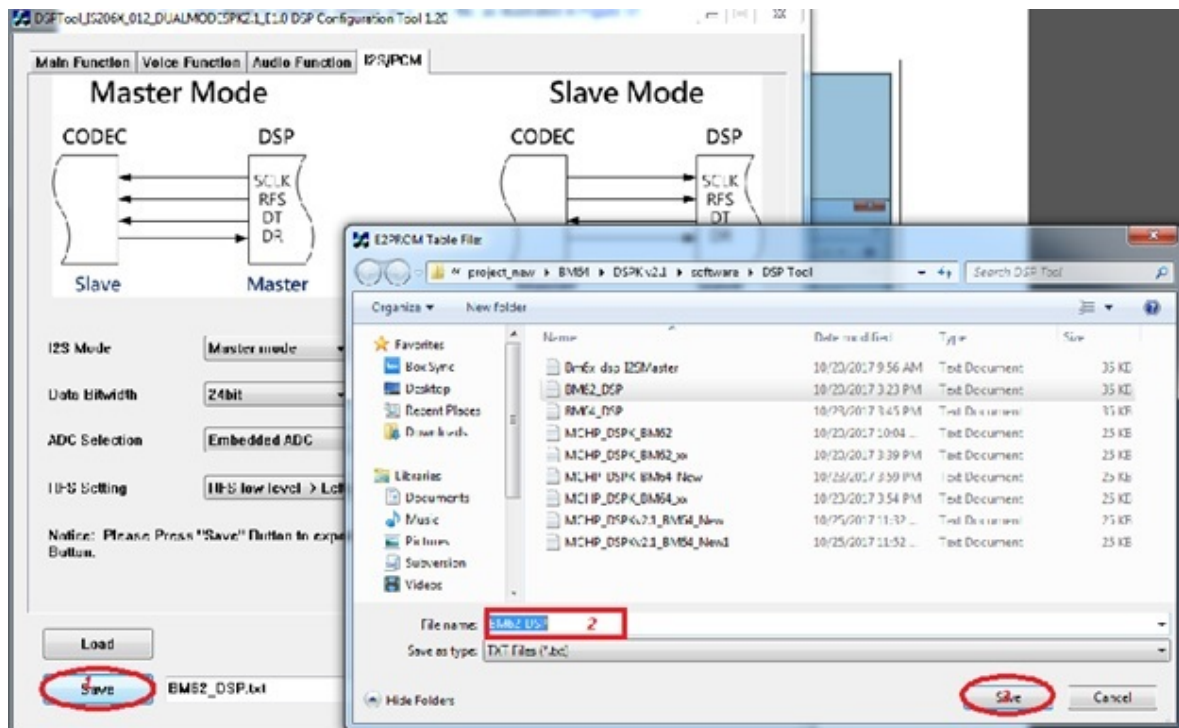

4.3 Creating the *.ipf file

Perform the following steps to create the *.ipf file.

1. Open the MPET tool, MPET.exe from *Tools\MP_Tools_V2.1.xx.xxxx folder*, select UI Patch Only, and then click **Next**, as illustrated in following figure.

Figure 4-9. Selecting Output Format

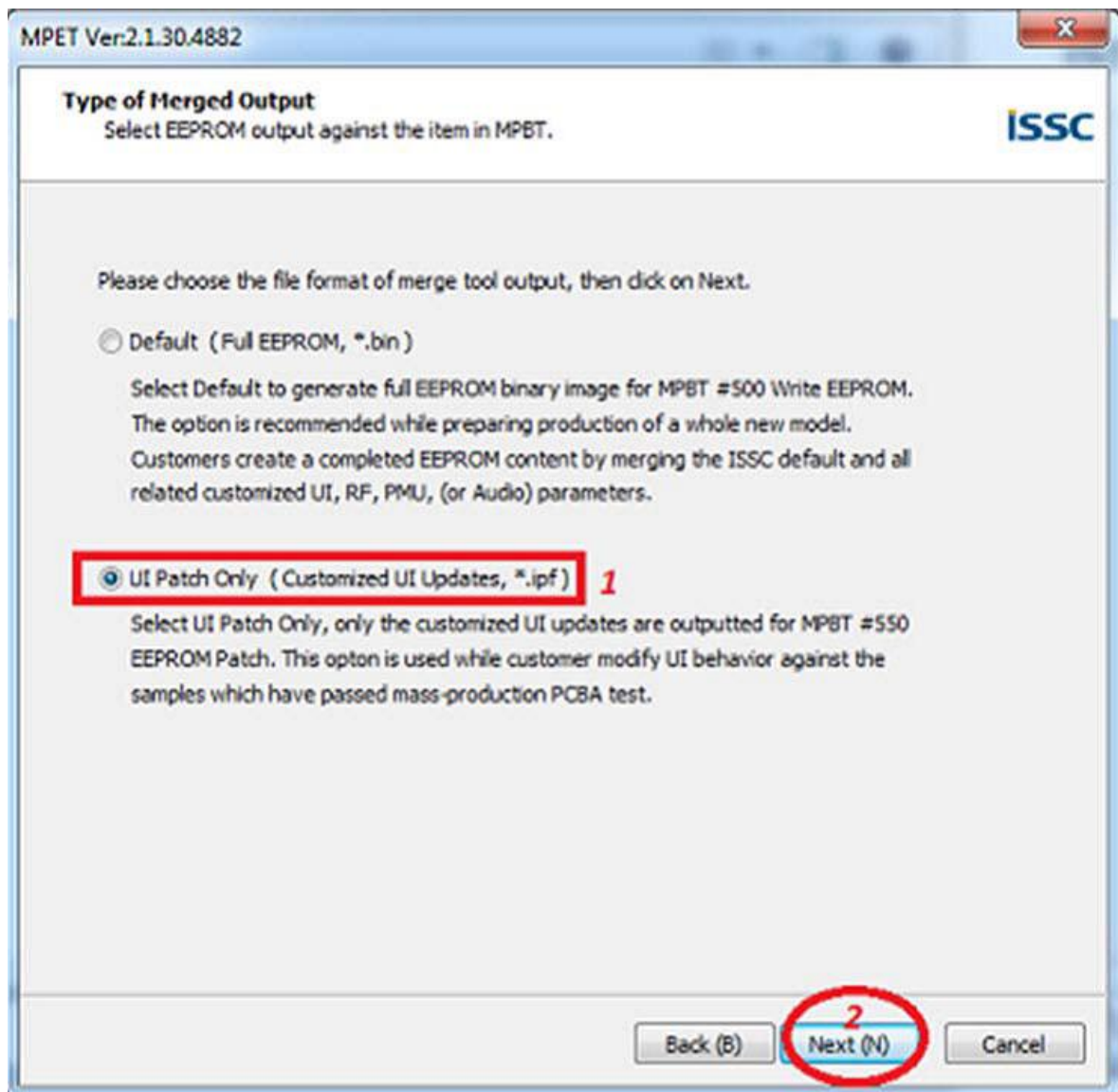

2. Click **Browse** and select `IS206X_012_DUALMODESPK2.1_E1.0.0.x_xxxx` from the `Tools\MP_Tools_V2.1.xx.xxxx\faultfinder` folder. Then click **Open**. The default file will be loaded as shown in the following figure.

Figure 4-10. Loading Default Bin File

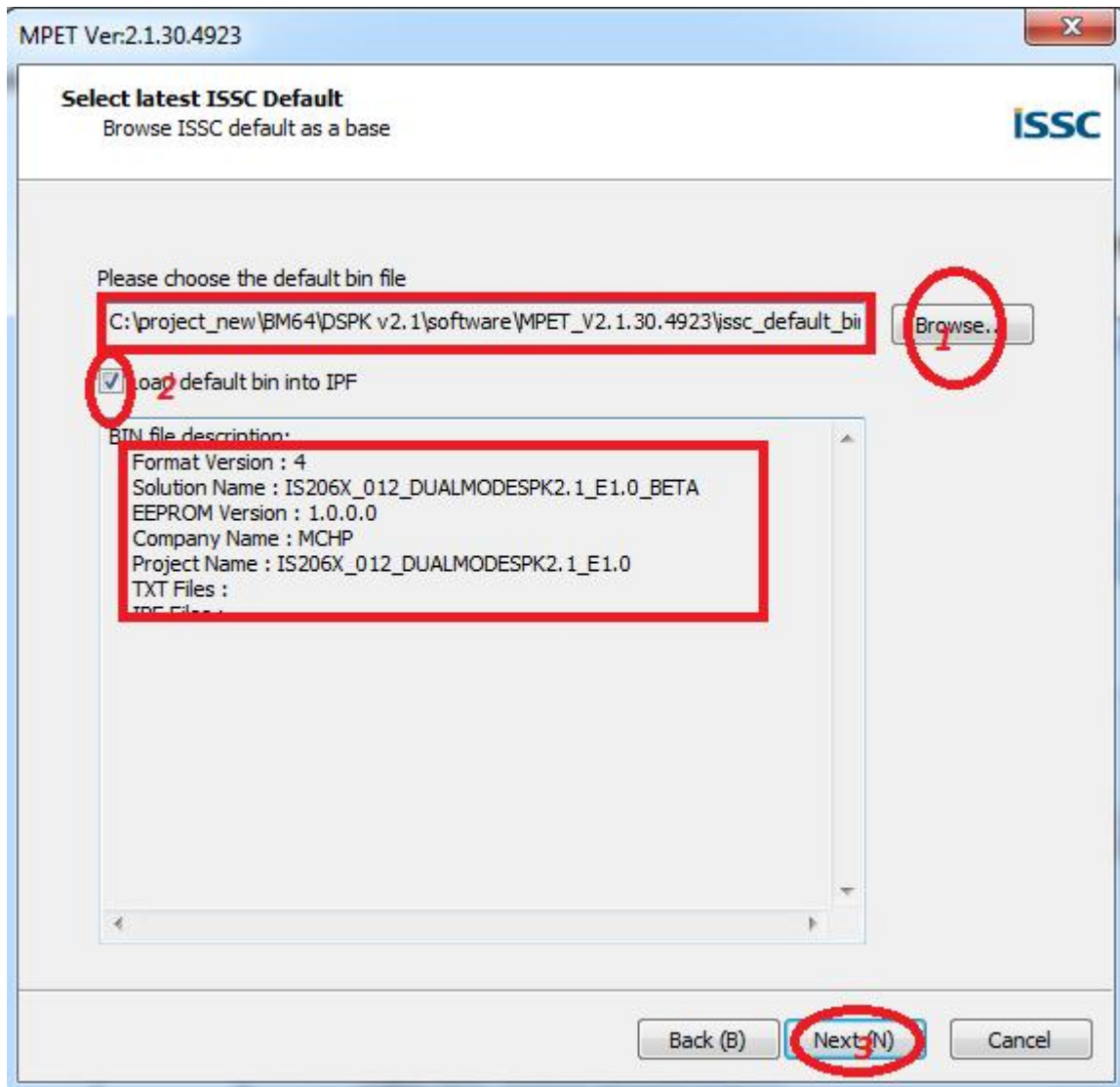

3. Click "+" and select *DSP_BM62.txt* and *UITool_IS206x_012_DualModeSPK_v2.1.6_BM62.txt*, as illustrated in the following figure, and then click **Next**.

Figure 4-11. Loading Customized UI/DSP Parameters

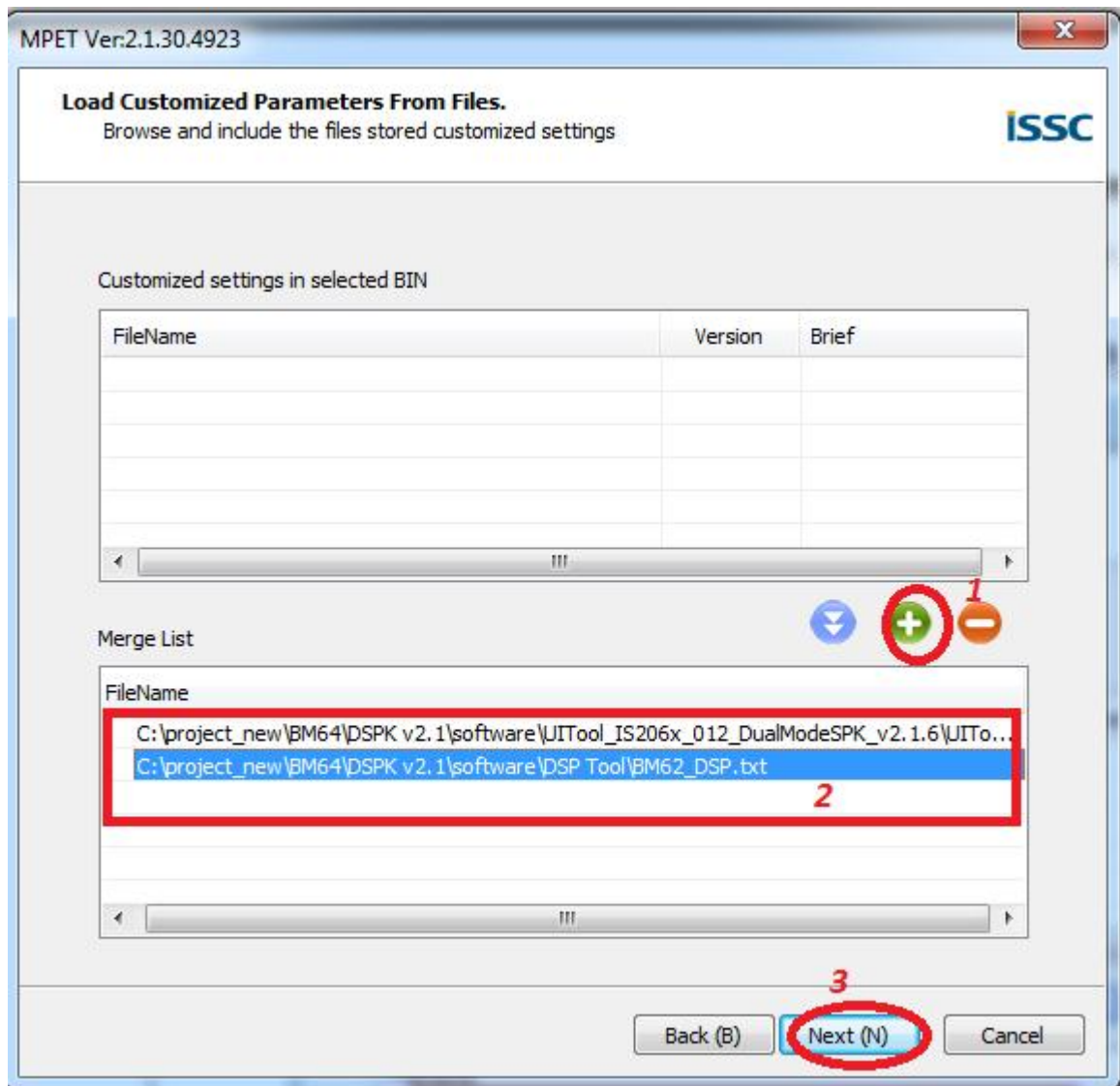

4. Select output file name and path to create *.ipf and then click **Next**, as shown in the following figure.

Figure 4-12. Select Output File

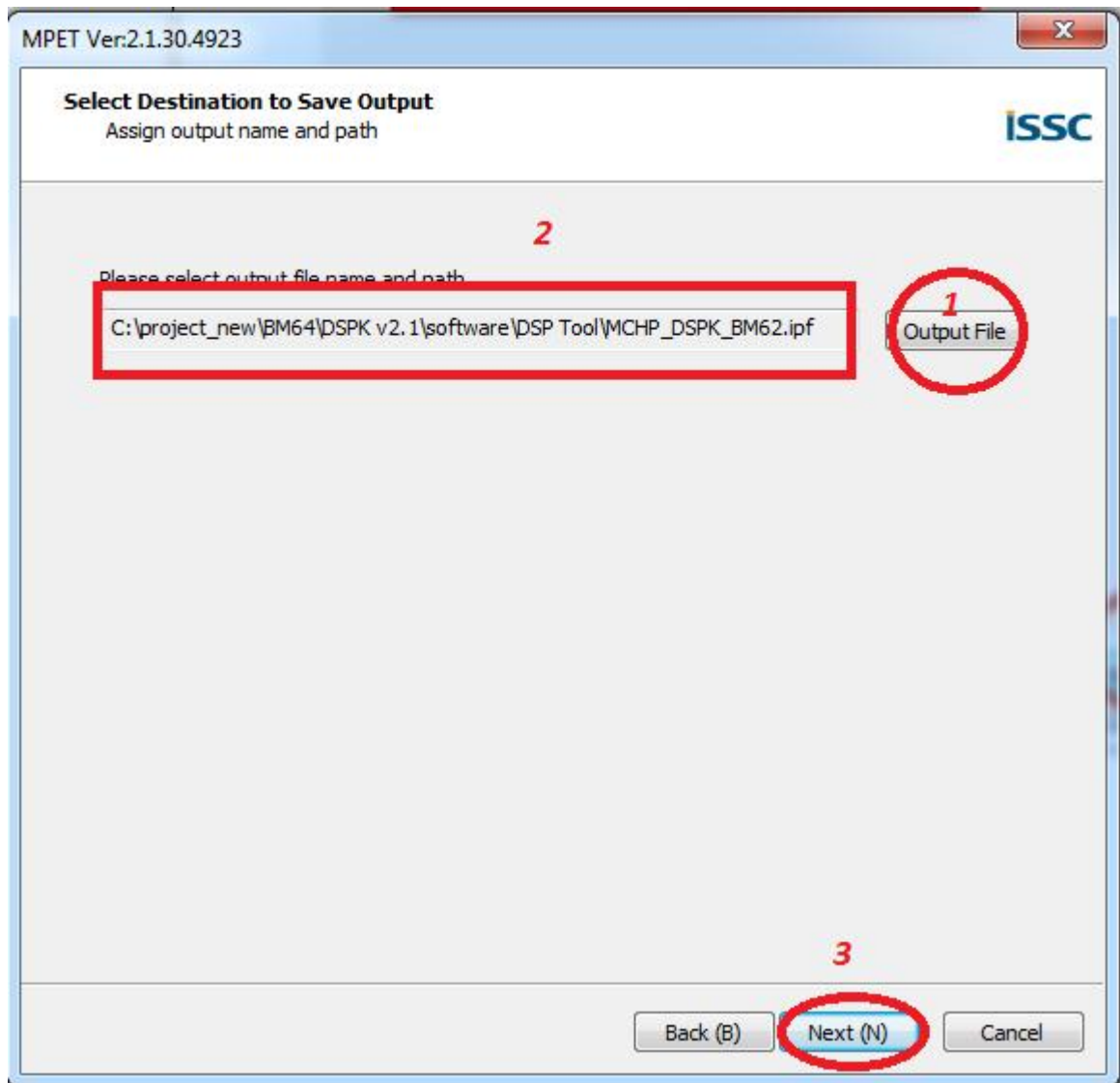

5. Click **Generate** to generate the *.ipf file as shown in the following figure.

Figure 4-13. Generate IPF File

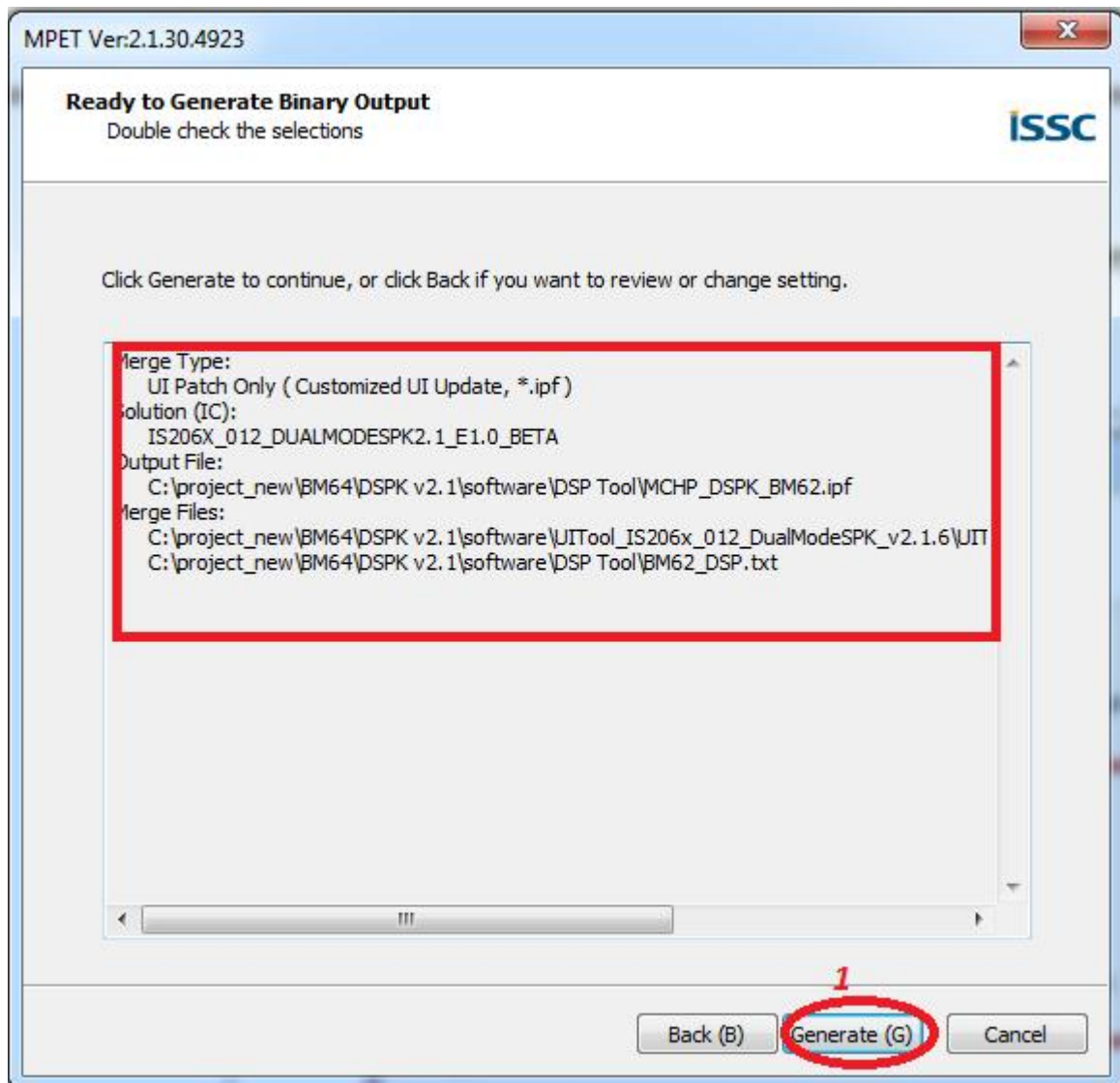

6. Click **Finish** as shown in the following figure. The generated *.ipf can be directly programmed into the BM6x/IS206x device.

Figure 4-14. Completing IPF Generation



5. Appendix B: BM64 Customized Parameters

5.1 Customization of UI Parameters

Perform the following steps to customize the UI parameters:

1. Open the UI tool, *UITool_IS206x_012_DualModeSPK_v2.1.x.exe* from *Tools\UI Tool*. Click **Load** to load *UITool_IS206x_012_DualModeSPK_v2.1.6_BM64.txt* from the same folder path and then click **Open**, as shown in the following figure.

Figure 5-1. Loading UI Tools and Default UI Parameters

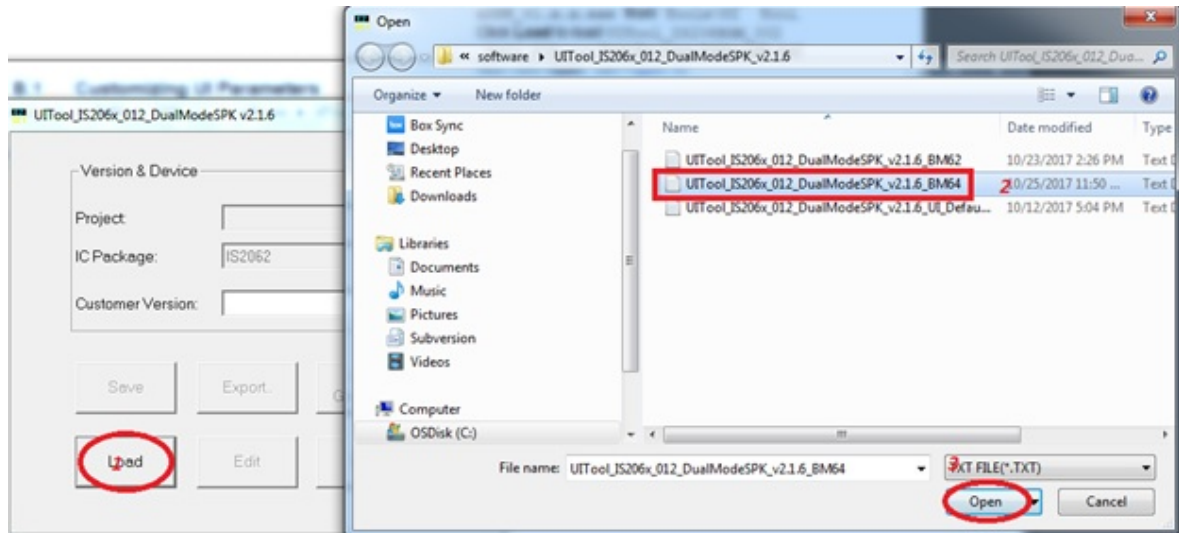

2. From the UI Tool, click **Edit** as shown in the following figure.

Figure 5-2. Edit UI Parameters

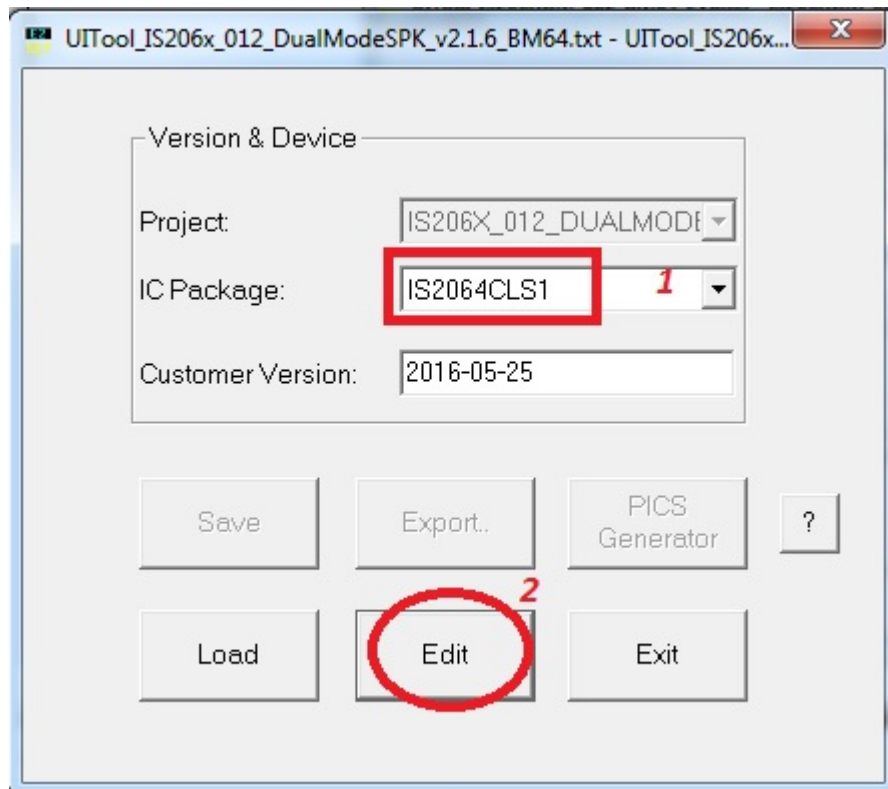

3. A window is displayed. Select profiles, Aux Line In, UART Command, and then click **Next** as shown in the following figure.

Figure 5-3. Main Features Settings

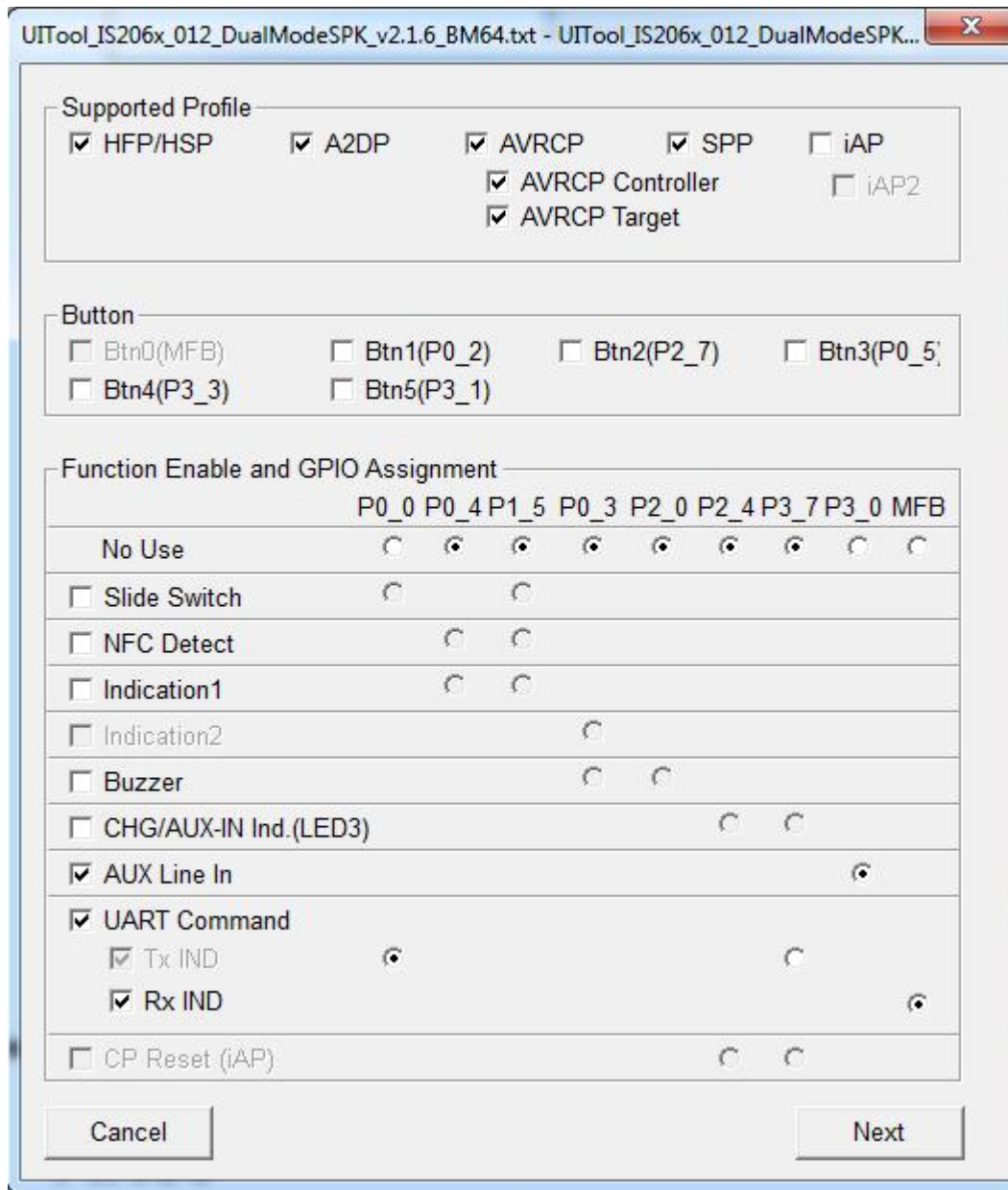

4. Select Uart CMD Power on as shown in the following figure.

Figure 5-4. UART Command Settings

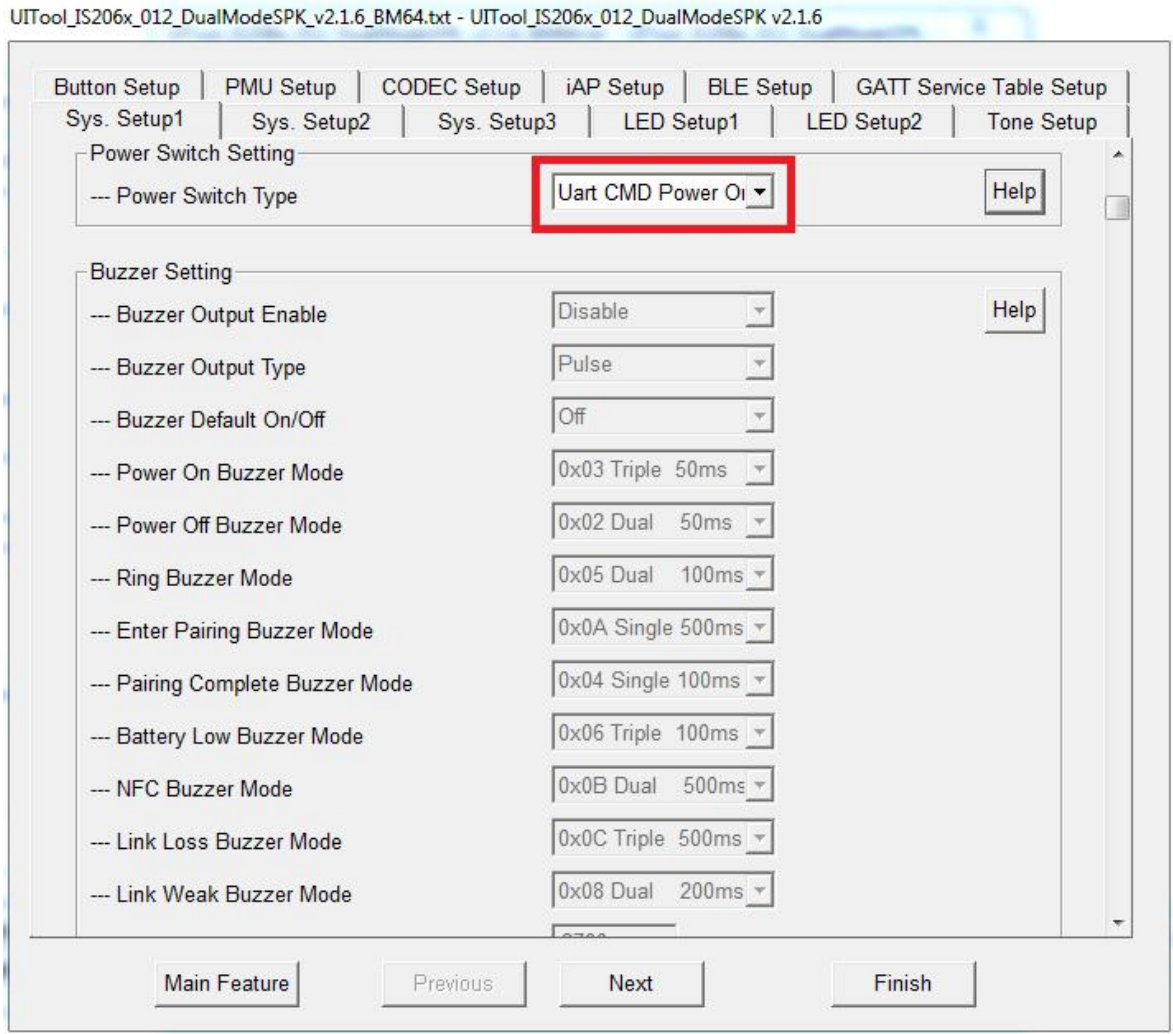

5. Click **Sys Setup2** tab to change the speaker name as shown in the following figure.

Figure 5-5. Enable External Amplifier Indication

UITool_IS206x_012_DualModeSPK_v2.1.6_BM64.txt - UITool_IS206x_012_DualModeSPK v2.1.6

Button Setup | PMU Setup | CODEC Setup | iAP Setup | BLE Setup | GATT Service Table Setup
Sys. Setup1 | **Sys. Setup2** 1 | Sys. Setup3 | LED Setup1 | LED Setup2 | Tone Setup

Name Frag Segment
-- Name Fragment **BM64_DSPKV2.1** 2 (32 Char) Help

Security
-- Enable Simple Pairing Enable Help
-- PIN Code 0000 (4 Char)

Misc Option
-- Enable Pairing as Standby Mode Disable Help
-- Enter Pairing Mode When Power On Disable
-- Suspend Stream When SCO Established Disable
-- Circular Volume Control Disable
-- Class of Device Headset
-- Phone NR and EC Function Disable
-- Report Battery Status to Smart Phone Enable
-- Link Application Multi-Link
-- Always Answer Incoming Call Enable

Main Feature Previous **Next** 3 Finish

6. Click on **Tone Setup** tab, and then assign Voice prompts as shown in the following figure.

Figure 5-6. Tone Setup Settings

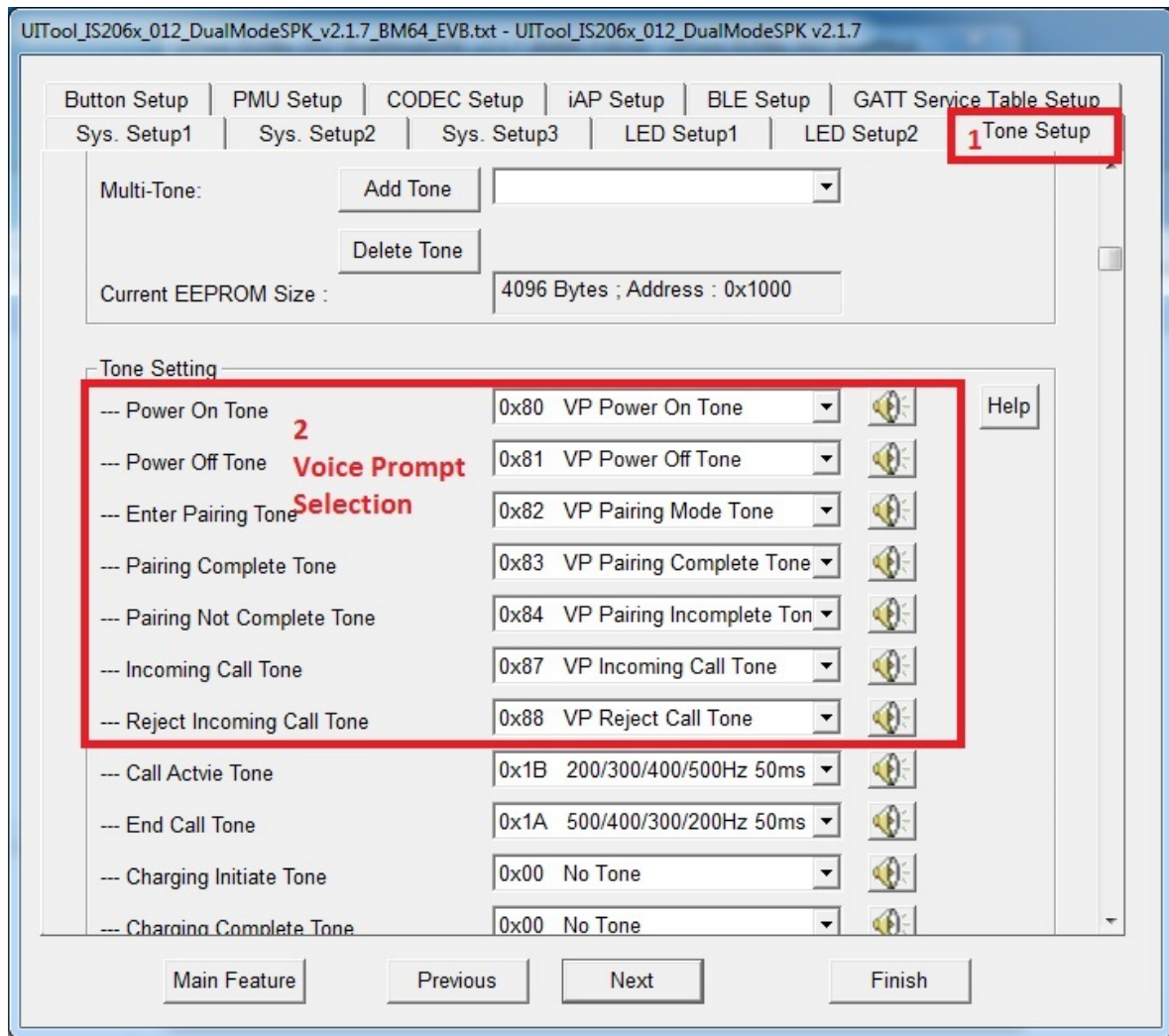

7. Click on **CODEC Setup** tab, and then select External Codec, Audio SRC, Voice SRC, Voice Stereo, Tone Stereo as shown in the following figure.
 - 7.1. External Codec:
 - External Codec – audio is routed to I2S
 - Internal Codec – audio is routed to SPK
 - 7.2. Audio SRC:
 - Enable – 44.1K->48K SRC, audio @48kHz
 - Disable – No SRC, audio @sampling rate (as per the sound source sampling rate)
 - 7.3. Voice SRC:
 - Enable – 8/16K->48K SRC, HFP Call@48kHz
 - Disable – No SRC. HFP call @8/16kHz
 - 7.4. Voice Stereo:
 - Enable – HFP will be heard on both L and R channel
 - Disable – HFP will be heard on one channel
 - 7.5. Tone Stereo:
 - Enable – Tone/Voice Prompt is heard on both L and R Channel
 - Disable – Tone/Voice Prompt is heard on one channel

Figure 5-7. CODEC Setup Settings

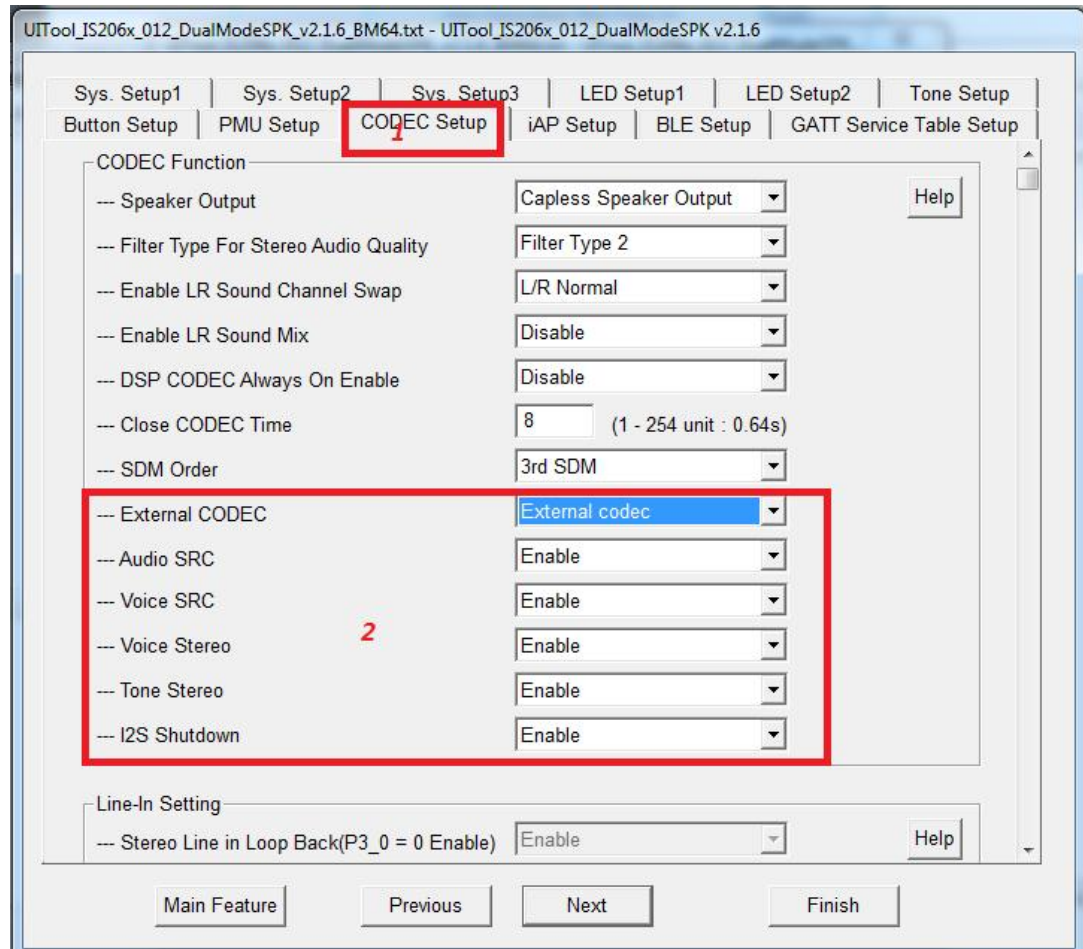

8. Click on **BLE Setup** tab, and then change the BLE Device name as shown in the following figure, and then click **finish**.

Figure 5-8. BLE Name Change

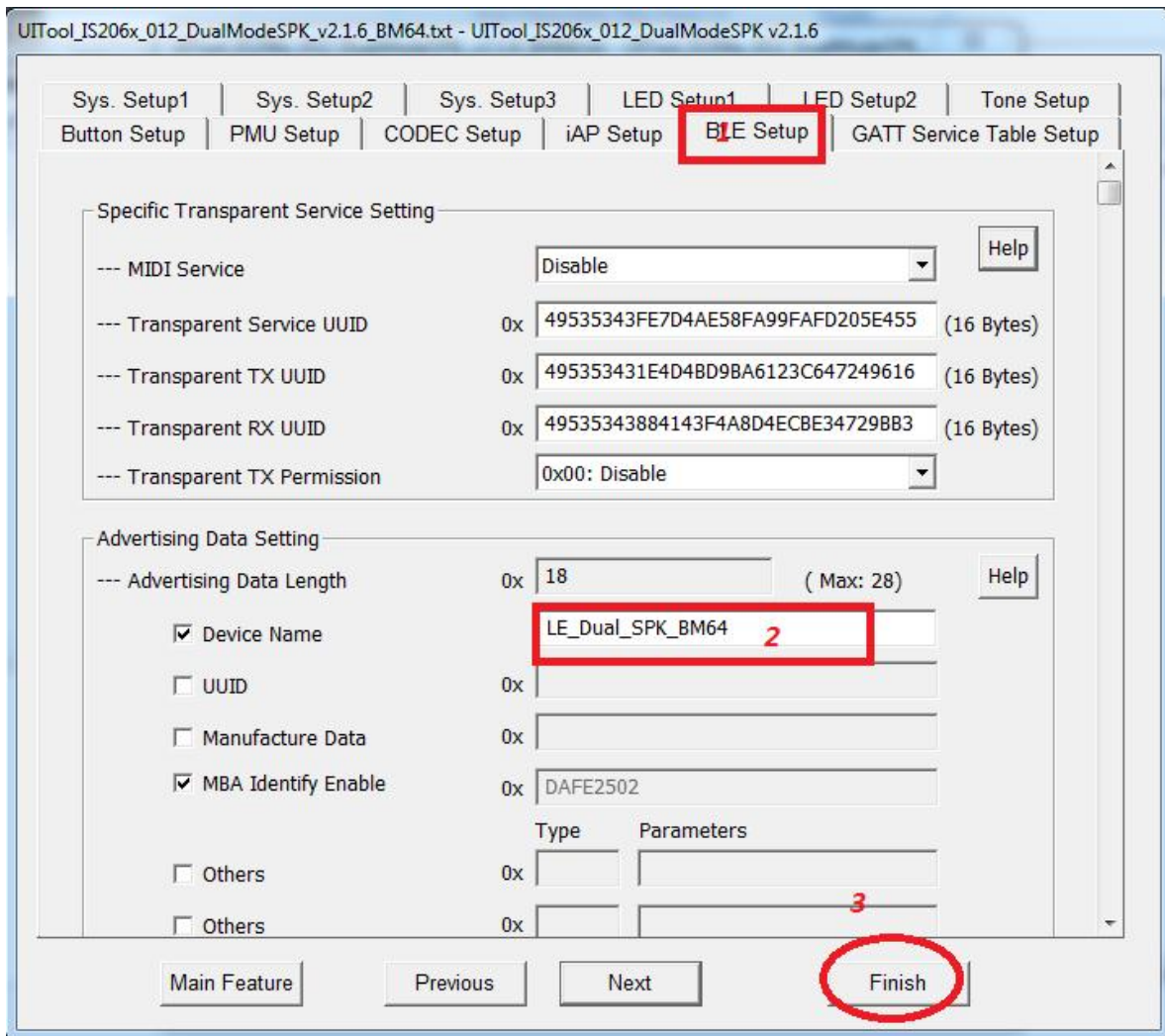

- Click **Exit**, a window is displayed. From the Save As Window, select the file location and click **Save as** shown in the following figure.

Figure 5-9. Saving Parameters

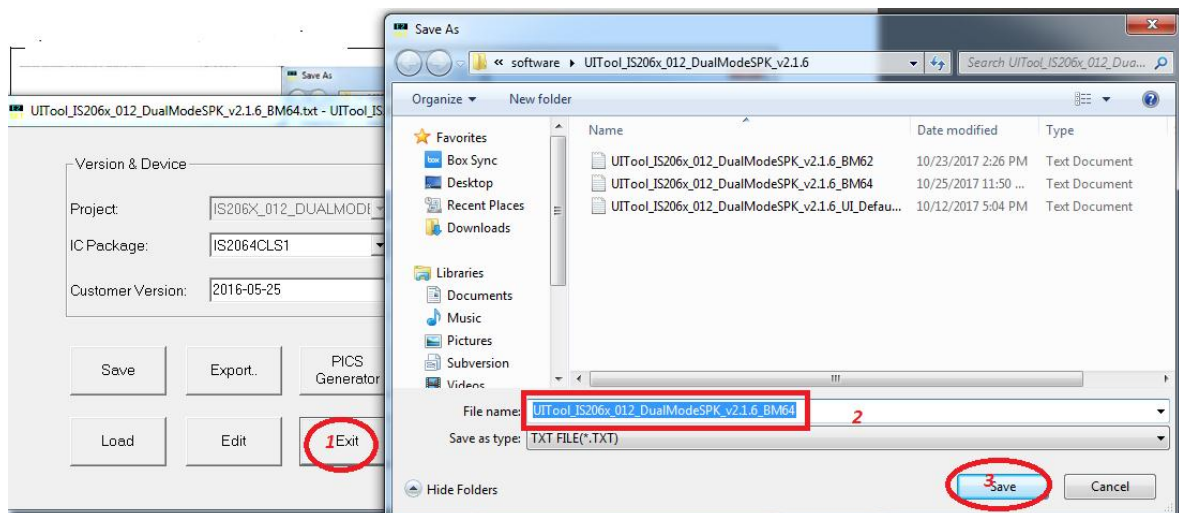

5.2 Customization of the DSP Parameters

Perform the following steps to customize the DSP parameters:

1. Open the DSP Tool, *DSPTool_IS206X_012_DUALMODESPK2.1_E1.x_V2.exe* from *tools\DSP Tool*. Click **Load** to load *DSPK_BM64_I2S_Master.txt* from the same folder path, as illustrated in the following figure.

Figure 5-10. DSP Tool Settings

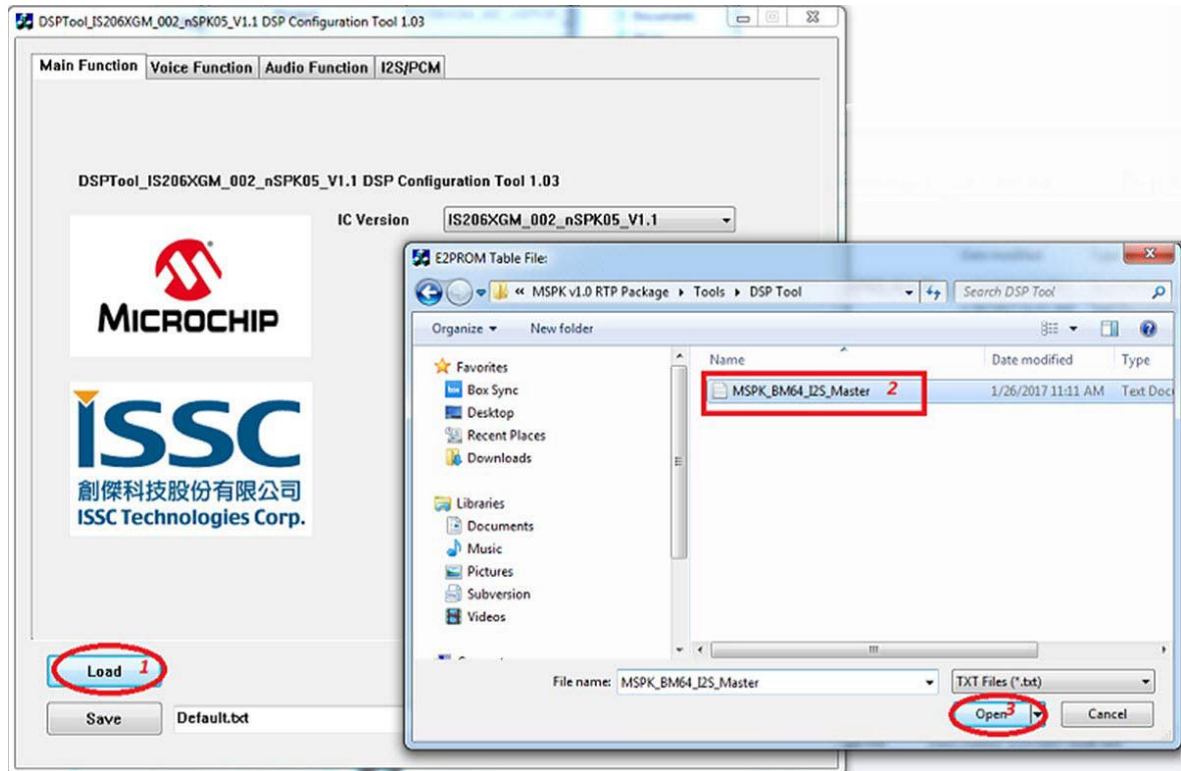

2. Click the **I2S/PCM** tab and perform I2S related selections, as illustrated in the following figure.

Figure 5-11. I2S Master Mode Settings

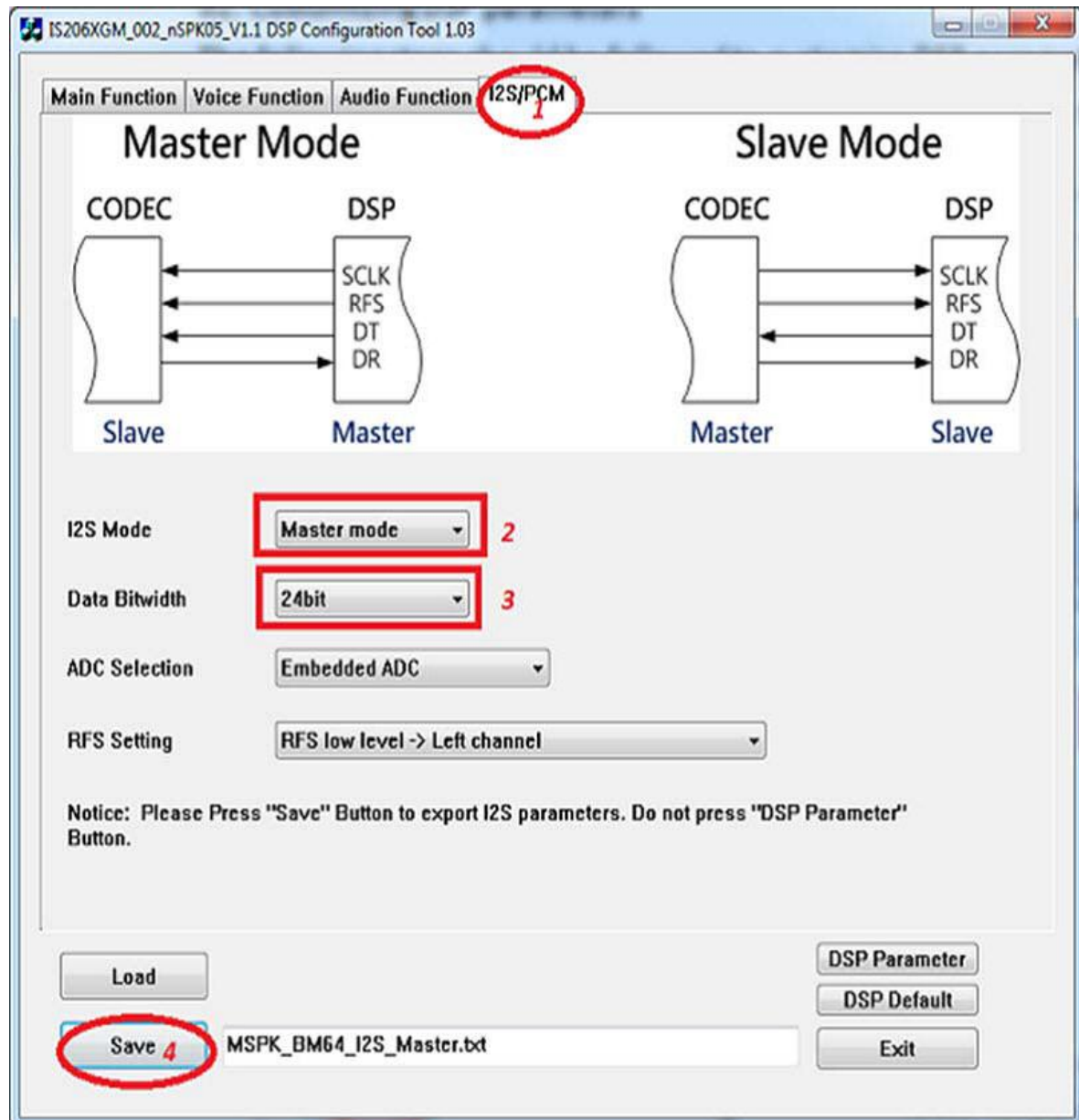

3. Click **Save** to save the settings as a .txt file, as illustrated in the following figure.

Figure 5-12. DSP Parameter Save

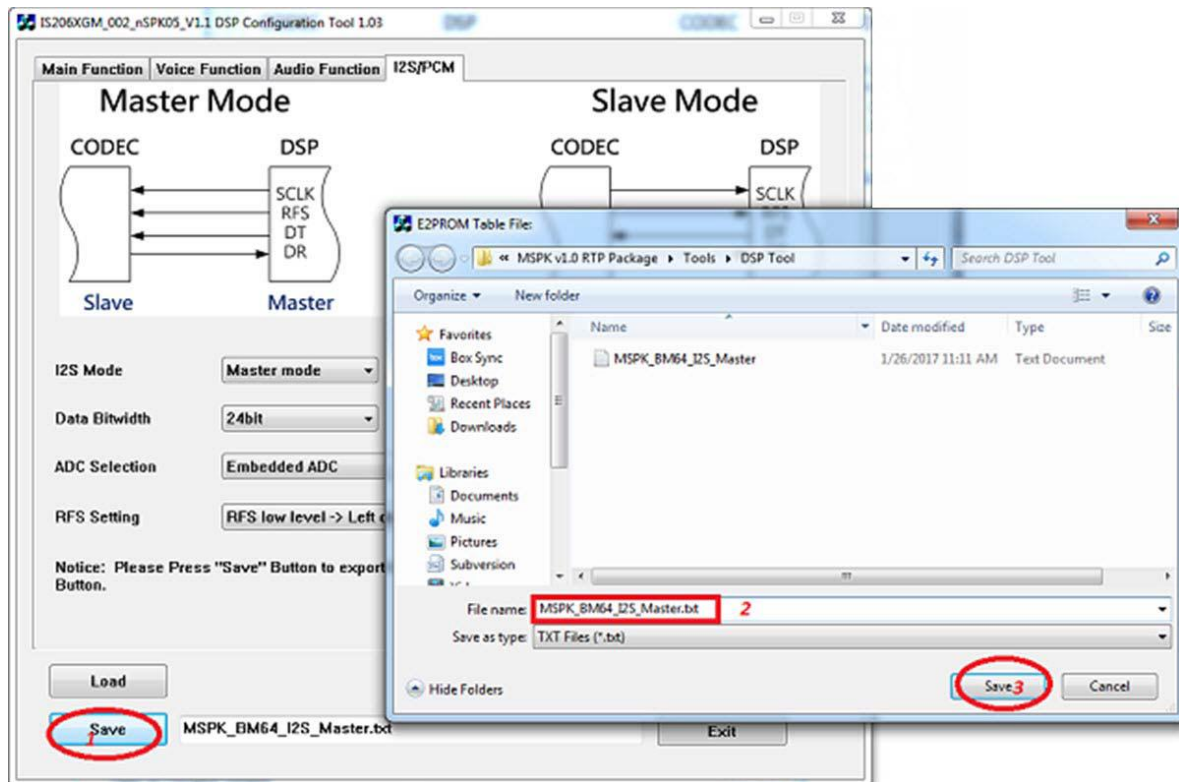

5.3 Creating *.ipf file

Refer to [Appendix C](#).

6. Appendix C: BM64 I2S Master/Slave Mode

BM64 I2S can be configured into I2S master and I2S slave mode. [Appendix B](#) describes BM64 configured into I2S master mode. This section describes BM64 configured into I2S slave mode.

6.1 Selecting UI Parameters

Perform all the steps from [5. Appendix B: BM64 Customized Parameters](#). The only difference is enabling Audio SRC and Voice SRC, as illustrated in the following figure. Click the **CODEC Setup** tab, enable Audio SRC, Voice SRC, and then select “External CODEC” as **External codec**. The voice prompt and HFP can be enabled in stereo mode.

Figure 6-1. Codec Parameter Settings

The screenshot shows the 'CODEC Setup' tab with the following settings:

Setting	Value
Speaker Output	Capless Speaker Output
Filter Type For Stereo Audio Quality	Filter Type 2
Enable LR Sound Channel Swap	L/R Normal
Enable LR Sound Mix	Disable
DSP CODEC Always On Enable	Disable
Close CODEC Time	8 (1 - 254 unit : 0.64s)
SDM Order	3rd SDM
External CODEC	External codec
Audio SRC	Enable
Voice SRC	Enable
Voice Stereo	Enable
Tone Stereo	Enable
I2S Shutdown	Disable

The 'Line-In Setting' section is also visible:

Setting	Value
Stereo Line in Loop Back(P3_0 = 0 Enable)	Enable

Note: If “External CODEC” is selected as “internal codec” then audio will be routed to analog speaker out.

Note: For BM64 I2S Master mode at 48 kHz, refer to [5. Appendix B: BM64 Customized Parameters](#).

6.2 Selecting DSP Parameters

Perform all the steps from [Appendix B](#). The only difference is to select I2S mode as Slave mode, as illustrated in the following figure.

Figure 6-2. I2S Slave

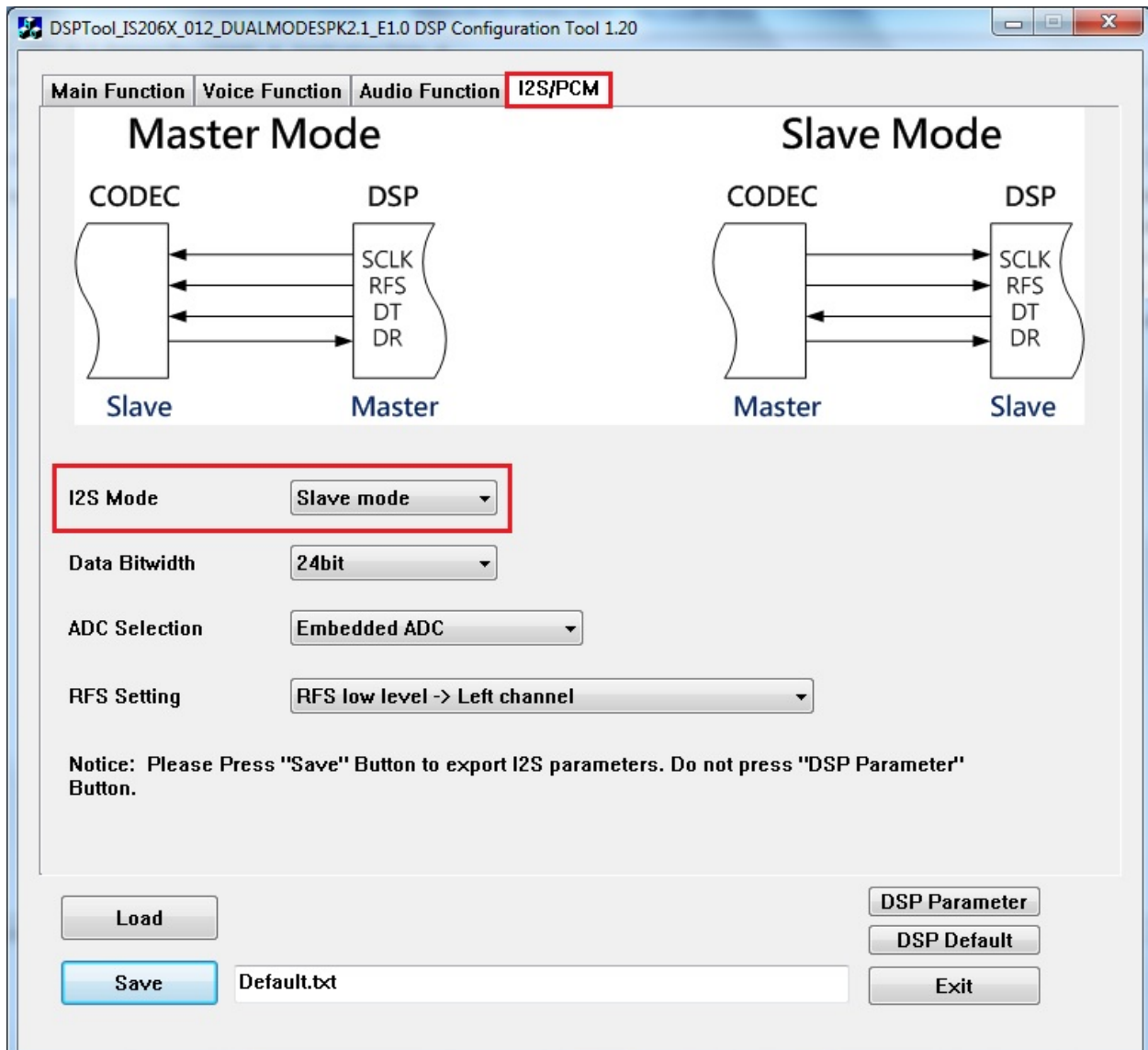

6.3 Creating *.ipf file

Refer to [Appendix C](#).

7. Appendix D: BLE Status in Power Off Mode

UI tool has provided an option to disconnect BLE while entering into pairing mode. Please select disable this feature as shown in the following figure.

Figure 7-1. Disable BLE During Pairing

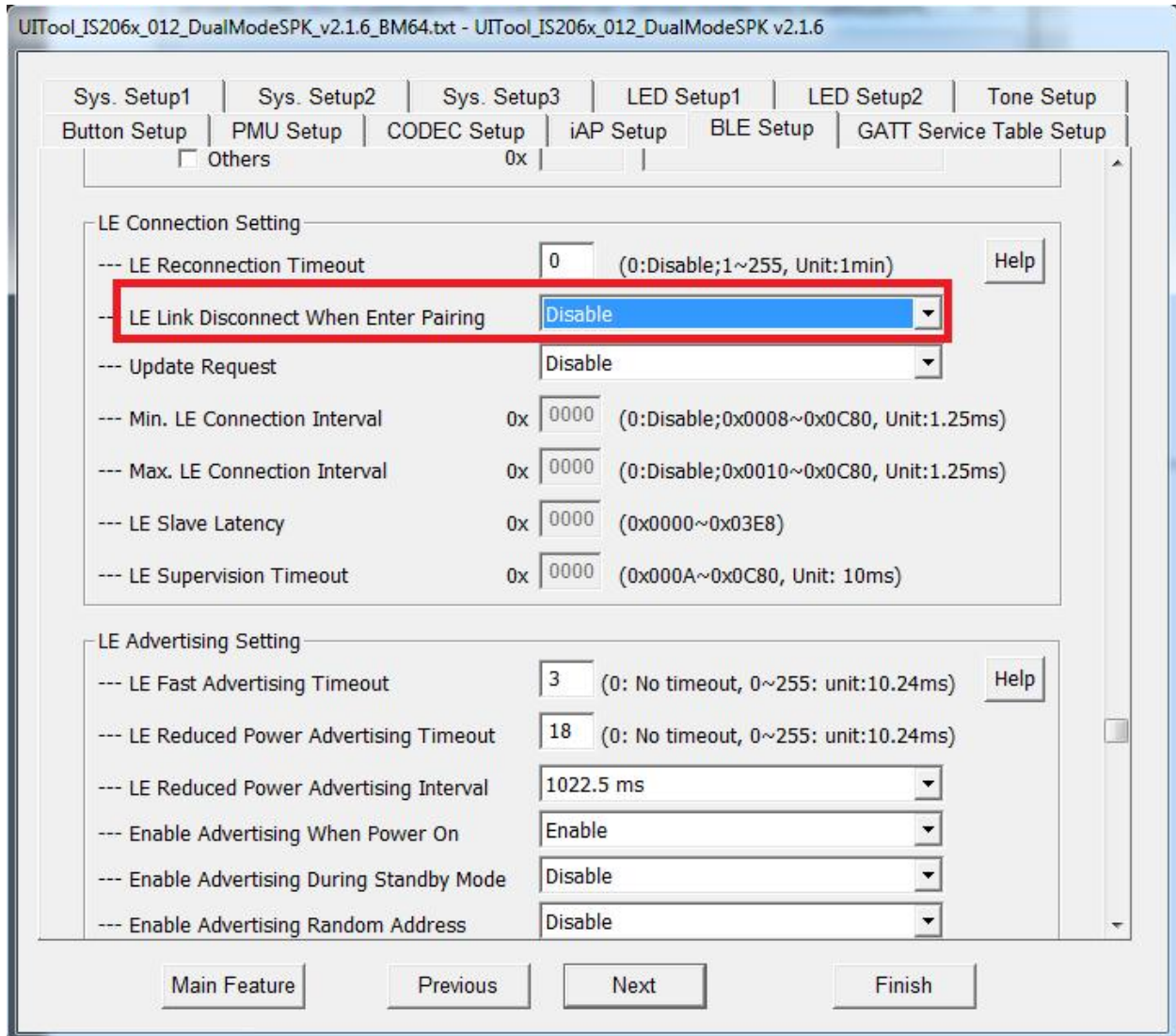

8. Appendix E: BLE Configuration-Power Off

BLE can be turned on/off when the BM6x device is powered off. Having BLE on when the BM6x device is powered off is useful when using the MBA app to power on the BM6x. Please choose enable/disable as shown in the following figure.

Figure 8-1. BLE Disable During BM6X OFF State

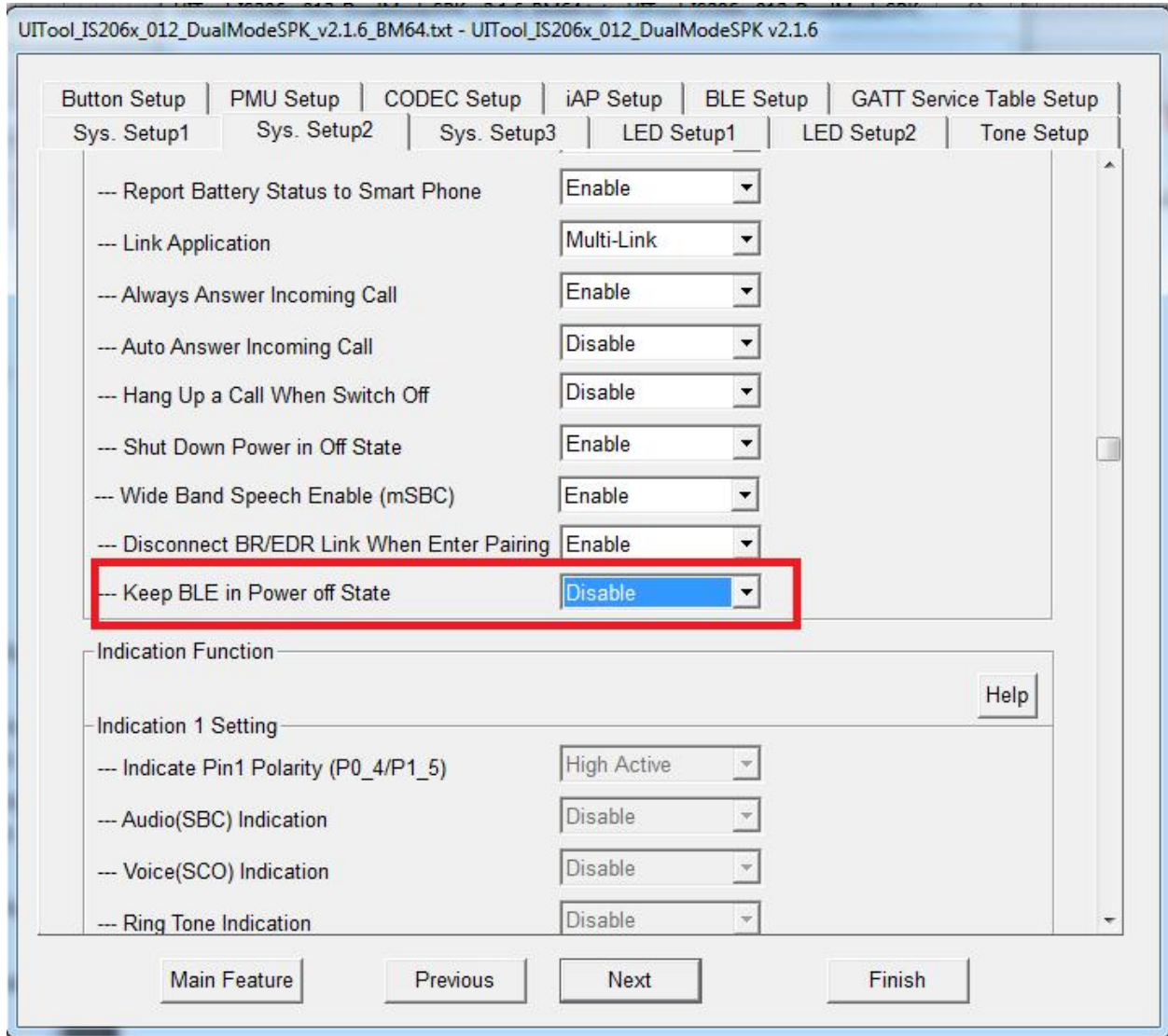

9. Appendix F: MBA Power Mode

The Microchip Bluetooth audio app can also be used for power on/off for individual BM64 speaker touch power to turn on/off the BM64 speaker, as illustrated in the following figure. This is similar to the short press of MFB on the BM64 EVB.

Figure 9-1. ON/OFF Through MBA

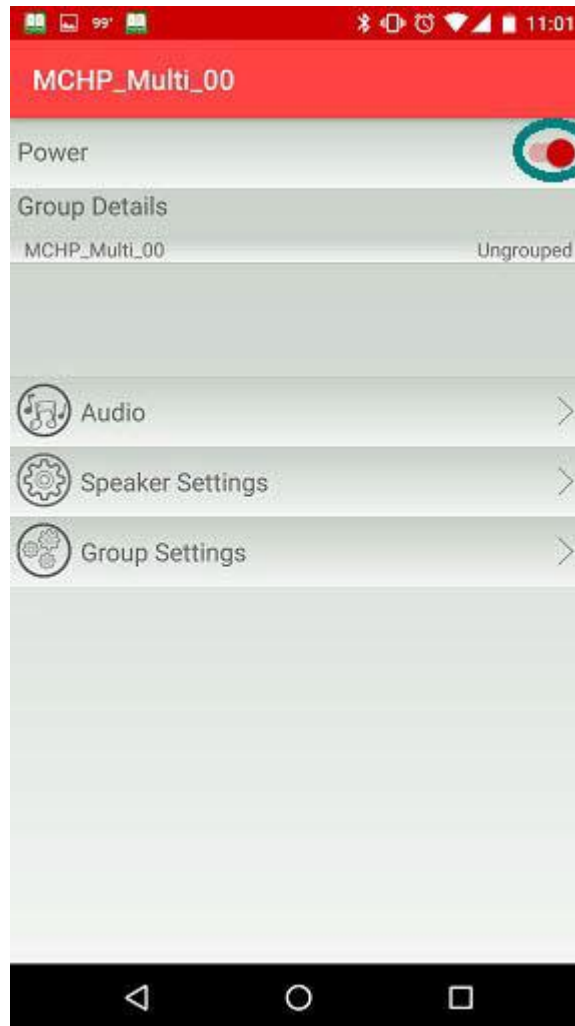

10. Appendix G: Customized Voice Prompt

A customized voice prompt can be added as shown in the following figure.

Figure 10-1. Adding Customized Voice Prompt

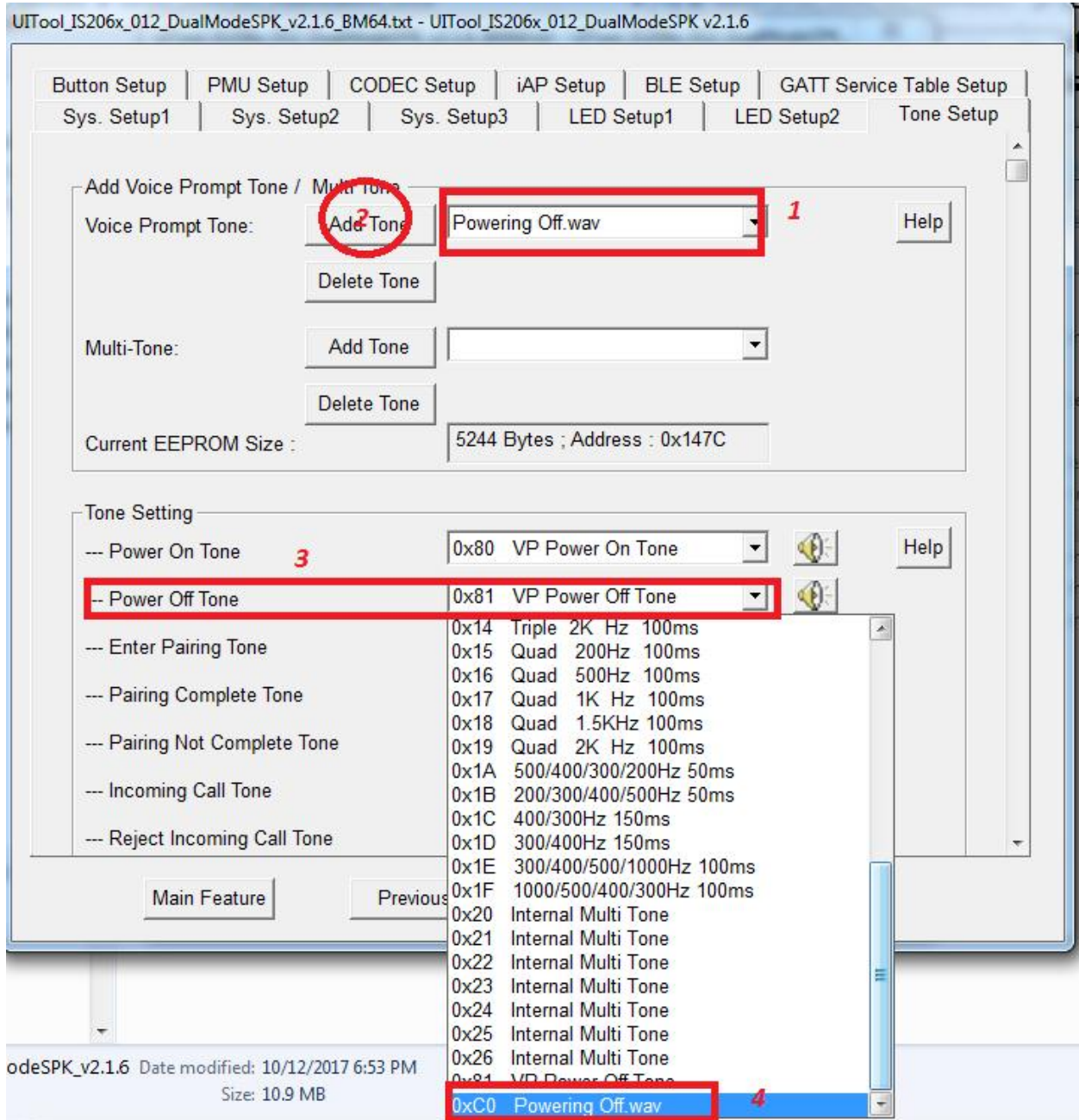

11. Appendix H: Enabling UART in BM62

UART can be enabled in the UI tool of BM62 as shown in the following figure. *SPKCommandSetTool* can be used to control BM62.

Figure 11-1. Enabling UART

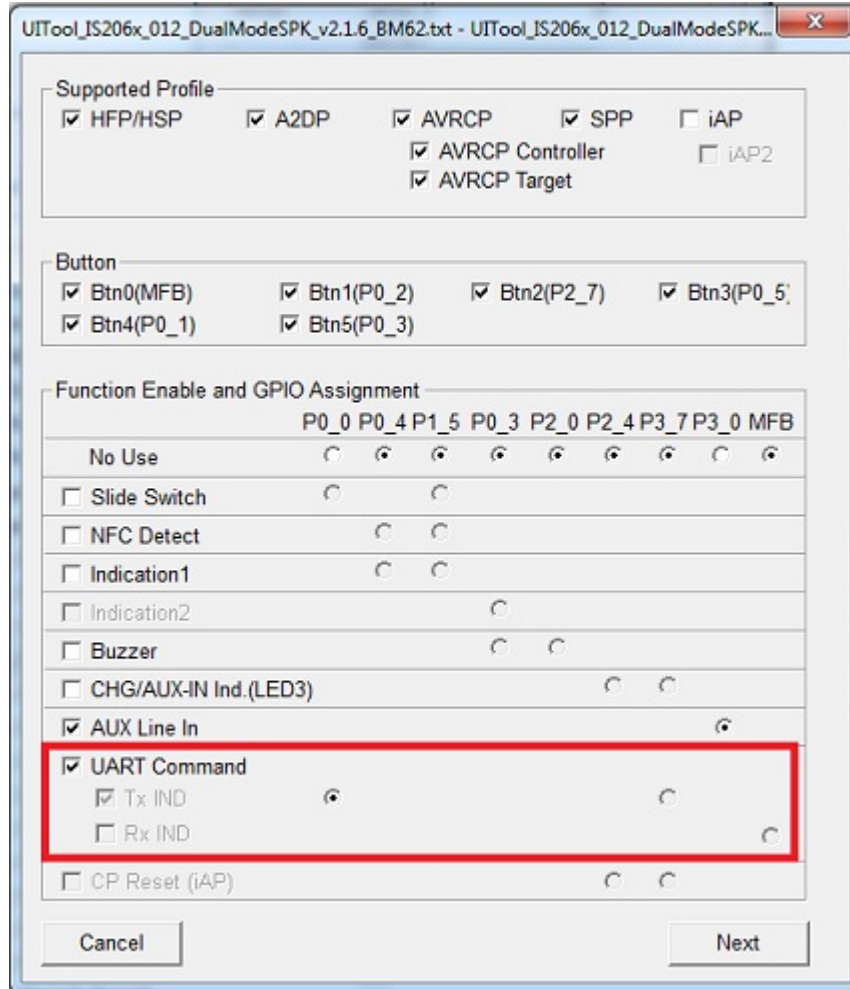

12. Appendix I: MBA Application Installation

Install the Microchip Bluetooth Audio (MBA) application on an Android 6.0 and higher device. The iOS version of the MBA application is available in the Apple iTunes store. It is similar to the Android version of the application. To install the application, perform the following steps:

1. Connect the Android phone to the computer using a mini-B USB connector.
Note: The latest Android version (Android 6.0 and higher) does not show any directory in the phone. Enable “transfer files” from the phone to access phone memory, as illustrated in the following figure.

Figure 12-1. USB Transfer

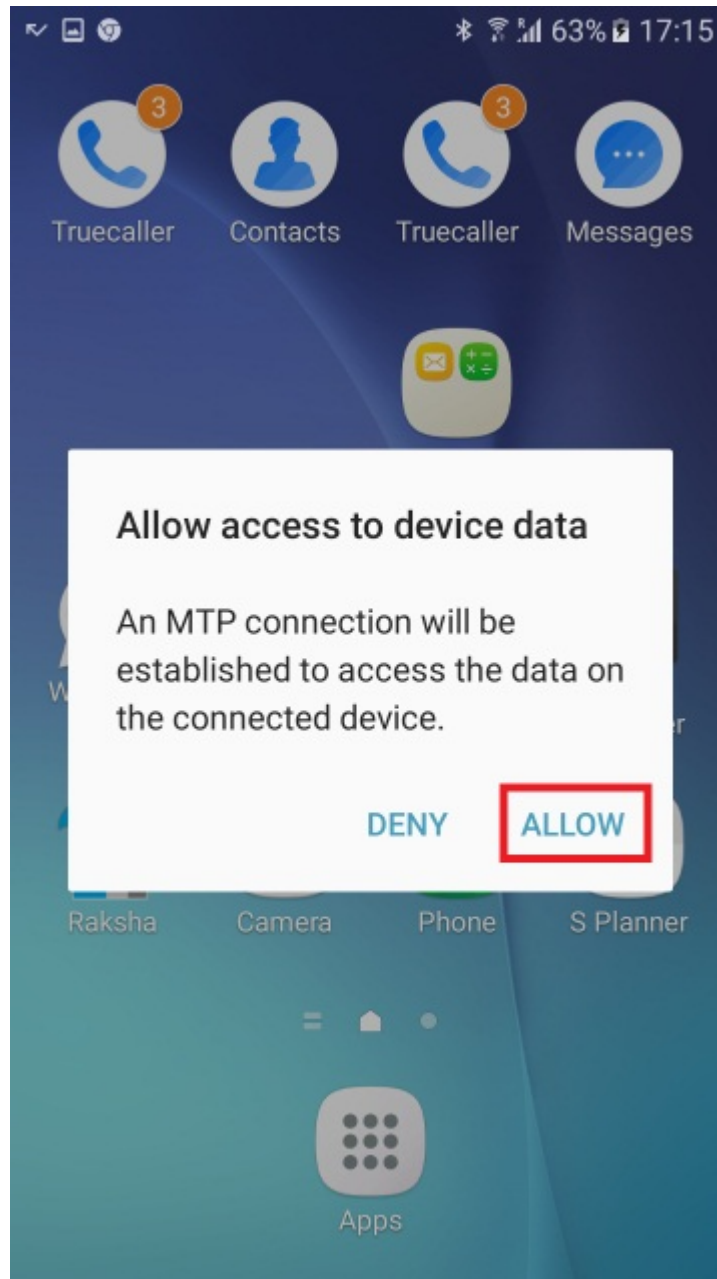

2. It is recommended to copy the Android App to the Download folder of the Android mobile device, as shown in the following figure.

Figure 12-2. Download Folder of the Android Device

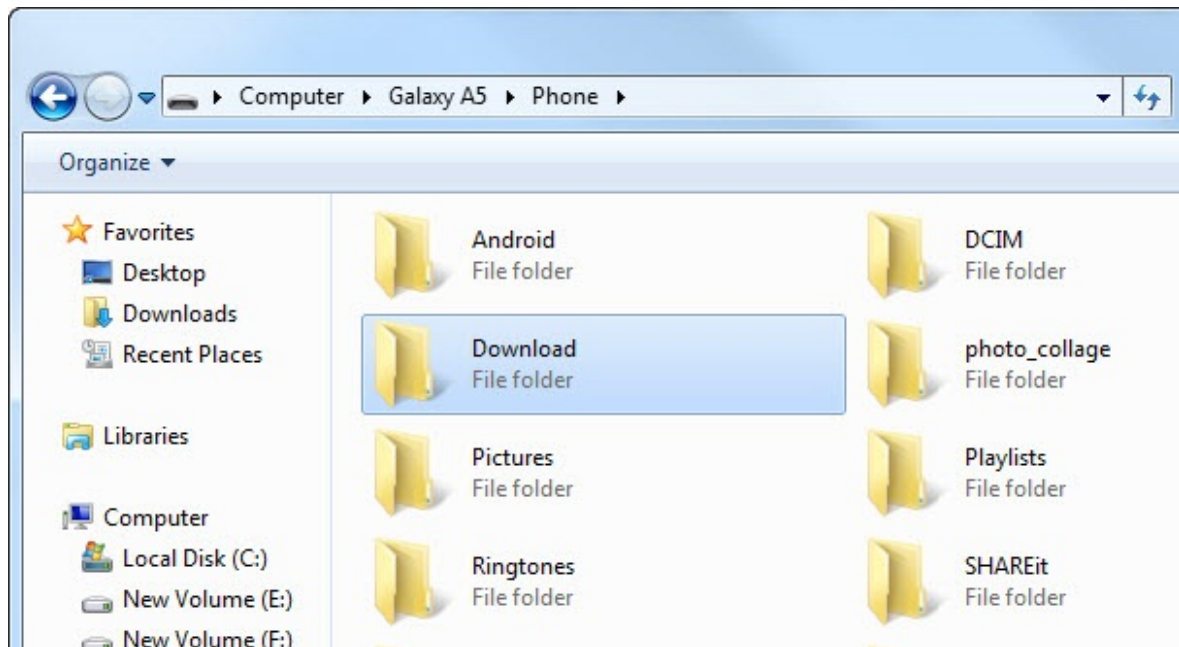

3. From **File Manager** of the mobile device, select *My Files > All Files > Download > MBA.apk*. After selecting the file, a warning message indicating the installation is blocked is displayed, see the following figure.

Figure 12-3. Warning Message: Install Blocked

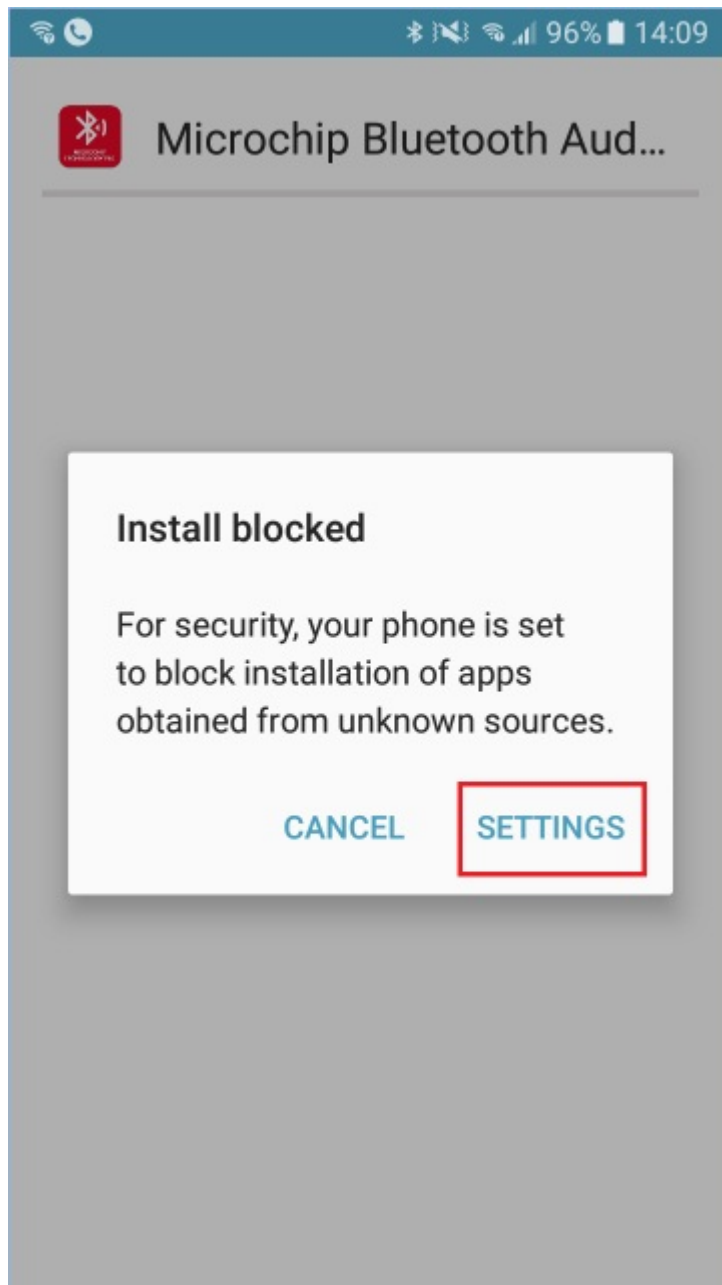

4. Go to **Settings** to open the **Security screen** and enable installations from **Unknown sources**, and then click **OK** to confirm the change, see the following figure.

Figure 12-4. Enable Installation From Unknown Sources

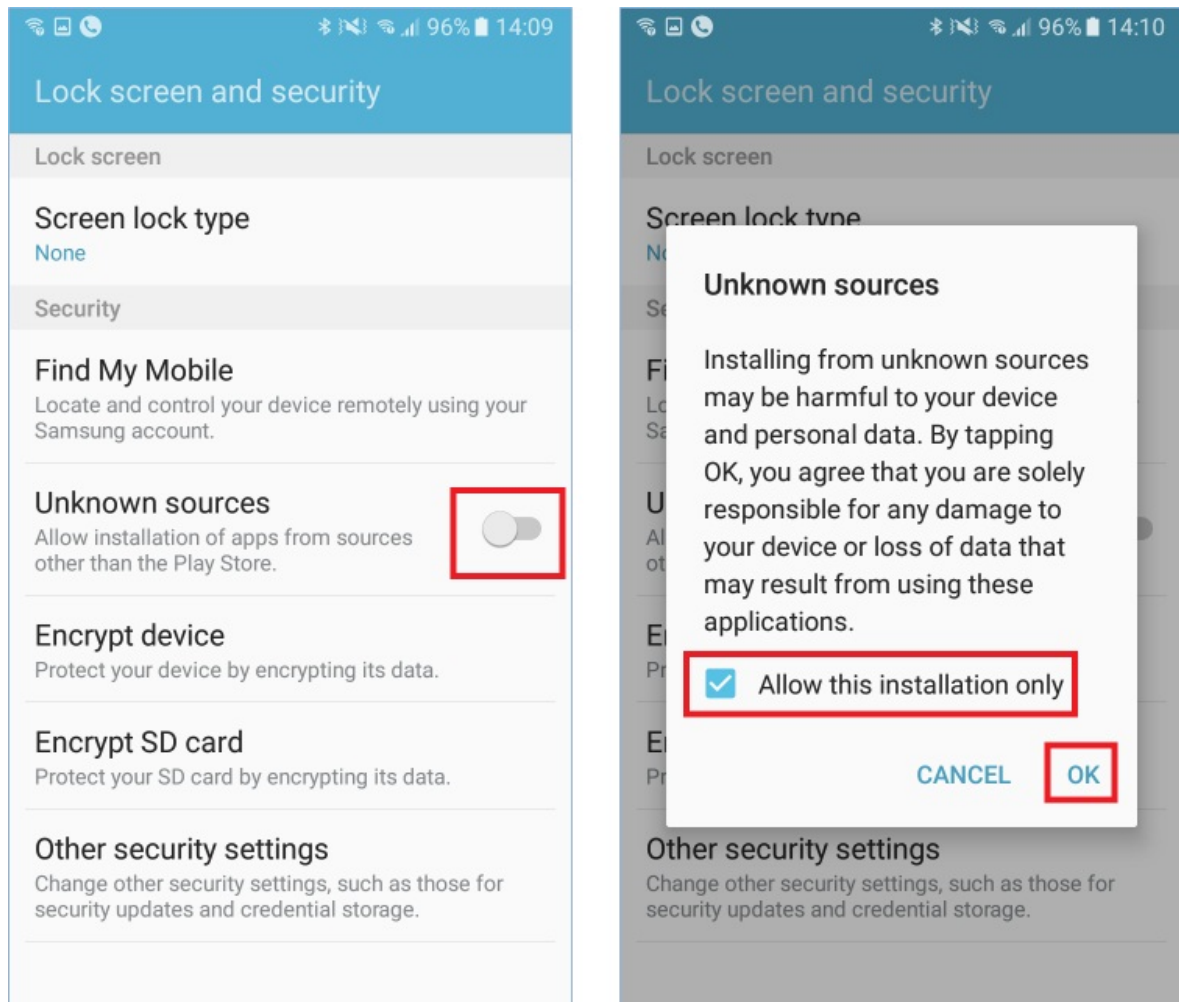

5. A message is displayed requesting whether to install an update to the existing application. Click **Install**. A confirmation screen displays when the application is installed, and then click **Open** to run the application, see the following figure.

Figure 12-5. Update and Install the App

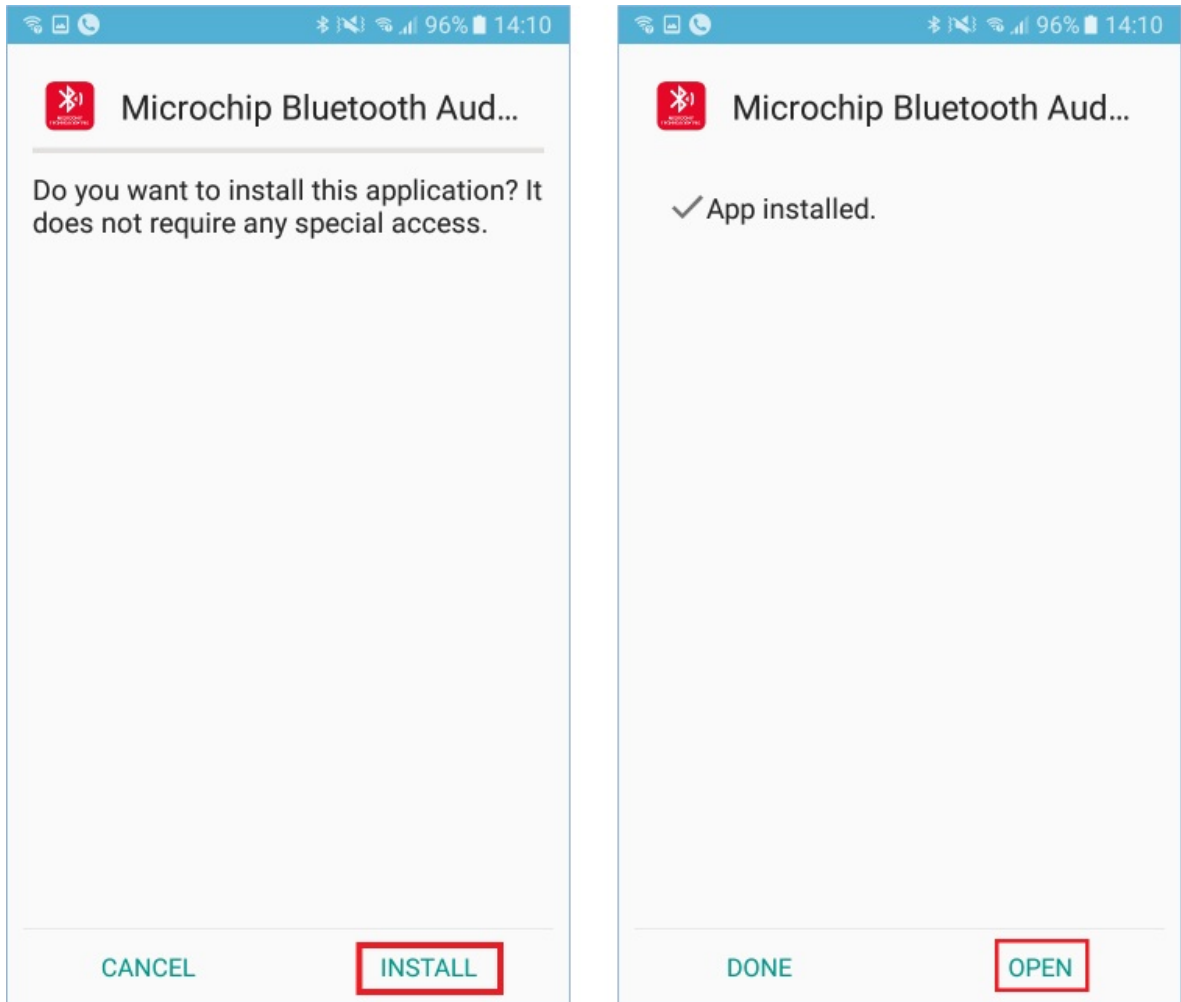

13. Appendix J: Configuring HID over GATT

1. Start *UITool_IS206x_012_DualModeSPK_v2.1.x.exe*.
2. Load *UITool_IS206x_012_DualModeSPK_v2.1.6_BM64_GATT.txt* then Click **Edit** and then click **Next**.
3. Click **BLE Setup** and enable random address advertising as shown in the following figure.

Figure 13-1. BLE Setup Settings

The screenshot shows the BLE Setup Settings window. The 'BLE Setup' tab is selected. The 'Enable Advertising Random Address' option is set to 'Enable' and is highlighted with a red box. A red '1' is next to the 'LE Slave Latency' field, and a red '2' is next to the 'Enable Advertising Random Address' field. The window contains various configuration options for BLE advertising and LE DIS settings.

Setting	Value	Range/Unit
LE Slave Latency	0x 0000	(0x0000~0x03E8) 1
LE Supervision Timeout	0x 0000	(0x000A~0x0C80, Unit: 10ms)
LE Advertising Setting		
LE Fast Advertising Timeout	3	(0: No timeout, 0~255: unit:10.24ms) Help
LE Reduced Power Advertising Timeout	18	(0: No timeout, 0~255: unit:10.24ms)
LE Reduced Power Advertising Interval	1022.5 ms	
Enable Advertising When Power On	Enable	
Enable Advertising During Standby Mode	Disable	
Enable Advertising Random Address	Enable	2
Enable Advertising On Enter Pairing	Disable	
LE DIS Setting		
Manufacture Name	MCHP	(Max:16 Char) Help
Model Name	Dual Speaker	(Max:16 Char)
Serial Number	0	(Max:16 Char)
Software	0000	(Max:16 Char)

4. Click the **GATT Service Table Setup** tab and select Human Interface Device Service and populate it as shown in the following figure.

Figure 13-2. GATT Service Table Setup Settings

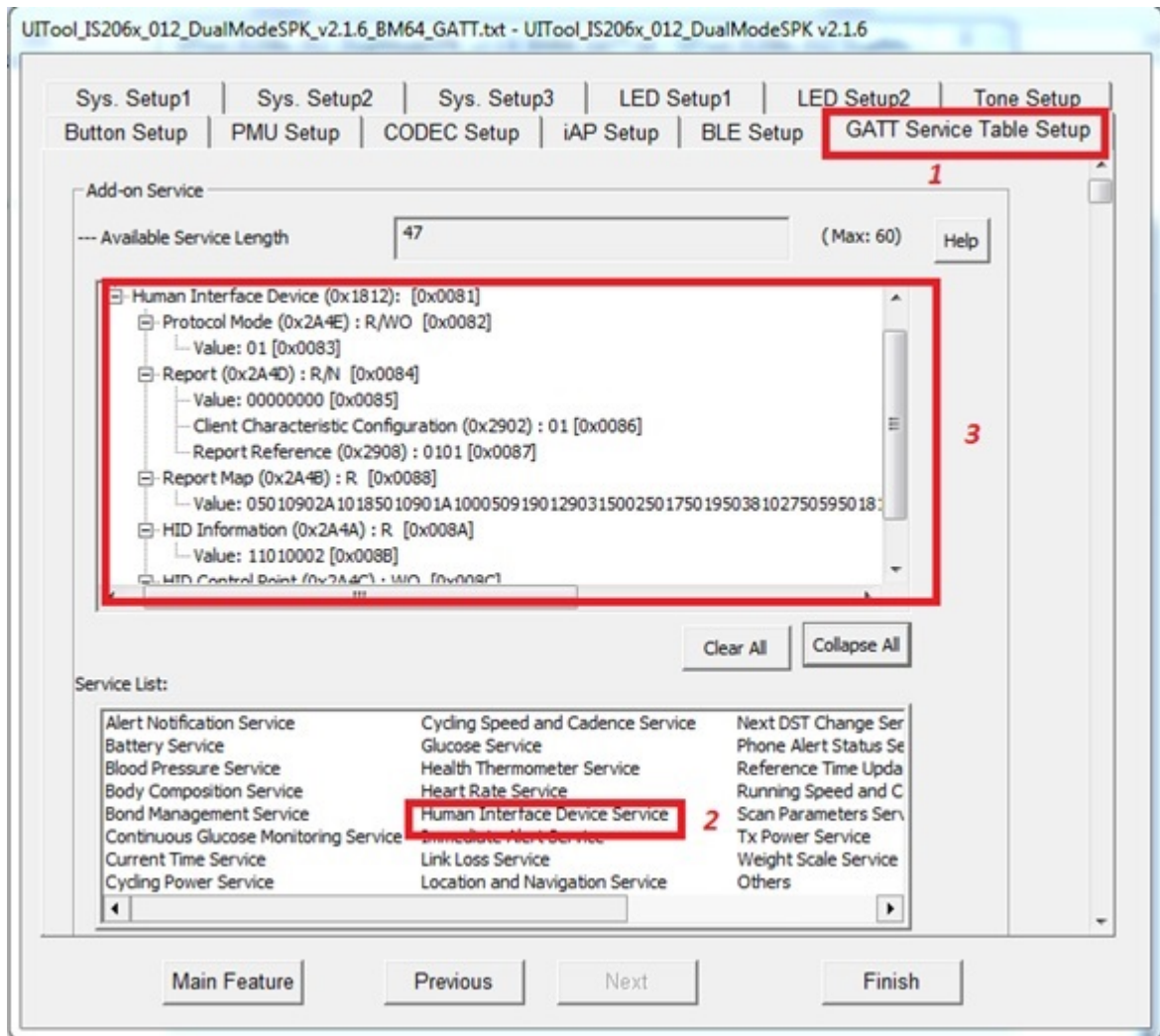

14. Appendix K: Routing Audio to SPK in BM64

To route audio to SPK, select **External CODEC** as internal codec as illustrated in the following figure.

Figure 14-1. External CODEC Settings

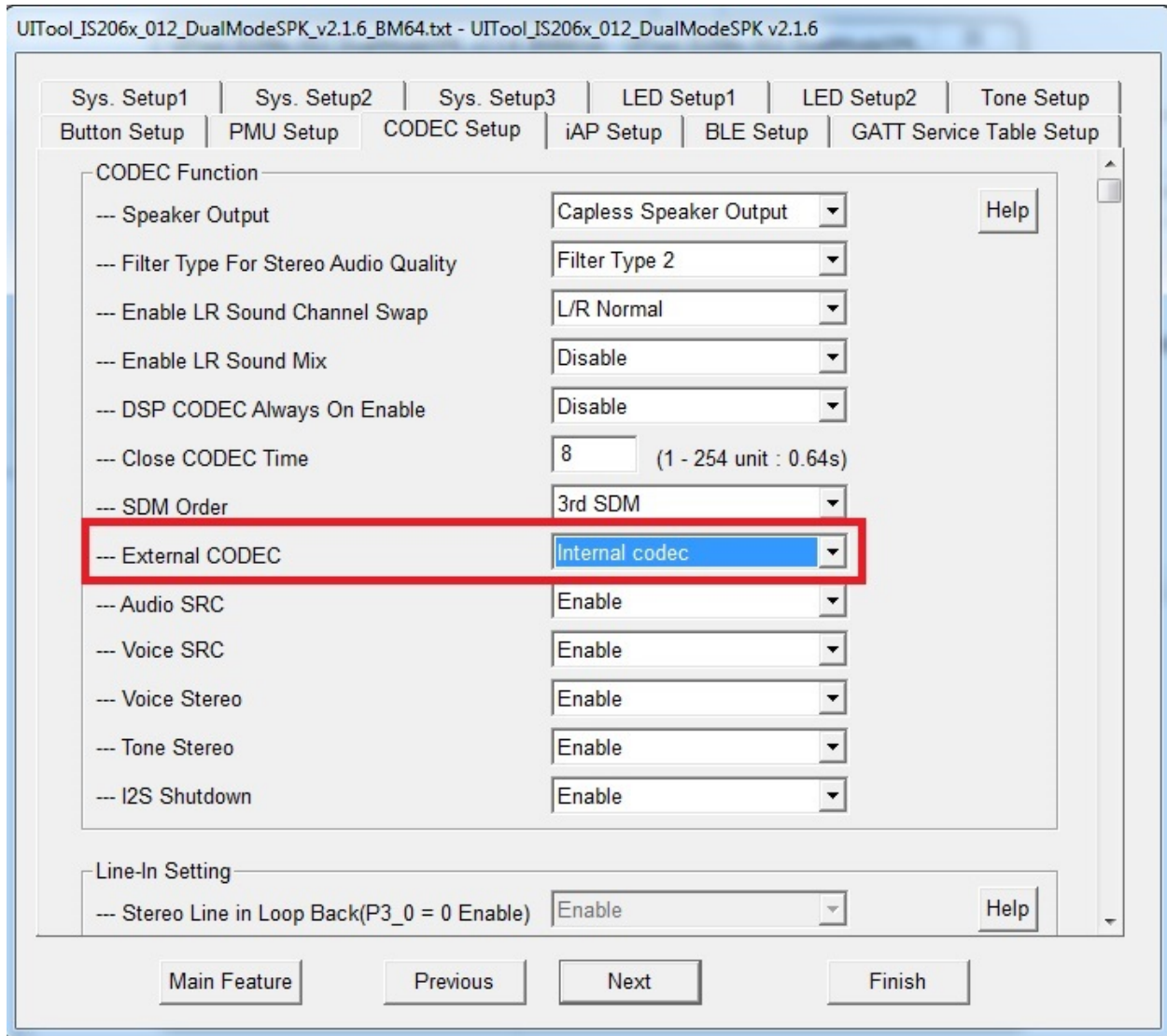

15. Appendix L: UPLINK SRC(48K->8K/16K), Voice, and Tone Stereo

For “External CODEC” choose *External codec* and *Enable* for “Audio SRC” and “Video SRC” in the UI tool as shown in the following figure. Voice and tone stereo settings are also available on this page and there is no dependency between SRC and tone stereo. Voice and tone stereo can work independently.

Figure 15-1. Choosing External Code and Enabling Audio SRC and Voice SRC

The screenshot shows the 'CODEC Function' configuration window. The settings are as follows:

- Speaker Output: Capless Speaker Output
- Filter Type For Stereo Audio Quality: Filter Type 2
- Enable LR Sound Channel Swap: L/R Normal
- Enable LR Sound Mix: Disable
- DSP CODEC Always On Enable: Disable
- Close CODEC Time: 8 (1 - 254 unit : 0.64s)
- SDM Order: 3rd SDM
- External CODEC: External codec (2)
- Audio SRC: Enable (3)
- Voice SRC: Enable (4)
- Voice Stereo: Enable (5)
- Tone Stereo: Enable (6)
- I2S Shutdown: Disable

The 'Line-In Setting' section shows:

- Stereo Line in Loop Back(P3_0 = 0 Enable): Enable

Navigation buttons: Main Feature, Previous, Next, Finish.

Table 15-1. Relation between Stereos and SRC

Voice Stereo	Tone Stereo	Audio/Voice SRC ⁽¹⁾	Description
Disable	Disable	X	No stereo
Enable	Disable	X	Voice stereo enabled
Disable	Enable	X	Tone stereo enabled
Enable	Enable	X	Voice and tone stereo enabled

1. X denotes do not care.

Choose the ADC selection as *External ADC* in DSP tool as shown in the following figure.

Figure 15-2. ADC Selection

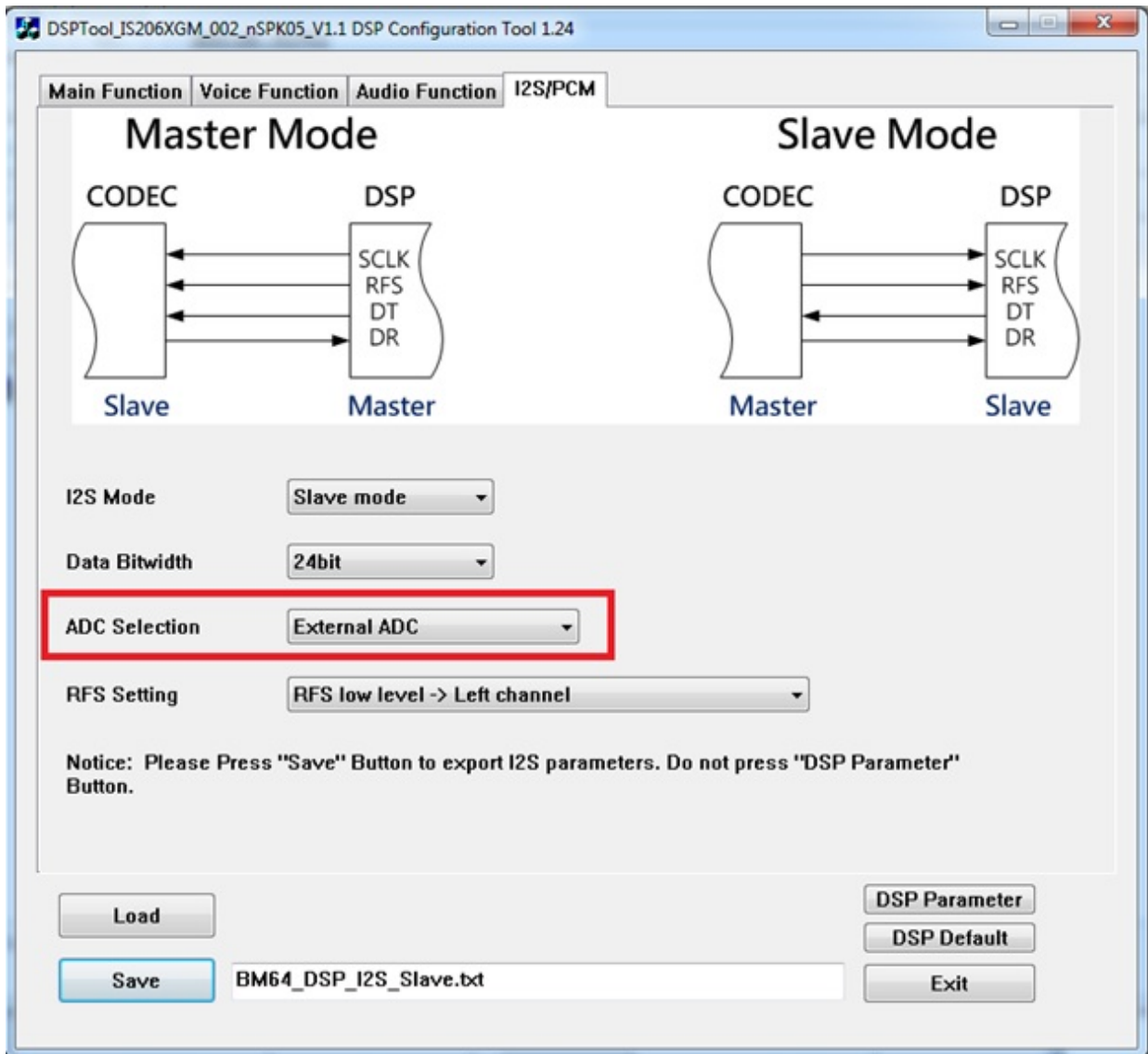

Note: External codec/DSP should be configured @48K sampling frequency and microphone should be attached to this codec/DSP. For HFP call, microphone input is coming from external codec/DSP through I2S input @48K to BM64. BM64 will perform ULSRC(48K->8K/16K) internally.

16. Appendix M: AVRCP Selection

AVRCP can be downgraded to v1.3 as shown in the following figure.

Figure 16-1. AVRCP Selection

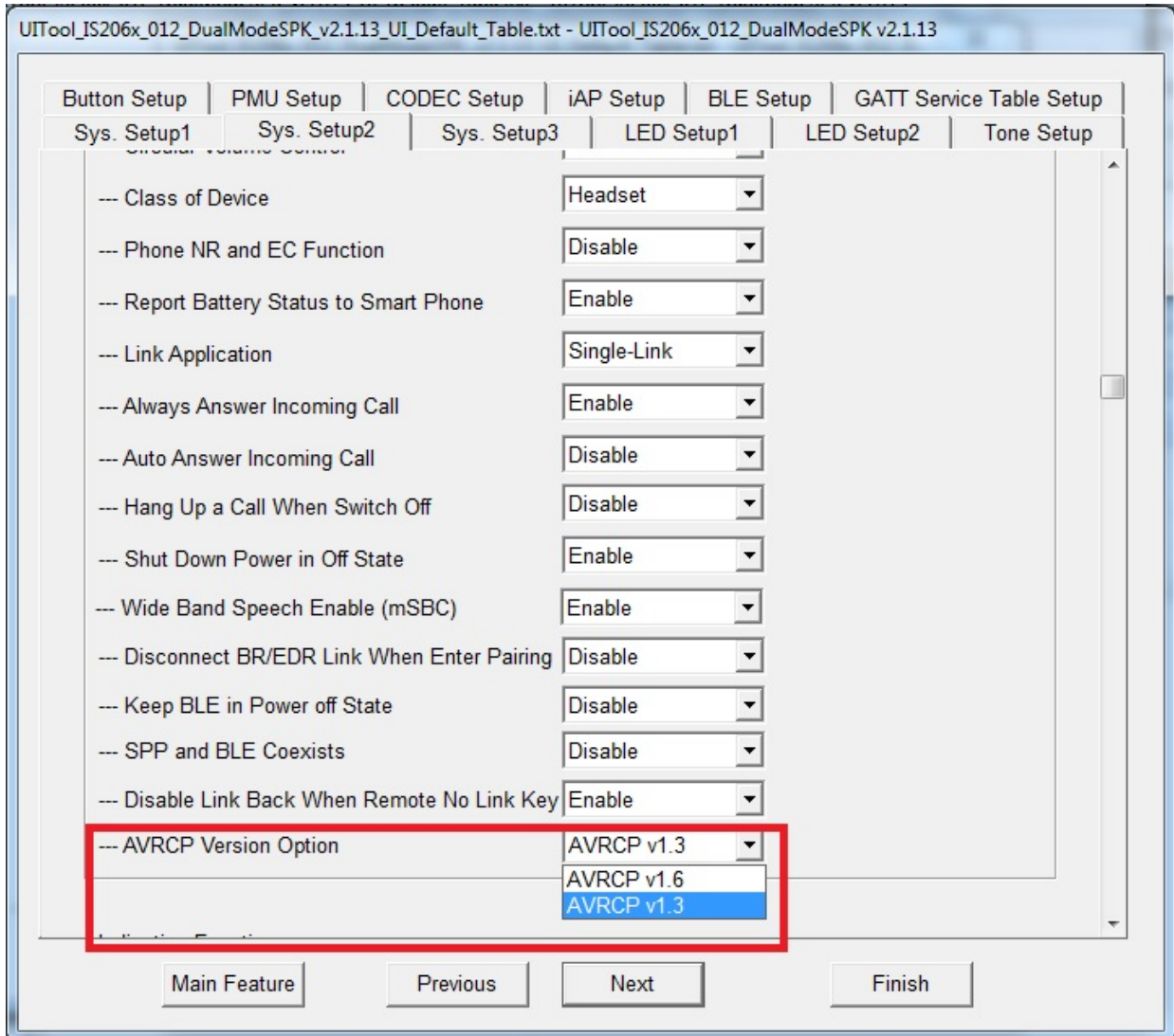

17. Appendix N: BLE Advertisement Name

The UI tool allows the user to setup both the classic BT name and BLE advertisement name. By default, FW adds “LE_” with the classic BT name to be the BLE advertisement name. The user can change the BLE advertisement name in the **BLE Setup** tab (see following figure).

Figure 17-1. Classic BT Name

The screenshot shows the BLE Setup tab with the following configuration:

PMU Setup	CODEC Setup	iAP Setup	BLE Setup	GATT Setup
Sys. Setup1	Sys. Setup2	Sys. Setup3	LED Setup1	LED Setup2
Tone Setup				

--- Name Fragment: (32 Char)

Figure 17-2. Default BLE Advertisement Name

The screenshot shows the BLE Setup tab with the following configuration:

Sys. Setup1	Sys. Setup2	Sys. Setup3	LED Setup1	LED Setup2	Tone Setup	Button Setup
PMU Setup	CODEC Setup	iAP Setup	BLE Setup	GATT Service Table Setup		

--- MIDI Service: Help

--- Transparent Service UUID: 0x (16 Bytes)

--- Transparent TX UUID: 0x (16 Bytes)

--- Transparent RX UUID: 0x (16 Bytes)

--- Transparent TX Permission: Help

Advertising Data Setting

--- Advertising Data Length: 0x (Max: 28) Help

Device Name:

Customized ADV Local Name

UUID: 0x

Manufacture Data: 0x

MBA Identify Enable: 0x

By default, when “Customized ADV Local Name” is disabled, FW will append “LE_” with the classic BT name to be the BLE advertisement name. The user can customize the name by enabling the check box.

Figure 17-3. Customized BLE Advertisement Name

Sys. Setup1	Sys. Setup2	Sys. Setup3	LED Setup1	LED Setup2	Tone Setup	Button Setup
PMU Setup	CODEC Setup	iAP Setup	BLE Setup	GATT Service Table Setup		
--- MIDI Service			Disable		Help	
--- Transparent Service UUID			0x 49535343FE7D4AE58FA99FAFD205E455	(16 Bytes)		
--- Transparent TX UUID			0x 495353431E4D4BD9BA6123C647249616	(16 Bytes)		
--- Transparent RX UUID			0x 49535343884143F4A8D4ECBE34729BB3	(16 Bytes)		
--- Transparent TX Permission			0x00: Disable			
Advertising Data Setting						
--- Advertising Data Length			0x 17	(Max: 28)	Help	
<input checked="" type="checkbox"/> Device Name			customized_name			
<input checked="" type="checkbox"/> Customized ADV Local Name						
<input type="checkbox"/> UUID			0x			
<input type="checkbox"/> Manufacture Data			0x			

18. Document Revision History

Table 18-1. Document Revision History

Revision	Date	Section	Description
D	01/2020	<ul style="list-style-type: none"> 1.3 Firmware Capabilities and Features 6.1 Selecting UI Parameters 15. Appendix L: UPLINK SRC(48K->8K/16K), Voice, and Tone Stereo 	Updated
		17. Appendix N: BLE Advertisement Name	Added
C	07/2019	<ul style="list-style-type: none"> 15. Appendix L: UPLINK SRC(48K->8K/16K), Voice, and Tone Stereo 16. Appendix M: AVRCP Selection 	Added
B	02/2018	<ul style="list-style-type: none"> AN# in the header Dual speaker in the title to Dual mode speaker 	Updated
A	02/2018	Document	Initial revision

The Microchip Website

Microchip provides online support via our website at <http://www.microchip.com/>. This website is used to make files and information easily available to customers. Some of the content available includes:

- **Product Support** – Data sheets and errata, application notes and sample programs, design resources, user's guides and hardware support documents, latest software releases and archived software
- **General Technical Support** – Frequently Asked Questions (FAQs), technical support requests, online discussion groups, Microchip design partner program member listing
- **Business of Microchip** – Product selector and ordering guides, latest Microchip press releases, listing of seminars and events, listings of Microchip sales offices, distributors and factory representatives

Product Change Notification Service

Microchip's product change notification service helps keep customers current on Microchip products. Subscribers will receive email notification whenever there are changes, updates, revisions or errata related to a specified product family or development tool of interest.

To register, go to <http://www.microchip.com/pcn> and follow the registration instructions.

Customer Support

Users of Microchip products can receive assistance through several channels:

- Distributor or Representative
- Local Sales Office
- Embedded Solutions Engineer (ESE)
- Technical Support

Customers should contact their distributor, representative or ESE for support. Local sales offices are also available to help customers. A listing of sales offices and locations is included in this document.

Technical support is available through the website at: <http://www.microchip.com/support>

Microchip Devices Code Protection Feature

Note the following details of the code protection feature on Microchip devices:

- Microchip products meet the specification contained in their particular Microchip Data Sheet.
- Microchip believes that its family of products is one of the most secure families of its kind on the market today, when used in the intended manner and under normal conditions.
- There are dishonest and possibly illegal methods used to breach the code protection feature. All of these methods, to our knowledge, require using the Microchip products in a manner outside the operating specifications contained in Microchip's Data Sheets. Most likely, the person doing so is engaged in theft of intellectual property.
- Microchip is willing to work with the customer who is concerned about the integrity of their code.
- Neither Microchip nor any other semiconductor manufacturer can guarantee the security of their code. Code protection does not mean that we are guaranteeing the product as "unbreakable."

Code protection is constantly evolving. We at Microchip are committed to continuously improving the code protection features of our products. Attempts to break Microchip's code protection feature may be a violation of the Digital Millennium Copyright Act. If such acts allow unauthorized access to your software or other copyrighted work, you may have a right to sue for relief under that Act.

Legal Notice

Information contained in this publication regarding device applications and the like is provided only for your convenience and may be superseded by updates. It is your responsibility to ensure that your application meets with

your specifications. MICROCHIP MAKES NO REPRESENTATIONS OR WARRANTIES OF ANY KIND WHETHER EXPRESS OR IMPLIED, WRITTEN OR ORAL, STATUTORY OR OTHERWISE, RELATED TO THE INFORMATION, INCLUDING BUT NOT LIMITED TO ITS CONDITION, QUALITY, PERFORMANCE, MERCHANTABILITY OR FITNESS FOR PURPOSE. Microchip disclaims all liability arising from this information and its use. Use of Microchip devices in life support and/or safety applications is entirely at the buyer's risk, and the buyer agrees to defend, indemnify and hold harmless Microchip from any and all damages, claims, suits, or expenses resulting from such use. No licenses are conveyed, implicitly or otherwise, under any Microchip intellectual property rights unless otherwise stated.

Trademarks

The Microchip name and logo, the Microchip logo, Adaptec, AnyRate, AVR, AVR logo, AVR Freaks, BesTime, BitCloud, chipKIT, chipKIT logo, CryptoMemory, CryptoRF, dsPIC, FlashFlex, flexPWR, HELDO, IGLOO, JukeBlox, KeeLoq, Kleer, LANCheck, LinkMD, maXStylus, maXTouch, MediaLB, megaAVR, Microsemi, Microsemi logo, MOST, MOST logo, MPLAB, OptoLyzer, PackeTime, PIC, picoPower, PICSTART, PIC32 logo, PolarFire, Prochip Designer, QTouch, SAM-BA, SenGenuity, SpyNIC, SST, SST Logo, SuperFlash, Symmetricom, SyncServer, Tachyon, TempTrackr, TimeSource, tinyAVR, UNI/O, Vectron, and XMEGA are registered trademarks of Microchip Technology Incorporated in the U.S.A. and other countries.

APT, ClockWorks, The Embedded Control Solutions Company, EtherSynch, FlashTec, Hyper Speed Control, HyperLight Load, IntelliMOS, Libero, motorBench, mTouch, Powermite 3, Precision Edge, ProASIC, ProASIC Plus, ProASIC Plus logo, Quiet-Wire, SmartFusion, SyncWorld, Temux, TimeCesium, TimeHub, TimePictra, TimeProvider, Vite, WinPath, and ZL are registered trademarks of Microchip Technology Incorporated in the U.S.A.

Adjacent Key Suppression, AKS, Analog-for-the-Digital Age, Any Capacitor, AnyIn, AnyOut, BlueSky, BodyCom, CodeGuard, CryptoAuthentication, CryptoAutomotive, CryptoCompanion, CryptoController, dsPICDEM, dsPICDEM.net, Dynamic Average Matching, DAM, ECAN, EtherGREEN, In-Circuit Serial Programming, ICSP, INICnet, Inter-Chip Connectivity, JitterBlocker, KleerNet, KleerNet logo, memBrain, Mindi, MiWi, MPASM, MPF, MPLAB Certified logo, MPLIB, MPLINK, MultiTRAK, NetDetach, Omniscient Code Generation, PICDEM, PICDEM.net, PICkit, PICtail, PowerSmart, PureSilicon, QMatrix, REAL ICE, Ripple Blocker, SAM-ICE, Serial Quad I/O, SMART-I.S., SQI, SuperSwitcher, SuperSwitcher II, Total Endurance, TSHARC, USBCheck, VariSense, ViewSpan, WiperLock, Wireless DNA, and ZENA are trademarks of Microchip Technology Incorporated in the U.S.A. and other countries.

SQTP is a service mark of Microchip Technology Incorporated in the U.S.A.

The Adaptec logo, Frequency on Demand, Silicon Storage Technology, and Symmcom are registered trademarks of Microchip Technology Inc. in other countries.

GestIC is a registered trademark of Microchip Technology Germany II GmbH & Co. KG, a subsidiary of Microchip Technology Inc., in other countries.

All other trademarks mentioned herein are property of their respective companies.

© 2020, Microchip Technology Incorporated, Printed in the U.S.A., All Rights Reserved.

ISBN: 978-1-5224-5482-3

Quality Management System

For information regarding Microchip's Quality Management Systems, please visit <http://www.microchip.com/quality>.

Worldwide Sales and Service

AMERICAS	ASIA/PACIFIC	ASIA/PACIFIC	EUROPE
<p>Corporate Office 2355 West Chandler Blvd. Chandler, AZ 85224-6199 Tel: 480-792-7200 Fax: 480-792-7277 Technical Support: http://www.microchip.com/support Web Address: http://www.microchip.com</p> <p>Atlanta Duluth, GA Tel: 678-957-9614 Fax: 678-957-1455</p> <p>Austin, TX Tel: 512-257-3370</p> <p>Boston Westborough, MA Tel: 774-760-0087 Fax: 774-760-0088</p> <p>Chicago Itasca, IL Tel: 630-285-0071 Fax: 630-285-0075</p> <p>Dallas Addison, TX Tel: 972-818-7423 Fax: 972-818-2924</p> <p>Detroit Novi, MI Tel: 248-848-4000</p> <p>Houston, TX Tel: 281-894-5983</p> <p>Indianapolis Noblesville, IN Tel: 317-773-8323 Fax: 317-773-5453 Tel: 317-536-2380</p> <p>Los Angeles Mission Viejo, CA Tel: 949-462-9523 Fax: 949-462-9608 Tel: 951-273-7800</p> <p>Raleigh, NC Tel: 919-844-7510</p> <p>New York, NY Tel: 631-435-6000</p> <p>San Jose, CA Tel: 408-735-9110 Tel: 408-436-4270</p> <p>Canada - Toronto Tel: 905-695-1980 Fax: 905-695-2078</p>	<p>Australia - Sydney Tel: 61-2-9868-6733</p> <p>China - Beijing Tel: 86-10-8569-7000</p> <p>China - Chengdu Tel: 86-28-8665-5511</p> <p>China - Chongqing Tel: 86-23-8980-9588</p> <p>China - Dongguan Tel: 86-769-8702-9880</p> <p>China - Guangzhou Tel: 86-20-8755-8029</p> <p>China - Hangzhou Tel: 86-571-8792-8115</p> <p>China - Hong Kong SAR Tel: 852-2943-5100</p> <p>China - Nanjing Tel: 86-25-8473-2460</p> <p>China - Qingdao Tel: 86-532-8502-7355</p> <p>China - Shanghai Tel: 86-21-3326-8000</p> <p>China - Shenyang Tel: 86-24-2334-2829</p> <p>China - Shenzhen Tel: 86-755-8864-2200</p> <p>China - Suzhou Tel: 86-186-6233-1526</p> <p>China - Wuhan Tel: 86-27-5980-5300</p> <p>China - Xian Tel: 86-29-8833-7252</p> <p>China - Xiamen Tel: 86-592-2388138</p> <p>China - Zhuhai Tel: 86-756-3210040</p>	<p>India - Bangalore Tel: 91-80-3090-4444</p> <p>India - New Delhi Tel: 91-11-4160-8631</p> <p>India - Pune Tel: 91-20-4121-0141</p> <p>Japan - Osaka Tel: 81-6-6152-7160</p> <p>Japan - Tokyo Tel: 81-3-6880-3770</p> <p>Korea - Daegu Tel: 82-53-744-4301</p> <p>Korea - Seoul Tel: 82-2-554-7200</p> <p>Malaysia - Kuala Lumpur Tel: 60-3-7651-7906</p> <p>Malaysia - Penang Tel: 60-4-227-8870</p> <p>Philippines - Manila Tel: 63-2-634-9065</p> <p>Singapore Tel: 65-6334-8870</p> <p>Taiwan - Hsin Chu Tel: 886-3-577-8366</p> <p>Taiwan - Kaohsiung Tel: 886-7-213-7830</p> <p>Taiwan - Taipei Tel: 886-2-2508-8600</p> <p>Thailand - Bangkok Tel: 66-2-694-1351</p> <p>Vietnam - Ho Chi Minh Tel: 84-28-5448-2100</p>	<p>Austria - Wels Tel: 43-7242-2244-39 Fax: 43-7242-2244-393</p> <p>Denmark - Copenhagen Tel: 45-4450-2828 Fax: 45-4485-2829</p> <p>Finland - Espoo Tel: 358-9-4520-820</p> <p>France - Paris Tel: 33-1-69-53-63-20 Fax: 33-1-69-30-90-79</p> <p>Germany - Garching Tel: 49-8931-9700</p> <p>Germany - Haan Tel: 49-2129-3766400</p> <p>Germany - Heilbronn Tel: 49-7131-72400</p> <p>Germany - Karlsruhe Tel: 49-721-625370</p> <p>Germany - Munich Tel: 49-89-627-144-0 Fax: 49-89-627-144-44</p> <p>Germany - Rosenheim Tel: 49-8031-354-560</p> <p>Israel - Ra'anana Tel: 972-9-744-7705</p> <p>Italy - Milan Tel: 39-0331-742611 Fax: 39-0331-466781</p> <p>Italy - Padova Tel: 39-049-7625286</p> <p>Netherlands - Druenen Tel: 31-416-690399 Fax: 31-416-690340</p> <p>Norway - Trondheim Tel: 47-72884388</p> <p>Poland - Warsaw Tel: 48-22-3325737</p> <p>Romania - Bucharest Tel: 40-21-407-87-50</p> <p>Spain - Madrid Tel: 34-91-708-08-90 Fax: 34-91-708-08-91</p> <p>Sweden - Gothenberg Tel: 46-31-704-60-40</p> <p>Sweden - Stockholm Tel: 46-8-5090-4654</p> <p>UK - Wokingham Tel: 44-118-921-5800 Fax: 44-118-921-5820</p>