



MICROCHIP

**EVB-USB7002
Evaluation Kit
User's Guide**

Note the following details of the code protection feature on Microchip products:

- Microchip products meet the specifications contained in their particular Microchip Data Sheet.
- Microchip believes that its family of products is secure when used in the intended manner, within operating specifications, and under normal conditions.
- Microchip values and aggressively protects its intellectual property rights. Attempts to breach the code protection features of Microchip product is strictly prohibited and may violate the Digital Millennium Copyright Act.
- Neither Microchip nor any other semiconductor manufacturer can guarantee the security of its code. Code protection does not mean that we are guaranteeing the product is "unbreakable" Code protection is constantly evolving. Microchip is committed to continuously improving the code protection features of our products.

This publication and the information herein may be used only with Microchip products, including to design, test, and integrate Microchip products with your application. Use of this information in any other manner violates these terms. Information regarding device applications is provided only for your convenience and may be superseded by updates. It is your responsibility to ensure that your application meets with your specifications. Contact your local Microchip sales office for additional support or, obtain additional support at <https://www.microchip.com/en-us/support/design-help/client-support-services>.

THIS INFORMATION IS PROVIDED BY MICROCHIP "AS IS". MICROCHIP MAKES NO REPRESENTATIONS OR WARRANTIES OF ANY KIND WHETHER EXPRESS OR IMPLIED, WRITTEN OR ORAL, STATUTORY OR OTHERWISE, RELATED TO THE INFORMATION INCLUDING BUT NOT LIMITED TO ANY IMPLIED WARRANTIES OF NON-INFRINGEMENT, MERCHANTABILITY, AND FITNESS FOR A PARTICULAR PURPOSE, OR WARRANTIES RELATED TO ITS CONDITION, QUALITY, OR PERFORMANCE.

IN NO EVENT WILL MICROCHIP BE LIABLE FOR ANY INDIRECT, SPECIAL, PUNITIVE, INCIDENTAL, OR CONSEQUENTIAL LOSS, DAMAGE, COST, OR EXPENSE OF ANY KIND WHATSOEVER RELATED TO THE INFORMATION OR ITS USE, HOWEVER CAUSED, EVEN IF MICROCHIP HAS BEEN ADVISED OF THE POSSIBILITY OR THE DAMAGES ARE FORESEEABLE. TO THE FULLEST EXTENT ALLOWED BY LAW, MICROCHIP'S TOTAL LIABILITY ON ALL CLAIMS IN ANY WAY RELATED TO THE INFORMATION OR ITS USE WILL NOT EXCEED THE AMOUNT OF FEES, IF ANY, THAT YOU HAVE PAID DIRECTLY TO MICROCHIP FOR THE INFORMATION.

Use of Microchip devices in life support and/or safety applications is entirely at the buyer's risk, and the buyer agrees to defend, indemnify and hold harmless Microchip from any and all damages, claims, suits, or expenses resulting from such use. No licenses are conveyed, implicitly or otherwise, under any Microchip intellectual property rights unless otherwise stated.

Trademarks

The Microchip name and logo, the Microchip logo, Adaptec, AVR, AVR logo, AVR Freaks, BesTime, BitCloud, CryptoMemory, CryptoRF, dsPIC, flexPWR, HELDO, IGLOO, JukeBlox, KeeLoq, Kleer, LANCheck, LinkMD, maXStylus, maXTouch, MediaLB, megaAVR, Microsemi, Microsemi logo, MOST, MOST logo, MPLAB, OptoLyzer, PIC, picoPower, PICSTART, PIC32 logo, PolarFire, Prochip Designer, QTouch, SAM-BA, SenGenuity, SpyNIC, SST, SST Logo, SuperFlash, Symmetricom, SyncServer, Tachyon, TimeSource, tinyAVR, UNI/O, Vectron, and XMEGA are registered trademarks of Microchip Technology Incorporated in the U.S.A. and other countries.

AgileSwitch, APT, ClockWorks, The Embedded Control Solutions Company, EtherSynch, Flashtec, Hyper Speed Control, HyperLight Load, Libero, motorBench, mTouch, Powermite 3, Precision Edge, ProASIC, ProASIC Plus, ProASIC Plus logo, Quiet-Wire, SmartFusion, SyncWorld, Temux, TimeCesium, TimeHub, TimePictra, TimeProvider, TrueTime, and ZL are registered trademarks of Microchip Technology Incorporated in the U.S.A.

Adjacent Key Suppression, AKS, Analog-for-the-Digital Age, Any Capacitor, AnyIn, AnyOut, Augmented Switching, BlueSky, BodyCom, Clockstudio, CodeGuard, CryptoAuthentication, CryptoAutomotive, CryptoCompanion, CryptoController, dsPICDEM, dsPICDEM.net, Dynamic Average Matching, DAM, ECAN, Espresso T1S, EtherGREEN, GridTime, IdealBridge, In-Circuit Serial Programming, ICSP, INICnet, Intelligent Paralleling, IntelliMOS, Inter-Chip Connectivity, JitterBlocker, Knob-on-Display, KoD, maxCrypto, maxView, memBrain, Mindi, MiWi, MPASM, MPF, MPLAB Certified logo, MPLIB, MPLINK, MultiTRAK, NetDetach, Omniscient Code Generation, PICDEM, PICDEM.net, PICkit, PICtail, PowerSmart, PureSilicon, QMatrix, REAL ICE, Ripple Blocker, RTAX, RTG4, SAM-ICE, Serial Quad I/O, simpleMAP, SimpliPHY, SmartBuffer, SmartHLS, SMART-I.S., storClad, SQL, SuperSwitcher, SuperSwitcher II, Switchtec, SynchroPHY, Total Endurance, Trusted Time, TSHARC, USBCheck, VariSense, VectorBlox, VeriPHY, ViewSpan, WiperLock, XpressConnect, and ZENA are trademarks of Microchip Technology Incorporated in the U.S.A. and other countries.

SQTP is a service mark of Microchip Technology Incorporated in the U.S.A.

The Adaptec logo, Frequency on Demand, Silicon Storage Technology, and Symmcom are registered trademarks of Microchip Technology Inc. in other countries.

GestIC is a registered trademark of Microchip Technology Germany II GmbH & Co. KG, a subsidiary of Microchip Technology Inc., in other countries.

All other trademarks mentioned herein are property of their respective companies.

© 2018-2023, Microchip Technology Incorporated and its subsidiaries.

All Rights Reserved.

ISBN: 978-1-6683-2206-2

For information regarding Microchip's Quality Management Systems, please visit www.microchip.com/quality.

Table of Contents

Preface	5
Introduction.....	5
Document Layout	5
Conventions Used in this Guide	6
Warranty Registration.....	7
The Microchip Web Site	7
Development Systems Customer Change Notification Service	7
Customer Support	8
Document Revision History	8
 Chapter 1. Overview	
1.1 Introduction	9
1.2 Features	9
1.3 Block Diagram	10
1.4 References	12
1.5 Acronyms and Definitions	12
 Chapter 2. Getting Started	
2.1 Introduction	13
2.2 Kit Contents	13
2.3 Quick Start	13
 Chapter 3. Hardware Configuration	
3.1 Hardware Configuration Options	15
3.1.1 Configuration	15
3.1.2 Power Source - Self Powered	17
3.1.3 Downstream Port Power Control	17
3.1.4 USB Type-C Ports	17
3.1.5 LED Indicators	17
3.1.6 Switches	18
3.1.7 Connector Descriptions	18
3.1.8 Test Points	19
 Appendix A. Schematics	
A.1 Introduction	21
 Appendix B. Bill of Materials	
B.1 Introduction	31
 Appendix C. PCB Silk Screens	
C.1 Introduction	37
 Worldwide Sales and Service	40

EVB-USB7002 Evaluation Kit User's Guide

NOTES:

Preface

NOTICE TO CUSTOMERS

All documentation becomes dated, and this manual is no exception. Microchip tools and documentation are constantly evolving to meet customer needs, so some actual dialogs and/or tool descriptions may differ from those in this document. Please refer to our web site (www.microchip.com) to obtain the latest documentation available.

Documents are identified with a “DS” number. This number is located on the bottom of each page, in front of the page number. The numbering convention for the DS number is “DSXXXXA”, where “XXXX” is the document number and “A” is the revision level of the document.

For the most up-to-date information on development tools, see the MPLAB® IDE online help. Select the Help menu, and then Topics to open a list of available online help files.

INTRODUCTION

This chapter contains general information that will be useful to know before using the EVB-USB7002 Evaluation Kit. Items discussed in this chapter include:

- [Document Layout](#)
- [Conventions Used in this Guide](#)
- [Warranty Registration](#)
- [The Microchip Web Site](#)
- [Development Systems Customer Change Notification Service](#)
- [Customer Support](#)
- [Document Revision History](#)

DOCUMENT LAYOUT

This document describes how to use the EVB-USB7002 Evaluation Kit as a demonstration platform optimized for portable applications. The manual layout is as follows:

- **Chapter 1. “Overview”** – Shows a brief description of the EVB-USB7002 Evaluation Kit.
- **Chapter 2. “Getting Started”** – Provides information about setup and operation of the EVB-USB7002 Evaluation Kit.
- **Chapter 3. “Hardware Configuration”** – Includes information about the hardware configuration of the EVB-USB7002 Evaluation Kit.
- **Appendix A. “Schematics”** – This appendix shows the EVB-USB7002 Evaluation Kit schematics.
- **Appendix B. “Bill of Materials”** – This appendix includes the EVB-USB7002 Evaluation Kit Bill of Materials (BOM).
- **Appendix C. “PCB Silk Screens”** – This appendix includes the EVB-USB7002 Evaluation Kit silk screen.

CONVENTIONS USED IN THIS GUIDE

This manual uses the following documentation conventions:

DOCUMENTATION CONVENTIONS

Description	Represents	Examples
Arial font:		
Italic characters	Referenced books	<i>MPLAB® IDE User's Guide</i>
	Emphasized text	...is the <i>only</i> compiler...
Initial caps	A window	the Output window
	A dialog	the Settings dialog
	A menu selection	select Enable Programmer
Quotes	A field name in a window or dialog	"Save project before build"
Underlined, italic text with right angle bracket	A menu path	<u><i>File>Save</i></u>
Bold characters	A dialog button	Click OK
	A tab	Click the Power tab
N'Rnnnn	A number in verilog format, where N is the total number of digits, R is the radix and n is a digit.	4'b0010, 2'hF1
Text in angle brackets < >	A key on the keyboard	Press <Enter>, <F1>
Courier New font:		
Plain Courier New	Sample source code	#define START
	Filenames	autoexec.bat
	File paths	c:\mcc18\h
	Keywords	_asm, _endasm, static
	Command-line options	-Opa+, -Opa-
	Bit values	0, 1
	Constants	0xFF, 'A'
Italic Courier New	A variable argument	<i>file.o</i> , where <i>file</i> can be any valid filename
Square brackets []	Optional arguments	mcc18 [options] <i>file</i> [options]
Curly brackets and pipe character: { }	Choice of mutually exclusive arguments; an OR selection	errorlevel {0 1}
Ellipses...	Replaces repeated text	var_name [, var_name...]
	Represents code supplied by user	void main (void) { ... }

WARRANTY REGISTRATION

Please complete the enclosed Warranty Registration Card and mail it promptly. Sending the Warranty Registration Card entitles users to receive new product updates. Interim software releases are available at the Microchip web site.

THE MICROCHIP WEB SITE

Microchip provides online support via our web site at www.microchip.com. This web site is used as a means to make files and information easily available to customers. Accessible by using your favorite Internet browser, the web site contains the following information:

- **Product Support** – Data sheets and errata, application notes and sample programs, design resources, user's guides and hardware support documents, latest software releases and archived software
- **General Technical Support** – Frequently Asked Questions (FAQs), technical support requests, online discussion groups, Microchip consultant program member listing
- **Business of Microchip** – Product selector and ordering guides, latest Microchip press releases, listing of seminars and events, listings of Microchip sales offices, distributors and factory representatives

DEVELOPMENT SYSTEMS CUSTOMER CHANGE NOTIFICATION SERVICE

Microchip's customer notification service helps keep customers current on Microchip products. Subscribers will receive e-mail notification whenever there are changes, updates, revisions or errata related to a specified product family or development tool of interest.

To register, access the Microchip web site at www.microchip.com, click on Customer Change Notification and follow the registration instructions.

The Development Systems product group categories are:

- **Compilers** – The latest information on Microchip C compilers, assemblers, linkers and other language tools. These include all MPLAB C compilers; all MPLAB assemblers (including MPASM assembler); all MPLAB linkers (including MPLINK object linker); and all MPLAB librarians (including MPLIB object librarian).
- **Emulators** – The latest information on Microchip in-circuit emulators. This includes the MPLAB REAL ICE and MPLAB ICE 2000 in-circuit emulators.
- **In-Circuit Debuggers** – The latest information on the Microchip in-circuit debuggers. This includes MPLAB ICD 3 in-circuit debuggers and PICKit 3 debug express.
- **MPLAB IDE** – The latest information on Microchip MPLAB IDE, the Windows Integrated Development Environment for development systems tools. This list is focused on the MPLAB IDE, MPLAB IDE Project Manager, MPLAB Editor and MPLAB SIM simulator, as well as general editing and debugging features.
- **Programmers** – The latest information on Microchip programmers. These include production programmers such as MPLAB REAL ICE in-circuit emulator, MPLAB ICD 3 in-circuit debugger and MPLAB PM3 device programmers. Also included are nonproduction development programmers such as PICSTART Plus and PIC-kit 2 and 3.

CUSTOMER SUPPORT

Users of Microchip products can receive assistance through several channels:

- Distributor or Representative
- Local Sales Office
- Field Application Engineer (FAE)
- Technical Support

Customers should contact their distributor, representative or field application engineer (FAE) for support. Local sales offices are also available to help customers. A listing of sales offices and locations is included in the back of this document.

Technical support is available through the web site at:

<http://www.microchip.com/support>

DOCUMENT REVISION HISTORY

Revisions	Section/Figure/Entry	Correction
DS50002800C (03-21-23)	Section Appendix A. "Schematics"	Updated the diagrams.
DS50002800B (07-24-19)	Section 2.2 "Kit Contents" and Section 2.3 "Quick Start"	Updated the sections. The 12V power supply is not included in the kit.
DS50002800A (09-12-18)	Initial release	

Chapter 1. Overview

1.1 INTRODUCTION

The EVB-USB7002 is a demonstration and evaluation platform that provides the necessary requirements and interface options for evaluating the USB7002, which is a 4-port High-Speed (HS) USB smart hub on a 4-layer RoHS-compliant Printed Circuit Board (PCB). This allows the user to gain an understanding of the product and accelerate the integration of the USB7002 into the user's design.

The EVB-USB7002 is compliant with the USB 2.0 HS, Full-Speed (FS), and Low-Speed (LS) USB signaling. The EVB-USB7002 is also compliant with USB 3.1 Gen1 on the upstream port and on downstream ports 1 and 2.

The evaluation platform supports four downstream ports: two Gen1 ports with Type-C connectors and two USB2.0 ports with Type-A connectors. The EVB-USB7002 platform also supports battery charging on all four downstream ports (maximum of 10A [see [Note 1](#)] at any one time). The EVB-USB7002 supports FlexConnect role reversal for any of the four downstream ports with the upstream port.

The EVB-USB7002 has four configurations for operation through internal default settings and supports custom configurations through SMBus or through the external 16-Mbit SPI Flash device.

The EVB-USB7002 demonstrates driver compatibility with Microsoft® Windows® 10, Windows 8.x, Windows 7, Windows XP, Mac OS® X 10.4+, and Linux® hub drivers.

For more information about EVB-USB7002, see [Section 1.2 "Features"](#).

Note 1: Requires a 12V, 85W supply.
--

1.2 FEATURES

- Microchip's PortSwap, PHYBoost™, and VariSense™ technologies
- USB7002 in a 100-pin QFN RoHS compliant package
- USB 3.1 compliant (Gen1 operation)
- USB 2.0 compliant (HS, FS, and LS operation)
- 5V-tolerant USB pins
- Self-powered operation
- USB Gen1 Type-C upstream port
- Four Downstream USB ports:
 - Two Type-C Gen1 downstream ports
 - Two Type-A USB 2.0-only downstream ports
- All downstream ports support individual port power and overcurrent sense.
- All downstream ports can be enabled for battery charging with the battery charging select shunts J1 and J20. (BC1.2 or SE1, 2.1A max per port)
- Onboard SPI Flash for external downloadable firmware
- Operates from a single voltage (+12.0V, regulated) external power supply
- Onboard 25 MHz crystal or oscillator input
- Single onboard +5.2V, 15A regulator

- Single onboard +3.3V, 0.5A regulator
- Single onboard +1.2V, 2A regulator
- Port Power LED indicators
- SPI Flash activity blue LED indicator
- Reset red LED indicator
- Green LED indicators for 5V, 3.3V, and 1.2V regulator outputs
- Terminal block connector for use with an external 12 VDC bench supply
- Barrel connector for use with a Microchip 12V power supply
- Removable or non-removable downstream ports options can be configured with select shunt on J17.
- Bridge peripheral functions:
 - USB-to-UART (CDC)
 - USB-to-I²S Audio Codec
 - USB-to-SMBus
 - USB-to-I²C

1.3 BLOCK DIAGRAM

Figure 1-1 shows the block diagram of EVB-USB7002.

FIGURE 1-1: EVB-USB7002 BLOCK DIAGRAM

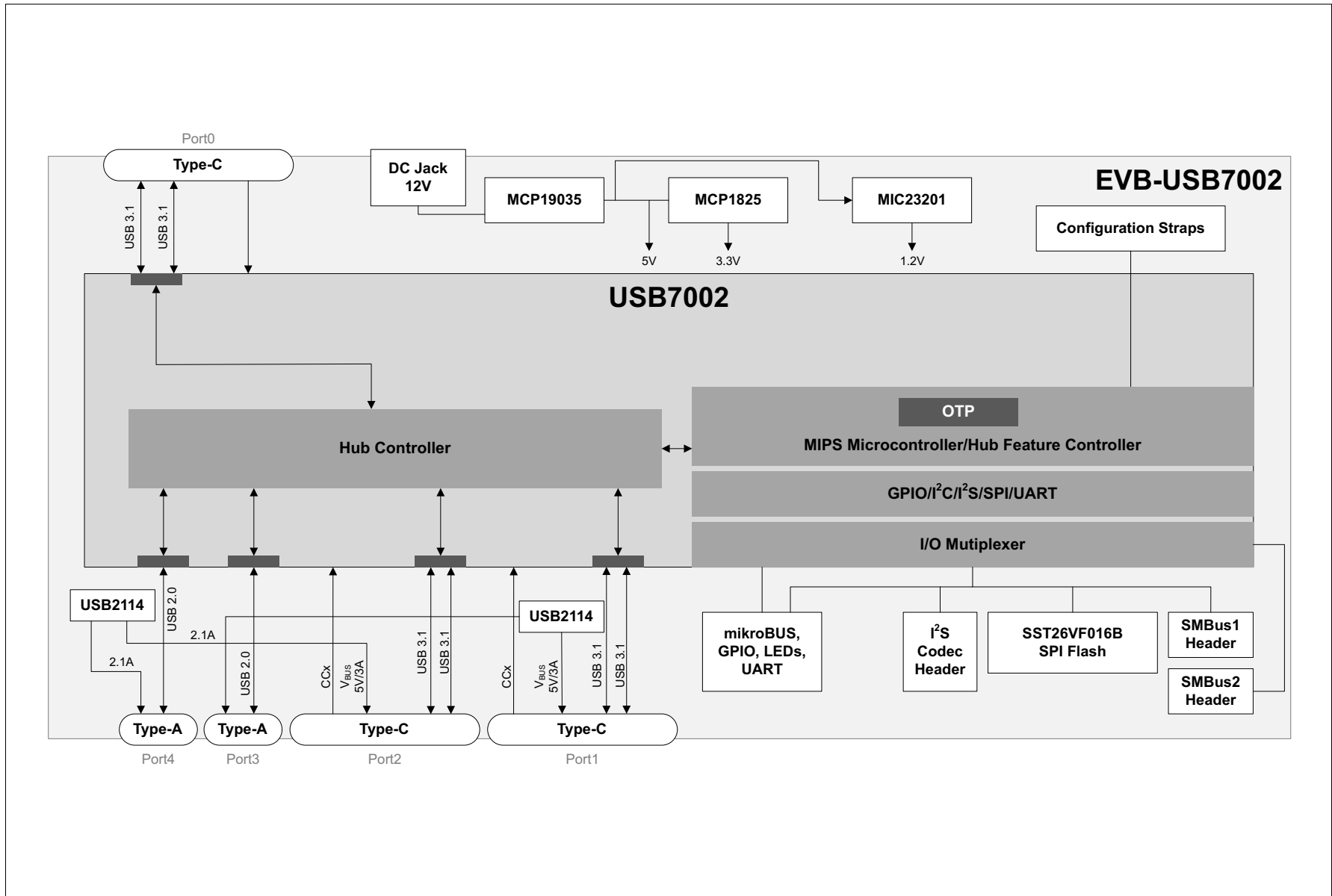

1.4 REFERENCES

Concepts and materials available in the following documents may be helpful when reading this document. Visit www.microchip.com for the latest documentation.

- *USB7002 Data Sheet*

1.5 ACRONYMS AND DEFINITIONS

TABLE 1-1: ACRONYMS AND DEFINITIONS

Acronym	Definition
BC1.2	Latest USB-IF specified USB battery charging standard
CDP	Charging Downstream Port, a BC1.2-compliant port allows simultaneous USB data and USB charging
DCP	Dedicated Charging Port, a BC1.2-compliant port which is only capable of USB charging (no data)
DFP	Downstream Facing Port
EVB	Evaluation Board
OTP	One-Time-Programmable Memory
SDP	Standard Downstream Port, a standard USB port with no high-current battery charging capabilities
SE1	Type of Battery Charging (non-USB compliant) that sets the USB D+/D- to specific DC voltages to communicate charging capability
Type-C	Reversible USB Connector
USB-IF	USB Integrators Forum, a collection of corporate sponsored members responsible for developing USB specifications
Gen1	USB Specification 3.1 Gen1

Chapter 2. Getting Started

2.1 INTRODUCTION

The Microchip EVB-USB7002 is designed for flexible configuration solutions. It can be configured via default internal register settings, via a downloadable external firmware to an onboard SPI Flash (OTP memory), via SMBus, or via the onboard configuration switches. When configured with the default internal register settings, the device operates as a USB 3.1 Gen1 hub with one upstream Gen1 port, two downstream Gen2 ports, and two downstream USB 2.0 ports, with Microchip's standard VID/PID/DID settings.

Microchip provides a comprehensive software programming tool, MPLAB® Connect (MPLABC), for configuring USB7002 functions, registers, and OTP memory. USB7002 requires MPLABC version 2.1.0 or greater.

For additional information on the MPLABCC programming tool, refer to Software Libraries within the Microchip USB7002 product page at www.microchip.com/USB7002.

2.2 KIT CONTENTS

The EVB-USB7002 Evaluation Kit includes the basic equipment necessary for evaluation. The items included in the kit are:

- EVB-USB7002 Evaluation Board
- Type-A to Type-C USB cable

2.3 QUICK START

To quickly start using the board, perform the following steps:

1. Connect a 12V power supply to the barrel connector (J1) or the terminal block (J2) on the EVB-USB7002.
2. Using a Type-A to Type-C USB cable, connect the EVB-USB7002 to a USB host via the upstream "Port 0" USB Type-C socket (J3).

Devices may now be connected to any of the downstream ports to enumerate and use those devices with the USB host.

To perform additional configuration or evaluate specific features, launch the MPLABC software on your USB host or manipulate the included hardware configuration options detailed in the next sections.

EVB-USB7002 Evaluation Kit User's Guide

NOTES:

Chapter 3. Hardware Configuration

3.1 HARDWARE CONFIGURATION OPTIONS

Figure 3-1 shows the top view of the EVB-USB7002.

FIGURE 3-1: EVB-USB7002 REV B (TOP VIEW)

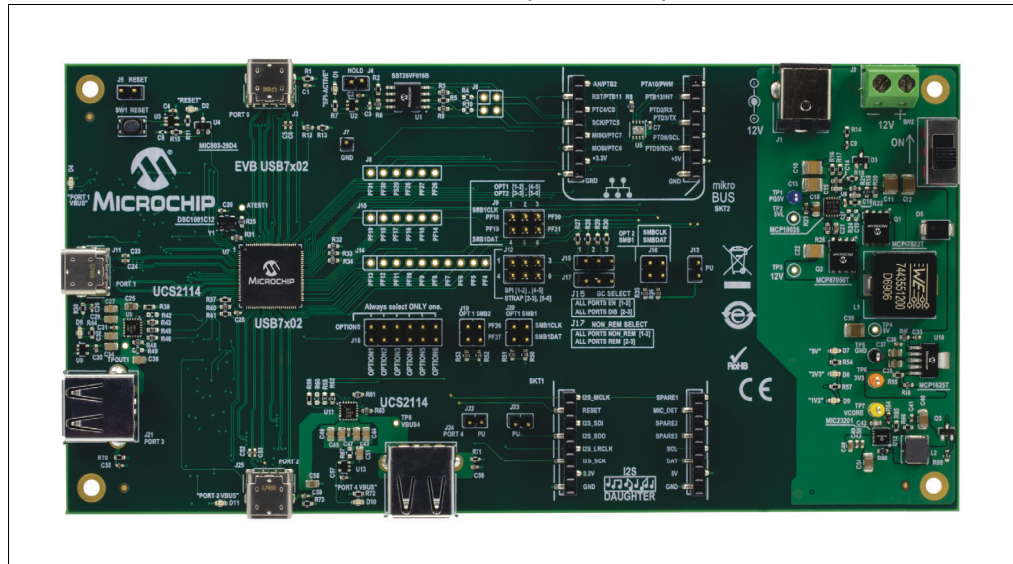

3.1.1 Configuration

3.1.1.1 EXTERNAL SPI FLASH

Upon power-up, the USB7002 first looks for an external SPI ROM device and a valid signature in the Flash. If one is found, the external ROM is enabled and code execution is initiated from the external SPI ROM device.

To enable operation from the SPI device, install shunts to pins 1-2 and 4-5 of J12. When code is executing from an SPI ROM device, a blue LED “SPI-ACTIVE” (D1) illuminates.

Note 1: CFG_BC and CFG_Non-Rem options are deselected when SPI shunts are installed on J17. When operating in SPI mode, all configuration is handled by the code executing from the SPI ROM device.

2: If the SPI Flash is not properly programmed or has an invalid signature, the USB7002 reverts to internal defaults even if the SPI ROM is selected.

3.1.1.2 SMBUS2

If an SPI Flash device is not found, the firmware checks if SMBus2 is enabled.

To select SMBus2 configuration, leave J17 open to disconnect the SPI ROM. To select OPTION1 from the CFG_STRAP header, shunt pins 1-2 of J18. To connect the SMBus2 pull-up resistors, connect a shunt to J22 pins 1-2. The SMBus2 signals may be accessed at J19, where pin 1 is the clock and pin 3 is data (pin 2 is ground).

If configuration OPTION1 is selected and SMBus2 is enabled (that is, SMBus2 clock and data are pulled up), the USB7002 waits indefinitely for data from the SMBus2 interface and will not enumerate to the USB host until the special USB Attach command is sent.

See the Configuration Options for USB70xx application note for additional details.

3.1.1.3 INTERNAL DEFAULT CONFIGURATIONS WITH STRAPPING OPTIONS

When the USB7002 does not detect a valid SPI Flash image and does not look for SMBus2 configuration upon power-up, the USB7002 uses internal default register settings. It also sets the Vendor ID, Product ID, Language ID, and Device ID, and additional settings from the internal ROM code.

If configuration is not done through SPI or SMBus2, additional configuration is available through two functions: CFG_BC_EN and CFG_NON-REM. The controls are configured by selecting one of the six resistor values for each pin. The EVB-USB7002 demonstrates two of the six possible resistor values for each of CFG_BC_EN and CFG_NON-REM. These straps are sensed by the USB7002 device at power-on to determine the resultant configuration of the device.

To select the CFG_BC_EN and CFG_NON-REM modes, shunts must be connected to J12, J15, and J17 headers.

To use the battery charging strap options, connect a shunt to pins 2-3 of J12 and connect a shunt to J15 according to [Table 3-1](#). For the NON_REM strap options, connect a shunt to pins 5-6 of J12 and connect a shunt to J17 according to [Table 3-2](#).

TABLE 3-1: BATTERY CHARGING OPTIONS (CFG_BC_EN - J15)

J15 Shunt Position	(J12 is shunted pins 2-3.)
2-3	All ports are BC 1.2-disabled.
1-2	All downstream ports are BC1.2-enabled.

TABLE 3-2: NON-REMOVABLE PORT OPTIONS (CFG_NON-REM - J17)

J17 Shunt Position	(J12 is shunted pins 5-6.)
1-2	All ports are non-removable.
2-3	All ports are removable.

3.1.2 Power Source - Self Powered

The EVB-USB7002 only supports self-powered operation. Power is supplied through one +12.0V regulated external power supply. The power supply is connected to the 2.5 mm connector J1 on the board. Alternatively, an external voltage can be supplied to the screw terminal “12V” (J2). The +12.0V feeds a 15A regulator that outputs +5.2V (nominal) across the board and also supplies the +3.3V regulator and the 1.2V regulator.

CAUTION

The supplied 12.0V external power supply cannot support simultaneous battery charging on all downstream ports. Use a higher power supply if the required test use case exceeds the power capability of the supply. Failure to heed to this warning could result in damage to the 12.0V external power supply.

3.1.3 Downstream Port Power Control

USB power to the four downstream ports is controlled via port power controllers with auto-discharge functionality. All downstream ports support BC 1.2 battery charging.

The two downstream USB Type-C ports are each capable of up to 3A of current at 5V. The two downstream USB Type-A ports are capable of up to 2.1A at 5V.

3.1.4 USB Type-C Ports

The USB7002 has two USB3.1 Gen 1 PHYs for each Type-C port. This eliminates the need for an external multiplexer. The USB7002 also features integrated Type-C control signal (CC) detection to determine when and in what orientation a USB Type-C attach has been made. It powers only the USB3.1 Gen 1 PHY needed for USB communication. To reduce power, the USB7002 powers down unused USB3.1 Gen 1 PHYs. In the case where no USB Type-C attach is detected, both USB3.1 Gen 1 PHYs associated with that port are powered down.

3.1.5 LED Indicators

Table 3-3 describes the LED indicators on the EVB-USB7002.

TABLE 3-3: EVB-USB7002 LED INDICATOR DESCRIPTIONS

Ref. Des.	Label	Description
D1	“SPI-ACTIVE”	Indicates SPI Flash Memory activity.
D2	“RESET”	The RST_N signal is asserted.
D4	“PORT 1 VBUS”	Illuminates when 5V to upstream PORT1 VBUS is present.
D6	“PORT 3 VBUS”	Illuminates when 5V to upstream PORT3 VBUS is present.
D7	“5V”	Illuminates when 5V is present from the 5V voltage regulator.
D8	“3V3”	Illuminates when 3.3V is present from the 3.3V voltage regulator.
D9	“VCORE”	Illuminates when 1.2V (VCORE) is present from the 1.2V regulator.
D10	“PORT 4 VBUS”	Illuminates when 5V to upstream PORT4 VBUS is present.
D11	“PORT 2 VBUS”	Illuminates when 5V to upstream PORT2 VBUS is present.
D14	“ATTACH2”	Illuminates when a device is detected by CC signals on PORT2.

3.1.6 Switches

Table 3-4 describes the switches on the EVB-USB7002.

TABLE 3-4: EVB-USB7002 SWITCH DESCRIPTIONS

Ref. Des.	Label	Description
SW1	"RESET"	Momentary push-button switch to assert RST_N.
SW2	"ON/OFF"	Connects or disconnects the 12 VDC supply.

3.1.7 Connector Descriptions

Table 3-5 describes the connectors included on the PCB.

TABLE 3-5: EVB-USB7002 CONNECTOR DESCRIPTIONS

Ref. Des.	Type	Label	Description
J1	Barrel Jack	"12VDC"	12 VDC supply connection (center pin positive)
J2	2-pin terminal block	—	Alternative 12 VDC supply connection. Pin 1 is positive.
J3	USB Type-C Connector	"PORT0"	Upstream Type-C connection
J4	1x2 Header	"HOLD"	When shunted, disables the SPI memory.
J1	2x3 Header	"SPI_DI/CFG_BC_EN" "SPI_CEn/CFG_NON_REM"	Selects between SPI memory capability and BC/NON_REM capability. For SPI, connect pins 2-3 and 5-6. For BC, connect pins 4-5. For NON_REM, connect pins 1-2.
J5	2x1 Header	"Ext.Reset"	Connection for an external reset switch
J6	2x2 Header	PF24 PF23 PF25 PF21	SPI data pins provided for debugging SPI memory
J7	1x1 Header	"GND"	Circuit Ground
J8	1x6 Header	—	PF26 - PF31
J9	2x3 Header	"SMBus1"	OPTION1: 1-2 and 4-5 connects SMBus1 OPTION2: 2-3 and 5-6 connects SMBus1
J10	1x6 Header	—	PF14 - PF19
J11	USB Type-C Connector	"PORT1"	Downstream Type-C Gen1 Port 1 USB connection
J12	2x3 Header	"SPI/BC/NR"	SPI_DI or CFG_BC_EN SPI_CEn or CFG_NON_REM See Table 3-1 and Table 3-2.
J13	1x2 Header	"PU"	Pull-up resistors, OPTION2 SMBus2
J14	1x10 Header	—	PF4 - PF13
J15	1x3 Header	"BC SELECT"	See Table 3-1.
J16	2x2 Header	"OPTION2 SMB1"	Access to SMBus1 in OPTION2
J17	1x3 Header	"NON_REM_SELECT"	See Table 3-2.

TABLE 3-5: EVB-USB7002 CONNECTOR DESCRIPTIONS (CONTINUED)

Ref. Des.	Type	Label	Description
J18	2x6 Header	“CFG_SELECT”	Configuration Option select. Always select 1 and only 1 option.
J19	2x2 Header	“OPTION1 SMB2”	Access to SMBus2 in OPTION1
J20	2x2 Header	“OPTION1 SMB1”	Access to SMBus1 in OPTION1
J21	USB2 Type-A Connector	“PORT3”	Downstream Port 3 USB connection
J22	1x2 Header	“PU”	Pull-up resistors, OPTION1 SMBus2
J23	1x2 Header	“PU”	Pull-up resistors, OPTION1 SMBus1
J24	USB2 Type-A Connector	“PORT4”	Downstream Port 4 USB connection
J25	USB Type-C Connector	“PORT2”	Downstream Port 2 USB connection
J26	1x3 Header	—	Spares for future use

3.1.8 Test Points

Table 3-6 describes the test points on the EVB-USB7002. A header may be permanently installed on the through-hole test points if needed.

TABLE 3-6: EVB-USB7002 TEST POINT DESCRIPTIONS

Ref. Des.	Type	Description
TPOUT1	Test Pad	PORT3 VBUS
TP1	Test Loop (Blue)	Signal PG5V
TP2	Test Loop (Red)	Signal 5VL
TP3	Test Loop (Red)	12V
TP4	Test Loop (Red)	5V
TP5	Test Loop (Black)	Circuit Ground
TP6	Test Loop (Orange)	3.3V
TP7	Test Loop (Orange)	VCORE (1.2V)
TP8	Test Pad	PORT4 VBUS

EVB-USB7002 Evaluation Kit User's Guide

NOTES:



Appendix A. Schematics

A.1 INTRODUCTION

This appendix shows the EVB-USB7002 Evaluation Kit schematic.

FIGURE A-1: EVB-USB7002 USB7X02 PART A

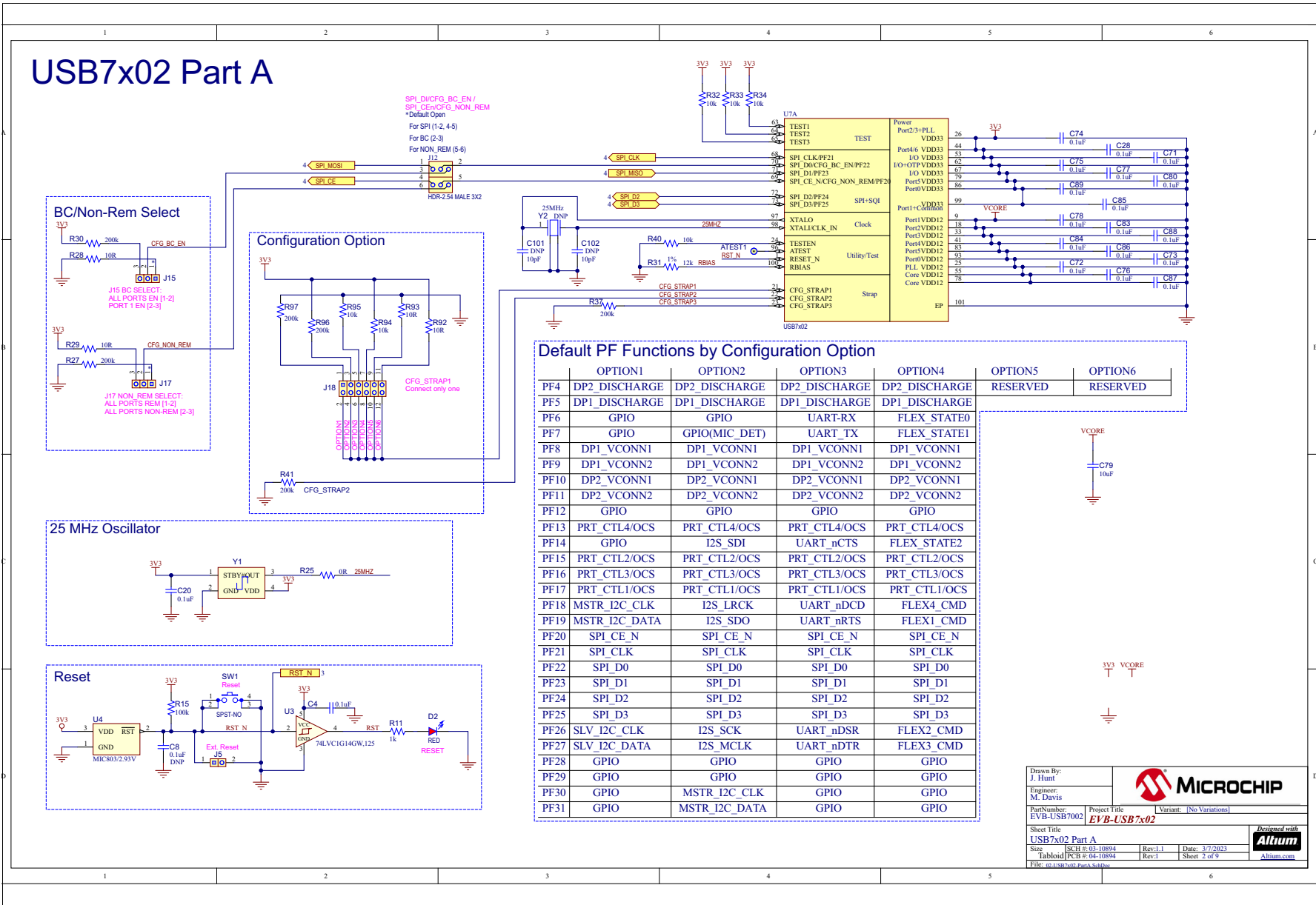

Drawn By: J. Hunt
 Engineer: M. Davis
 PartNumber: EVB-USB7002
 Project Title: EVB-USB7x02
 Variant: [No Variations]

MICROCHIP

Sheet Title: USB7x02 Part A
 Size: [SC-H # 01-10894] Rev: 1 Date: 3/7/2023
 Tabloid PCB #: 04-10894 Rev: 1 Sheet 2 of 9
 File: c:\source\usb7002\usb7x02.pcb

Designed with **Altium**

FIGURE A-2: EVB-USB7002 USB7X02 PART B AND AUDIO CODEC INTERFACE

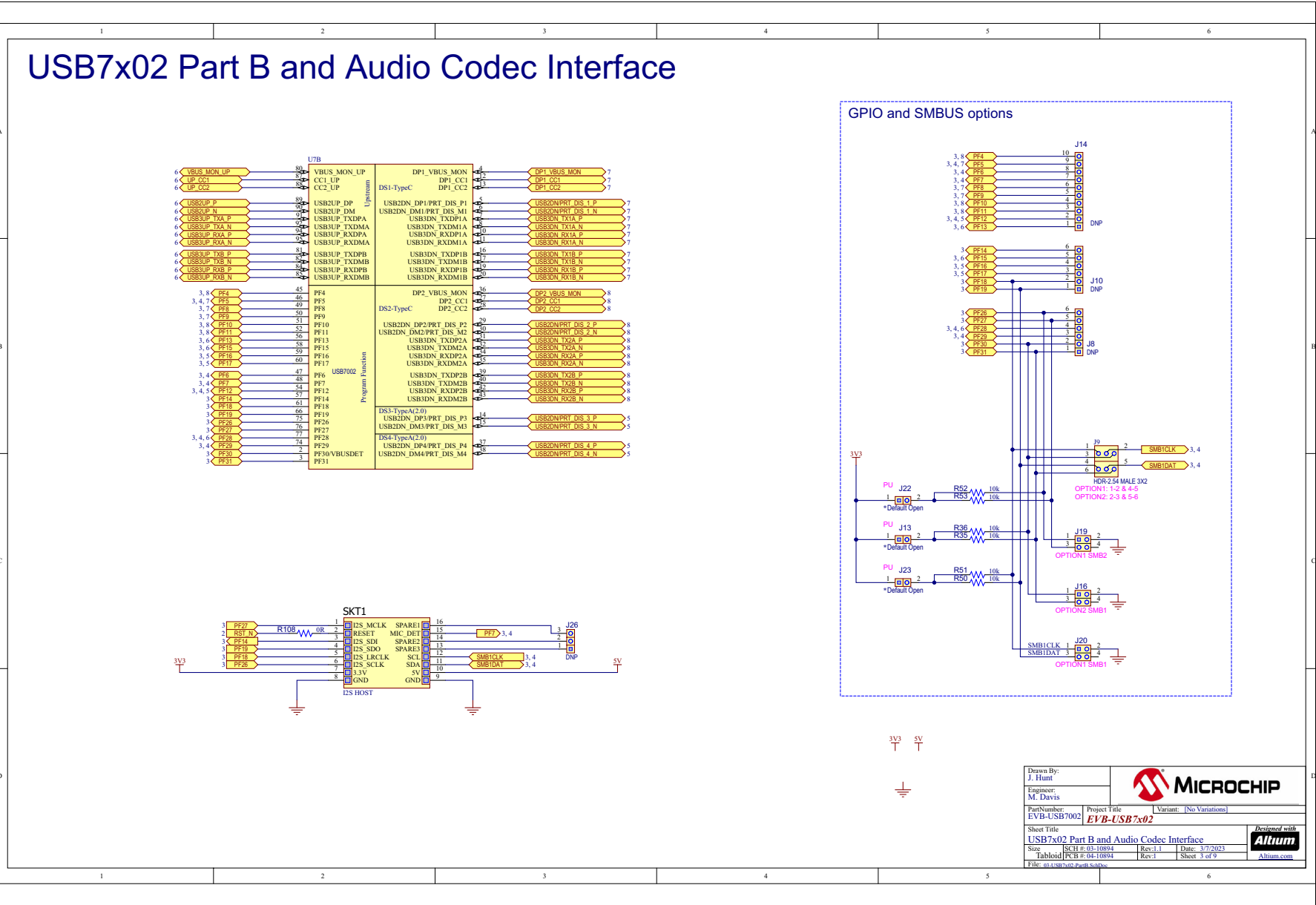
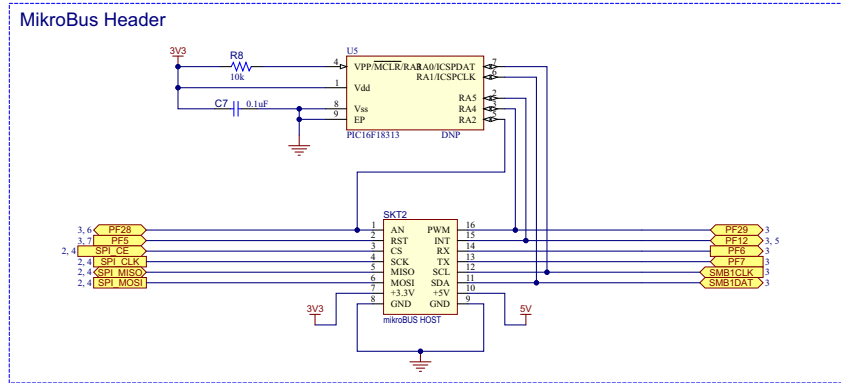
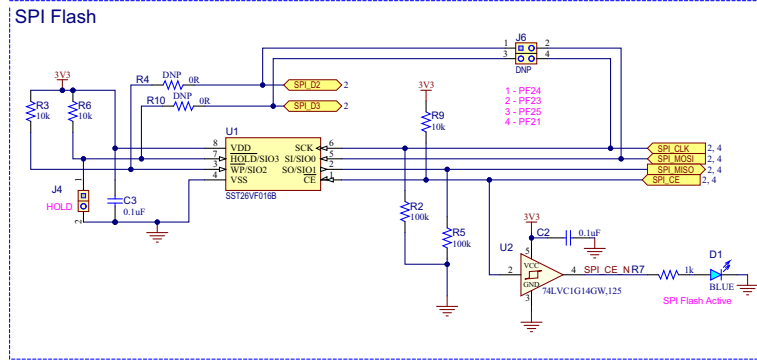

FIGURE A-3: EVB-USB7002 MEMORY AND MIKROBUS

Memory and MikroBUS



3V3
T

Drawn By: J. Hunt							
Engineer: M. Davis							
PartNumber: EVB-USB7002	Project Title EVB-USB7002 Variant: [No Variations]						
Sheet Title Memory and MikroBUS	Designed with 						
Size Tabloid	<table border="1"> <tr> <td>SC-H #: 03-10894</td> <td>Rev: 1.1</td> <td>Date: 3/7/2023</td> </tr> <tr> <td>PC-B #: 04-10894</td> <td>Rev: 1</td> <td>Sheet 4 of 9</td> </tr> </table>	SC-H #: 03-10894	Rev: 1.1	Date: 3/7/2023	PC-B #: 04-10894	Rev: 1	Sheet 4 of 9
SC-H #: 03-10894	Rev: 1.1	Date: 3/7/2023					
PC-B #: 04-10894	Rev: 1	Sheet 4 of 9					
File: atMemory_Sch.sch	Altium.com						

FIGURE A-5: EVB-USB7002 USB C UPSTREAM AND POWER SWITCH

USB C Upstream and Power Switch

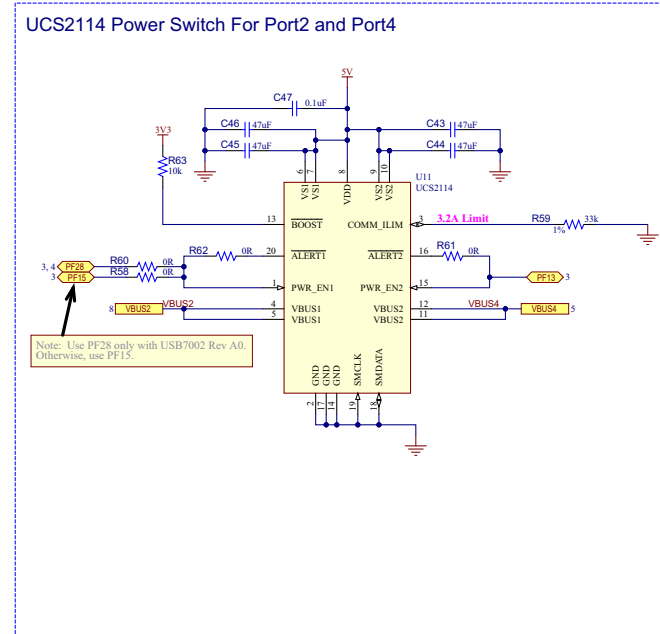
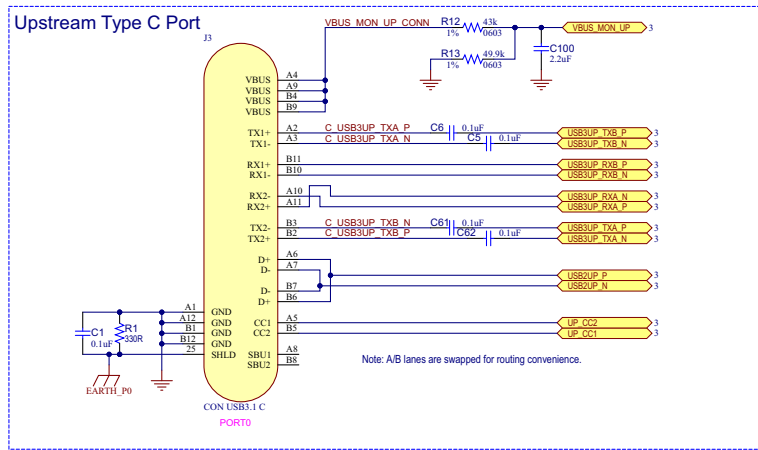

Drawn By: J. Hunt	
Engineer: M. Davis	
PartNumber: EVB-USB7002	Project Title EVB-USB7x02 Variant: [No Variations]
Sheet Title USB C Upstream and Power Switch	Designed with
Size Tabloid PCB # 04-10894	Rev: 1.1 Date: 3/7/2023
File: uc3201c_usbupsw02	Rev: 1 Sheet 6 of 9 Altium.com

FIGURE A-6: EVB-USB7002 USB C DOWNSTREAM 1

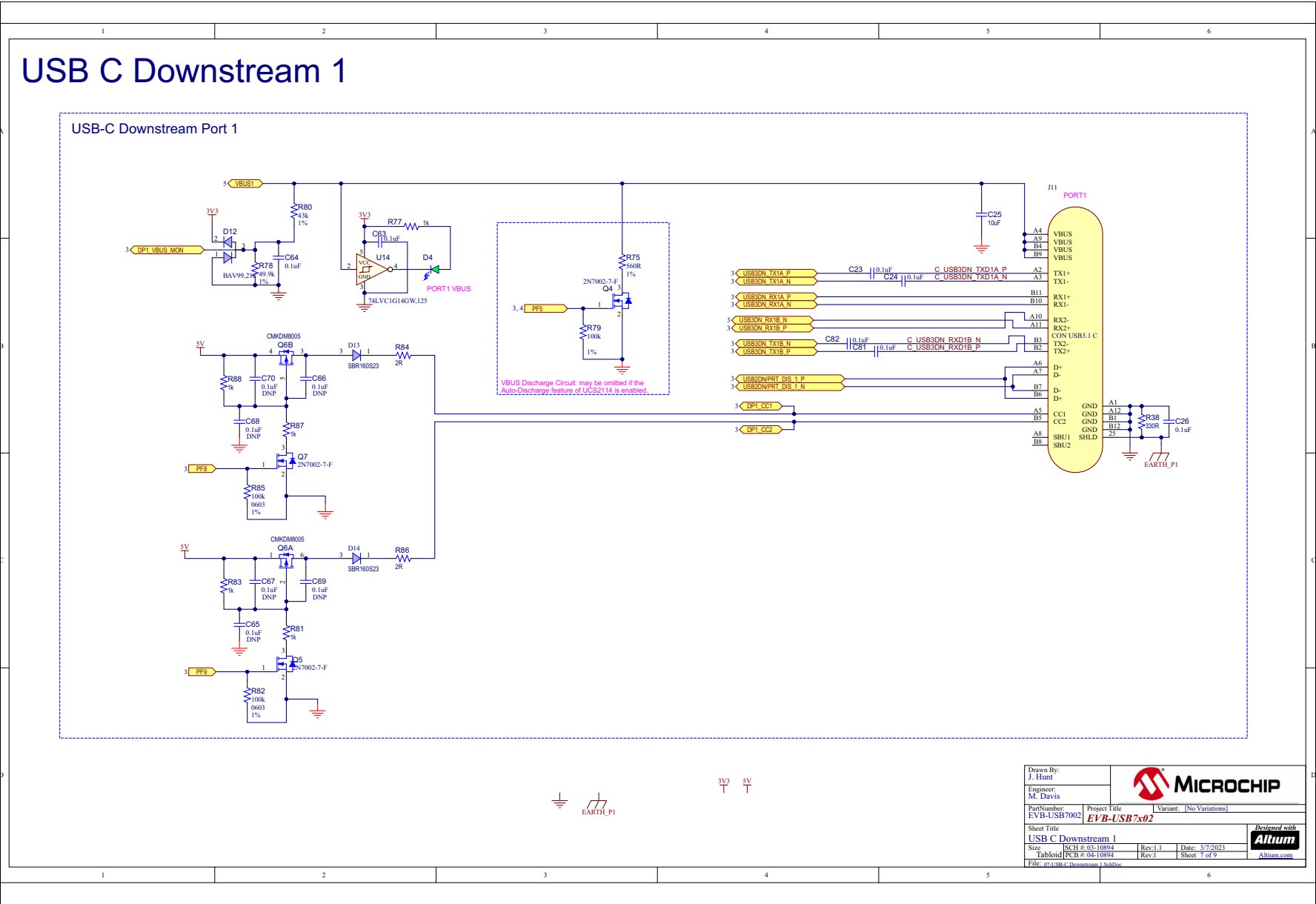

Drawn By: J. Hunt	MICROCHIP
Engineer: M. Davis	
Part Number: EVB-USB7002	Project Title: EVB-USB7x02
Variant: [No Variations]	
Sheet Title: USB C Downstream 1	
Size: SCH #: 03-10894	Rev: 1.1
TabId: PCB #: 04-10894	Rev: 1
Date: 3/7/2023	
Sheet 7 of 9	
Altium.com	

FIGURE A-7: EVB-USB7002 USB C DOWNSTREAM 2

USB C Downstream 2

USB-C Downstream Port 2

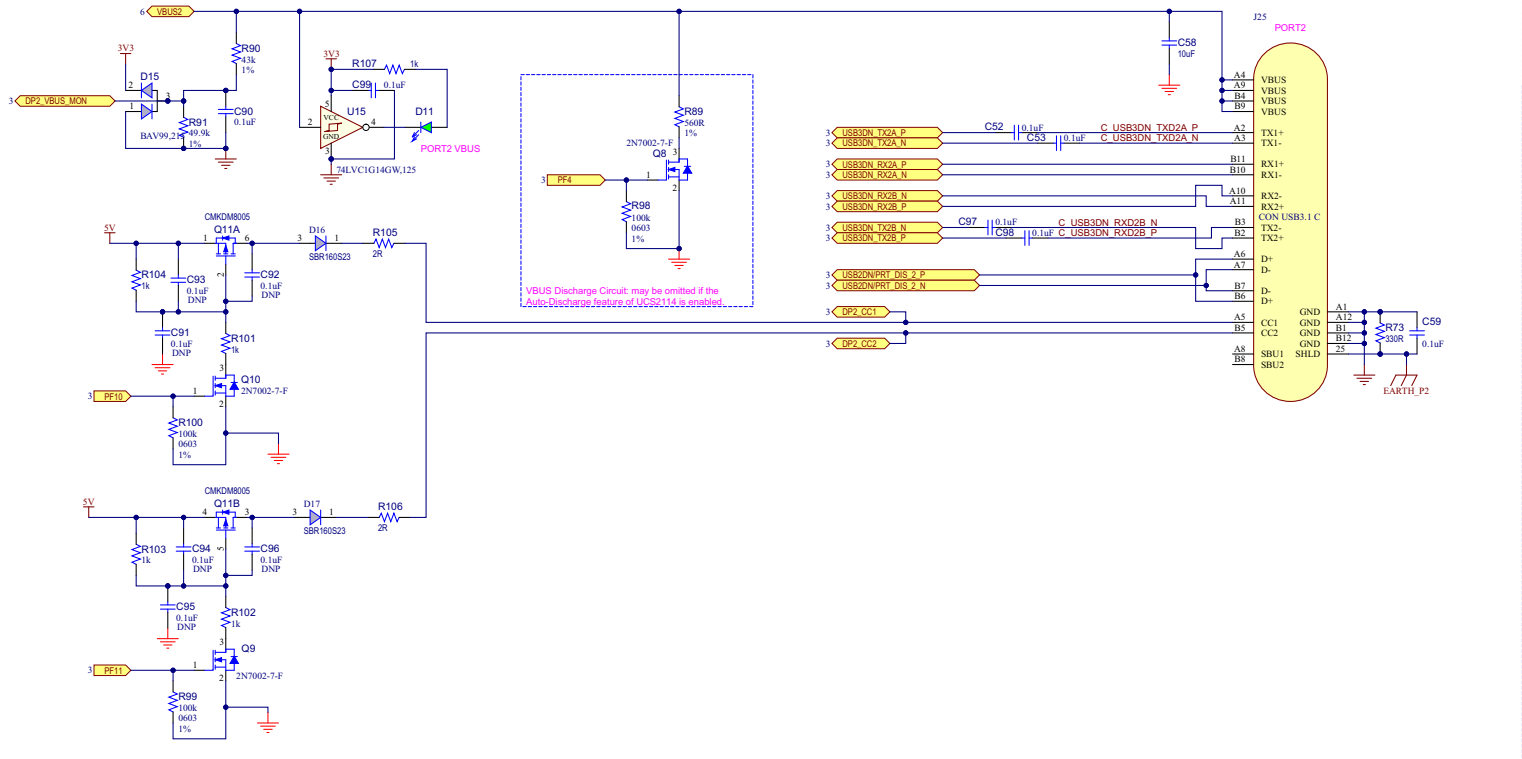

VBUS Discharge Circuit: may be omitted if the Auto-Discharge feature of UC597114 is enabled.



Drawn By: J. Hunt	
Engineer: M. Davis	
PartNumber: EVB-USB7002	Project Title EVB-USB7002 Variant: [No Variations]
Sheet Title USB C Downstream 2	Designed with
Size Tabloid PCB #: 04-10894	Rev: 1.1 Date: 3/7/2023
File: uc597114-C-Downstream 2-300.cad	Rev: 1 Sheet 8 of 9

FIGURE A-8: EVB-USB7002 VOLTAGE REGULATORS

Voltage Regulators

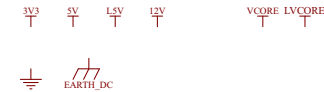
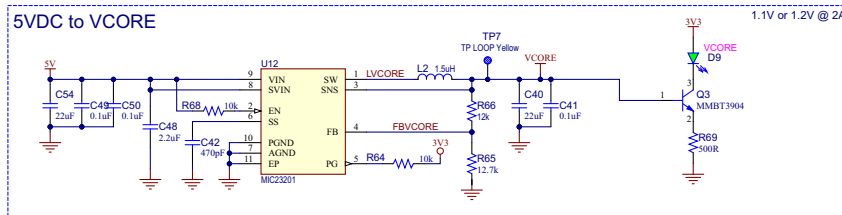
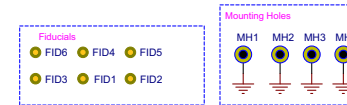
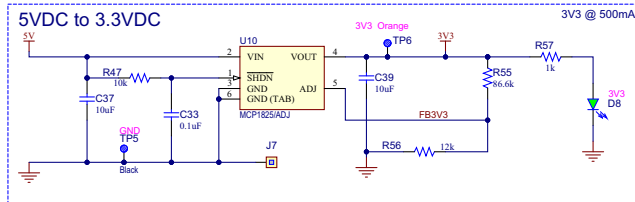
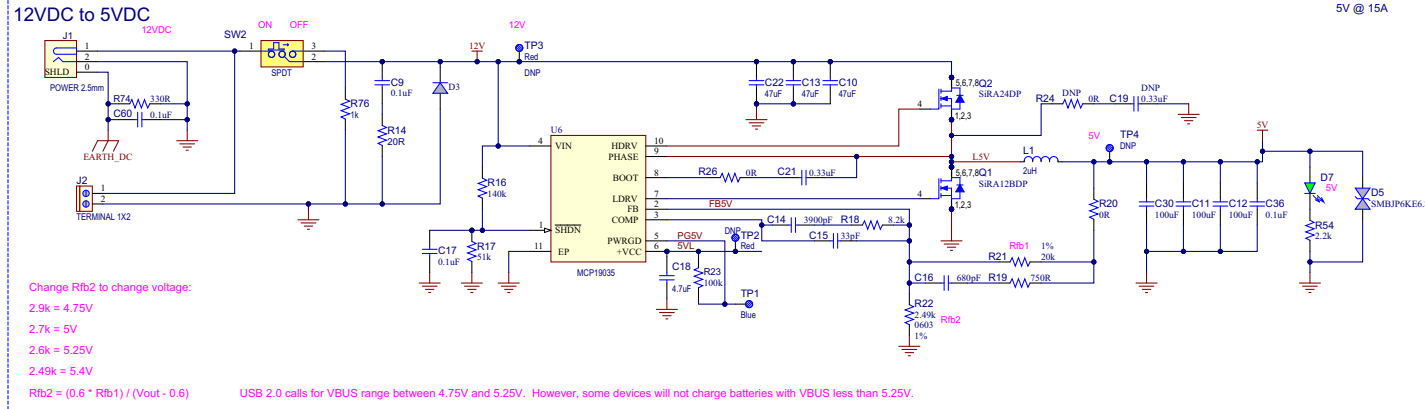

Drawn By: J. Hunt	MICROCHIP	
Engineer: M. Davis		
Part Number: EVB-USB7002	Project Title: EVB-USB7x02	Variant: [No Variations]
Sheet Title: Voltage Regulators		
Size: Tabloid	SCH #: 03-10894 PCB #: 04-10894	Rev: 1.1 Rev: 1
File: evb_usb_7002_v03.sch	Date: 3/7/2023	Sheet 9 of 9



NOTES:



Appendix B. Bill of Materials

B.1 INTRODUCTION

This appendix contains the EVB-USB7002 Evaluation Board Bill of Materials (BOM).

TABLE B-1: EVB-USB7002 BILL OF MATERIALS

Item	Quantity	Designator	Description	Populated	Manufacturer	Manufacturer Part Number
1	55	C1, C2, C3, C4, C5, C6, C7, C9, C17, C20, C23, C24, C26, C28, C31, C33, C35, C36, C41, C47, C49, C50, C52, C53, C55, C56, C57, C59, C60, C61, C62, C63, C64, C71, C72, C73, C74, C75, C76, C77, C78, C80, C81, C82, C83, C84, C85, C86, C87, C88, C89, C90, C97, C98, C99	CAP CER 0.1uF 16V 10% X7R SMD 0402	YES	Murata	GRM155R71C104KA88D
2	3	C10, C13, C22	CAP CER 47uF 16V 10% X5R SMD 1210	YES	Murata Electronics North America	GRM32ER61C476KE15K
3	3	C11, C12, C30	CAP CER 100uF 10V 20% X5R SMD 1210	YES	Taiyo Yuden	LMK325BJ107MM-T
4	1	C14	CAP CER 3900pF 50V 5% C0G SMD 0603	YES	TDK	C1608C0G1H392J080AA
5	1	C15	CAP CER 33pF 50V 5% NP0 SMD 0603	YES	Cal-Chip	GMC10CG330J50NTLF
6	1	C16	CAP CER 680pF 50V 5% NP0 SMD 0603	YES	Panasonic	ECJ-1VC1H681J
7	1	C18	CAP CER 4.7uF 35V 10% X7R SMD 0805	YES	TDK Corporation	C2012X7R1V475K125AC
8	1	C21	CAP CER 0.33uF 16V 10% X7R SMD 0603	YES	Murata	GRM188R71C334KA01D
9	5	C25, C37, C39, C58, C79	CAP CER 10uF 16V 10% X5R SMD 0805	YES	Wurth Electronics Inc	885012107014
10	10	C27, C29, C32, C34, C38, C43, C44, C45, C46, C51	CAP CER 47uF 6.3V 20% X5R SMD 0805	YES	Taiyo Yuden	JMK212BJ476MG-T
11	2	C40, C54	CAP CER 22uF 10V 10% X7R SMD 1206	YES	Samsung Electro-Mechanics America, Inc	CL31B226KPHNNNE
12	1	C42	CAP CER 470pF 25V 5% NP0 SMD 0603	YES	AVX	06033A471JAT2A
13	1	C48	CAP CER 2.2uF 10V 10% X7R SMD 0603	YES	Murata	GRM188R71A225KE15D
14	1	C100	CAP CER 2.2UF 16V X5R 0402	YES	TDK	TDK C1005X5R1C225K050BC
15	1	D1	DIO LED BLUE 2.8V 20mA 15mcd Clear SMD 0603	YES	Lite-On	LTST-C193TBKT-5A
16	1	D2	DIO RED 2V 20mA 54mcd CLEAR SMD 0603	YES	Lite-On Inc.	LTST-C191KRKT
17	1	D3	DIO RECT MMBD914-7-F 1.25V 200mA 75V SMD SOT-23-3	YES	Diodes Incorporated	MMBD914-7-F
18	7	D4, D6, D7, D8, D9, D10, D11	DIO LED GREEN 2V 30mA 35mcd Clear SMD 0603	YES	Lite-On Inc	LTST-C191KGKT
19	1	D5	DIO TVS SMBJP6KE6.8CA 5.8V 600W DO-214AA_SMB	YES	Micro Commercial Co	SMBJP6KE6.8CA-TP
20	2	D12, D15	DIO RECTARR BAV99 1.25V 200mA 70V SOT-23-3	YES	Fairchild	BAV99
21	4	D13, D14, D16, D17	DIO SBAR SBR160S23-7 SBR 530mV 900mA 60V SMD SOT23-3	YES	Diodes Incorporated	SBR160S23-7
22	1	J1	CON POWER 2.5mm 5.5mm TH R/A	YES	CUI Inc.	PJ-063BH
23	1	J2	CON TERMINAL 5.08mm 1X2 Female 16-30AWG 13.5A TH RA	YES	TE Connectivity	282836-2
24	3	J3, J11, J25	CON USB3.0 TYPE-C FEMALE SMD R/A	YES	Advanced-Connectek Inc.	NBR25-AK5322
25	5	J4, J5, J13, J22, J23	CON HDR-2.54 Male 1x2 Gold 5.84MH TH VERT	YES	FCI	77311-118-02LF

TABLE B-1: EVB-USB7002 BILL OF MATERIALS (CONTINUED)

Item	Quantity	Designator	Description	Populated	Manufacturer	Manufacturer Part Number
26	1	J7	CON HDR-2.54 Male 1x1 Gold 5.84MH TH VERT	YES	TE Connectivity	5-146280-1
27	2	J9, J12	CON HDR-2.54 Male 3x2 Gold 5.84MH TH VERT	YES	Samtec Inc.	TSW-102-07-G-T
28	2	J15, J17	CON HDR-2.54 Male 1x3 Gold 5.84MH TH VERT	YES	FCI	68000-103HLF
29	3	J16, J19, J20	CON HDR-2.54 Male 2x2 Gold 5.84MH TH VERT	YES	Samtec	TSW-102-07-G-D
30	1	J18	CON HDR-2.54 Male 2x6 Gold 5.84MH TH VERT	YES	Samtec	TSW-106-07-G-D
31	2	J21, J24	CON USB2.0 STD-A FEMALE TH R/A	YES	TE Connectivity AMP Connectors	292303-1
32	1	L1	INDUCTOR 2uH 23A 20% SMD L12.8W12.8H6.2	YES	Wurth Electronics Inc.	7443551200
33	1	L2	INDUCTOR 1.5uH 3A 20% SMD L5W5H2.2	YES	Murata Electronics North America	LQH5BPN1R5NT0L
34	1	Q3	TRANS BJT NPN MMBT3904 40V 200mA 310mW SOT-23-3	YES	Diodes Incorporated	MMBT3904-7
35	6	Q4, Q5, Q7, Q8, Q9, Q10	TRANS FET N-CH 2N7002-7-F 60V 170mA 370mW SOT-23-3	YES	Diodes Inc	2N7002-7-F
36	2	Q6, Q11	TRANS FET DUAL P+P CMKDM8005 20V 650mA .360R 0.350W SOT-363	YES	Central Semiconductor Corp	CMKDM8005 TR
37	6	R1, R38, R70, R71, R73, R74	RES TKF 330R 1% 1/10W SMD 0603	YES	Panasonic	ERJ-3EKF3300V
38	9	R2, R5, R15, R79, R82, R85, R98, R99, R100	RES TKF 100k 1% 1/10W SMD 0603	YES	Panasonic	ERJ-3EKF1003V
39	19	R3, R6, R8, R9, R32, R33, R34, R35, R36, R40, R47, R48, R50, R51, R52, R53, R63, R94, R95	RES TKF 10k 1% 1/10W SMD 0603	YES	ROHM	MCR03EZPFX1002
40	14	R7, R11, R44, R57, R72, R76, R77, R81, R83, R87, R88, R101, R104, R107	RES TKF 1k 1% 1/10W SMD 0603	YES	Panasonic	ERJ-3EKF1001V
41	3	R12, R80, R90	RES TKF 43k 1% 1/10W SMD 0603	YES	Yageo	9C06031A4302FKHFT
42	3	R13, R78, R91	RES TKF 49.9k 1% 1/10W SMD 0603	YES	Panasonic	ERJ-3EKF4992V
43	1	R14	RES TKF 20R 1% 1/10W SMD 0603	YES	Panasonic	ERJ-3EKF20R0V
44	1	R16	RES TKF 140k 1% 1/10W SMD 0603	YES	Panasonic	ERJ-3EKF1403V
45	1	R17	RES TKF 51k 1% 1/10W SMD 0603	YES	Panasonic	ERJ-3EKF5102V
46	1	R18	RES TKF 8.2k 1% 1/10W SMD 0603	YES	Panasonic	ERJ-3EKF8201V
47	1	R19	RES TKF 750R 1% 1/10W SMD 0603	YES	Vishay	CRCW0603750RFKEA
48	2	R20, R26	RES TKF 0R 1/10W SMD 0603	YES	NIC Components	NRC06Z0TRF
49	1	R21	RES TKF 20k 1% 1/10W SMD 0603	YES	Yageo	9C06031A2002FKHFT
50	1	R22	RES TKF 2.49k 1% 1/10W SMD 0603	YES	Panasonic	ERJ-3EKF2491V
51	1	R23	RES TF 100k 1% 1/8W SMD 0603	YES	Vishay	MCT06030C1003FP500
52	8	R25, R42, R43, R46, R60, R61, R62, R108	RES TKF 0R 1/10W SMD 0603	YES	Panasonic	ERJ-3GSY0R00V
53	6	R27, R30, R37, R41, R96, R97	RES TKF 200k 1% 1/10W SMD 0603	YES	Panasonic	ERJ-3EKF2003V

TABLE B-1: EVB-USB7002 BILL OF MATERIALS (CONTINUED)

Item	Quantity	Designator	Description	Populated	Manufacturer	Manufacturer Part Number
54	4	R28, R29, R92, R93	RES TKF 10R 1% 1/10W SMD 0603	YES	Panasonic	ERJ-3EKF10R0V
55	2	R31, R56	RES TKF 12k 1% 1/10W SMD 0603	YES	Yageo	RC0603FR-0712KL
56	2	R39, R59	RES TKF 33k 1% 1/10W SMD 0603	YES	Panasonic	ERJ-3EKF3302V
57	1	R54	RES TKF 2.2k 1% 1/10W SMD 0603	YES	Panasonic	ERJ-3EKF2201V
58	1	R55	RES TKF 86.6k 1% 1/10W SMD 0603	YES	Panasonic Electronic Components	ERJ-3EKF8662V
59	2	R64, R68	RES TKF 10k 1% 1/10W SMD 0603	YES	Vishay	CRCW060310K0FKEA
60	1	R65	RES TKF 13k 1% 1/10W SMD 0603	YES	Panasonic	ERJ-3EKF1302V
61	1	R66	RES TKF 12.1k 1% 1/10W SMD 0603	YES	Panasonic	ERJ-3EKF1212V
62	1	R69	RES TKF 500R 5% 1/10W SMD 0603	YES	Stackpole Electronics Inc	RMC 1/16 500 5% R
63	2	R75, R89	RES TKF 560R 1% 1/10W SMD 0603	YES	Yageo	RC0603FR-07560RL
64	4	R84, R86, R105, R106	RES TKF 2R 1% 1/4W SMD 0603	YES	Vishay Dale	CRCW06032R00FKEAHP
65	2	R102, R103	RES TKF 1k 1% 1/16W SMD 0603	YES	MULTICOMP	MC0063W060311K
66	2	SKT1	SOCKET I2S HOST DIP 16 TH	YES	3M	963108-2000-AR-PR
67	2	SKT2	SOCKET mikroBUS HOST DIP 16 TH	YES	3M	963108-2000-AR-PR
68	1	SW1	SWITCH TACT SPST 16V 50mA PTS810 SJM 250 SMTR LFS SMD	YES	C&K Components	PTS810 SJM 250 SMTR LFS
69	1	SW2	SWITCH SLIDE SPDT 120V 6A 1101M2S3CQE2 TH	YES	C&K Components	1101M2S3CQE2
70	1	TP1	CON TP LOOP BLUE Ag TH	YES	Keystone Electronics	5117
71	1	TP5	MISC, TEST POINT MULTI PURPOSE MINI BLACK	YES	Keystone	5001
72	1	TP6	CON TP LOOP Orange TH	YES	Keystone Electronics	5003
73	1	TP7	MISC, TEST POINT PC MINI, 0.040" D YELLOW	YES	Keystone	5004
74	6	U2, U3, U9, U13, U14, U15	74LVC1G14GW,125 SCHMITT-TRG INVERTER	YES	NXP	74LVC1G14GW,125
75	1	Q1	MCHP ANALOG MOSFET N-CH 25V 100A 0.0026R MCP87022T-U/MF PDFN-8	YES	Microchip Technology	MCP87022T-U/MF
76	1	Q2	MCHP ANALOG MOSFET N-CH 25V 100A 0.006R MCP87050-U/MF PDFN-8	YES	Microchip	MCP87050T-U/MF
77	1	U1	MCHP MEMORY SERIAL FLASH 16M 104MHz SST26VF016B-104I/SM SOIJ-8	YES	Microchip Technology	SST26VF016B-104I/SM
78	1	U4	MCHP ANALOG SUPERVISOR 2.93V MIC803-29D4VM3-TR SOT-23-3	YES	Microchip Technology	MIC803-29D4VM3-TR
79	1	U6	MCHP ANALOG PWM CONTROLLER 600kHz MCP19035-BAABE/MF DFN-10	YES	Microchip	MCP19035-BAABE/MF
80	1	U7	MCHP INTERFACE USB 3.1 TYPE-C HUB CTLR TQFN-100	YES	Microchip Technology	USB7002/KDX
81	2	U8, U11	MCHP INTERFACE USB Power Controller UCS2114 QFN-20	YES	Microchip	UCS2114-1-V/LX
82	1	U10	MCHP ANALOG LDO ADJ MCP1825T-ADJE/DC SOT-223-5	YES	Microchip	MCP1825T-ADJE/DC
83	1	U12	MCHP ANALOG SWITCHER Buck 0.95V to 3.6V 2A MIC23201YML-TR MLF-10	YES	Microchip Technology	MIC23201YML-TR

TABLE B-1: EVB-USB7002 BILL OF MATERIALS (CONTINUED)

Item	Quantity	Designator	Description	Populated	Manufacturer	Manufacturer Part Number
84	1	Y1	MCHP CLOCK OSCILLATOR SINGLE 25MHZ DSC1001-CI2-025.0000T CDFN-4	YES	Microchip Technology	DSC1001CI2-025.0000T
85	13	C8, C65, C66, C67, C68, C69, C70, C91, C92, C93, C94, C95, C96	CAP CER 0.1uF 16V 10% X7R SMD 0402	DNP	Murata	GRM155R71C104KA88D
86	1	C19	CAP CER 0.33uF 16V 10% X7R SMD 0603	DNP	Murata	GRM188R71C334KA01D
87	2	C101, C102	CAP CER 10pF 50V 5% NP0 SMD 0402	DNP	Murata	GRM1555C1H100JZ01D
88	1	J6	CON HDR-2.54 Male 2x2 Gold 5.84MH TH VERT	DNP	Samtec	TSW-102-07-G-D
89	2	J8, J10	CON HDR-2.54 Male 1x6 Tin 5.84MH TH VERT	DNP	Sullins	PEC06SAAN
90	1	J14	CON HDR-2.54 Male 1x10 Gold 5.84MH TH VERT	DNP	Greenconn	GPHA101-1002A001B1BA
91	1	J26	CON HDR-2.54 Male 1x3 Gold 5.84MH TH VERT	DNP	FCI	68000-103HLF
92	3	R4, R10, R24	RES TKF 0R 1/10W SMD 0603	DNP	Panasonic	ERJ-3GSY0R00V
93	2	R45, R58	RES TKF 0R 1/10W SMD 0603	DNP	Panasonic	ERJ-3GSY0R00V
94	2	R49, R67	RES TKF 1k 1% 1/10W SMD 0603	DNP	Panasonic	ERJ-3EKF1001V
95	3	TP2, TP3, TP4	MISC, TEST POINT MULTI PURPOSE MINI RED	DNP	Keystone	5000
96	1	U5	MCHP MCU 8-BIT 32MHz 3.5kB 256B PIC16F18313-I/RF UDFN-8	DNP	Microchip	PIC16F18313-I/RF
97	1	Y2	Crystal 25MHz 4 pins 3225	DNP	Abracon	ABM8G-25.000MHZ-B4YT

NOTES:

FIGURE C-2: EVB-USB7002 BOTTOM SILK SCREEN IMAGE

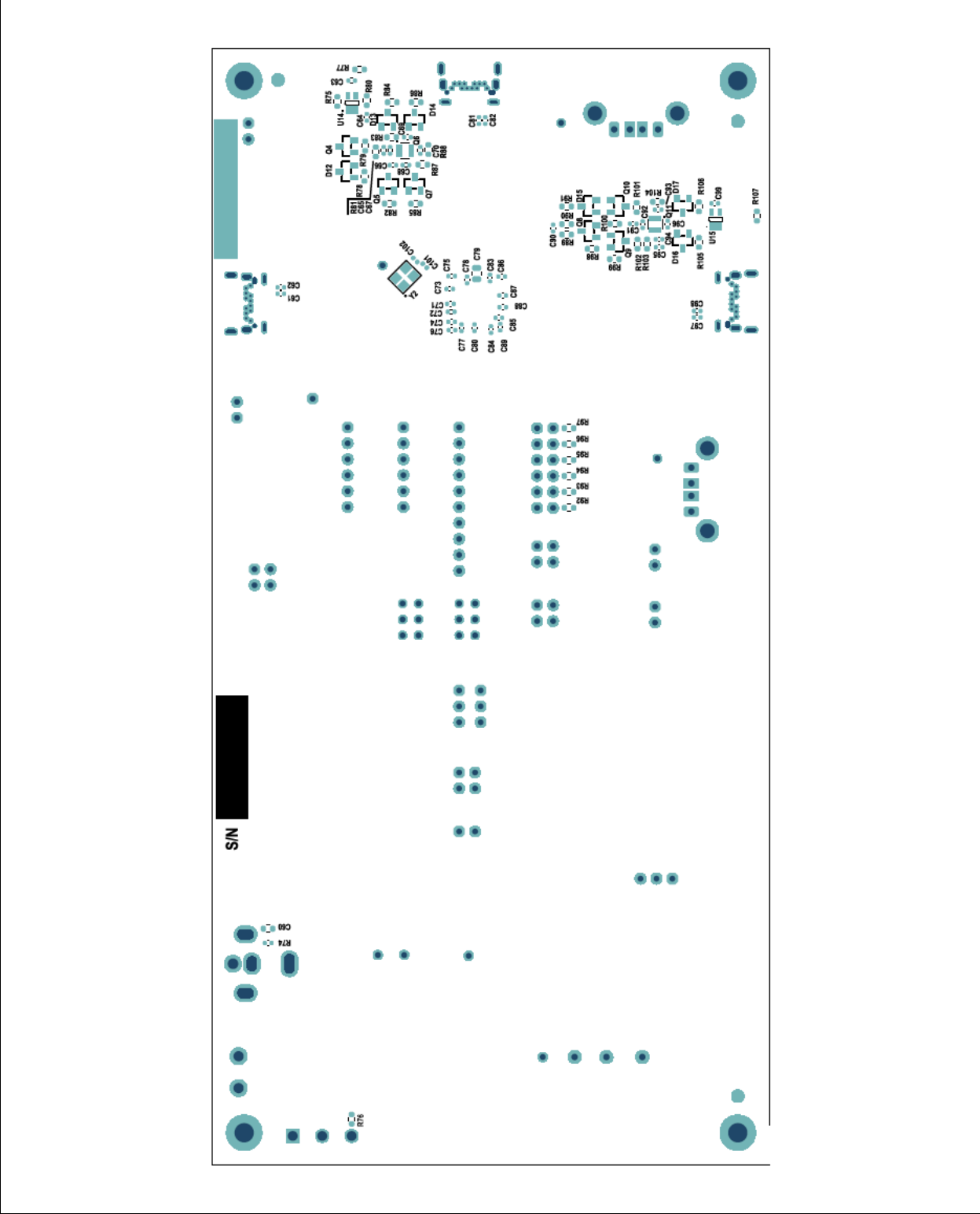

NOTES:



MICROCHIP

Worldwide Sales and Service

AMERICAS

Corporate Office
2355 West Chandler Blvd.
Chandler, AZ 85224-6199
Tel: 480-792-7200
Fax: 480-792-7277
Technical Support:
<http://www.microchip.com/support>
Web Address:
www.microchip.com

Atlanta

Duluth, GA
Tel: 678-957-9614
Fax: 678-957-1455

Austin, TX

Tel: 512-257-3370

Boston

Westborough, MA
Tel: 774-760-0087
Fax: 774-760-0088

Chicago

Itasca, IL
Tel: 630-285-0071
Fax: 630-285-0075

Dallas

Addison, TX
Tel: 972-818-7423
Fax: 972-818-2924

Detroit

Novi, MI
Tel: 248-848-4000

Houston, TX

Tel: 281-894-5983

Indianapolis

Noblesville, IN
Tel: 317-773-8323
Fax: 317-773-5453
Tel: 317-536-2380

Los Angeles

Mission Viejo, CA
Tel: 949-462-9523
Fax: 949-462-9608
Tel: 951-273-7800

Raleigh, NC

Tel: 919-844-7510

New York, NY

Tel: 631-435-6000

San Jose, CA

Tel: 408-735-9110
Tel: 408-436-4270

Canada - Toronto

Tel: 905-695-1980
Fax: 905-695-2078

ASIA/PACIFIC

Australia - Sydney
Tel: 61-2-9868-6733

China - Beijing
Tel: 86-10-8569-7000

China - Chengdu
Tel: 86-28-8665-5511

China - Chongqing
Tel: 86-23-8980-9588

China - Dongguan
Tel: 86-769-8702-9880

China - Guangzhou
Tel: 86-20-8755-8029

China - Hangzhou
Tel: 86-571-8792-8115

China - Hong Kong SAR
Tel: 852-2943-5100

China - Nanjing
Tel: 86-25-8473-2460

China - Qingdao
Tel: 86-532-8502-7355

China - Shanghai
Tel: 86-21-3326-8000

China - Shenyang
Tel: 86-24-2334-2829

China - Shenzhen
Tel: 86-755-8864-2200

China - Suzhou
Tel: 86-186-6233-1526

China - Wuhan
Tel: 86-27-5980-5300

China - Xian
Tel: 86-29-8833-7252

China - Xiamen
Tel: 86-592-2388138

China - Zhuhai
Tel: 86-756-3210040

ASIA/PACIFIC

India - Bangalore
Tel: 91-80-3090-4444

India - New Delhi
Tel: 91-11-4160-8631

India - Pune
Tel: 91-20-4121-0141

Japan - Osaka
Tel: 81-6-6152-7160

Japan - Tokyo
Tel: 81-3-6880-3770

Korea - Daegu
Tel: 82-53-744-4301

Korea - Seoul
Tel: 82-2-554-7200

Malaysia - Kuala Lumpur
Tel: 60-3-7651-7906

Malaysia - Penang
Tel: 60-4-227-8870

Philippines - Manila
Tel: 63-2-634-9065

Singapore
Tel: 65-6334-8870

Taiwan - Hsin Chu
Tel: 886-3-577-8366

Taiwan - Kaohsiung
Tel: 886-7-213-7830

Taiwan - Taipei
Tel: 886-2-2508-8600

Thailand - Bangkok
Tel: 66-2-694-1351

Vietnam - Ho Chi Minh
Tel: 84-28-5448-2100

EUROPE

Austria - Wels
Tel: 43-7242-2244-39
Fax: 43-7242-2244-393

Denmark - Copenhagen
Tel: 45-4485-5910
Fax: 45-4485-2829

Finland - Espoo
Tel: 358-9-4520-820

France - Paris
Tel: 33-1-69-53-63-20
Fax: 33-1-69-30-90-79

Germany - Garching
Tel: 49-8931-9700

Germany - Haan
Tel: 49-2129-3766400

Germany - Heilbronn
Tel: 49-7131-72400

Germany - Karlsruhe
Tel: 49-721-625370

Germany - Munich
Tel: 49-89-627-144-0
Fax: 49-89-627-144-44

Germany - Rosenheim
Tel: 49-8031-354-560

Israel - Ra'anana
Tel: 972-9-744-7705

Italy - Milan
Tel: 39-0331-742611
Fax: 39-0331-466781

Italy - Padova
Tel: 39-049-7625286

Netherlands - Drunen
Tel: 31-416-690399
Fax: 31-416-690340

Norway - Trondheim
Tel: 47-7288-4388

Poland - Warsaw
Tel: 48-22-3325737

Romania - Bucharest
Tel: 40-21-407-87-50

Spain - Madrid
Tel: 34-91-708-08-90
Fax: 34-91-708-08-91

Sweden - Gothenberg
Tel: 46-31-704-60-40

Sweden - Stockholm
Tel: 46-8-5090-4654

UK - Wokingham
Tel: 44-118-921-5800
Fax: 44-118-921-5820