

Portable Design Beyond ON/OFF Fan Control

1 Introduction

Designers of today's electronic products are packing more performance and functionality into smaller and smaller systems. The increased performance often generates additional heat, which degrades the optimal performance of the system. Many products targeted for consumer and business applications need a thermal management strategy that includes actively removing heat from the enclosure with one or more fans.

A simple fan control approach is to simply turn the fan ON when the temperature exceeds a set-point, however, the acoustic penalty for this method is severe. ON/OFF control sufficed for early product generations, but consumers are now demanding that products are both capable and quiet. There are several speed fan control circuits that can be implemented using digital temperature sensors with two temperature programmable interrupt outputs. Digital temperature sensors, such as the EMC1001, EMC1002, and EMC1033, provide high accuracy and ease-of-use at a low cost and can support three speed fan controls with just a few additional components.

LCD, plasma and projection TVs, set-top boxes and projectors are examples of products with high heat-generating components that require active cooling. Consumers expect new products to outperform their predecessors and quiet operation is now a required feature. Products that previously had no fan speed control now must incorporate more sophisticated thermal management at little or no cost increase.

Many product designs include microcontrollers (MCUs) with built-in I2C masters that can interface to a wide variety of peripherals, including I2C and SMBus thermal monitoring ICs.

2 The Value

When ON/OFF fan control is used, the maximum fan noise is generated whenever the fan is ON. And worse, cycling from OFF to full ON fan speed produces an abrupt change that is the most noticeable form of acoustic noise. In many products, a low or medium speed will be adequate to remove heat during normal operation, allowing maximum speeds to be reserved for high ambient or high power dissipation conditions.

The circuits described below use linear voltage control, which involves reducing the fan speed (and thus noise) by operating the fan at a DC voltage lower than the full manufacturer's rating.

In Figure 2.1, "Temperature vs. Fan Speed", it illustrates the relationship between temperature and fan speed as controlled by these circuits. For temperatures below the Limit1 set-point, the fan will either be OFF or at low speed depending on the circuit. Temperatures exceeding Limit1 will cause output Out1# to assert, resulting in a medium fan speed. Temperatures in excess of Limit2 will assert Out2# resulting in high fan speed.

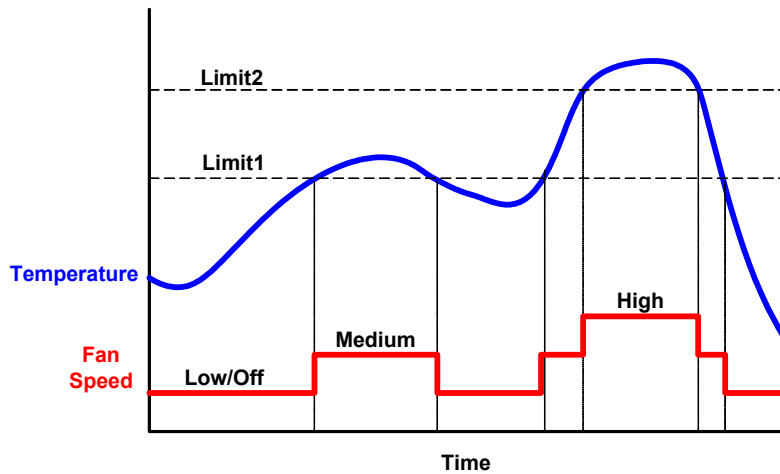

Figure 2.1 Temperature vs. Fan Speed

Note: Digital temperature sensors typically have a programmable hysteresis value that ensures the fan doesn't turn ON and OFF rapidly at a Limit set-point.

SMBus temperature sensor ICs, such as the EMC1001, EMC1002, and EMC1033, include single sensors that measure the IC's ambient temperature, as well as support one or more external sensors in the form of inexpensive diode-connected transistors.

The SMBus communications interface delivers an easy connection to the system microcontroller while the writable registers enable the configuration of the temperature sensor's measurement parameters.

The EMC1001, EMC1002, and EMC1033 have two outputs that will become active low when the temperature exceeds a limit value programmed into a register in the IC. Designers can expect typical sensor accuracies of 1 to 3°C and resolution as fine as 1/8th °C.

The most common drive voltages for DC brushless fans are +5V and +12Vdc. Because operating a fan at full rated speed may cause an objectionable noise, it is important to reduce the fan speed when possible. The voltage required to start a fan is the limiting factor when running DC fans at reduced voltage levels and as a fan ages, the required starting voltage increases due to wear on the bearings.

The actual operating voltage range for a fan varies widely; one manufacturer's +5V rated fan may start and run at 2Vdc, while another fan with the similar dimensions and specifications may require at least 4Vdc to start. When selecting a fan for operation at voltages lower than the manufacturer's ratings, it is essential to characterize the fans and include some margin to account for wear and fan-to-fan variation.

3 Intelligent Control

3.1 Two Transistor 5V Fan Drive

The circuit in Figure 3.1, "Two Transistor 5V Fan Drive" is useful in products that have both +3.3V and +5V supplies. When the temperature is below both of the limit settings, open drain outputs Out1# and Out2# are de-asserted high, allowing R1 and R2 to pull up the gates of P-channel FETs Q1 and Q2, turning them OFF. As the temperature increases to exceed Limit1, OUT1# asserts a low reading, turning on Q1 and applying approximately 3V to the fan through Schottky diode D1. When OUT2# is asserted, Q2 turns ON and 5V is applied to the fan. D2 ensures that 5V will not back-drive onto the 3.3V supply through Q1.

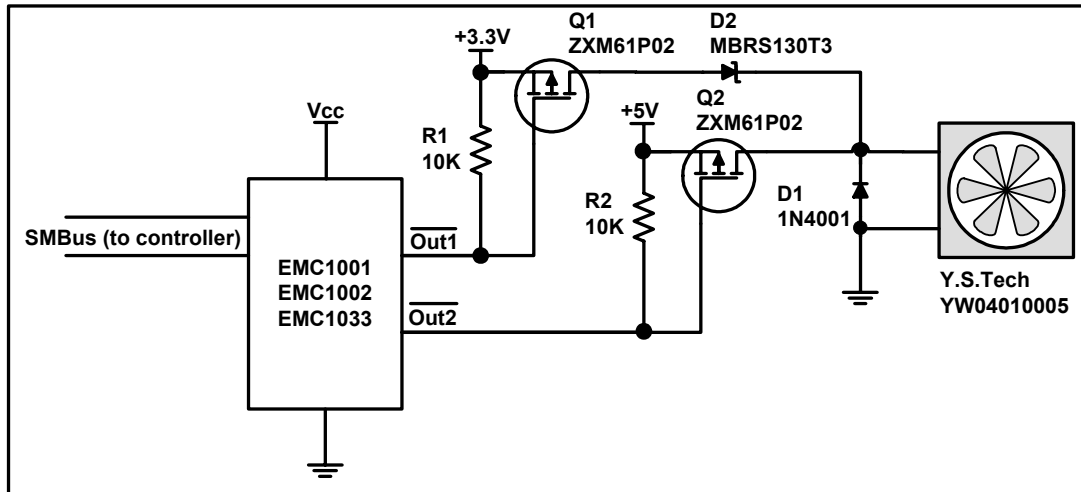

Figure 3.1 Two Transistor 5V Fan Drive

This circuit is very power efficient because there is no wasted transistor base current and the transistors act as switches, connecting the fan directly to the supply rails. Select a P channel FET with $R_{on} < 0.75\Omega @ V_{gs} = 3V$ to keep the voltage drop and power dissipation low. Low power dissipation can permit the use of small SOT-23 devices for fans up to rated currents of 400mA@5V.

3.2 Single Transistor 5V Fan Drive

The circuit in Figure 3.2, "Single Transistor 5V Fan Drive" uses a single PNP transistor to control a fan at three speeds, OFF, medium and high. When the temperature is below both of the limit settings, Out1# and Out2# are de-asserted high. No current flows through Q1's base, so it is OFF and the fan voltage is 0V.

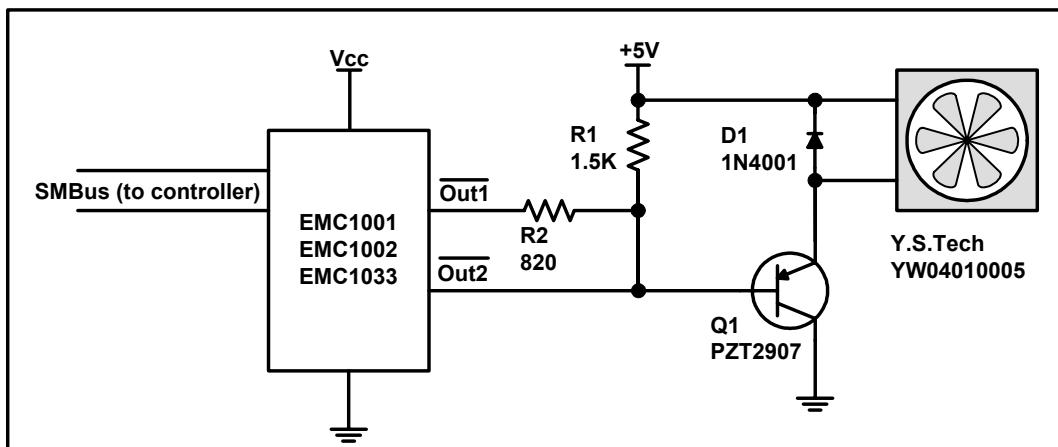

Figure 3.2 Single Transistor 5V Fan Drive

As the temperature exceeds Limit1, Out1# drives low and resistor divider R1/R2 sets the voltage at the base of Q1 to 1.8V. The emitter voltage will be 0.7V higher due to the base-emitter voltage V_{be} , resulting in a fan voltage of 2.5V (50% of full voltage.)

When Out2# asserts low it pulls Q1's base to ground with a current limited by the maximum sink capability of the IC's output device, typically 6-8mA@ $V_{ol} = 0.4V$. With limited base current available, Q1 should have a gain > 100 to ensure minimum voltage drop and strong transistor drive. Voltage drops across the output device and Q1 limit the maximum fan voltage to about 4.1V (82%).

3.3 Single Transistor 12V Fan Drive

The circuit in Figure 3.3, "Single Transistor 12V Fan Drive" is a slight variation on the single transistor circuit, driving a fan to Low/Medium/High speeds. This arrangement allows a 12V fan to be controlled by an IC with 5V tolerant outputs.

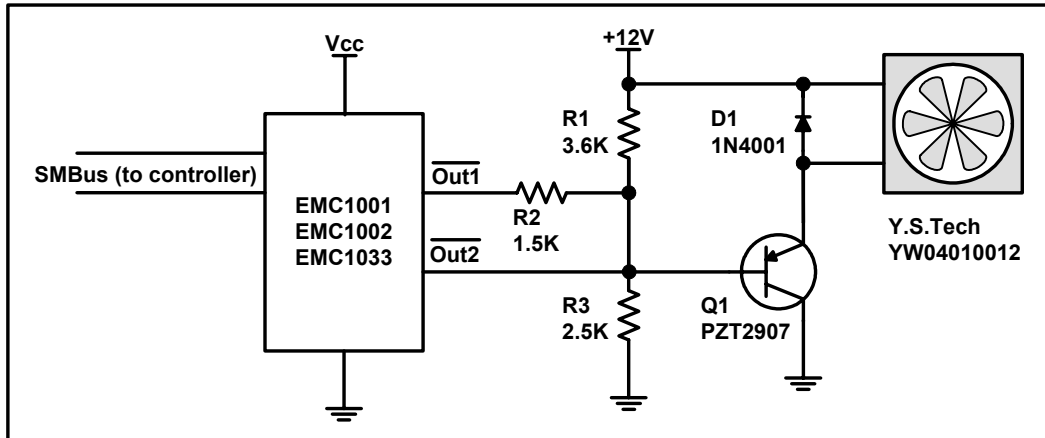

Figure 3.3 Single Transistor 12V Fan Drive

Low speed is set by resistors R1 and R3 when both outputs are de-asserted. The R1/R3 voltage divider sets Q1's base voltage at 5.0V delivering a voltage across the fan of about 6.3V (52%.) Medium speed is produced when Out1# is asserted low, sinking current through R2 to set a base voltage of 2.5V and a fan voltage of 8.8V(73%.) A high-speed voltage of up to 11.1V (92%) is reached when Out2# is asserted low.

4 Summary

Using the EMC1001, EMC1002, or EMC1033 to control fans to three speeds can provide much needed system design flexibility at a very low cost. By using the lower two fan speeds for normal and above average power dissipation scenarios, the fan speed can be set for quiet operation. The highest speed can be reserved for extreme temperatures when the priority for cooling overrides quiet operation.

For more information on the [EMC1001](#), [EMC1002](#) and [EMC1033](#), please visit the SMSC website at: www.smSC.com.



80 Arkay Drive
Hauppauge, NY 11788
(631) 435-6000
FAX (631) 273-3123

Copyright © 2005 SMSC or its subsidiaries. All rights reserved.

Circuit diagrams and other information relating to SMSC products are included as a means of illustrating typical applications. Consequently, complete information sufficient for construction purposes is not necessarily given. Although the information has been checked and is believed to be accurate, no responsibility is assumed for inaccuracies. SMSC reserves the right to make changes to specifications and product descriptions at any time without notice. Contact your local SMSC sales office to obtain the latest specifications before placing your product order. The provision of this information does not convey to the purchaser of the described semiconductor devices any licenses under any patent rights or other intellectual property rights of SMSC or others. All sales are expressly conditional on your agreement to the terms and conditions of the most recently dated version of SMSC's standard Terms of Sale Agreement dated before the date of your order (the "Terms of Sale Agreement"). The product may contain design defects or errors known as anomalies which may cause the product's functions to deviate from published specifications. Anomaly sheets are available upon request. SMSC products are not designed, intended, authorized or warranted for use in any life support or other application where product failure could cause or contribute to personal injury or severe property damage. Any and all such uses without prior written approval of an Officer of SMSC and further testing and/or modification will be fully at the risk of the customer. Copies of this document or other SMSC literature, as well as the Terms of Sale Agreement, may be obtained by visiting SMSC's website at <http://www.smisc.com>. SMSC is a registered trademark of Standard Microsystems Corporation ("SMSC"). Product names and company names are the trademarks of their respective holders.

SMSC DISCLAIMS AND EXCLUDES ANY AND ALL WARRANTIES, INCLUDING WITHOUT LIMITATION ANY AND ALL IMPLIED WARRANTIES OF MERCHANTABILITY, FITNESS FOR A PARTICULAR PURPOSE, TITLE, AND AGAINST INFRINGEMENT AND THE LIKE, AND ANY AND ALL WARRANTIES ARISING FROM ANY COURSE OF DEALING OR USAGE OF TRADE. IN NO EVENT SHALL SMSC BE LIABLE FOR ANY DIRECT, INCIDENTAL, INDIRECT, SPECIAL, PUNITIVE, OR CONSEQUENTIAL DAMAGES; OR FOR LOST DATA, PROFITS, SAVINGS OR REVENUES OF ANY KIND; REGARDLESS OF THE FORM OF ACTION, WHETHER BASED ON CONTRACT; TORT; NEGLIGENCE OF SMSC OR OTHERS; STRICT LIABILITY; BREACH OF WARRANTY; OR OTHERWISE; WHETHER OR NOT ANY REMEDY OF BUYER IS HELD TO HAVE FAILED OF ITS ESSENTIAL PURPOSE, AND WHETHER OR NOT SMSC HAS BEEN ADVISED OF THE POSSIBILITY OF SUCH DAMAGES.