

3 Amp Ultra-Fast Recovery Rectifiers

UFS305J – UFS380J(e3)
UFS305G – UFS380G(e3)



Product Overview

The Microchip UFS305J-UFS380Ge3 in SMC package, ultra-fast recovery rectifiers offer optimized forward voltage characteristics with reverse blocking capabilities from 50–800 volts. They are ideal for surface mount applications that operate at high frequencies.

The SMCG Gull-wing design in the DO-215AB package is ideal for visible solder connections. The SMCJ J-bend design in the DO-214AB package allows for greater PC board mounting density. RoHS compliant versions are available.

Figure 1. DO-215AB Gull-Wing SMCG Package

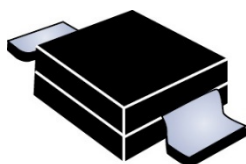

Figure 2. DO-214AB J-Bend SMCJ Package



Features

- Ultra-fast recovery
- 175 °C junction temperature
- 3 amp current rating
- UFS305–UFS320:
 - V_{RWM} 50 to 200 volts
 - t_{rr} 30nS max
- UFS330–UF360:
 - V_{RWM} 300 to 600 volts
 - t_{rr} 50nS max
- UFS370–UFS380:
 - V_{RWM} 700 to 800 volts
 - t_{rr} 60nS max

Table of Contents

| | |
|--|---|
| Product Overview | 1 |
| 1. Maximum Ratings..... | 3 |
| 1.1. Mechanical Packaging..... | 3 |
| 2. Part Nomenclature..... | 4 |
| 2.1. Symbols and Definitions..... | 4 |
| 3. Electrical Characteristics..... | 5 |
| 4. Package Dimensions..... | 6 |
| 5. Pad Layout..... | 7 |
| 6. Revision History..... | 8 |
| Microchip Information..... | 9 |
| Trademarks..... | 9 |
| Legal Notice..... | 9 |
| Microchip Devices Code Protection Feature..... | 9 |

1. Maximum Ratings

Table 1-1. Maximum Ratings

| Parameters/Test Conditions | Symbol | Value | Unit |
|---|-----------------|-------------|------|
| Junction Temperature | T_J | -55 to +175 | °C |
| Storage Temperature | T_{STG} | -55 to +175 | °C |
| Thermal Resistance Junction-to-Lead | $R_{\theta JL}$ | 25 | °C/W |
| Average Rectified Output Current (square wave) | I_O | 3 | A |
| Solder Temperature at 10 seconds | — | 260 | °C |

1.1. Mechanical Packaging

- Case: Void-free transfer molded thermosetting epoxy compound meeting UL94V-0
- Terminals: Tin-lead or RoHS compliant annealed matte-tin plating. Solderable per MIL-STD-750, method 2026
- Marking: See electrical characteristics: device marking, RoHS compliance, date code
- Polarity: Cathode end banded
- Tape and Reel Option: 13 mm tape per standard EIA-481-B. Consult factory for quantities.
- Weight: Approximately 0.24 gram
- See [Package Dimensions](#)

2. Part Nomenclature

Figure 2-1. Part Nomenclature

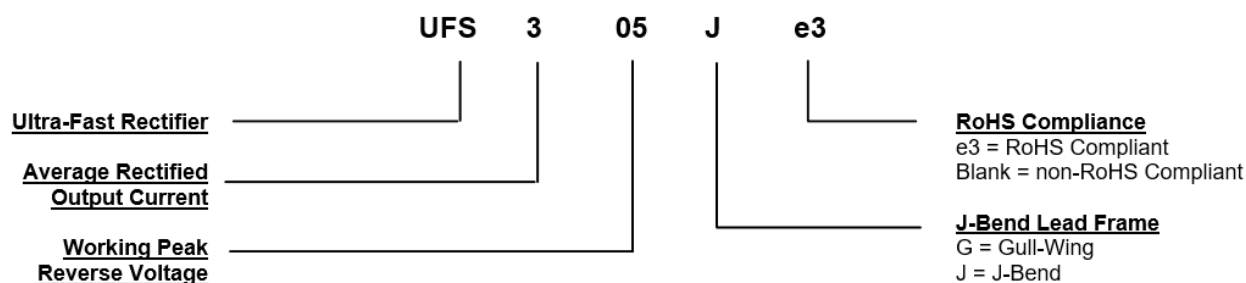

2.1. Symbols and Definitions

Table 2-1. Symbols and Definitions

| Symbol | Definition |
|--------------|---|
| C_T | Total Capacitance: The total small signal capacitance between the diode terminals of a complete device. |
| I_F | Forward Current: The dc current flowing from the external circuit into the anode terminal. |
| I_{FSM} | Surge Peak Forward Current: The forward current including all nonrepetitive transient currents but excluding all repetitive transients (ref JESD282-B). |
| I_O | Average Rectified Output Current: The Output Current averaged over a full cycle with a 50 Hz or 60 Hz sine-wave input and a 180 degree conduction angle. |
| I_R | Reverse Current: The dc current flowing from the external circuit into the cathode terminal at the specified voltage V_R . |
| $I_{R(REC)}$ | Reverse Recovery Current: The transient reverse current associated with a change from forward current to a reverse condition. |
| t_{rr} | Reverse Recovery Time: The time interval between the instant the current passes through zero when changing from the forward direction to the reverse direction and a specified decay point after a peak reverse current occurs. |
| $V_{(BR)}$ | Breakdown Voltage: A voltage in the breakdown region. |
| V_F | Forward Voltage: A positive dc anode-cathode voltage the device will exhibit at a specified forward current. |
| V_R | Reverse Voltage: A positive dc cathode-anode voltage below the breakdown region. |
| V_{RRM} | Repetitive Peak Reverse Voltage: The peak reverse voltage including all repetitive transient voltages but excluding all non-repetitive transient voltages. |
| V_{RWM} | Working Peak Reverse Voltage: The peak voltage excluding all transient voltages (ref JESD282-B). Also sometimes known historically as PIV. |

3. Electrical Characteristics

Table 3-1. Electrical Characteristics at 25 °C Unless Otherwise Stated

| Part Number | Device Marking | Working Peak Reverse Voltage ¹ | Max Reverse Current ² | Max Forward Voltage ² | Max Forward Surge Current ³ | | Capacitance at $V_R = 10\text{ V}$ | Reverse Recovery Time at $I_F = 0.5\text{A}$ at $I_R = 1.0\text{A}$ at $I_{R(\text{REC})} = 0.25\text{A}$ |
|-------------|----------------|---|----------------------------------|----------------------------------|---|--|------------------------------------|--|
| | | V_{RWM} | I_R at V_{RWM} | V_F at $I_F = 3\text{A}$ | I_{FSM} at $T_J = 25\text{ °C}$ | I_{FSM} at $T_J = 175\text{ °C}$ | C_T | t_{rr} |
| | | V | μA | V | A | A | pF | ns |
| UFS305 | U305 | 50 | 10 | 0.95 | 100 | 60 | 38 | 30 |
| UFS310 | U310 | 100 | 10 | 0.95 | 100 | 60 | 38 | 30 |
| UFS315 | U315 | 150 | 10 | 0.95 | 100 | 60 | 38 | 30 |
| UFS320 | U320 | 200 | 10 | 0.95 | 100 | 60 | 38 | 30 |
| UFS330 | U330 | 300 | 10 | 1.1 | — | 100 | 29 | 50 |
| UFS340 | U340 | 400 | 10 | 1.1 | — | 100 | 29 | 50 |
| UFS350 | U350 | 500 | 10 | 1.1 | — | 100 | 29 | 50 |
| UFS360 | U360 | 600 | 10 | 1.1 | — | 100 | 29 | 50 |
| UFS370 | U370 | 700 | 10 | 1.2 | — | 100 | 19 | 60 |
| UFS380 | U380 | 800 | 10 | 1.2 | — | 100 | 19 | 60 |

Notes:

1. Working Peak Reverse Voltage (V_{RWM}), Peak Repetitive Reverse Voltage (V_{RRM}), DC Blocking Voltage (V_R)
2. Short duration test pulse width 300 μs (duty cycle 2%) used to minimize self-heating effect
3. 8.3 ms single half sine wave superimposed on rated load at T_J

4. Package Dimensions

Figure 4-1. SMCG (DO-215AB)

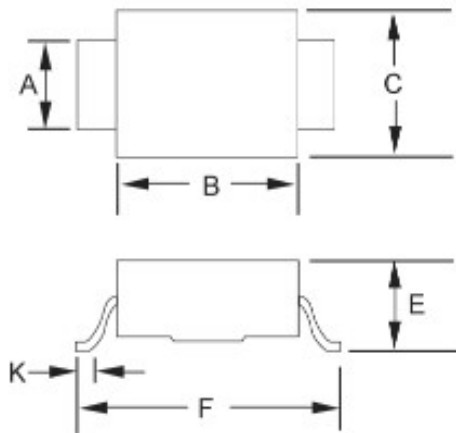

| Ltr | Dimensions | | | |
|-----|------------|-------|-------------|-------|
| | Inch | | Millimeters | |
| | Min. | Max. | Min. | Max. |
| A | 0.115 | 0.121 | 2.92 | 3.07 |
| B | 0.260 | 0.280 | 6.60 | 7.11 |
| C | 0.220 | 0.245 | 5.59 | 6.22 |
| E | 0.077 | 0.110 | 1.95 | 2.80 |
| F | 0.380 | 0.400 | 9.65 | 10.16 |
| K | 0.025 | 0.040 | 0.635 | 1.016 |

Note: Dimension “E” exceeds the JEDEC outline as shown. Typical standoff height: 0.004”–0.008” (0.1 mm–0.2 mm).

Figure 4-2. SMCJ (DO-214AB)

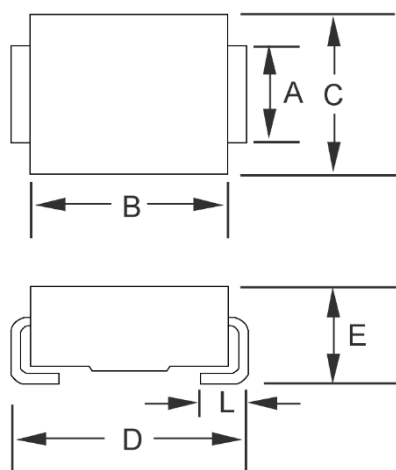

| Ltr | Dimensions | | | |
|-----|------------|-------|-------------|------|
| | Inch | | Millimeters | |
| | Min. | Max. | Min. | Max. |
| A | 0.115 | 0.121 | 2.92 | 3.07 |
| B | 0.260 | 0.280 | 6.60 | 7.11 |
| C | 0.220 | 0.245 | 5.59 | 6.22 |
| D | 0.305 | 0.320 | 7.75 | 8.13 |
| E | 0.077 | 0.110 | 1.95 | 2.80 |
| L | 0.030 | 0.060 | 0.760 | 1.52 |

Note: Dimension “E” exceeds the JEDEC outline in height as shown. Typical standoff height: 0.004”–0.008” (0.1 mm–0.2 mm).

5. Pad Layout

Figure 5-1. Pad Layout

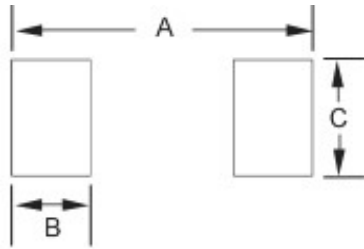

| SMCG (DO-215AB) | | |
|-----------------|-------|-------------|
| Ltr | Inch | Millimeters |
| A | 0.510 | 12.95 |
| B | 0.110 | 2.79 |
| C | 0.150 | 3.81 |

| SMCJ (DO-214AB) | | |
|-----------------|-------|-------------|
| Ltr | Inch | Millimeters |
| A | 0.390 | 9.90 |
| B | 0.110 | 2.79 |
| C | 0.150 | 3.81 |

6. Revision History

The revision history describes the changes that were implemented in the document. The changes are listed by revision, starting with the most current publication.

| Revision | Date | Description |
|----------|---------|---|
| A | 04/2025 | Document was converted to Microchip template and assigned literature number DS00005918. |
| Rev. A | 01/2025 | Microsemi document was created and assigned literature number RF01322. |

Microchip Information

Trademarks

The “Microchip” name and logo, the “M” logo, and other names, logos, and brands are registered and unregistered trademarks of Microchip Technology Incorporated or its affiliates and/or subsidiaries in the United States and/or other countries (“Microchip Trademarks”). Information regarding Microchip Trademarks can be found at <https://www.microchip.com/en-us/about/legal-information/microchip-trademarks>.

ISBN:

Legal Notice

This publication and the information herein may be used only with Microchip products, including to design, test, and integrate Microchip products with your application. Use of this information in any other manner violates these terms. Information regarding device applications is provided only for your convenience and may be superseded by updates. It is your responsibility to ensure that your application meets with your specifications. Contact your local Microchip sales office for additional support or, obtain additional support at www.microchip.com/en-us/support/design-help/client-support-services.

THIS INFORMATION IS PROVIDED BY MICROCHIP “AS IS”. MICROCHIP MAKES NO REPRESENTATIONS OR WARRANTIES OF ANY KIND WHETHER EXPRESS OR IMPLIED, WRITTEN OR ORAL, STATUTORY OR OTHERWISE, RELATED TO THE INFORMATION INCLUDING BUT NOT LIMITED TO ANY IMPLIED WARRANTIES OF NON-INFRINGEMENT, MERCHANTABILITY, AND FITNESS FOR A PARTICULAR PURPOSE, OR WARRANTIES RELATED TO ITS CONDITION, QUALITY, OR PERFORMANCE.

IN NO EVENT WILL MICROCHIP BE LIABLE FOR ANY INDIRECT, SPECIAL, PUNITIVE, INCIDENTAL, OR CONSEQUENTIAL LOSS, DAMAGE, COST, OR EXPENSE OF ANY KIND WHATSOEVER RELATED TO THE INFORMATION OR ITS USE, HOWEVER CAUSED, EVEN IF MICROCHIP HAS BEEN ADVISED OF THE POSSIBILITY OR THE DAMAGES ARE FORESEEABLE. TO THE FULLEST EXTENT ALLOWED BY LAW, MICROCHIP’S TOTAL LIABILITY ON ALL CLAIMS IN ANY WAY RELATED TO THE INFORMATION OR ITS USE WILL NOT EXCEED THE AMOUNT OF FEES, IF ANY, THAT YOU HAVE PAID DIRECTLY TO MICROCHIP FOR THE INFORMATION.

Use of Microchip devices in life support and/or safety applications is entirely at the buyer’s risk, and the buyer agrees to defend, indemnify and hold harmless Microchip from any and all damages, claims, suits, or expenses resulting from such use. No licenses are conveyed, implicitly or otherwise, under any Microchip intellectual property rights unless otherwise stated.

Microchip Devices Code Protection Feature

Note the following details of the code protection feature on Microchip products:

- Microchip products meet the specifications contained in their particular Microchip Data Sheet.
- Microchip believes that its family of products is secure when used in the intended manner, within operating specifications, and under normal conditions.
- Microchip values and aggressively protects its intellectual property rights. Attempts to breach the code protection features of Microchip products are strictly prohibited and may violate the Digital Millennium Copyright Act.
- Neither Microchip nor any other semiconductor manufacturer can guarantee the security of its code. Code protection does not mean that we are guaranteeing the product is “unbreakable”. Code protection is constantly evolving. Microchip is committed to continuously improving the code protection features of our products.