

---

---

## Hardware Design Checklist

---

---

### 1.0 INTRODUCTION

This document provides a hardware design checklist for the Microchip LAN8830. These checklist items should be followed when utilizing the LAN8830 in a new design. A summary of these items is provided in [Section 9.0, "Hardware Checklist Summary,"](#) on page 15. Detailed information on these subjects can be found in the corresponding section:

- [Section 2.0, "General Considerations"](#)
- [Section 3.0, "Power"](#)
- [Section 4.0, "Ethernet Signals"](#)
- [Section 5.0, "Clock Circuit"](#)
- [Section 6.0, "Digital Interfaces"](#)
- [Section 7.0, "Startup"](#)
- [Section 8.0, "Miscellaneous"](#)

### 2.0 GENERAL CONSIDERATIONS

#### 2.1 Pin Check

Check the pinout of the part against the data sheet. Ensure that all pins match the data sheet and are configured as inputs, outputs, or bidirectional for error checking.

#### 2.2 Ground

- The ground pins, **GND**, should be connected to the solid ground plane on the board.
- It is recommended that all ground connections be tied together to the same ground plane. Separate ground planes are not recommended.

# LAN8830

## 3.0 POWER

- The analog supply (**VDDAH**) is located on pins 1 and 12. This requires a connection to **VDDIO** (created from +2.5V or +3.3V through a ferrite bead) if **VDDAH** and **VDDIO** are the same voltage. Bulk capacitance should be placed on each side of the ferrite bead. Generally, a 100-220Ω (at 100 MHz) ferrite bead is used. Each **VDDAH** pin should include 0.1 μF and 10 μF capacitors to decouple the device. The capacitor size should be SMD\_0603 or smaller.
- The **VDDAL** (pins 4 and 9) is the analog core voltage supply. It should be connected to a +1.1V supply (created from +1.1V through a ferrite bead). Bulk capacitance should be placed on each side of the ferrite bead. Generally, a 100-220Ω (at 100 MHz) ferrite bead is used. Each **VDD** pin should include 0.1 μF and 22 μF capacitors to decouple the device. The capacitor size should be SMD\_0603 or smaller.
- The **VDDIO** (pins 17, 24, 28, 35, and 41) is the variable supply voltage for the I/O pads. It should be connected to the +3.3V, 2.5V, or 1.8V supply. A bulk capacitor is needed close to the source to prevent any droop in the supply when the part starts. Decoupling capacitors must be placed as close as possible to the part to reduce high frequency noise being injected through EMI interference.
- The **VDD** (pins 23, 27, 31, and 40) is the digital core voltage supply. It should be connected to the +1.1V supply. A bulk capacitor is needed close to the source to prevent any droop in the supply when the part starts. Decoupling capacitors must be placed as close as possible to the part to reduce high frequency noise being injected through EMI interference.
- **VDDAL\_PLL** (pin 47) supplies power to the LAN8830 PLL. Decouple with a 4.7-10 μF capacitor, a 0.1 μF capacitor, and a 0.01 μF capacitor to ground, and join them to the +1.1V power trace or plane through a ferrite bead.
- The power and ground connections without using the LDO are shown in [Figure 3-1](#), and the power and ground connections with the LDO (using an external MOSFET) are shown in [Figure 3-2](#).

**FIGURE 3-1: POWER AND GROUND CONNECTIONS WITHOUT LDO**

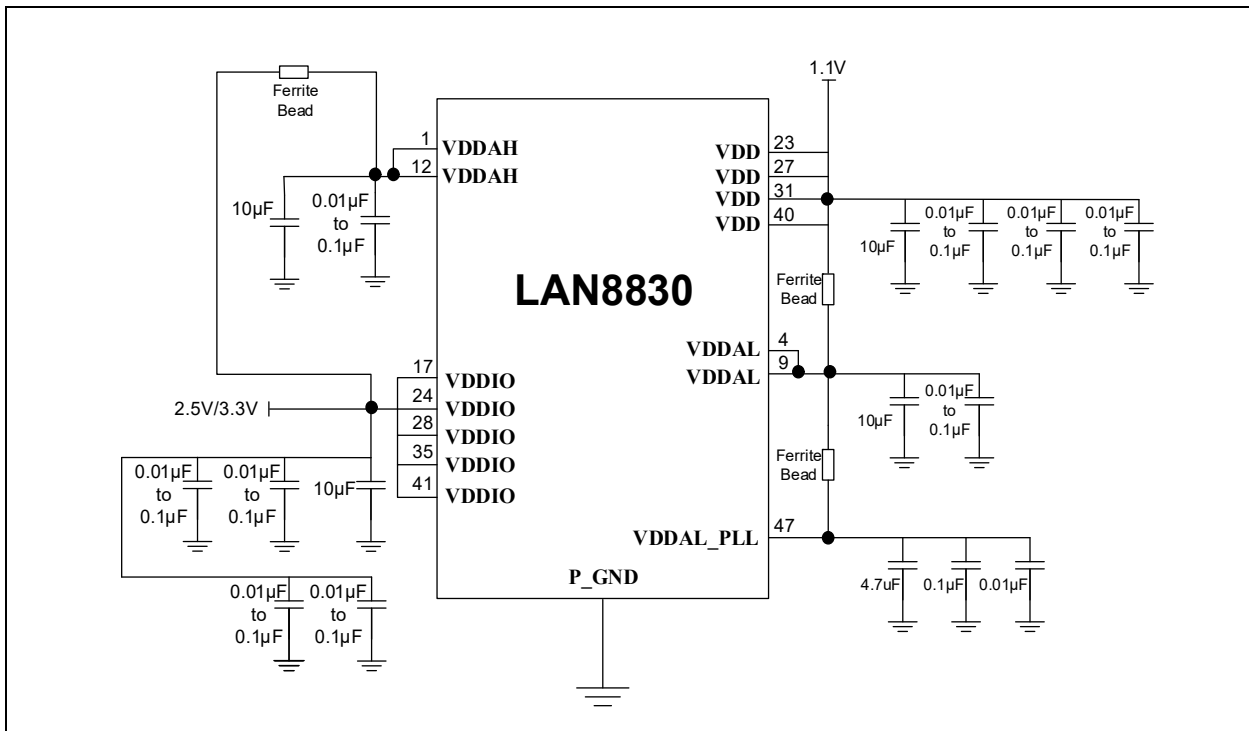

**Caution:** This +1.1V supply is for internal logic only. Do *not* power other circuits or devices with this supply.

**FIGURE 3-2: POWER AND GROUND CONNECTIONS WITH LDO**

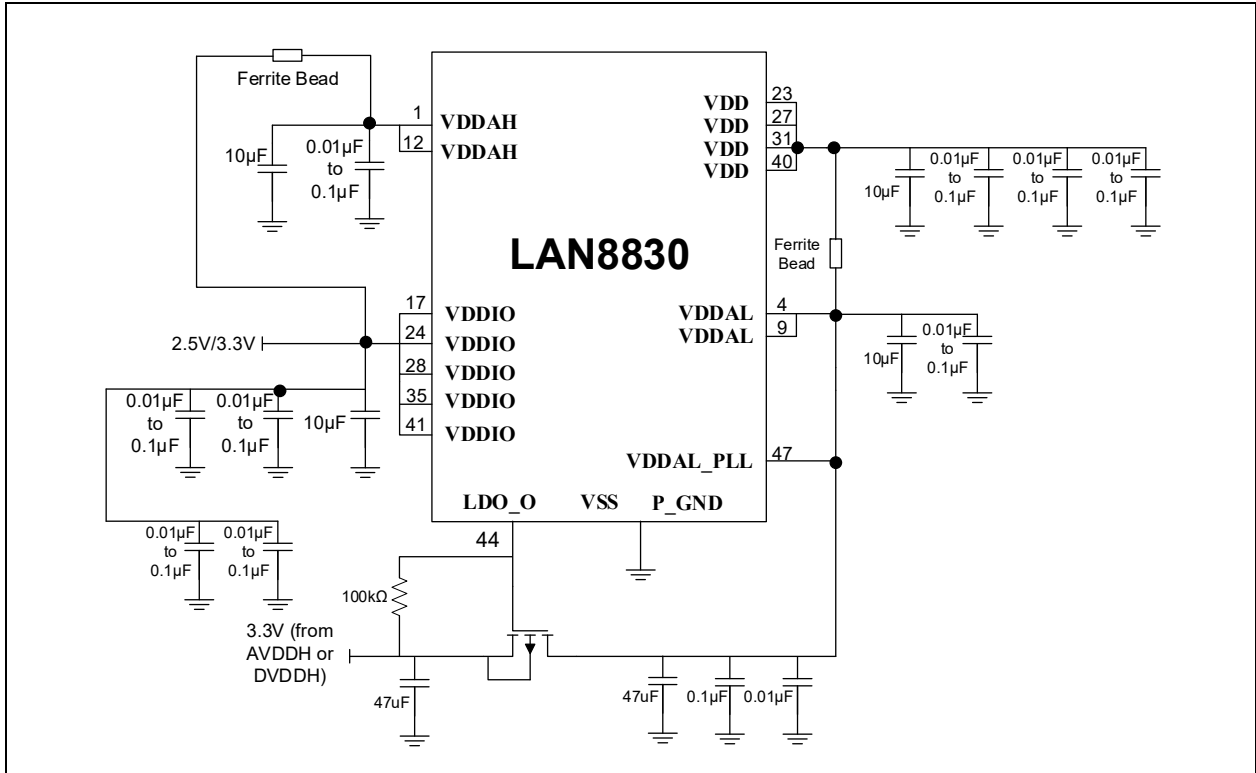

**Caution:** This +1.1V supply is for internal logic only. Do *not* power other circuits or devices with this supply.

# LAN8830

## 4.0 ETHERNET SIGNALS

### 4.1 10/100/1000 Mbps Interface Connection—Separate Center Tap

- **MAGJACK** (pin 14) must be pulled low for either separate center-tap magnetics or separate center-tap magnetic connectors.
- **TXRXP\_A** (pin 2): This pin is the transmit (TX)/receive (RX) positive connection from pair A of the internal PHY. This pin connects to the 10/100/1000 magnetics. No external terminator and bias are needed.
- **TXRXM\_A** (pin 3): This pin is the TX/RX negative connection from pair A of the internal PHY. This pin connects to the 10/100/1000 magnetics. No external terminator and bias are needed.
- **TXRXP\_B** (pin 5): This pin is the TX/RX positive connection from pair B of the internal PHY. This pin connects to the 10/100/1000 magnetics. No external terminator and bias are needed.
- **TXRXM\_B** (pin 6): This pin is the TX/RX negative connection from pair B of the internal PHY. This pin connects to the 10/100/1000 magnetics. No external terminator and bias are needed.
- **TXRXP\_C** (pin 7): This pin is the TX/RX positive connection from pair C of the internal PHY. This pin connects to the 10/100/1000 magnetics. No external terminator and bias are needed.
- **TXRXM\_C** (pin 8): This pin is the TX/RX negative connection from pair C of the internal PHY. This pin connects to the 10/100/1000 magnetics. No external terminator and bias are needed.
- **TXRXP\_D** (pin 10): This pin is the TX/RX positive connection from pair D of the internal PHY. This pin connects to the 10/100/1000 magnetics. No external terminator and bias are needed.
- **TXRXM\_D** (pin 11): This pin is the TX/RX negative connection from pair D of the internal PHY. This pin connects to the 10/100/1000 magnetics. No external terminator and bias are needed.

For 10/100/1000 Mbps channel connections details, refer to [Figure 4-1](#).

**FIGURE 4-1: 10/100/1000 MBPS CHANNEL CONNECTIONS—SEPARATE CENTER TAP**

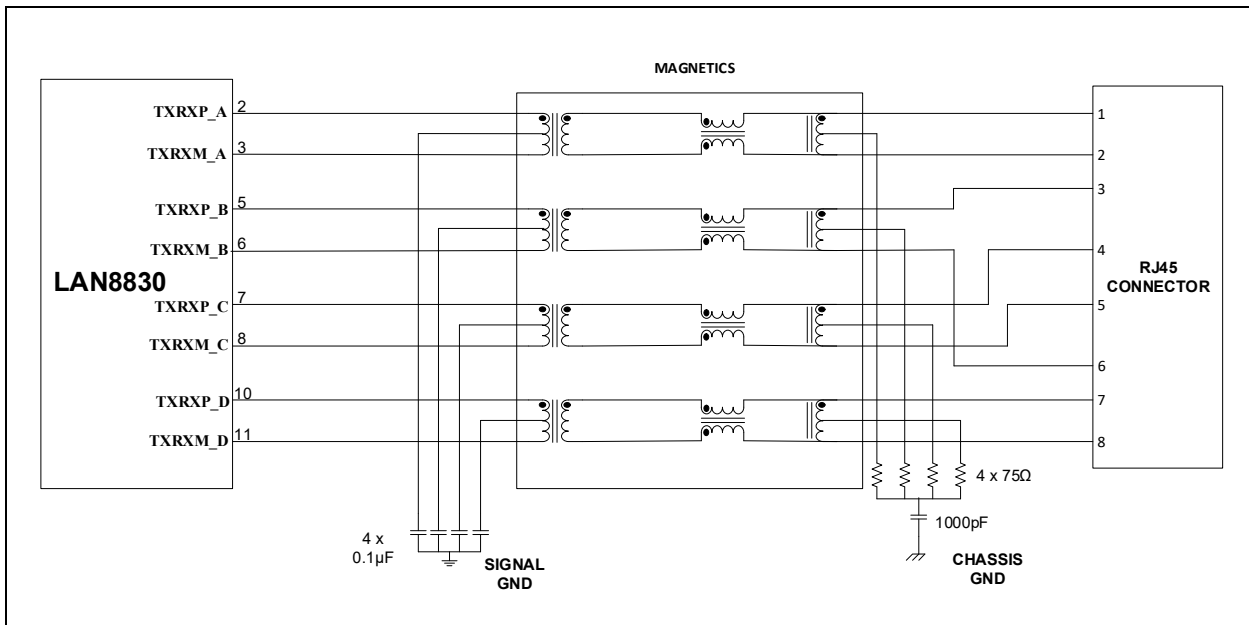

## 4.2 10/100/1000 Magnetics Connection—Separate Center Tap

- The center tap connection on the LAN8830 side for pair A channel only connects a 0.1  $\mu$ F capacitor to GND, and no bias is needed.
- The center tap connection on the LAN8830 side for pair B channel only connects a 0.1  $\mu$ F capacitor to GND, and no bias is needed.
- The center tap connection on the LAN8830 side for pair C channel only connects a 0.1  $\mu$ F capacitor to GND, and no bias is needed.
- The center tap connection on the LAN8830 side for pair D channel only connects a 0.1  $\mu$ F capacitor to GND, and no bias is needed.
- The center taps of the magnetics of all pairs should not be connected together without this 0.1  $\mu$ F capacitor to ground. The reason is that the common-mode voltage can be different between pairs, especially for 10/100 operation (pairs A and B are active while pairs C and D are inactive).
- The center tap connection for each pair (A, B, C, and D) on the cable side (RJ45 side) should be terminated with a 75 $\Omega$  resistor through a common 1000 pF, 2 kV capacitor to chassis ground.
- Only one 1000 pF, 2 kV capacitor to chassis ground is required. It is shared by pair A, pair B, pair C, and pair D center taps.
- The RJ45 shield should connect to chassis ground. This includes RJ45 connectors with or without integrated magnetics. See [Section 8.3, "Other Considerations"](#) for guidance on how chassis ground should be created from digital or signal ground.

## 4.3 1000 Mbps Interface Connection—Shorted Center Tap

- **MAGJACK** (pin 14) must be pulled high for shorted center-tap magnetics and/or shorted center-tap magnetic connectors.
- **TXXP\_A** (pin 2): This pin is the TX/RX positive connection from pair A of the internal PHY. This pin connects to the 10/100/1000 magnetics. No external terminator and bias are needed.
- **TXXM\_A** (pin 3): This pin is the TX/RX negative connection from pair A of the internal PHY. This pin connects to the 10/100/1000 magnetics. No external terminator and bias are needed.
- **TXXP\_B** (pin 5): This pin is the TX/RX positive connection from pair B of the internal PHY. This pin connects to the 10/100/1000 magnetics. No external terminator and bias are needed.
- **TXXM\_B** (pin 6): This pin is the TX/RX negative connection from pair B of the internal PHY. This pin connects to the 10/100/1000 magnetics. No external terminator and bias are needed.
- **TXXP\_C** (pin 7): This pin is the TX/RX positive connection from pair C of the internal PHY. This pin connects to the 10/100/1000 magnetics. No external terminator and bias are needed.
- **TXXM\_C** (pin 8): This pin is the TX/RX negative connection from pair C of the internal PHY. This pin connects to the 10/100/1000 magnetics. No external terminator and bias are needed.
- **TXXP\_D** (pin 10): This pin is the TX/RX positive connection from pair D of the internal PHY. This pin connects to the 10/100/1000 magnetics. No external terminator and bias are needed.
- **TXXM\_D** (pin 11): This pin is the TX/RX negative connection from pair D of the internal PHY. This pin connects to the 10/100/1000 magnetics. No external terminator and bias are needed.

# LAN8830

For 10/100/1000 Mbps channel connections details, refer to [Figure 4-2](#).

**FIGURE 4-2: 10/100/1000 MBPS CHANNEL CONNECTIONS—SHORTED CENTER TAP**

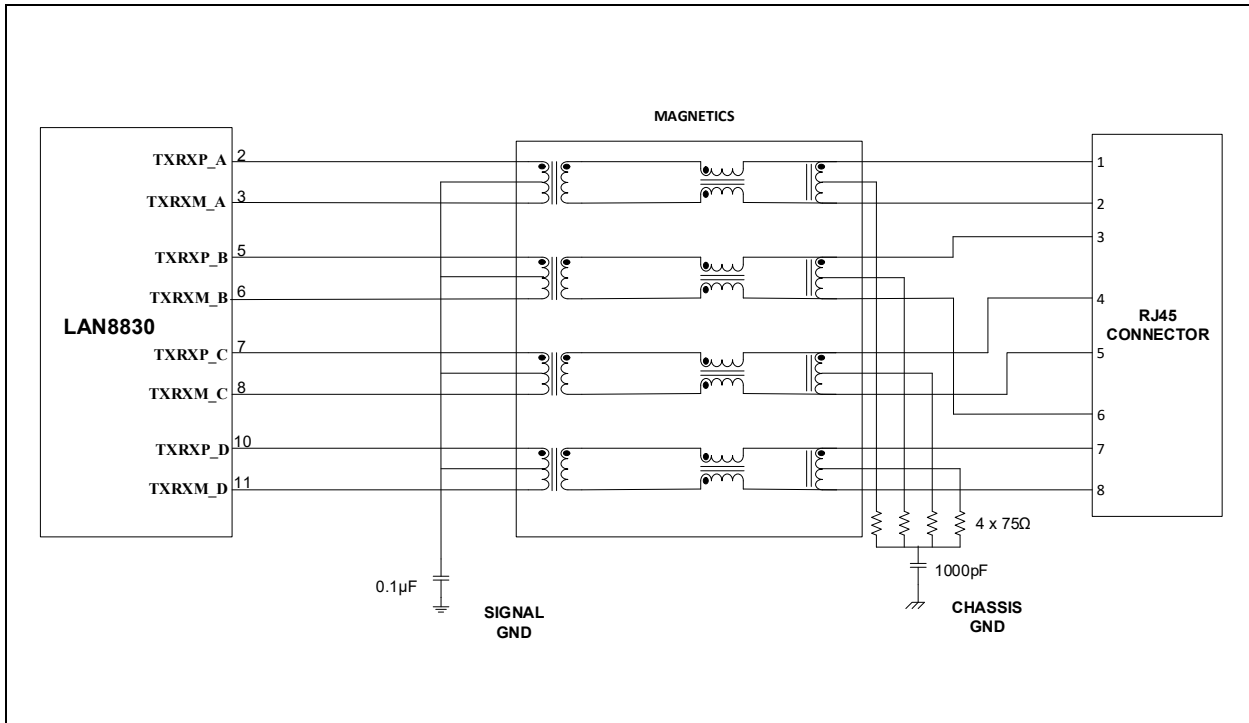

## 4.4 10/100/1000 Magnetics Connection—Shorted Center Tap

- The center tap connection on the LAN8830 side for pairs A, B, C, and D connect to a 0.1  $\mu\text{F}$  capacitor to GND, and no bias is needed.
- The center tap connection for each pair (A, B, C, and D) on the cable side (RJ45 side) should be terminated with a 75 $\Omega$  resistor through a common 1000 pF, 2 kV capacitor to chassis ground.
- Only one 1000 pF, 2 kV capacitor to chassis ground is required. It is shared by pair A, pair B, pair C, and pair D center taps.
- The RJ45 shield should connect to chassis ground. This includes RJ45 connectors with or without integrated magnetics. See [Section 8.3, "Other Considerations"](#) for guidance on how chassis ground should be created from digital or signal ground.

## 4.5 10/100 Mbps Interface Connection—RJ45 Connection

For designs needing only a 10/100 connection, the 1000 Mbps capability must be removed. The following removes the 1000 Mbps advertisement for auto-negotiation:

1. Set Port Register 0x00, Bit [6] = '0' to remove 1000 Mbps speed.
  2. Set Port Register 0x09, Bits [9:8] = '00' to remove auto-negotiation advertisements for 1000 Mbps.
  3. Write a '1' to Register 0x00, Bit [9], a self-clearing bit, to force a restart of auto-negotiation.
- **TXRXP\_A** (pin 2): This pin is the TX/RX positive connection from pair A of the internal PHY. This pin connects to the 10/100 magnetics. No external terminator and bias are needed.
  - **TXRXM\_A** (pin 3): This pin is the TX/RX negative connection from pair A of the internal PHY. This pin connects to the 10/100 magnetics. No external terminator and bias are needed.
  - **TXRXP\_B** (pin 5): This pin is the TX/RX positive connection from pair B of the internal PHY. This pin connects to the 10/100 magnetics. No external terminator and bias are needed.
  - **TXRXM\_B** (pin 6): This pin is the TX/RX negative connection from pair B of the internal PHY. This pin connects to the 10/100 magnetics. No external terminator and bias are needed.
  - **TXRXP\_C** (pin 7): This pin can be left as No Connect (NC).

- **TXRXM\_C** (pin 8): This pin can be left as NC.
- **TXRXP\_D** (pin 10): This pin can be left as NC.
- **TXRXM\_D** (pin 11): This pin can be left as NC.

For 10/100 Mbps channel connections details, refer to [Figure 4-3](#).

**FIGURE 4-3: 10/100 MBPS CHANNEL CONNECTIONS—RJ45 CONNECTION**

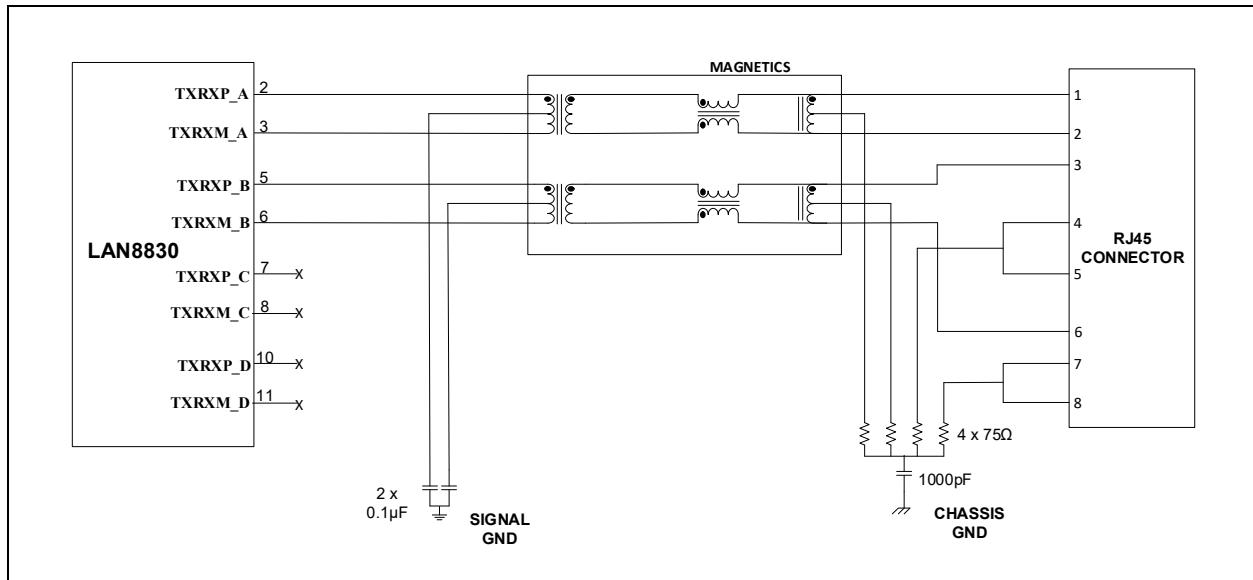

## 4.6 10/100 Magnetics Connection

- The center tap connection on the LAN8830 side for pair A (Transmit Channel) only connects a 0.1  $\mu\text{F}$  capacitor to GND, and no bias is needed.
- The center tap connection on the LAN8830 side for pair B (Receive Channel) only connects a 0.1  $\mu\text{F}$  capacitor to GND, and no bias is needed.
- The center taps of the magnetics of the TX and RX channels should not be connected together. The reason is the common-mode voltage can be different between pairs.
- The center tap connection on the LAN8830 side for the RX channel is connected to the TX channel center tap on the magnetics.
- The center tap connection on the cable side (RJ45 side) for pair A should be terminated with a 75 $\Omega$  resistor through a 1000 pF, 2 kV capacitor to chassis ground.
- The center tap connection on the cable side (RJ45 side) for pair B should be terminated with a 75 $\Omega$  resistor through a 1000 pF, 2 kV capacitor to chassis ground.
- Only one 1000 pF, 2 kV capacitor to chassis ground is required. It is shared by both pair A and pair B center taps.
- MDI connections:
  - Pin 1 of the RJ45 is TX+ and should trace through the magnetics to **TXRXP\_A** (pin 2) of the LAN8830.
  - Pin 2 of the RJ45 is TX- and should trace through the magnetics to **TXRXM\_A** (pin 3) of the LAN8830.
  - Pin 3 of the RJ45 is RX+ and should trace through the magnetics to **TXRXP\_B** (pin 5) of the LAN8830.
  - Pin 6 of the RJ45 is RX- and should trace through the magnetics to **TXRXM\_B** (pin 6) of the LAN8830.
- MDIX Connections:
  - Pin 3 of the RJ45 is TX+ and should trace through the magnetics to **TXRXP\_B** (pin 6) of the LAN8830.
  - Pin 6 of the RJ45 is TX- and should trace through the magnetics to **TXRXM\_B** (pin 5) of the LAN8830.
  - Pin 1 of the RJ45 is RX+ and should trace through the magnetics to **TXRXP\_A** (pin 2) of the LAN8830.
  - Pin 2 of the RJ45 is RX- and should trace through the magnetics to **TXRXP\_A** (pin 3) of the LAN8830.
- When using the LAN8830 device in the Auto MDIX mode of operation, the use of an Auto MDIX style magnetics module (that is, the one where the two channels are identical) is required.

## 4.7 10/100 Mbps RJ45 Connection

- Pins 4 and 5 of the RJ45 connector interface to one pair of unused wires in CAT-5 type cables. These should be terminated to chassis ground through a 1000 pF, 2 kV capacitor. There are two methods of doing this:
  - Pins 4 and 5 can be connected together with two 49.9Ω resistors. The common connection of these resistors should be connected through a third 49.9Ω resistor to the 1000 pF, 2 kV capacitor.
  - For a lower component count, the resistors can be combined. The two 49.9Ω resistors in parallel perform like a 25Ω resistor. The 25Ω resistor in series with the 49.9Ω resistor causes the entire circuit to function as a 75Ω resistor. So, by shorting pins 4 and 5 together on the RJ45 and terminating them with a 75Ω resistor in series with the 1000 pF, 2 kV capacitor to chassis ground, an equivalent circuit is created.
- Pins 7 and 8 of the RJ45 connector interface to one pair of unused wires in CAT-5 type cables. These should be terminated to chassis ground through a 1000 pF, 2 kV capacitor. There are two methods of doing this:
  - Pins 7 and 8 can be connected together with two 49.9Ω resistors. The common connection of these resistors should be connected through a third 49.9Ω resistor to the 1000 pF, 2 kV capacitor.
  - For a lower component count, the resistors can be combined. The two 49.9Ω resistors in parallel perform like a 25Ω resistor. The 25Ω resistor in series with the 49.9Ω resistor causes the entire circuit to function as a 75Ω resistor. So, by shorting pins 7 and 8 together on the RJ45 and terminating them with a 75Ω resistor in series with the 1000 pF, 2 kV capacitor to chassis ground, an equivalent circuit is created.
- The RJ45 shield should be attached directly to chassis ground. This includes RJ45 connectors with or without integrated magnetics. See [Section 8.3, "Other Considerations"](#) for guidance on how chassis ground should be created from digital or signal ground.

## 5.0 CLOCK CIRCUIT

### 5.1 Crystal and External Oscillator/Clock Connections

A 25.000 MHz ( $\pm 50$  ppm) crystal should be used to provide the clock source. For exact specifications and tolerances, refer to the latest revision of the *LAN8830 Data Sheet*.

- **XI** (pin 46) is the clock circuit input for the LAN8830 device. This pin requires a capacitor to ground. One side of the crystal connects to this pin.
- **XO** (pin 45) is the clock circuit output for the LAN8830 device. This pin requires a capacitor to ground. One side of the crystal connects to this pin.

Since every system design is unique, the capacitor values are system-dependent, based on the  $C_L$  spec of the crystal and the stray capacitance value. The PCB design, crystal, and layout all contribute to the characteristics of this circuit.

Alternatively, a 25.000 MHz, 3.3V clock oscillator may be used to provide the clock source for the LAN8830. When using a single-ended clock source, **XO** should be left floating as a No Connect (NC).

**FIGURE 5-1: CRYSTAL AND OSCILLATOR CONNECTIONS**

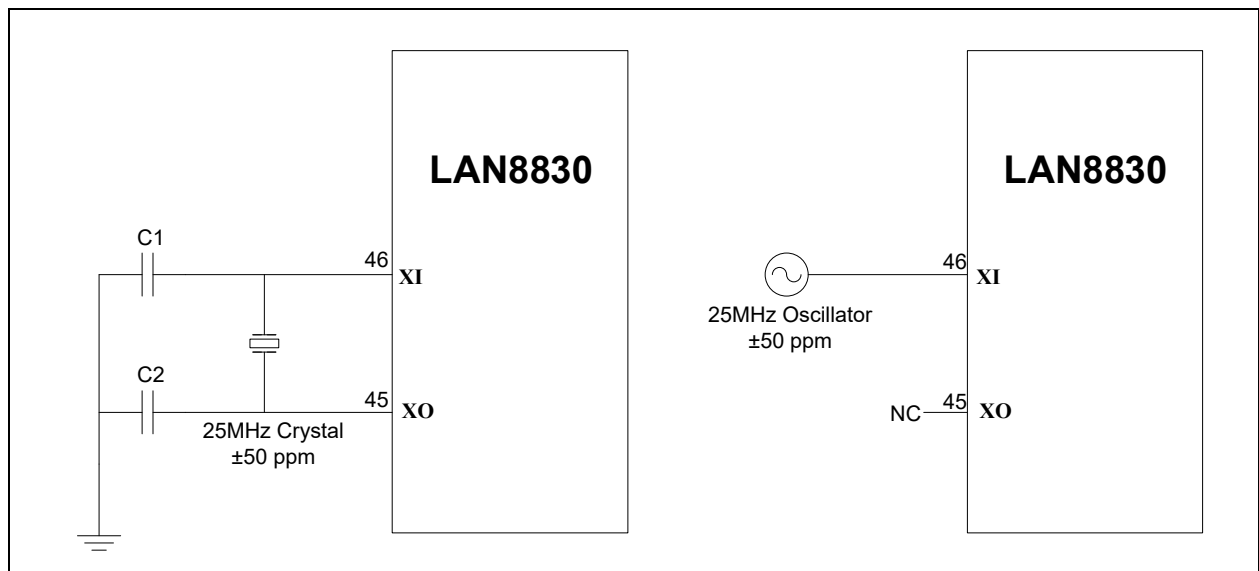

# LAN8830

## 6.0 DIGITAL INTERFACES

### 6.1 RGMII Interface

- When utilizing either an external RGMII MAC interface, [Figure 6-1](#) indicates the proper connections for the 14 signals, including two management pins (MDC and MDIO).
- Provisions should be made for series terminations for all outputs on the RGMII interface. Series resistors enable the designer to closely match the output driver impedance of the LAN8830 and the PCB trace impedance to minimize ringing on the signals. Exact resistor values are application-dependent and must be analyzed in-system. A suggested starting point for the value of these series resistors is 33Ω.

**FIGURE 6-1: RGMII INTERFACE CONNECTIONS**

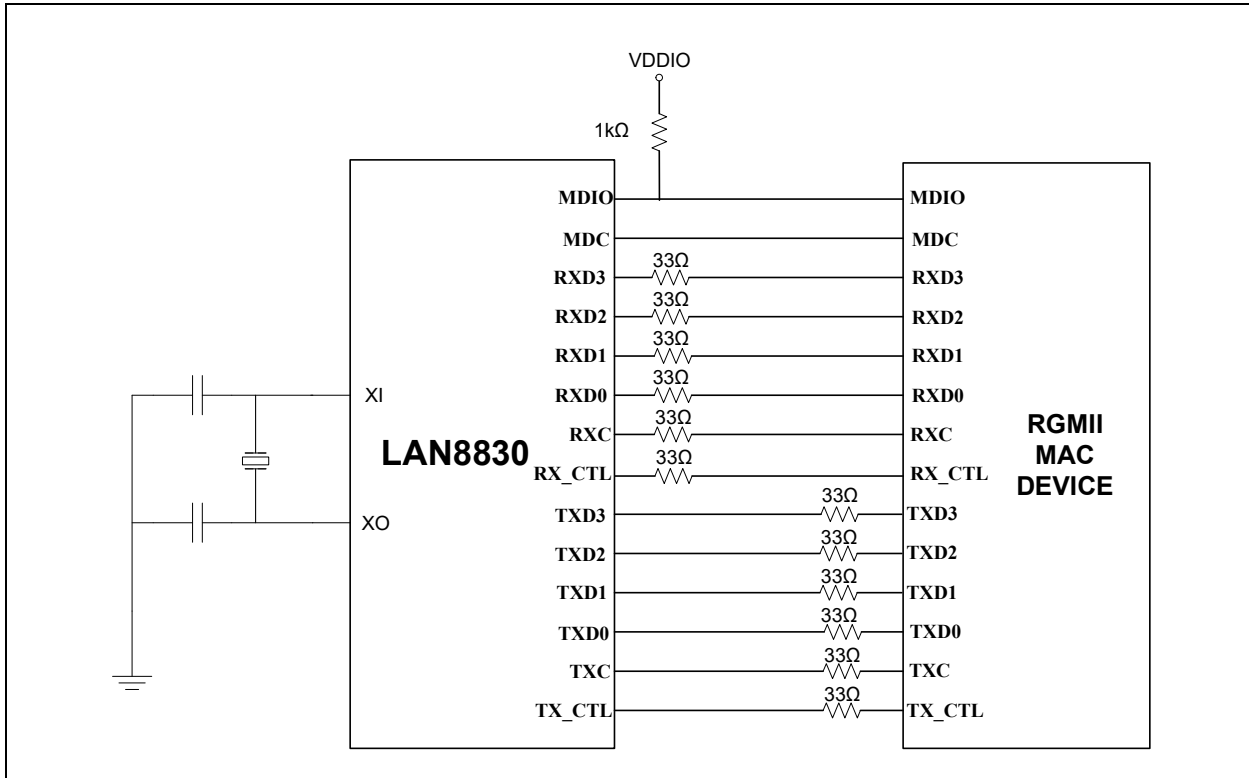

### 6.2 Required External Pull-ups

- When using the LAN8830 MDC/MDIO management pins, a pull-up resistor of 1 kΩ on the **MDIO** signal (pin 38) is required.
- If used, the **INT\_N** pin (pin 39) requires a 4.7 kΩ external pull-up resistor since this output is an open drain. If the **INT\_N** pin is not used, then this pin can float.

## 7.0 STARTUP

### 7.1 Reset Circuit

RESET\_N (pin 43) is an active-low reset input. This signal resets all logic and registers within the LAN8830. A hardware reset (RESET\_N assertion) is required following power-up. Refer to the latest copy of the *LAN8830 Data Sheet* for reset timing requirements. Figure 7-1 shows a recommended reset circuit for powering up the LAN8830 when reset is triggered by the power supply.

**FIGURE 7-1: RESET TRIGGERED BY POWER SUPPLY**

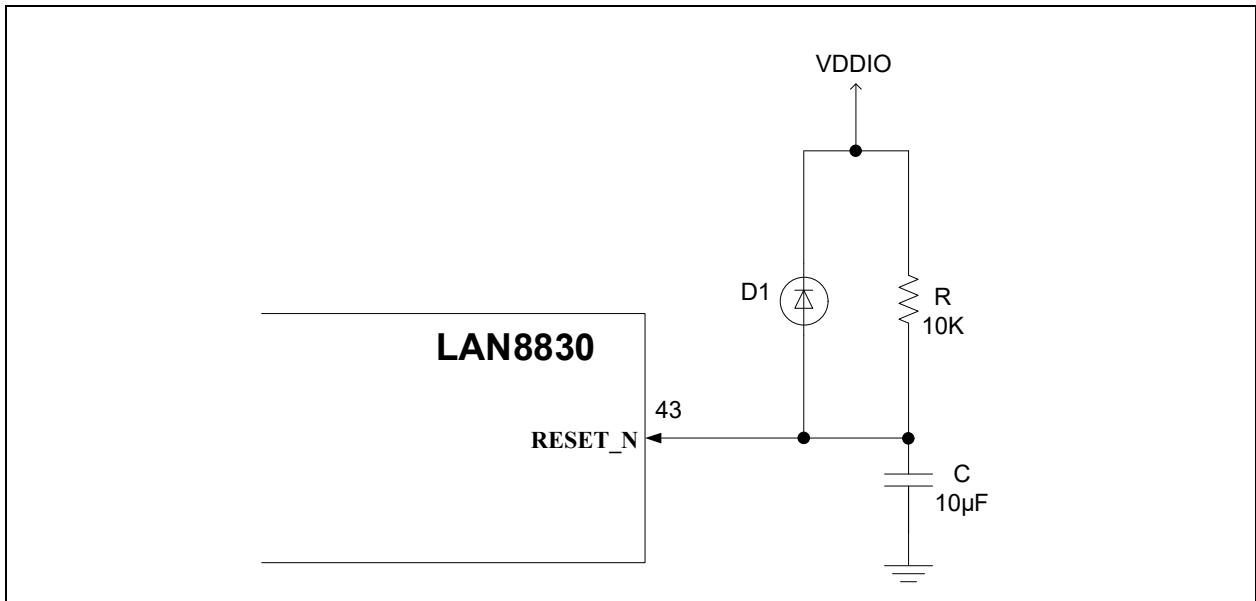
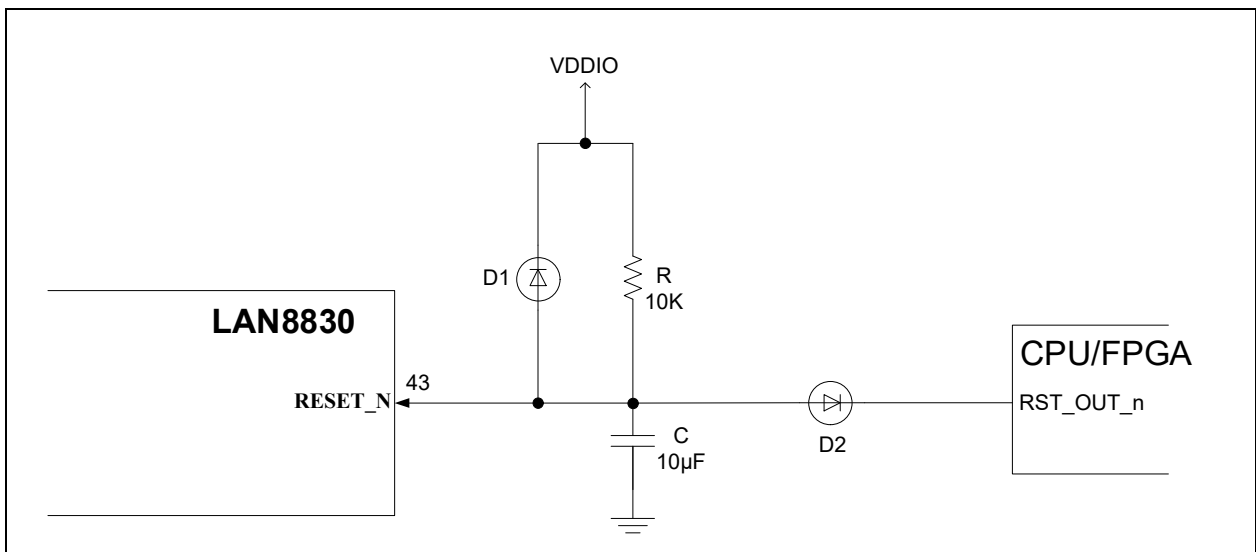

Figure 7-2 details the recommended reset circuit for applications where reset is driven by an external CPU or FPGA. The reset out pin (RST\_OUT\_n) from the CPU/FPGA provides the warm reset after power-up. If the Ethernet device and CPU/FPGA use the same VDDIO voltage, D2 can be removed and both reset pins can be directly connected.

**FIGURE 7-2: RESET CIRCUIT INTERFACE WITH CPU/FPGA RESET OUTPUT**



# LAN8830

---

## 7.2 Configuration Mode Pins (Strapping Options)

The configuration mode pins of the LAN8830 (**MODE[4:0]**) control the default configuration of the LAN8830. Speed, duplex, auto-negotiation, and power-down functionality can be configured through these pins. The values of these strap pins are latched upon power-up and reset. In some systems, the MAC receive input pins may drive high during power-up or reset and consequently cause the PHY strap-in pins on the RGMII signals to be latched high. In this case, it is recommended to add 1 k $\Omega$  pull-downs on these PHY strap-in pins to ensure that the PHY does not strap in to an incorrect MODE configuration or is not configured with an incorrect PHY address. Refer to the *LAN8830 Data Sheet* for complete details for the operation of these pins.

## 7.3 LED Pins

The LAN8830 provides five LED signals. These indicators display speed, link, and activity information about the current state of the PHY. The LED pins drive low to light up the LED indicators, which should have their anode ends tied to 3.3V and their cathode ends tied through a series resistor (typically 220 $\Omega$ -470 $\Omega$ ). Refer to the *LAN8830 Data Sheet* for further details on how to connect each pin for correct operation.

The LED functionality signal pins are shared with the following pin strapping functions:

- **LED1** is shared with **PHYAD0** and **LEDPOL1** on pin 18 for LAN8830.
- **LED2** is shared with **PHYAD1** and **LEDPOL2** on pin 16 for LAN8830.
- **LED3** is shared with **PHYAD2** and **LEDPOL3** on pin 15 for LAN8830.
- **LED4** is shared with **PHYAD3** and **LEDPOL4** on pin 14 for LAN8830.
- **LED5** is shared with **ALLPHYAD** and **LEDPOL5** on pin 13 for LAN8830.

**Note 1:** For 1.8V VDDIO, LED indication support is not recommended due to the low voltage. Without the LED indicator, the **PHYAD3**, **PHYAD2**, **PHYAD1**, and **PHYAD0/PME\_N1** strapping pins are functional with a 10 k $\Omega$  pull-up to 1.8V VDDIO (or be floated) for a value of '1', and with a 1.0 k $\Omega$  pull-down to ground for a value of '0'.

**2:** If using RJ45 jacks with integrated LEDs and 1.8V VDDIO, a level shifting is recommended from 1.8V to 3.3V. In this case, a bipolar transistor or a level shifting device can be used.

## 7.4 GPIO Pins

- The LAN8830 provides seven I/O signals for general use. The GPIO pins are shared with the following signals:
  - **GPIO0** is shared with **LED1** on pin 18 for LAN8830.
  - **GPIO1** is shared with **LED2** on pin 16 for LAN8830.
  - **GPIO2** is shared with **LED3** on pin 15 for LAN8830.
  - **GPIO3** is shared with **LED4** on pin 14 for LAN8830.
  - **GPIO4** is shared with **LED5** on pin 13 for LAN8830.
  - **GPIO5** is shared with **INT\_N** on pin 39 for LAN8830.
  - **GPIO6** is shared with **CLK125\_NDO** on pin 42 for LAN8830.

## 8.0 MISCELLANEOUS

### 8.1 ISET Resistor

The ISET pin on the LAN8830 must connect to ground through a 6.04 k $\Omega$  resistor with a tolerance of 1.0%. This is used to set up critical bias currents for the embedded 10/100/1000 Ethernet physical device.

### 8.2 CLK125\_NDO

The CLK125\_NDO is sufficient for use in 1588 applications. However, if the CLK125\_NDO is used as a 125 MHz clock input source to a MAC, the CLK125\_NDO can provide the clock if the total capacitance from trace to input of MAC is 10 pF or less. Otherwise, the use of a clock buffer (like the PL102-10) is recommended to increase the drive strength of the CLK125\_NDO clock.

### 8.3 Other Considerations

- Incorporate a large SMD footprint (SMD\_1210) to connect the chassis ground to the digital ground. This allows some flexibility at EMI testing for different grounding options. Leaving the footprint open allows the two grounds to remain separate. Shorting them together with a zero ohm resistor connects them. For best performance, short them together with a cap or a ferrite bead.
- Be sure to incorporate enough bulk capacitors (4.7-22  $\mu$ F) for each power plane.

# LAN8830

---

NOTES:

## 9.0 HARDWARE CHECKLIST SUMMARY

**TABLE 9-1: HARDWARE DESIGN CHECKLIST**

Section	Check	Explanation	√	Notes
Section 2.0, "General Considerations"	Section 2.1, "Pin Check"	Verify that the pins match the data sheet.		
	Section 2.2, "Ground"	Verify that the grounds are tied together.		
Section 3.0, "Power"	Section 3.0, "Power"	<ul style="list-style-type: none"> <li>Ensure that <b>VDDAH</b> is within the range of 2.375V to 2.75V (2.5V nominal) or 3.135V to 3.465V (3.3V nominal) and a 10 <math>\mu</math>F or 22 <math>\mu</math>F capacitor is on each pin bulk capacitor and there are at least two 0.1 <math>\mu</math>F capacitors.</li> <li>Ensure that <b>VDDIO</b> is within the range of 2.375V to 2.75V (2.5V nominal) or 3.135V to 3.465V (3.3V nominal) and a 10 <math>\mu</math>F or 22 <math>\mu</math>F capacitor bulk capacitor and there are at least four 0.1 <math>\mu</math>F capacitors.</li> <li><b>VDDL</b> requires a 10 <math>\mu</math>F or 22 <math>\mu</math>F capacitor bulk capacitor and at least three 0.1 <math>\mu</math>F capacitors.</li> <li><b>VDDAL</b> requires a 10 <math>\mu</math>F or 22 <math>\mu</math>F capacitor bulk capacitor and at least one 0.1 <math>\mu</math>F capacitors.</li> <li>For LDO designs, check the capacitance on both the drain and source of FET have at least 47 <math>\mu</math>F.</li> <li>For LDO designs, make sure that the 100 k<math>\Omega</math> resistor is in place (see <a href="#">Figure 3-2</a>) to prevent in-rush current.</li> </ul>		
Section 4.0, "Ethernet Signals"	Section 4.1, "10/100/1000 Mbps Interface Connection—Separate Center Tap"	Verify each pair's positive and negative connections go to the following: <ul style="list-style-type: none"> <li>Pair A - Pair 1 of the magnetics</li> <li>Pair B - Pair 2 of the magnetics</li> <li>Pair C - Pair 3 of the magnetics</li> <li>Pair D - Pair 4 of the magnetics</li> </ul>		
	Section 4.2, "10/100/1000 Magnetics Connection—Separate Center Tap"	Verify each of pair A, pair B, pair C, and pair D center taps go from a 0.1 $\mu$ F capacitor to digital/signal GND. There cannot be a shorting of the connections to a common point before these capacitors.		
		Each cable side center tap go through a 75 $\Omega$ resistor.		
		All center taps go through a 1000 pF, 2 kV capacitor to chassis GND.		
Section 4.3, "1000 Mbps Interface Connection—Shorted Center Tap"	Verify each pair's positive and negative connections go to the following: <ul style="list-style-type: none"> <li>Pair A - Pair 1 of the magnetics</li> <li>Pair B - Pair 2 of the magnetics</li> <li>Pair C - Pair 3 of the magnetics</li> <li>Pair D - Pair 4 of the magnetics</li> </ul>			

**TABLE 9-1: HARDWARE DESIGN CHECKLIST (CONTINUED)**

Section	Check	Explanation	√	Notes
	Section 4.4, "10/100/1000 Magnetics Connection—Shorted Center Tap"	Verify pair A, pair B, pair C, and pair D are tied together and then go to a 0.1 $\mu$ F capacitor to digital/signal GND.		
		Each cable side center tap go through a 75 $\Omega$ resistor.		
		All center taps go through a 1000 pF, 2 kV capacitor to chassis GND.		
	Section 4.5, "10/100 Mbps Interface Connection—RJ45 Connection" (10/100 only)	Verify each pair's positive and negative connections go to the following: <ul style="list-style-type: none"> <li>• Pair A - Pair 1 of the magnetics</li> <li>• Pair B - Pair 2 of the magnetics</li> <li>• Pair C - No Connect (NC)</li> <li>• Pair D - No Connect (NC)</li> </ul>		
		Verify each of pair A and pair B center taps go from a 0.1 $\mu$ F capacitor to digital/signal GND.		
	Section 4.6, "10/100 Magnetics Connection"	Verify the magnetics on each cable side center tap goes through a 75 $\Omega$ resistor terminated with RJ45 pins 4/5 and RJ45 pins 7/8 through a 1000 pF, 2 kV capacitor.		
Section 4.7, "10/100 Mbps RJ45 Connection"	Verify that pins 4/5 and 7/8 of the RJ45 connect to CAT-5 cable and are terminated to chassis ground through a 1000 pF, 2 kV capacitor.			
Section 5.0, "Clock Circuit"	Section 5.1, "Crystal and External Oscillator/Clock Connections"	Verify usage of 25 MHz $\pm$ 50 ppm crystal or 25 MHz $\pm$ 50 ppm clock source.		
Section 6.0, "Digital Interfaces"	Section 6.1, "RGMII Interface"	Confirm proper RGMII signals between MAC and PHY interface based on <a href="#">Figure 6-1</a> (RGMII).		
Section 7.0, "Startup"	Section 7.1, "Reset Circuit"	Confirm proper reset circuit design: standalone reset or external CPU/FPGA reset.		
	Section 7.2, "Configuration Mode Pins (Strapping Options)"	Confirm mode settings and PHYAD (PHY Address) settings.		
		In systems where the MAC receive input pins are driven high after reset, it is recommended to add 1 k $\Omega$ pull-downs on the PHY strap pins.		
	Section 7.3, "LED Pins"	If used, confirm proper connections, taking into consideration shared functionality on select LED pins.		
Section 7.4, "GPIO Pins"	If used, confirm proper connections, taking into consideration shared functionality on select GPIO pins.			

**TABLE 9-1: HARDWARE DESIGN CHECKLIST (CONTINUED)**

Section	Check	Explanation	√	Notes
Section 8.0, "Miscellaneous"	Section 8.1, "ISET Resistor"	Confirm proper ISET resistor (6.04 kΩ, 1.0%).		
	Section 8.2, "CLK125_NDO"	If CLK125_NDO is a MAC clock input source, make sure the total capacitance (including LAN8830 pin capacitance, MAC pin capacitance and trace capacitance) is 10 pF or less. Otherwise, a clock buffer (like PL102-10) is recommended.		
	Section 8.3, "Other Considerations"	Incorporate a large SMD footprint (SMD_1210) to connect the chassis ground to the digital ground.  Incorporate sufficient power plane bulk capacitors (4.7-22 μF).		

## APPENDIX A: REVISION HISTORY

TABLE A-1: REVISION HISTORY

Revision Level & Date	Section/Figure/Entry	Correction
DS00004719C (11-04-24)	<a href="#">Section 3.0, "Power"</a>	Updated pin and voltage information.
	<a href="#">Figure 3-1</a>	Updated figure.
	<a href="#">Figure 3-2</a>	Updated figure.
	<a href="#">Section 7.3, "LED Pins"</a>	Changed 4.7 k $\Omega$ to 10 k $\Omega$ in <a href="#">Note 1</a> .
	<a href="#">Section 8.2, "CLK125_NDO"</a>	New section
	<a href="#">Table 9-1</a>	Updated information on new and revised sections.
	All	Made minor updates.
DS00004719B (10-07-22)	<a href="#">Section 3.0, "Power"</a>	Updated <a href="#">Figure 3-2</a> and removed a note underneath it.
DS00004719A (08-19-22)	Initial release	

NOTES:

# LAN8830

---

---

## THE MICROCHIP WEB SITE

Microchip provides online support via our WWW site at [www.microchip.com](http://www.microchip.com). This web site is used as a means to make files and information easily available to customers. Accessible by using your favorite Internet browser, the web site contains the following information:

- **Product Support** – Data sheets and errata, application notes and sample programs, design resources, user's guides and hardware support documents, latest software releases and archived software
- **General Technical Support** – Frequently Asked Questions (FAQ), technical support requests, online discussion groups, Microchip consultant program member listing
- **Business of Microchip** – Product selector and ordering guides, latest Microchip press releases, listing of seminars and events, listings of Microchip sales offices, distributors and factory representatives

## CUSTOMER CHANGE NOTIFICATION SERVICE

Microchip's customer notification service helps keep customers current on Microchip products. Subscribers will receive e-mail notification whenever there are changes, updates, revisions or errata related to a specified product family or development tool of interest.

To register, access the Microchip web site at [www.microchip.com](http://www.microchip.com). Under "Support", click on "Customer Change Notification" and follow the registration instructions.

## CUSTOMER SUPPORT

Users of Microchip products can receive assistance through several channels:

- Distributor or Representative
- Local Sales Office
- Field Application Engineer (FAE)
- Technical Support

Customers should contact their distributor, representative or Field Application Engineer (FAE) for support. Local sales offices are also available to help customers. A listing of sales offices and locations is included in the back of this document.

**Technical support is available through the web site at: <http://microchip.com/support>**

---

---

**Note the following details of the code protection feature on Microchip products:**

- Microchip products meet the specifications contained in their particular Microchip Data Sheet.
- Microchip believes that its family of products is secure when used in the intended manner, within operating specifications, and under normal conditions.
- Microchip values and aggressively protects its intellectual property rights. Attempts to breach the code protection features of Microchip product is strictly prohibited and may violate the Digital Millennium Copyright Act.
- Neither Microchip nor any other semiconductor manufacturer can guarantee the security of its code. Code protection does not mean that we are guaranteeing the product is "unbreakable" Code protection is constantly evolving. Microchip is committed to continuously improving the code protection features of our products.

---

This publication and the information herein may be used only with Microchip products, including to design, test, and integrate Microchip products with your application. Use of this information in any other manner violates these terms. Information regarding device applications is provided only for your convenience and may be superseded by updates. It is your responsibility to ensure that your application meets with your specifications. Contact your local Microchip sales office for additional support or, obtain additional support at <https://www.microchip.com/en-us/support/design-help/client-support-services>.

THIS INFORMATION IS PROVIDED BY MICROCHIP "AS IS". MICROCHIP MAKES NO REPRESENTATIONS OR WARRANTIES OF ANY KIND WHETHER EXPRESS OR IMPLIED, WRITTEN OR ORAL, STATUTORY OR OTHERWISE, RELATED TO THE INFORMATION INCLUDING BUT NOT LIMITED TO ANY IMPLIED WARRANTIES OF NON-INFRINGEMENT, MERCHANTABILITY, AND FITNESS FOR A PARTICULAR PURPOSE, OR WARRANTIES RELATED TO ITS CONDITION, QUALITY, OR PERFORMANCE.

IN NO EVENT WILL MICROCHIP BE LIABLE FOR ANY INDIRECT, SPECIAL, PUNITIVE, INCIDENTAL, OR CONSEQUENTIAL LOSS, DAMAGE, COST, OR EXPENSE OF ANY KIND WHATSOEVER RELATED TO THE INFORMATION OR ITS USE, HOWEVER CAUSED, EVEN IF MICROCHIP HAS BEEN ADVISED OF THE POSSIBILITY OR THE DAMAGES ARE FORESEEABLE. TO THE FULLEST EXTENT ALLOWED BY LAW, MICROCHIP'S TOTAL LIABILITY ON ALL CLAIMS IN ANY WAY RELATED TO THE INFORMATION OR ITS USE WILL NOT EXCEED THE AMOUNT OF FEES, IF ANY, THAT YOU HAVE PAID DIRECTLY TO MICROCHIP FOR THE INFORMATION.

Use of Microchip devices in life support and/or safety applications is entirely at the buyer's risk, and the buyer agrees to defend, indemnify and hold harmless Microchip from any and all damages, claims, suits, or expenses resulting from such use. No licenses are conveyed, implicitly or otherwise, under any Microchip intellectual property rights unless otherwise stated.

**Trademarks**

The Microchip name and logo, the Microchip logo, Adaptec, AVR, AVR logo, AVR Freaks, BesTime, BitCloud, CryptoMemory, CryptoRF, dsPIC, flexPWR, HELDO, IGLOO, JukeBlox, KeeLoq, Klear, LANCheck, LinkMD, maXStylus, maXTouch, MediaLB, megaAVR, Microsemi, Microsemi logo, MOST, MOST logo, MPLAB, OptoLyzer, PIC, picoPower, PICSTART, PIC32 logo, PolarFire, Prochip Designer, QTouch, SAM-BA, SenGenuity, SpyNIC, SST, SST Logo, SuperFlash, Symmetricom, SyncServer, Tachyon, TimeSource, tinyAVR, UNI/O, Vectron, and XMEGA are registered trademarks of Microchip Technology Incorporated in the U.S.A. and other countries.

AgileSwitch, ClockWorks, The Embedded Control Solutions Company, EtherSynch, Flashtec, Hyper Speed Control, HyperLight Load, Libero, motorBench, mTouch, Powermite 3, Precision Edge, ProASIC, ProASIC Plus, ProASIC Plus logo, Quiet-Wire, SmartFusion, SyncWorld, TimeCesium, TimeHub, TimePictra, TimeProvider, and ZL are registered trademarks of Microchip Technology Incorporated in the U.S.A.

Adjacent Key Suppression, AKS, Analog-for-the-Digital Age, Any Capacitor, AnyIn, AnyOut, Augmented Switching, BlueSky, BodyCom, Clockstudio, CodeGuard, CryptoAuthentication, CryptoAutomotive, CryptoCompanion, CryptoController, dsPICDEM, dsPICDEM.net, Dynamic Average Matching, DAM, ECAN, Espresso T1S, EtherGREEN, EyeOpen, GridTime, IdealBridge, IGaT, In-Circuit Serial Programming, ICSP, INICnet, Intelligent Paralleling, IntelliMOS, Inter-Chip Connectivity, JitterBlocker, Knob-on-Display, MarginLink, maxCrypto, maxView, memBrain, Mindi, MIWI, MPASM, MPF, MPLAB Certified logo, MPLIB, MPLINK, mSiC, MultiTRAK, NetDetach, Omniscient Code Generation, PICDEM, PICDEM.net, PICKIT, PICtail, Power MOS IV, Power MOS 7, PowerSmart, PureSilicon, QMatrix, REAL ICE, Ripple Blocker, RTAX, RTG4, SAM-ICE, Serial Quad I/O, simpleMAP, SimpliPHY, SmartBuffer, SmartHLS, SMART-I.S., storClad, SQL, SuperSwitcher, SuperSwitcher II, Switchtec, SynchroPHY, Total Endurance, Trusted Time, TSHARC, Turing, USBCheck, VariSense, VectorBlox, VeriPHY, ViewSpan, WiperLock, XpressConnect, and ZENA are trademarks of Microchip Technology Incorporated in the U.S.A. and other countries.

SQTP is a service mark of Microchip Technology Incorporated in the U.S.A.

The Adaptec logo, Frequency on Demand, Silicon Storage Technology, and Symmcom are registered trademarks of Microchip Technology Inc. in other countries.

GestlC is a registered trademark of Microchip Technology Germany II GmbH & Co. KG, a subsidiary of Microchip Technology Inc., in other countries.

All other trademarks mentioned herein are property of their respective companies.  
© 2022-2024, Microchip Technology Incorporated and its subsidiaries.

All Rights Reserved.

ISBN: 978-1-6683-0507-2

For information regarding Microchip's Quality Management Systems, please visit [www.microchip.com/quality](http://www.microchip.com/quality).



# MICROCHIP

## Worldwide Sales and Service

### AMERICAS

**Corporate Office**  
2355 West Chandler Blvd.  
Chandler, AZ 85224-6199  
Tel: 480-792-7200  
Fax: 480-792-7277  
Technical Support:  
<http://www.microchip.com/support>  
Web Address:  
[www.microchip.com](http://www.microchip.com)

#### Atlanta

Duluth, GA  
Tel: 678-957-9614  
Fax: 678-957-1455

#### Austin, TX

Tel: 512-257-3370

#### Boston

Westborough, MA  
Tel: 774-760-0087  
Fax: 774-760-0088

#### Chicago

Itasca, IL  
Tel: 630-285-0071  
Fax: 630-285-0075

#### Dallas

Addison, TX  
Tel: 972-818-7423  
Fax: 972-818-2924

#### Detroit

Novi, MI  
Tel: 248-848-4000

#### Houston, TX

Tel: 281-894-5983

#### Indianapolis

Noblesville, IN  
Tel: 317-773-8323  
Fax: 317-773-5453  
Tel: 317-536-2380

#### Los Angeles

Mission Viejo, CA  
Tel: 949-462-9523  
Fax: 949-462-9608  
Tel: 951-273-7800

#### Raleigh, NC

Tel: 919-844-7510

#### New York, NY

Tel: 631-435-6000

#### San Jose, CA

Tel: 408-735-9110  
Tel: 408-436-4270

#### Canada - Toronto

Tel: 905-695-1980  
Fax: 905-695-2078

### ASIA/PACIFIC

**Australia - Sydney**  
Tel: 61-2-9868-6733

**China - Beijing**  
Tel: 86-10-8569-7000

**China - Chengdu**  
Tel: 86-28-8665-5511

**China - Chongqing**  
Tel: 86-23-8980-9588

**China - Dongguan**  
Tel: 86-769-8702-9880

**China - Guangzhou**  
Tel: 86-20-8755-8029

**China - Hangzhou**  
Tel: 86-571-8792-8115

**China - Hong Kong SAR**  
Tel: 852-2943-5100

**China - Nanjing**  
Tel: 86-25-8473-2460

**China - Qingdao**  
Tel: 86-532-8502-7355

**China - Shanghai**  
Tel: 86-21-3326-8000

**China - Shenyang**  
Tel: 86-24-2334-2829

**China - Shenzhen**  
Tel: 86-755-8864-2200

**China - Suzhou**  
Tel: 86-186-6233-1526

**China - Wuhan**  
Tel: 86-27-5980-5300

**China - Xian**  
Tel: 86-29-8833-7252

**China - Xiamen**  
Tel: 86-592-2388138

**China - Zhuhai**  
Tel: 86-756-3210040

### ASIA/PACIFIC

**India - Bangalore**  
Tel: 91-80-3090-4444

**India - New Delhi**  
Tel: 91-11-4160-8631

**India - Pune**  
Tel: 91-20-4121-0141

**Japan - Osaka**  
Tel: 81-6-6152-7160

**Japan - Tokyo**  
Tel: 81-3-6880-3770

**Korea - Daegu**  
Tel: 82-53-744-4301

**Korea - Seoul**  
Tel: 82-2-554-7200

**Malaysia - Kuala Lumpur**  
Tel: 60-3-7651-7906

**Malaysia - Penang**  
Tel: 60-4-227-8870

**Philippines - Manila**  
Tel: 63-2-634-9065

**Singapore**  
Tel: 65-6334-8870

**Taiwan - Hsin Chu**  
Tel: 886-3-577-8366

**Taiwan - Kaohsiung**  
Tel: 886-7-213-7830

**Taiwan - Taipei**  
Tel: 886-2-2508-8600

**Thailand - Bangkok**  
Tel: 66-2-694-1351

**Vietnam - Ho Chi Minh**  
Tel: 84-28-5448-2100

### EUROPE

**Austria - Wels**  
Tel: 43-7242-2244-39  
Fax: 43-7242-2244-393

**Denmark - Copenhagen**  
Tel: 45-4485-5910  
Fax: 45-4485-2829

**Finland - Espoo**  
Tel: 358-9-4520-820

**France - Paris**  
Tel: 33-1-69-53-63-20  
Fax: 33-1-69-30-90-79

**Germany - Garching**  
Tel: 49-8931-9700

**Germany - Haan**  
Tel: 49-2129-3766400

**Germany - Heilbronn**  
Tel: 49-7131-72400

**Germany - Karlsruhe**  
Tel: 49-721-625370

**Germany - Munich**  
Tel: 49-89-627-144-0  
Fax: 49-89-627-144-44

**Germany - Rosenheim**  
Tel: 49-8031-354-560

**Israel - Hod Hasharon**  
Tel: 972-9-775-5100

**Italy - Milan**  
Tel: 39-0331-742611  
Fax: 39-0331-466781

**Italy - Padova**  
Tel: 39-049-7625286

**Netherlands - Drunen**  
Tel: 31-416-690399  
Fax: 31-416-690340

**Norway - Trondheim**  
Tel: 47-7288-4388

**Poland - Warsaw**  
Tel: 48-22-3325737

**Romania - Bucharest**  
Tel: 40-21-407-87-50

**Spain - Madrid**  
Tel: 34-91-708-08-90  
Fax: 34-91-708-08-91

**Sweden - Gothenberg**  
Tel: 46-31-704-60-40

**Sweden - Stockholm**  
Tel: 46-8-5090-4654

**UK - Wokingham**  
Tel: 44-118-921-5800  
Fax: 44-118-921-5820