



MICROCHIP

**EVB-USB4624BCUH
Evaluation Board
User's Guide**

Note the following details of the code protection feature on Microchip devices:

- Microchip products meet the specification contained in their particular Microchip Data Sheet.
- Microchip believes that its family of products is one of the most secure families of its kind on the market today, when used in the intended manner and under normal conditions.
- There are dishonest and possibly illegal methods used to breach the code protection feature. All of these methods, to our knowledge, require using the Microchip products in a manner outside the operating specifications contained in Microchip's Data Sheets. Most likely, the person doing so is engaged in theft of intellectual property.
- Microchip is willing to work with the customer who is concerned about the integrity of their code.
- Neither Microchip nor any other semiconductor manufacturer can guarantee the security of their code. Code protection does not mean that we are guaranteeing the product as "unbreakable."

Code protection is constantly evolving. We at Microchip are committed to continuously improving the code protection features of our products. Attempts to break Microchip's code protection feature may be a violation of the Digital Millennium Copyright Act. If such acts allow unauthorized access to your software or other copyrighted work, you may have a right to sue for relief under that Act.

Information contained in this publication regarding device applications and the like is provided only for your convenience and may be superseded by updates. It is your responsibility to ensure that your application meets with your specifications. MICROCHIP MAKES NO REPRESENTATIONS OR WARRANTIES OF ANY KIND WHETHER EXPRESS OR IMPLIED, WRITTEN OR ORAL, STATUTORY OR OTHERWISE, RELATED TO THE INFORMATION, INCLUDING BUT NOT LIMITED TO ITS CONDITION, QUALITY, PERFORMANCE, MERCHANTABILITY OR FITNESS FOR PURPOSE. Microchip disclaims all liability arising from this information and its use. Use of Microchip devices in life support and/or safety applications is entirely at the buyer's risk, and the buyer agrees to defend, indemnify and hold harmless Microchip from any and all damages, claims, suits, or expenses resulting from such use. No licenses are conveyed, implicitly or otherwise, under any Microchip intellectual property rights.

Trademarks

The Microchip name and logo, the Microchip logo, dsPIC, FlashFlex, KEELoQ, KEELoQ logo, MPLAB, PIC, PICmicro, PICSTART, PIC³² logo, rPIC, SST, SST Logo, SuperFlash and UNI/O are registered trademarks of Microchip Technology Incorporated in the U.S.A. and other countries.

FilterLab, Hampshire, HI-TECH C, Linear Active Thermistor, MTP, SEEVAL and The Embedded Control Solutions Company are registered trademarks of Microchip Technology Incorporated in the U.S.A.

Silicon Storage Technology is a registered trademark of Microchip Technology Inc. in other countries.

Analog-for-the-Digital Age, Application Maestro, BodyCom, chipKIT, chipKIT logo, CodeGuard, dsPICDEM, dsPICDEM.net, dsPICworks, dsSPEAK, ECAN, ECONOMONITOR, FanSense, HI-TIDE, In-Circuit Serial Programming, ICSP, Mindi, MiWi, MPASM, MPF, MPLAB Certified logo, MPLIB, MPLINK, mTouch, Omniscent Code Generation, PICC, PICC-18, PICDEM, PICDEM.net, PICKit, PICtail, REAL ICE, rLAB, Select Mode, SQI, Serial Quad I/O, Total Endurance, TSHARC, UniWinDriver, WiperLock, ZENA and Z-Scale are trademarks of Microchip Technology Incorporated in the U.S.A. and other countries.

SQTP is a service mark of Microchip Technology Incorporated in the U.S.A.

GestIC and ULPP are registered trademarks of Microchip Technology Germany II GmbH & Co. KG, a subsidiary of Microchip Technology Inc., in other countries.

A more complete list of registered trademarks and common law trademarks owned by Standard Microsystems Corporation ("SMSC") is available at: www.smisc.com. The absence of a trademark (name, logo, etc.) from the list does not constitute a waiver of any intellectual property rights that SMSC has established in any of its trademarks.

All other trademarks mentioned herein are property of their respective companies.

© 2013, Microchip Technology Incorporated, Printed in the U.S.A., All Rights Reserved.

ISBN: 978-1-62077-534-9

QUALITY MANAGEMENT SYSTEM
CERTIFIED BY DNV
== ISO/TS 16949 ==

Microchip received ISO/TS-16949:2009 certification for its worldwide headquarters, design and wafer fabrication facilities in Chandler and Tempe, Arizona; Gresham, Oregon and design centers in California and India. The Company's quality system processes and procedures are for its PIC[®] MCUs and dsPIC[®] DSCs, KEELoQ[®] code hopping devices, Serial EEPROMs, microperipherals, nonvolatile memory and analog products. In addition, Microchip's quality system for the design and manufacture of development systems is ISO 9001:2000 certified.

Object of Declaration: EVB-USB4624BCUH Evaluation Board

EU Declaration of Conformity

This declaration of conformity is issued by the manufacturer.

The development/evaluation tool is designed to be used for research and development in a laboratory environment. This development/evaluation tool is not a Finished Appliance, nor is it intended for incorporation into Finished Appliances that are made commercially available as single functional units to end users under EU EMC Directive 2004/108/EC and as supported by the European Commission's Guide for the EMC Directive 2004/108/EC (8th February 2010).

This development/evaluation tool complies with EU RoHS2 Directive 2011/65/EU.

For information regarding the exclusive, limited warranties applicable to Microchip products, please see Microchip's standard terms and conditions of sale, which are printed on our sales documentation and available at www.microchip.com.

Signed for and on behalf of Microchip Technology Inc. at Chandler, Arizona, USA

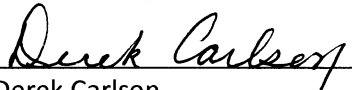

Derek Carlson
VP Development Tools

16-July-2013

Date

NOTES:

Table of Contents

Preface	7
Introduction.....	7
Document Layout	7
Conventions Used in this Guide	9
The Microchip Web Site	10
Development Systems Customer Change Notification Service	10
Customer Support	10
Document Revision History	11
 Chapter 1. Overview	
1.1 Introduction	13
1.2 General Description	14
 Chapter 2. Getting Started	
2.1 Hardware Description	17
2.2 USB4624 Configuration	19
2.3 Clock Source – 24 MHz Crystal	19
2.4 Power Source and Reset – Self-Powered	19
2.5 LEDs and Connectors	20
2.5.1 Powered and Suspend State LEDs	20
2.5.2 RESETn LED	20
2.5.3 Port Power LEDs	20
2.5.4 VBUS Connect and Select LEDs	20
2.5.5 UART LEDs	20
2.5.6 SPI Chip Enable LED	20
2.5.7 Connector Description	21
 Chapter 3. Battery Charging Support	
3.1 Introduction	23
3.2 Charging Port Roles	23
3.2.1 BC1.2 Charging Downstream Port (CDP) Description	24
3.2.2 Standard Downstream Port (SDP) Description	24
3.2.3 Dedicated Charger Emulation Port (DCP) Description	24
 Appendix A. EVB-USB4624BCUH Evaluation Board	
A.1 Introduction	27
 Appendix B. EVB-USB4624BCUH Evaluation Board schematics	
B.1 Introduction	29
 Appendix C. Bill of Materials (BOM)	
C.1 Introduction	33
 Worldwide Sales and Service	39

NOTES:

Preface

NOTICE TO CUSTOMERS

All documentation becomes dated, and this manual is no exception. Microchip tools and documentation are constantly evolving to meet customer needs, so some actual dialogs and/or tool descriptions may differ from those in this document. Please refer to our web site (www.microchip.com) to obtain the latest documentation available.

Documents are identified with a “DS” number. This number is located on the bottom of each page, in front of the page number. The numbering convention for the DS number is “DSXXXXA”, where “XXXX” is the document number and “A” is the revision level of the document.

For the most up-to-date information on development tools, see the MPLAB® IDE online help. Select the Help menu, and then Topics to open a list of available online help files.

INTRODUCTION

This chapter contains general information that will be useful to know before using the EVB-USB4624BCUH Evaluation Board. Items discussed in this chapter include:

- [Document Layout](#)
- [Conventions Used in this Guide](#)
- [The Microchip Web Site](#)
- [Development Systems Customer Change Notification Service](#)
- [Customer Support](#)
- [Document Revision History](#)

DOCUMENT LAYOUT

This document describes how to use the EVB-USB4624BCUH Evaluation Board as a 4-port USB 2.0 hub with USB 2.0/HSIC switchable upstream host and battery charging features.

The manual layout is as follows:

- **Chapter 1. “Overview”** – Shows a brief description of the EVB-USB4624BCUH Evaluation Board.
- **Chapter 2. “Getting Started”** – Includes instructions on how to get started with the EVB-USB4624BCUH Evaluation Board.
- **Chapter 3. “Battery Charging Support”** – Provides information about the EVB-USB4624BCUH Evaluation Board battery charging features.
- **Appendix A. “EVB-USB4624BCUH Evaluation Board”** – This appendix shows the EVB-USB4624BCUH Evaluation Board.
- **Appendix B. “EVB-USB4624BCUH Evaluation Board schematics”** – This appendix shows the EVB-USB4624BCUH Evaluation Board schematics.
- **Appendix C. “Bill of Materials (BOM)”** – This appendix shows the

EVB-USB4624BCUH Evaluation Board Bill of Materials (BOM).

CONVENTIONS USED IN THIS GUIDE

This manual uses the following documentation conventions:

DOCUMENTATION CONVENTIONS

Description	Represents	Examples
Arial font:		
Italic characters	Referenced books	<i>MPLAB[®] IDE User's Guide</i>
	Emphasized text	...is the <i>only</i> compiler...
Initial caps	A window	the Output window
	A dialog	the Settings dialog
	A menu selection	select Enable Programmer
Quotes	A field name in a window or dialog	"Save project before build"
Underlined, italic text with right angle bracket	A menu path	<u><i>File>Save</i></u>
Bold characters	A dialog button	Click OK
	A tab	Click the Power tab
N'Rnnnn	A number in verilog format, where N is the total number of digits, R is the radix and n is a digit.	4'b0010, 2'hF1
Text in angle brackets < >	A key on the keyboard	Press <Enter>, <F1>
Courier New font:		
Plain Courier New	Sample source code	#define START
	Filenames	autoexec.bat
	File paths	c:\mcc18\h
	Keywords	_asm, _endasm, static
	Command-line options	-Opa+, -Opa-
	Bit values	0, 1
	Constants	0xFF, 'A'
Italic Courier New	A variable argument	<i>file.o</i> , where <i>file</i> can be any valid filename
Square brackets []	Optional arguments	mcc18 [options] <i>file</i> [options]
Curly brackets and pipe character: { }	Choice of mutually exclusive arguments; an OR selection	errorlevel {0 1}
Ellipses...	Replaces repeated text	var_name [, var_name...]
	Represents code supplied by user	void main (void) { ... }

THE MICROCHIP WEB SITE

Microchip provides online support via our web site at www.microchip.com. This web site is used as a means to make files and information easily available to customers. Accessible by using your favorite Internet browser, the web site contains the following information:

- **Product Support** – Data sheets and errata, application notes and sample programs, design resources, user's guides and hardware support documents, latest software releases and archived software
- **General Technical Support** – Frequently Asked Questions (FAQs), technical support requests, online discussion groups, Microchip consultant program member listing
- **Business of Microchip** – Product selector and ordering guides, latest Microchip press releases, listing of seminars and events, listings of Microchip sales offices, distributors and factory representatives

DEVELOPMENT SYSTEMS CUSTOMER CHANGE NOTIFICATION SERVICE

Microchip's customer notification service helps keep customers current on Microchip products. Subscribers will receive e-mail notification whenever there are changes, updates, revisions or errata related to a specified product family or development tool of interest.

To register, access the Microchip web site at www.microchip.com, click on Customer Change Notification and follow the registration instructions.

The Development Systems product group categories are:

- **Compilers** – The latest information on Microchip C compilers, assemblers, linkers and other language tools. These include all MPLAB C compilers; all MPLAB assemblers (including MPASM assembler); all MPLAB linkers (including MPLINK object linker); and all MPLAB librarians (including MPLIB object librarian).
- **Emulators** – The latest information on Microchip in-circuit emulators. This includes the MPLAB REAL ICE and MPLAB ICE 2000 in-circuit emulators.
- **In-Circuit Debuggers** – The latest information on the Microchip in-circuit debuggers. This includes MPLAB ICD 3 in-circuit debuggers and PICkit 3 debug express.
- **MPLAB IDE** – The latest information on Microchip MPLAB IDE, the Windows Integrated Development Environment for development systems tools. This list is focused on the MPLAB IDE, MPLAB IDE Project Manager, MPLAB Editor and MPLAB SIM simulator, as well as general editing and debugging features.
- **Programmers** – The latest information on Microchip programmers. These include production programmers such as MPLAB REAL ICE in-circuit emulator, MPLAB ICD 3 in-circuit debugger and MPLAB PM3 device programmers. Also included are nonproduction development programmers such as PICSTART Plus and PIC-kit 2 and 3.

CUSTOMER SUPPORT

Users of Microchip products can receive assistance through several channels:

- Distributor or Representative
- Local Sales Office
- Field Application Engineer (FAE)
- Technical Support

Customers should contact their distributor, representative or field application engineer (FAE) for support. Local sales offices are also available to help customers. A listing of sales offices and locations is included in the back of this document.

Technical support is available through the web site at:

<http://www.microchip.com/support>

DOCUMENT REVISION HISTORY

Revision A (November 2013)

- Initial Release of this Document.

NOTES:

Chapter 1. Overview

1.1 INTRODUCTION

The USB4624 hub controller is a 4-port high-speed, low-power, and configurable Multi-Transaction Translator (MTT) hub controller. It is fully compliant with the USB 2.0 Specification, USB 2.0 Link Power Management (LPM) Addendum and High-Speed Inter-Chip (HSIC) USB Electrical Specification Revision 1.0. The 4-port hub supports 480 Mbps High-Speed (HS), 12 Mbps Full-Speed (FS), and 1.5 Mbps Low-Speed (LS) USB signaling on all of the enabled downstream (non-HSIC) ports. The HSIC ports support only high speed operation. The USB4624 supports both an HSIC upstream host as well as a USB 2.0 upstream host. The USB4624 has four downstream ports and supports both upstream and downstream battery charging.

The EVB-USB4624BCUH is a 4-layer RoHS-compliant evaluation board that utilizes the USB4624 to provide a fully functional 4-port high-speed hub with battery charging capabilities through standard port power controllers. The USB4624 is configured for operation through internal default settings and supports custom configurations through the ProTouch and ProLink tools or an external 8-Mbit SPI Flash device, U17. To allow maximum operational flexibility, all LED and port control signal pins are under firmware control and are available as GPIOs for customer-specific use. The EVB-USB4624BCUH demonstrates driver compatibility with Microsoft® Windows® 7, Windows XP, Mac OS® X 10.4+ and Linux® hub drivers.

The EVB-USB4624BCUH provides the following features:

- USB4624 in a 48-pin QFN RoHS compliant package
- USB 2.0 compliant (HS, FS and LS operation); USB pins are 5V tolerant
- Multi-Transaction Translator (MTT) is enabled
- One upstream port selectable between HSIC or USB 2.0
- Two USB 2.0 downstream ports
- Two HSIC downstream ports
- Self-Powered operation
- Individual port power control and overcurrent sensing
- Battery Charging support (BC1.2 CDP, SDP, and DCP)
- Optional SPI Flash for external downloadable firmware
- Low-Cost, Four-Layer space saving design
- Operates from a single voltage (+12V, regulated) external DC power supply
- Single 24 MHz crystal or external clock input
- Single on board +3.3V, 1 Amp switching regulator
- Single on board +12V, 1 Amp switching regulator
- Two on board +5V switching regulators (one 6 Amp regulator and one 2 Amp regulator)
- +3.3V and port power LED indicators
- Reset, Suspend and VBUS Detect LED indicators
- SPI Chip Enable, UART Transmit and Activity LED indicators
- External GPIO pin and HSIC support headers available
- SMBus and UART interfaces are available

1.2 GENERAL DESCRIPTION

The EVB-USB4624BCUH is an evaluation and demonstration platform featuring the USB4624 Ultra Fast USB 2.0 hub on a 4-layer RoHS compliant Printed Circuit Board (PCB).

The EVB-USB4624BCUH is designed to demonstrate the unique features of this device using a low cost PCB implementation with individual port power control and overcurrent sensing for the downstream USB 2.0 ports. USB 2.0 downstream port 2 and port 3 include a high current port power controller to fully support USB battery charging as a high current walk-up port.

Note: Do not exceed 6A total current consumption from “5V_USB” provided by the U12 +5 VDC switching regulator.

Figure 1-1 shows the top and bottom level silk screen and copper layers. Figure 1-2 shows the functional block diagram.

FIGURE 1-1: TOP AND BOTTOM LEVEL SILK SCREEN AND COPPER LAYERS

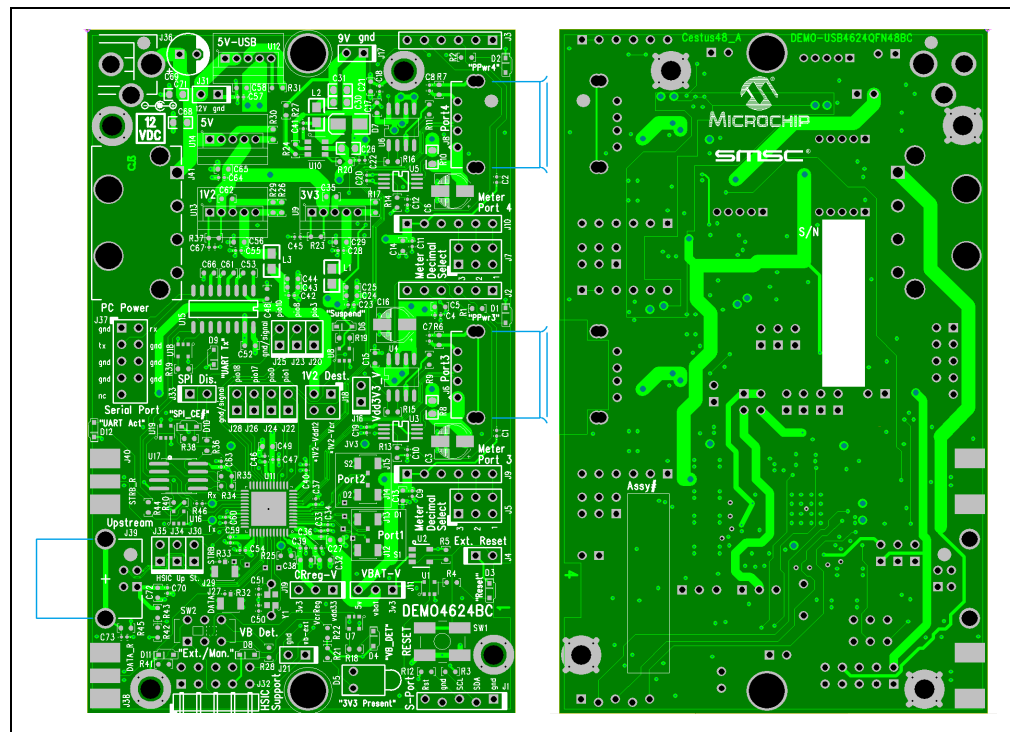

FIGURE 1-2: EVB-USB4624BCUH FUNCTIONAL BLOCK DIAGRAM

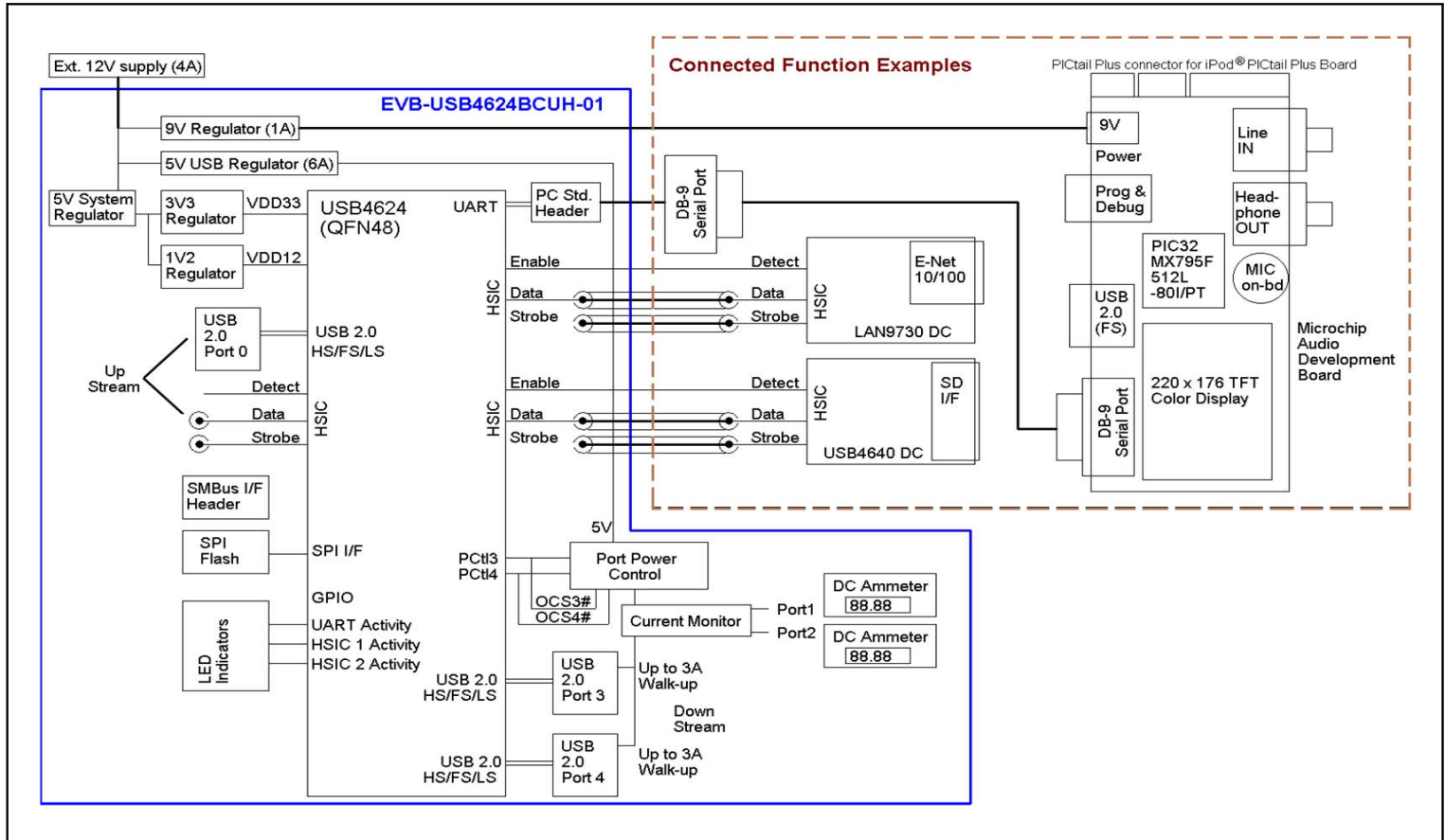
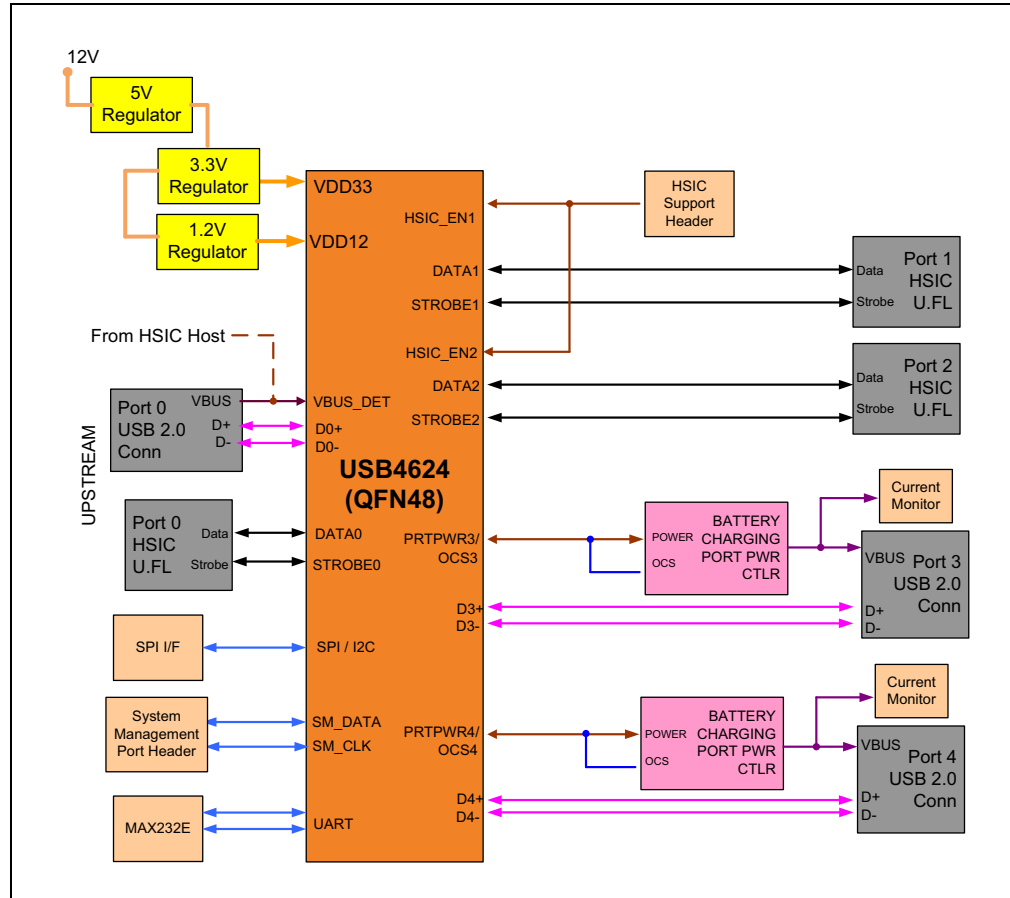

Figure 1-3 shows the typical application of this evaluation board.

FIGURE 1-3: TYPICAL EVB-USB4624BCUH APPLICATION



Chapter 2. Getting Started

2.1 HARDWARE DESCRIPTION

The EVB-USB4624BCUH can be connected to either a USB 2.0 or HSIC upstream host. When using a USB 2.0 host, a standard USB cable must be inserted into the J39 USB style B connector. The VBUS_DET Select switch (SW2) should be set to “External” position and the green “External” LED (D11) is turned on. Once the USB host is attached, VBUS will be detected and the blue VBUS_DET LED (D4) lights up.

When using an HSIC host, the provided U.FL coaxial cables should be inserted onto the J27 (DATA) and J29 (STROBE) connectors. The VBUS_DET Select switch can then be set to either “External” or “Manual” position. When in “Manual” position, VBUS_DET is pulled high to +3.3 VDC and the yellow “Manual” LED (D8) lights up. When the SW2 is in “External” position, the green “External” LED (D11) lights up and an external VBUS_DET port control signal from the host must be wired to the “External VBUS_DET” pin of J21. This signal will let the USB4624 know when an HSIC upstream host is ready to attach. Also, when using an HSIC host, the USB 2.0 upstream port signals must be disabled by jumpering the J34 and J35 headers, thereby pulling the USB DP and DM signals high. Additionally, the J30 header must be jumpered to drive +1.2 VDC onto the VDD12P0 pin of the USB4624.

When removing the U.FL coaxial cables from the evaluation board for any reason, an HSIC Extraction tool must be properly used. See [Figure 2-1](#) for the recommended use of this extraction tool per the Hirose data sheet on proper use of U.FL plugs.

FIGURE 2-1: U.FL COAXIAL CABLE EXTRACTION GUIDELINES

Usage Precautions

1. Plugs

(1) Mating/Unmating

- 1) To disconnect the connectors, insert the end portion of U.FL-LP-N-2 under the connector flanges and pull off vertically, in the direction of the connector mating axis.
- 2) To mate the connectors, the mating axes of both connectors must be aligned. The “click” confirms a fully-mated connection. Do not attempt to insert on an extreme angle.

U.FL-LP-N-2 Plug Extraction Tool



Extraction Jig

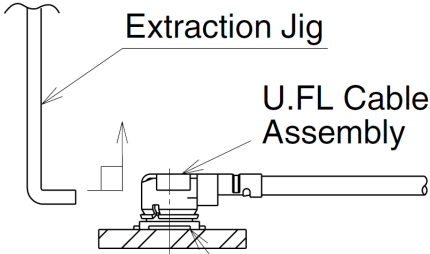

U.FL Cable Assembly

U.FL-R-SMT-1

(2) Pull forces on the cable after the connectors are mated. Do not apply a load to the cable in excess of the values indicated in the diagram below.

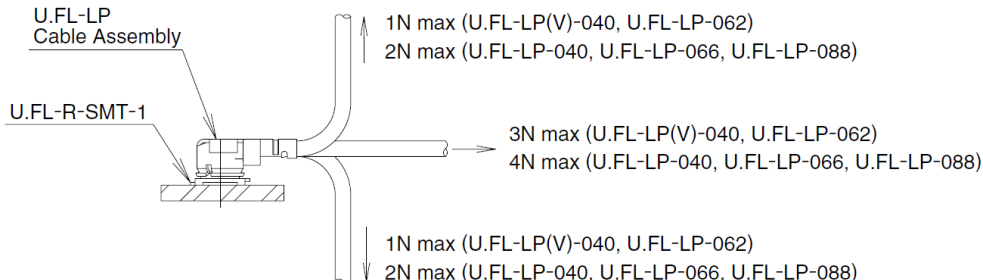

U.FL-LP Cable Assembly

U.FL-R-SMT-1

1N max (U.FL-LP(V)-040, U.FL-LP-062)
2N max (U.FL-LP-040, U.FL-LP-066, U.FL-LP-088)

3N max (U.FL-LP(V)-040, U.FL-LP-062)
4N max (U.FL-LP-040, U.FL-LP-066, U.FL-LP-088)

1N max (U.FL-LP(V)-040, U.FL-LP-062)
2N max (U.FL-LP-040, U.FL-LP-066, U.FL-LP-088)

(3) Precautions

Do NOT forcefully twist or deform wires.

The downstream ports of the EVB-USB4624BCUH are numbered 1 through 4. Downstream ports 1 and 2 are HSIC ports, while downstream port 3 and port 4 are USB 2.0 ports. The USB4624 allows downstream port 3 and/or port 4 to be configured for high current battery USB charging. Power to downstream port 3 and port 4 is controlled through the MAX1562H devices, U4 and U6. Each device provides up to 4A to the corresponding downstream port. These port power controllers have their own power source “5V_USB” which is generated from the U12 +5 VDC switching regulator. This allows a maximum of 3A consumption per port power controller when both USB 2.0 downstream ports are configured for battery charging. The U4 and U6 port power controllers are currently set for a current limit of 2.97 Amps. Power enabling and

overcurrent sensing on downstream port 3 and port 4 is achieved via the PRTPWR3 and PRTPWR4 pins of the USB4624 respectively. The HSIC Enable pins for downstream port 1 and port 2 can be driven by using the HSIC support header J32.

Four female headers (J2, J9, J3, and J10) are also available so that the user can attach a meter and display the current draw at each downstream USB 2.0 port. Please refer to the EVB-USB4624BCUH schematics and Bill of Materials (BOM) for details on these meter devices. Through the MAX232E device, (U15), a UART RS232 interface is provided. The RS232 transmit and receive signals can be accessed via the serial header J37.

The EVB-USB4624BCUH is designed to allow flexible configuration options. It can be configured with default internal register settings, through an SMBus or through a downloadable external firmware to an SPI Flash device. It supports “Quad-Page” configuration OTP flash (four consecutive 200 byte configuration pages). The following sections detail the various configuration methods and features. Note that there are optional footprints available on this evaluation board to support alternate circuitry not discussed in this user manual.

2.2 USB4624 CONFIGURATION

Default: Upon power-up, the USB4624 searches for an external SPI Flash device that contains a valid signature of “2DFU” beginning at address 0xFFFFA. If an SPI device is not present, the firmware checks to see whether SMBus is enabled. If the SMBus is disabled, the USB4624 attempts to load the configuration from an external I²C™ EEPROM. If no external options are detected, the USB4624 will operate using the internal default register settings. It also sets the vendor ID, product ID, language ID, device ID and additional settings from internal ROM code.

SPI Flash Option: If upon power-up, an external SPI Flash device is present, the external ROM is enabled and code execution is initiated from the external SPI device. The SPI Flash device (U17) on the EVB-USB4624BCUH is populated by default. To hold this device in reset and disable the SPI device for any reason, the J33 “SPI Hold” header can be shorted together thereby tying the “HOLD” signal low.

SMBus Option: The SMBus interface is disabled by default via the 10 kOhm pull down resistor on SM_CLK. To enable SMBus, the SM_CLK pin must be pulled high to +3.3 VDC with a strong pull up resistor. This is often embedded within the external SMBus tool (not included) when inserted onto the J1 System Management Port header. All device configuration must be performed via the ProTouch programming tool. For more information on this tool, contact your local sales representative. When SMBus is enabled, the firmware configures the GPIOs to act as an SMBus slave. As an SMBus slave, the firmware waits indefinitely for the SMBus configuration.

2.3 CLOCK SOURCE – 24 MHz CRYSTAL

By default, a 2 mm x 1.6 mm Murata 24 MHz crystal, Y1, is populated on the evaluation board as the clock source for the USB4624.

2.4 POWER SOURCE AND RESET – SELF-POWERED

The EVB-USB4624BCUH only supports self-powered operation, and is powered by one +12 VDC regulated external DC power supply. A +12V input is needed to provide enough current to the downstream ports in battery charging modes. The +12V external DC power supply plugs into the on board 2.5 mm connector J36. Alternatively, an external voltage can be injected onto the external 12V header, J31, which is not populated by default. The +12V feeds two +5 VDC switching regulator modules U12 and U14. The U12 6 Amp regulator generates “5V_USB” to the two port power

controllers for the downstream USB 2.0 ports. This allows each downstream port to consume up to 3 Amps when in battery charging mode. The U14 2 Amp regulator generates “5V” to other miscellaneous circuitry across the evaluation board. The output of the U14 regulator controls the on board +3.3V and +1.2V regulators.

Power to the USB4624 is controlled by the J11, J16, J18, and J19 power headers. These headers are configured by default for an external +3.3V and +1.2V power supply, bypassing the USB4624's internal regulators. For alternative power options, please refer to the USB4624 data sheet.

A voltage supervisor circuit is used to provide a system RESET# to the USB4624. The Microchip device TC1270A (U2) asserts RESET# to the DUT on power up and release it after +3.3V is stable on the USB4624. This on board reset device also monitors any short power off conditions that might occur in the system. If 3V3 falls below +3.08V, the device asserts RESET# to the DUT for a defined period until 3V3 has increased above this voltage trip point. A reset can also be generated to the DUT by pressing the reset switch SW1 or by supplying an external reset via the Reset header J4.

2.5 LEDs AND CONNECTORS

The functions of all the on board LEDs and headers are described on the following sections.

2.5.1 Powered and Suspend State LEDs

The red LED D5 indicates when +3 VDC power is present. The yellow LED D6 indicates when the USB4624 is in Suspend mode.

2.5.2 RESETn LED

The red LED D3 indicates when the RESETn signal is driven low and the USB4624 is held in the Reset state.

2.5.3 Port Power LEDs

The green LEDs D1 and D2 indicate when “5V_USB” port power is available to the associated downstream USB port(s).

2.5.4 VBUS Connect and Select LEDs

The blue LED D4 indicates when an upstream HSIC or USB 2.0 host is present. The green LED D11 indicates when VBUS Select is in “External” mode and the yellow LED D8 indicates when VBUS Select is in the “Manual” mode.

2.5.5 UART LEDs

The green LED D12 indicates when the UART interface is active. The yellow LED D9 indicates when the UART is transmitting data.

2.5.6 SPI Chip Enable LED

The blue LED D10 indicates when the SPI chip is enabled.

2.5.7 Connector Description

The EVB-USB4624BCUH has two USB connectors for downstream port 1 and port 2. The upstream port, as well as downstream port 3, have U.FL connectors for HSIC data and strobe signals. Power is supplied via a 2.1 mm power jack. See [Table 2-1](#) for the list of connectors. For more details on the pinout of these connectors, please refer to the schematics for the EVB-USB4624BCUH.

TABLE 2-1: CONNECTOR DESCRIPTION

CONNECTOR	TYPE	DESCRIPTION
J1	1x5 header	System Management Port
J2, J9	1x6 headers	Socket headers for Current Meter on Port 3
J3, J10	1x6 headers	Socket headers for Current Meter on Port 4
J4	1x2 header	External Reset Control
J6	USB A	USB 2.0 Downstream Port 3
J8	USB A	USB 2.0 Downstream Port 4
J11	1x3 header	VBAT Voltage Selector
J12	U.FL	HSIC STROBE Downstream Port 1
J13	U.FL	HSIC DATA Downstream Port 1
J14	U.FL	HSIC DATA Downstream Port 2
J15	U.FL	HSIC STROBE Downstream Port 2
J16	1x2 header	VDD33 Voltage Select
J18	2x2 header	VDDCR12 Voltage Select
J19	1x3 header	Core Regulator Voltage Select
J20, J22, J23, J24, J25, J26, J28	1x2 headers	GPIO Headers
J21	1x2 header	External VBUS Detect
J27	U.FL	HSIC DATA Upstream Port 0
J29	U.FL	HSIC STROBE Upstream Port 0
J30	1x2 header	1V2 Connect for HSIC Host
J36	Power Jack 2.5 mm	+12 VDC Regulated Power Supply
J31	1x2 header	External +12V Input (not populated)
J32	2x5 header	HSIC Support Header
J33	1x2 header	SPI Disable
J34, J35	1x2 headers	USB 2.0 Upstream Disable
J37	2x5 header	RS232 Serial Header
J39	USB B	Upstream USB 2.0 Port 0

NOTES:

Chapter 3. Battery Charging Support

3.1 INTRODUCTION

The EVB-USB4624BCUH supports several different Battery Charging modes, providing an array of flexible configuration solutions. Both downstream port 1 and port 2 can be separately configured for battery charging via OTP, downloadable external firmware to an on board SPI Flash or through SMBus commands. Each port's configuration is independent of the other ports.

The battery charging mechanism automatically switches ports between states that perform the BC1.2 CDP handshake (which allows full USB communication with a USB host while charging), and states that emulate the dedicated chargers from charging device vendors. This allows support for the BC1.2 CDP mode and emulation of dedicated chargers in DCP mode, without interfering with normal USB operation of any USB 2.0 device attached to the port. Battery charging is supported through the use of standard port power controllers.

Section 3.2 “Charging Port Roles” describes the modes of operation. For more information on battery charging, please refer to the Application Note 34.5 and the USB Battery Charging 1.2 specifications.

3.2 CHARGING PORT ROLES

The EVB-USB4624BCUH's battery charging enabled downstream ports automatically switch between various roles depending on the USB state of the EVB-USB4624BCUH. These roles are:

1. BC1.2 charging downstream port (CDP – 1.5A with data)
2. Standard downstream port (SDP – 0.5A with data)
3. Dedicated charger emulation port (DCP – power brick without data)
4. Custom profiles loaded via SMBus or OTP

When switching between roles, the EVB-USB4624BCUH toggles power to the attached device if appropriate. The power toggle occurs if charger or USB renegotiation is necessary based on the following conditions:

1. If the port is in an SDP role while the hub is disconnected from the host, the port toggles power when switching to a DCP role to allow the downstream device to negotiate with the DCP mechanism.
2. If the port is in a DCP role and the port needs to switch to a CDP or an SDP role, the port toggles power to allow the device to renegotiate with a CDP handshake and/or USB attach.

When battery charging is disabled for a EVB-USB4624BCUH port, the port acts as a normal USB hub port.

When the EVB-USB4624BCUH's upstream port is connected to a USB host and the EVB-USB4624BCUH is not in USB 2.0 suspend and/or USB 2.0 remote wake is enabled, battery charging enabled ports follow the BC1.2 specification for CDPs. In this case, after a USB 2.0 device is attached, the port behaves as an SDP until the device is detached from the hub or the hub is detached from the host.

When a USB port is in a state in which device-host USB communication is not possible, a battery charging enabled port is not required to act as a USB hub port and is therefore free to enter states that emulate dedicated chargers. For the EVB-USB4624BCUH, there are two cases where this applies:

1. The EVB-USB4624BCUH upstream port is not connected to a USB host.
2. The EVB-USB4624BCUH is in USB suspend with remote wake on the USB 2.0 portion of the EVB-USB4624BCUH disabled and no USB 2.0 device connected as a USB device on the downstream port. If USB 2.0 remote wake is disabled, the hub cannot generate resume signaling and does not need to detect a USB 2.0 attach.

In case 2, the EVB-USB4624BCUH's charging ports do not enter dedicated charging states when there is a USB 2.0 device attached as a USB device. There are two reasons for this behavior:

1. Entering dedicated charging states may involve changing the state of an attached device due to power toggling and/or USB linestate changing. Because the host system is unaware of the battery charging mechanism of the EVB-USB4624BCUH, the host could find the device in an unexpected state when exiting suspend.
2. The attached device will not be able to signal resume signaling to the host when the port is in a dedicated charging state. Hubs must propagate resume signaling from downstream devices even when remote wake generation is disabled for the hub.

If the EVB-USB4624BCUH is in USB 2.0 suspend with USB 2.0 remote wake disabled and a USB-attached device is removed from a port, the port switches to the DCP role because possible resume propagation is no longer required.

3.2.1 BC1.2 Charging Downstream Port (CDP) Description

Devices that do not follow the BC1.2 CDP specification behave as they normally would when inserted into a standard USB port. The EVB-USB4624BCUH ports in CDP mode allow normal USB operation/communication between normal devices and USB hosts by switching to the SDP role after downstream device detection and absence of a BC1.2 CDP handshake from the device. When a subsequent device detach is detected, the port switches back to the CDP role.

Devices that follow the BC1.2 CDP specification are also allowed to communicate normally with the USB host when inserted into the EVB-USB4624BCUH ports in CDP mode. Additionally, prior to allowing the normal USB connection between the host and the BC1.2 device, the EVB-USB4624BCUH port performs the BC1.2 CDP handshake to inform the BC1.2-compliant device that it may draw current exceeding the USB specified limits. When the handshake is complete, the port switches to the SDP role to allow USB functionality for the device. When a subsequent device detach is detected, the port switches back to the CDP role.

3.2.2 Standard Downstream Port (SDP) Description

When a port is in the SDP role, it behaves as a normal hub port and allow full USB functionality for an attached downstream device.

3.2.3 Dedicated Charger Emulation Port (DCP) Description

The advantage of the EVB-USB4624BCUH dedicated charger emulation port over the BC1.2-specified DCP is that it supports BC1.2 compliant charging devices and many non-BC1.2 compliant charging devices. The following paragraphs describe the

EVB-USB4624BCUH modes of operation when its downstream ports are in dedicated charging states (when normal USB connection is not required as described in previous sections).

Dynamic Mode:

The EVB-USB4624BCUH can be configured to dynamically react to devices inserted into the downstream ports and emulate the appropriate type of charger for the inserted device. In this configuration, the port begins in Apple® charger emulation mode and switches to China Charging, Blackberry® or BC1.2 device charger emulation when such devices are detected by the port. When a device is detached, the port starts again in Apple charger emulation mode.

Configurable 1A and 2A Apple modes are available depending on the capabilities of each port's port power controller.

An EVB-USB4624BCUH port with a standard port power controller also supports Samsung® Galaxy Tab™ charger emulation in addition to the above modes.

Static Mode:

The EVB-USB4624BCUH can be configured to keep the downstream ports in a fixed charger emulation state. Currently, Apple and Samsung Galaxy Tab or China Charging fixed charger emulation modes are available.

NOTES:

Appendix A. EVB-USB4624BCUH Evaluation Board

A.1 INTRODUCTION

This appendix shows the EVB-USB4624BCUH Evaluation Board.

FIGURE A-1: EVB-USB4624BCUH EVALUATION BOARD

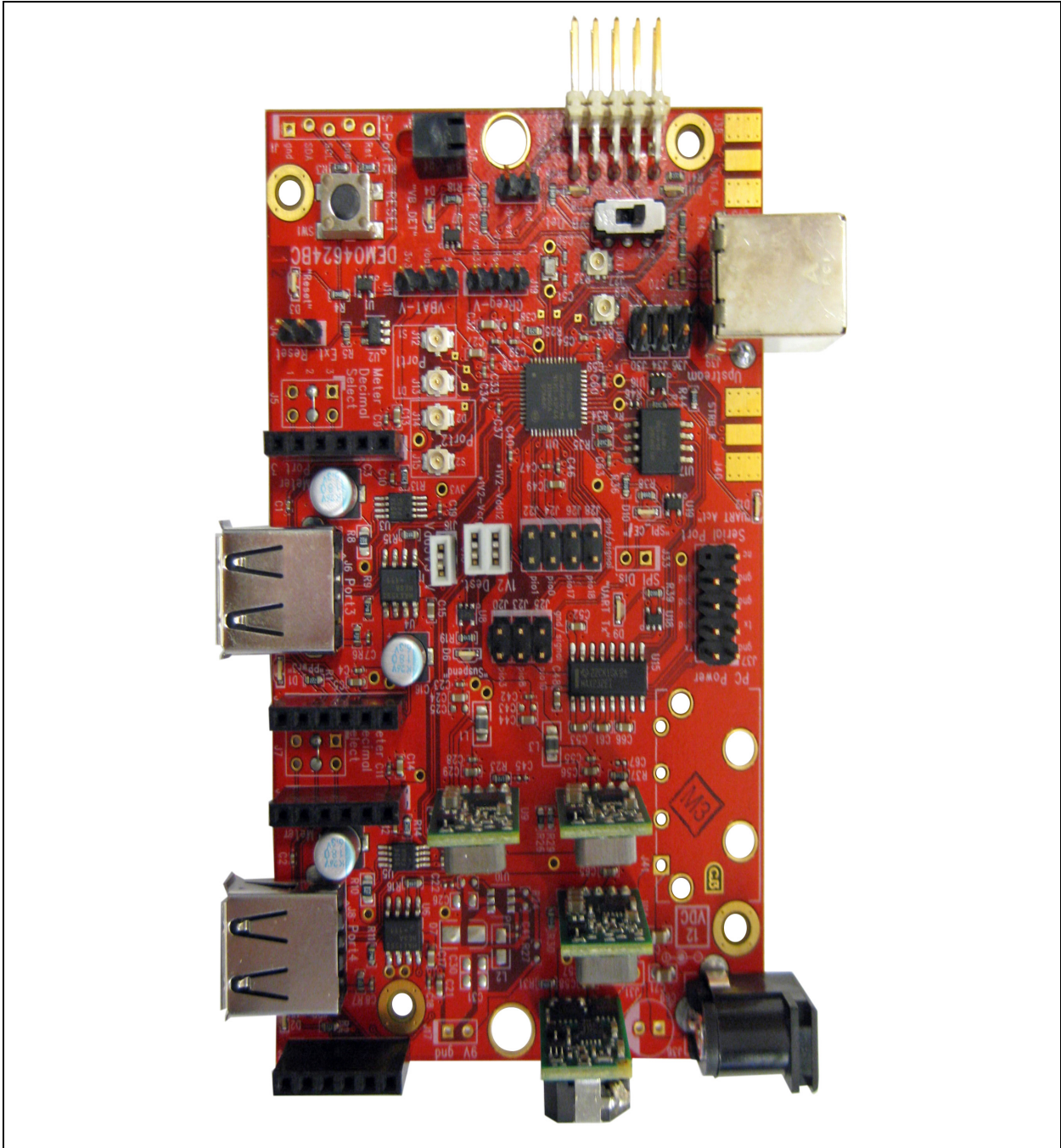

NOTES:



**EVB-USB4624BCUH
EVALUATION BOARD
USER'S GUIDE**

**Appendix B. EVB-USB4624BCUH Evaluation Board
schematics**

B.1 INTRODUCTION

This appendix shows the EVB-USB4624BCUH Evaluation Board schematics.

FIGURE B-1: EVB-USB4624BCUH EVALUATION BOARD SCHEMATIC 1

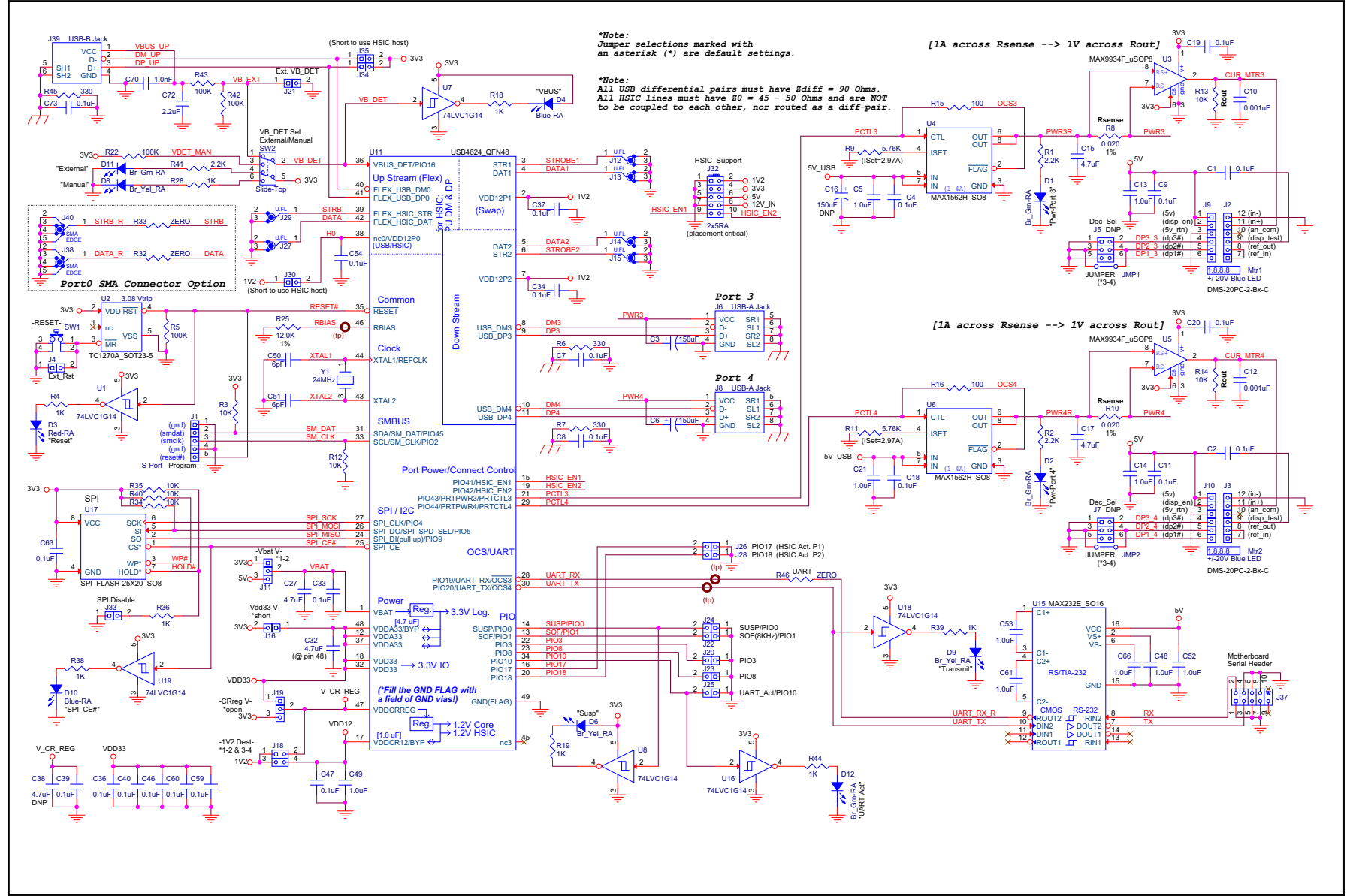
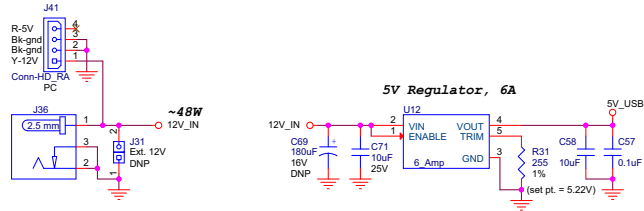
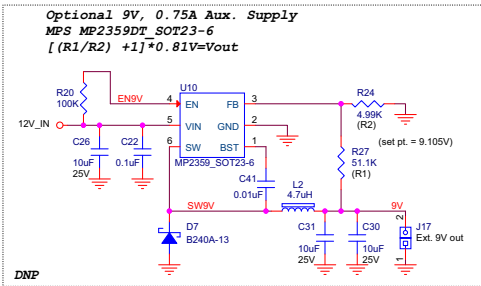
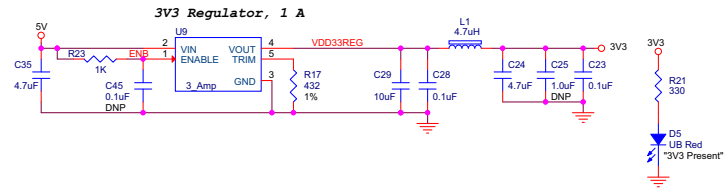
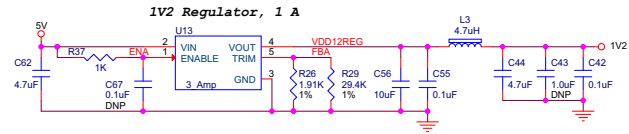
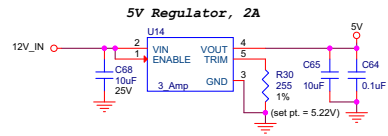

FIGURE B-2: EVB-USB4624BCUH EVALUATION BOARD SCHEMATIC 2



Power Needs:
 12V Input = 4 A
 9V 0.75 A (option)
 5V USB ~6 A
 5V 2 A
 3V3 1 A
 1V2 1 A



NOTES:



Appendix C. Bill of Materials (BOM)

C.1 INTRODUCTION

This appendix includes the EVB-USB4624BCUH Evaluation Board Bill of Materials (BOM).

TABLE C-1: EVB-USB4624BCUH EVALUATION BOARD BILL OF MATERIALS

Item	Qty	Qty Populated	Reference Designator(s)	Description	Manufacturer	Manufacturer Part Number	Notes
1	2	2	C3, C6	Capacitor, Low ESR, 150 uF, 6.3 VDC, 20%, Aluminum, Radial-SMT, 5 mm x 5.7 mm	Lelon	VZS151M0JTR-0506	
2	2	2	C1, C2	Capacitor, 0.1 uF, 10%, 10V, X5R, 0402	Murata	GRM155R61E104KA87D	DISP-T
3	27	27	C4, C7, C8, C9, C11, C18, C19, C20, C23, C28, C33, C34, C36, C37, C39, C40, C42, C46, C47, C54, C55, C57, C59, C60, C63, C64, C73	Capacitor, 0.1 uF, 10%, 10V, X5R, 0402	Murata	GRM155R61E104KA87D	
4	2	2	C50, C51	Capacitor, 6 pF, 50V, ± 0.5 pF, NPO, 0402	Murata	GRM1555C1H6R0DZ01D	
5	3	3	C10, C12, C70	Capacitor, 1000 pF, 50V, 10%, X7R, 0402	Murata	GRM155R71H102KA01D	
6	10	10	C5, C13, C14, C21, C48, C49, C52, C53, C61, C66	Capacitor, 1.0 uF, 16 VDC, 10%, X5R, 0603	Murata	GRM188R61C105KA93D	
7	1	1	C72	Capacitor, 2.2 uF, 6.3 VDC, 10%, X5R, 0603	Murata	GRM185R60J225KE26D	
8	4	4	C29, C56, C58, C65	Capacitor, 10 uF, 6.3 VDC, 20%, X5R, 0603	Murata	GRM188R60J106ME47D	
9	8	8	C15, C17, C24, C27, C32, C35, C44, C62	Capacitor, 4.7 uF, 6.3 VDC, 20%, X5R, 0603	Murata	GRM188R60J475KE19D	
10	2	2	C68, C71	Capacitor, 10 uF, 25 VDC, 10%, 0805	Murata	GRM21BR61E106KA73L	
11	1	1	R46	Resistor, ZERO, 0.1W, 0402	Panasonic	ERJ-2GE0R00X	UART
12	3	3	R1, R2, R41	Resistor, 2.2K, 5%, 1/16W, 0603	Panasonic	ERJ-3GEYJ222V	
13	4	4	R3, R12, R13, R14	Resistor, 10K, 5%, 1/16W, 0603	Panasonic	ERJ-3GEYJ103V	
14	3	3	R34, R35, R40	Resistor, 10K, 5%, 1/16W, 0603	Panasonic	ERJ-3GEYJ103V	SPI
15	10	10	R4, R18, R19, R23, R28, R36, R37, R38, R39, R44	Resistor, 1K, 5%, 1/16W, 0603	Panasonic	ERJ-3GEYJ102V	
16	4	4	R5, R22, R42, R43	Resistor, 100K, 5%, 1/16W, 0603	Panasonic	ERJ-3GEYJ104V	
17	4	4	R6, R7, R21, R45	Resistor, 330, 5%, 1/16W, 0603	Panasonic	ERJ-3GEYJ331V	
18	2	2	R9, R11	Resistor, 5.76K, 1%, 1/16W, 0603	Rohm	MCR03EZHF5761	
19	2	2	R15, R16	Resistor, 100, 5%, 1/16W, 0603	Panasonic	ERJ-3GEYJ101V	
20	1	1	R17	Resistor, 432, 1%, 1/10W, 0603	SMECStackpole	RC73A2X4320FTF RMCF0603FT432R	
21	1	1	R25	Resistor, 12.0K, 1%, 1/16W, 0603	Panasonic	ERJ-3EKF1202V	
22	1	1	R26	Resistor, 1.91K, 1%, 1/10W, 0603	Stackpole Electronics	RMCF0603FT1K91	
23	1	1	R29	Resistor, 29.4K, 1%, 1/10W, 0603	Panasonic	ERJ-3EKF2942V	

TABLE C-1: EVB-USB4624BCUH EVALUATION BOARD BILL OF MATERIALS

Item	Qty	Qty Populated	Reference Designator(s)	Description	Manufacturer	Manufacturer Part Number	Notes
24	2	2	R30, R31	Resistor, 255, 1%, 1/10W, 0603	SMEC Panasonic	RC73A2X2550FTF ERJ-3EKF2550V	
25	2	2	R8, R10	Resistor, 0.020, 1%, 1/4W, 0805	Panasonic	ERJ-6BWJR020V	
26	1	1	D5	LED, Red, 3 mm, Diffused, 0.2" CL-vert, TH, Right Angle	Lumex	SSF-LXH103ID	
27	1	1	D3	LED, Red, 0804, Right Angle	Stanley Electric	BR1113F	
28	2	2	D4, D10	LED, Blue, 0804, Right Angle	Stanley Electric	DB1113F	
29	4	4	D1, D2, D11, D12	LED, Green, Bright (40 mcd), 0804, Right Angle	Stanley Electric	DG1113F	
30	3	3	D6, D8, D9	LED, Bright Yellow, 0804, Right Angle	Stanley Electric	FY1113F	
31	2	2	L1, L3	Inductor, 4.7 uH, Multi-layer, Shielded, 1100 mA, 0805	Murata	LQM2MPN4R7NG0L	9Vout
32	3	3	J4, J16, J21	Header, 1 x 2, 0.1 Inch, Vertical (Cut from 1x36 stock)	FCI	68000-236HLF	
33	2	2	J11, J19	Header, 1 x 3, 0.1 Inch, Vertical (Cut from 1x36 stock)	FCI	68000-236HLF	
34	4	4	J2, J3, J9, J10	Socket, 1 x 6, 0.1 Inch, Vertical, Female	Murata/Datel	4320-01074-0	Mtr_Down
35	1	1	J18	Header, 2 x 2, 0.1 Inch, Vertical (Cut from 2x36 stock)	FCI	67996-272HLF	
36	2	2	[J20, J23, J25], [J30, J34, J35]	Header, 2 x 3, 0.1 Inch, Vertical (Cut from 2x36 stock)	FCI	67996-272HLF	
37	1	1	[J22, J24, J26, J28]	Header, 2 x 4, 0.1 Inch, Vertical (Cut from 2x36 stock)	FCI	67996-272HLF	
38	1	1	J27	Header, 2 x 5, 0.1 Inch, Vertical (Cut from 2x36 stock)	FCI	67996-272HLF	
39	1	1	J32	Header, 2 x 5, 0.1 Inch, Right Angle, TH	Samtec	HTSW-1-05-25-L-D-RA	
40	2	2	J6, J8	Receptacle, USB, Style A, Right Angle, Through-hole	AMP	292303-1	
41	1	1	J39	Receptacle, USB, Style B, Right Angle, Through-hole	FCI	61729-x0xxBLF	
42	6	6	J12, J13, J14, J15, J27, J29	Receptacle, Coax, U.FL, SMT, Vertical	Hirose	U.FL-R-SMT-1	UFL
43	1	1	J36	Connector, Power Jack, 2.5 mm x 5.5 mm, 12V, 4A, Right Angle, TH	Cui Stack	PJ-002BH	
44	1	1	SW1	Switch, Momentary, SPST, 100 mA, J-lead, NO	E-Switch	TL3301xF160QJor-RJ	
45	1	1	SW2	Switch, DPDT, Slide, Sub-Mini, Top Actuator, TH	C&K	JS202011CQN	
46	6	6	U1, U7, U8, U16, U18, U19	IC, 74LVC1G14, Inverter, Shottky, DCK	TI	SN74LVC1G14DCKR	
47	1	1	U2	IC, TC1270ATVCT, MPU Supervisor, 3.08V Trip, Push-Pull, SOT23-5	Microchip	TC1270ATVCT	
48	2	2	U3, U5	IC, Current-Sense Amplifier, SOT23-5	Maxim	MAX9934FAUA+	
49	2	2	U4, U6	IC, MAX1562H, Power Distribution Switch, SO-8	Maxim	MAX1562HESA+	
50	3	3	U9, U13, U14	IC, DC-DC Converter Module, 0.591-6 Vout, ~12 Vin, 0.591-6 VDC out, 3A, 5 pin SIP, 0.41" Wide	Murata	OKR-T/3-W12-C	
51	1	1	U11	IC, USB4624, USB 2.0 and w/ HSIC, 4-port, QFN48	SMSC	USB4624_QFN48	

TABLE C-1: EVB-USB4624BCUH EVALUATION BOARD BILL OF MATERIALS

Item	Qty	Qty Populated	Reference Designator(s)	Description	Manufacturer	Manufacturer Part Number	Notes
52	1	1	U12	IC, DC-DC Converter Module, 0.591-6 Vout, ~12 Vin, 0.591-6 VDC out, 6A, 5 pin SIP, 0.41" Wide	Murata	OKR-T/6-W12-C	
53	1	1	U15	IC, MAX232E, 5V RS/TIA-232 Transceiver, SO16	TI	MAX232EID	
54	1	1	U17	IC, '25VF640C, 64 Mb (8M x 8) SPI Serial FLASH, 2.5V-3.6V, 75-80 MHz, Dual Read, SO8	Microchip	SST25VF064C-80-4I-S3AE	SPI
55	1	1	Y1	Crystal, 24.000 MHz, 30 ppm, 6pF, SMT 2.0 MM X 1.6 MM	Murata	XRCGB24M000F3M00R0	
56	2	2	JMP1 {J5 (pins 3-4)}, JMP2 {J7 (pins 3-4)}	Wire Jumper, 30 AWG or larger			EVB
57	4	4	n/a	Foot, Silicone Rubber, Adhesive, Clear, Hemispherical, .38"x.150"	3M Bumper Specialties Richco	SJ-5306 BS-12 RBS-12	EVB
58	1	1	n/a	Serial Number Labels: "Ces78 - ", L x W = 1" x 0.25" max	Assembler	Label_SN_EVB-USB4624BCUH_A1	
59	1	1	n/a	Assembly Labels: "EVB-USB4624BCUH_A1", L x W = 1" x 0.25"	Assembler	Label_Asy_EVB-USB4624BCUH_A1	
60	1	1	PCB Fab	PCB, Demo-USB4624QFN48BC (EVB-USB4624BCUH)	Advanced Circuits	PCB-Demo-USB4624QFN48BC_A	
61	1	1	Assembly	Assembly, Demo-USB4624QFN48BC (EVB-USB4624BCUH), Rev A1		Assy-Demo-USB4624QFN48BC_A1	
62	1	0	C16	Capacitor, Low ESR, 150 uF, 6.3VDC, 20%, Aluminum, Radial-SMT, 5 mm x 5.7 mm	Lelon	VZS151M0JTR-0506	DNP
63	1	0	C69	Capacitor, Low ESR, 180 uF, 16VDC, 20%, Aluminum, Radial, 6.3 x 15 mm	Nichicon	UPW1C181MED	DNP
64	1	0	C41	Capacitor, 0.01 uF, 16V, 10%, X7R, 0402	Murata	GRM155R71E103KA01D	9Vout
65	1	0	C22	Capacitor, 0.1 uF, 10%, 25V, X5R, 0402 (Must be 25V)	Murata	GRM155R61E104KA87D	9Vout
66	2	0	C45, C67	Capacitor, 0.1 uF, 10%, 10V, X5R, 0402	Murata	GRM155R61E104KA87D	Reg_Dly
67	2	0	C25, C43	Capacitor, 1.0 uF, 16 VDC, 10%, X5R, 0603	Murata	GRM188R61C105KA93D	DNP
68	1	0	C38	Capacitor, 4.7 uF, 6.3 VDC, 20%, X5R, 0603	Murata	GRM188R60J475KE19D	DNP
69	3	0	C26, C30, 31	Capacitor, 10 uF, 25 VDC, 10%, 0805	Murata	GRM21BR61E106KA73L	9Vout
70	2	0	R32, R33	Resistor, ZERO, 0.1W, 0402	Panasonic	ERJ-2GE0R00X	SMA0
71	1	0	R20	Resistor, 100K, 5%, 1/16W, 0603	Panasonic	ERJ-3GEYJ104V	No
72	1	0	R24	Resistor, 4.99K, 1%, 1/10W, 0603	KOA Speer	RK73H1JTTD4991F	9Vout
73	1	0	R27	Resistor, 51.1K, 1%, 1/10W, 0603	SMECStackpole	RC73A2X5112FTF RMCF0603FT51K1	9Vout

TABLE C-1: EVB-USB4624BCUH EVALUATION BOARD BILL OF MATERIALS

Item	Qty	Qty Populated	Reference Designator(s)	Description	Manufacturer	Manufacturer Part Number	Notes
74	1	0	D7	Diode, Schottky, B240A-13, 40V, 2.0A, KA, SMA	Diodes Inc.	B240A-13	9Vout
75	1	0	L2	Inductor, 4.7 uH, Multi-layer, Shielded, 1100mA, 0805	Murata	LQM2MPN4R7NG0L	9Vout
76	1	0	J33	Header, 1 x 2, 0.1 Inch, Vertical (Cut from 1x36 stock)	FCI	68000-236HLF	DNP
77	1	0	J17	Header, 1 x 2, 0.1 Inch, Vertical (Cut from 1x36 stock)	FCI	68000-236HLF	9Vout
78	1	0	J31	Header, 1 x 2, 0.1 Inch, Vertical (Cut from 1x36 stock)	FCI	68000-236HLF	DNP
79	1	0	J1	Header, 1 x 5, 0.1 Inch, Vertical (Cut from 1x36 stock)	FCI	68000-236HLF	DNP
80	1	0	J41	Header, 1 x 4, 0.2 Inch, Shrouded, Polarized, Right Angle	Molex	15-24-4441	PC
81	2	0	J5, J7	Header, 2 x 3, 0.1 Inch, Vertical (Cut from 2x36 stock)	FCI	67996-272HLF	DNP
82	2	0	J38, J40	Receptacle, SMA, Edge Mount	Connector City	CON SMA003.062	SMA0
83	2	0	Mtr1, Mtr2	Meter, Panel, 20V, Blue LED, 12 pin TH	Murata	DMS-20PC-2-BS-C DMS-20PC-2-BL-C	2nd OPS
84	1	0	U10	IC, Buck Switching Converter, 1.4Mhz, 1.2A, SOT23-6	Monolithic Power Systems	MP2359DT-LF-P	9Vout
85	7	0	SHUNT1-SHUNT7	Shunt, Insulated, 0.1 Inch	AMP	881545-2	2nd OPS

NOTES:



MICROCHIP

Worldwide Sales and Service

AMERICAS

Corporate Office
2355 West Chandler Blvd.
Chandler, AZ 85224-6199
Tel: 480-792-7200
Fax: 480-792-7277
Technical Support:
<http://www.microchip.com/support>
Web Address:
www.microchip.com

Atlanta
Duluth, GA
Tel: 678-957-9614
Fax: 678-957-1455

Austin, TX
Tel: 512-257-3370

Boston
Westborough, MA
Tel: 774-760-0087
Fax: 774-760-0088

Chicago
Itasca, IL
Tel: 630-285-0071
Fax: 630-285-0075

Cleveland
Independence, OH
Tel: 216-447-0464
Fax: 216-447-0643

Dallas
Addison, TX
Tel: 972-818-7423
Fax: 972-818-2924

Detroit
Novi, MI
Tel: 248-848-4000

Houston, TX
Tel: 281-894-5983

Indianapolis
Noblesville, IN
Tel: 317-773-8323
Fax: 317-773-5453

Los Angeles
Mission Viejo, CA
Tel: 949-462-9523
Fax: 949-462-9608

New York, NY
Tel: 631-435-6000

San Jose, CA
Tel: 408-735-9110

Canada - Toronto
Tel: 905-673-0699
Fax: 905-673-6509

ASIA/PACIFIC

Asia Pacific Office
Suites 3707-14, 37th Floor
Tower 6, The Gateway
Harbour City, Kowloon
Hong Kong
Tel: 852-2401-1200
Fax: 852-2401-3431

Australia - Sydney
Tel: 61-2-9868-6733
Fax: 61-2-9868-6755

China - Beijing
Tel: 86-10-8569-7000
Fax: 86-10-8528-2104

China - Chengdu
Tel: 86-28-8665-5511
Fax: 86-28-8665-7889

China - Chongqing
Tel: 86-23-8980-9588
Fax: 86-23-8980-9500

China - Hangzhou
Tel: 86-571-2819-3187
Fax: 86-571-2819-3189

China - Hong Kong SAR
Tel: 852-2943-5100
Fax: 852-2401-3431

China - Nanjing
Tel: 86-25-8473-2460
Fax: 86-25-8473-2470

China - Qingdao
Tel: 86-532-8502-7355
Fax: 86-532-8502-7205

China - Shanghai
Tel: 86-21-5407-5533
Fax: 86-21-5407-5066

China - Shenyang
Tel: 86-24-2334-2829
Fax: 86-24-2334-2393

China - Shenzhen
Tel: 86-755-8864-2200
Fax: 86-755-8203-1760

China - Wuhan
Tel: 86-27-5980-5300
Fax: 86-27-5980-5118

China - Xian
Tel: 86-29-8833-7252
Fax: 86-29-8833-7256

China - Xiamen
Tel: 86-592-2388138
Fax: 86-592-2388130

China - Zhuhai
Tel: 86-756-3210040
Fax: 86-756-3210049

ASIA/PACIFIC

India - Bangalore
Tel: 91-80-3090-4444
Fax: 91-80-3090-4123

India - New Delhi
Tel: 91-11-4160-8631
Fax: 91-11-4160-8632

India - Pune
Tel: 91-20-3019-1500

Japan - Osaka
Tel: 81-6-6152-7160
Fax: 81-6-6152-9310

Japan - Tokyo
Tel: 81-3-6880-3770
Fax: 81-3-6880-3771

Korea - Daegu
Tel: 82-53-744-4301
Fax: 82-53-744-4302

Korea - Seoul
Tel: 82-2-554-7200
Fax: 82-2-558-5932 or
82-2-558-5934

Malaysia - Kuala Lumpur
Tel: 60-3-6201-9857
Fax: 60-3-6201-9859

Malaysia - Penang
Tel: 60-4-227-8870
Fax: 60-4-227-4068

Philippines - Manila
Tel: 63-2-634-9065
Fax: 63-2-634-9069

Singapore
Tel: 65-6334-8870
Fax: 65-6334-8850

Taiwan - Hsin Chu
Tel: 886-3-5778-366
Fax: 886-3-5770-955

Taiwan - Kaohsiung
Tel: 886-7-213-7830

Taiwan - Taipei
Tel: 886-2-2508-8600
Fax: 886-2-2508-0102

Thailand - Bangkok
Tel: 66-2-694-1351
Fax: 66-2-694-1350

EUROPE

Austria - Wels
Tel: 43-7242-2244-39
Fax: 43-7242-2244-393

Denmark - Copenhagen
Tel: 45-4450-2828
Fax: 45-4485-2829

France - Paris
Tel: 33-1-69-53-63-20
Fax: 33-1-69-30-90-79

Germany - Dusseldorf
Tel: 49-2129-3766400

Germany - Munich
Tel: 49-89-627-144-0
Fax: 49-89-627-144-44

Germany - Pforzheim
Tel: 49-7231-424750

Italy - Milan
Tel: 39-0331-742611
Fax: 39-0331-466781

Italy - Venice
Tel: 39-049-7625286

Netherlands - Drunen
Tel: 31-416-690399
Fax: 31-416-690340

Poland - Warsaw
Tel: 48-22-3325737

Spain - Madrid
Tel: 34-91-708-08-90
Fax: 34-91-708-08-91

Sweden - Stockholm
Tel: 46-8-5090-4654

UK - Wokingham
Tel: 44-118-921-5800
Fax: 44-118-921-5820

10/28/13