

DG0633
Demo Guide
IGLOO2 FPGA CoreTSE MAC 1000 Base-T Loopback
Demo



a  MICROCHIP company



a  MICROCHIP company

Microsemi Headquarters

One Enterprise, Aliso Viejo,
CA 92656 USA

Within the USA: +1 (800) 713-4113

Outside the USA: +1 (949) 380-6100

Sales: +1 (949) 380-6136

Fax: +1 (949) 215-4996

Email: sales.support@microsemi.com

www.microsemi.com

©2021 Microsemi, a wholly owned subsidiary of Microchip Technology Inc. All rights reserved. Microsemi and the Microsemi logo are registered trademarks of Microsemi Corporation. All other trademarks and service marks are the property of their respective owners.

Microsemi makes no warranty, representation, or guarantee regarding the information contained herein or the suitability of its products and services for any particular purpose, nor does Microsemi assume any liability whatsoever arising out of the application or use of any product or circuit. The products sold hereunder and any other products sold by Microsemi have been subject to limited testing and should not be used in conjunction with mission-critical equipment or applications. Any performance specifications are believed to be reliable but are not verified, and Buyer must conduct and complete all performance and other testing of the products, alone and together with, or installed in, any end-products. Buyer shall not rely on any data and performance specifications or parameters provided by Microsemi. It is the Buyer's responsibility to independently determine suitability of any products and to test and verify the same. The information provided by Microsemi hereunder is provided "as is, where is" and with all faults, and the entire risk associated with such information is entirely with the Buyer. Microsemi does not grant, explicitly or implicitly, to any party any patent rights, licenses, or any other IP rights, whether with regard to such information itself or anything described by such information. Information provided in this document is proprietary to Microsemi, and Microsemi reserves the right to make any changes to the information in this document or to any products and services at any time without notice.

About Microsemi

Microsemi, a wholly owned subsidiary of Microchip Technology Inc. (Nasdaq: MCHP), offers a comprehensive portfolio of semiconductor and system solutions for aerospace & defense, communications, data center and industrial markets. Products include high-performance and radiation-hardened analog mixed-signal integrated circuits, FPGAs, SoCs and ASICs; power management products; timing and synchronization devices and precise time solutions, setting the world's standard for time; voice processing devices; RF solutions; discrete components; enterprise storage and communication solutions, security technologies and scalable anti-tamper products; Ethernet solutions; Power-over-Ethernet ICs and midspans; as well as custom design capabilities and services. Learn more at www.microsemi.com.

Contents

1	Revision History	1
1.1	Revision 4.0	1
1.2	Revision 3.0	1
1.3	Revision 2.0	1
1.4	Revision 1.0	1
2	IGLOO2 FPGA CoreTSE MAC 1000 Base-T Loopback Demo	2
2.1	Design Requirements	3
2.2	Prerequisites	3
2.3	Demo Design	3
2.3.1	Demo Design Features	4
2.3.2	Demo Design Description	6
2.4	Simulating the Design	6
2.4.1	Simulation	6
2.5	Setting Up the Demo Design	10
2.6	Programming the Device	10
2.6.1	Connecting IGLOO2 Evaluation Kit Board to Host PC	11
2.6.2	Running the Demo Design with Cat Karat and Wireshark on the Hardware	12
3	Appendix 1: Programming the Device Using FlashPro Express	15
4	Appendix 2: Running the Demo Design Using Spirent Test Center	18

Figures

Figure 1	Demo Design Files Top-Level Structure	4
Figure 2	IGLOO2 CoreTSE MAC 1000 Base-T Loopback Demo	4
Figure 3	Libero SmartDesign	6
Figure 4	SmartDesign for Simulation	7
Figure 5	Libero SmartDesign Top Module	8
Figure 6	ModelSim Transcript Messages	8
Figure 7	Simulation Window-Transmitted Ethernet Packet	9
Figure 8	Simulation Window-Received Ethernet Packet	9
Figure 9	IGLOO2 Evaluation Kit Setup	11
Figure 10	Wireshark Network Analyzer	12
Figure 11	Cat Karat Packet Generate Window	13
Figure 12	Packet Flow Control	13
Figure 13	Wireshark Software Window	14
Figure 14	FlashPro Express Job Project	15
Figure 15	New Job Project from FlashPro Express Job	16
Figure 16	Programming the Device	16
Figure 17	FlashPro Express—RUN PASSED	17
Figure 18	Spirent Test Center Stream Block – General Tab	18
Figure 19	Spirent Test Center	19
Figure 20	Spirent Test Center Stream Block – Frame Tab	19

Tables

Table 1	Design Requirements	3
Table 2	IGLOO2 FPGA Evaluation Kit Jumper Settings	10

1 Revision History

The revision history describes the changes that were implemented in the document. The changes are listed by revision, starting with the most current publication.

1.1 Revision 4.0

The following is a summary of the changes made in this revision.

- Updated the document for Libero SoC v2021.1.
- Removed the references to Libero version numbers.

1.2 Revision 3.0

The following is a summary of the changes in revision 3.0 of this document.

- Libero SoC and FlashPro design requirements were updated. For more information, refer to the [Design Requirements](#), page 3.
- Throughout the document, all the associated figures were updated.

1.3 Revision 2.0

In revision 2.0 of this document, updated the document for Libero SoC v11.7 software release.

1.4 Revision 1.0

Revision 1.0 was the first publication of this document.

2 IGLOO2 FPGA CoreTSE MAC 1000 Base-T Loopback Demo

Microsemi Core Triple-Speed Ethernet (CoreTSE) Media Access Controller (MAC) IP is a configurable soft Intellectual Property (IP) core that complies with the IEEE 802.3 standard. This demo design provides an Ethernet solution for the IGLOO2 FPGA and implements a CoreTSE MAC -based 1000 Base-T loopback design on the IGLOO2 Evaluation Kit.

CoreTSE MAC enables system designers to implement a broad range of Ethernet designs, from low-cost 10/100 Ethernet to higher-performance 1 gigabit ports. CoreTSE MAC suits networking equipment such as switches, routers, and data acquisition systems. CoreTSE MAC is also available in a version that works with SmartFusion[®]2 System-on-Chip (SoC) FPGA family.

The CoreTSE MAC has the following interfaces:

- 10/100/1000 Mbps Ethernet MAC with a Gigabit Media Independent Interface (GMII) and Ten Bit Interface (TBI) to support Serial Gigabit Media Independent Interface (SGMII), 1000BASE-T, and 1000BASE-X
- GMII or TBI physical layer interface connects to Ethernet PHY
- MAC data path interface
- Advanced Peripheral Bus (APB) slave interface for MAC configuration registers and status counter access

The CoreTSE MAC can be configured as GMII or TBI for an Ethernet network at 10/100/1000 Mbps data transfer rates (line speeds).

The CoreTSE MAC is available in two different versions:

- CoreTSE_AHB: Uses the AHB interface for both the transmit and receive paths. This IP works for SmartFusion2 SoC FPGA.
- CoreTSE (Non-AMBA): Uses direct access to the MAC with a streaming packet interface. This IP works for IGLOO2 FPGA and SmartFusion2 SoC FPGA.

CoreTSE and CoreTSE_AHB are identical to MSS hard Ethernet MAC in SmartFusion2 for the supported features, register configuration, and register addresses. Multiple CoreTSE MAC IPs can be used in IGLOO2 to achieve Ethernet solutions. CoreTSE MAC can be used in SmartFusion2 devices along with MSS Ethernet MAC to support multiple Ethernet interfaces. For more information about CoreTSE MAC, refer to the *CoreTSE Handbook*.

For more information about Ethernet applications, refer to the *AC423: SmartFusion2/IGLOO2 Ethernet Application Note*.

Note: CoreTSE MAC requires license for using in Libero[®] System-on-Chip (SoC) design. For license request, send an email to soc_marketing@microsemi.com.

2.1 Design Requirements

The following table lists the design requirements for running the demo.

Table 1 • Design Requirements

Requirement	Version
Operating System	64 bit Windows 7 and 10
Hardware	
IGLOO2 Evaluation Kit:	Rev D or later
<ul style="list-style-type: none"> • 12 V adapter • FlashPro4 programmer 	
Spirent Test Center (Optional)	
Software	
Libero SoC	Note: Refer to the <code>readme.txt</code> file provided in the design files for the software versions used with this reference design.
FlashPro Express	
Cat Karat Packet Generator Software	Provided with design files
Wireshark Software	Provided with design files
IP	
CoreTSE MAC	License provided on request

Note: Libero SmartDesign and configuration screen shots shown in this guide are for illustration purpose only. Open the Libero design to see the latest updates.

2.2 Prerequisites

Before you start:

1. Download and install Libero SoC (as indicated in the website for this design) on the host PC from the following location: <https://www.microsemi.com/product-directory/design-resources/1750-libero-soc>
2. For demo design files download link:
http://soc.microsemi.com/download/rsc/?f=m2gl_dg0633_df

2.3 Demo Design

The demo design files include:

- Libero project
- Programming files
- Source files
- Readme.txt file

Refer to the `Readme.txt` file for the complete directory structure.

The following figure shows the top-level structure of the design files.

Figure 1 • Demo Design Files Top-Level Structure

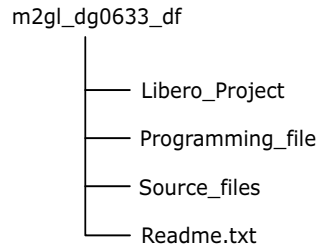

The following figure shows the demo design block diagram.

Figure 2 • IGLOO2 CoreTSE MAC 1000 Base-T Loopback Demo

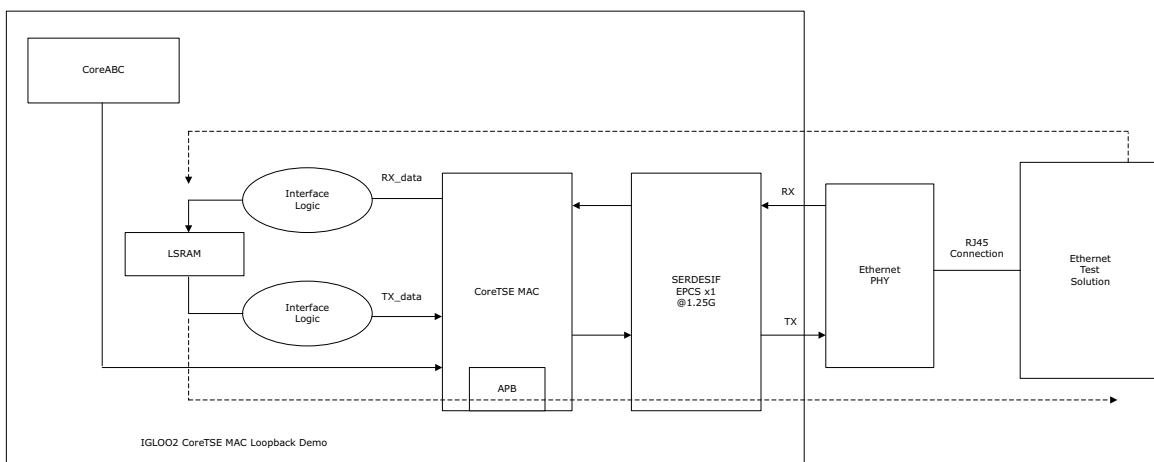

In this demo design, CoreTSE MAC is instantiated in the FPGA fabric and connected to the on-board Ethernet PHY using the high-speed serial interface (SERDES_IF).

In the previous figure, the dotted arrow in red shows the transfer of an Ethernet packet from the host PC to the internal LSRAM, and the dotted arrow in blue shows the retransmission of the packet from LSRAM to the host.

2.3.1 Demo Design Features

The demo design performs Ethernet loopback using CoreTSE MAC in TBI 1000Base-T on hardware and also in simulation.

Following are the demo design features:

- Simulation model for CoreTSE MAC loopback design.
- CoreTSE MAC loopback design on IGLOO2 Evaluation Kit.

The following section explains the initialization and configuration of CoreTSE MAC, SERDES_IF, and the loopback mechanism.

2.3.1.1 CoreTSE IP MAC Initialization

CoreTSE MAC is configured in TBI mode. The CoreABC soft-core is used to initialize CoreTSE MAC in 1000 Base-T and on-board Ethernet PHY.

Note: CoreABC is a Microsemi RISC processor that is implemented in logic gates. The CoreABC IP is available in the Libero SoC software IP tools catalog.

2.3.1.2 High-Speed Serial Interface Configuration

The high-speed SERDES_IF is configured in the External Physical Coding Sub layer (EPCS) mode lane 3 in the Libero GUI and is connected between CoreTSE MAC and on-board Ethernet PHY.

2.3.1.3 Ethernet Packet Loopback

The following Ethernet loopback mechanism is used in this demo:

2.3.1.3.1 Ethernet Packet Reception

The CoreTSE MAC receives the Ethernet packet from on-board Ethernet PHY through high-speed SERDES_IF.

The CoreTSE MAC receive (RX) path is connected to LSRAM through the receive interface logic. This interface logic is implemented in Verilog RTL and is used to keep the packet on to LSRAM memory.

2.3.1.3.2 Ethernet Packet Transmission

To loopback, the Ethernet packet, the interface logic implemented in Verilog RTL reads the Ethernet packet data from LSRAM memory and keeps it on CoreTSE MAC transmit (TX) path.

CoreTSE MAC transmits the Ethernet packet to on-board Ethernet PHY through high-speed SERDES.

2.3.1.4 Ethernet Test Solution

There are many ways to evaluate the CoreTSE MAC 1000 Base-T loopback demo on the IGLOO2 Evaluation Board.

2.3.1.4.1 Solution 1

- The Cat Karat packet generator software installed on the host PC is used to transmit the Ethernet packet through RJ45 Ethernet copper cable.
- The Wireshark packet receiver software installed on the host PC captures the Ethernet packet (loopback) through RJ45 Ethernet copper cable.

2.3.1.4.2 Solution 2

Spirent test center or an equivalent solution can be used to test the CoreTSE MAC loopback demo. For more information, refer to the [Appendix 2: Running the Demo Design Using Spirent Test Center](#), page 18.

The following figure and Figure 5, page 8 show the Libero SmartDesign to simulate the CoreTSE MAC loopback demo design. The simulation testbench has the following Libero components:

- CoreTSE MAC
- High-speed SERDES_IF
- Testbench with packet transmit and packet receive logic

The testbench smart design module reads the Ethernet packet from the packetfile.txt file and sends it to the IGLOO2 CoreTSE MAC loopback design through a high-speed serial interface. The loopback Ethernet packet is received by the testbench through the high-speed serial interface. ModelSim displays the received Ethernet packet on the transcript window. This completes the Ethernet packet loopback simulation.

Figure 4 • SmartDesign for Simulation

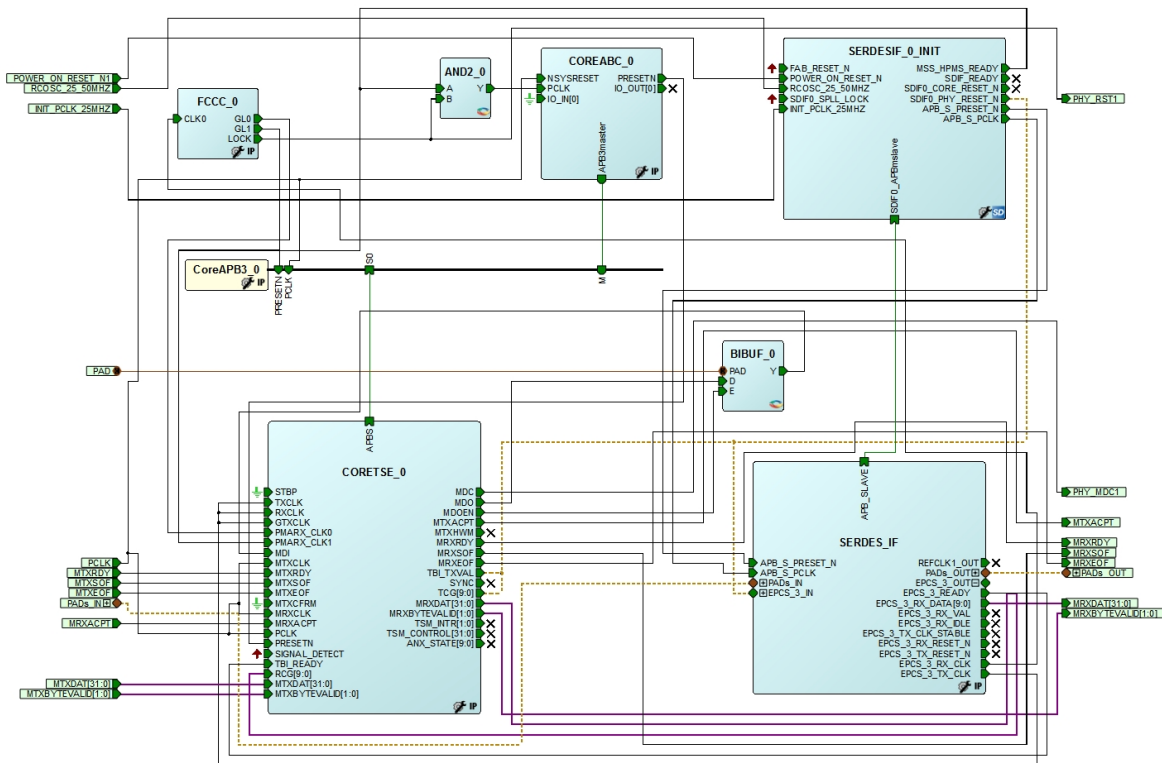

The Libero SmartDesign top module contains the CoreTSE MAC loopback design and the testbench module.

Figure 5 • Libero SmartDesign Top Module

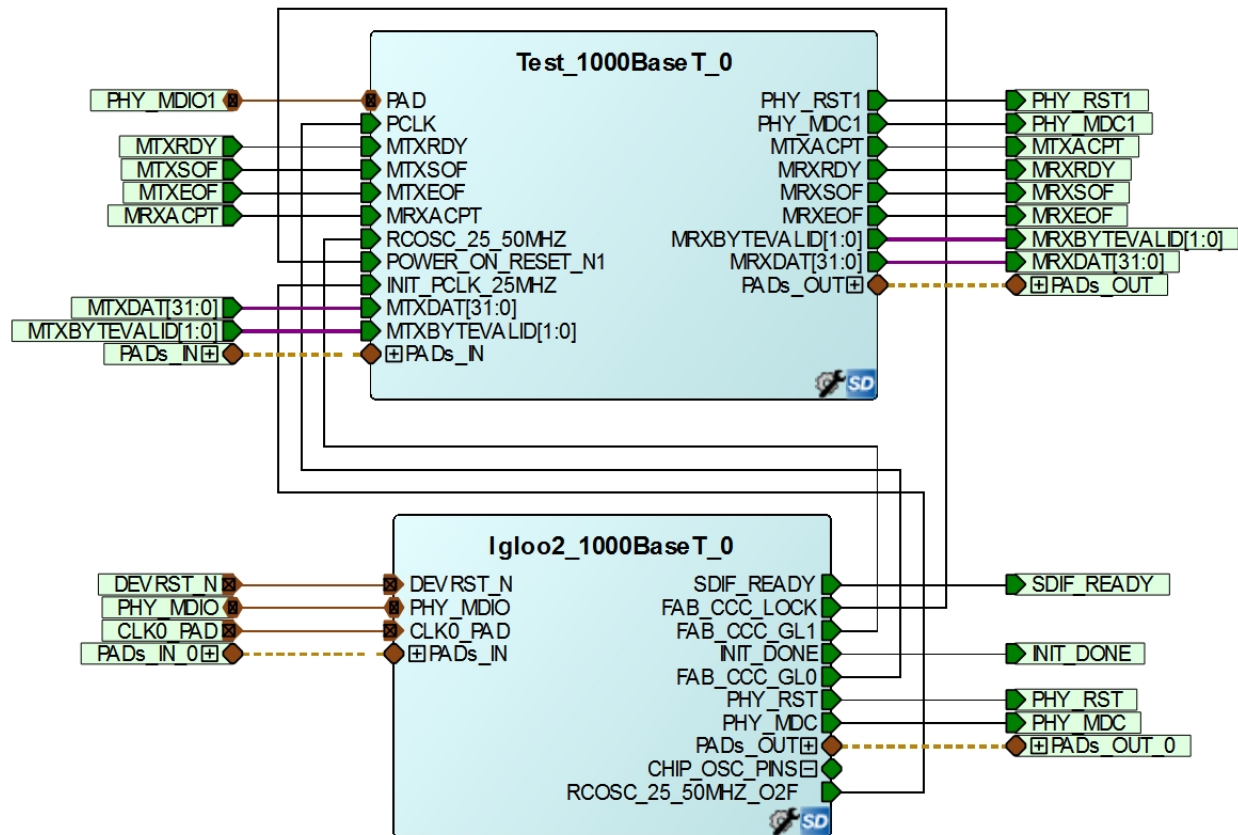

The following steps describe how to simulate the demo:

1. Open the Libero project from the following design files:
m2gl_dg0633_df\Libero_Project\Simulation\CoreTSE_1000BaseT_Demo\Libero_Project.prjx.
2. In the **Design Flow** tab, under **Verify Pre-Synthesized Design**, double-click **Simulate**. ModelSim runs the design for 180 μ s. The following figure shows the received Ethernet packet information displayed on the **ModelSim Transcript** window.

Figure 6 • ModelSim Transcript Messages

```

Transcript
# Simulation results may not be accurate.
# Instance: cb_testbench.CoreTSE_Top_0.CoreTSE_1000BaseT_0.FCCX1_CCC_INST.u_p11.u_p11.MAIN. Simulation time is 22604490 ps
# *****
# PHY TX DRIVER : Transmitting Data : t_setting_diff= 0
# PHY TX DRIVER : Electrical Idle I : t_setting_diff= 15
# PHY TX DRIVER : Transmitting Data : t_setting_diff= 0
# NVM_0: User Read Data: 32'h80240004 : Mem Address: 8b8 : Time: 144730 ns
# NVM_0: User Read Data: 32'h40022000 : Mem Address: 8bc : Time: 144800 ns
# NVM_0: User Read Data: 32'h00000003 : Mem Address: 8c0 : Time: 144930 ns
# Packet_frame = 55555555 ;
# Packet_frame = 55555555 ;
# Packet_frame = da020304 ;
# Packet_frame = 05065a02 ;
# Packet_frame = 03040506 ;
# Packet_frame = 002e0102 ;
# Packet_frame = 03040506 ;
# Packet_frame = 0708090a ;
# Packet_frame = 0b0c0d0e ;
# Packet_frame = 0f101112 ;
# Packet_frame = 13141516 ;
# Packet_frame = 1718191a ;
# Packet_frame = 1b1c1d1e ;
# Packet_frame = 1f202122 ;
# Packet_frame = 23242526 ;
# Packet_frame = 2728292a ;
# Packet_frame = 2b2c2d2e ;
# Packet_frame = 1419d1dc ;
WSIM Z>
    
```

The following figure and Figure 8, page 9 show the Waveform window. The highlighted portion shows the transmitted and received Ethernet packets.

Figure 7 • Simulation Window-Transmitted Ethernet Packet

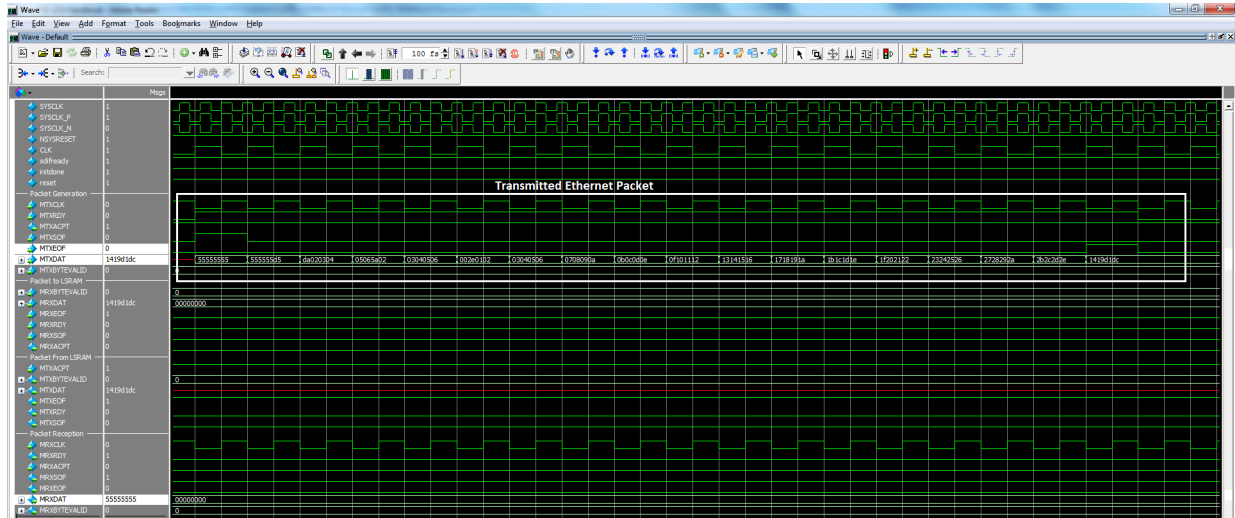
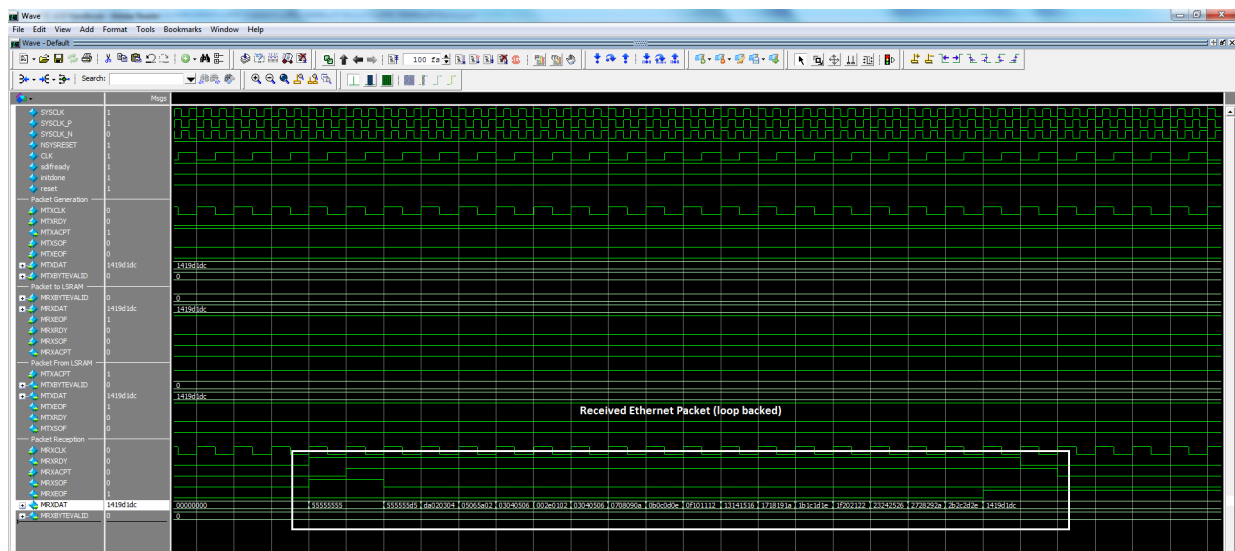

Figure 8 • Simulation Window-Received Ethernet Packet



2.5 Setting Up the Demo Design

The following steps describe how to setup the demo:

1. Connect the jumpers to the IGLOO2 FPGA Evaluation Kit board, as shown in the following table.
2. Connect the power supply to the J6 connector and switch ON.
3. Connect the FlashPro4 Programmer to the J5 connector on the IGLOO2 FPGA Evaluation Kit board.

Note: Ensure that the power supply switch SW7 is switched off while connecting the jumpers to the IGLOO2 FPGA Evaluation Kit.

Table 2 • IGLOO2 FPGA Evaluation Kit Jumper Settings

Jumper	Pin (From)	Pin (To)	Comments
J22	1	2	Default
J23	1	2	Default
J24	1	2	Default
J8	1	2	Default
J3	1	2	Default

2.6 Programming the Device

Program the IGLOO2 Evaluation Kit board with the job file provided as part of the design files using FlashPro Express software, refer to the [Appendix 1: Programming the Device Using FlashPro Express](#), page 15.

2.6.1 Connecting IGLOO2 Evaluation Kit Board to Host PC

The following steps describe how to connect the IGLOO2 Evaluation Kit Board to the host PC:

1. After successful programming, switch OFF the IGLOO2 Evaluation Kit Board.
2. Connect the host PC to the J13 connector on the IGLOO2 Evaluation Kit using the RJ45 cable.

The following figure shows the IGLOO2 Evaluation Kit board setup.

Figure 9 • IGLOO2 Evaluation Kit Setup

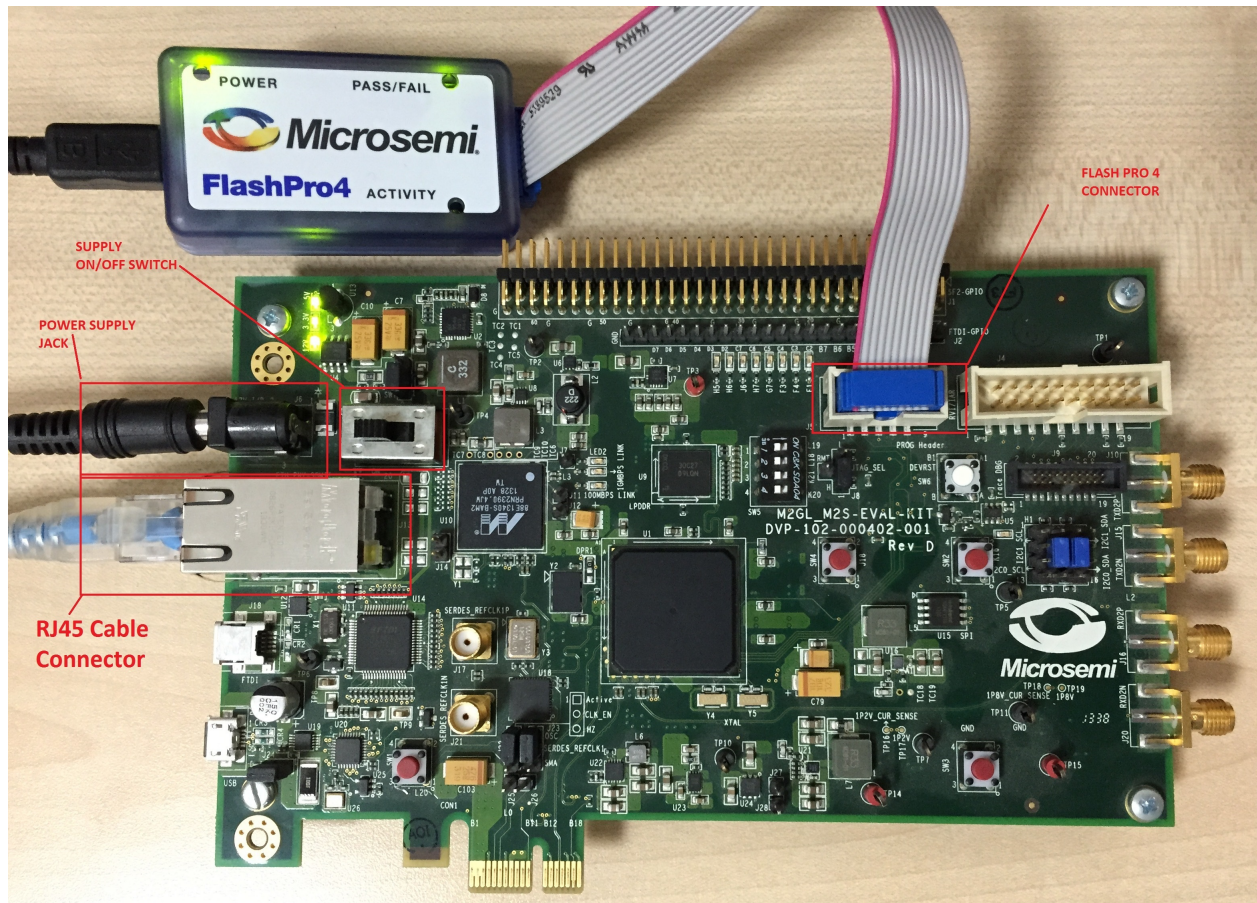

2.6.2 Running the Demo Design with Cat Karat and Wireshark on the Hardware

The following steps describe how to run the demo design:

1. Switch ON the power supply switch, **SW7**.
2. Install the Cat Karat packet software and Wireshark software on the host PC from the source files. (m2gl_dg0633_df\Source files)
3. On the host PC, open the Wireshark network analyzer. Select **Start**, as shown in Figure 10, page 12.

Figure 10 • Wireshark Network Analyzer

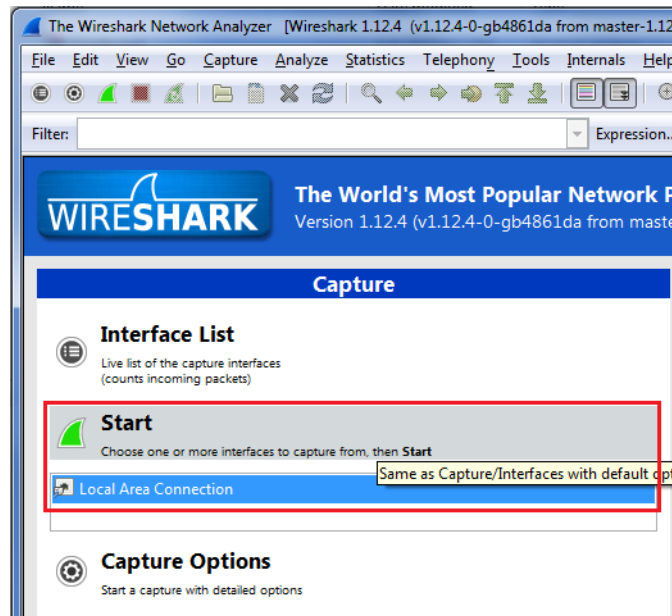

4. On the host PC, open the Cat Karat software, as shown in the following figure.

Figure 11 • Cat Karat Packet Generate Window

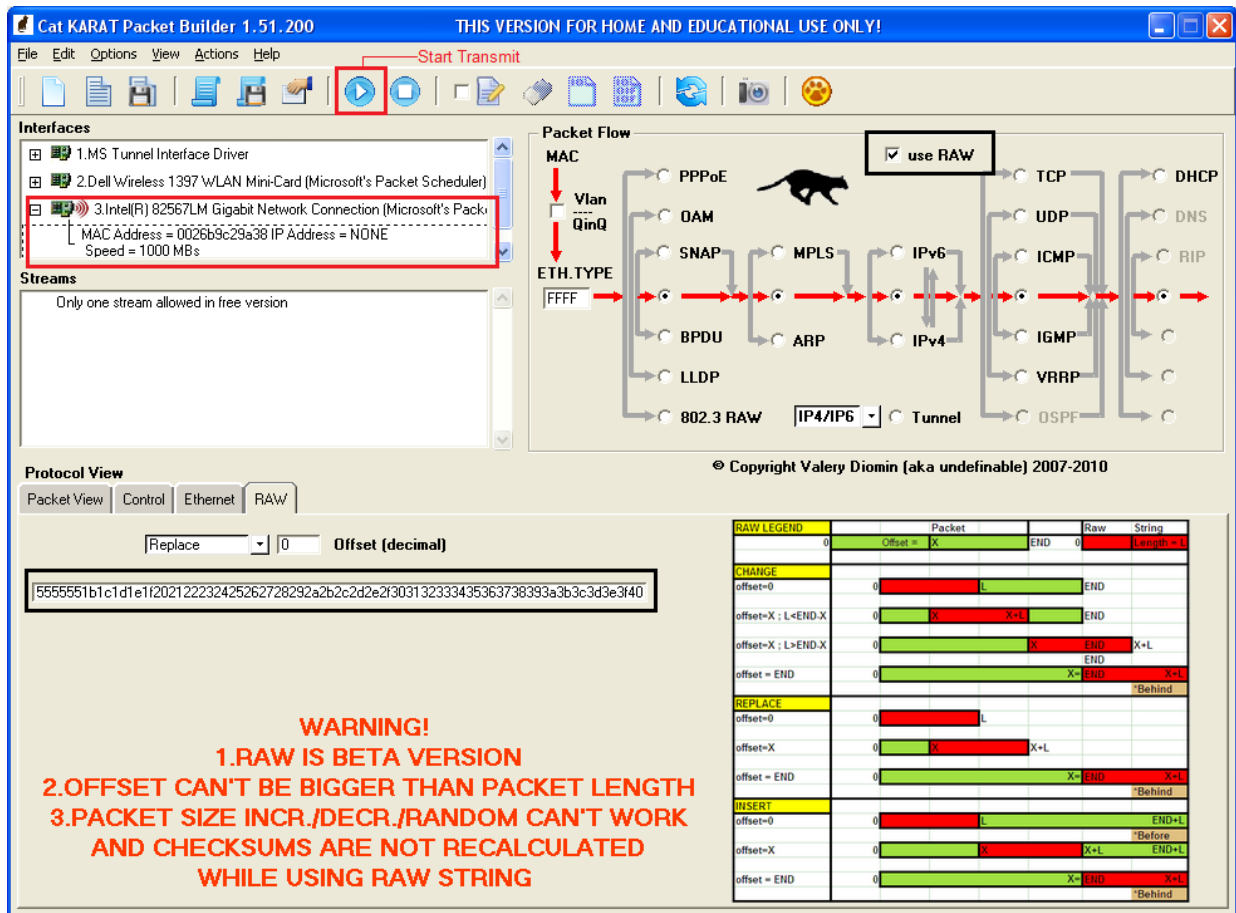

- Under Protocol View, click **Control** tab and enter the value 1 for Packets per Burst, as shown in Figure 12, page 13.

Figure 12 • Packet Flow Control

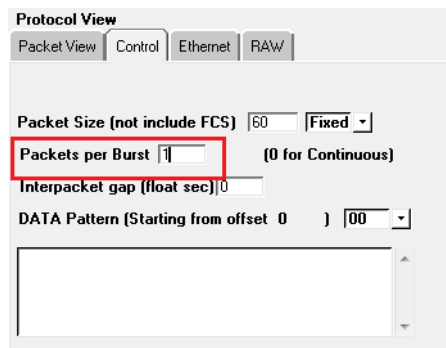

- Under **Packet Flow**, click **use RAW**, as shown in Figure 11, page 13.
- Under **Protocol View**, select the **RAW** tab and copy and paste the Ethernet net packet from the source files (m2gl_dg0633_df\Source_files\Raw_frame.txt) as shown in Figure 11, page 13.
- Under **Interfaces**, select the Ethernet connection to the IGLOO2 Evaluation Board.
- Select **Start Transmit** from the menu, as shown in Figure 11, page 13, to transmit the packet.
- In the Wireshark software window, double-click Ethernet-II, as shown in the following figure. The transmitted and received Ethernet packets are displayed.

Figure 13 • Wireshark Software Window

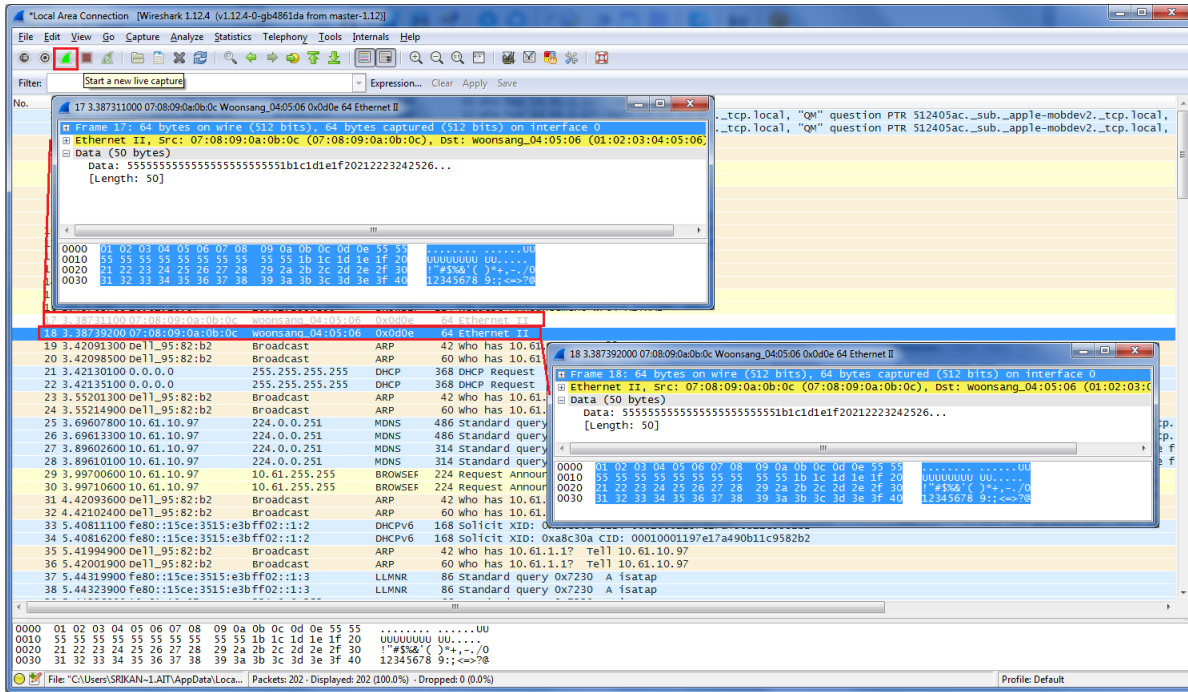

3 Appendix 1: Programming the Device Using FlashPro Express

This section describes how to program the IGLOO2 device with the programming job file using FlashPro Express.

To program the device, perform the following steps:

1. Ensure that the jumper settings on the board are the same as those listed in Table 2, page 10.

Note: The power supply switch must be switched off while making the jumper connections.

2. Connect the power supply cable to the **J6** connector on the board.
3. Power **ON** the power supply switch **SW7**.
4. On the host PC, launch the **FlashPro Express** software.
5. Click **New** or select **New Job Project from FlashPro Express Job** from **Project** menu to create a new job project, as shown in the following figure.

Figure 14 • FlashPro Express Job Project

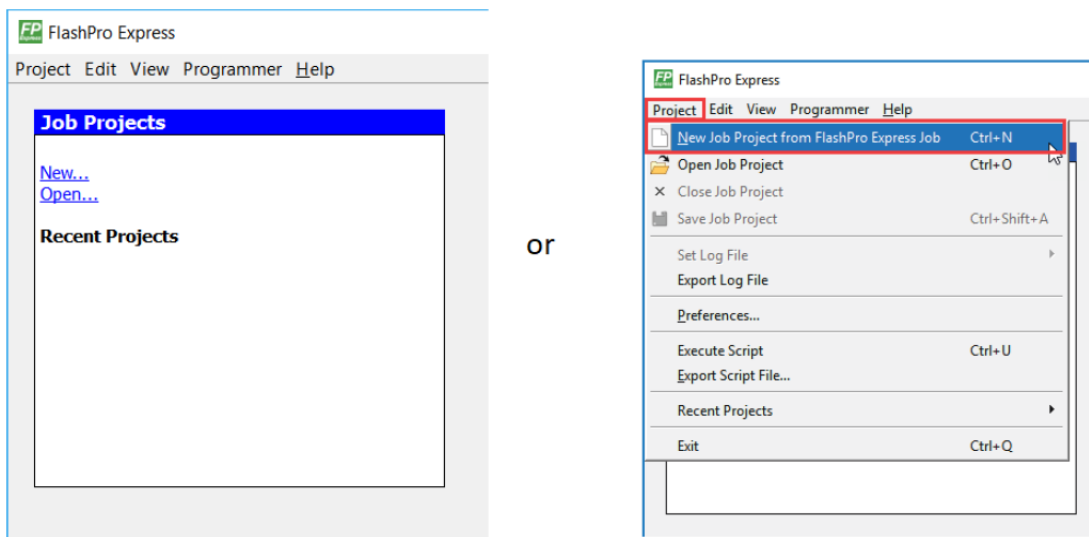

6. Enter the following in the **New Job Project from FlashPro Express Job** dialog box:
 - **Programming job file:** Click **Browse**, and navigate to the location where the .job file is located and select the file. The default location is: `<download_folder>\m2g1_dg0633_df\Programming file`
 - **FlashPro Express job project name:** Click **Browse** and navigate to the location where you want to save the project.

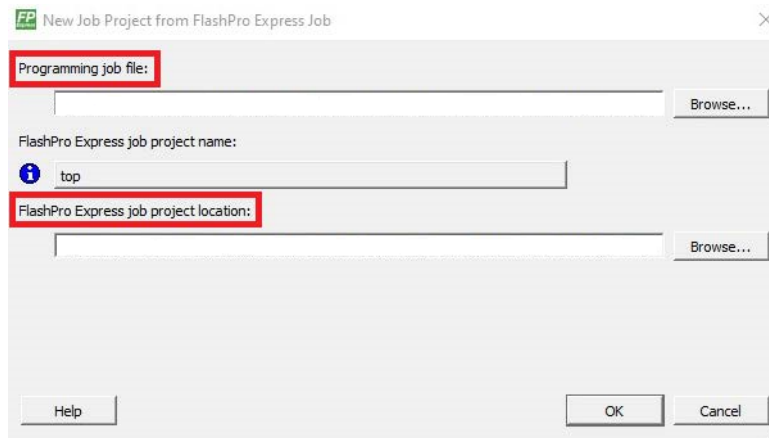
Figure 15 • New Job Project from FlashPro Express Job

7. Click **OK**. The required programming file is selected and ready to be programmed in the device.
8. The FlashPro Express window appears as shown in the following figure. Confirm that a programmer number appears in the Programmer field. If it does not, confirm the board connections and click **Refresh/Rescan Programm**ers.

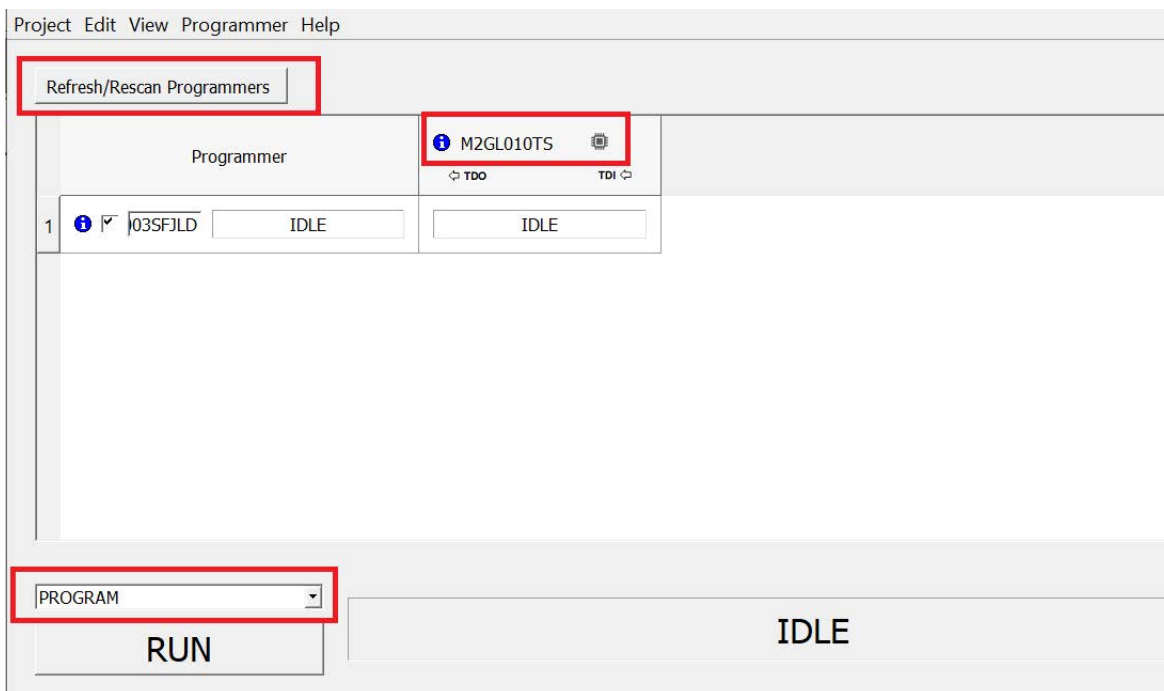
Figure 16 • Programming the Device

9. Click **RUN**. When the device is programmed successfully, a **RUN PASSED** status is displayed as shown in the following figure.

Figure 17 • FlashPro Express—RUN PASSED

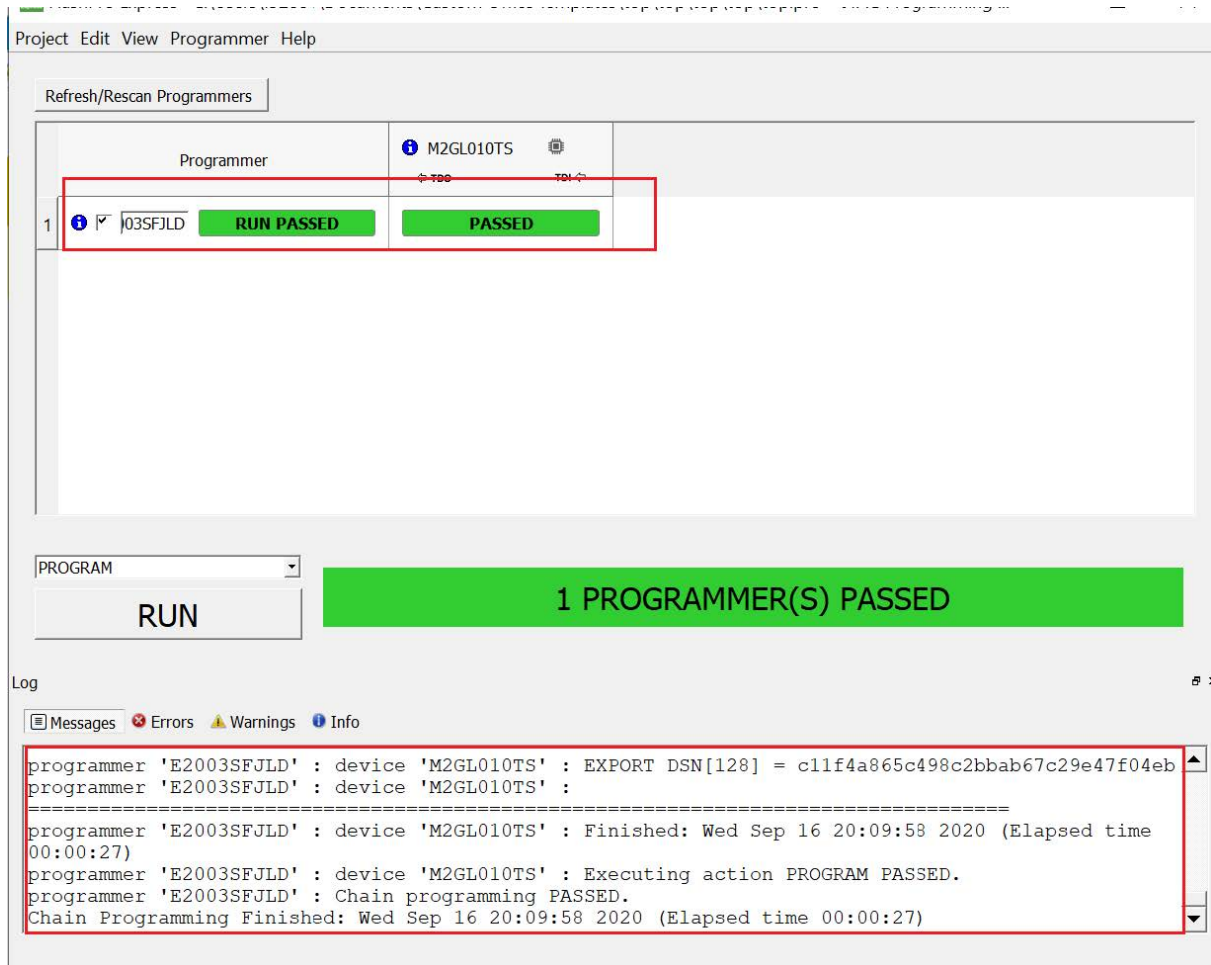

10. Close **FlashPro Express** or in the Project tab, click **Exit**.

4 Appendix 2: Running the Demo Design Using Spirent Test Center

The following steps describe how to run the CoreTSE MAC loopback demo using the Spirent test center:

1. Connect the IGLOO2 Evaluation Kit to the slot 1 Ethernet port on the Spirent test equipment using the RJ45 cable.
2. In the host PC, open the Spirent test center configurator.
3. Add **port** (Ethernet) in the Spirent test center, as shown in the following figure.

Figure 18 • Spirent Test Center Stream Block – General Tab

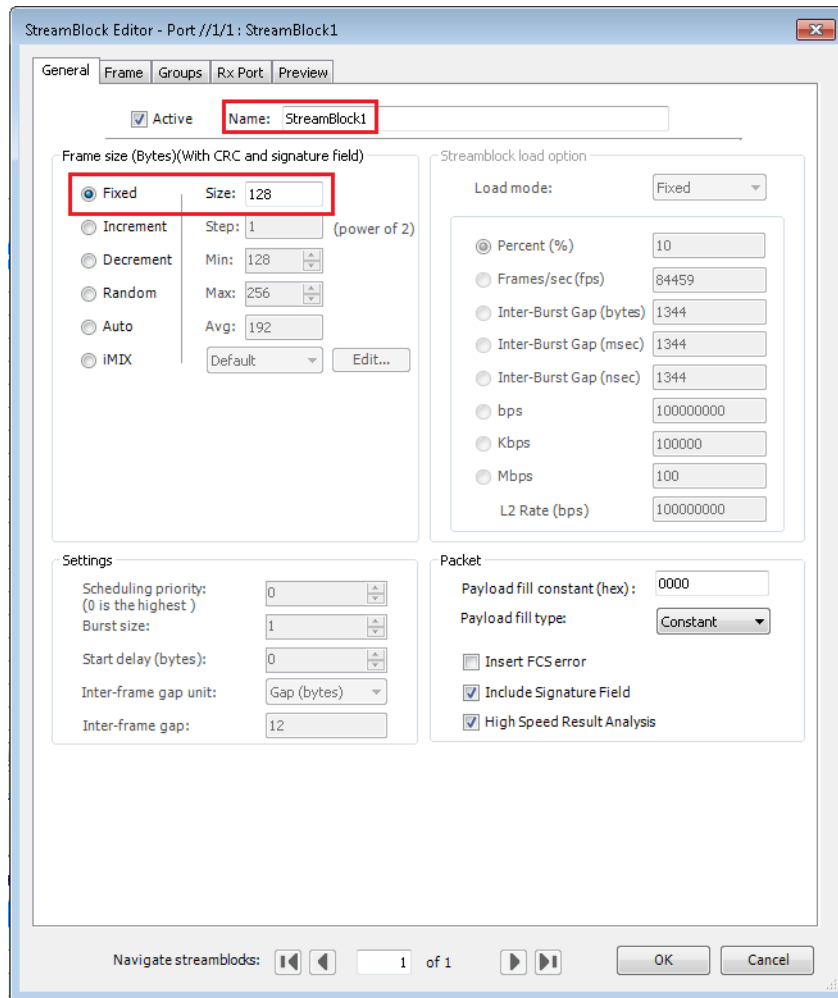

4. Click **Traffic generator** under **Port**, add packet information in the stream block editor, and click **OK** as shown in Figure 20, page 19.

Figure 19 • Spirent Test Center

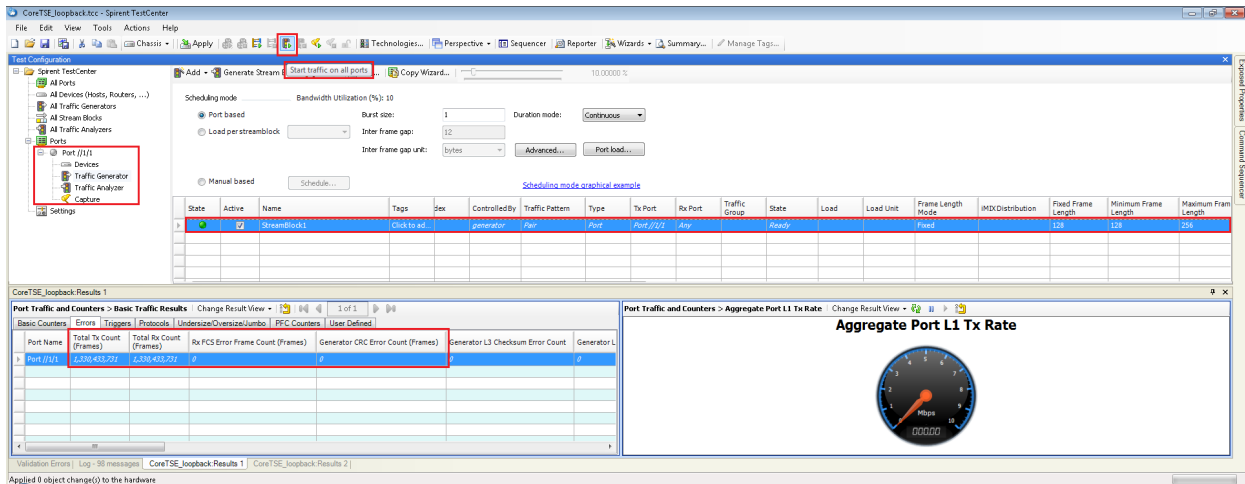

5. Click **Start traffic** on all ports, as shown in Figure 20. Ethernet packets are transmitted and received on port1 through the RJ45 cable.
6. Observe the Total TX, RX, RX FCS, and CRC error counts. Figure 20 shows the total TX, RX, RX FCS, and CRC error count information in the Spirent test center. 0 indicates no loss in the packet transmission and reception.

Figure 20 • Spirent Test Center Stream Block – Frame Tab

