



Migrating from the LAN9115 to the LAN9210

1 Objective

The purpose of this application note is to assist SMSC customers with existing LAN9115 designs when upgrading to the new LAN9210 devices. Migrating from the LAN9115 to the LAN9210 will require PCB modifications to support the new LAN9210 package type and the HP Auto-MDIX PHY (even if this mode is not used). This application note addresses all the differences between the LAN9115 and the LAN9210 devices, making this transition as easy as possible.

1.1 References

- LAN9210 Datasheet
- One-Page Reference Design for the LAN9210
- One-Page Reference Design for the LAN9115
- Application Note 8-13 Suggested Magnetics

1.2 Overview of Changes Required

Table 1.1 summarizes the changes needed to migrate from the LAN9115 to the LAN9210.

Table 1.1 Summary of Changes Required

CHANGE REQUIRED	COMMENTS	REFERENCES
New PCB	Needed to support footprint change, magnetics and passive component changes.	This application note and 1-Page Reference Designs are available at www.smSC.com .
New magnetics and passive component network on PHY side of magnetics	Needed to support HP Auto-MDIX.	See Application Note 8-13 for list of recommended magnetics, this application note and LAN9210 Datasheet are available at www.smSC.com
Firmware Upgrade	Needed to take advantage of faster Host Bus timing and mixed endian support	This application note and LAN9210 Datasheet are available at www.smSC.com .
Upgrade drivers	Recognize new device ID and utilize new Checksum Offload Engine	Refer to Table 5.1

2 Hardware Changes

2.1 Component Changes

2.1.1 Device Package

The LAN9210 is packaged in a 56-pin QFN with an exposed VSS pad. Therefore, the LAN9210 is not a drop in replacement for the LAN9115 and will require a new PCB. The recommended PCB land pattern can be found in Chapter 8 of the LAN9210 Datasheet. It is recommended to place a 4x4 grid of vias at 60mil spacing in the exposed pad area for connection to the board's ground plane, as shown in [Figure 2.1](#) below. Please consult with your Assembly House for their process capabilities and recommendations.

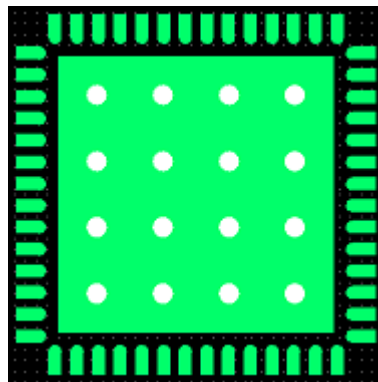

Figure 2.1 PCB Land Pattern

2.1.2 Magnetics

Migrating to the LAN9210 requires different magnetics than those used on the LAN9115. These magnetics have symmetrical channel configurations to allow for the switching of the receive and transmit channels. A list of suggested magnetics for the LAN9210 can be found in Application Note 8-13, entitled "Suggested Magnetics".

2.2 Circuit Changes

2.2.1 Transmit Circuit

The transmit circuit used by the LAN9210, as shown in [Figure 2.2](#) below, is similar to that of the LAN9115.

The similarities between the LAN9210 and the LAN9115 are as follows:

- A 49.9 ohm, 1% resistor from each side of the twisted pair to VDD_A (+3.3V)
- A 10 ohm, 1% resistor from the transmit center tap to VDD_A (+3.3V).

The differences between the LAN9210 and the LAN9115 are as follows:

- The LAN9210 uses magnetics that support HP Auto-MDIX.
- The device-side center tap of the transmit core (TCT) is attached to the device-side center-tap of the receive core (RCT).
- The 49.9 ohm resistors should be placed as close as possible to the LAN9210.

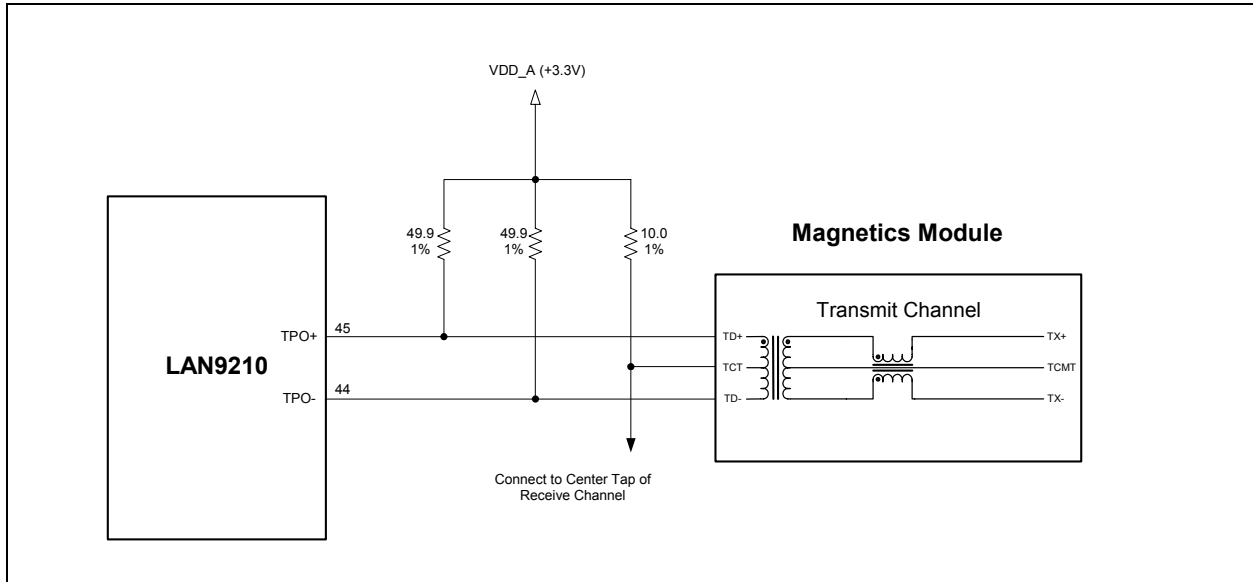

Figure 2.2 LAN9210 Transmit Circuit

2.2.2 Receive Circuit

The receive circuit used by the LAN9210, as shown in [Figure 2.3](#) below, is similar to that of the LAN9115.

The similarities between the LAN9210 and the LAN9115 are as follows:

- Both designs have two 49.9 ohm, 1% resistors between the two signals in the twisted pair.

The differences between the LAN9210 and the LAN9115 are as follows:

- The LAN9210 uses magnetics that support HP Auto-MDIX.
- The LAN9115 had two 6.8nf capacitors, one in series with each side of the twisted pair. These are eliminated (shorted) in the LAN9210.
- In the LAN9115, the mid-point between the two 49.9 ohm resistors is tied to the center tap of the magnetics (RCT) and to a 0.01uF bypass capacitor to ground. In the LAN9210, both resistors are tied to VDD_A (+3.3V), and the 0.01uF bypass capacitor has been eliminated. The center-tap of the receive channel of the magnetics is tied to the transmit center tap (TCT) and to a common 0.022uF bypass capacitor to ground.
- The 49.9 ohm resistors should be placed as close as possible to the LAN9210.

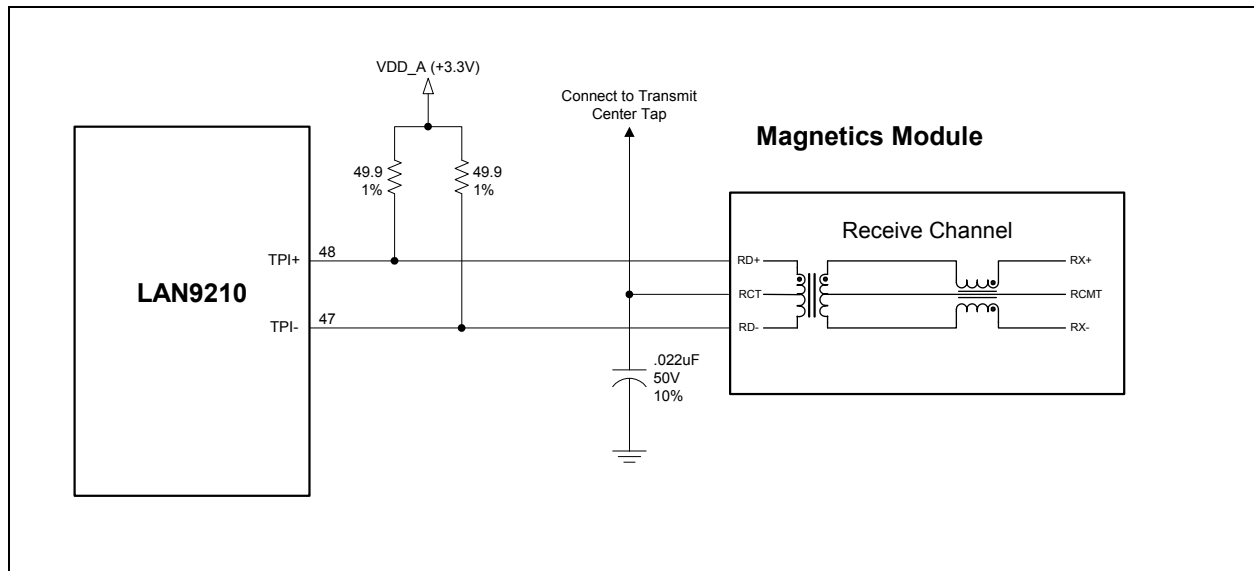

Figure 2.3 LAN9210 Receive Circuit

2.2.3 EMC Considerations

For LAN9210 designs that must operate in an EMI constrained environment, the designer should include four low valued capacitors (less than 15pF) on the TPO+, TPO-, TPI+ & TPI- pins and terminate them to digital ground. These capacitors should be placed as close as possible to the magnetics. These capacitors can then be populated as required for EMI compliance. Additionally, the use of a discrete magnetic and RJ-45 connector is highly recommended, as the integrated magnetics are known to cause EMI compliance issues.

2.3 Pin Changes

2.3.1 Pin Cross-Reference

Table 2.1 below cross-references signal/pin changes between the LAN9115 and the LAN9210.

Table 2.1 Pin Cross-Reference

LAN9115		LAN9210	
SIGNAL	PIN	SIGNAL	PIN
D[15:0]	43-46, 49-53, 56-59, 62-64	D[15:0]	19-23, 25-29, 31-36
A[7:1]	12-18	A[7:1]	6-12
nRD	92	nRD	15
nWR	93	nWR	16
nCS	94	nCS	17
IRQ	72	IRQ	43
Reserved	73, 71, 84, 90, 91	Reserved	14
		AMDIX_EN	52
SPEED_SEL	74		
FIFO_SEL	76	FIFO_SEL	13
TPO+	79	TPO+	45
TPO-	78	TPO-	44
TPI+	83	TPI+	48
TPI-	82	TPI-	47
EXRES1	87	EXRES1	50
EEDIO	67	EEDIO	38
EECS	68	EECS	39
EECLK	69	EECLK	40
XTAL1	6	XTAL1	55
XTAL2	5	XTAL2	54
nRESET	95	nRESET	42
PME	70	PME	41
GPIO[2:0]	100, 99, 98	GPIO[2:0]	5, 4, 3
RBIAS	10		
ATEST	9		
VREG	2		
VDD_IO	20, 28, 35, 42, 48, 55, 61, 97	VDD_IO	1, 18, 24, 30, 56
GND_IO	19, 27, 34, 41, 47, 54, 60, 96		
VDD_A	81, 85, 89	VDD_A33	46, 49, 51
VSS_A	77, 80, 86, 88		

Table 2.1 Pin Cross-Reference (continued)

LAN9115		LAN9210	
SIGNAL	PIN	SIGNAL	PIN
VDD_CORE	3, 65	VDD_CORE	2, 37
GND_CORE	1, 66		
VDD_PLL	7		
VSS_PLL	4		
VDD_REF	8		
VSS_REF	11		
		VDD_A18	53
		VSS	Exposed Pad
TX_CLK	40		
TXD[3:0]	36-39		
TX_EN	21		
RX_CLK	26		
RX_ER	25		
COL	33		
RXD[3:0]	24, 23, 22, 75		
CRS	32		
RX_DV	29		
MDIO	30		
MDC	31		

2.3.2 Signal Pins not Available on the LAN9210

The following signal pins are not available on the LAN9210:

- SPEED_SEL
- RBIAS
- ATEST
- TX_CLK, TXD[3:0], TX_EN
- RX_CLK, RX_ER, RXD[3:0], RX_DV
- COL, CRS
- MDIO, MDC

2.3.3 Power and Ground Pin Changes

The LAN9115 has several different ground pins (GND_IO, VSS_A, GND_CORE, VSS_PLL and VSS_REF). However, the LAN9210 uses a single ground connection (VSS) on the exposed pad. Also, the LAN9210 does not have VDD_PLL, VDD_REF, and VREG power pins.

The LAN9210 has a VDD_A18 (pin 53) that must be externally connected to VDD_CORE (pins 2, 37) with traces at least 10 mil wide and connected to a 10uF low ESR ceramic capacitor. Each of these 3 pins must be individually decoupled with a 0.01uF capacitor as close as possible to the pin, as shown in Figure 2.4, "Power Connections".

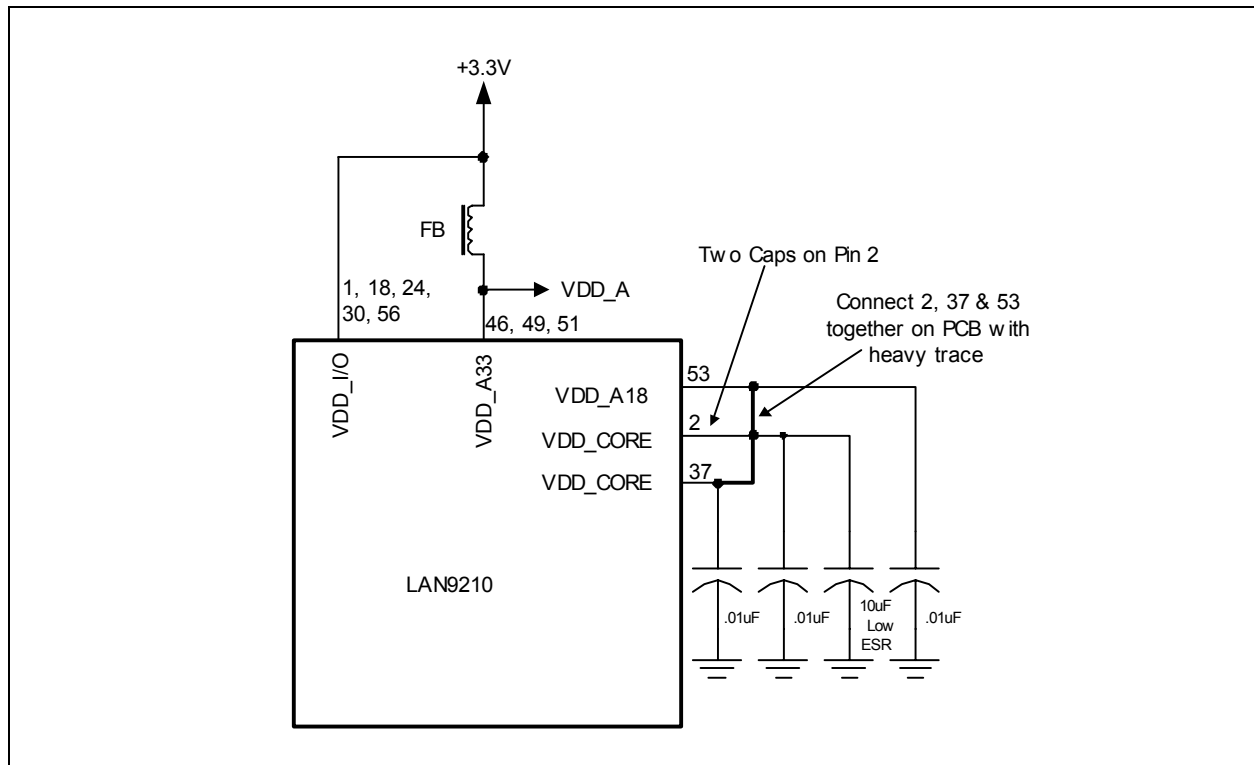

Figure 2.4 Power Connections

2.3.4 AMDIX_EN (Pin 52)

The LAN9210 includes an HP Auto-MDIX enabled PHY, this pin can be used to enable/disable Auto-MDIX on power-up/reset. This pin has an internal pull-up and must be pulled low to disable Auto-MDIX. To enable Auto-MDIX, this pin should be pulled high or left unconnected. The state of this pin can be read via the HW_CFG register and can also be overridden via Phy register 27, as described in Section 3 below.

3 Register Changes

3.1 SCSR Register Changes

3.1.1 ID_REV Register (offset: 50h)

- For the LAN9210 - Bit 31:16 changed to 9210h

3.1.2 HW_CFG Register (offset: 74h)

- Bits 6:2 become reserved
- Bit 24 becomes AMDIX_EN Strap State. This read-only bit reflects the state of the AMDIX_EN strap pin (pin 52). This pin can be overridden by PHY registers 27.15 and 27.13.
- Bit 28 becomes FSELEND, Direct FIFO Access Endian Ordering. This control bit determines the endianness of RX and TX data FIFO host accesses when accessed using the FIFO_SEL signal. When this bit is cleared, FIFO_SEL accesses utilize little endian byte ordering. When this bit is set, FIFO_SEL accesses utilize big endian byte ordering. Please refer to Section 3.8 of the LAN9210 Datasheet for more information on this feature.
- Bit 29 becomes FPORTEND, FIFO Port Endian Ordering. This control bit determines the endianness of RX and TX data FIFO host accesses when accessed through the RX/TX Data FIFO ports, including the alias addresses (any access from 00h to 3Ch). When this bit is cleared, data FIFO port accesses utilize little endian byte ordering. When this bit is set, data FIFO port accesses utilize big endian byte ordering. Please refer to Section 3.8 of the LAN9210 Datasheet for more information on this feature.

3.2 MAC Register Changes

3.2.1 COE_CR Register (offset: Dh)

The Checksum Offload Engine Control Register (COE_CR), has been added to the LAN9210 at offset Dh. This register controls the transmit and receive checksum offload engines. Please refer to Section 3.6 of the LAN9210 Datasheet for more information on this feature.

- Bits 31:17 - Reserved
- Bit 16 - TX Checksum Offload Engine Enable (TXCOE_EN). TXCOE_EN may only be changed if the TX data path is disabled. If cleared, the TXCOE is bypassed. If set, the TXCOE is enabled.
Bits 15:2 - Reserved
- Bit 1 - RX Checksum Offload Engine Mode (RXCOE_MODE). This bit indicates whether the RXCOE will check for VLAN tags or a SNAP header prior to beginning its checksum calculation. In its default mode, the calculation will always begin 14 bytes into the frame. RXCOE_MODE may only be changed if the RX data path is disabled. If set, begin checksum calculation after first 14 bytes of Ethernet Frame. If cleared, begin checksum calculation at start of L3 packet by adjusting for VLAN tags and/or SNAP header.
- Bit 0 - RX Checksum Offload Engine Enable (RXCOE_EN). RXCOE_EN may only be changed if the RX data path is disabled. If cleared, the RXCOE is bypassed. If set, the RXCOE is enabled

3.3 PHY Register Changes

3.3.1 PHY Identifier 2 (offset: 4)

The value of this register is changed from 0xC0D1 to 0xC0C3.

3.3.2 Special Control/Status Indications (offset: 27)

- Bit 15 becomes Override AMDIX Strap.
 - 0 - AMDIX_EN (pin 52) enables or disables HP Auto-MDIX.
 - 1 - Override pin 52. PHY register 27.14 and 27.13 determine MDIX function.
- Bit 14 becomes Auto-MDIX Enable. Only effective when 27.15 = 1, otherwise ignored.
 - 0 = disable Auto-MDIX, 27.13 determines normal or reversed connection.
 - 1 = enable Auto-MDIX, 27.13 must be set to 0.
- Bit 13 becomes Auto-MDIX State. Only effective when 27.15 = 1, otherwise ignored.
 - When 27.14 = 0 (manually set MDIX state):
 - 0 = no crossover (TPO = output, TPI = input).
 - 1 = crossover (TPO = input, TPI = output).
 - When 27.14 = 1 (Auto-MDIX) this bit must be set to 0.
 - Do not use the combination 27.15 = 1, 27.14 = 1, 27.13 = 1.

4 Additional Feature Changes

4.1 Mixed Endian Support

In addition to the Word Swap function supported by both the LAN9115 and the LAN9210, the LAN9210 also provides support for mixed endian data FIFO accesses. The LAN9210 provides the ability to select data FIFO endianness separately for accesses through the data FIFO ports (addresses 00h-3Ch) or using the FIFO_SEL input signal. This is accomplished via the FPORTEND and FSELEND bits of the HW_CFG—Hardware Configuration Register, respectively. Please refer to Section 3.8 of the LAN9210 Datasheet for more information.

Note: CSR and status FIFO accesses are not affected by the FPORTEND and FSELEND endianness select bits.

4.2 Checksum Offload Engine (COE)

The LAN9210 contains two checksum offload engines, which offload the calculation of the 16-bit checksum for transmitted and received Ethernet frames. Please refer to Section 3.6 of the LAN9210 Datasheet for detailed information on the use of the COE's. Please note that currently only the Linux driver supports checksum offloading.

4.2.1 Receive Checksum Offload Engine (RXCOE)

The receive checksum offload engine provides assistance to the CPU by calculating a 16-bit checksum for a received Ethernet frame. The RXCOE readily supports the following IEEE 802.3 frame formats:

- Type II Ethernet frames
- SNAP encapsulated frames
- Support for up to 2, 802.1q VLAN tags

4.2.2 Transmit Checksum Offload Engine (TXCOE)

The transmit checksum offload engine provides assistance to the CPU by calculating a 16-bit checksum, typically for TCP, for a transmit Ethernet frame. The TXCOE calculates the checksum and inserts the results back into the data stream as it is transferred to the MAC.

4.3 External PHY

The LAN9210 does not support an external PHY, therefore all signal pins associated with the external PHY on the LAN9115 are no longer available on the LAN9210. These include:

- TX_CLK, TXD[3:0], TX_EN
- RX_CLK, RX_ER, RXD[3:0], RX_DV
- COL, CRS
- MDIO, MDC

Note: TX_CLK, TX_EN, RX_CLK and RX_DV can still be observed the GPO3 and GPO4 pins.

5 Driver Support

Table 5.1 below shows the version of drivers needed to support the LAN9210.

Table 5.1 Driver Support

DRIVER	REVISION
WinCE 5.0 - XScale (PXA270)	1.10 or later
Linux - XScale (PXA270)	1.52 or later



80 ARKAY DRIVE, HAUPPAUGE, NY 11788 (631) 435-6000, FAX (631) 273-3123

Copyright © 2008 SMSC or its subsidiaries. All rights reserved.

Circuit diagrams and other information relating to SMSC products are included as a means of illustrating typical applications. Consequently, complete information sufficient for construction purposes is not necessarily given. Although the information has been checked and is believed to be accurate, no responsibility is assumed for inaccuracies. SMSC reserves the right to make changes to specifications and product descriptions at any time without notice. Contact your local SMSC sales office to obtain the latest specifications before placing your product order. The provision of this information does not convey to the purchaser of the described semiconductor devices any licenses under any patent rights or other intellectual property rights of SMSC or others. All sales are expressly conditional on your agreement to the terms and conditions of the most recently dated version of SMSC's standard Terms of Sale Agreement dated before the date of your order (the "Terms of Sale Agreement"). The product may contain design defects or errors known as anomalies which may cause the product's functions to deviate from published specifications. Anomaly sheets are available upon request. SMSC products are not designed, intended, authorized or warranted for use in any life support or other application where product failure could cause or contribute to personal injury or severe property damage. Any and all such uses without prior written approval of an Officer of SMSC and further testing and/or modification will be fully at the risk of the customer. Copies of this document or other SMSC literature, as well as the Terms of Sale Agreement, may be obtained by visiting SMSC's website at <http://www.smisc.com>. SMSC is a registered trademark of Standard Microsystems Corporation ("SMSC"). Product names and company names are the trademarks of their respective holders.

SMSC DISCLAIMS AND EXCLUDES ANY AND ALL WARRANTIES, INCLUDING WITHOUT LIMITATION ANY AND ALL IMPLIED WARRANTIES OF MERCHANTABILITY, FITNESS FOR A PARTICULAR PURPOSE, TITLE, AND AGAINST INFRINGEMENT AND THE LIKE, AND ANY AND ALL WARRANTIES ARISING FROM ANY COURSE OF DEALING OR USAGE OF TRADE. IN NO EVENT SHALL SMSC BE LIABLE FOR ANY DIRECT, INCIDENTAL, INDIRECT, SPECIAL, PUNITIVE, OR CONSEQUENTIAL DAMAGES; OR FOR LOST DATA, PROFITS, SAVINGS OR REVENUES OF ANY KIND; REGARDLESS OF THE FORM OF ACTION, WHETHER BASED ON CONTRACT; TORT; NEGLIGENCE OF SMSC OR OTHERS; STRICT LIABILITY; BREACH OF WARRANTY; OR OTHERWISE; WHETHER OR NOT ANY REMEDY OF BUYER IS HELD TO HAVE FAILED OF ITS ESSENTIAL PURPOSE, AND WHETHER OR NOT SMSC HAS BEEN ADVISED OF THE POSSIBILITY OF SUCH DAMAGES.